

Safety Instructions

Proservo NMS80/NMS81/NMS83

JPN: Ex db [ia Ga] IIC T6...T1 Ga/Gb



Proservo NMS80/NMS81/NMS83

Table of contents

Associated documentation	4
Supplementary documentation	4
Manufacturer's certificates	4
Manufacturer address	4
Extended order code	4
Safety instructions: General	7
Safety instructions: Special conditions	7
Safety instructions: Installation	8
Safety instructions: Zone 0	11
Connection data	12

Associated documentation	<p>This document is an integral part of the following Operating Instructions:</p> <ul style="list-style-type: none"> ■ BA01456G (NMS80) ■ BA01459G (NMS81) ■ BA01462G (NMS83) 										
Supplementary documentation	<p>Explosion-protection brochure: CP00021Z/11</p> <p>The Explosion-protection brochure is available:</p> <ul style="list-style-type: none"> ■ In the download area of the Endress+Hauser website: www.endress.com -> Downloads -> Media Type: Documentation -> Documentation Type: Brochures and catalogs -> Text Search: CP00021Z ■ On the CD for devices with CD-based documentation 										
Manufacturer's certificates	<p>Certificates of approval</p> <p>Approval no.: CML 20JPN1246X</p> <p>Affixing the approval number certifies conformity with the following standards (depending on the device version):</p> <ul style="list-style-type: none"> ■ JNIO SH-TR-46-1 : 2015 ■ JNIO SH-TR-46-2 : 2018 ■ JNIO SH-TR-46-6 : 2015 ■ IEC 60079-26 : 2014 										
Manufacturer address	<p>Endress+Hauser Yamanashi Co., Ltd. 406-0846 862-1 Mitsukunugi, Sakaigawa-cho, Fuefuki-shi, Yamanashi</p>										
Extended order code	<p>The extended order code is indicated on the nameplate, which is affixed to the device in such a way that it is clearly visible. Additional information about the nameplate is provided in the associated Operating Instructions.</p> <p>Structure of the extended order code</p> <table border="0" style="margin-left: 40px;"> <tr> <td style="text-align: center;">NMS8x</td> <td style="text-align: center;">-</td> <td style="text-align: center;">*****</td> <td style="text-align: center;">+</td> <td style="text-align: center;">A*B*C*D*E*F*G*..</td> </tr> <tr> <td style="text-align: center;"><i>(Device type)</i></td> <td></td> <td style="text-align: center;"><i>(Basic specifications)</i></td> <td></td> <td style="text-align: center;"><i>(Optional specifications)</i></td> </tr> </table> <p>* = Placeholder At this position, an option (number or letter) selected from the specification is displayed instead of the placeholders.</p> <p><i>Basic specifications</i></p> <p>The features that are absolutely essential for the device (mandatory features) are specified in the basic specifications. The number of positions depends on the number of features available. The selected option of a feature can consist of several positions.</p> <p><i>Optional specifications</i></p> <p>The optional specifications describe additional features for the device (optional features). The number of positions depends on the number of features available. The features have a 2-digit structure to aid identification (e.g. JA). The first digit (ID) stands for the feature group and consists of a number or a letter (e.g. J = Test, Certificate). The second digit constitutes the value that stands for the feature within the group (e.g. A = 3.1 material (wetted parts), inspection certificate).</p>	NMS8x	-	*****	+	A*B*C*D*E*F*G*..	<i>(Device type)</i>		<i>(Basic specifications)</i>		<i>(Optional specifications)</i>
NMS8x	-	*****	+	A*B*C*D*E*F*G*..							
<i>(Device type)</i>		<i>(Basic specifications)</i>		<i>(Optional specifications)</i>							

More detailed information about the device is provided in the following tables. These tables describe the individual positions and IDs in the extended order code which are relevant to hazardous locations.

Extended order code: Proservo

-  The following specifications reproduce an extract from the product structure and are used to assign:
- This documentation to the device (using the extended order code on the nameplate).
 - The device options cited in the document.

Device type

NMS80/NMS81/NMS83

Basic specifications

Position 1, 2 (Approval)		
Selected option		Description
NMS8x	JC	JPN Ex db [ia Ga] IIC T6...T1 Ga/Gb

Position 4 (Power supply, display)		
Selected option		Description
NMS8x	B	AC85-264V; LCD + Operation
	D	AC52-75V; LCD + Operation
	E	DC19-64V; LCD + Operation

Position 5, 6 (Primary output)		
Selected option		Description
NMS8x	A1	Modbus RS485
	B1	V1
	C1	WM550
	E1	4-20 mA HART Ex d/XP
	H1	4-20 mA HART Ex i/IS

Position 7, 8 (Secondary I/O, analog)		
Selected option		Description
NMS8x	A1	Ex d/XP, 1x 4-20 mA HART, 1x RTD input
	A2	Ex d/XP, 2x 4-20 mA HART, 2x RTD input
	B1	Ex i/IS, 1x 4-20 mA HART, 1x RTD input
	B2	Ex i/IS, 2x 4-20 mA HART, 2x RTD input
	C2	1x Ex i/IS 4-20 mA HART, 2x RTD input + 1x Ex d/XP 4-20 mA HART
	X0	Not selected

Position 9, 10 (Secondary I/O, digital Ex d)		
Selected option		Description
NMS8x	A1	2x relay + 2x module contacts (discrete)
	A2	4x relay + 4x module contacts (discrete)
	A3	6x relay + 6x module contacts (discrete)
	B1	Modbus RS485
	B2	Modbus RS485 + 2x relay + 2x module contacts (discrete)
	B3	Modbus RS485 + 4x relay + 4x module contacts (discrete)
	E1	WM550
	E2	WM550 + 2x relay / 2x module contacts (discrete)
	E3	WM550 + 4x relay / 4x module contacts (discrete)
	X0	Not selected

Position 11, 12 (Housing)		
Selected option		Description
NMS80	AB	Transmitter + Process Alu coated
NMS81	AC	Transmitter Alu coated + Process SUS316/316L equivalent
	AD	Transmitter Alu coated + Process SUS316/316L equivalent internal FEP coated
	BC	Transmitter + Process SUS 316/316L equivalent
	BD	Transmitter SUS316/316L equivalent + Process SUS316/316L equivalent internal FEP coated
NMS83	AC	Transmitter Alu coated + Process SUS316/316L equivalent
	BC	Transmitter + Process SUS 316/316L equivalent

Position 13 (Process pressure)		
Selected option		Description
NMS80	1	0-0.2 bar / 20 kPa / 2.9 psi
	2	0-6 bar / 600 kPa / 87 psi
NMS81	1	0-0.2 bar / 20 kPa / 2.9 psi
	2	0-6 bar / 600 kPa / 87 psi
	3	0-25 bar / 2.5 MPa / 362 psi
NMS83	2	0-6 bar / 600 kPa / 87 psi

Position 20, 21 (Process sealing)		
Selected option		Description
NMS8x	A1	HNBR -30 to +150 °C (-22 to +320 °F)
	B1	FKM GLT, -40 to 200 °C (-40 to +392 °F)
	C1	CR chloroprene -25 to +100 °C (-13 to 212 °F)
	D1	PTFE (wire drum FKM) -100 to +200 °C (-148 to +392 °F)
	E1	VMQ silicon -45 to +200 (-49 to +392)

Optional specifications

Accessory mounted		
Selected option		Description
NMS8x	PA	Sunshade cover
	RA	Relief valve Rc3/8
	RB	Gas purge nozzle connection Rc3/8
	RC	Pressure gauge Rc3/8
	RD	Cleaning nozzle connection Rc3/8
	RG	Guide wire assembly

Safety instructions: General

- Staff must meet the following conditions for mounting, electrical installation, commissioning and maintenance of the device:
 - Be suitably qualified for their role and the tasks they perform
 - Be trained in explosion protection
 - Be familiar with national regulations
- Install the device according to the manufacturer's instructions and national regulations.
- Do not operate the device outside the specified electrical, thermal and mechanical parameters.
- Only use the device in media to which the wetted materials have sufficient durability.
- Avoid electrostatic charging of the following:
 - Plastic surfaces (e.g., housings, sensor elements, special varnishing, attached additional plates, etc.)
 - Isolated capacities (e.g., isolated metallic plates)
- Refer to the temperature tables for the relationship between the permitted ambient temperature for the sensor and/or transmitter, depending on the range of application and the temperature class.
- Modifications to the device can affect the explosion protection and must be carried out by staff authorized to perform such work by Endress+Hauser.
- For information on Ex d joint dimensions, follow the Operating Instructions and contact us.

Safety instructions: Special conditions

Ambient temperature range: $-40\text{ °C } (-40\text{ °F}) \leq T_a \leq +50\text{ °C } (122\text{ °F})$, $+55\text{ °C } (131\text{ °F})$, or $+60\text{ °C } (+140\text{ °F})$

For each condition, check the temperature table.

- In the event of additional or alternative special varnishing on the housing or other metal parts:
 - Observe the danger of electrostatic charging and discharge.
 - Do not rub surfaces with a dry cloth.
- Flame path joints cannot be repaired. If any scratches, cracks, deformations, etc. are found on a joint due to maintenance service, etc., stop using the product and contact Endress + Hauser.
- Use heat resisting cables rated $\geq 85\text{ °C}$ for $T_a > 50\text{ °C}$.
- To maintain the ingress protection ratings (IP66/68), teflon tape or pipe dope is required for blanking plugs.
- Ex d certified seals are required within 50 mm (2 in) on all used housing entries.

**Safety instructions:
Installation**

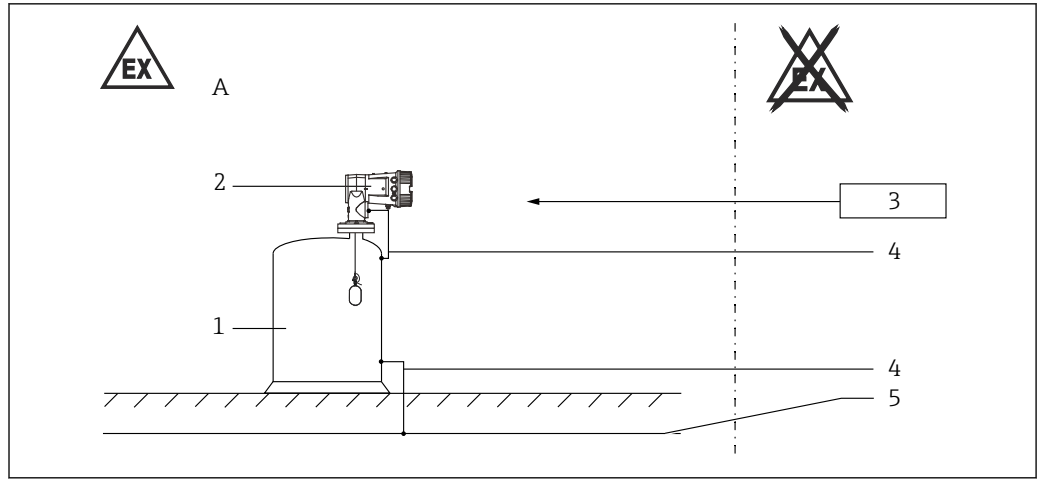

1

- A Zone 1, Zone 2
- 1 Tank; Zone 0, Zone 1
- 2 Connections and electronic circuits Ex d (Proservo NMS8x)
- 3 Power supply
- 4 Ground wire
- 5 Potential equalization line

- Install the device to exclude any mechanical damage or friction during the application. Pay particular attention to flow conditions and tank fittings.
- Pay particular attention to the following points to prevent leakage of gas or steam into the tank:
 - Connections between equipment and tank connection flanges
 - When opening and reclosing the drum chamber lid during maintenance service, etc., replace the ring if it has any deterioration or deformation.
- In potentially explosive atmospheres:
 - Do not disconnect the electrical connection of the power supply circuit when energized.
 - Do not open the connection compartment cover.
- Only use certified cable entries suitable for the application. Observe national regulations and standards. Accordingly, the connection terminal does not include any ignition sources.
- When operating the transmitter housing at an ambient temperature under $-20\text{ }^{\circ}\text{C}$, use appropriate cables and cable entries permitted for this application.
- Seal unused entry glands with approved sealing plugs that correspond to the type of protection. The plastic transport sealing plug does not meet this requirement and must therefore be replaced during installation.
- Before operation:
 - Screw in the cover all the way.
 - Tighten the securing clamp on the cover.
- Install MS80/81/83 so that the displacer does not sway or rotate during operation and the displacer does not come into contact with the tank wall. For the aluminum drum housing (NMS80), impact and friction on the equipment should be avoided to prevent the risk of firing the drum housing and internal components.

The drum chamber (Zone 0) and the electrical chamber (Zone 1) isolation walls meet the requirements of IEC 60079-26, 4.2.5.3 i). The drum chamber maximum system pressure is shown in the table below.

Isolation of special hazardous area (Zone 0) and Class 1 hazardous area (Zone 1)

Device type	Selected option Position 13 (Process pressure)	Maximum system pressure (MWP)
NMS80	1	0.02 MPa (0.2 bar)
	2	0.6 MPa (6 bar)
NMS81	1	0.02 MPa (0.2 bar)
	2	0.6 MPa (6 bar)

Device type	Selected option Position 13 (Process pressure)	Maximum system pressure (MWP)
	3	2.5 MPa (25 bar)
NMS83	2	0.6 MPa (6 bar)

Potential equalization

Integrate the device into the local potential equalization.

Withstand voltage test result

The insulation between intrinsically safe circuit and vessel conforms to the withstand voltage test (voltage AC 500 Vrms and leakage current 5 mA).

Overvoltage protection

Overvoltage protection against atmospheric overvoltages.

The following Terminal outputs / configurations need no separate external overvoltage protection measures:

Number	Terminal
Power supply	G
HART interface	E
External display	F

- Device configuration:
 - Basic specification, Position 5, 6 (Primary output) = A1, B1, C1, E1, F1, H1
 - Basic specification, Position 7, 8 (Secondary I/O, analog) = A1, A2, B1, B2, C2, X0
 - Basic specification, Position 9, 10 (Secondary I/O, digital Ex d) = B1, C1, E1
- All other configurations must be protected by separate additional measures to comply national regulations and standards.
- Observe the safety instructions of the overvoltage protection.

Ingress protection of vessels

Based on the requirements of JNIOHSH-TR-46-6: 2015, verification is being carried out for IP20. (Other than the above, all P66/68, NEMA Type 4x/6P tests have been passed.)

Temperature table

Temperature class	Ambient temperature	Process temperature
T1	-40 °C (-40 °F) ≤ Ta ≤ +60 °C (+140 °F)	-253 (-423.4) ≤ Tpro ≤ 450 °C (842 °F)
T2	-40 °C (-40 °F) ≤ Ta ≤ +55 (131)	-253 (-423.4) ≤ Tpro ≤ 300 °C (572 °F)
T3	-40 °C (-40 °F) ≤ Ta ≤ +50 (122)	-253 (-423.4) ≤ Tpro ≤ 200 °C (392 °F)
T4	(See the following table)	-253 (-423.4) ≤ Tpro ≤ 135 °C (275 °F)
T5		-253 (-423.4) ≤ Tpro ≤ 100 °C (212 °F)
T6		-253 (-423.4) ≤ Tpro ≤ 85 °C (185 °F)

The ambient temperature range depends on the combination of vessels and mounting boards.

Table 1: Position 11, 12 (Housing) = AB

Ambient temperature range
-40 °C (-40 °F) ≤ Ta ≤ +60 °C (+140 °F)

Table 2: Position 11, 12 (Housing) = AC, AD

	Slots A / B / C / D					Ambient temperature range Ta
	IOM V1/WM	IOM Mod/FF	IOM_A [Ex d]	IOM_A [Ex i]	IOM_D	
1				1	3	-40 °C ≤ Ta ≤ 55 °C
2			1		3	
For board combinations other than the above						-40 °C ≤ Ta ≤ 60 °C

Table 3: Position 11, 12 (Housing) = BC, BD

	Slots A / B / C / D					Ambient temperature range Ta
	IOM V1/WM	IOM Mod/FF	IOM_A [Ex d]	IOM_A [Ex i]	IOM_D	
1	1				3	-40 °C (-40 °F) ≤ Ta ≤ +50 °C (+122 °F)
2	1		1		2	
3	1			1	2	
4	1			2	1	
5	1		1	1	1	
6	1		2		1	
7		1			3	
8			2		2	
9			1	1	2	
10				2	2	
11				1	3	
12			1		3	
13	1		1		1	-40 °C (-40 °F) ≤ Ta ≤ +55 °C (+131 °F)
14	1			1	1	
15	1				2	
16		1	2		1	
17		1	1	1	1	
18		1		1	1	
19		1	1		1	
20		1		2	1	
21		1	1		2	
22		1		1	2	
23		1			2	
24			2		1	
25			1	1	1	
26				2	1	
27			1		2	
28				1	2	
For board combinations other than the above						-40 °C (-40 °F) ≤ Ta ≤ +60 °C (+140 °F)

Installation in low temperature or high temperature liquid tanks

- The ambient temperature of the electrical chamber should not exceed the specified ambient temperature range due to the impact of the measured liquid temperature.
- When installing in a high temperature or low temperature storage tank, prevent high temperature or low temperature air or steam from the liquid from transferring through the tank wall directly to the NMS8x.
- To prevent high temperature or low temperature air from the liquid from transferring directly to the NMS8x, take the following measures:
 - Cover the tank with thermal isolation material.
 - Insert an ambient temperature control pipe between the NMS8x and the tank nozzle.

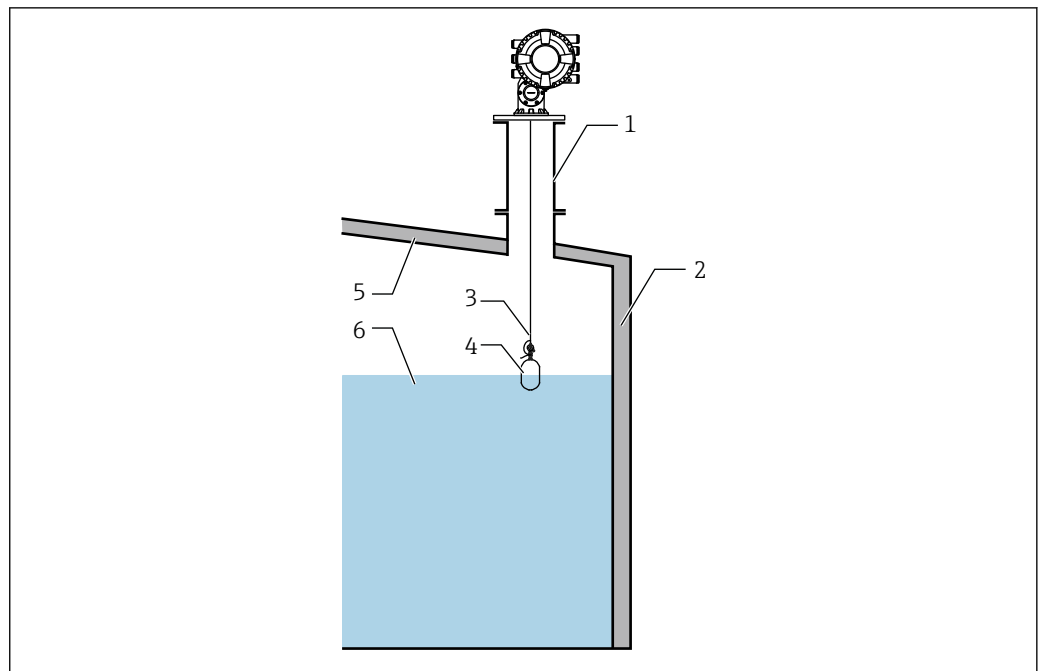

A0039927

- 1 Ambient temperature control pipe (optional)
- 2 Thermal isolation material
- 3 Measuring wire
- 4 Displacer
- 5 Tank wall
- 6 High or low temperature liquid



Flange and drum chamber temperature: $-40\text{ °C} \leq T_a \leq +50, +55, \text{ or } +60\text{ °C}$

Safety instructions: Zone 0

- In the event of potentially explosive vapor/air mixtures, only operate the device under atmospheric conditions.
 - Temperature: -20 to $+60\text{ °C}$
 - Pressure: 80 to 110 kPa (0.8 to 1.1 bar)
 - Air with normal oxygen content, usually 21 % (V/V)
- If no potentially explosive mixtures are present, or if additional protective measures have been taken, the device may also be operated under non-atmospheric conditions in accordance with the manufacturer's specifications.

Connection data

Connection compartment Ex d

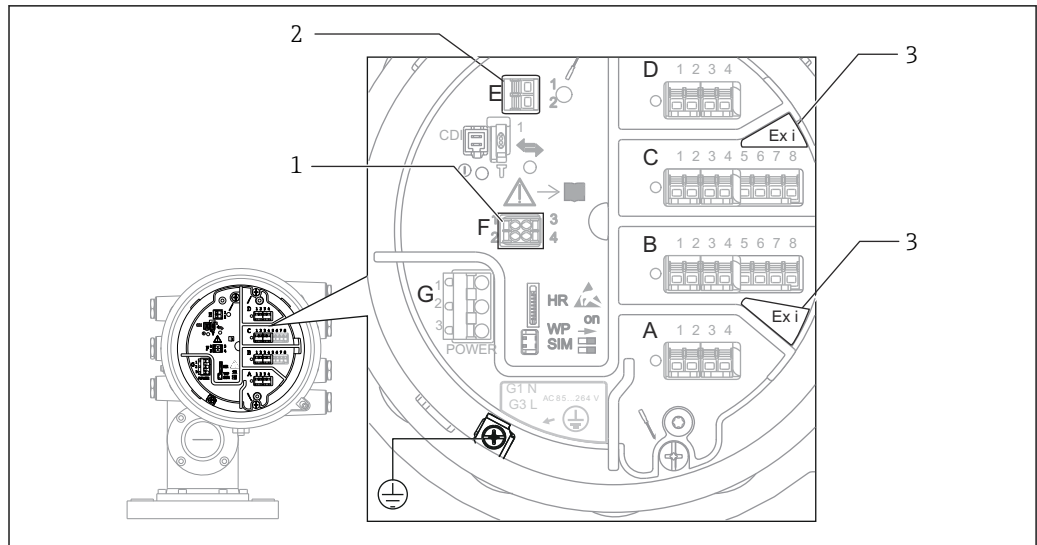

A0039928

2

- 1 External display connection (Ex i)
- 2 HART interface connection (Ex i)
- 3 Display only when "Analog (Ex i)" is implemented

Detailed configuration information is located on the display holder.

Example for lettering:

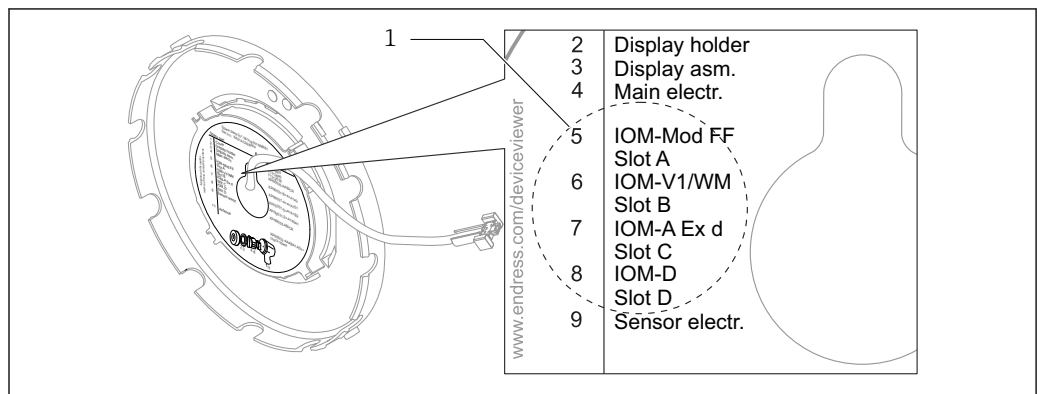

A0032011

3

- 1 Implemented modules and slots

i For detailed information see Operating Instructions.

i For the assignment of each terminal, see the designation on the front.

TRC[01], type "Power supply"

Terminal	G	CDI
	Power supply: 85 to 264 V _{AC} 52 to 75 V _{AC} G1: N G2: not connected G3: L Power supply: 19 to 64 V _{DC} G1: L- G2: not connected G3: L+	Plug connected
Name	Power supply	Local LCD, CDI (internal)
non-Ex (functional)	Power supply: 85 to 264 V _{AC} U _N = 85 to 264 V _{AC} , 50/60 Hz P _N = 28.8 VA 52 to 75 V _{AC} U _N = 52 to 75 V _{AC} , 50/60 Hz P _N = 21.6 VA Power supply: 19 to 64 V _{DC} U _N = 19 to 64 V _{DC} P _N = 13.4 W	U _N = 3.3 V _{DC} P _N = 41 mW

TRC[10], type "Main board"

Terminal	E	F
	E1: H+ E2: H-	F1: Vcc F2: A F3: B F4: gnd
Name	4-20 mA HART	Remote display
Ex [ia]	U _o = 29 V I _o = 110 mA P _o = 700 mW C _o = 65 nF L _o = 2.9 mH	U _o = 3.9 V I _o = 500 mA P _o = 230 mW C _o = 99 µF L _o = 140 µH
non-Ex (functional)	U _N = 24 V _{DC} P _N ≤ 426 mW	U _N = 3.3 V _{DC} P _N = 41 mW

TRC[32], type "Modbus" module; optional

Terminal	Slot A through slot D	
	1: S cable shield; capacitive ground connection 2: 0V common 3: B- non-inverting signal 4: A+ inverting signal	
Name	Modbus slave	FOUNDATION fieldbus
non-Ex (functional)	U _N = 12 V _{DC} P _N ≤ 12 mW U _M = 250 V	Currently not supported

TRC [33], type "V1 / WM550" module; optional

Terminal	Slot A through slot D	
	1: S cable shield; capacitive ground connection 2: No connection 3: B- signal - 4: A+ signal +	
Name	V1 slave	WM550
non-Ex (functional)	$U_N = 24 V_{DC}$ $P_N \leq 414 mW$ $U_M = 250 V$	$U_N = 3.8 V_{DC}$ $P_N \leq 114 mW$ $U_M = 250 V$

TRC[20], type "Analog module" (Ex i); 4-20 mA HART; optional

Terminal	Slot B or slot C	
Operation mode: <ul style="list-style-type: none"> ■ 4 to 20 mA output or HART slave + 4 to 20 mA output or ■ 4 to 20 mA input or HART master + 4 to 20 mA input or ■ HART master 	4-wire RTD connection: Terminals 5 through 8	Terminal active use: Terminal 2: H- 3: H+
	3-wire RTD connection: Terminals 5, 6, and 8	Terminal passive use: 1: H- 2: H+
	2-wire RTD connection: Terminals 5 and 8	
Name	24 V + RTD	4-20 mA HART
Ex [ia]	Terminals 4-5 (24 V): $U_o = 29 V$ $I_o = 108 mA$ $P_o = 776 mW$ $C_o = 63 nF$ $L_o = 3.0 mH$	Terminals 2-3 (active): $U_o = 29 V$ $I_o = 106 mA$ $P_o = 760 mW$ $C_o = 63 nF$ $L_o = 3.1 mH$
	Terminals 5-8 (RTD): $U_o = 29 V$ $I_o = 36 mA$ $P_o = 263 mW$ $C_o = 64 nF$ $L_o = 26 mH$	Terminals 1-2 (passive): $U_i = 29 V$ $I_i = 106 mA$ $P_i = 760 mW$ $C_i = 11 nF$ $L_i = 0$
non-Ex (functional)	Terminals 4-5 (24 V): $U_N = 24 V_{DC}$ $P_N \leq 600 mW$	Terminals 2-3 (active): $U_N = 24 V_{DC}$ $P_N \leq 540 mW$
	Terminals 5-8 (RTD): $I_N = 400 \mu A_{DC}$ $P_N \leq 160 \mu W$	Terminals 1-2 (passive): $U_N = 29 V_{DC}$ $P_N \leq 653 mW$

TRC[21], type "Analog module" (Ex d); 4-20 mA HART; optional

Terminal	Slot B or slot C	
Operation mode: <ul style="list-style-type: none"> ▪ 4 to 20 mA output or HART slave + 4 to 20 mA output or ▪ 4 to 20 mA input or HART master + 4 to 20 mA input or ▪ HART master 	4-wire RTD connection: Terminals 5 through 8 3-wire RTD connection: Terminals 5, 6, and 8 2-wire RTD connection: Terminals 5 and 8	Terminal active use: 2: H- 3: H+ Terminal passive use: 1: H- 2: H+
	Name 24 V + RTD	4-20 mA HART
non-Ex (functional)	Terminals 4-5 (24 V): Not used	Terminals 2-3 (active): $U_N = 24 V_{DC}$ $P_N \leq 540 mW$ $U_M = 250 V$
	Terminals 5-8 (RTD): $I_N = 400 \mu A_{DC}$ $P_N \leq 160 \mu W$ $U_M = 250 V$	Terminals 1-2 (passive): $U_N = 29 V_{DC}$ $P_N \leq 653 mW$ $U_M = 250 V$

TRC[31], type "Digital"; optional

Terminal	Slot A through slot D	
Operation mode: <ul style="list-style-type: none"> ▪ Not enabled ▪ Passive output ▪ Passive input ▪ Active input 	Installed in slot A: 1: A1-1 3: A2-1 2: A1-2 4: A2-2	
	Installed in slot B: 1: B1-1 3: B2-1 2: B1-2 4: B2-2	
	Installed in slot C: 1: C1-1 3: C2-1 2: C1-2 4: C2-2	
	Installed in slot D: 1: D1-1 3: D2-1 2: D1-2 4: D2-2	
Name	Relay / digital input / output 1	Relay / digital input / output 2
non-Ex (functional)	Relay: $U_N = 250 V_{AC/DC}$ $I_N \leq 2 A$	Relay: $U_N = 250 V_{AC/DC}$ $I_N \leq 2 A$
	Digital input: $U_N = 5 \text{ to } 230 V_{AC/DC}$ $U_M = 250 V$	Digital input: $U_N = 5 \text{ to } 230 V_{AC/DC}$ $U_M = 250 V$



www.addresses.endress.com
