

# Safety Instructions

## Liquiphant M, Liquiphant S FTL50(H), FTL51(H), FTL51C, FTL70/71

Ex d IIC T2...T6 Ga/Gb

Ex d IIC/IIIB T3...T6 Ga/Gb





# Liquiphant M, Liquiphant S FTL50(H), FTL51(H), FTL51C, FTL70/71

## Table of contents

About this document .....	4
Associated documentation .....	4
Supplementary documentation .....	4
Manufacturer's certificates .....	4
Manufacturer address .....	4
Extended order code .....	5
Safety instructions: General .....	10
Safety instructions: Special conditions .....	11
Safety instructions: Installation .....	11
Safety instructions: Ex d joints .....	12
Safety instructions: Zone 0 .....	13
Explosion protection with heat insulation .....	13
Temperature tables .....	14
Connection data .....	17

**About this document**

This document has been translated into several languages. Legally determined is solely the English source text.

**Associated documentation**

This document is an integral part of the following Operating Instructions:

- KA00143F/00, KA00163F/00 (FTL50, FTL51)
- KA00144F/00, KA00164F/00 (FTL50H, FTL51H)
- KA00162F/00, KA00165F/00 (FTL51C)
- KA00172F/00, KA00173F/00 (FTL70, FTL71)

**Supplementary documentation**

Explosion-protection brochure: CP00021Z/11

The Explosion-protection brochure is available:

- In the download area of the Endress+Hauser website:  
[www.endress.com](http://www.endress.com) -> Downloads -> Brochures and Catalogs -> Text Search: CP00021Z
- On the CD for devices with CD-based documentation

**Manufacturer's certificates****NEPSI Declaration of Conformity**

*Device type FTL50, FTL50H, FTL51, FTL51H, FTL51C*

Certificate number:

GYJ21.3315X

*Device type FTL70, FTL71*

Certificate number:

GYJ21.3316X

Affixing the certificate number certifies conformity with the following standards (depending on the device version):

- GB 3836.1-2010
- GB 3836.2-2010
- GB 3836.3-2010
- GB 3836.20-2010

**Manufacturer address**

Endress+Hauser SE+Co. KG

Hauptstraße 1

79689 Maulburg, Germany

Address of the manufacturing plant: See nameplate.

**Extended order code**

The extended order code is indicated on the nameplate, which is affixed to the device in such a way that it is clearly visible. Additional information about the nameplate is provided in the associated Operating Instructions.

**Structure of the extended order code**

FTL5x(x), FTL7x	-	*****	+	A*B*C*D*E*F*G*..
<i>(Device type)</i>		<i>(Basic specifications)</i>		<i>(Optional specifications)</i>

\* = Placeholder

At this position, an option (number or letter) selected from the specification is displayed instead of the placeholders.

*Basic specifications*

The features that are absolutely essential for the device (mandatory features) are specified in the basic specifications. The number of positions depends on the number of features available.

The selected option of a feature can consist of several positions.

*Optional specifications*

The optional specifications describe additional features for the device (optional features). The number of positions depends on the number of features available. The features have a 2-digit structure to aid identification (e.g. JA). The first digit (ID) stands for the feature group and consists of a number or a letter (e.g. J = Test, Certificate). The second digit constitutes the value that stands for the feature within the group (e.g. A = 3.1 material (wetted parts), inspection certificate).

More detailed information about the device is provided in the following tables. These tables describe the individual positions and IDs in the extended order code which are relevant to hazardous locations.

**Extended order code: Liquiphant M**

The following specifications reproduce an extract from the product structure and are used to assign:

- This documentation to the device (using the extended order code on the nameplate).
- The device options cited in the document.

*Device type*

FTL50, FTL50H, FTL51, FTL51H, FTL51C

*Basic specifications*

Position 1 (Approval)		
Selected option	Description	
FTL50(H) FTL51(H)	N	NEPSI Ex d IIC T3...T6 Ga/Gb
FTL51C	N <sup>1)</sup>	NEPSI Ex d IIC T3...T6 Ga/Gb
	N <sup>2)</sup>	NEPSI Ex d IIB T3...T6 Ga/Gb

1) Only in connection with Position 5, 6 = xN, xS

2) Only in connection with Position 5, 6 = xL, xM, xK

Position 5, 6 (Probe Length, Type)		
Selected option	Description	
FTL50	Ax	Compact
	Ix	Compact; temp. separator
	Qx	Compact; press.tight feed through
FTL50H	Ax	Compact
	Ix	Compact; temp. separator
	Qx	Compact; press.tight feed through
	xC	Ra < 1.5 µm
	xF	Ra < 0.76 µm
FTL51	BB, CB, DB	..... mm/in; 316L
	BE, CE, DE	..... mm/in; Alloy
	JB, KB, LB	..... mm/in; 316L + temp. separator
	JE, KE, LE	..... mm/in; Alloy + temp. separator
	RB, SB, TB	..... mm/in; 316L + press.tight feed through
	RE, SE, TE	..... mm/in; Alloy + press.tight feed through

Position 5, 6 (Probe Length, Type)		
Selected option		Description
FTL51H	Bx, Cx, Dx	..... mm/in
	Jx, Kx, Lx	..... mm/in; temp. separator
	Rx, Sx, Tx	..... mm/in; press.tight feed through
	xC	Ra <1.5 µm
	xF	Ra <0.76 µm
	FTL51C	xK
xL		PFA (Edlon)
xM		PFA (RubyRed)
xN		PFA (conductive)
xS		Enamel

Position 7 (Electronics, Output)		
Selected option		Description
FTL50(H)	A	FEL50A; PROFIBUS PA
FTL51(H) FTL51C	D	FEL50D; Density/Concentration, density electronics w/o WHG approval
	1	FEL51; SIL 2-wire 19-253 VAC
	2	FEL52; SIL 3-wire PNP 10-55 VDC
	4	FEL54; SIL relay DPDT 19-253 VAC, 19-55 VDC
	5	FEL55; SIL 8/16 mA, 11-36 VDC
	6	FEL56; SIL NAMUR (L-H signal)
	7	FEL57; SIL 2-wire PFM
	8	FEL58; SIL NAMUR+test button (H-L signal)

Position 8, 9 (Housing, Cable Entry)		
Selected option		Description
FTL50(H)	x1	F27; 316L
FTL51(H)	x5	F13; Alu
FTL51C		T13; Alu, coated.; separate conn. compartment
	Ex	NPT thread
	Fx	G1/2 thread
	Gx	M20 gland

Position 11 (Additional Option 2)		
Selected option		Description
FTL51C	A	Not selected
	B	Temp. separator
	C	2nd line of defence (press.tight feed through)

### Optional specifications

No options specific to hazardous locations are available.

### Extended order code: Liquiphant S



The following specifications reproduce an extract from the product structure and are used to assign:

- This documentation to the device (using the extended order code on the nameplate).
- The device options cited in the document.

### Device type

FTL70, FTL71

### Basic specifications

Position 1 (Approval)		
Selected option		Description
FTL7x	N	NEPSI Ex d IIC T2...T6 Ga/Gb

Position 5, 6 (Probe Length, Type)		
Selected option		Description
FTL70	AB	Compact; 316L
	AE	Compact; Alloy
FTL71	xB	..... mm/in; 316L
	xE	..... mm/in; Alloy

Position 7 (Electronics, Output)		
Selected option		Description
FTL7x	A	FEL50A; PROFIBUS PA
	1	FEL51; SIL 2-wire 19-253 VAC
	2	FEL52; SIL 3-wire PNP 10-55 VDC
	4	FEL54; SIL relay DPDT 19-253 VAC, 19-55 VDC
	5	FEL55; SIL 8/16 mA, 11-36 VDC
	6	FEL56; SIL NAMUR (L-H signal)
	7	FEL57; SIL 2-wire PFM
	8	FEL58; SIL NAMUR+test button (H-L signal)
	9	Special version: FEL50D

Position 8, 9 (Housing, Cable Entry)		
Selected option		Description
FTL7x	x1	F27; 316L
	x7	T13; Alu, coated.; separate conn. compartment
	x8	F13, Alu
	Ex	NPT thread
	Fx	G1/2 thread
	Gx	M20 gland

Position 11 (Application)		
Selected option		Description
FTL7x	L	230 °C, gas-tight feed through
	N	280 °C, gas-tight feed through
	Y	Special version: 300 °C

### *Optional specifications*

No options specific to hazardous locations are available.

### **Safety instructions:** **General**

- Staff must meet the following conditions for mounting, electrical installation, commissioning and maintenance of the device:
  - Be suitably qualified for their role and the tasks they perform
  - Be trained in explosion protection
  - Be familiar with national regulations
- For installation, use and maintenance of the device, users must also observe the requirements stated in the Operating Instructions and the standards:
  - GB 50257-2014: "Code for construction and acceptance of electric device for explosion atmospheres and fire hazard electrical equipment installation engineering".
  - GB 3836.13-2013: "Explosive atmospheres, Part 13: Equipment repair, overhaul and reclamation".
  - GB/T 3836.15-2017: "Explosive atmospheres, Part 15: Electrical installations design, selection and erection".
  - GB/T 3836.16-2017: "Explosive atmospheres, Part 16: Electrical installations inspection and maintenance".
  - GB 15577-2018: "Safety regulations for dust explosive prevention and protection". (Only if installed in dust hazardous area.)
- Install the device according to the manufacturer's instructions and national regulations.
- Do not operate the device outside the specified electrical, thermal and mechanical parameters.
- Only use the device in media to which the wetted materials have sufficient durability.
- Avoid electrostatic charging:
  - Of plastic surfaces (e.g. enclosure, sensor element, special varnishing, attached additional plates, ..)
  - Of isolated capacities (e.g. isolated metallic plates)
- Refer to the temperature tables for the relationship between the permitted ambient temperature for the sensor and/or transmitter, depending on the range of application and the temperature class.
- Modifications to the device can affect the explosion protection and must be carried out by staff authorized to perform such work by Endress+Hauser.
- Only open the device under the following condition: 17 minutes have elapsed since the power supply was switched off.

**Safety instructions:**

**Special conditions**

Permitted ambient temperature range at the electronics enclosure:  
→  14, "Temperature tables".

In the event of additional or alternative special varnishing on the housing or other metal parts:

- Observe the danger of electrostatic charging and discharge.
- Do not rub surfaces with a dry cloth.

*Basic specification, Position 8, 9 = x5, x7, x8*

Covers with glass window only permitted for the following ambient temperatures:

$$-50\text{ °C} \leq T_a \leq +70\text{ °C}$$

*Basic specification, Position 8, 9 = x1*

Covers with glass window not permitted.

*Basic specification, Position 8, 9 = x5, x7, x8*

Avoid sparks caused by impact and friction.

**Safety instructions:**  
**Installation**

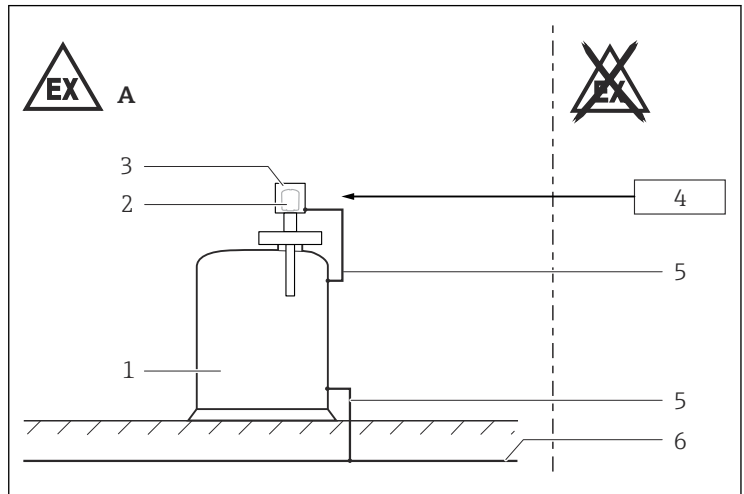

A0025536

 1

- A Zone 1
- 1 Tank; Zone 0, Zone 1
- 2 Electronic insert
- 3 Enclosure
- 4 Supply unit
- 5 Potential equalization line
- 6 Local potential equalization

- Before operation:
  - Screw in the cover all the way.
  - Tighten the securing clamp on the cover.
- In potentially explosive atmospheres:
  - Do not disconnect the electrical connection of the power supply circuit when energized.
  - Do not open the connection compartment cover and the electronics compartment cover when energized.
- Perform the following to achieve the degree of protection IP66/68:
  - Screw the cover tight.
  - Mount the cable entry correctly.
- Observe the maximum process conditions according to the manufacturer's Operating Instructions.
- At high medium temperatures, note flange pressure load capacity as a factor of temperature.
- Install the device to exclude any mechanical damage or friction during the application. Pay particular attention to flow conditions and tank fittings.
- Support extension tube of the device if a dynamic load is expected.
- Only use certified cable entries suitable for the application. Observe national regulations and standards. Accordingly, the connection terminal does not include any ignition sources.
- Seal unused entry glands with approved sealing plugs that correspond to the type of protection. The plastic transport sealing plug does not meet this requirement and must therefore be replaced during installation.
- The built-in metallic sealing plug is examined and approved for explosion protection type Ex d with the device.
- When operating the transmitter enclosure at an ambient temperature under  $-20\text{ }^{\circ}\text{C}$ , use appropriate cables and cable entries permitted for this application.
- When connecting through a conduit entry approved for this purpose, mount the associated sealing unit directly at the enclosure.

### **Accessory high pressure sliding sleeve**

The high pressure sliding sleeve can be used for a continuous setting of the switch point and is suited for zone separation if mounted properly (see Operating Instructions).

### **Potential equalization**

Integrate the device into the local potential equalization.

## **Safety instructions: Ex d joints**

- If required or if in doubt: ask manufacturer for specifications.
- Flameproof joints are not intended to be repaired.

## Safety instructions:

### Zone 0

- In the event of potentially explosive vapor/air mixtures, only operate the device under atmospheric conditions.
  - Temperature: -20 to +60 °C
  - Pressure: 80 to 110 kPa (0.8 to 1.1 bar)
  - Air with normal oxygen content, usually 21 % (V/V)
- If no potentially explosive mixtures are present, or if additional protective measures have been taken, the device may also be operated under non-atmospheric conditions in accordance with the manufacturer's specifications.
- Only use the device in media to which the wetted materials have sufficient durability (e.g. process connection seal).
- When using under non-atmospheric pressures and non-atmospheric temperatures: The sensor part of the device approved for Zone 0 does not cause any ignition hazards.

## Explosion protection with heat insulation

*Device type FTL70, FTL71, Basic specification, Position 11 = L, N, Y*

- While observing the "temperature derating", the device is suitable for process temperatures up to 300 °C.
- When operating, ensure that you rule out contact between hot component surfaces and potentially explosive atmospheres beyond the limits of the corresponding temperature class. Suitable measures: e.g. thermal insulation at container and/or pipes.
- The temperature of 85 °C specified at the reference point may not be exceeded.
- To protect the electronics, observe the specified ambient temperature at the electronics enclosure.

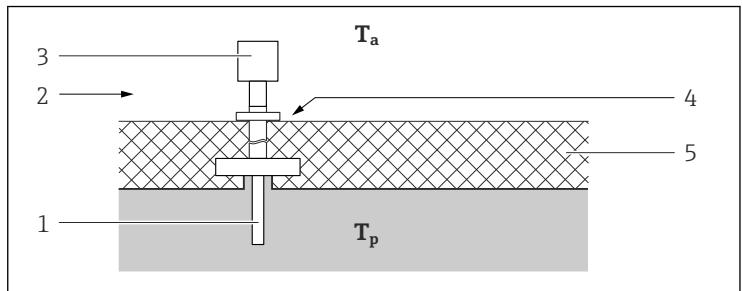

A0025541

2

$T_a$  Ambient temperature

$T_p$  Process temperature

1 Sensor

2 Temperature class, e.g. T6

3 Enclosure



4 Reference point: max. +85 °C

5 E.g. thermal insulation

## Temperature tables

Device type *FTL50, FTL50H, FTL51, FTL51H* and



Device type *FTL51C, Basic specification, Position 5, 6 = xL, xM, xN, xS*

Temperature class	Process temperature $T_p$ (process): sensor	Ambient temperature $T_a$ (ambient): electronics
T6	-50 to +75 °C	-60 to +70 °C <sup>1)2)</sup> Covers with glass window: -50 to +70 °C <sup>1)2)</sup>
T5	-50 to +90 °C	-60 to +70 °C <sup>1)2)</sup> Covers with glass window: -50 to +70 °C <sup>1)2)</sup> with temperature separator; without temperature separator →  3,  15
T4	-50 to +125 °C	
T3	-50 to +150 °C	

1) Basic specification, Position 7 = 4: T6:  $T_{a,max} = +55$  °C and relay current  $I_{max} \leq 4$  A

2) Basic specification, Position 7 = 4: T5:  $T_{a,max} = +70$  °C and relay current  $I_{max} \leq 4$  A



Device type *FTL51C, Basic specification, Position 5, 6 = xK*

Temperature class	Process temperature $T_p$ (process): sensor	Ambient temperature $T_a$ (ambient): electronics
T6	-50 to +75 °C	-60 to +70 °C <sup>1)2)</sup> Covers with glass window: -50 to +70 °C <sup>1)2)</sup>
T5	-50 to +90 °C	-60 to +70 °C <sup>1)2)</sup> Covers with glass window: -50 to +70 °C <sup>1)2)</sup> with temperature separator; without temperature separator →  3,  15
T4	-50 to +120 °C	

1) Basic specification, Position 7 = 4: T6:  $T_{a,max} = +55$  °C and relay current  $I_{max} \leq 4$  A

2) Basic specification, Position 7 = 4: T5:  $T_{a,max} = +70$  °C and relay current  $I_{max} \leq 4$  A

Device type *FTL70, FTL71*

Temperature class	Process temperature $T_p$ (process): sensor	Ambient temperature $T_a$ (ambient): electronics
T6	-60 to +75 °C	-60 to +70 °C <sup>1)2)</sup> Covers with glass window: -50 to +70 °C <sup>1)2)</sup>
T5	-60 to +90 °C	
T4	-60 to +125 °C	
T3	-60 to +190 °C	-60 to +70 °C Covers with glass window: -50 to +70 °C Restrictions →  4,  16
T2	-60 to +230 °C (L) -60 to +280 °C (N) -60 to +285 °C (Y)	
T1	-60 to +300 °C (Y)	

1) Basic specification, Position 7 = 4: T6:  $T_{a,max} = +55$  °C and relay current  $I_{max} \leq 4$  A

2) Basic specification, Position 7 = 4: T5:  $T_{a,max} = +70$  °C and relay current  $I_{max} \leq 4$  A

## Device type FTL50, FTL50H, FTL51, FTL51H, FTL51C

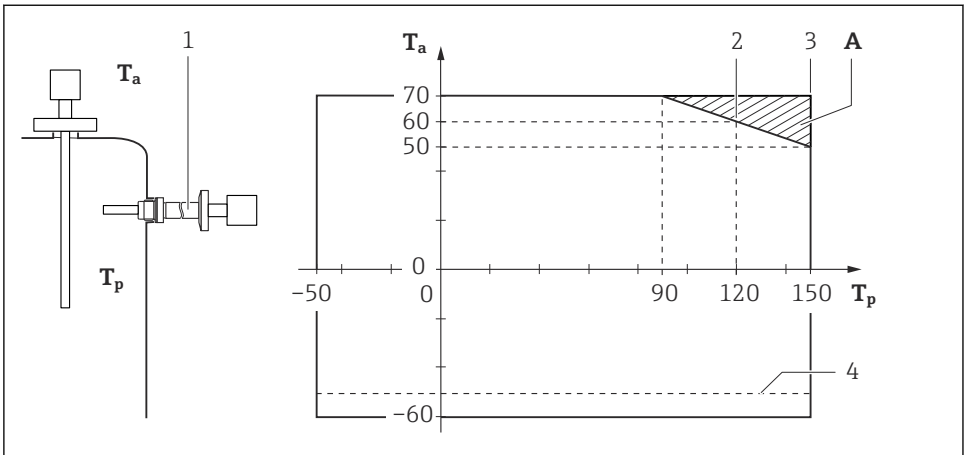

A002554

3

 $T_a$  Ambient temperature in °C $T_p$  Process temperature in °C

A Additional temperature range for devices with temperature separator or pressure-tight feed through

1 Temperature separator or pressure tight feed through

2 ECTFE

3 PFA, Enamel, 316L, Alloy

4 Covers with glass window:  $T_a = -50$  °C

Device type FTL70, FTL71

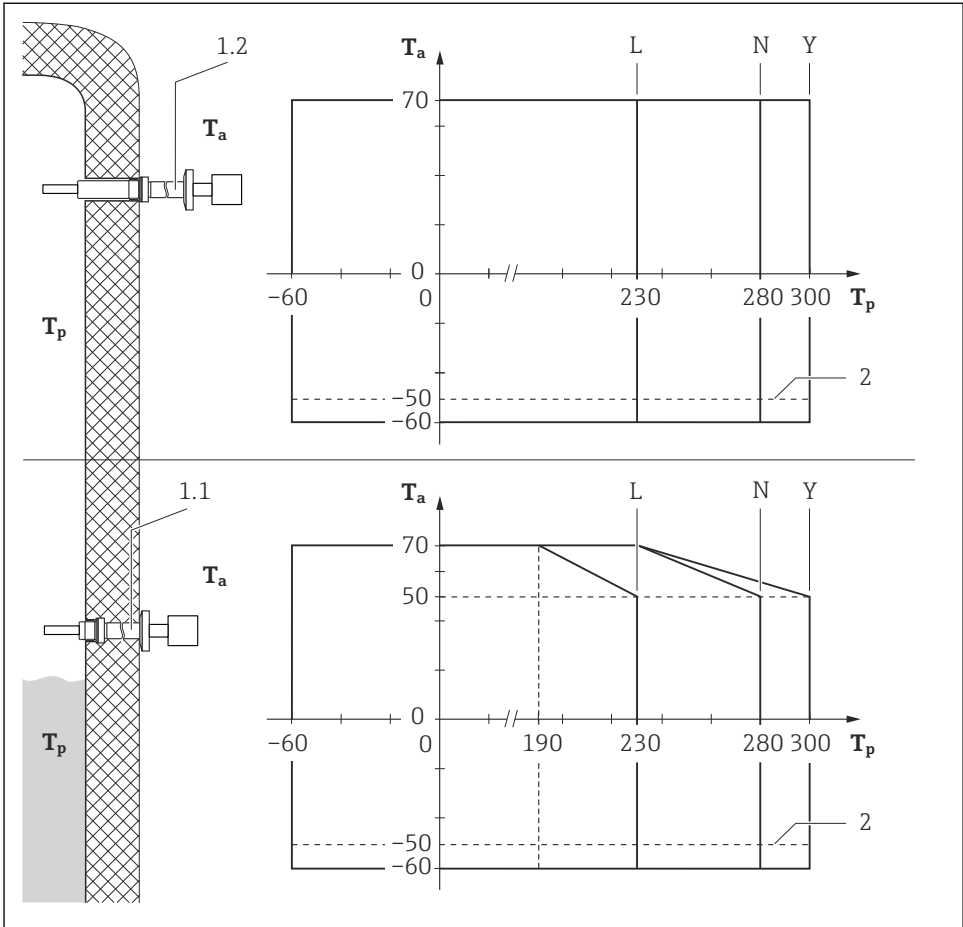

A0033706

4

- $T_a$  Ambient temperature in °C
- $T_p$  Process temperature in °C
- 1 Temperature separator:
  - 1.1 insulated
  - 1.2 free-standing
- 2 Covers with glass window:  $T_a = -50$  °C

**Connection data**

<i>Basic specification, Position 7</i>	<b>Power supply circuit</b>	<b>Output</b>
A	For connection to a Fieldbus	PROFIBUS PA or FOUNDATION Fieldbus
D (FTL5x(H), FTL51C) 9 (FTL7x)	Only associated intrinsically safe power supply unit FML621 from Endress+Hauser	
1	U = 19 to 253 V <sub>AC</sub> , 50/60 Hz; max. 0.96 VA	max. 350 mA
2	U = 10 to 55 V <sub>DC</sub> ; max. 0.83 W	PNP transistor; max. 350 mA
4	U = 19 to 253 V <sub>AC</sub> , 50/60 Hz or 19 to 55 V <sub>DC</sub> ; max. 1.3 W	2 potential free change-over contacts; 4 A Ex d
5	U = 11 to 36 V <sub>DC</sub> ; max. 0.6 W	max. 22 mA
6	U = 4 to 12.5 V <sub>DC</sub> ; max. 0.23 W	NAMUR; max. 3.5 mA
7	U = max. 16.7 V <sub>DC</sub> ; max. 0.15 W	PFM; max. 12 mA
8	U = 4 to 12.5 V <sub>DC</sub> ; max. 0.23 W	NAMUR; max. 3.5 mA







71543501

[www.addresses.endress.com](http://www.addresses.endress.com)

---