

Brief Operating Instructions

Flowmeter

Proline 10

Modbus RS485 transmitter
with electromagnetic sensor

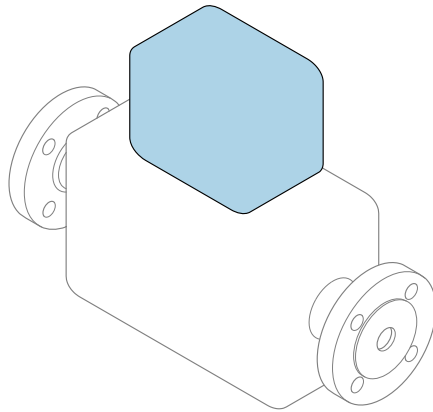

These instructions are Brief Operating Instructions; they are **not** a substitute for the Operating Instructions pertaining to the device.

Brief Operating Instructions part 2 of 2: Transmitter
Contain information about the transmitter.

Brief Operating Instructions part 1 of 2: Sensor →  3



A0023555

Brief Operating Instructions for flowmeter

The device consists of a transmitter and a sensor.

The process of commissioning these two components is described in two separate manuals that together form the Brief Operating Instructions for the flowmeter:

- Brief Operating Instructions Part 1: Sensor
- Brief Operating Instructions Part 2: Transmitter

Please refer to both parts of the Brief Operating Instructions when commissioning the device, as the contents of the manuals complement one another:

Brief Operating Instructions Part 1: Sensor

The Sensor Brief Operating Instructions are aimed at specialists with responsibility for installing the measuring device.

- Incoming acceptance and product identification
- Storage and transport
- Installation

Brief Operating Instructions Part 2: Transmitter

The Transmitter Brief Operating Instructions are aimed at specialists with responsibility for commissioning, configuring and parameterizing the measuring device (until the first measured value).

- Product description
- Installation
- Electrical connection
- Operation options
- System integration
- Commissioning
- Diagnostic information

Additional device documentation



These Brief Operating Instructions are **Brief Operating Instructions Part 2: Transmitter**.

The "Brief Operating Instructions Part 1: Sensor" are available via:

- Internet: www.endress.com/deviceviewer
- Smart phone/tablet: *Endress+Hauser Operations App*

Detailed information about the device can be found in the Operating Instructions and the other documentation:

- Internet: www.endress.com/deviceviewer
- Smart phone/tablet: *Endress+Hauser Operations App*

Table of contents

1	About this document	5
1.1	Symbols	5
2	Safety instructions	6
2.1	Requirements for specialist personnel	6
2.2	Requirements for operating personnel	6
2.3	Incoming acceptance and transport	6
2.4	Adhesive labels, tags and engravings	7
2.5	Environment and process	7
2.6	Workplace safety	7
2.7	Installation	7
2.8	Electrical connection	7
2.9	Surface temperature	7
2.10	Commissioning	7
2.11	Modifications to the device	7
3	Product information	8
3.1	Designated use	8
3.2	Product design	9
4	Installation	11
4.1	Turning the transmitter housing	11
4.2	Post-installation check	12
5	Electrical connection	13
5.1	Connection conditions	13
5.2	Requirements for connecting cable	13
5.3	Ground cable requirements	14
5.4	Connecting cable requirements	15
5.5	Connecting cable connection	17
5.6	Connecting the transmitter	26
5.7	Ensuring potential matching Promag D, P, W	29
5.8	Ensuring potential equalization Promag H	35
5.9	Removing a cable	37
5.10	Examples for electric terminals	38
5.11	Post-connection check	40
6	Operation	41
6.1	Overview of the operating options	41
6.2	Local operation	41
6.3	SmartBlue App	48
7	System integration	49
8	Commissioning	49
8.1	Post-installation check and post-connection check	49
8.2	Switching on the device	50
8.3	Commissioning the device	51
8.4	Protecting settings from unauthorized access	53
9	Diagnostics and troubleshooting	53
9.1	Diagnostic information on local display	53

1 About this document

1.1 Symbols

1.1.1 Warnings

DANGER

This symbol alerts you to an immediate dangerous situation. Failure to avoid the situation will result in a fatal or serious injury.

WARNING

This symbol alerts you to a potentially dangerous situation. Failure to avoid the situation may result in a fatal or serious injury.





CAUTION

This symbol alerts you to a potentially dangerous situation. Failure to avoid the situation may result in a minor or mild injury.





NOTICE

This symbol alerts you to a potentially harmful situation. Failure to avoid the situation may result in damage to the facility or to something in the facility's vicinity.



1.1.2 Electronics

-  Direct current
-  Alternating current
-  Direct current and alternating current
-  Protective earthing



1.1.3 Device communication











-  Bluetooth is enabled.
-  LED is off.
-  LED flashing.
-  LED lit.

1.1.4 Tools



-  Flat blade screwdriver
-  Hexagon wrench
-  Wrench

1.1.5 Types of information

-  Preferred procedures, processes or actions
-  Permitted procedures, processes or actions

-  Forbidden procedures, processes or actions
-  Additional information
-  Reference to documentation
-  Reference to page
-  Reference to graphic
-  Measure or individual action to be observed
-  1., 2.,... Series of steps
-  Result of a step
-  Help in the event of a problem
-  Visual inspection
-  Write-protected parameter

1.1.6 Explosion protection

-  Hazardous area
-  Non-hazardous area

2 Safety instructions

2.1 Requirements for specialist personnel

- ▶ Installation, electrical connection, commissioning, diagnostics and maintenance of the device must only be carried out by trained, specialist personnel authorized by the facility's owner-operator.
- ▶ Before commencing work, the trained, specialist personnel must carefully read, understand and adhere to the Operating Instructions, additional documentation and certificates.
- ▶ Comply with national regulations.

2.2 Requirements for operating personnel

- ▶ Operating personnel are authorized by the facility's owner-operator and are instructed according to the requirements of the task.
- ▶ Before commencing work, the operating personnel must carefully read, understand and adhere to the instructions provided in the Operating Instructions and additional documentation.

2.3 Incoming acceptance and transport

- ▶ Transport the device in a correct and appropriate manner.
- ▶ Do not remove protective covers or protective caps on the process connections.

2.4 Adhesive labels, tags and engravings

- ▶ Pay attention to all the safety instructions and symbols on the device.

2.5 Environment and process

- ▶ Only use the device for the measurement of appropriate media.
- ▶ Keep within the device-specific pressure range and temperature range.
- ▶ Protect the device from corrosion and the influence of environmental factors.

2.6 Workplace safety

- ▶ Wear the required protective equipment according to national regulations.
- ▶ Do not ground the welding unit by means of the device.
- ▶ Wear protective gloves if working on and with the device with wet hands.

2.7 Installation

- ▶ Do not remove protective covers or protective caps on the process connections until just before you install the sensor.
- ▶ Do not damage or remove the liner on the flange.
- ▶ Observe tightening torques.

2.8 Electrical connection

- ▶ Comply with national installation regulations and guidelines.
- ▶ Observe cable specifications and device specifications.
- ▶ Check the cable for damage.
- ▶ If using the device in hazardous areas, observe the "Safety Instructions" documentation.
- ▶ Provide (establish) potential equalization.
- ▶ Provide (establish) grounding.

2.9 Surface temperature

Media with elevated temperatures can cause the surfaces of the device to become hot. For this reason, note the following:

- ▶ Mount suitable touch protection.
- ▶ Wear suitable protective gloves.

2.10 Commissioning

- ▶ Install the device only if it is in proper technical condition, free from errors and faults.
- ▶ Only put the device into operation once you have performed the post-installation check and post-connection check.

2.11 Modifications to the device

- ▶ Only carry out modifications or repairs after consulting beforehand with an Endress+Hauser service organization.
- ▶ Install spare parts and accessories according to the Installation Instructions.

- ▶ Only use original spare parts and original accessories from Endress+Hauser.

3 Product information

3.1 Designated use

The device is intended only for the flow measurement of liquids and gases.

Depending on the version ordered, the device measures potentially explosive, flammable, poisonous and oxidizing media.

Devices for use in a hazardous area, in hygienic applications, or where there is an increased risk due to process pressure, are labeled accordingly on the nameplate.

Non-designated use can compromise safety. The manufacturer is not liable for damage caused by improper or non-designated use.

3.2 Product design

3.2.1 Compact version

The transmitter and sensor form a mechanical unit.

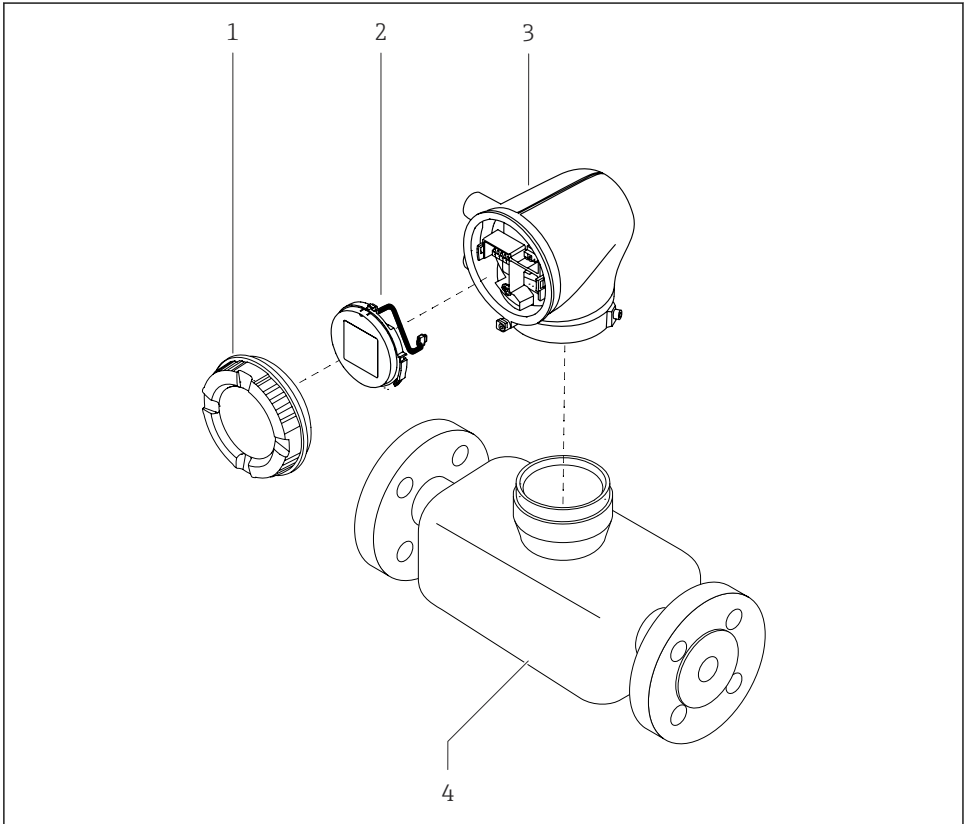

A0043525

1 Main device components

- 1 Housing cover
- 2 Display module
- 3 Transmitter housing
- 4 Sensor

3.2.2 Remote version

The transmitter and sensor are installed in physically separate locations.

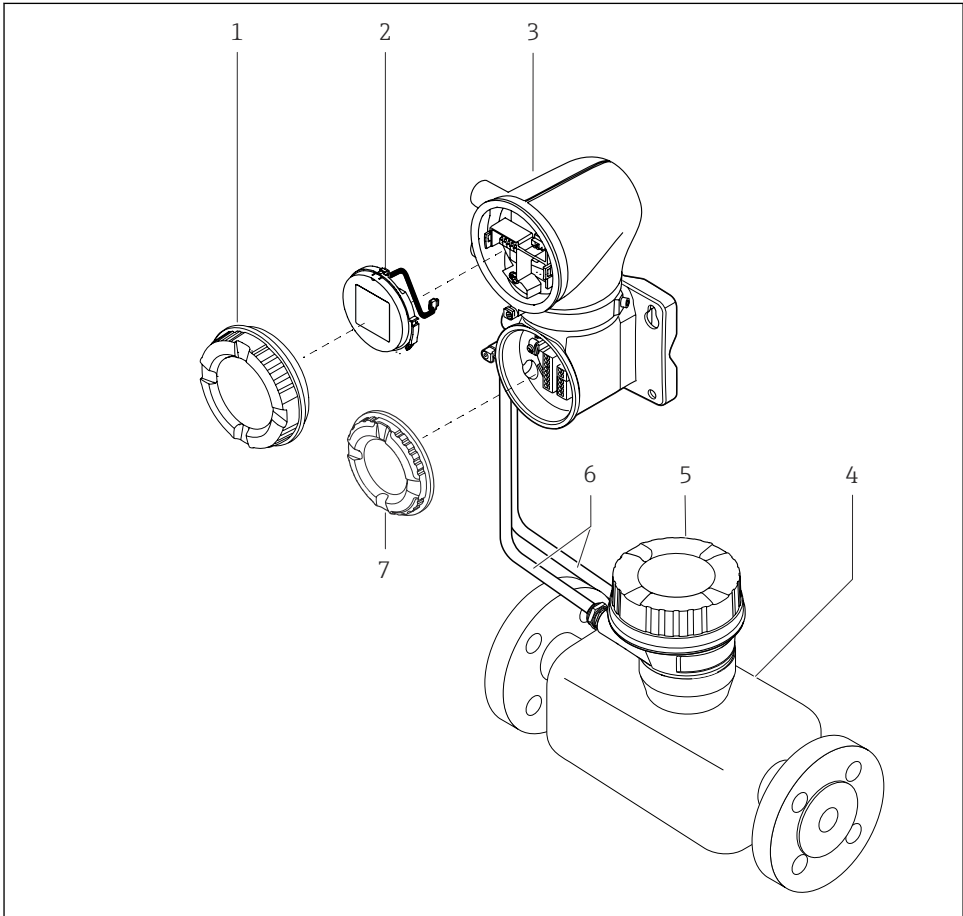

A0043524

2 Main device components

- 1 Housing cover
- 2 Display module
- 3 Transmitter housing
- 4 Sensor
- 5 Sensor connection housing
- 6 Connecting cable consisting of coil current cable and electrode cable
- 7 Connection compartment cover

4 Installation



For detailed information about installing the sensor, see the Brief Operating Instructions for the sensor → 3

4.1 Turning the transmitter housing

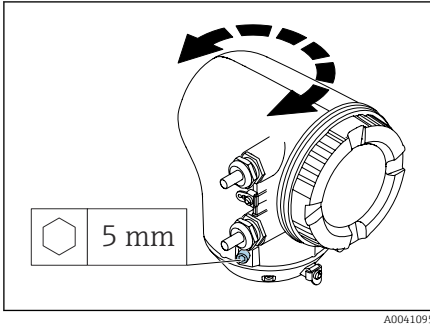

1. Loosen the fixing screws on both sides of the transmitter housing.

2. **NOTICE**

Overrotation of the transmitter housing!

Interior cables are damaged.

- ▶ Turn the transmitter housing a maximum of 180° in each direction.

Turn the transmitter housing to the desired position.

3. Tighten the screws in the logically reverse sequence.

4.2 Post-installation check

Is the device undamaged (visual inspection)?	<input type="checkbox"/>
Does the device comply with the measuring point specifications?	
For example:	
<ul style="list-style-type: none"> ■ Process temperature ■ Process pressure ■ Ambient temperature ■ Measuring range 	<input type="checkbox"/>
Has the correct orientation been selected for the device?	<input type="checkbox"/>
Does the direction of the arrow on the device match the flow direction of the medium?	<input type="checkbox"/>
Is the device protected against precipitation and sunlight?	<input type="checkbox"/>
Are the screws tightened with the correct tightening torque?	<input type="checkbox"/>

5 Electrical connection

5.1 Connection conditions

5.1.1 Notes on the electrical connection

⚠ WARNING

Components carry voltage!

Incorrect work performed on the electrical connections can result in an electric shock.

- ▶ Have electrical connection work carried out by appropriately trained specialists only.
- ▶ Comply with applicable federal/national installation codes and regulations.
- ▶ Comply with national and local workplace safety regulations.
- ▶ Establish the connections in the correct order: always make sure to first connect the protective earth (PE) to the inner ground terminal.
- ▶ When using in hazardous areas, observe the "Safety Instructions" document.
- ▶ Ground the device carefully and provide potential equalization.
- ▶ Connect protective earthing to all outer ground terminals.

5.1.2 Additional protective measures

The following protective measures are required:

- Set up a disconnecting device (switch or power-circuit breaker) to easily disconnect the device from the supply voltage.
- In addition to the device fuse, include an overcurrent protection unit, with max. 10 A, in the facility installation.
- Plastic sealing plugs act as safeguards during transportation and must be replaced by suitable, individually approved installation material.
- Connection examples: →  38

5.1.3 Connecting the cable shield



To avoid power (mains) frequency equalizing currents over the cable shield, the potential equalization of the facility must be ensured. If potential equalization (equipotential bonding) of the facility is not possible, only connect the cable shield to the facility on one side. Shielding against electromagnetic interference is then only partially ensured.

1. Keep stripped and twisted cable shields to the inner ground terminal as short as possible.
2. Shield cables fully.
3. Connect the cable shield to the potential equalization of the facility on both sides.

5.2 Requirements for connecting cable

5.2.1 Electrical safety

As per applicable national regulations.

5.2.2 Permitted temperature range

- Observe the installation guidelines that apply in the country of installation.
- The cables must be suitable for the minimum temperatures and maximum temperatures to be expected.

5.2.3 Power supply cable (incl. conductor for the inner ground terminal)

- A standard installation cable is sufficient.
- Provide grounding according to applicable national codes and regulations.

5.2.4 Signal cable

- Modbus RS485:
 - Cable type A according to EIA/TIA-485 standard is recommended
- Current output 4 to 20 mA:
 - Standard installation cable

5.3 Ground cable requirements

Copper wire: at least 6 mm² (0.0093 in²)

5.4 Connecting cable requirements

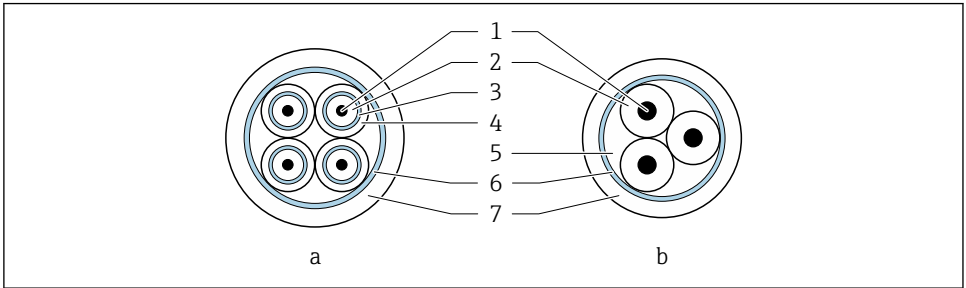

A0029151

3 Cable cross-section

- a* Electrode cable
- b* Coil current cable
- 1 Core
- 2 Core insulation
- 3 Core shield
- 4 Core jacket
- 5 Core reinforcement
- 6 Cable shield
- 7 Outer jacket



Preterminated connecting cables

Two connecting cable versions can be ordered from Endress+Hauser for use with IP68 protection:

- Cable is already connected to the sensor.
- Cable is connected by the customer (incl. tools for sealing the connection compartment).



Armored connecting cable

Armored connecting cables with additional, metal reinforcing braid can be ordered from Endress+Hauser. Armored connecting cables are used:

- When laying the cable directly in the ground
- Where there is a risk of damage from rodents
- If using the device below IP68 degree of protection

5.4.1 Electrode cable

Design	<p>3×0.38 mm² (20 AWG) with common, braided copper shield (∅ ~ 9.5 mm (0.37 in)) and individual shielded cores</p> <p>If using the empty pipe detection (EPD) function: 4×0.38 mm² (20 AWG) with common, braided copper shield (∅ ~ 9.5 mm (0.37 in)) and individual shielded cores</p>
Conductor resistance	≤ 50 Ω/km (0.015 Ω/ft)
Capacitance: core/shield	≤ 420 pF/m (128 pF/ft)
Cable length	Depending on the medium conductivity: maximum 200 m (656 ft)
Cable lengths (available for order)	5 m (15 ft), 10 m (30 ft), 20 m (60 ft) or variable length: maximum 200 m (656 ft) Armored cables: variable length up to maximum 200 m (656 ft)
Operating temperature	-20 to +80 °C (-4 to +176 °F)

5.4.2 Coil current cable

Design	3×0.38 mm ² (20 AWG) with common, braided copper shield (∅ ~ 9.5 mm (0.37 in)) and individual shielded cores
Conductor resistance	≤ 37 Ω/km (0.011 Ω/ft)
Capacitance: core/shield	≤ 120 pF/m (37 pF/ft)
Cable length	Depends on the medium conductivity, max. 200 m (656 ft)
Cable lengths (available for order)	5 m (15 ft), 10 m (30 ft), 20 m (60 ft) or variable length up to max. 200 m (656 ft) Armored cables: variable length up to max. 200 m (656 ft)
Operating temperature	-20 to +80 °C (-4 to +176 °F)
Test voltage for cable insulation	≤ AC 1 433 V r.m.s. 50/60 Hz or ≥ DC 2 026 V

5.5 Connecting cable connection

5.5.1 Preparing the connecting cable

Coil current cable

Promag D, P, W

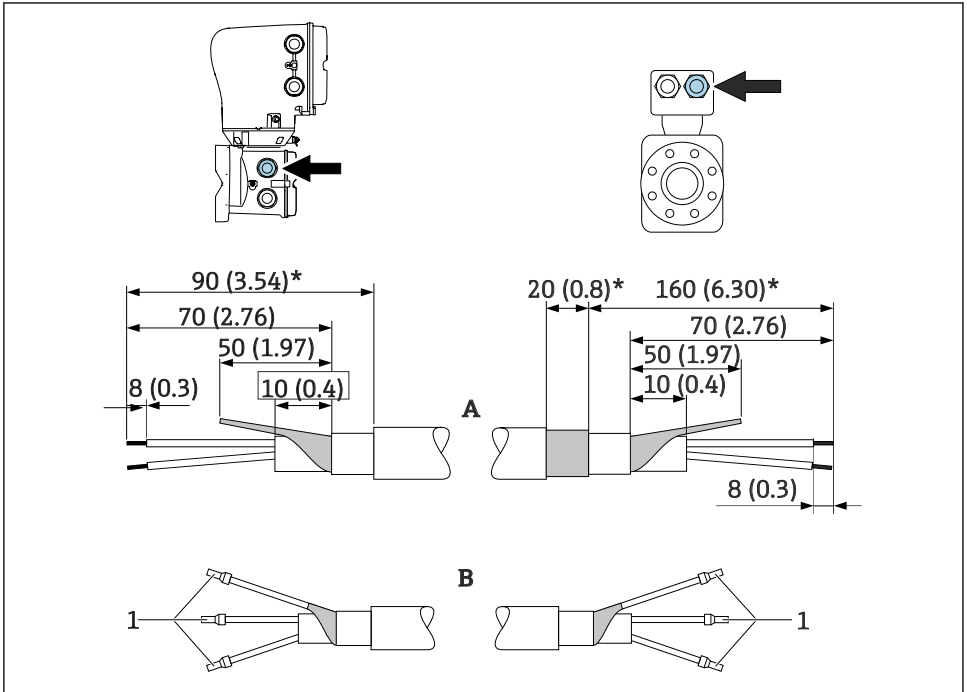

A0042278

1 Ferrules, red $\phi 1.0\text{ mm}$ (0.04 in)

1. Insulate one core of the three-core cable at the level of the core reinforcement. Only 2 cores are required for the connection.
2. A: Terminate coil current cable, strip reinforced cables (*).
3. B: Fit ferrules over the strands and press in place.
4. Insulate the cable shield on the transmitter side, e.g. heat shrink tube.

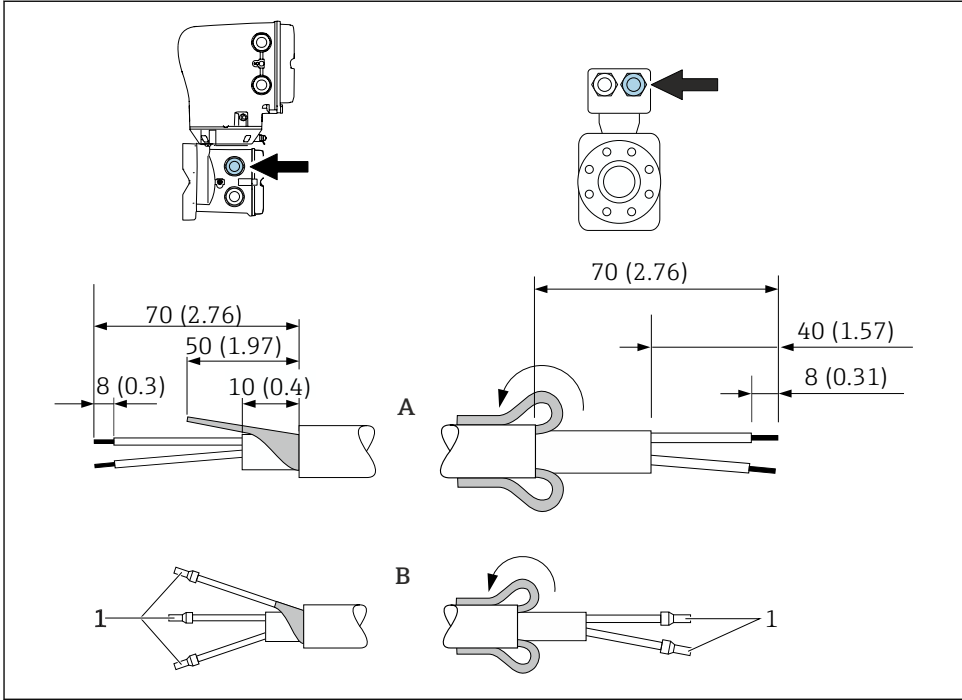
Promag H

1 Ferrules, red $\phi 1.0$ mm (0.04 in)

1. Insulate one core of the three-core cable at the level of the core reinforcement. Only 2 cores are required for the connection.
2. A: Terminate the coil current cable.
3. B: Fit ferrules over the strands and press in place.
4. Fit the cable shield on the sensor side over the outer jacket.
5. Insulate the cable shield on the transmitter side, e.g. heat shrink tube.

Electrode cable

Promag D, P, W

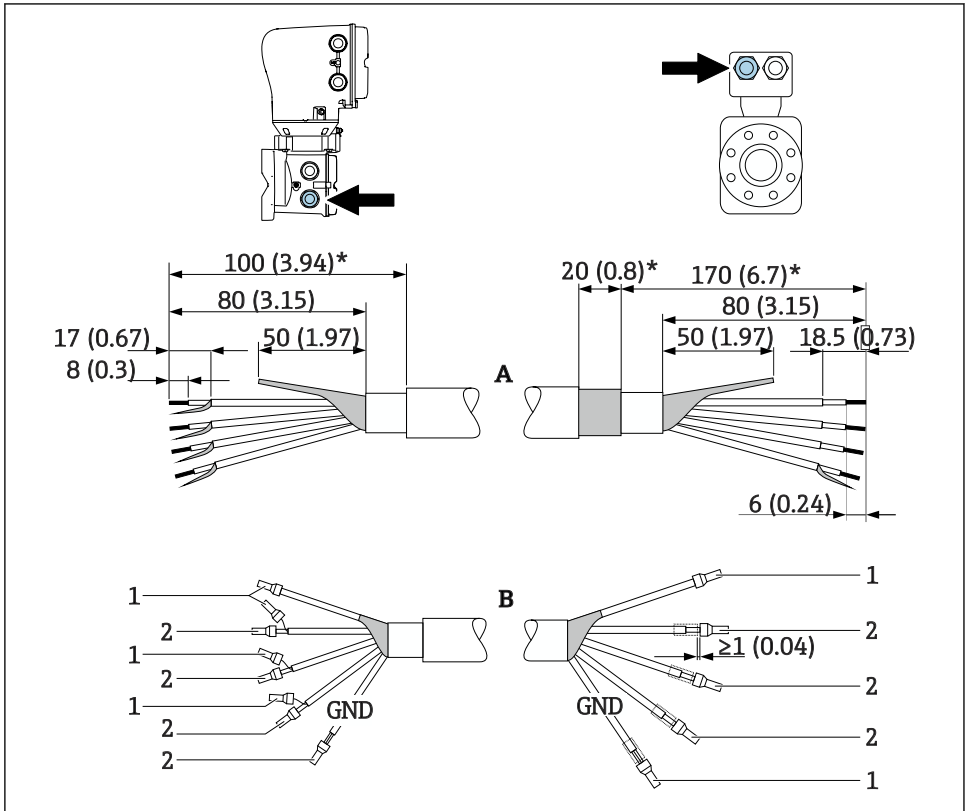

A0042424

- 1 Ferrules, red $\phi 1.0$ mm (0.04 in)
- 2 Ferrules, white $\phi 0.5$ mm (0.02 in)

1. Make sure that the ferrules do not touch the cable shields on the sensor side. Minimum distance = 1 mm (exception: green "GND" cable)
2. A: Terminate electrode cable, strip reinforced cables (*).
3. B: Fit ferrules over the strands and press in place.
4. Insulate the cable shield on the transmitter side, e.g. heat shrink tube.

5.5.2 Connecting the connecting cable

Connecting cable terminal assignment

Promag D, P, W

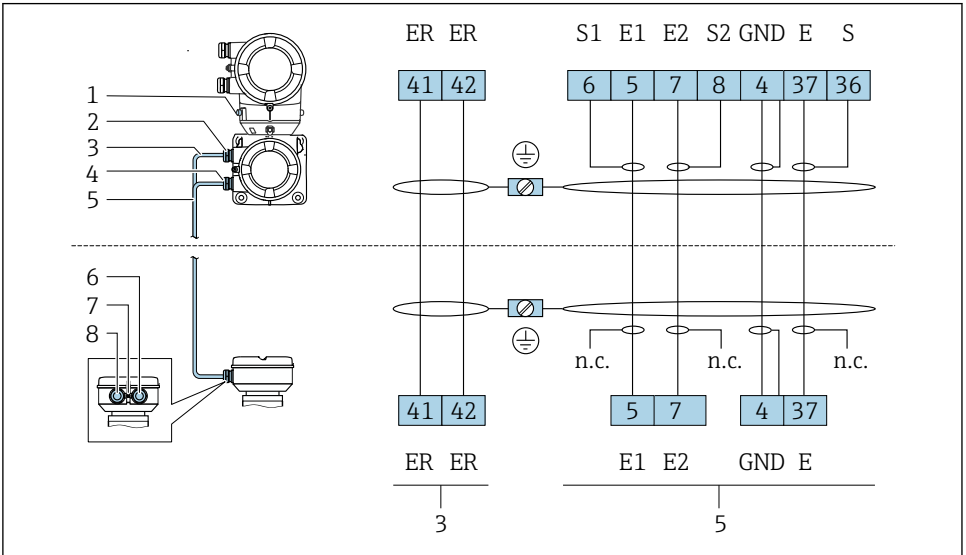

A0043474

- 1 Ground terminal, outer
- 2 Transmitter housing: cable entry for coil current cable
- 3 Coil current cable
- 4 Transmitter housing: cable entry for electrode cable
- 5 Electrode cable
- 6 Sensor connection housing: cable entry for electrode cable
- 7 Ground terminal, outer
- 8 Sensor connection housing: cable entry for coil current cable

Promag H

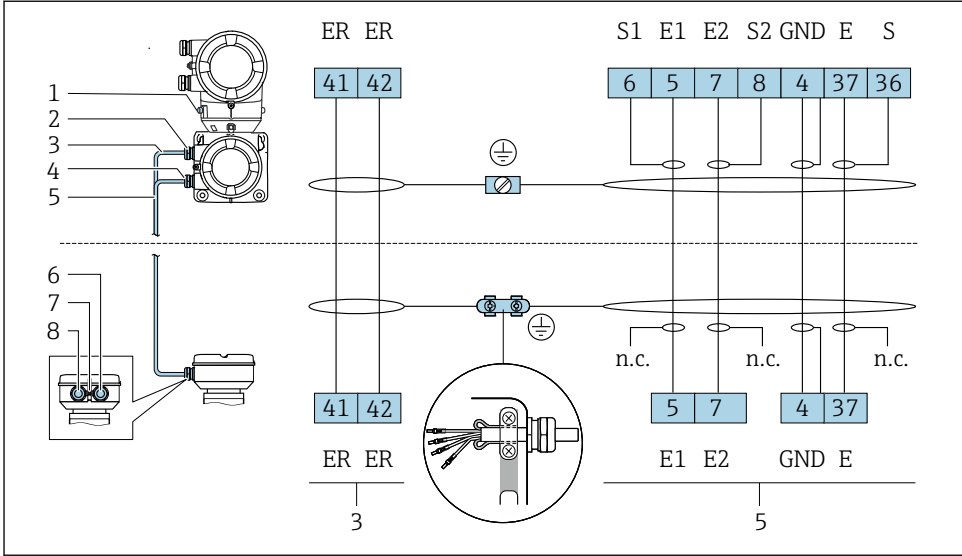

- 1 Ground terminal, outer
- 2 Transmitter housing: cable entry for coil current cable
- 3 Coil current cable
- 4 Transmitter housing: cable entry for electrode cable
- 5 Electrode cable
- 6 Sensor connection housing: cable entry for electrode cable
- 7 Ground terminal, outer
- 8 Sensor connection housing: cable entry for coil current cable

Wiring the sensor connection housing

NOTICE**Incorrect wiring can damage the electronic components!**

- ▶ Only connect sensors and transmitters with identical serial numbers.
- ▶ Connect the sensor connection housing and the transmitter housing to the potential equalization of the facility via the outer ground terminal.
- ▶ Connect the sensor and transmitter to the same potential.

Aluminum sensor connection housing

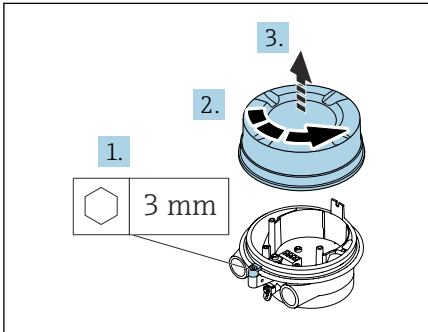

A0044138

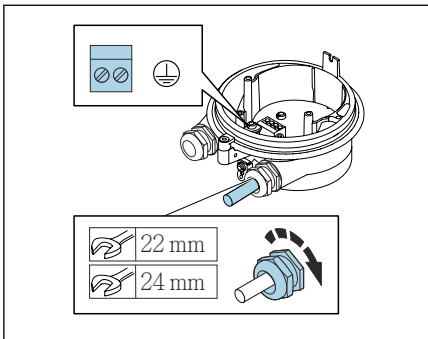

A0044139

1. Loosen the Allen key of the securing clamp.
2. Unscrew the connection compartment cover in the counterclockwise direction.

NOTICE

If the sealing ring is missing, the housing is not sealed tight!

Damage to the device.

- ▶ Do not remove the sealing ring from the cable entry.
3. Feed the coil current cable and electrode cable through the corresponding cable entry.
 4. Adjust the cable lengths.
 5. connect the cable shield to the inner ground terminal.
 6. Strip the cable and cable ends.
 7. Fit ferrules over the strands and press in place.
 8. Connect the coil current cable and the electrode cable as per the terminal assignment.
 9. Tighten the cable glands.
 10. Screw on the connection compartment cover.
 11. Fasten the securing clamp.

Stainless steel sensor connection housing

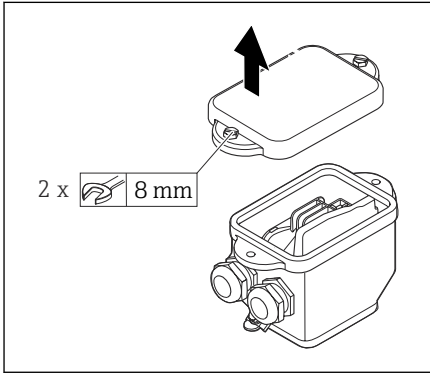

A0044737

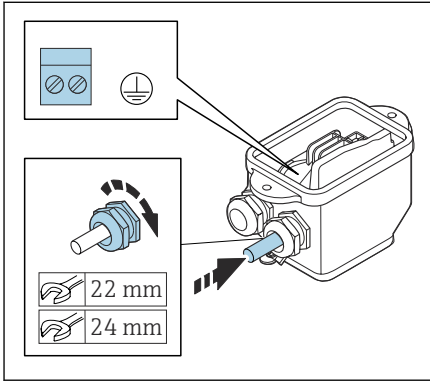

A0044738

1. Loosen the hexagonal-headed bolt of the connection compartment cover.
2. Remove the connection compartment cover.

NOTICE

If the sealing ring is missing, the housing is not sealed tight!

Damage to the device.

- ▶ Do not remove the sealing ring from the cable entry.
3. Feed the coil current cable and electrode cable through the corresponding cable entry.
 4. Adjust the cable lengths.
 5. Connect the cable shield to the strain relief clamp.
 6. Strip the cable and cable ends.
 7. Fit ferrules over the strands and press in place.
 8. Connect the coil current cable and the electrode cable as per the terminal assignment.
 9. Tighten the cable glands.
 10. Screw on the connection compartment cover.

Wiring the transmitter housing

NOTICE

Incorrect wiring can damage the electronic components!

- ▶ Only connect sensors and transmitters with identical serial numbers.
- ▶ Connect the sensor connection housing and the transmitter housing to the potential equalization of the facility via the outer ground terminal.
- ▶ Connect the sensor and transmitter to the same potential.

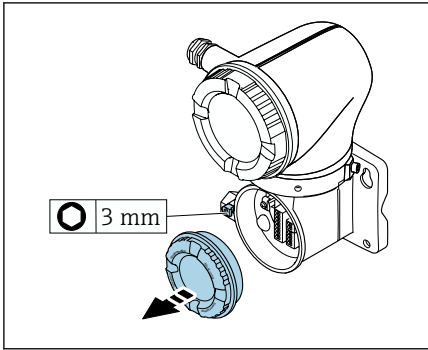

A0042376

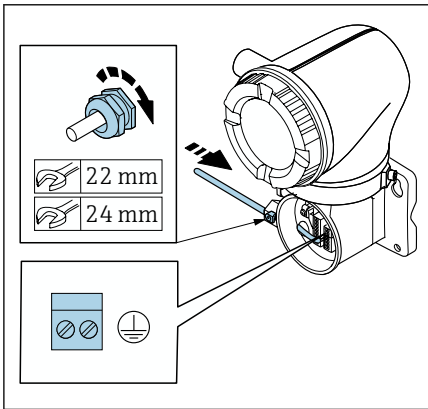

A0042371

1. Loosen the Allen key of the securing clamp.
2. Unscrew the connection compartment cover in the counterclockwise direction.

NOTICE

If the sealing ring is missing, the housing is not sealed tight!

Damage to the device.

- ▶ Do not remove the sealing ring from the cable entry.
3. Feed the coil current cable and electrode cable through the corresponding cable entry.
 4. Adjust the cable lengths.
 5. Connect the cable shields to the inner ground terminal.
 6. Strip the cable and cable ends.
 7. Fit ferrules over the strands and press in place.
 8. Connect the coil current cable and the electrode cable as per the terminal assignment.
 9. Tighten the cable glands.
 10. Screw on the connection compartment cover.
 11. Fasten the securing clamp.

5.6 Connecting the transmitter

5.6.1 Transmitter terminal connections

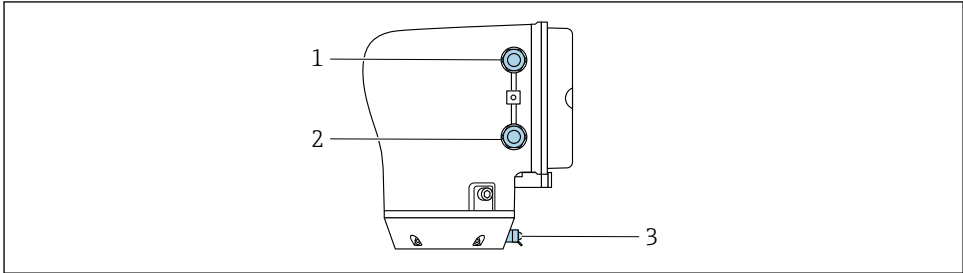

A0045438

- 1 Cable entry for power supply cable: supply voltage
- 2 Cable entry for signal cable
- 3 Ground terminal, outer

5.6.2 Terminal assignment

 The terminal assignment is documented on an adhesive label.

The following terminal assignment is available:



Modbus RS485 and current output 4 to 20 mA (active)

Supply voltage		Output 1				Output 2	
1 (+)	2 (-)	26 (+)	27 (-)	24 (+)	25 (-)	22 (B)	23 (A)
L/+	N/-	Current output 4 to 20 mA (active)		-		Modbus RS485	

Modbus RS485 and current output 4 to 20 mA (passive)

Supply voltage		Output 1				Output 2	
1 (+)	2 (-)	26 (+)	27 (-)	24 (+)	25 (-)	22 (B)	23 (A)
L/+	N/-	-		Current output 4 to 20 mA (passive)		Modbus RS485	

5.6.3 Wiring the transmitter

-  Use a suitable cable gland for the power supply cable and signal cable.
-  Pay attention to the requirements for the power supply cable and signal cable
→  13 .
- Use shielded cables for digital communication.

NOTICE

If the cable gland is incorrect, this compromises the sealing of the housing!

Damage to the device.

- ▶ Use a suitable cable gland corresponding to the degree of protection.

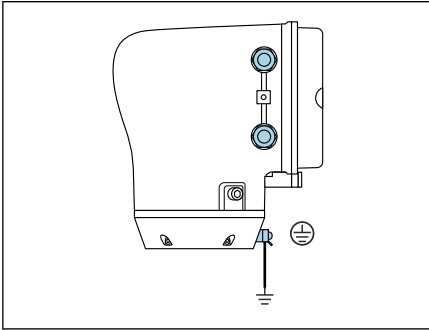

A0045442

1. Ground the device carefully and provide potential equalization.
2. Connect protective earthing to the outer ground terminals.

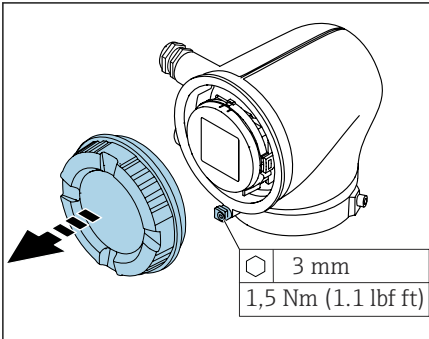

A0041094

3. Loosen the Allen key of the securing clamp.
4. Unscrew the housing cover in the counterclockwise direction.

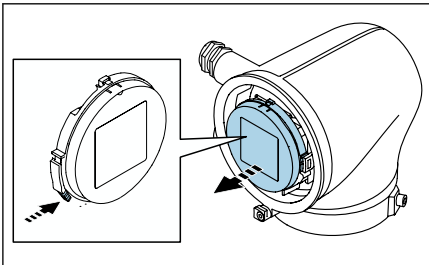

A0041330

5. Press the tab of the display module holder.
6. Remove the display module from the display module holder.

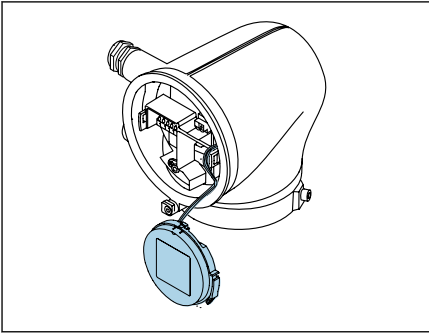

A0041354

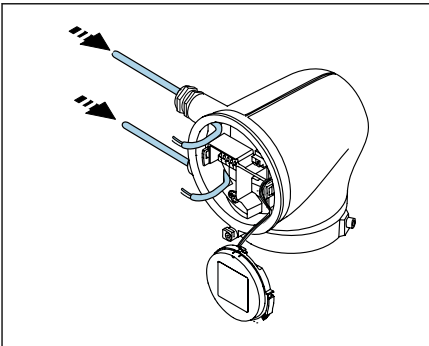

A0041356

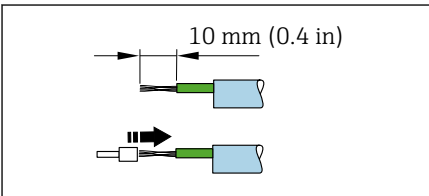

A0041357

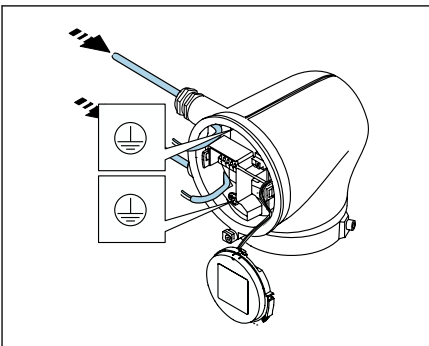

A0041358

- i** The cable must be in the tab for strain relief.
- 7. Let the display module hang down.

- 8. Remove dummy plug if present.

NOTICE

If the sealing ring is missing, the housing is not sealed tight!

Damage to the device.

- ▶ Do not remove the sealing ring from the cable entry.

- 9. Feed the power supply cable and signal cable through the corresponding cable entry.
- 10. Strip the cable and cable ends.
- 11. Fit ferrules over the strands and press in place.

- i** The terminal assignment is documented on an adhesive label.
- 12. Connect the protective ground (PE) to the inner ground terminal.
- 13. Connect the power supply cable and signal cable as per the terminal assignment.
- 14. Connect the cable shields to the inner ground terminal.
- 15. Tighten the cable glands.
- 16. Follow the sequence in the reverse order to reassemble.

5.7 Ensuring potential matching Promag D, P, W

5.7.1 Introduction

Correct potential equalization (equipotential bonding) is a prerequisite for stable and reliable flow measurement. Inadequate or incorrect potential equalization can result in device failure and present a safety hazard.

The following requirements must be observed to ensure correct, trouble-free measurement:

- The principle that the medium, the sensor and the transmitter must be at the same electrical potential applies.
- Take in-company grounding guidelines, materials and the grounding conditions and potential conditions of the pipe into consideration.
- Any necessary potential matching connections must be established by ground cables with a minimum cross-section of 6 mm^2 (0.0093 in^2).
- In the case of remote device versions, the ground terminal in the example always refers to the sensor and not to the transmitter.



Accessories such as ground cables and ground disks can be ordered from Endress +Hauser: see the Operating Instructions for the device.



If a device is intended for use in hazardous areas, pay attention to the information in the Ex documentation (XA).

Abbreviations used

- PE (Protective Earth): potential at the protective earth terminals of the device
- P_P (Potential Pipe): potential of the pipe, measured at the flanges
- P_M (Potential Medium): potential of the medium

5.7.2 Connection examples for standard situations

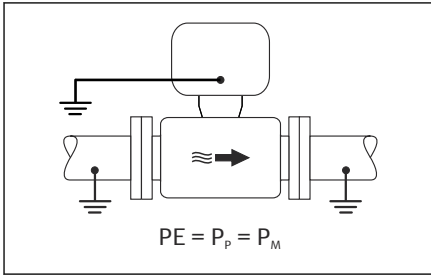

Unlined and grounded metal pipe

- Potential equalization is via the measuring pipe.
- The medium is set to ground potential.

Starting conditions:

- Pipes are correctly grounded on both sides.
 - Pipes are conductive and at the same electrical potential as the medium
- Connect the connection housing of the transmitter or sensor to ground potential by means of the ground terminal provided for this purpose.

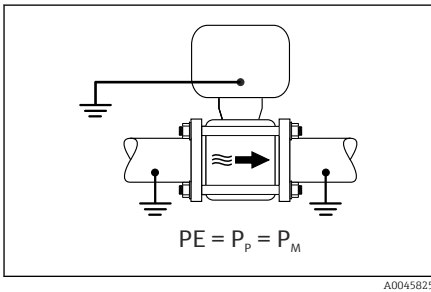

Promag P, W

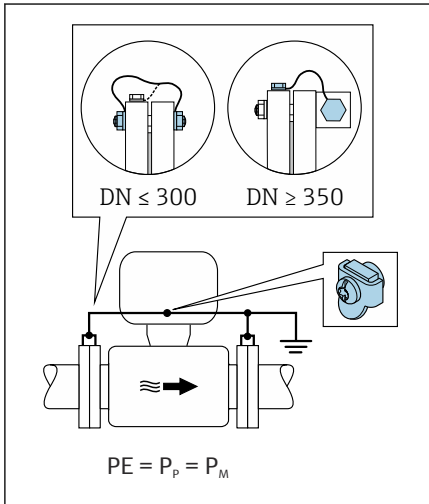

A0042089

Unlined metal pipe

- Potential equalization is via the ground terminal and pipe flanges.
- The medium is set to ground potential.

Starting conditions:

- Pipes are not sufficiently grounded.
 - Pipes are conductive and at the same electrical potential as the medium
1. Connect both sensor flanges to the pipe flange via a ground cable and ground them.
 2. Connect the connection housing of the transmitter or sensor to ground potential by means of the ground terminal provided for this purpose.
 3. If $DN \leq 300$ (12"): mount the ground cable directly on the conductive flange coating of the sensor with the flange screws.
 4. If $DN \geq 350$ (14"): mount the ground cable directly on the metal transport bracket. Observe screw tightening torques: see the Brief Operating Instruction for the sensor.

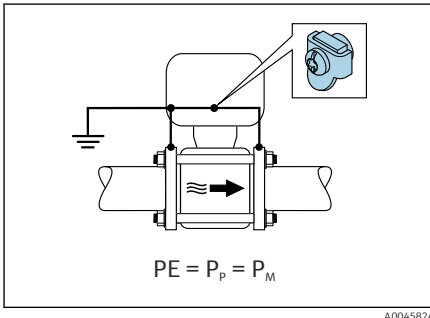
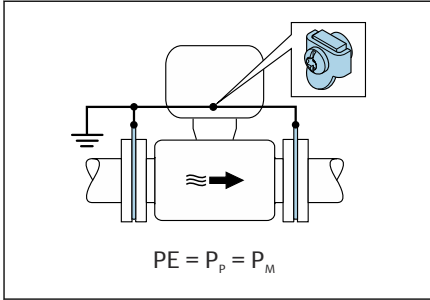

Plastic pipe or pipe with insulating liner

- Promag P, W: Potential matching is via the ground terminal and ground disks.
- Promag D: Potential matching is via the ground terminal and flanges.
- The medium is set to ground potential.

Starting conditions:

- The pipe has an insulating effect.
- Low-impedance medium grounding close to the sensor is not guaranteed.
- Equalizing currents through the medium cannot be ruled out.

1. Promag P, W: Connect the ground disks via the ground cable to the ground terminal of the connection housing of the transmitter or sensor.
2. Promag D: Connect the flanges via the ground cable to the ground terminal of the connection housing of the transmitter or sensor.
3. Connect the connection to ground potential.

5.7.3 Connection example with the potential of medium not equal to protective earth without the "Measurement isolated from ground" option

In these cases, the medium potential can differ from the potential of the device.

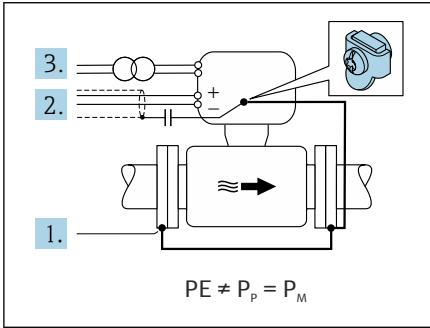

Metal, ungrounded pipe

The sensor and transmitter are installed in a way that provides electrical insulation from PE, e.g. applications for electrolytic processes or systems with cathodic protection.

Starting conditions:

- Unlined metal pipe
 - Pipes with an electrically conductive liner
1. Connect the pipe flanges and transmitter via the ground cable.
 2. Route the shielding of the signal lines via a capacitor (recommended value 1.5µF/50V).
 3. Device connected to power supply such that it is floating in relation to the protective earth (isolation transformer). This measure is not required in the case of 24V DC supply voltage without PE (= SELV power unit).

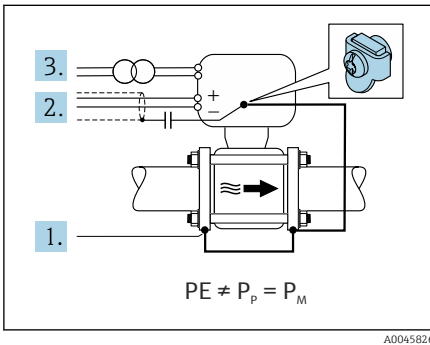

5.7.4 Promag P, W: Connection examples with the potential of medium not equal to protective earth with the "Measurement isolated from ground" option

In these cases, the medium potential can differ from the potential of the device.

Introduction

The "Measurement isolated from ground" option enables the galvanic isolation of the measuring system from the device potential. This minimizes harmful equalizing currents

caused by differences in potential between the medium and the device. The "Measurement isolated from ground" option is optionally available: order code for "Sensor option", option CV

Operating conditions for the use of the "Measurement isolated from ground" option

Device version	Compact version and remote version (length of connecting cable ≤ 10 m)
Differences in voltage between medium potential and device potential	As small as possible, usually in the mV range
Alternating voltage frequencies in the medium or at ground potential (PE)	Below typical power line frequency in the country

i To achieve the specified conductivity measuring accuracy, a conductivity calibration is recommended when the device is installed.

A full pipe adjustment is recommended when the device is installed.

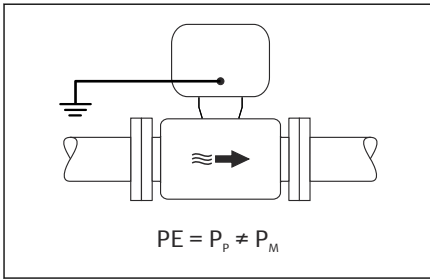

Plastic pipe

Sensor and transmitter are correctly grounded. A difference in potential can occur between the medium and protective earth. Potential equalization between P_M and PE via the reference electrode is minimized with the "Measurement isolated from ground" option.

Starting conditions:

- The pipe has an insulating effect.
 - Equalizing currents through the medium cannot be ruled out.
1. Use the "Measurement isolated from ground" option, while observing the operating conditions for measurement isolated from ground.
 2. Connect the connection housing of the transmitter or sensor to ground potential by means of the ground terminal provided for this purpose.

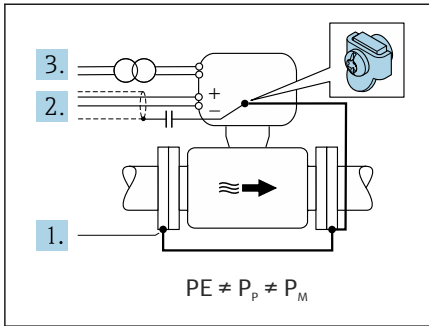

Metal, ungrounded pipe with insulating liner

The sensor and transmitter are installed in a way that provides electrical insulation from PE. The medium and pipe have different potentials. The "Measurement isolated from ground" option minimizes harmful equalizing currents between P_M and P_P via the reference electrode.

Starting conditions:

- Metal pipe with insulating liner
 - Equalizing currents through the medium cannot be ruled out.
1. Connect the pipe flanges and transmitter via the ground cable.
 2. Route the shielding of the signal cables via a capacitor (recommended value $1.5\mu\text{F}/50\text{V}$).
 3. Device connected to power supply such that it is floating in relation to the protective earth (isolation transformer). This measure is not required in the case of 24V DC supply voltage without PE (= SELV power unit).
 4. Use the "Measurement isolated from ground" option, while observing the operating conditions for measurement isolated from ground.

5.8 Ensuring potential equalization Promag H

5.8.1 Metal process connections

Potential equalization is via the metal process connections that are in contact with the medium and mounted directly on the sensor.

5.8.2 Plastic process connections

Note the following when using grounding rings:

- Depending on the option ordered, plastic disks are used instead of grounding rings on some process connections. The plastic disks act as "spacers" and do not have any potential equalization function. They perform a significant sealing function at the sensor and process connection interfaces. In the case of process connections without metal grounding rings, the plastic disks and seals must never be removed. Plastic disks and seals must always be installed.
- Grounding rings can be ordered separately as an accessory from Endress+Hauser. The grounding rings must be compatible with the electrode material, as otherwise there is the danger that the electrodes could be destroyed by electrochemical corrosion.
- Grounding rings, including seals, are installed inside the process connections. This does not affect the installation length.

Connection example for potential equalization with additional grounding ring

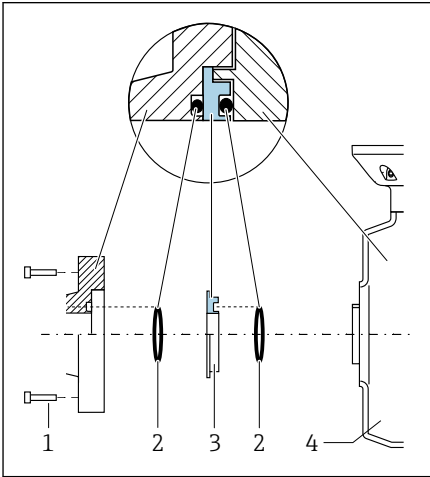

NOTICE

If potential equalization is not provided, this can lead to the electrochemical degradation of the electrodes or affect measuring accuracy!

Damage to the device.

- ▶ Install grounding rings.
- ▶ Provide (establish) potential equalization.

1. Loosen the hexagonal-headed bolts (1).
2. Remove the process connection from the sensor (4).
3. Remove the plastic disk (3), along with the seals (2), from the process connection.
4. Place the first seal (2) into the groove of the process connection.
5. Place the metal grounding ring (3) into the process connection.
6. Place the second seal (2) into the groove of the grounding ring.
7. Observe the maximum screw tightening torques for lubricated threads:
7 Nm (5.2 lbf ft)
8. Mount the process connection on the sensor (4).

Connection example for potential equalization with grounding electrodes

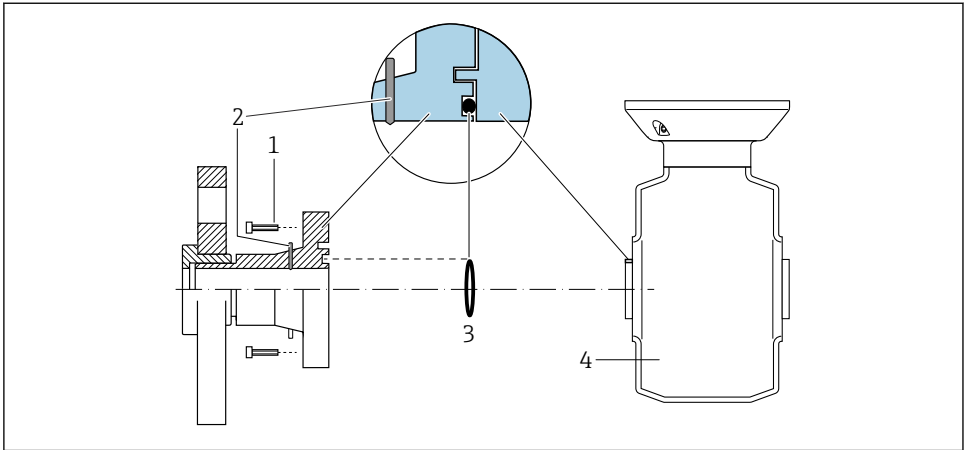

A0028972

- 1 Hexagonal-headed bolts of process connection
- 2 Integrated grounding electrodes
- 3 Seal
- 4 Sensor

5.9 Removing a cable

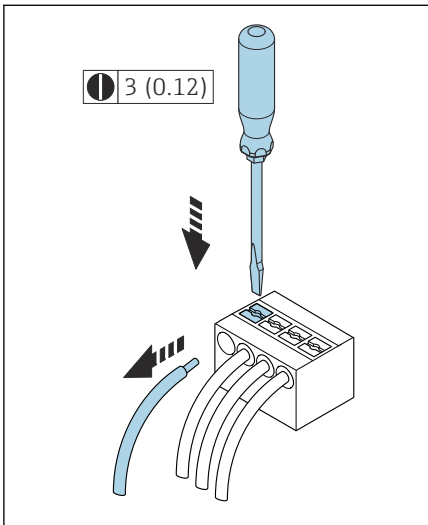

A0044725

1. Use a flat-blade screwdriver to press down on the slot between the two terminal holes and hold.
2. Remove the cable end from the terminal.

4 Engineering unit mm (in)

5.10 Examples for electric terminals

5.10.1 Modbus RS485

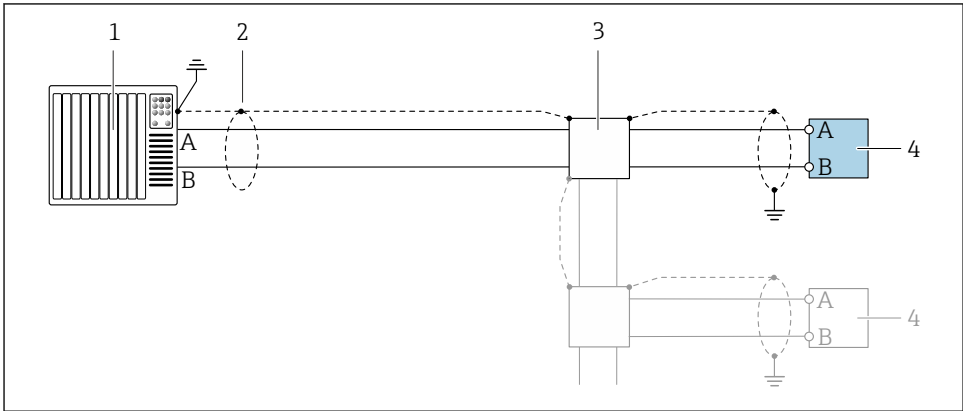

A0028765

5 Connection example for Modbus RS485, non-hazardous area and Zone 2; Class I, Division 2

- 1 Automation system, e.g. PLC
- 2 Cable shield
- 3 Distribution box
- 4 Transmitter

5.10.2 Current output 4 to 20 mA (active)

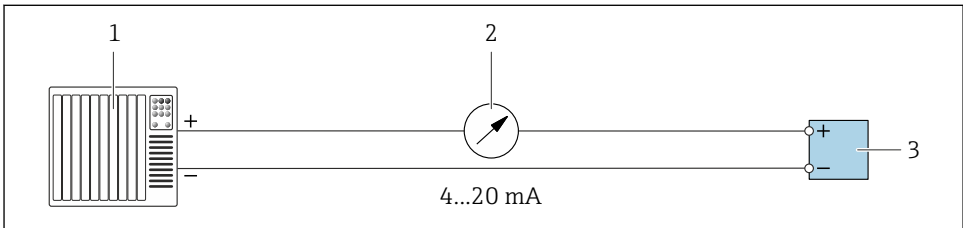

A0028758

- 1 Automation system with current input, e.g. PLC
- 2 Analog display unit: observe max. load.
- 3 Transmitter

5.10.3 Current output 4 to 20 mA (passive)

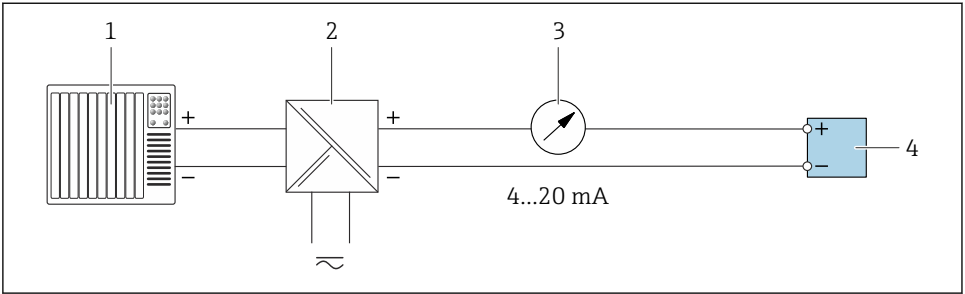

A0028759

- 1 Automation system with current input, e.g. PLC
- 2 Active barrier for supply voltage, e.g. RN221N
- 3 Analog display unit: observe max. load.
- 4 Transmitter

5.11 Post-connection check

Only for remote version:

Is the serial number on the nameplates of the connected sensor and transmitter identical?

Is the potential equalization established correctly?

Is the protective earthing established correctly?

Are the device and cable undamaged (visual check)?

Do the cables meet the requirements?

Is the terminal assignment correct?

Have old and damaged seals been replaced?

Are the seals dry, clean and installed correctly?

Are all the cable glands installed, firmly tightened and leak-tight?

Are dummy plugs inserted in unused cable entries?

Are transportation plugs replaced by dummy plugs?

Are the housing screws and housing cover tightened?

Do the cables loop down before the cable gland ("water trap")?

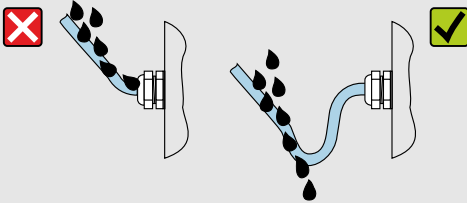

A0042316

Does the supply voltage match the specifications on the transmitter nameplate?

6 Operation

6.1 Overview of the operating options

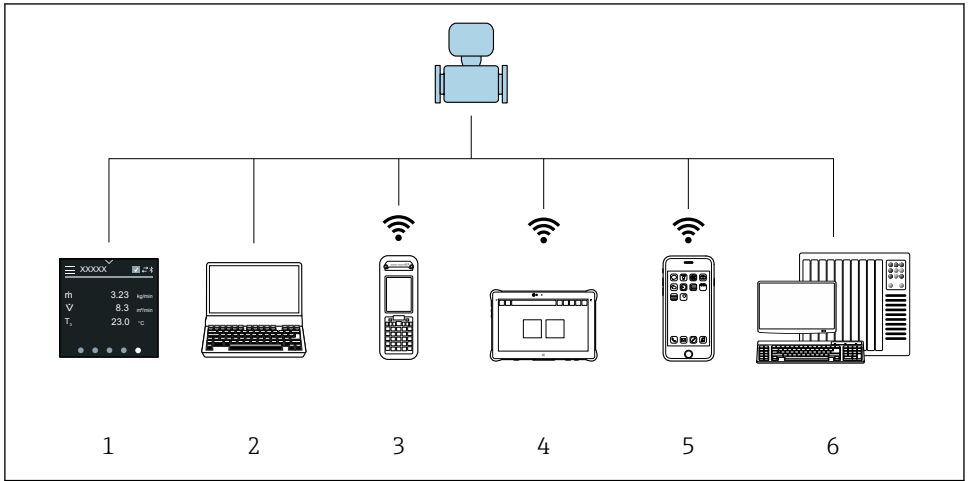

A0044206

- 1 Local operation via touch screen
- 2 Computer with operating tool, e.g. FieldCare, DeviceCare, AMS Device Manager, SIMATIC PDM
- 3 Field Xpert SFX350 or SFX370 via Bluetooth
- 4 Field Xpert SMT70 via Bluetooth
- 5 Tablet or smartphone via Bluetooth
- 6 Automation system, e.g. PLC

6.2 Local operation

6.2.1 Unlocking local operation

Local operation must first be unlocked before the device can be operated via the touch screen. To unlock, draw the pattern "L" on the touch screen.

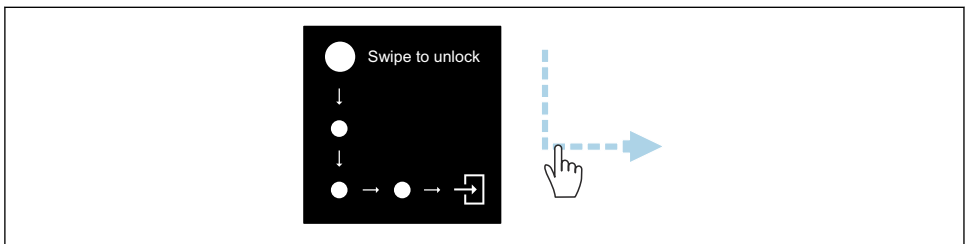

A0044415

6.2.2 Navigation

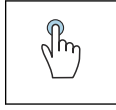

Tap

- Open menus.
- Select items in a list.
- Acknowledge buttons.
- Enter characters.

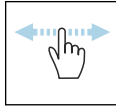

Swipe horizontally

Display next or previous page.

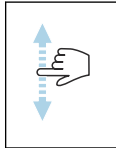



Swipe vertically

Display additional points in a list.

6.2.3 Operational display

During routine operation, the local display shows the operational display screen. The operational display consists of several windows which the user can toggle between.

 The operational display can be customized: see the description of parameters →  44.

Operational display and navigation

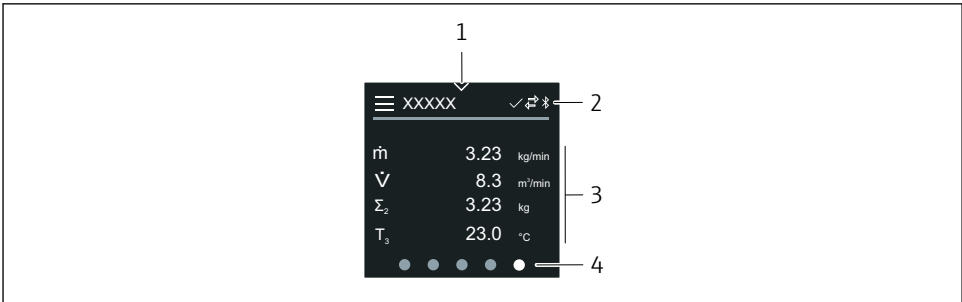

A0042992

- 1 Quick access
- 2 Status symbols, communication symbols and diagnostic symbols
- 3 Measured values
- 4 Rotating page display

Symbols

 Open the main menu.

- ✓ Quick access
- 🔒 Locking status
- 📶 Bluetooth is active.
- ↔ Device communication is enabled.
- ▽ Status signal: function check
- 🔧 Status signal: maintenance required
- ⚠ Status signal: out of specification
- ⊗ Status signal: failure
- ☑ Status signal: diagnostics active.

6.2.4 Quick access

The Quick access menu contains a selection of specific device functions.

 Quick access is indicated by a triangle at the top of the local display in the middle.

Quick access and navigation

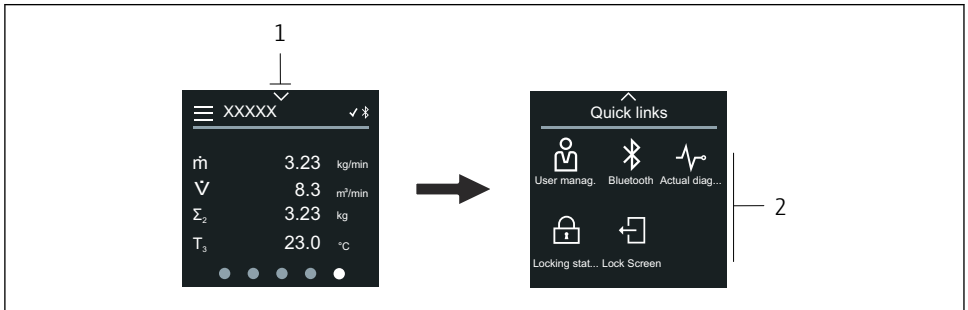

A0044208

- 1 Quick access
- 2 Quick access with specific device functions

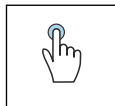



Tap

- Back to operational display.
- Open specific device functions.

Symbols

When a symbol is tapped, the local display shows the menu with the corresponding specific device functions.

- 📶 Enable or disable Bluetooth.

-  Enter access code.
-  Write protection is enabled.
-  Back to operational display.

6.2.5 Main menu

The main menu contains all the menus required for the commissioning, configuration and operation of the device.

Main menu and navigation

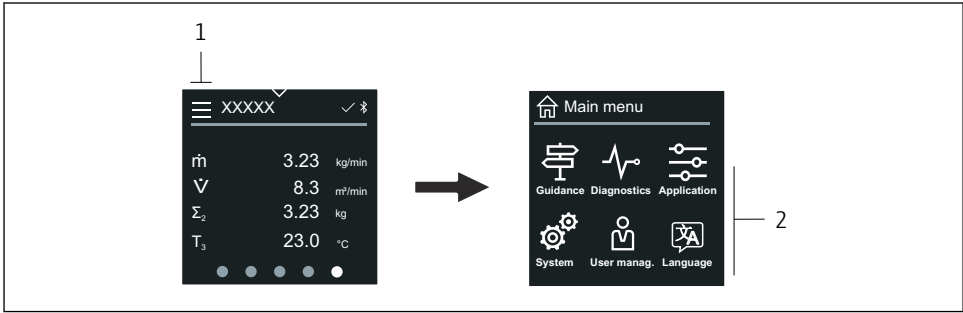

A0044213



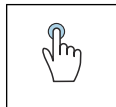



- 1 Open the main menu.
- 2 Open menus for the specific device functions.



Tap

- Back to operational display.
- Open menus.

Symbols

-  Back to operational display.
-  **Guidance** menu
Configuration of the device
-  **Diagnostics** menu
Troubleshooting and control of device behavior
-  **Application** menu
Application-specific adjustments
-  **System** menu
Device management and user administration
-  Set display language.

Submenus and navigation

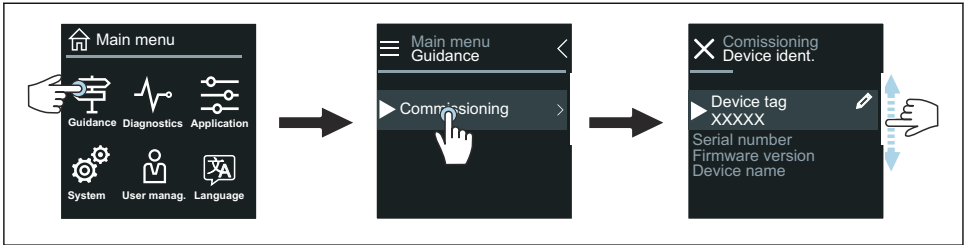

A0044219

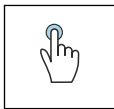

Tap

- Open the main menu.
- Open submenus or parameters.
- Select options.
- Skip items in list.

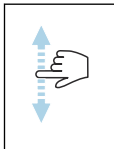

Swipe vertically

Select items in a list on a step-by-step basis.

Symbols

- < Return to previous menu.
- ⬇ Skip to bottom of list.
- ⬆ Skip to top of list.

6.2.6 Diagnostic information

Diagnostic information displays additional instructions or background information for diagnostic events.

Opening the diagnostic message



The diagnostic behavior is indicated on the top right of the local display by a diagnostics symbol. Tap the symbol or the "Help" button to open the diagnostic message.

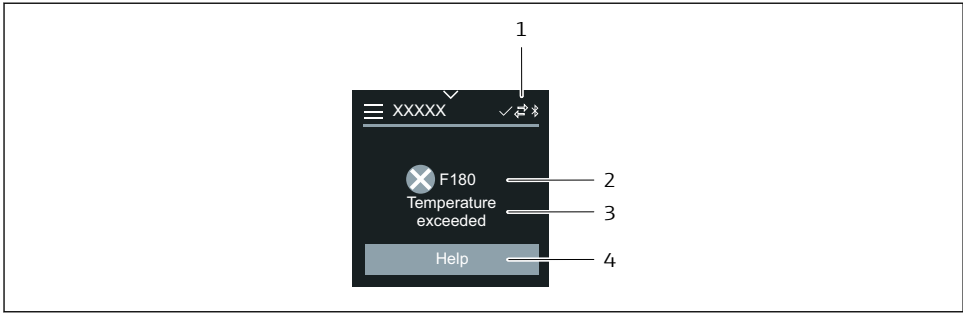

A0043008

- 1 Device status
- 2 Diagnostic behavior with diagnostic code
- 3 Short text
- 4 Open the troubleshooting measures.

6.2.7 Editing view

Editor and navigation

The text editor is used to enter characters.

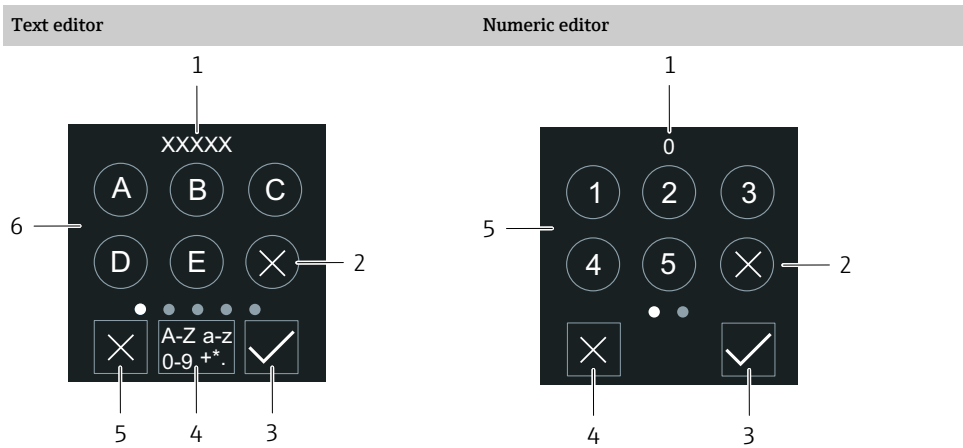

A0043020

A0043023

- 1 Entry display area
- 2 Delete character.
- 3 Confirm your entry.
- 4 Switch input field.
- 5 Cancel editor.
- 6 Input field

- 1 Entry display area
- 2 Delete character.
- 3 Confirm your entry.
- 4 Cancel editor.
- 5 Input field

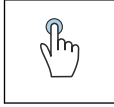
**Tap**

- Enter characters.
- Select next character set.

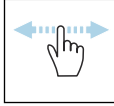
**Swipe horizontally**

Display next or previous page.

Input field

Upper case

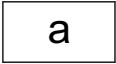

Lower case



Numbers

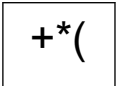

Special characters

6.2.8 Date

The device has a real-time clock for all log functions. The time can be configured here.

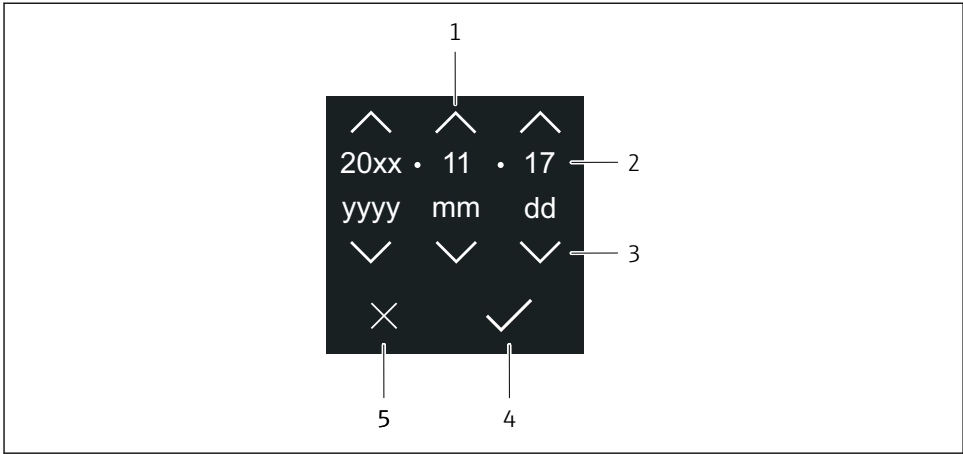

A0043043

- 1 Increase date by 1.
- 2 Actual value
- 3 Decrease date by 1.
- 4 Confirm settings.
- 5 Cancel editor.

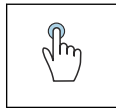



Tap

- Make settings.
- Confirm settings.
- Cancel editor.

6.3 SmartBlue App

The device has a Bluetooth interface and can be operated and configured using the SmartBlue App. The SmartBlue App must be downloaded onto a terminal device for this purpose. Any terminal device can be used.

- The range is 20 m (65.6 ft) under reference conditions.
- Incorrect operation by unauthorized persons is prevented by means of encrypted communication and password encryption.
- Bluetooth can be disabled.

Download	<p>Endress+Hauser SmartBlue App:</p> <ul style="list-style-type: none"> ▪ Google Playstore (Android) ▪ iTunes Apple Shop (iOS devices) <div style="display: flex; justify-content: space-around; align-items: center;"> <div style="text-align: center;">  </div> <div style="text-align: center;">  </div> </div> <div style="display: flex; justify-content: space-around; align-items: center; margin-top: 10px;"> <div style="text-align: center;">  </div> </div>
Supported functions	<ul style="list-style-type: none"> ▪ Configuration of the device ▪ Access to measured values, device status and diagnostic information

7 System integration





For detailed information on system integration, see the Operating Instructions for the device.

- Overview of device description files:
 - Current version data for the device
 - Operating tools
- Compatibility with previous model
- Modbus RS485 information
 - Function codes
 - Response time
 - Modbus data map

8 Commissioning

8.1 Post-installation check and post-connection check

Before commissioning the device, make sure that the post-installation and post-connection checks have been performed:

- Post-installation check →  12
- Post-connection check →  40

8.2 Switching on the device

- ▶ Switch on the supply voltage for the device.
 - ↳ The local display switches from the start screen to the operational display.

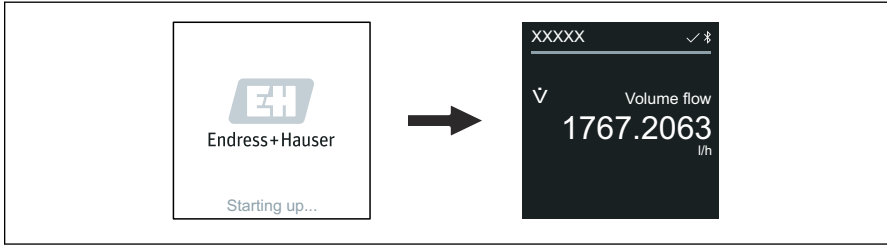

A0042938

i If device startup is not successful, the device displays an error message to this effect .

8.3 Commissioning the device

8.3.1 Local operation

 Detailed information on local operation:

1. Via the "Menu" symbol, open the main menu.

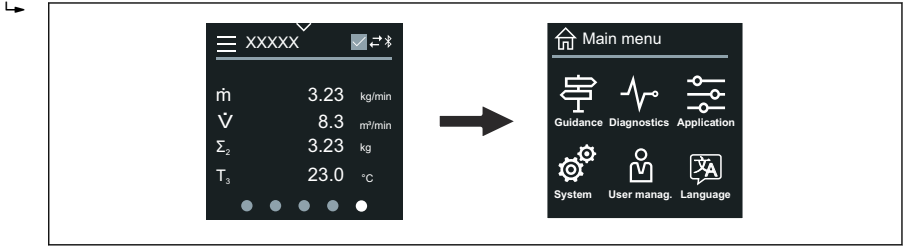

2. Via the "Language" symbol, select the desired language.

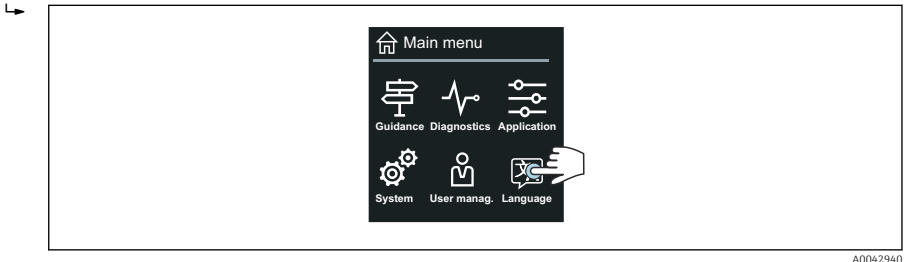

3. Via the "Guidance" symbol, open the **Commissioning** wizard.

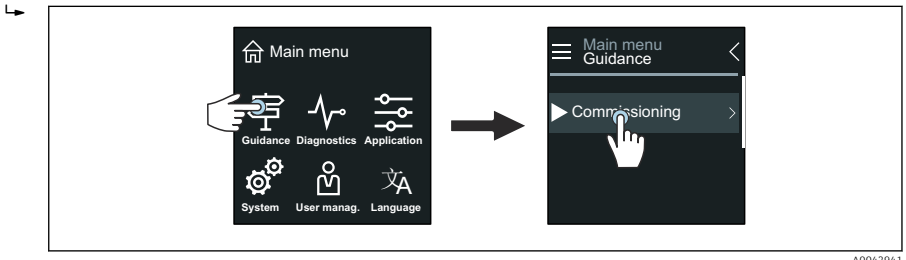

4. Start the **Commissioning** wizard.

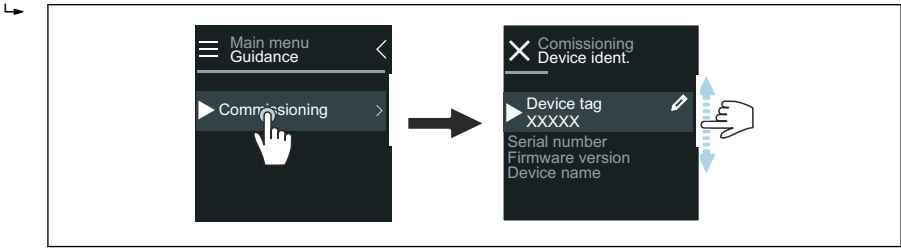

A0043018

5. Follow the instructions on the local display.

- ↳ The **Commissioning** wizard goes through all the device parameters that are necessary to commission the device.

 For detailed information, see the "Description of Device Parameters" document pertaining to the device.

8.3.2 SmartBlue App

 Information on the SmartBlue App →  48.

Connecting the SmartBlue App to the device

1. Enable Bluetooth on the mobile handheld terminal, tablet or smartphone.
2. Start the SmartBlue App.
 - ↳ A Live List shows all the devices available.
3. Select the desired device.
 - ↳ The SmartBlue App shows the device login.
4. Under user name, enter **admin**.
5. Under password, enter the device's serial number. See nameplate for serial number.
6. Confirm your entries.
 - ↳ The SmartBlue App connects to the device and displays the main menu.

Opening the "Commissioning" wizard

1. Via the **Guidance** menu, open the **Commissioning** wizard.
2. Follow the instructions on the local display.
 - ↳ The **Commissioning** wizard goes through all the device parameters that are necessary to commission the device.

8.4 Protecting settings from unauthorized access

8.4.1 Write protection switch

Write access to the entire operating menu can be locked via the write protection switch. The values of the parameters cannot be changed. Write protection is disabled when the device leaves the factory.

Write protection is enabled with the write protection switch on the back of the display module.

 For detailed information on protecting settings against unauthorized access, see the Operating Instructions for the device.

9 Diagnostics and troubleshooting

9.1 Diagnostic information on local display

9.1.1 Diagnostic message

The local display alternates between displaying faults as a diagnostic message and displaying the operational display screen.

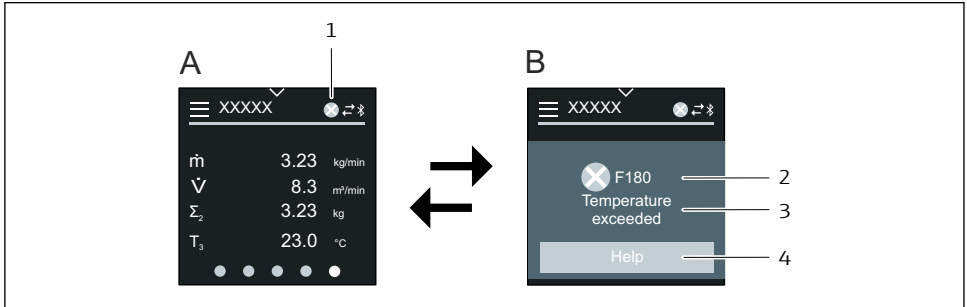

A0042937

- A Operational display in alarm condition
- B Diagnostic message
- 1 Diagnostic behavior
- 2 Status signal
- 3 Diagnostic behavior with diagnostic code
- 4 Short text
- 5 Open information on remedial measures.

 For detailed information on diagnostic information, see the Operating Instructions for the device.



71526976

www.addresses.endress.com
