

Special Documentation

VICOTEC410

Supplement to Electrical Connections of Control Unit
RCU410

Described product

Product name: VICOTEC410

Manufacturer

Endress+Hauser SICK GmbH+Co. KG
Bergener Ring 27
01458 Ottendorf-Okrilla
Germany

Legal information

This work is protected by copyright. Any rights derived from the copyright shall be reserved for Endress+Hauser SICK GmbH+Co. KG. Reproduction of this document or parts of this document is only permissible within the limits of the legal determination of Copyright Law. Any modification, shortening or translation of this document is prohibited without the express written permission of Endress+Hauser SICK GmbH+Co. KG. The trademarks stated in this document are the property of their respective owner.

© Endress+Hauser SICK GmbH+Co. KG. All rights reserved.

Original document

This document is an original document of Endress+Hauser SICK GmbH+Co. KG.



1	About this document.....	4
1.1	Additional documentation / information.....	4
2	For your safety.....	4
2.1	Main operating information	4
3	Supplement to Operating Instructions	4
3.1	Supplement to connection cables.....	4
3.2	Supplement to electrical connections of control unit	5
3.3	Supplement to connection cable between sensor and RCU410	7

1 About this document

1.1 Additional documentation / information

This document supplements the Operating Instructions of in-situ analyzers VICOTEC410 and may only be used in connection with their applicable Operating Instructions.

It supplements or replaces the contents of the Operating Instructions listed below with all the information and instructions required for the electrical connections, particularly those for the power supply of control unit RCU.

All other contents of these Operating Instructions remains valid.

Please follow the respective Operating Instructions provided:

- VICOTEC410: 8029841

2 For your safety

2.1 Main operating information

Observe the following safety precautions:



NOTICE: This document is only valid in combination with the VICOTEC410 Operating Instructions

- ▶ Observe all operating and safety information of the VICOTEC410 Operating Instructions!
-

3 Supplement to Operating Instructions

3.1 Supplement to connection cables



NOTICE: Changed specification of signal cables

- ▶ Shielded cables must be used for customer signal cables to the system peripherals.
-

3.2 Supplement to electrical connections of control unit



CAUTION: Changed connection of power cable

- ▶ Pay attention to changed installation instructions!

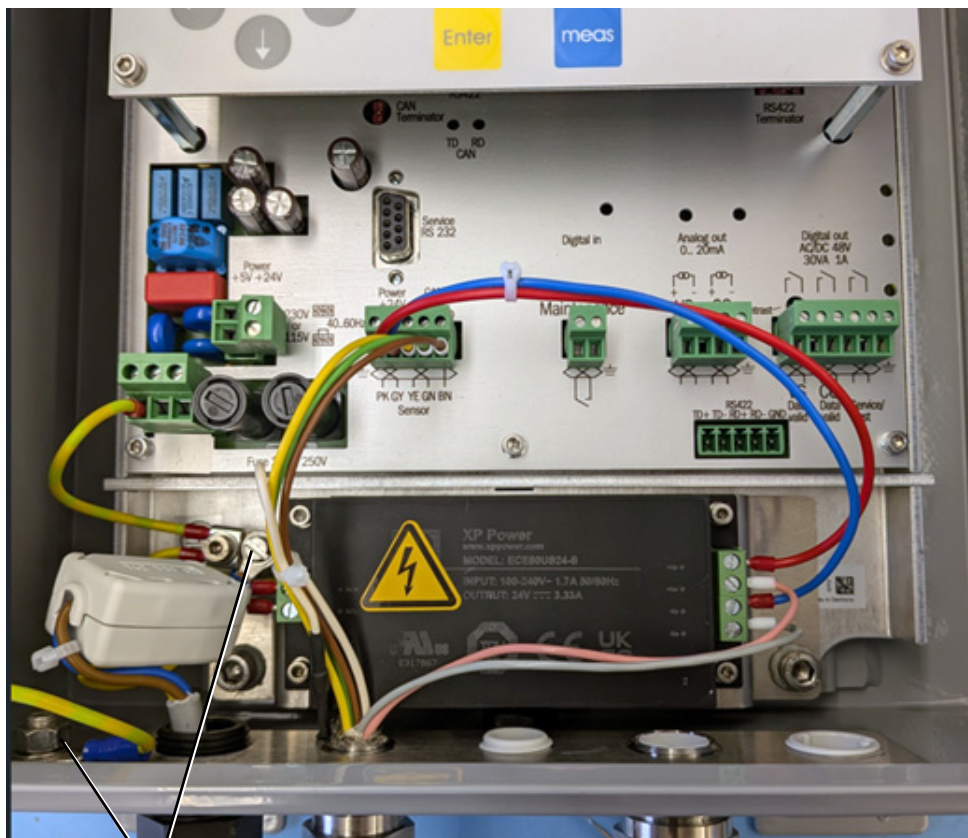

①

① Connection options for grounding conductor

Fig. 1: Control unit RCU: Overview of connections for power supply

Procedure

- 1 Connect the grounding conductor using a cable lug.
- 2 Strip a generous length of insulation (approx. 9 cm) from the RCU power supply cable.



Fig. 2: Power supply connection

- 3 Connect the N and L conductors according to the labeling on the power supply unit.

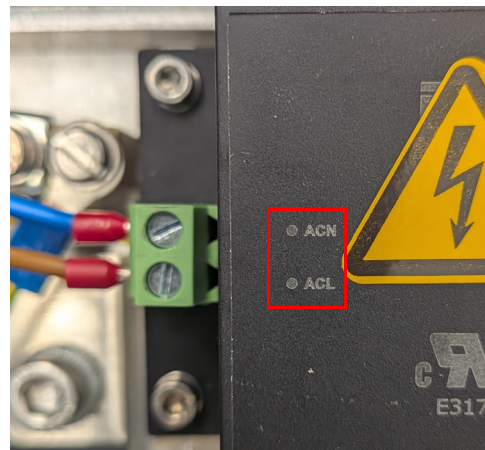

Fig. 3: Power supply connection

- 4 Take the two cable ties and the snap-on ferrite from the bag delivered with the RCU.



Fig. 4: Accessories for RCU control unit

- 5 Place the first cable tie 5 mm behind the ferrules on the N/L conductor and tighten it.

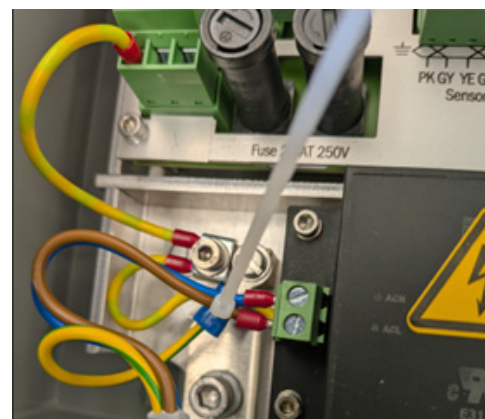

Fig. 5: Cable tie for N/L conductors (power supply unit)

- 6 Place the snap-on ferrite around the N/L conductor (not the PE) and close it.
- 7 Attach the second cable tie behind the ferrite, tighten and trim the second cable tie.



Fig. 6: Snap-on ferrite and second cable tie

3.3 Supplement to connection cable between sensor and RCU410



NOTICE: Changed connection for sensor and RCU

► Changed connection of cables W-S2 and W-C2a to terminal X1 of RCU410

The 24 V and GND wires (pink (24 V) and (gray (GND))) may no longer be connected to terminal X1 but instead directly to the output of the power supply unit.

Cable W-S2

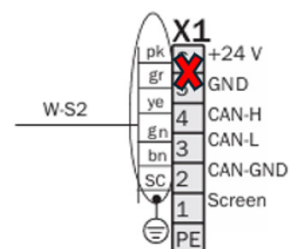

Cable W-C2

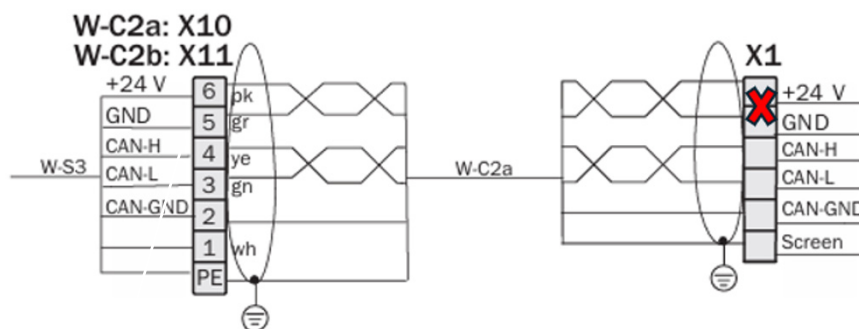

Fig. 7: Changed connection of cables W-S2 and W-C2

- 1 Insert the prepared cable through the cable gland and attach the cable shield.



Fig. 8: Cable gland

- 2 Connect the wires of the CAN connection to the sensor to terminal X1 as shown in Fig. 9.



Fig. 9: Connect the CAN bus

- 3 Connect the 24 V power supply of the sensor directly to the power supply unit. Pink +Vo, gray -Vo.



Fig. 10: Connect 24 V

8031831/AE00/V1-0/2026-03

www.addresses.endress.com
