

Technical Information

Dosimass

Coriolis flowmeter



Mass flowmeter with hygienic design, highest repeatability and a compact transmitter

Application

- Measuring principle operates independently of physical fluid properties such as viscosity or density
- Measurement of liquids with the most diverse properties for demanding batching and dosing applications

Device properties

- Wetted materials CIP, SIP cleanable
- Hygienic approvals 3-A and EHEDG available
- Fullfilling global Food Contact Materials, EU, US, CN
- Robust, compact transmitter housing
- Pulse/frequency/switch output, IO-Link, Modbus RS485
- Excellent and easily cleanable transmitter

Your benefits





- High process safety – highest measuring accuracy for different media in shortest filling time
- Fewer process measuring points – multivariable measurement (flow, density, temperature)
- Space-saving installation – no in-/outlet run needs
- Versatile and time-saving wiring – plug connector
- Fast commissioning – pre-configured devices
- Automatic recovery of data for servicing

Table of contents









About this document	3	Vibration-resistance and shock-resistance	29
Electrical symbols	3	Electromagnetic compatibility (EMC)	30
Symbols for certain types of information	3	Overvoltage protection	30
Symbols in graphics	3		
Function and system design	4	Process	30
Measuring principle	4	Medium temperature range	30
Measuring system	5	Medium pressure range	30
Equipment architecture	6	Medium density	30
Dependability	7	Pressure-temperature ratings	30
		Sensor housing	32
		Flow limit	32
		Pressure loss	32
		Heating	32
		Vibrations	32
Input	7		
Measured variable	7	Mechanical construction	33
Measuring range	7	Dimensions in SI units	33
Operable flow range	8	Dimensions in US units	38
Input signal	8	Weight	42
		Materials	42
		Process connections	43
		Surface roughness	43
Output	9		
Output signal	9	Operability	44
Signal on alarm	11	Languages	44
Low flow cut off	11	Local operation	44
Galvanic isolation	12	IO-Link	44
Protocol-specific data	12	Remote operation	44
Power supply	13	Certificates and approvals	45
Terminal assignment	13	CE mark	45
Available device plugs	13	UKCA marking	45
Supply voltage	18	RCM marking	45
Power consumption	18	cULus listed	45
Current consumption	18	Ex approval	45
Power supply failure	18	Hygienic compatibility	46
Electrical connection	18	Pharmaceutical compatibility	46
Ensuring	19	Pressure Equipment Directive	46
Cable specification	19	External standards and guidelines	47
		Additional certification	47
Performance characteristics	20	Ordering information	47
Reference operating conditions	20	Accessories	47
Maximum measurement error	21	Device-specific accessories	48
Repeatability	22	Communication-specific accessories	48
Response time	22	Service-specific accessories	48
Influence of ambient temperature	22		
Influence of medium temperature	22	Documentation	48
Influence of medium pressure	22	Standard documentation	48
Design fundamentals	22	Supplementary device-dependent documentation	49
Mounting	23	Registered trademarks	49
Installation point	23		
Orientation	24		
Inlet and outlet runs	26		
Special mounting instructions	26		
Environment	29		
Ambient temperature range	29		
Storage temperature	29		
Degree of protection	29		
Relative humidity	29		
Operating altitude	29		

About this document





Electrical symbols

Symbol	Meaning
	Direct current
	Alternating current
	Direct current and alternating current
	Ground connection A grounded terminal which, as far as the operator is concerned, is grounded via a grounding system.
	Protective earth (PE) Ground terminals that must be connected to ground prior to establishing any other connections. The ground terminals are located on the interior and exterior of the device: <ul style="list-style-type: none"> ■ Interior ground terminal: protective earth is connected to the mains supply. ■ Exterior ground terminal: device is connected to the plant grounding system.

Symbols for certain types of information

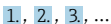
Symbol	Meaning
	Permitted Procedures, processes or actions that are permitted.
	Preferred Procedures, processes or actions that are preferred.
	Forbidden Procedures, processes or actions that are forbidden.
	Tip Indicates additional information.
	Reference to documentation
	Reference to page
	Reference to graphic
	Visual inspection

Symbols in graphics

Symbol	Meaning
1, 2, 3, ...	Item numbers
	Series of steps
A, B, C, ...	Views
A-A, B-B, C-C, ...	Sections
	Hazardous area
	Safe area (non-hazardous area)
	Flow direction

Function and system design

Measuring principle

The measuring principle is based on the controlled generation of Coriolis forces. These forces are always present in a system when both translational and rotational movements are superimposed.

$$F_c = 2 \cdot \Delta m (v \cdot \omega)$$

F_c = Coriolis force

Δm = moving mass

ω = rotational velocity

v = radial velocity in rotating or oscillating system

The amplitude of the Coriolis force depends on the moving mass Δm , its velocity v in the system and thus on the mass flow. Instead of a constant rotational velocity ω , the sensor uses oscillation.

Dosimass DN 1 to 4 ($\frac{1}{24}$ to $\frac{1}{8}$ ") measuring principle

In the sensor, an oscillation is produced in the measuring tube. The Coriolis forces produced at the measuring tube cause a phase shift in the tube oscillations (see illustration):

- If there is zero flow (i.e. when the fluid stands still), the oscillation measured at points A and B has the same phase (no phase shift) (1).
- Mass flow causes deceleration of the oscillation at the inlet of the tubes (2) and acceleration at the outlet (3).

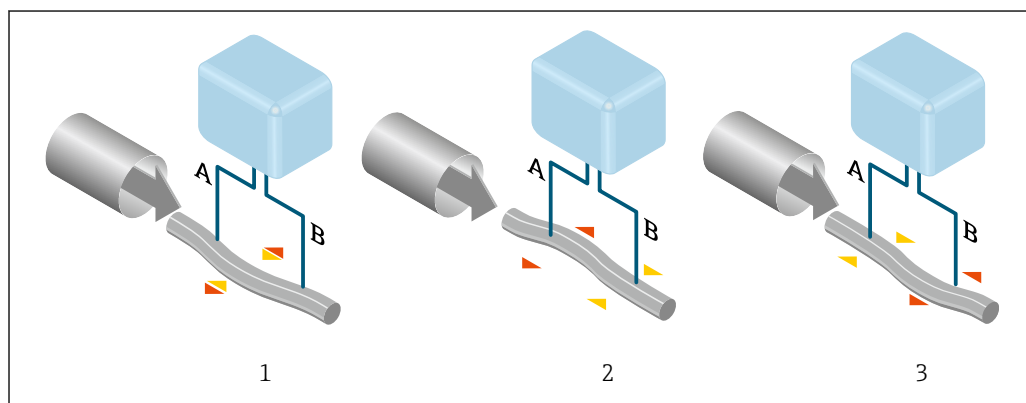

1 Dosimass DN 1 to 4 ($\frac{1}{24}$ to $\frac{1}{8}$ ") measuring principle

The phase shift (A-B) increases with increasing mass flow. Electrodynamic sensors register the tube oscillations at the inlet and outlet. System balance is created by exciting an eccentrically arranged swinging mass to antiphase oscillation. The measuring principle operates independently of temperature, pressure, viscosity, conductivity and flow profile.

Dosimass DN 8 to 40 ($\frac{3}{8}$ to 1 $\frac{1}{2}$ ") measuring principle

In the sensor, two parallel measuring tubes containing flowing fluid oscillate in antiphase, acting like a tuning fork. The Coriolis forces produced at the measuring tubes cause a phase shift in the tube oscillations (see illustration):

- At zero flow (when the fluid is at a standstill) the two tubes oscillate in phase (1).
- Mass flow causes deceleration of the oscillation at the inlet of the tubes (2) and acceleration at the outlet (3).

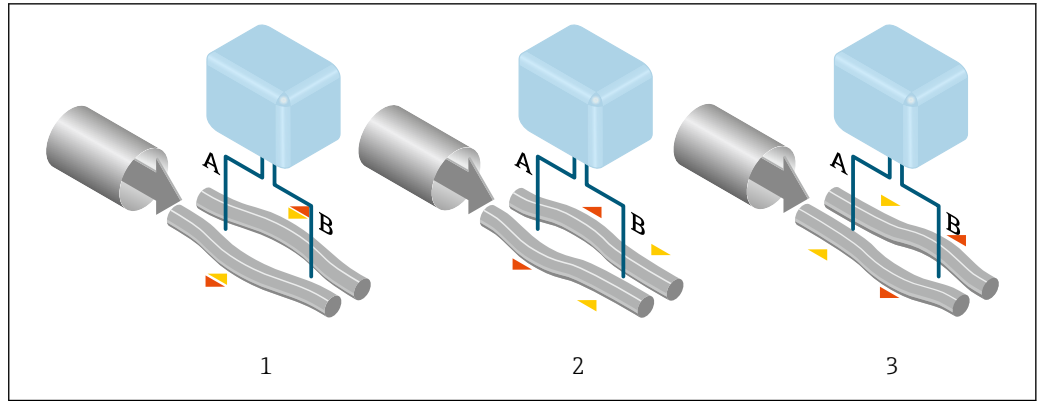

2 Dosimass DN 8 to 40 (3/8 to 1 1/2") measuring principle

The phase shift (A-B) increases with increasing mass flow. Electrodynamic sensors register the tube oscillations at the inlet and outlet. System balance is ensured by the antiphase oscillation of the two measuring tubes. The measuring principle operates independently of temperature, pressure, viscosity, conductivity and flow profile.

Density measurement

The measuring tube is continuously excited at its resonance frequency. A change in the mass and thus the density of the oscillating system (comprising measuring tube and fluid) results in a corresponding, automatic adjustment in the oscillation frequency. The resonance frequency is thus a function of the medium density. The microprocessor utilizes this relationship to obtain a density signal.

Temperature measurement

The temperature of the measuring tube is determined in order to calculate the compensation factor due to temperature effects. This signal corresponds to the process temperature and is also available as an output signal.

Measuring system

The device consists of a transmitter and a sensor.

Dosimass DN 1 to 4 (1/24 to 1/8")

<p>Dosimass</p> <p style="text-align: right; font-size: small;">A0053326</p>	<p>Transmitter</p> <ul style="list-style-type: none"> ▪ Materials: <ul style="list-style-type: none"> ▪ Transmitter housing: stainless steel, 1.4409 (CF3M) ▪ Housing seal: HNBR ▪ Configuration: <ul style="list-style-type: none"> ▪ Via operating tools (e.g. FieldCare) <p>Sensor</p> <ul style="list-style-type: none"> ▪ Range of nominal diameter: DN 1 (1/24"), 2 (1/12"), 4 (1/8") ▪ Materials: <ul style="list-style-type: none"> ▪ Sensor housing: stainless steel, 1.4404 (316/316L) ▪ Measuring tube: stainless steel, 1.4335 (316/316L) ▪ Process connections: stainless steel, 1.4435 (316L)
---	--

Dosimass DN 8 to 40 (3/8 to 1 1/2")

<p>Dosimass</p> <p style="text-align: right; font-size: small;">A0052373</p>	<p>Transmitter</p> <ul style="list-style-type: none"> ▪ Materials: <ul style="list-style-type: none"> ▪ Transmitter housing: stainless steel, 1.4409 (CF3M) ▪ Housing seal: HNBR ▪ Configuration: <ul style="list-style-type: none"> ▪ Via operating tools (e.g. FieldCare) <p>Sensor</p> <ul style="list-style-type: none"> ▪ Range of nominal diameter: DN 8 (3/8"), 15 (1/2"), 25 (1"), 40 (1 1/2") ▪ Materials: <ul style="list-style-type: none"> ▪ Sensor housing: stainless steel, 1.4301 (304) ▪ Measuring tube: stainless steel, 1.4539 (904L) ▪ Process connections: stainless steel, 1.4404 (316/316L)
---	--

Equipment architecture

Device version: Two pulse/frequency/switch outputs

i The device version has two pulse/frequency/switch outputs → 13.

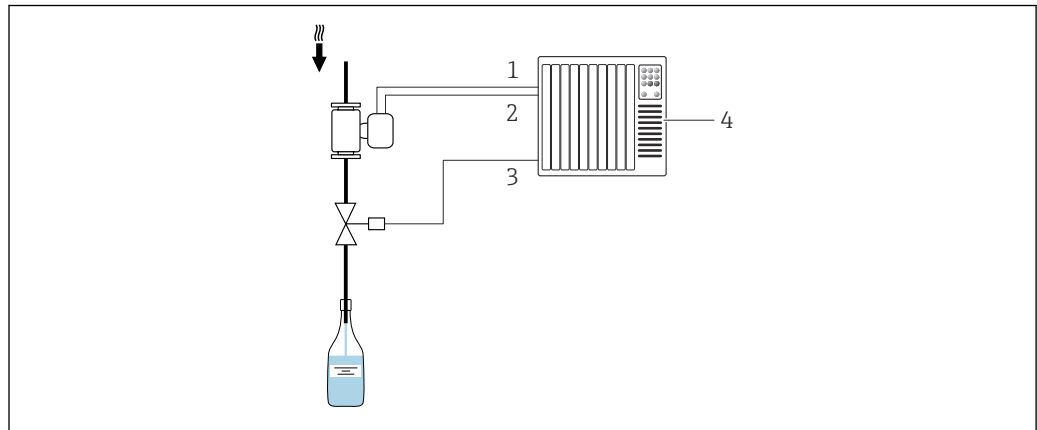

A0027057

3 Options for integration into a system for batching processes

- 1 Pulse/frequency/switch output 1
- 2 Pulse/frequency/switch output 2
- 3 Control of valve (by automation system)
- 4 Control system (e.g. PLC)

Device version: IO-Link, a pulse/frequency/switch output

i The device version with IO-Link has a pulse/frequency/switch output → 13.

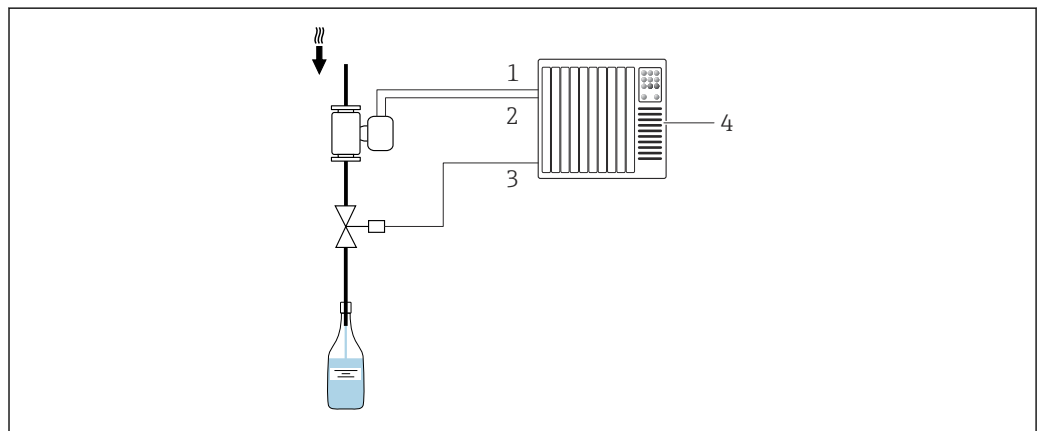

A0027057

4 Options for integration into a system for batching processes

- 1 Pulse/frequency/switch output
- 2 IO-Link
- 3 Control of valve (by automation system)
- 4 Control system (e.g. PLC)

Device version: Modbus RS485, two switch outputs (batch), a status output and a status input

i Device versions with MODBUS RS485 have two switch outputs (batch) for valve control for the regulation of batching processes → 13.

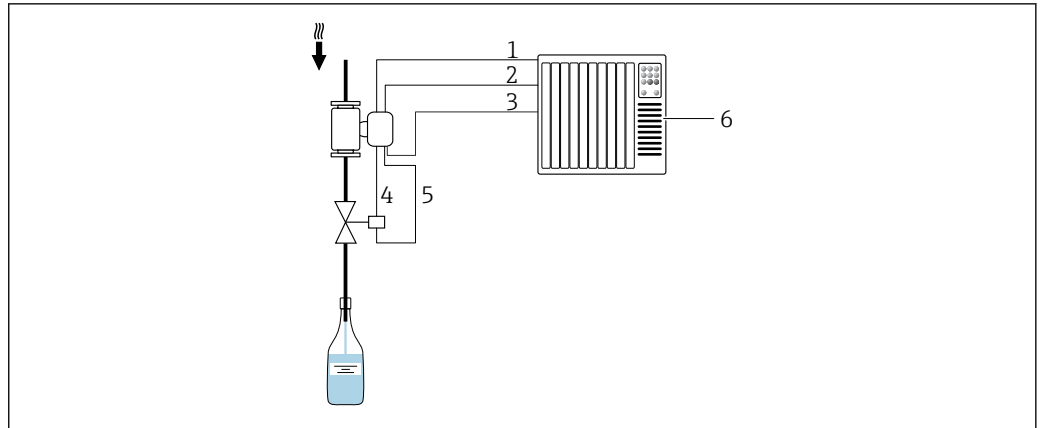

5 Options for integration into a system for batching processes

- 1 MODBUS RS485: Measured value (to the automation system)
- 2 Status output/status input
- 3 Status input: Control of batching process (by the automation system)
- 4 Switch output (batch): Valve activation, level 1
- 5 Switch output (batch): Valve activation, level 2
- 6 Control system (e.g. PLC)

Dependability

IT security

The manufacturer warranty is valid only if the product is installed and used as described in the Operating Instructions. The product is equipped with security mechanisms to protect it against any inadvertent changes to the settings.

IT security measures, which provide additional protection for the product and associated data transfer, must be implemented by the operators themselves in line with their security standards.

Input

Measured variable

Direct measured variables

- Mass flow
- Density
- Temperature

Calculated measured variables

Volume flow



Measuring range

Flow values in SI units



DN [mm]	Measuring range full scale values $\dot{m}_{\min(F)}$ to $\dot{m}_{\max(F)}$ [kg/h]
1	0 to 20
2	0 to 100
4	0 to 450
8	0 to 2 000
15	0 to 6 500
25	0 to 18 000
40	0 to 45 000

Flow values in US units

DN [in]	Measuring range full scale values $\dot{m}_{\min(F)}$ to $\dot{m}_{\max(F)}$ [lb/min]
1/24	0 to 0.735
1/12	0 to 3.675
1/8	0 to 16.54
3/8	0 to 73.50
1/2	0 to 238.9
1	0 to 661.5
1 1/2	0 to 1654

 To calculate the measuring range, use the *Applicator* →  48 sizing tool

Recommended measuring range

 Flow limit →  32

Operable flow range

Over 1000 : 1.

Flow rates above the preset full scale value do not override the electronics unit, with the result that the totalizer values are registered correctly.

Input signal

 Available only for device versions using the Modbus RS485 communication method →  13.

 The batching process is controlled by the automation system via the status input or via the fieldbus interface (Modbus) of the device.

Status input via connection A/B

Maximum input values	<ul style="list-style-type: none"> ▪ DC -3 to 30 V ▪ 5 mA
Response time	Configurable: 10 to 200 ms
Input signal level	<ul style="list-style-type: none"> ▪ Low signal: DC -3 to 5 V ▪ High signal: DC 15 to 30 V
Assignable functions	<ul style="list-style-type: none"> ▪ Off ▪ Start batching process ▪ Start and stop batching process ▪ Reset totalizer 1 to 3 separately ▪ Reset all totalizers ▪ Flow override

Status output via connection A/B

Maximum input values	<ul style="list-style-type: none"> ▪ DC 30 V ▪ 6 mA
Response time	Configurable: 10 to 200 ms
Input signal level	<ul style="list-style-type: none"> ▪ Low signal: DC 0 to 1.5 V ▪ High signal: DC 10 to 30 V
Assignable functions	<ul style="list-style-type: none"> ▪ Off ▪ Start batching process ▪ Start and stop batching process ▪ Reset totalizer 1 to 3 separately ▪ Reset all totalizers ▪ Flow override

Output

Output signal

Pulse/frequency/switch output

Function	<p>Can be set to:</p> <ul style="list-style-type: none"> ▪ Pulse Quantity-proportional pulse with pulse width to be configured. ▪ Automatic pulse Quantity-proportional pulse with on/off ratio of 1:1 ▪ Frequency Flow-proportional frequency output with 1:1 on/off ratio ▪ Switch Contact for displaying a status
Version	<ul style="list-style-type: none"> ▪ Option AA: 2 pulse/frequency/switch outputs Passive, high-side ▪ Option FA: IO-Link, 1 pulse/frequency/switch output Active, high-side
Maximum output values	<ul style="list-style-type: none"> ▪ Option AA: 2 pulse/frequency/switch outputs <ul style="list-style-type: none"> ▪ DC 30 V ▪ 30 mA ▪ Option FA: IO-Link, 1 pulse/frequency/switch output <ul style="list-style-type: none"> ▪ DC 30 V ▪ 100 mA
Voltage drop	<ul style="list-style-type: none"> ▪ Option AA: 2 pulse/frequency/switch outputs At 25 mA: ≤ DC 3 V ▪ Option FA: IO-Link, 1 pulse/frequency/switch output At 100 mA: ≤ DC 3 V
Pulse output	
Pulse width	Configurable: 0.05 to 2 000 ms
Maximum pulse rate	10 000 Impulse/s
Pulse value	Configurable
Assignable measured variables	<ul style="list-style-type: none"> ▪ Mass flow ▪ Volume flow
Frequency output	
Output frequency	Configurable: 0 to 10 000 Hz
Damping	Configurable: 0 to 999.9 s
Pulse/pause ratio	1:1
Assignable measured variables	<ul style="list-style-type: none"> ▪ Mass flow ▪ Volume flow ▪ Density ▪ Temperature ▪ Exciter current ▪ Oscillation frequency ▪ Oscillation amplitude ▪ Frequency fluctuation ▪ Oscillation damping ▪ Fluctuation ▪ Signal asymmetry
Switch output	
Switching behavior	Binary, conductive or non-conductive

Number of switching cycles	Unlimited
Assignable functions	<ul style="list-style-type: none"> ▪ Off ▪ On ▪ Diagnostic behavior <ul style="list-style-type: none"> ▪ Alarm ▪ Alarm and warning ▪ Warning ▪ Limit value <ul style="list-style-type: none"> ▪ Mass flow ▪ Volume flow ▪ Density ▪ Temperature ▪ Totalizer 1-3 ▪ Oscillation damper ▪ Flow direction monitoring ▪ Status <ul style="list-style-type: none"> ▪ Partially filled pipe detection ▪ Low flow cut off

IO-Link

Physical interface	According to Standard IEC 61131-9
Signal	IO-Link digital communication signal, 3-wire
IO-Link version	1.1
IO-Link SSP version	Identification and Diagnosis, Measuring and Switching Sensor (as per SSP 4.3.4)
IO-Link device port	IO-Link port class A

 The pin assignment deviates from the IO-Link standard to enable compatibility with previous device versions and installations.

Modbus RS485

Physical interface	RS485 according to Standard EIA/TIA-485-A
---------------------------	---

Switch output (batch: valve control)

 Only available for device version with Modbus RS485 →  13.

Switch output (batch)	
Version	Active, high-side
Maximum output values	<ul style="list-style-type: none"> ▪ DC 30 V ▪ 500 mA
Switching behavior	Binary, conductive or non-conductive
Number of switching cycles	Unlimited
Assignable functions	<ul style="list-style-type: none"> ▪ Open ▪ Closed ▪ Batching

Status output

 Only available for device version with Modbus RS485 →  13.

Status output	
Version	Active, high-side
Maximum output values	<ul style="list-style-type: none"> ▪ DC 30 V ▪ 100 mA
Voltage drop	At 100 mA: ≤ DC 3 V
Switching behavior	Binary, conductive or non-conductive
Number of switching cycles	Unlimited
Assignable functions	<ul style="list-style-type: none"> ▪ Off ▪ Batching process status (batch) ▪ Batching process status (batch), output 1 ▪ Batching process status (batch), output 2

Signal on alarm

Depending on the interface, failure information is displayed as follows.

Pulse/frequency/switch output

Pulse output	
Failure mode	Choose from: <ul style="list-style-type: none"> ▪ Actual value ▪ No pulses
Frequency output	
Failure mode	Choose from: <ul style="list-style-type: none"> ▪ Actual value ▪ 0 Hz ▪ Definable value between: 0 to 10 000 Hz
Switch output	
Failure mode	Choose from: <ul style="list-style-type: none"> ▪ Current status ▪ Open ▪ Closed

IO-Link

Operating mode	Digital transmission of all failure information
Device status	Readable via cyclical and acyclical data transmission

Modbus RS485

Failure mode	Choose from: <ul style="list-style-type: none"> ▪ NaN value instead of current value ▪ Last valid value
--------------	---

Low flow cut off

The switch points for low flow cut off are user-selectable.

Galvanic isolation

- Device version: 2 pulse/frequency/switch outputs
(Order code for "Output, input": option AA)
 - Pulse/frequency/switch outputs galvanically isolated from supply potential.
 - Pulse/frequency/switch outputs not galvanically isolated from each other.
- Device version: IO-Link, 1 pulse/frequency/switch output
(Order code for "Output, input": option FA)
Pulse/frequency/switch outputs on supply potential.
- Device version: Modbus RS485, 2 switch outputs (batch), 1 status output, 1 status input
(Order code for "Output, input": option MD)
 - Switch outputs (batch) on supply potential.
 - Status output on supply potential.
 - Status input galvanically isolated (connection C/D) or on supply potential (connection A/B)

Protocol-specific data

IO-Link

IO-Link specification	Version 1.1.3
Device ID	0x947401 (9729281)
Manufacturer ID	0x0011 (17)
Smart Sensor Profile 2nd Edition	Supports <ul style="list-style-type: none"> ▪ Identification and Diagnosis ▪ Digital Measuring and Switching Sensor (as per SSP type 4.3.4)
Smart Sensor Profile Type	Measuring profile type 4.3.4 Measuring and Switching Sensor, floating point, 4 channel
SIO	Yes
IO-Link transmission rate	COM3; 230.4 kBd
Minimum period	1.5 ms
Process data width input/output	18 bytes/2 bytes (as per SSP 4.3.4)
OnRequestdata PreOp/Op	8 bytes/2 bytes
Data storage	Yes
Block configuration	Yes
Device operational	The device is operational 3 seconds after the supply voltage is applied
System integration	Input cyclic process data <ul style="list-style-type: none"> ▪ Mass flow [kg/s] ▪ Density [kg/m³] ▪ Totalizer 1 [kg] ▪ Temperature [°C] Output cyclic process data <ul style="list-style-type: none"> ▪ Control signal channel - Volume flow ▪ Control signal channel - Density ▪ Control signal channel - Temperature ▪ Control signal channel - Totalizer 1 ▪ Flow override ▪ Totalizer 1 - Hold ▪ Totalizer 1 - Reset + totalize ▪ Totalizer 1 - Reset + hold ▪ Totalizer 1 - Totalize

Device description



In order to integrate field devices into a digital communication system, the IO-Link system needs a description of the device parameters, such as output data, input data, data format, data volume and supported transmission rate.

The data are included in the device description (IODD) that are provided to the IO-Link master during commissioning of the communication system.

The IODD can be downloaded as follows:

- www.endress.com
- <https://ioddfinder.io-link.com>

Modbus RS485



Protocol	Modbus Applications Protocol Specification V1.1
Device type	Slave
Slave address range	1 to 247
Broadcast address range	0
Function codes	<ul style="list-style-type: none"> ▪ 03: Read holding register ▪ 04: Read input register ▪ 06: Write single registers ▪ 08: Diagnostics ▪ 16: Write multiple registers ▪ 23: Read/write multiple registers ▪ 43: Read device identification
Broadcast messages	Supported by the following function codes: <ul style="list-style-type: none"> ▪ 06: Write single registers ▪ 16: Write multiple registers ▪ 23: Read/write multiple registers
Supported baud rate	<ul style="list-style-type: none"> ▪ 1 200 BAUD ▪ 2 400 BAUD ▪ 4 800 BAUD ▪ 9 600 BAUD ▪ 19 200 BAUD ▪ 38 400 BAUD ▪ 57 600 BAUD ▪ 115 200 BAUD ▪ 230 400 BAUD
Data transfer mode	RTU
Data access	Each device parameter can be accessed via Modbus RS485.  For Modbus register information →  49

Power supply

Terminal assignment

Connection is solely by means of device plug.

There are different device versions available:

Order code for "Output, input"	Device plug
Option AA: 2 pulse/frequency/switch outputs	→  13
Option FA: IO-Link, 1 pulse/frequency/switch output	→  14
Option MD: Modbus RS485, 2 switch outputs (batch), 1 status output, 1 status input	→  15

Available device plugs

Device version: 2 pulse/frequency/switch outputs

Order code for "Output, input": option AA:
2 pulse/frequency/switch outputs

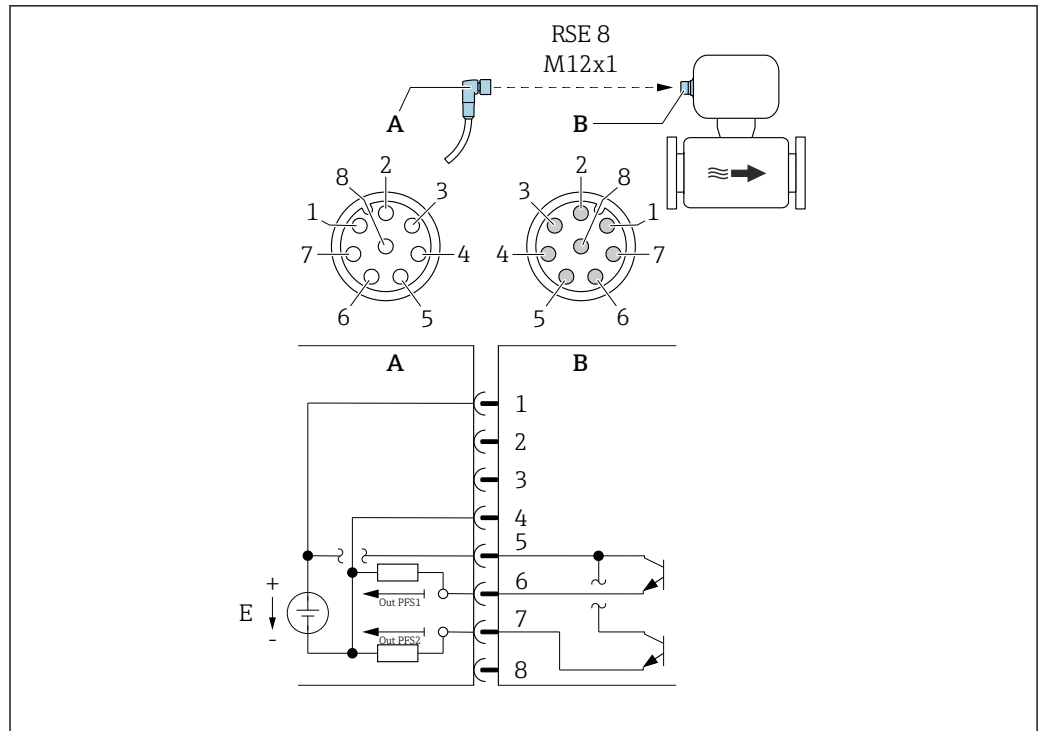

A0054873

6 Connection to device

- A Coupling: Supply voltage, pulse/freq./switch output
- B Connector: Supply voltage, pulse/freq./switch output
- E PELV or SELV power supply
- 1 to 8 Pin assignment

Pin assignment

Connection: Coupling (A) – Connector (B)		
Pin	Assignment	
1	L+	Supply voltage
2	+	Service interface RX
3	+	Service interface TX
4	L-	Supply voltage
5	+	Pulse/frequency/switch output 1 and 2
6	-	Pulse/frequency/switch output 1
7	-	Pulse/frequency/switch output 2
8	-	Service interface GND

Observe cable specifications → 19.

Device version: IO-Link, 1 pulse/frequency/switch output

Order code for "Output, input", option FA:

- IO-Link
- 1 pulse/frequency/switch output

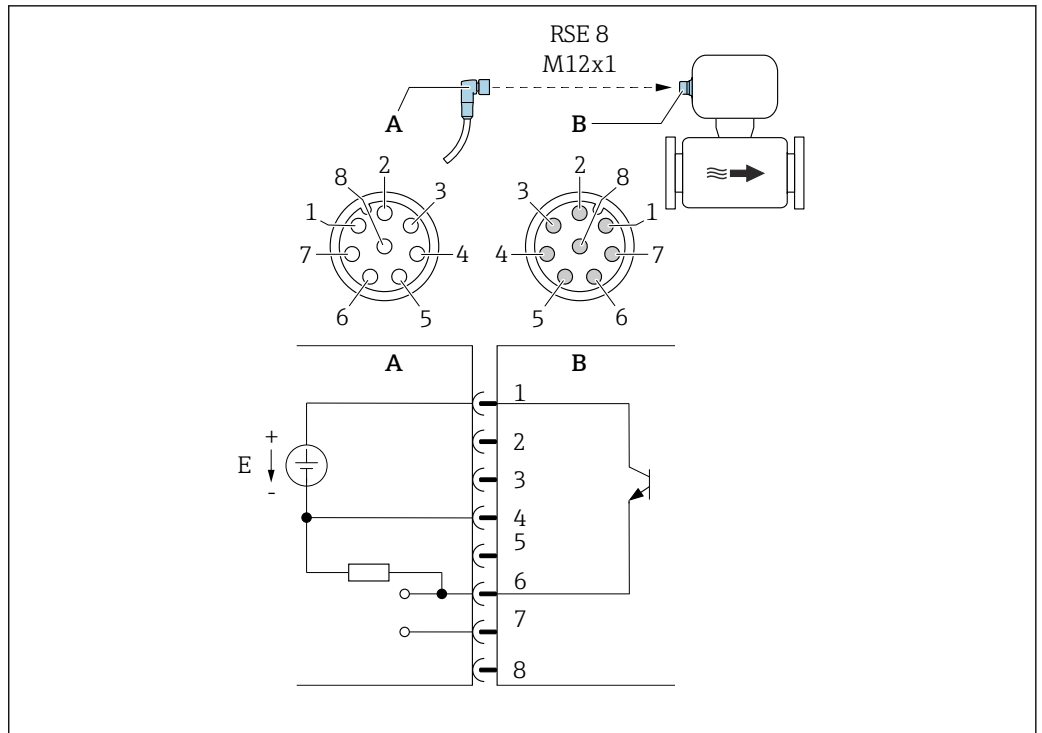

A0053318

7 Connection to device

- A Coupling: Supply voltage, pulse/freq./switch output
- B Connector: Supply voltage, pulse/freq./switch output
- E PELV or SELV power supply
- 1 to Pin assignment
- 8

Pin assignment

Connection: Coupling (A) – Connector (B)		
Pin	Assignment	
1	L+	Supply voltage
2	+	Service interface RX
3	+	Service interface TX
4	L-	Supply voltage
5	Not used	
6	-	Pulse/frequency/switch output DQ
7	-	IO-Link communication signal C/Q
8	-	Service interface GND

i The pin assignment deviates from the IO-Link standard to enable compatibility with previous device versions and installations.

i Observe cable specifications → 19.

Device version: Modbus RS485, 2 switch outputs (batch), 1 status output, 1 status input

Order code for "Output, input", option MD:

- Modbus RS485
- 2 switch outputs (batch)
- 1 status output
- 1 status input

Version 1: Status input via connection A/B

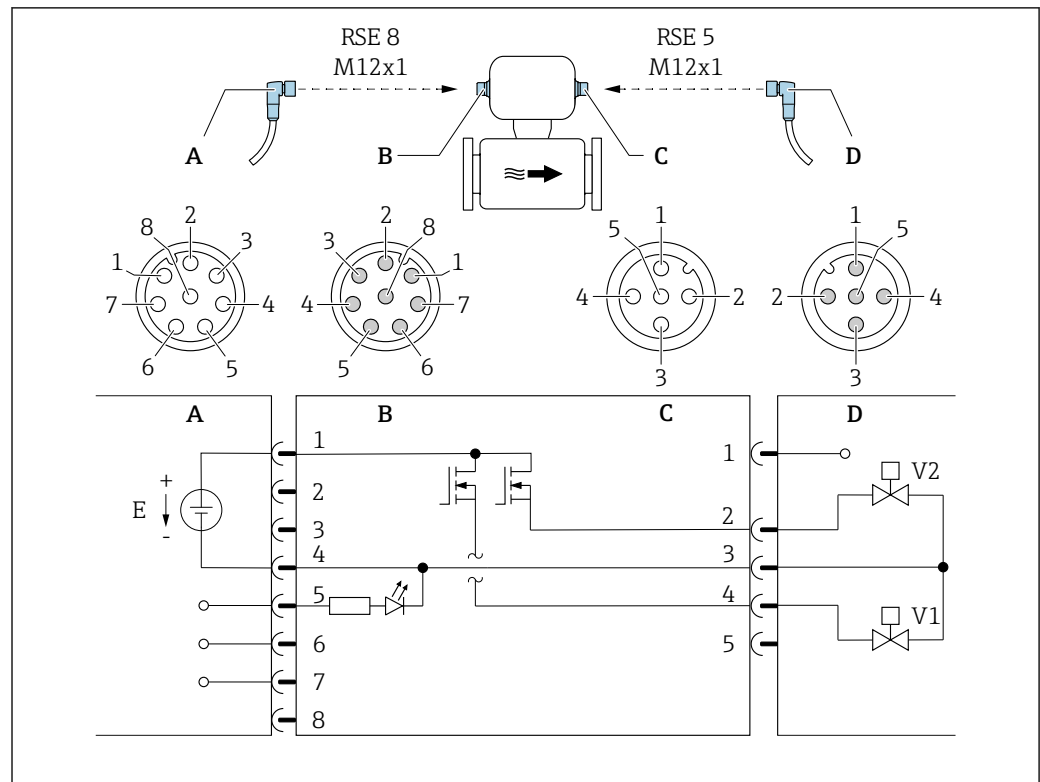

A0053319

8 Connection to device

- A Coupling: Supply voltage, Modbus RS485, status input
- B Connector: Supply voltage, Modbus RS485, status input
- C Coupling: Switch output (batch)
- D Connector: Switch output (batch)
- E PELV or SELV power supply
- V1 Valve (batch), level 1
- V2 Valve (batch), level 2
- 1 to Pin assignment
- 8

Version 2: Status output via connection A/B

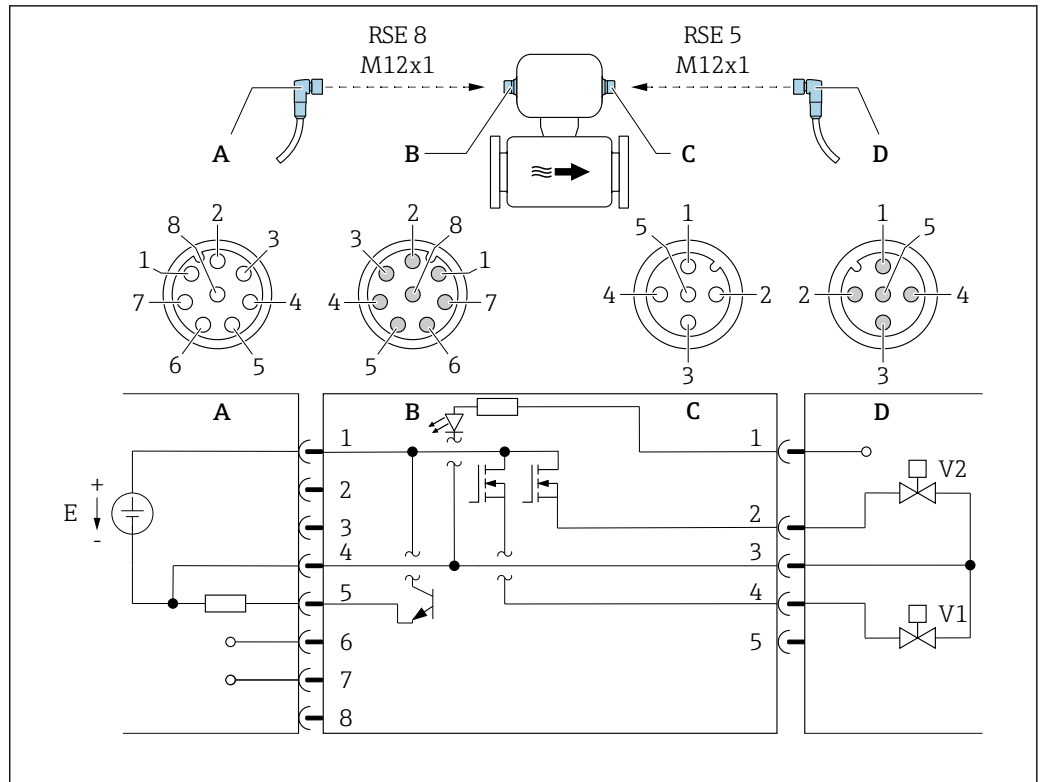

A0053323

9 Connection to device

- A Coupling: Supply voltage, Modbus RS485, status output
- B Connector: Supply voltage, Modbus RS485, status output
- C Coupling: Switch output (batch), status input
- D Connector: Switch output (batch), status input
- E PELV or SELV power supply
- V1 Valve (batch), level 1
- V2 Valve (batch), level 2
- 1 to Pin assignment
- 8

Pin assignment

Connection: Coupling (A) – Connector (B)			Connection: Coupling (C) – Connector (D)		
Pin	Assignment		Pin	Assignment	
1	L+	Supply voltage	1	+	Status input
2	+	Service interface RX	2	+	Switch output (batch) 2
3	+	Service interface TX	3	-	Switch output (batch) 1 and 2, status input
4	L-	Supply voltage	4	+	Switch output (batch) 1
5	+	Status output/Status input ¹⁾	5	Not used	
6	+	Modbus RS485			
7	-	Modbus RS485			
8	-	Service interface GND			

1) The functionality of status input and status output is not possible at the same time.

Observe cable specifications → 19.

Supply voltage

DC 24 V (nominal voltage: DC 18 to 30 V)



- The power unit must be tested to ensure that it meets safety requirements (e.g. PELV/SELV Class II limited energy).
- The equipment is classified as Class III.

Power consumption

2.5 W (no outputs)

Current consumption

Order code for "Output, input"	Maximum Current consumption
Option AA: 2 pulse/frequency/switch outputs	100 mA
Option FA: IO-Link, 1 pulse/frequency/switch output	100 mA + 100 mA ¹⁾
Option MD: Modbus RS485, 2 switch outputs (batch), 1 status output, 1 status input	100 mA + 1 100 mA ²⁾

- 1) When pulse/frequency/switch output is used
 2) Per switch output used (batch) 500 mA, status output 100 mA

Switch-on current

- Option AA: 2 pulse/frequency/switch outputs
Max. 1.2 A (< 15 ms)
- Option FA: IO-Link, 1 pulse/frequency/switch output
Max. 400 mA (< 20 ms)
- Option MD: Modbus RS485, 2 switch outputs (batch), 1 status output, 1 status input
Max. 1.2 A (< 15 ms)

Power supply failure

- Totalizers stop at the last value measured.
- Configuration is retained in the device memory.
- Error messages (incl. total operated hours) are stored.

Electrical connection

Connection is solely by means of device plug.

Device version: 2 pulse/frequency/switch outputs and IO-Link, 1 pulse/frequency/switch output

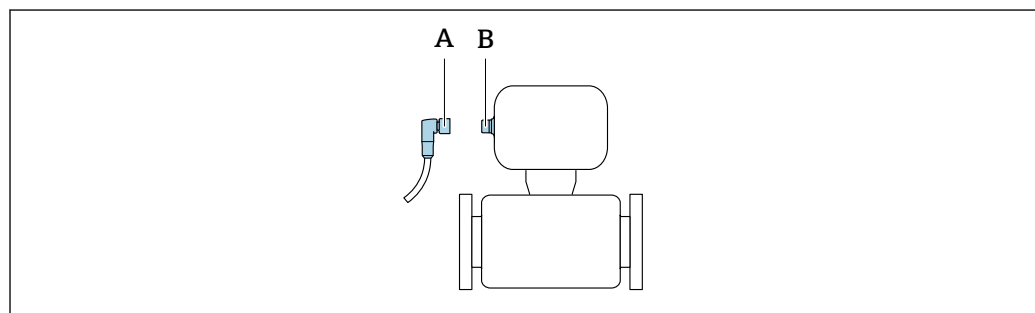

A0032652

- A Coupling
 B Connector

Device version: Modbus RS485, 2 switch outputs (batch), 1 status output, 1 status input

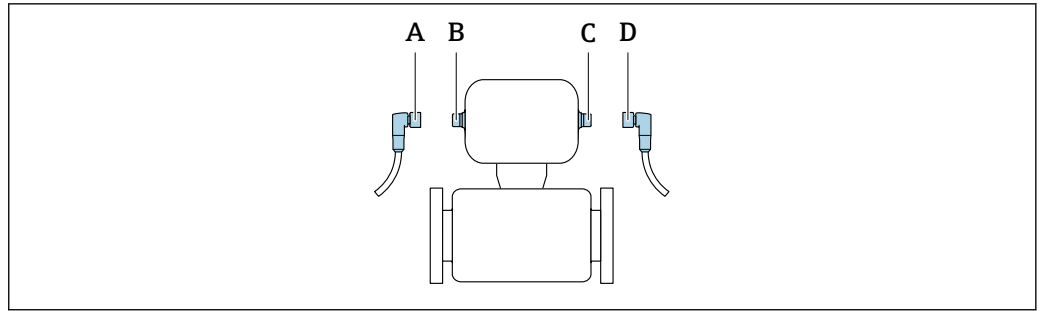

A0032534

A, C Coupling
B, D Connector

There are different device versions available:

Order code for "Output, input"	Device plug
Option AA: 2 pulse/frequency/switch outputs	→ 13
Option FA: IO-Link, 1 pulse/frequency/switch output	→ 14
Option MD: Modbus RS485, 2 switch outputs (batch), 1 status output, 1 status input	→ 15

Grounding

Grounding is by means of a cable socket.

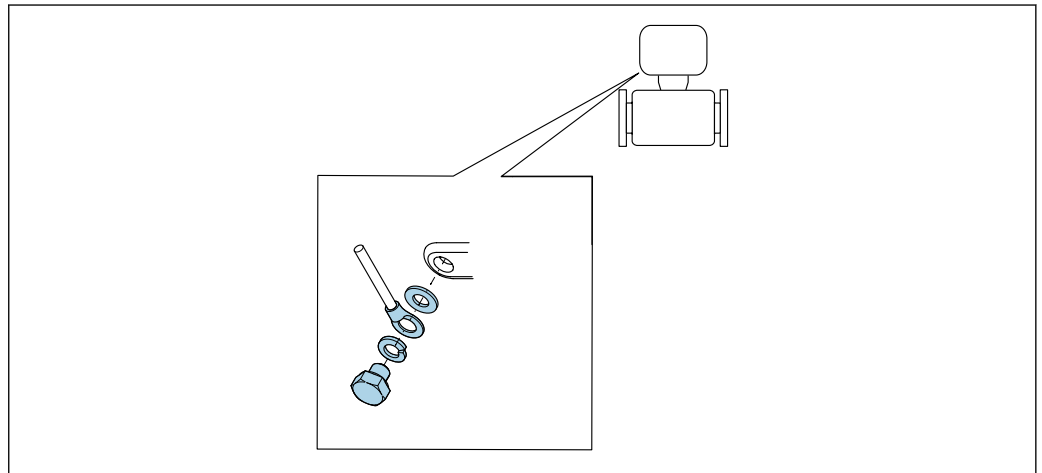

A0053306

Ensuring

No special measures for potential equalization are required.

Cable specification

Permitted temperature range

- The installation guidelines that apply in the country of installation must be observed.
- The cables must be suitable for the minimum and maximum temperatures to be expected.

Signal cable

i Cables are not included in the scope of delivery.

i Please note the following with regard to cable loading:

- Voltage drop due to the cable length and cable type.
- Valve performance.

Pulse/frequency/switch output

Standard installation cable is sufficient.

IO-Link

Unshielded cable with 3 (or 4) conductors.



See <https://io-link.com>"IO-Link System Description"

Switch output (batch), status output and status input

Standard installation cable is sufficient.

Modbus RS485



- The electrical connection of the shield to the device housing must be properly implemented (e.g. using a knurled nut).
- Please note the following with regard to cable loading:
 - Voltage drop due to the cable length and cable type.
 - Valve performance.

Total length of cable in the Modbus network ≤ 50 m

Use a shielded cable.

Example:

Terminated device plug with cable: Lumberg RKWTH 8-299/10

Total length of cable in the Modbus network > 50 m

Use shielded twisted pair cable for RS485 applications.

Example:

- Cable: Belden item no. 9842 (for 4-wire version, the same cable can be used for the power supply)
- Terminated device plug: Lumberg RKCS 8/9 (shieldable version)

Terminating resistor

The Modbus RS485 network must be terminated with a terminating resistor and polarization.

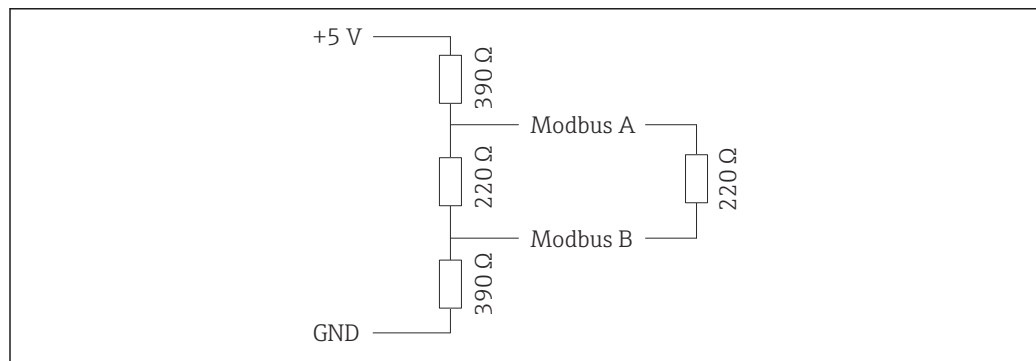

A0024990

Performance characteristics

Reference operating conditions

- Error limits based on ISO 11631
- Water
 - +15 to +45 °C (+59 to +113 °F)
 - 2 to 6 bar (29 to 87 psi)
- Data as indicated in the calibration protocol
- Accuracy based on accredited calibration rigs according to ISO 17025

Installation

- Measuring device is grounded.
- The sensor is centered in the pipe.



To obtain measured errors, use the *Applicator* sizing tool → 48

Maximum measurement error

o.r. = of reading; 1 g/cm³ = 1 kg/l; T = medium temperature

Base accuracy

Bases for calculation → 22

Mass flow and volume flow (liquids)

±0.15 %

Density (liquids)

Under reference conditions [g/cm ³]	Field density adjustment [g/cm ³]	Standard density calibration [g/cm ³]
±0.0005 g/cm ³	±0.0005 g/cm ³	±0.0025 g/cm ³

Temperature

±0.5 °C ± 0.005 · T °C (±0.9 °F ± 0.003 · (T - 32) °F)

Zero point stability

DN		Zero point stability	
[mm]	[in]	[kg/h]	[lb/min]
1	1/24	0.0005	0.000018
2	1/12	0.0025	0.00009
4	1/6	0.0100	0.00036
8	3/8	0.20	0.007
15	1/2	0.65	0.024
25	1	1.80	0.066
40	1 1/2	4.50	0.165

Flow values

Flow values as turndown parameters depending on nominal diameter.

SI units

DN [mm]	1:1	1:10	1:20	1:50	1:100	1:500
	[kg/h]	[kg/h]	[kg/h]	[kg/h]	[kg/h]	[kg/h]
1	20	2	1	0.4	0.2	0.04
2	100	10	5	2	1	0.2
4	450	45	22.5	9	4.5	0.9
8	2000	200	100	40	20	4
15	6500	650	325	130	65	13
25	18000	1800	900	360	180	36
40	45000	4500	2250	900	450	90

US units

DN	1:1	1:10	1:20	1:50	1:100	1:500
[in]	[lb/min]	[lb/min]	[lb/min]	[lb/min]	[lb/min]	[lb/min]
1/24	0.735	0.074	0.037	0.015	0.007	0.001
1/12	3.675	0.368	0.184	0.074	0.037	0.007
1/8	16.54	1.654	0.827	0.331	0.165	0.033
3/8	73.50	7.350	3.675	1.470	0.735	0.147
1/2	238.9	23.89	11.95	4.778	2.389	0.478
1	661.5	66.15	33.08	13.23	6.615	1.323
1 1/2	1654	165.4	82.70	33.08	16.54	3.308

Accuracy of outputs

 The output accuracy must be factored into the measurement error if analog outputs are used; but can be ignored for fieldbus outputs (IO-Link and Modbus RS485).

The outputs have the following base accuracy specifications.

Pulse/frequency output

o.r. = of reading

Temperature accuracy	Max. ±50 ppm o.r. (over the entire ambient temperature range)
-----------------------------	---

Repeatability

Base repeatability

Dosing time [s]	Standard deviation [%]
0.75 s < t _a < 1.5 s	0.2
1.5 s < t _a < 3 s	0.1
3 s < t _a	0.05

Density (liquids)

±0.00025 g/cm³

Temperature

±0.25 °C ± 0.0025 · T °C (±0.45 °F ± 0.0015 · (T-32) °F)

Response time

The response time depends on the configuration (damping).

Influence of ambient temperature

Pulse/frequency output

Temperature coefficient	No additional effect. Included in accuracy.
--------------------------------	---

Influence of medium temperature

Mass flow

If there is a differential between the temperature during zero adjustment and the process temperature, the typical measurement error of the sensor is ±0.0002 % of the full scale value/°C (±0.0001 % of the full scale value/°F).

Temperature

±0.005 · T °C (± 0.005 · (T - 32) °F)

Influence of medium pressure

A difference between the calibration pressure and process pressure does not affect accuracy.

Design fundamentals

o.r. = of reading, o.f.s. = of full scale value

BaseAccu = base accuracy in % o.r., BaseRepeat = base repeatability in % o.r.

MeasValue = measured value; ZeroPoint = zero point stability

Calculation of the maximum measured error as a function of the flow rate

Flow rate	Maximum measured error in % o.r.
$\geq \frac{\text{ZeroPoint}}{\text{BaseAccu}} \cdot 100$ <small>A0021332</small>	$\pm \text{BaseAccu}$ <small>A0021339</small>
$< \frac{\text{ZeroPoint}}{\text{BaseAccu}} \cdot 100$ <small>A0021333</small>	$\pm \frac{\text{ZeroPoint}}{\text{MeasValue}} \cdot 100$ <small>A0021334</small>

Calculation of the maximum repeatability as a function of the flow rate

Flow rate	Maximum repeatability in % o.r.
$\geq \frac{1/2 \cdot \text{ZeroPoint}}{\text{BaseRepeat}} \cdot 100$ <small>A0021335</small>	$\pm \text{BaseRepeat}$ <small>A0021340</small>
$< \frac{1/2 \cdot \text{ZeroPoint}}{\text{BaseRepeat}} \cdot 100$ <small>A0021336</small>	$\pm 1/2 \cdot \frac{\text{ZeroPoint}}{\text{MeasValue}} \cdot 100$ <small>A0021337</small>

Example of maximum measurement error

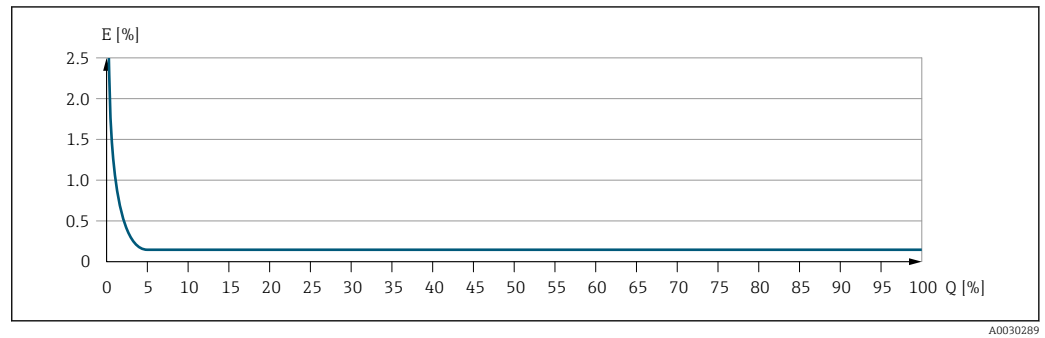

E Maximum measurement error in % o.r. (example)
Q Flow rate in % of maximum full scale value

Mounting

Installation point

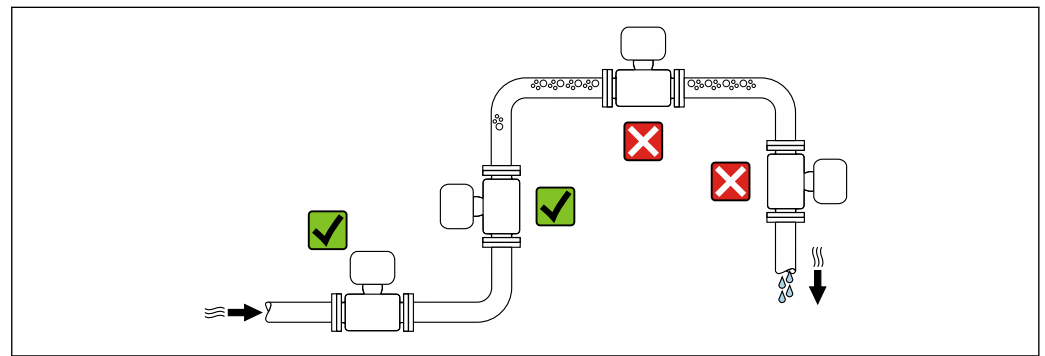

To prevent measuring errors arising from accumulation of gas bubbles in the measuring pipe, avoid the following mounting locations in the piping:

- Highest point of a pipeline.
- Directly upstream of a free pipe outlet in a down pipe.

Installation in down pipes

However, the following installation suggestion allows for installation in an open vertical pipeline. Pipe restrictions or the use of an orifice with a smaller cross-section than the nominal diameter prevent the sensor running empty while measurement is in progress.

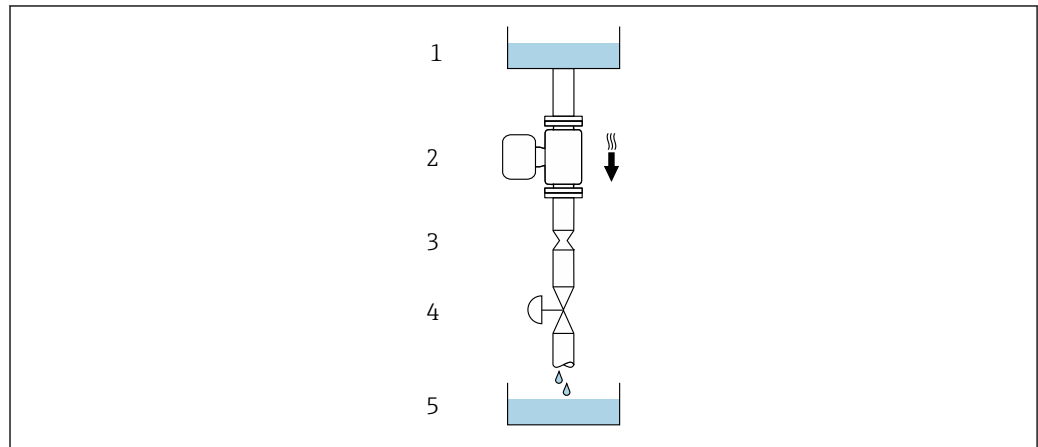

A0028773

10 Installation in a down pipe (e.g. for batching applications)

- 1 Supply tank
- 2 Sensor
- 3 Orifice plate, pipe restriction
- 4 Valve
- 5 Filling vessel



DN		Ø orifice plate, pipe restriction	
[mm]	[in]	[mm]	[in]
1	1/24	0.8	0.03
2	1/12	1.5	0.06
4	1/8	3.0	0.12
8	3/8	6	0.24
15	1/2	10	0.40
25	1	14	0.55
40	1 1/2	22	0.87

Orientation

The direction of the arrow on the sensor nameplate helps you to install the sensor according to the flow direction (direction of medium flow through the piping).

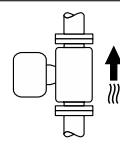
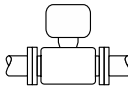

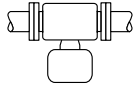
Recommended orientation for DN 1 to 4 (1/24 to 1/8 ")

Orientation		Recommendation
A	Vertical orientation	 <small>A0015591</small> <input checked="" type="checkbox"/> <input checked="" type="checkbox"/> ¹⁾
B	Horizontal orientation, transmitter at top	 <small>A0015589</small> <input checked="" type="checkbox"/> ²⁾

Orientation		Recommendation
C	Horizontal orientation, transmitter at bottom	 A0015590 ✓ ³⁾
D	Horizontal orientation, transmitter at side	 A0015592 ✓

- 1) This orientation is recommended to ensure self-draining.
- 2) Applications with low process temperatures may reduce the ambient temperature. To maintain the minimum ambient temperature for the transmitter, this orientation is recommended.
- 3) Applications with high process temperatures may increase the ambient temperature. To maintain the maximum ambient temperature for the transmitter, this orientation is recommended.

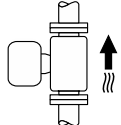
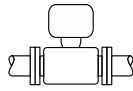
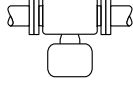
Recommended orientation for DN 8 to 40 (3/8 to 1 1/2")

Orientation		Recommendation
A	Vertical orientation	 A0015591 ✓✓ ¹⁾
B	Horizontal orientation, transmitter at top	 A0015589 ✓✓ ²⁾
C	Horizontal orientation, transmitter at bottom	 A0015590 ✓✓ ³⁾
D	Horizontal orientation, transmitter at side	 A0015592 ✗

- 1) This orientation is recommended to ensure self-draining.
- 2) Applications with low process temperatures may reduce the ambient temperature. To maintain the minimum ambient temperature for the transmitter, this orientation is recommended.
- 3) Applications with high process temperatures may increase the ambient temperature. To maintain the maximum ambient temperature for the transmitter, this orientation is recommended.

Horizontal orientation for DN 8 to 40 (3/8 to 1 1/2")

If a sensor is installed horizontally with a curved measuring tube, match the position of the sensor to the fluid properties.

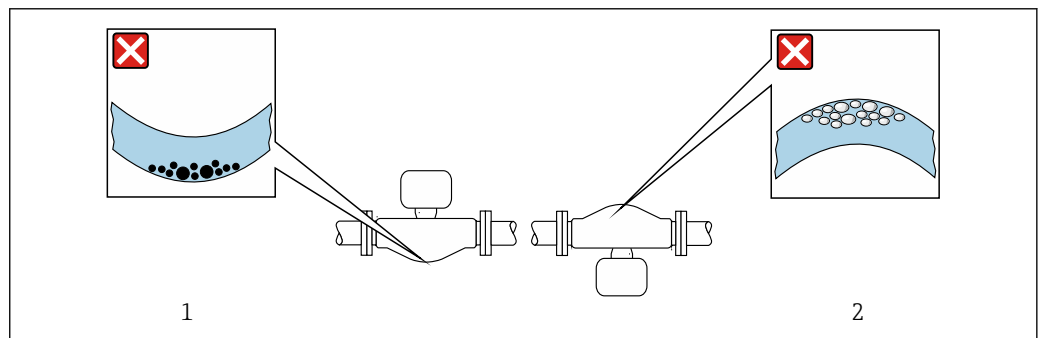

11 Orientation of sensor with curved measuring tube

- 1 Avoid this orientation for fluids with entrained solids: Risk of solids accumulating
- 2 Avoid this orientation for outgassing fluids: Risk of gas accumulating

Valves

Never install the sensor downstream from a filling valve. If the sensor is completely empty this corrupts the measured value.

i Correct measurement is possible only if the piping is completely filled. Perform sample fillings before commencing filling in production.

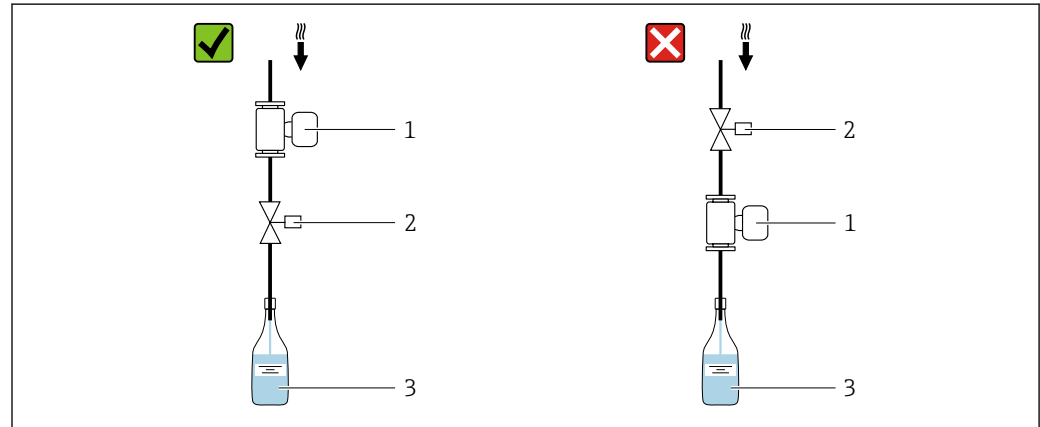

A0003768

- 1 Measuring device
- 2 Filling valve
- 3 Vessel

Filling systems

The pipe system must be completely full to ensure optimum measurement.

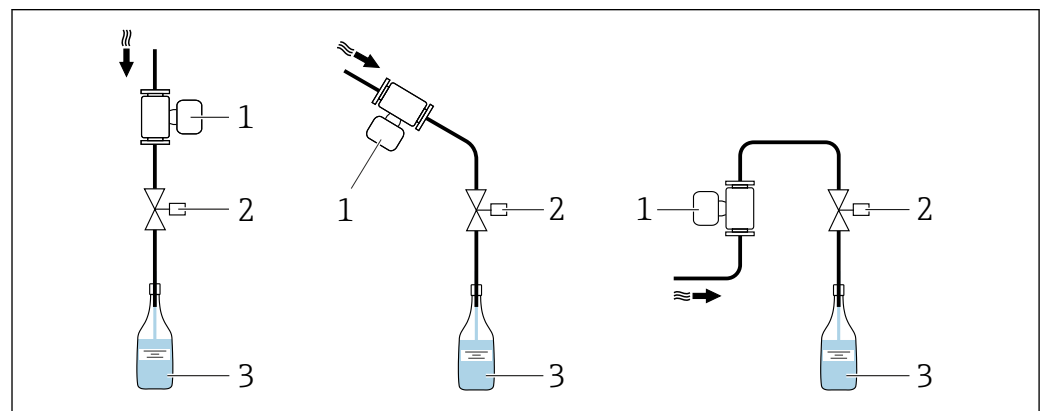

A0003795

12 Filling system

- 1 Measuring device
- 2 Filling valve
- 3 Vessel

Inlet and outlet runs

No special precautions need to be taken for fittings that create turbulence, such as valves, elbows or T-pieces, as long as no cavitation occurs.

Special mounting instructions

Information for filling systems

Correct measurement is only possible if the pipe is completely full. We therefore recommend that some test batches be carried out prior to production batching.

Circular filling system

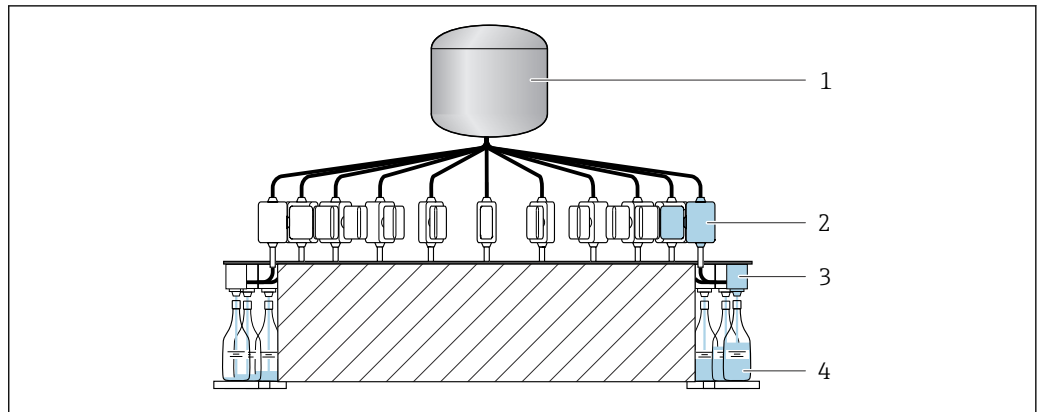

A0003761

- 1 Tank
- 2 Measuring instrument
- 3 Filling valve
- 4 Vessel

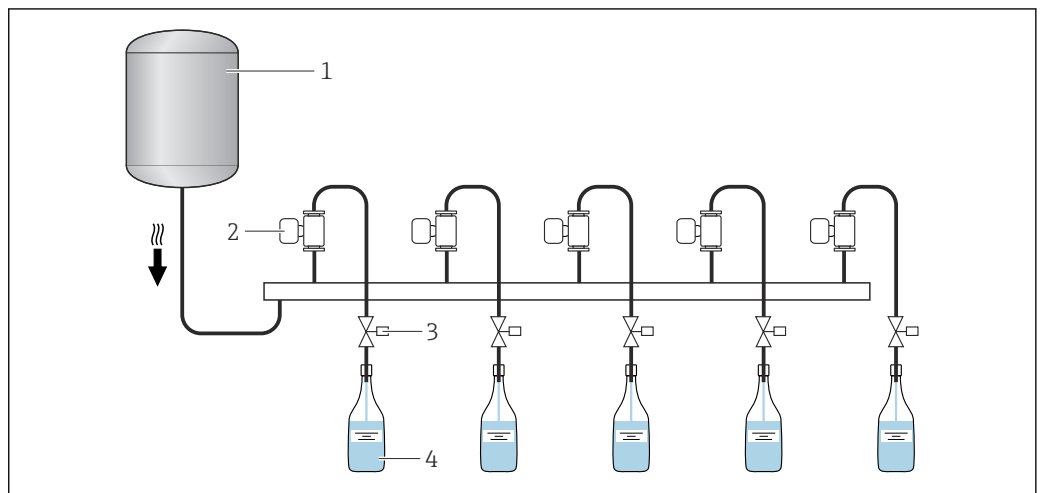

Linear filling system



A0003762

- 1 Tank
- 2 Measuring instrument
- 3 Filling valve
- 4 Vessel

Hygienic compatibility

 When installing in hygienic applications, please refer to the information in the "Certificates and approvals/hygienic compatibility" section →  46

Sensor holder DN 1 to 4 (1/24 to 1/8")

- The appropriate sensor holder must be used for all applications with increased safety or load requirements and for sensors with clamp process connections.
- The Endress+Hauser sensor holder is generally recommended for mounting for all applications → 48.

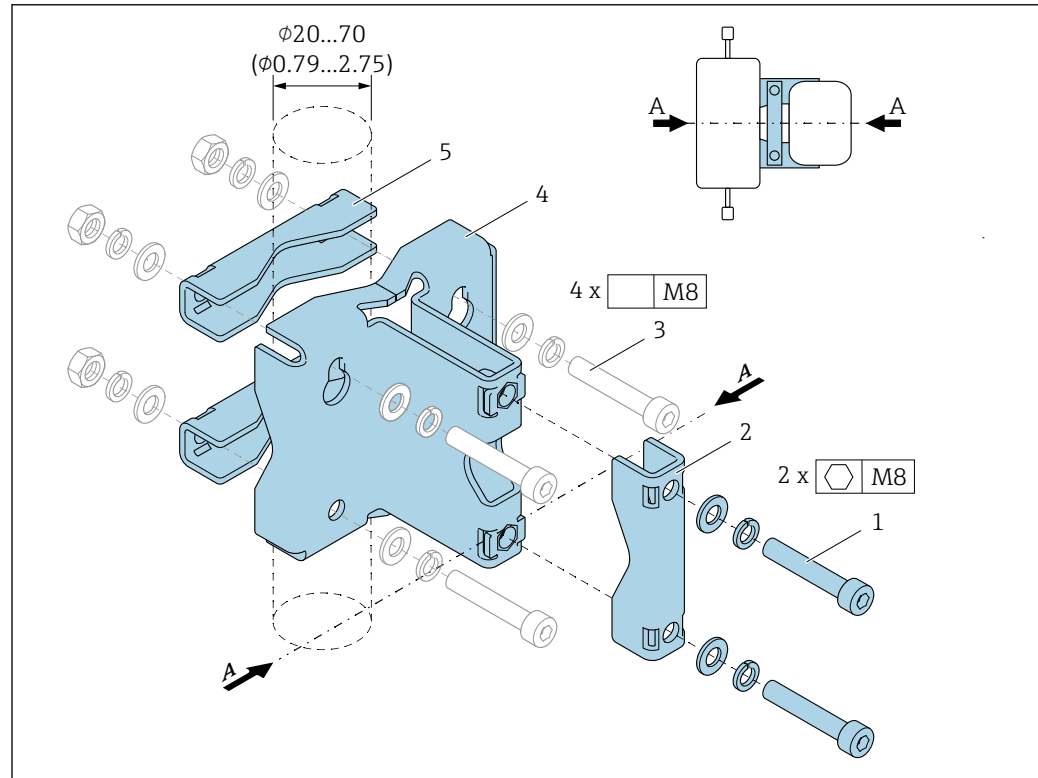

A0036471

- 1 2 x Allen screw M8 x 50, washer and spring washer A4
- 2 1 x clamp (measuring instrument neck)
- 3 4 x securing screw for wall, tabletop or pipe mounting (not supplied)
- 4 1 x base profile
- 5 2 x clamp (pipe mounting)
- A Measuring instrument central line

⚠ WARNING

Strain on pipes!

Excessive strain on an unsupported pipe can cause the pipe to break.

- Install the sensor in a sufficiently supported pipe. In addition to the use of the sensor holder, for maximum mechanical stability the sensor can also be supported on the inlet and outlet sides onsite at the installation location with the use of pipe clamps, for example.

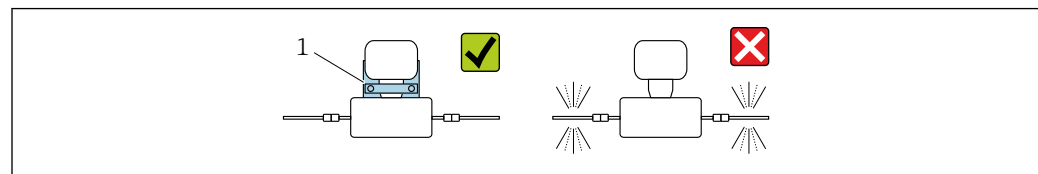

A0036492

- 1 Sensor holder Order number: 71392563

The following mounting versions are recommended for the installation:

- i** Lubricate all threaded joints prior to mounting. The screws for wall, tabletop or pipe mounting are not supplied with the device and must be chosen to suit the individual installation position.

Wall mounting

Screw the sensor holder to the wall with four screws. Two of the four holes to secure the holder are designed to hook into the screws.

Mounting on a table

Screw the sensor holder onto the tabletop with four screws.

Pipe mounting

Secure the sensor holder to the pipe with two clamps.



⚠ WARNING

Failure to comply with the specifications for vibration and shock resistance can damage the measuring instrument!

- ▶ During operation, transportation and storage, ensure compliance with the specifications for maximum vibration and shock resistance →  29.

Zero adjustment

The **Sensor adjustment** submenu contains parameters required for zero adjustment.

 Detailed information on the "**Sensor adjustment** submenu": Device parameters →  49

NOTICE

All Dosimass measuring instruments are calibrated in accordance with state-of-the-art technology. Calibration takes place under reference conditions .

Zero adjustment is therefore not required for the Dosimass as a general rule.

- ▶ Experience shows that a zero adjustment is advisable only in special cases.
- ▶ When maximum measurement accuracy is required and flow rates are very low.
- ▶ Under extreme process or operating conditions (e.g. very high process temperatures or very high-viscosity fluids).

 Detailed information on reference operating conditions →  20

Environment

Ambient temperature range	Transmitter	-40 to +60 °C (-40 to +140 °F)
	Sensor	-40 to +60 °C (-40 to +140 °F)
Storage temperature	-40 to +80 °C (-40 to +176 °F), preferably at +20 °C (+68 °F)	
Degree of protection	Standard: IP67, Type 4X enclosure, suitable for pollution degree 4	
Relative humidity	The device is suitable for use in outdoor and indoor areas (damp and wet areas) with a relative humidity of up to 95%.	
Operating altitude	According to EN 61010-1 ≤ 2 000 m (6 562 ft)	
Vibration-resistance and shock-resistance	Vibration sinusoidal, in accordance with IEC 60068-2-6	
	<ul style="list-style-type: none"> ■ 2 to 8.4 Hz, 3.5 mm peak ■ 8.4 to 2 000 Hz, 1 g peak 	
	Vibration broad-band random, according to IEC 60068-2-64	
	<ul style="list-style-type: none"> ■ 10 to 200 Hz, 0.003 g²/Hz ■ 200 to 2 000 Hz, 0.001 g²/Hz ■ Total: 1.54 g rms 	

Shock half-sine, according to IEC 60068-2-27

6 ms 30 g

Rough handling shocks according to IEC 60068-2-31

Electromagnetic compatibility (EMC)

As per IEC/EN 61326



Details are provided in the Declaration of Conformity.



This unit is not intended for use in residential environments and cannot guarantee adequate protection of the radio reception in such environments.

Overvoltage protection

Overvoltage category

Overvoltage category II, no connection to the mains supply

Process

Medium temperature range

Sensor

-40 to +130 °C (-40 to +266 °F)

Cleaning

+150 °C (+302 °F) for a maximum of 60 min for CIP and SIP processes

Seals

No internal seals

Medium pressure range

Max. 40 bar (580 psi), depending on the process connection

Medium density

	DN		ρ _{max} [kg/m ³]
	[mm]	[in]	
	1	1/24	3 150
	2	1/12	3 100
	4	1/8	3 100
	8	3/8	4 548
	15	1/2	4 900
	25	1	4 270
	40	1 1/2	4 700

Pressure-temperature ratings

The following pressure/temperature diagrams apply to all pressure-bearing parts of the device and not just the process connection. The diagrams show the maximum permissible medium pressure depending on the specific medium temperature.

Process connection: flange similar to EN 1092-1 (DIN 2501/DIN 2512 N), flange similar to EN 1092-1 (DIN 2501)

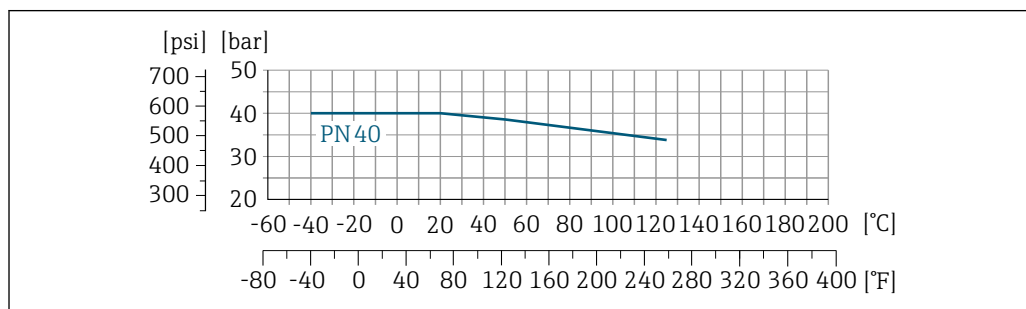

13 Process connection material: stainless steel 1.4404 (316/316L)

A0023105-EN

Process connection: 1" clamp similar to DIN 32676

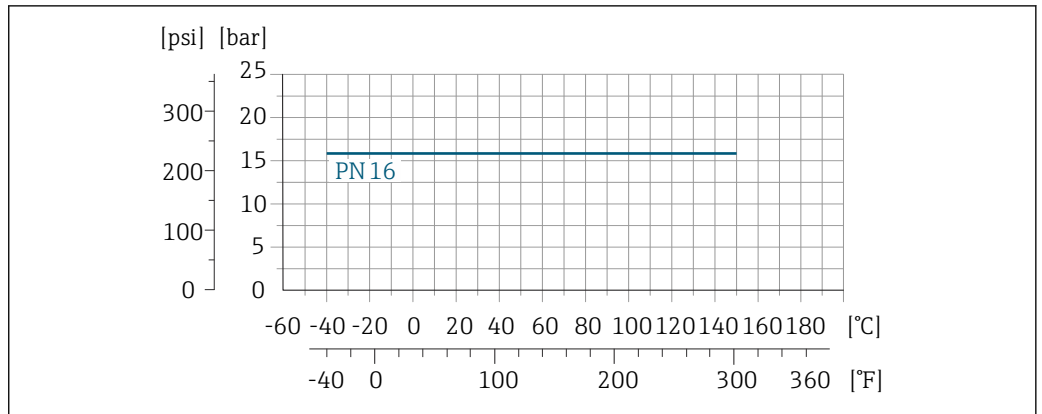

14 Process connection material: stainless steel 1.4404 (316/316L)

Process connection: Tri-Clamp

The load limit is defined exclusively by the material properties of the Tri-Clamp clamp used. This clamp is not included in the scope of delivery.

Process connection: thread similar to DIN 11864-1, Form A

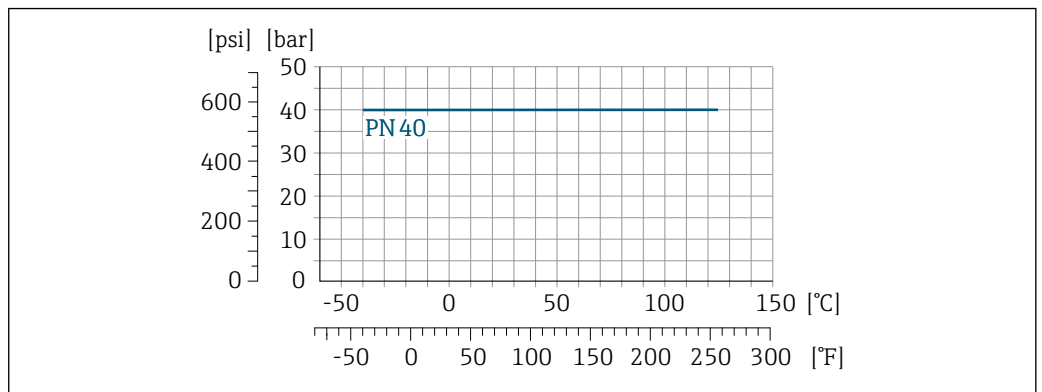

15 Process connection material: stainless steel 1.4404 (316/316L)

Process connection: thread similar to DIN 11851

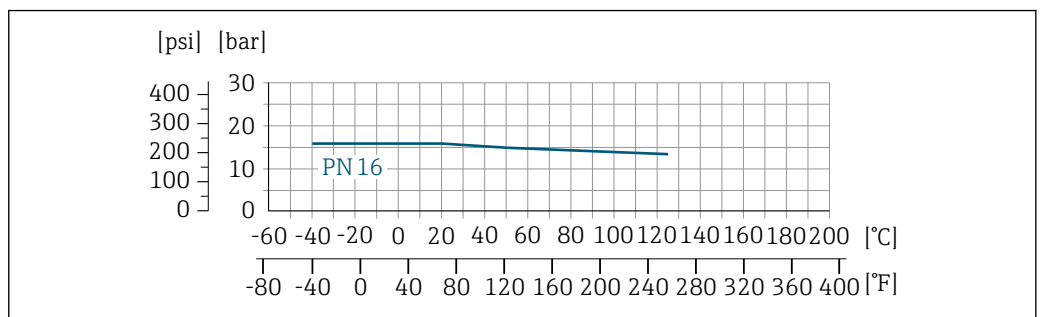

16 Process connection material: stainless steel 1.4404 (316/316L)

Process connection: thread similar to ISO 2853

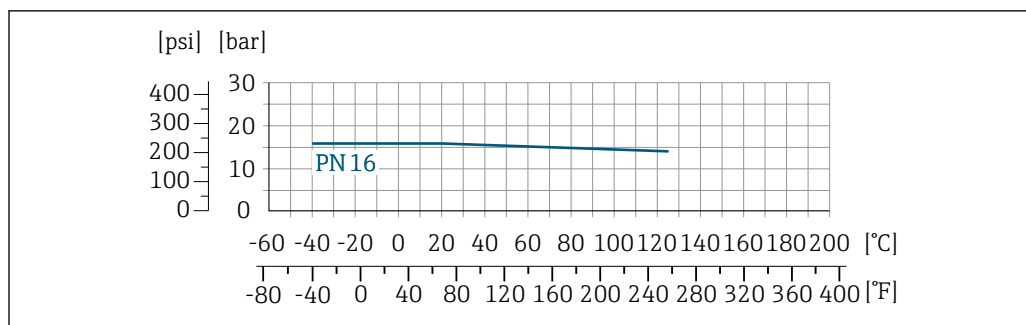

A0023112-EN

17 Process connection material: stainless steel 1.4404 (316/316L)

Sensor housing

The sensor housing is filled with dry nitrogen gas and protects the electronics and mechanics inside.

- The housing does not have a pressure rating classification.
- Reference value for the pressure loading capacity of the sensor housing: 16 bar (232 psi)

Flow limit

Select the nominal diameter by optimizing between the required flow range and permissible pressure loss.

i For an overview of the full scale values for the measuring range, see the "Measuring range" section → 7

- The minimum recommended full scale value is approx. 1/20 of the maximum full scale value
- In most applications, 20 to 50 % of the maximum full scale value can be considered ideal
- A low full scale value must be selected for abrasive media (such as liquids with entrained solids): flow velocity < 1 m/s (< 3 ft/s).

i To calculate the flow limit, use the *Applicator* sizing tool → 48

Pressure loss

i To calculate the pressure loss, use the *Applicator* sizing tool → 48

Heating

Some fluids require suitable measures to avoid loss of heat at the sensor.

Heating options

- Electrical heating, e.g. with electric band heaters ¹⁾
- Via pipes carrying hot water or steam
- Via heating jackets

NOTICE

Danger of overheating when heating

- ▶ Ensure that the temperature at the lower end of the transmitter housing does not exceed 80 °C (176 °F).
- ▶ Ensure that sufficient convection takes place at the transmitter neck.
- ▶ Ensure that a sufficiently large area of the transmitter neck remains exposed. The uncovered part serves as a radiator and protects the electronics from overheating and excessive cooling.

Vibrations

The high oscillation frequency of the measuring tubes ensures that the correct operation of the measuring system is not influenced by plant vibrations.

1) The use of parallel electric band heaters is generally recommended (bidirectional electricity flow). Particular considerations must be made if a single-wire heating cable is to be used. Additional information is provided in the document EA01339D "Installation instructions for electrical trace heating systems"

Mechanical construction

Dimensions in SI units

Compact version

Order code for "Housing", option B "Compact, stainless", DN 1 to 4 ($\frac{1}{2}$ " to $\frac{1}{8}$ ")

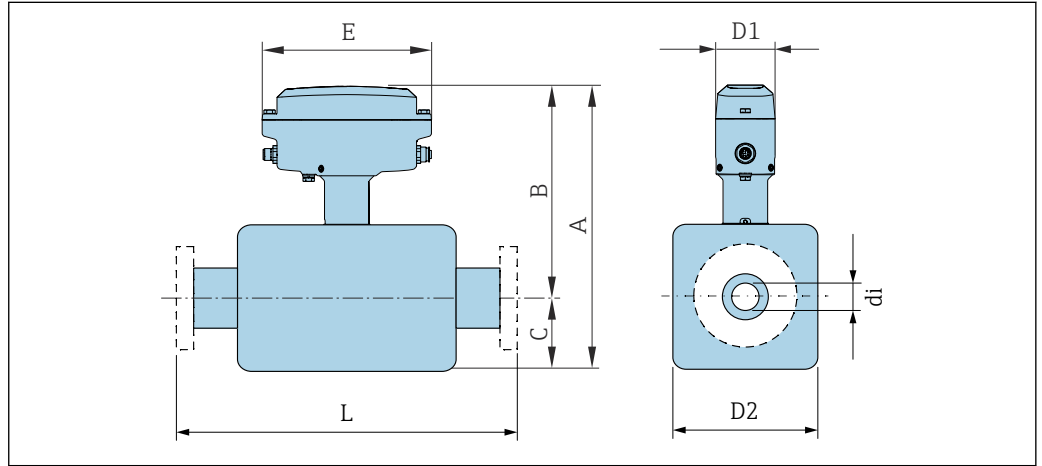

A0053344

DN [mm]	A [mm]	B [mm]	C [mm]	D1 [mm]	D2 [mm]	E [mm]	di [mm]	L [mm]
1	230	176	54	60	34	171	1.1	192
2	272	198	74	60	48	171	2.5	269
4	303	213	90	60	51	171	3.9	315

Order code for "Housing", option B "Compact, stainless", DN 8 to 40 ($\frac{3}{8}$ " to $1\frac{1}{2}$ ")

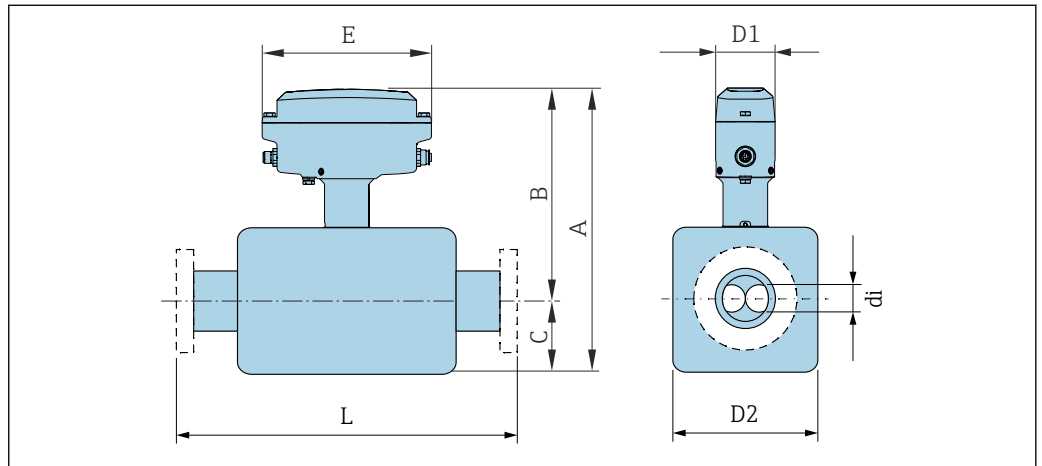

A0052375

DN [mm]	A [mm]	B [mm]	C [mm]	D1 [mm]	D2 [mm]	E [mm]	di [mm]	L [mm]
8	247	158	90	60	45	171	5.35	¹⁾
15	258	158	101	60	45	171	8.3	¹⁾
25	257	155	102	60	51	171	12	¹⁾
40	282	161	121	60	65	171	17.6	¹⁾

1) Depends on the particular process connection

Fixed flange

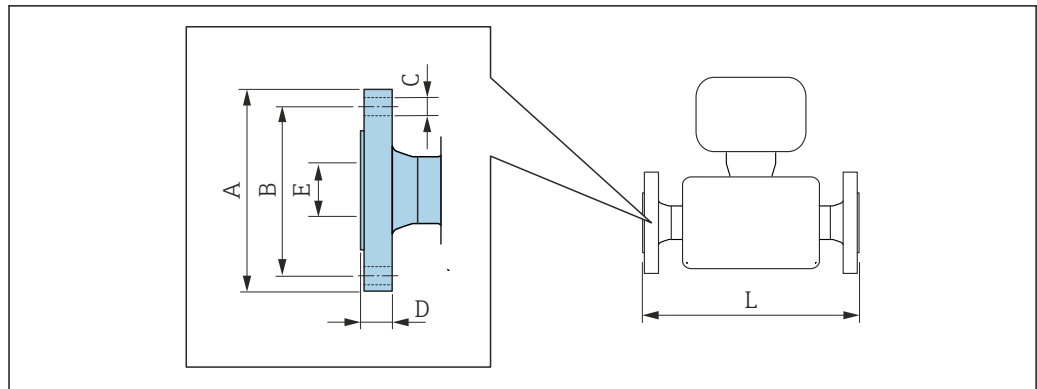

A0015621

i Length tolerance for dimension L in mm:
+1.5 / -2.0

Flange similar to EN 1092-1 (DIN 2501 / DIN 2512N): PN 40 1.4404 (316/316L): order code for "Process connection", option D2S						
DN [mm]	A [mm]	B [mm]	C [mm]	D [mm]	E [mm]	L [mm]
8	95	65	4 × Ø 14	16	17.3	232
15	95	65	4 × Ø 14	16	17.3	279
25	115	85	4 × Ø 14	18	28.5	329
40	150	110	4 × Ø 14	18	43.1	445

Flange similar to EN 1092-1 (DIN 2501): PN 40 (with DN 25 flanges) 1.4404 (316/316L): order code for "Process connection", option R2S						
DN [mm]	A [mm]	B [mm]	C [mm]	D [mm]	E [mm]	L [mm]
8	95	65	4 × Ø 14	16	17.3	198.4
15	95	65	4 × Ø 14	16	17.3	198.4

Clamp connection

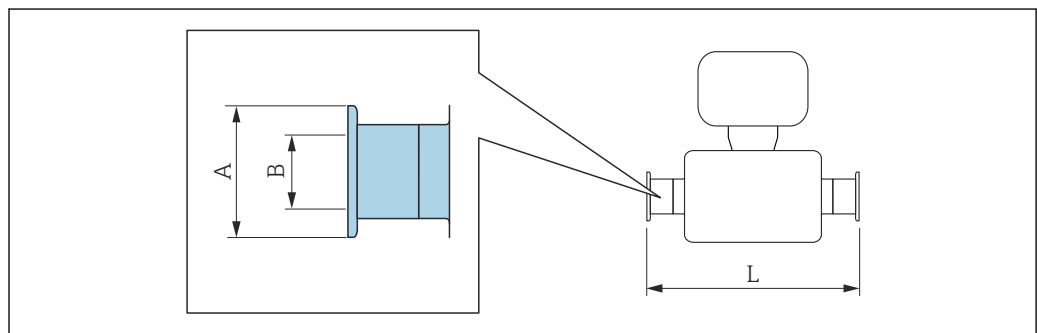

A0015625

i Length tolerance for dimension L in mm:
+1.5 / -2.0

1" clamp according to DIN 32676
1.4404 (316/316L): order code for "Process connection", option KDW

DN [mm]	A [mm]	B [mm]	L [mm]
8	34.0	16	229
15	34.0	16	273
25	50.5	26	324

3-A version ($Ra \leq 0.38 \mu\text{m}/15 \mu\text{in}$) available:
 Order code for "Measuring tube mat., wetted surface", option BF, SK in combination with order code for "Additional approval", option LP

Tri-clamp

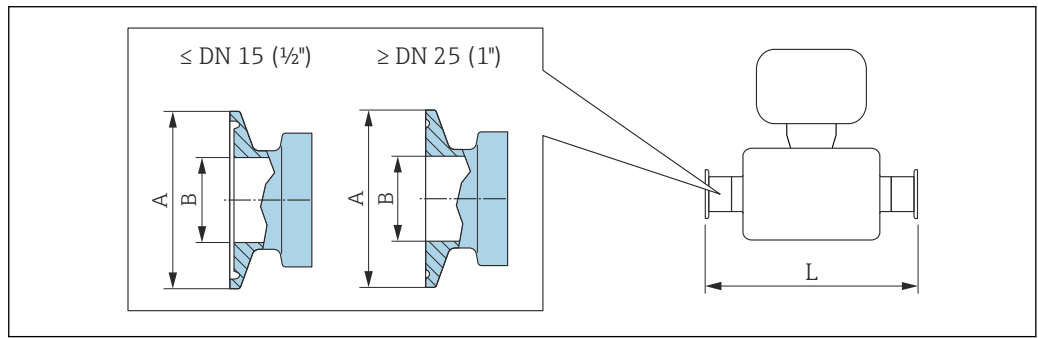

A0052377

i Length tolerance for dimension L in mm:
 +1.5 / -2.0

1/2" Tri-Clamp
1.4435 (316L): order code for "Process connection", option FBW
 Suitable for piping according to DIN 11866 series C

DN [mm]	A [mm]	B [mm]	L [mm]
1	25	9.4	192
2	25	9.4	269
4	25	9.4	315

3-A version available ($Ra \leq 0.76 \mu\text{m}/30 \mu\text{in}$, $Ra \leq 0.38 \mu\text{m}/15 \mu\text{in}$):
 Order code for "Measuring tube mat., wetted surface", option BB, BF in combination with order code for "Additional approval", option LP

1/2" Tri-Clamp BS4825-3
1.4404 (316/316L): order code for "Process connection", option FDW
 Suitable for piping according to DIN 11866 series C

DN [mm]	A [mm]	B [mm]	L [mm]
8	25	9.5	229
15	25	9.5	273

3-A version available ($Ra \leq 0.76 \mu\text{m}/30 \mu\text{in}$, $Ra \leq 0.38 \mu\text{m}/15 \mu\text{in}$):
 Order code for "Measuring tube mat., wetted surface", option BB, BF, SJ, SK in combination with order code for "Additional approval", option LP

3/4" Tri-Clamp
1.4404 (316/316L): order code for "Process connection", option FWW
 Suitable for piping according to DIN 11866 series C

DN [mm]	A [mm]	B [mm]	L [mm]
8	25.0	15.75	229
15	25.0	15.75	273

3-A version available ($Ra \leq 0.76 \mu\text{m}/30 \mu\text{in}$, $Ra \leq 0.38 \mu\text{m}/15 \mu\text{in}$):
 Order code for "Measuring tube mat., wetted surface", option BB, BF, SJ, SK in combination with order code for "Additional approval", option LP

1" Tri-Clamp
1.4404 (316/316L): order code for "Process connection", option FTS
 Suitable for piping according to DIN 11866 series C

DN [mm]	A [mm]	B [mm]	L [mm]
8	50.4	22.1	229
15	50.4	22.1	273
25	50.4	22.1	324
40	50.4	34.8	456

3-A version available ($Ra \leq 0.76 \mu\text{m}/30 \mu\text{in}$, $Ra \leq 0.38 \mu\text{m}/15 \mu\text{in}$):
 Order code for "Measuring tube mat., wetted surface", option BB, BF, SJ, SK in combination with order code for "Additional approval", option LP

Threaded adapter

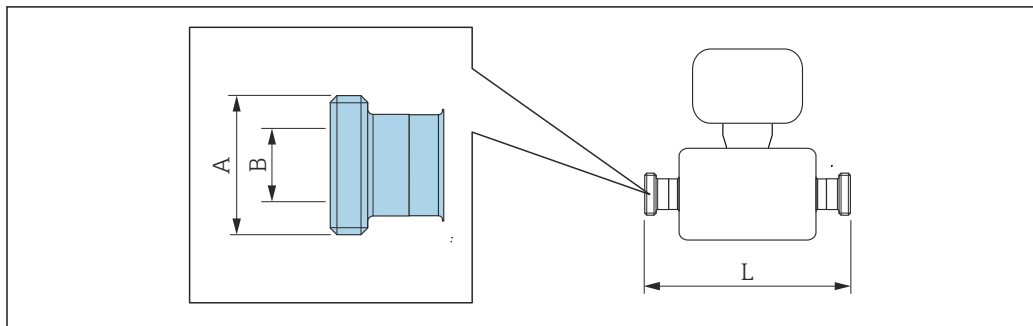

A0015628

i Length tolerance for dimension L in mm:
 +1.5 / -2.0

Threaded adapter as per DIN 11864-1 Form A
1.4404 (316/316L): order code for "Process connection", option FLW
 Suitable for piping according to DIN 11866 series A

DN [mm]	A [mm]	B [mm]	L [mm]
8	Rd 28 × 1/8"	10	229
15	Rd 34 × 1/8"	16	273
25	Rd 52 × 1/6"	26	324
40	Rd 65 × 1/6"	38	456

3-A version available ($Ra \leq 0.76 \mu\text{m}/30 \mu\text{in}$, $Ra \leq 0.38 \mu\text{m}/15 \mu\text{in}$):
 Order code for "Measuring tube mat., wetted surface", option BB, BF, SJ, SK in combination with order code for "Additional approval", option LP

Threaded adapter as per DIN 11851
1.4404 (316/316L): order code for "Process connection", option FMW
 Suitable for piping according to DIN 11866 series A

DN [mm]	A [mm]	B [mm]	L [mm]
8	Rd 34 × 1/8"	16	229
15	Rd 34 × 1/8"	16	273
25	Rd 52 × 1/6"	26	324
40	Rd 65 × 1/6"	38	456

3-A version available (Ra ≤ 0.76 µm/30 µin, Ra ≤ 0.38 µm/15 µin):
 Order code for "Measuring tube mat., wetted surface", option BB, BF, SJ, SK in combination with order code for "Additional approval", option LP

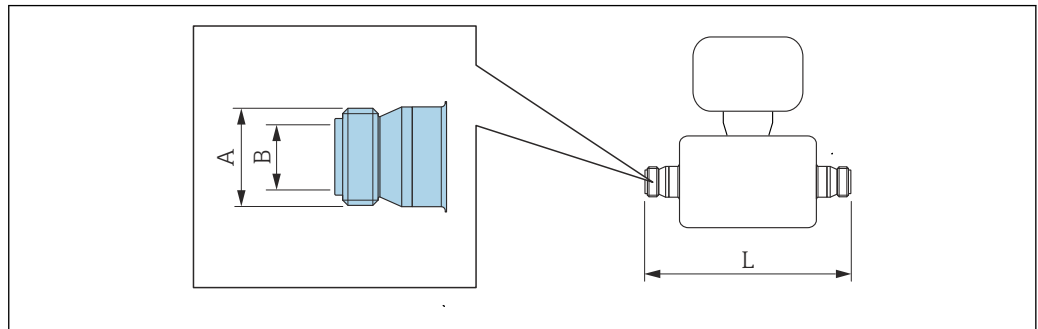

A0015623

 Length tolerance for dimension L in mm:
 +1.5 / -2.0

Threaded adapter as per ISO 2853
1.4404 (316/316L): order code for "Process connection", option JSF
 Suitable for piping according to ISO 2037

DN [mm]	A ¹⁾ [mm]	B [mm]	L [mm]
8	37.13	22.6	229
15	37.13	22.6	273
25	37.13	22.6	324
40	50.68	35.6	456

3-A version available (Ra ≤ 0.76 µm/30 µin, Ra ≤ 0.38 µm/15 µin):
 Order code for "Measuring tube mat., wetted surface", option BB, BF, SJ, SK in combination with order code for "Additional approval", option LP

1) Max. thread diameter according to ISO 2853 Annex A

Accessories

Sensor holder

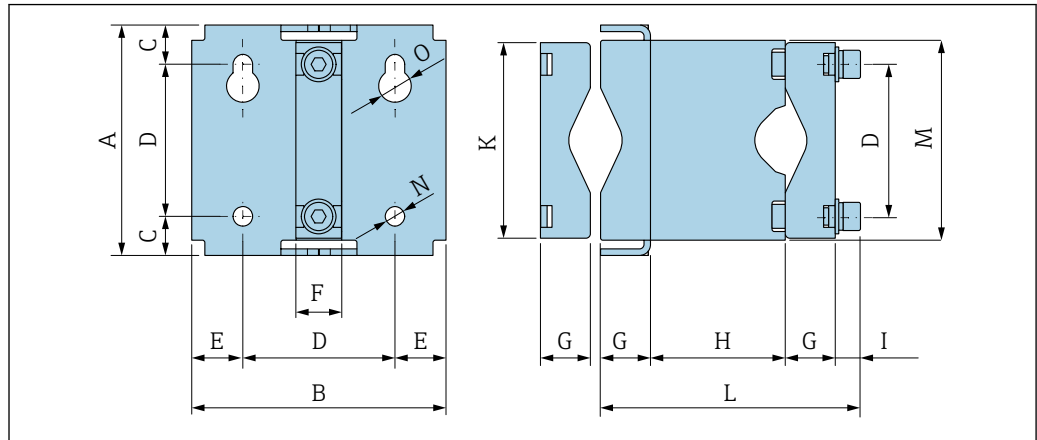

A0036633

A [mm]	B [mm]	C [mm]	D [mm]	E [mm]	F [mm]	G [mm]
106	117	18	70	23.5	21	23

H [mm]	I [mm]	K [mm]	L [mm]	M [mm]	N [mm]	O [mm]
62	12	90	120	92	9	15

Dimensions in US units

Compact version

Order code for "Housing", option B "Compact, stainless", DN 1 to 4 (1/24 to 1/8")

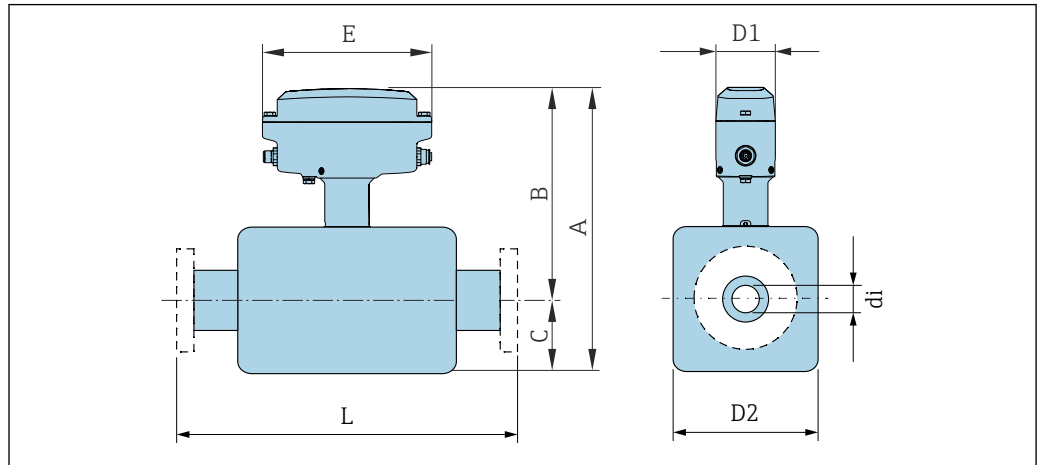

A0053344

DN [in]	A [in]	B [in]	C [in]	D1 [in]	D2 [in]	E [in]	di [in]	L [in]
1/24	9.06	6.93	2.13	2.36	1.34	6.73	0.04	7.56
1/12	10.71	7.80	2.91	2.36	1.89	6.73	0.08	10.59
1/8	11.93	8.39	3.54	2.36	2.01	6.73	0.12	12.40

Order code for "Housing", option B "Compact, stainless", DN 8 to 40 ($\frac{3}{8}$ to 1 $\frac{1}{2}$ ")

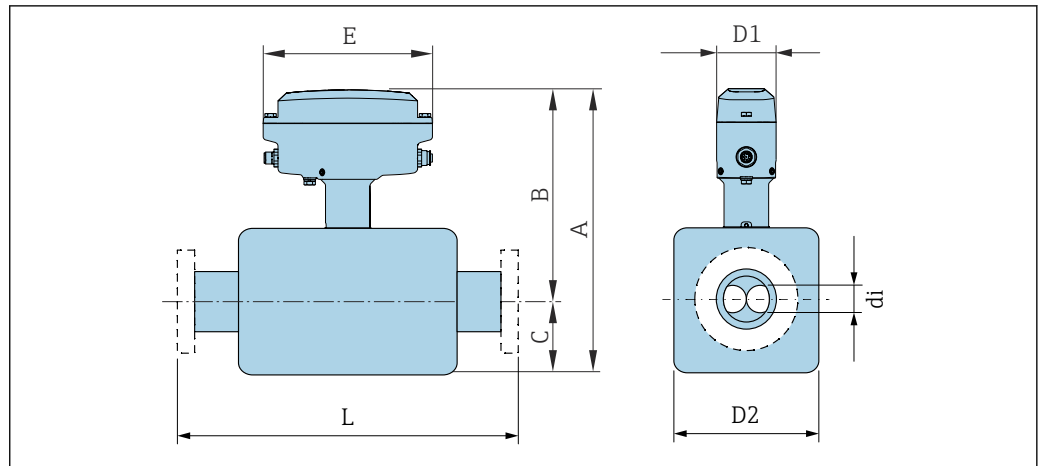

A0052375

DN [in]	A [in]	B [in]	C [in]	D1 [in]	D2 [in]	E [in]	di [in]	L [in]
$\frac{3}{8}$	9.72	6.22	3.54	2.36	1.77	6.73	0.20	¹⁾
$\frac{1}{2}$	10.16	6.22	3.98	2.36	1.77	6.73	0.31	¹⁾
1	10.12	6.10	4.02	2.36	2.01	6.73	0.47	¹⁾
1 $\frac{1}{2}$	11.10	6.34	4.76	2.36	2.56	6.73	0.67	¹⁾

1) Depends on the particular process connection

Clamp connection

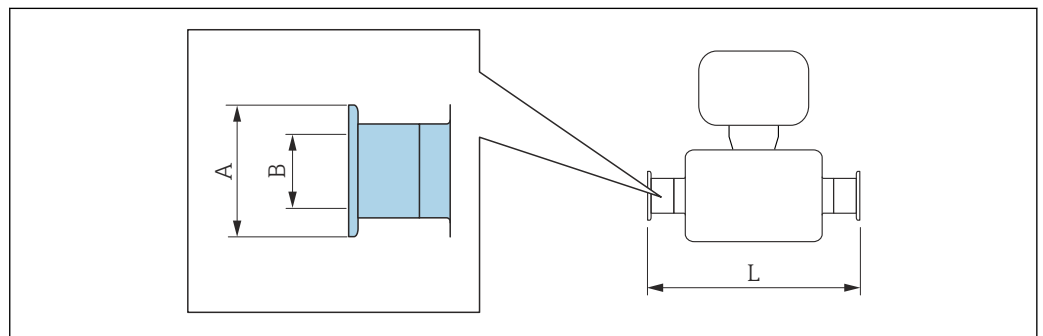

A0015625

 Length tolerance for dimension L in inch:
+0.06 / -0.08

1" clamp according to DIN 32676			
1.4404 (316/316L): order code for "Process connection", option KDW			
DN [in]	A [in]	B [in]	L [in]
$\frac{3}{8}$	1.34	0.63	9.01
$\frac{1}{2}$	1.34	0.63	10.75
1	1.99	1.02	12.76

3-A version (Ra ≤ 0.38 μm/15 μin) available:
Order code for "Measuring tube mat., wetted surface", option BF, SK in combination with order code for "Additional approval", option LP

Tri-clamp

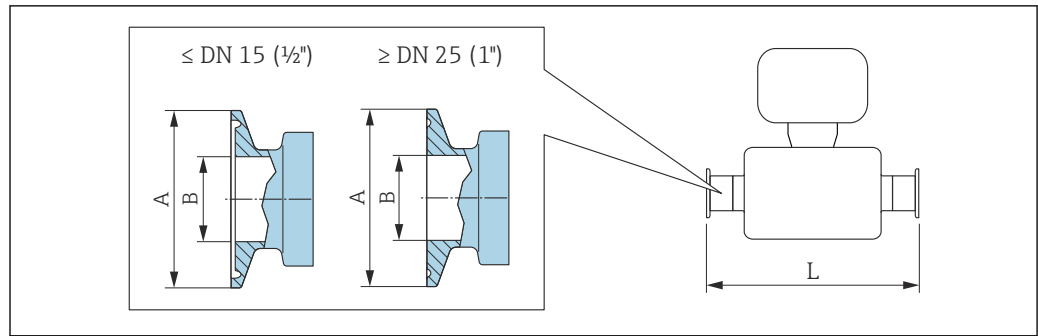

A0052377

i Length tolerance for dimension L in inch:
+0.06 / -0.08

1/2" Tri-Clamp
1.4435 (316L): order code for "Process connection", option **FBW**
 Suitable for piping according to DIN 11866 series C

DN [in]	A [in]	B [in]	L [in]
1/24	0.98	0.37	7.56
1/12	0.98	0.37	10.6
1/8	0.98	0.37	12.4

3-A version available ($R_a \leq 0.76 \mu\text{m}/30 \mu\text{in}$, $R_a \leq 0.38 \mu\text{m}/15 \mu\text{in}$):
 Order code for "Measuring tube mat., wetted surface", option BB, BF in combination with order code for "Additional approval", option LP

1/2" Tri-Clamp BS4825-3
1.4404 (316/316L): order code for "Process connection", option **FDW**
 Suitable for piping according to DIN 11866 series C

DN [in]	A [in]	B [in]	L [in]
3/8	0.98	0.37	9.02
1/2	0.98	0.37	10.80

3-A version available ($R_a \leq 0.76 \mu\text{m}/30 \mu\text{in}$, $R_a \leq 0.38 \mu\text{m}/15 \mu\text{in}$):
 Order code for "Measuring tube mat., wetted surface", option BB, BF, SJ, SK in combination with order code for "Additional approval", option LP

3/4" Tri-Clamp
1.4404 (316/316L): order code for "Process connection", option **FWW**
 Suitable for piping according to DIN 11866 series C

DN [in]	A [in]	B [in]	L [in]
3/8	0.98	0.62	9.02
1/2	0.98	0.62	10.80

3-A version available ($R_a \leq 0.76 \mu\text{m}/30 \mu\text{in}$, $R_a \leq 0.38 \mu\text{m}/15 \mu\text{in}$):
 Order code for "Measuring tube mat., wetted surface", option BB, BF, SJ, SK in combination with order code for "Additional approval", option LP

Threaded adapter

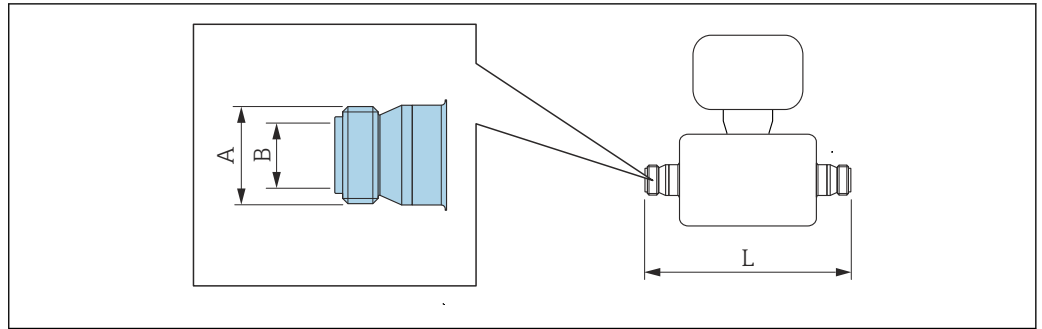

A0015623

 Length tolerance for dimension L in inch:
+0.06 / -0.08

Threaded adapter as per ISO 2853			
1.4404 (316/316L): order code for "Process connection", option JSF			
<i>Suitable for piping according to ISO 2037</i>			
DN [in]	A¹⁾ [in]	B [in]	L [in]
3/8	1.46	0.89	9.02
1/2	1.46	0.89	10.80
1	1.46	0.89	12.80
1 1/2	1.97	1.38	17.95

3-A version available (Ra ≤ 0.76 µm/30 µin, Ra ≤ 0.38 µm/15 µin):
Order code for "Measuring tube mat., wetted surface", option BB, BF, SJ, SK in combination with order code for "Additional approval", option LP

1) Max. thread diameter according to ISO 2853 Annex A

Accessories

Sensor holder

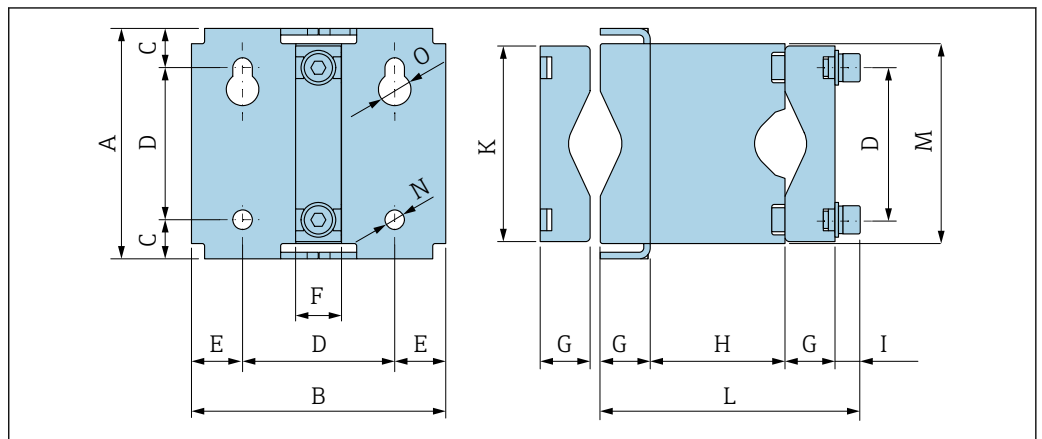

A0036633

A [in]	B [in]	C [in]	D [in]	E [in]	F [in]	G [in]
4.17	4.61	0.71	2.76	0.93	0.83	0.91

H [in]	I [in]	K [in]	L [in]	M [in]	N [in]	O [in]
2.44	0.47	3.54	4.72	3.62	0.35	0.59

Weight

Weight in SI units

DN [mm]	Weight [kg]
1	3.7
2	5.3
4	7.1
8	3.6
15	3.9
25	4.4
40	6.6

Weight in US units

DN [in]	Weight [lbs]
1/24	8.2
1/12	11.7
1/8	15.7
3/8	7.9
1/2	8.6
1	9.7
1 1/2	14.6

Materials

Transmitter housing

- Acid and alkali-resistant outer surface
- Stainless steel, 1.4409 (CF3M)

Device plug

Electrical connection	Material
M12x1 plug	<ul style="list-style-type: none"> ▪ Socket: Polyamide contact support ▪ Connector: Contact support made of thermoplastic polyurethane (TPU-GF) ▪ Contacts: Gold-plated brass

Sensor housing

Acid and alkali-resistant outer surface

DN 1 to 4 mm (1/24 to 1/8")

Stainless steel, 1.4404 (316/316L)

DN 8 to 40 mm (3/8 to 1 1/2")

Stainless steel 1.4301 (304)

Measuring tubes

DN 1 to 4 mm (1/24 to 1/8")

Stainless steel, 1.4435 (316/316L)

DN 8 to 40 mm (3/8 to 1 1/2")

Stainless steel, 1.4539 (904L)



Process connections

DN 1 to 4 mm (1/24 to 1/8")

1/2" Tri-Clamp:
Stainless steel, 1.4435 (316L)

DN 8 to 40 mm (3/8 to 1 1/2")

All process connections:
Stainless steel, 1.4404 (316/316L)

 Available process connections →  43

Seals

Welded process connections without internal seals

Accessories

Sensor holder

Stainless steel, 1.4404 (316L)

Process connections

Fixed flange

- EN 1092-1 (DIN 2501 / DIN 2512N)
- EN 1092-1 (DIN 2501)

Clamp connections

1" clamp according to DIN 32676

Tri-Clamp

- 1/2" Tri-Clamp
- 1/2" Tri-Clamp BS4825-3
- 3/4" Tri-Clamp
- 1" Tri-Clamp

Threaded adapter

- DIN 11864-1 Form A
- DIN 11851
- ISO 2853

 Process connection materials →  43

Surface roughness

All data refer to parts in contact with the medium.

The following surface roughness categories can be ordered:

Category	Method	Option(s) order code "Measuring tube mat., wetted surface"
Not polished	-	SA
Ra ≤ 0.76 µm (30 µin) ¹⁾	Mechanically polished ²⁾	BB
Ra ≤ 0.76 µm (30 µin) ¹⁾	Mechanically polished, welds in as welded condition	SJ
Ra ≤ 0.38 µm (15 µin) ¹⁾	Mechanically polished ²⁾	BF
Ra ≤ 0.38 µm (15 µin) ¹⁾	Mechanically polished, welds in as welded condition	SK

1) Ra according to ISO 21920

2) Excludes inaccessible weld seams between pipe and manifold

Operability

Languages

Can be operated in the following languages:
Via "FieldCare", "DeviceCare" operating tool: English, German, French, Spanish, Italian, Chinese, Japanese

Local operation

This device cannot be operated locally using a display or operating elements.

IO-Link

 The device-specific parameters are configured via IO-Link. There are specific configuration or operating programs from different manufacturers available to the user for this purpose. The device description file (IODD) is provided for the device.

IO-Link operating concept

Operator-oriented menu structure for user-specific tasks. Efficient diagnostic behavior increases measurement availability:

- Diagnostic messages
- Remedial measures
- Simulation options

IODD download

Two options to download the IODD:

- www.endress.com/download
- <https://ioddfinder.io-link.com/>

www.endress.com/download

1. Select "Device drivers".
2. Select the "IO Device Description (IODD)" entry under "Type".
3. Select "Product root".
4. Click "Search".

↳ A list of search results is displayed.

Select the appropriate version and download.

<https://ioddfinder.io-link.com/>

1. Enter "Endress" as the manufacturer and select.
 2. Select product name.
- ↳ A list of search results is displayed.

Select the appropriate version and download.

Remote operation

Using service adapter and Commubox FXA291

Operation and configuration can be performed using the Endress+Hauser FieldCare or DeviceCare service and configuration software.

The device is connected to the USB port of the computer via the service adapter and Commubox FXA291.

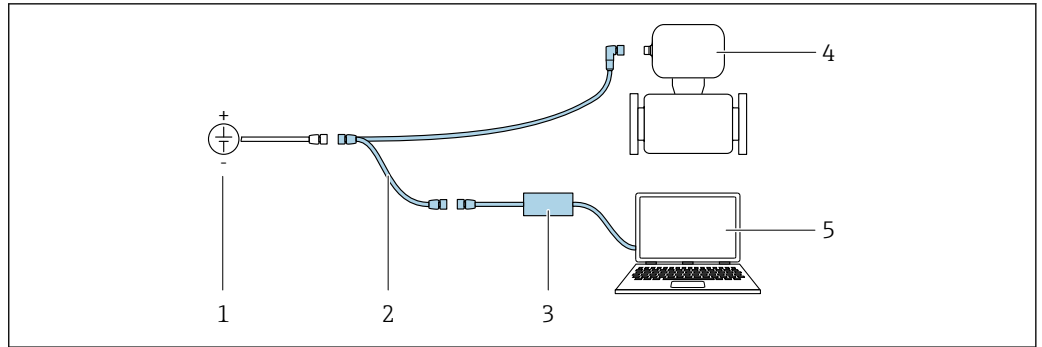

A0032567

- 1 Supply voltage 24 V DC
- 2 Service adapter
- 3 Commubox FXA291
- 4 Dosimass
- 5 Computer with "FieldCare" or "DeviceCare" operating tool

i The service adapter, cable and Commubox FXA291 are not included in the delivery. These components can be ordered as accessories → 47.

Certificates and approvals

Current certificates and approvals for the product are available at www.endress.com on the relevant product page:

1. Select the product using the filters and search field.
2. Open the product page.
3. Select **Downloads**.

CE mark	<p>The device meets the legal requirements of the applicable EU Directives. These are listed in the corresponding EU Declaration of Conformity along with the standards applied.</p> <p>Endress+Hauser confirms successful testing of the device by affixing to it the CE mark.</p>
UKCA marking	<p>The device meets the legal requirements of the applicable UK regulations (Statutory Instruments). These are listed in the UKCA Declaration of Conformity along with the designated standards. By selecting the order option for UKCA marking, Endress+Hauser confirms a successful evaluation and testing of the device by affixing the UKCA mark.</p> <p>Contact address Endress+Hauser UK: Endress+Hauser Ltd. Floats Road Manchester M23 9NF United Kingdom www.uk.endress.com</p>
RCM marking	<p>The measuring system meets the EMC requirements of the "Australian Communications and Media Authority (ACMA)".</p>
cULus listed	<p>The device is UL-listed in the product category "Process Control Equipment, Electrical".</p>
Ex approval	<p>The measuring device is certified for use in hazardous areas and the relevant safety instructions are provided in the separate "Safety Instructions" (XA) document. Reference is made to this document on the nameplate.</p> <p>i The separate Ex documentation (XA) containing all the relevant explosion protection data is available from your Endress+Hauser sales center.</p> <p>ATEX, IECEx</p> <p>Currently, the following versions for use in hazardous areas are available:</p>

Ex ec

Category (ATEX)	Type of protection
II3G	Ex ec IIC T5 to T1 Gc

cULus

Currently, the following versions for use in hazardous areas are available:



Class I Division 2 Groups ABCD

Hygienic compatibility

- 3-A approval
 - Only measuring instruments with the order code for "Additional approval", option LP "3A" have 3-A approval.
 - The 3-A approval refers to the measuring instrument.
 - When installing the measuring instrument, ensure that no liquid can accumulate on the outside of the measuring instrument.
 - Accessories (e.g. sensor retainer) must be installed in accordance with the 3-A Standard. Each accessory can be cleaned. Disassembly may be necessary under certain circumstances.
 - EHEDG-tested ²⁾

Only devices with the order code for "Additional approval", option LT "EHEDG" have been tested and meet the requirements of the EHEDG.

To meet the requirements for EHEDG certification, the device must be used with process connections in accordance with the EHEDG position paper entitled "Easy cleanable Pipe couplings and Process connections" (www.ehedg.org).

To meet the requirements for EHEDG certification, the device must be installed in a position that ensures drainability.
 - Food Contact Materials Regulation (EC) 1935/2004
-  Observe the special installation instructions →  26

Pharmaceutical compatibility

- FDA 21 CFR 177
- USP <87>
- USP <88> Class VI 121 °C
- TSE/BSE Certificate of Suitability
- cGMP

Devices with the order code for "Test, certificate", option JG "Conformity with cGMP-derived requirements, declaration" comply with the requirements of cGMP with regard to the surfaces of parts in contact with the medium, design, FDA 21 CFR material conformity, USP Class VI tests and TSE/BSE conformity.

A serial number-specific declaration is generated.

Pressure Equipment Directive

The measuring devices can be ordered with or without PED or PESR. If a device with PED or PESR is required, this must be ordered explicitly. For devices with nominal diameters less than or equal to DN 25 (1"), this is neither possible nor necessary. A UK order option must be selected for PESR under the order code for "Approvals".

2) DN 8 to 40 (3/8 to 1 1/2")

- With the marking
 - a) PED/G1/x (x = category) or
 - b) PESR/G1/x (x = category)
 on the sensor nameplate, Endress+Hauser confirms compliance with the "Essential Safety Requirements"
 - a) specified in Annex I of the Pressure Equipment Directive 2014/68/EU or
 - b) Schedule 2 of Statutory Instruments 2016 No. 1105.
- Devices bearing this marking (PED or PESR) are suitable for the following types of medium:
 - Media in Group 1 and 2 with a vapor pressure greater than, or smaller and equal to 0.5 bar (7.3 psi)
 - Unstable gases
- Devices not bearing this marking (without PED or PESR) are designed and manufactured according to sound engineering practice. They meet the requirements of
 - a) Art. 4 Para. 3 of the Pressure Equipment Directive 2014/68/EU or
 - b) Part 1, Para. 8 of Statutory Instruments 2016 No. 1105.
 The scope of application is indicated
 - a) in diagrams 6 to 9 in Annex II of the Pressure Equipment Directive 2014/68/EU or
 - b) Schedule 3, Para. 2 of Statutory Instruments 2016 No. 1105.

External standards and guidelines

- EN 60529
Degrees of protection provided by enclosure (IP code)
- EN 61010-1
Safety Requirements for Electrical Equipment for Measurement, Control and Laboratory Use
- GB 30439.5
Safety requirements for industrial automation products - Part 5: Flowmeter safety requirements
- EN 61326-1/-2-3
EMC requirements for electrical equipment for measurement, control and laboratory use
- CAN/CSA C22.2 No. 61010-1-12
Safety Requirements for Electrical Equipment for Measurement, Control and Laboratory Use, Part 1: General Requirements
- ANSI/ISA-61010-1 (82.02.01)
Safety Requirements for Electrical Equipment for Measurement, Control and Laboratory Use – Part 1: General Requirements

Additional certification

CRN approval

Some device versions have CRN approval. A CRN-approved process connection with a CSA approval must be ordered for a CRN-approved device.

Ordering information

Detailed ordering information is available from your nearest sales organization www.addresses.endress.com or in the Product Configurator at www.endress.com:

1. Select the product using the filters and search field.
2. Open the product page.
3. Select **Configuration**.





Product Configurator - the tool for individual product configuration



- Up-to-the-minute configuration data
- Depending on the device: direct input of information specific to the measuring point, such as the measuring range or operating language
- Automatic verification of exclusion criteria
- Automatic creation of the order code and its breakdown in PDF or Excel output format
- Ability to order directly in the Endress+Hauser Online Shop

Accessories

Various accessories, which can be ordered with the device or subsequently from Endress+Hauser, are available for the device. Detailed information on the order code in question is available from your

local Endress+Hauser sales center or on the product page of the Endress+Hauser website:
www.endress.com.

Device-specific accessories	Accessories	Description
	Sensor holder	For wall, tabletop and pipe mounting.  Order number: 71392563  Installation Instructions EA01195D

Communication-specific accessories	Accessory	Description
	FieldCare	FDT-based plant asset management tool from Endress+Hauser. It can configure all smart field units in your system and helps you manage them. By using the status information, it is also a simple but effective way of checking their status and condition.  Operating Instructions BA00027S and BA00059S
	DeviceCare	Tool to connect and configure Endress+Hauser field devices.  Innovation brochure IN01047S
	Commubox FXA291	Connects Endress+Hauser field devices with a CDI interface (= Endress+Hauser Common Data Interface) and the USB port of a computer or laptop.  Technical Information TI00405C
	Adapter connection	Adapter connections for installation on other electrical connections: Adapter FXA291 (order number: 71035809)

Service-specific accessories	Accessories	Description
	Applicator	Software for selecting and sizing Endress+Hauser measuring instruments: <ul style="list-style-type: none"> ▪ Choice of measuring instruments for industrial requirements ▪ Calculation of all the necessary data for identifying the optimum flowmeter: e.g. nominal diameter, pressure loss, flow velocity and measurement accuracy. ▪ Graphic display of the calculation results ▪ Determination of the partial order code, administration, documentation and access to all project-related data and parameters over the entire life cycle of a project. Applicator is available: Via the Internet: https://portal.endress.com/webapp/applicator
	Commubox FXA291	Connects Endress+Hauser field devices with a CDI interface (= Endress+Hauser Common Data Interface) and the USB port of a computer or laptop.  Technical Information TI00405C

Documentation

-  For an overview of the scope of the associated Technical Documentation, refer to the following:
 - *Device Viewer* (www.endress.com/deviceviewer): Enter the serial number from the nameplate
 - *Endress+Hauser Operations app*: Enter serial number from nameplate or scan matrix code on nameplate.

Standard documentation

-  Additional information on semi-standard options is available in the associated Special Documentation in the TSP database.

Brief Operating Instructions

Measuring instrument	Documentation code
Dosimass	KA01688D

Operating Instructions

Measuring instrument	Documentation code		
	Pulse/frequency/status output Option AA	IO-Link Option FA	Modbus RS485 Option MD
Dosimass	BA02346D	BA02330D	BA02347D

Description of Device Parameters

Measuring instrument	Documentation code		
	Pulse/frequency/status output Option AA	IO-Link Option FA	Modbus RS485 Option MD
Dosimass	GP01219D	GP01216D	GP01220D

**Supplementary device-
dependent documentation**

Safety instructions

Contents	Documentation code
ATEX Ex ec	XA03257D
UL Class I, Division 2	XA03263D
UKEX Ex ec	XA03264D

Special documentation

Contents	Documentation code
IO-Link	SD03250D

Registered trademarks

Modbus®

Registered trademark of SCHNEIDER AUTOMATION, INC.

IO-Link®

Is a registered trademark. It may only be used in conjunction with products and services by members of the IO-Link Community or by non-members who hold an appropriate license. For more specific guidelines on use, refer to the IO-Link Community rules on: www.io-link.com.

TRI-CLAMP®

Registered trademark of Ladish & Co., Inc., Kenosha, USA





www.addresses.endress.com
