

Brief Operating Instructions Liquiphant FTL63 Density with Density Calculator QML51

Vibronic

Density measurement for liquids



These Brief Operating Instructions are not a substitute for the Operating Instructions. For further information on the product, see:

- www.endress.com/deviceviewer
- Smartphone/tablet: Endress+Hauser Operations app



1 About this document

1.1 Document function

The Brief Operating Instructions contain all the essential information from incoming acceptance to initial commissioning.

1.2 Symbols

1.2.1 Safety symbols

DANGER

This symbol alerts you to a dangerous situation. Failure to avoid this situation will result in serious or fatal injury.

WARNING

This symbol alerts you to a potentially dangerous situation. Failure to avoid this situation can result in serious or fatal injury.

CAUTION

This symbol alerts you to a potentially dangerous situation. Failure to avoid this situation can result in minor or medium injury.

NOTICE

This symbol alerts you to a potentially harmful situation. Failure to avoid this situation can result in damage to the product or something in its vicinity.

1.2.2 Electrical symbols

 Ground connection

Grounded clamp, which is grounded via a grounding system.

 Protective earth (PE)

Ground terminals, which must be grounded prior to establishing any other connections. The ground terminals are located on the inside and outside of the device.

1.2.3 Tool symbols

 Flat-blade screwdriver

 Allen key

 Open-ended wrench

1.2.4 Symbols for certain types of Information

 Permitted

Procedures, processes or actions that are permitted.

 Forbidden

Procedures, processes or actions that are forbidden.

 Tip

Indicates additional information

 Reference to documentation

 Reference to another section

[1.](#), [2.](#), [3.](#) Series of steps

1.2.5 Symbols in graphics

A, B, C ... View

1, 2, 3 ... Item numbers

 Hazardous area

 Safe area (non-hazardous area)

1.3 Documentation

 For an overview of the scope of the associated Technical Documentation, refer to the following:

- *Device Viewer* (www.endress.com/deviceviewer): Enter the serial number from the nameplate
- *Endress+Hauser Operations app*: Enter serial number from nameplate or scan matrix code on nameplate.

1.3.1 Standard documentation

Document type: Operating Instructions (BA)

Installation and initial commissioning – contains all the functions in the operating menu that are needed for a normal measuring task. Functions beyond this scope are not included.

Document type: Brief Operating Instructions (KA)

Quick guide to the first measured value – includes all essential information from incoming acceptance to electrical connection.

Document type: Safety Instructions, certificates

Depending on the approval, Safety Instructions are also supplied with the device, e.g. XA. This documentation is an integral part of the Operating Instructions.

The nameplate indicates the Safety Instructions (XA) that are relevant to the device.

1.3.2 Supplementary device-dependent documentation

Operating instructions

BA02545S: Density Computer QML51

Special Documentation

- BA02545S: Density Calculator QML51
- BA02600F: FTL63 Density with Density Calculator QML51
- SD03498S: OPC UA server
- SD03501S: Modbus TCP server
- SD01622P: Weld-in adapter (installation instructions)
- TI00426F: Weld-in adapters, process adapters and flanges (overview)

1.4 Registered trademarks

Modbus®

Registered trademark of SCHNEIDER AUTOMATION, INC.

OPC UA

Registered trademark of the OPC Foundation, Scottsdale, Arizona, USA

HART®

Registered trademark of the FieldComm Group, Austin, Texas, USA

2 Basic safety instructions

2.1 Requirements for the personnel

The personnel must fulfill the following requirements for its tasks:

- ▶ Trained, qualified specialists must have a relevant qualification for this specific function and task.
- ▶ Are authorized by the plant owner/operator.
- ▶ Are familiar with federal/national regulations.
- ▶ Before starting work, read and understand the instructions in the manual and supplementary documentation as well as the certificates (depending on the application).
- ▶ Follow instructions and comply with basic conditions.

2.2 Intended use

The device described in this manual is intended only for the level measurement of liquids.

Do not exceed or drop below the relevant limit values for the device

 See the Technical Documentation

Incorrect use

The manufacturer is not liable for damage caused by improper or non-designated use.

Avoid mechanical damage:

- ▶ Do not touch or clean device surfaces with pointed or hard objects.

Clarification for borderline cases:

- ▶ For special media and fluids for cleaning, Endress+Hauser is glad to provide assistance in verifying the corrosion resistance of fluid-wetted materials, but does not accept any warranty or liability.

Residual risks

Due to the transfer of heat from the process and power dissipation within the electronics, the temperature of the housing may increase to up to 80 °C (176 °F) during operation. When in operation, the sensor can reach a temperature close to the medium temperature.

Danger of burns from contact with surfaces!

- ▶ In the event of elevated fluid temperatures, ensure protection against contact to prevent burns.

2.3 Workplace safety

For work on and with the device:

- ▶ Wear the required personal protective equipment according to federal/national regulations.

2.4 Operational safety

Damage to the device!

- ▶ Operate the device only if it is in proper technical condition, free from errors and faults.
- ▶ The operator is responsible for the trouble-free operation of the device.

Configuration, testing and maintenance work on the device

Process safety may be at risk during configuration, testing and maintenance work on the device.

- ▶ Alternative supervisory measures must be taken to guarantee the operational safety and process safety.

Modifications to the device

Unauthorized modifications to the device are not permitted and can lead to unforeseeable dangers.

- ▶ If modifications are nevertheless required, consult Endress+Hauser.

Repair

To ensure continued operational safety and reliability:

- ▶ Only perform repair work on the device if this is expressly permitted.
- ▶ Observe federal/national regulations pertaining to the repair of an electrical device.
- ▶ Use original spare parts and accessories from Endress+Hauser only.

Hazardous area

To eliminate danger to persons or the facility when the device is used in the hazardous area (e.g. explosion protection):

- ▶ Check the nameplate to verify if the device ordered can be put to its intended use in the hazardous area.
- ▶ Comply with the instructions in the separate supplementary documentation, which is an integral part of this manual.

2.5 Product safety

This state-of-the-art device is designed and tested in accordance with good engineering practice to meet operational safety standards. It left the factory in a condition in which it is safe to operate.

It meets general safety standards and legal requirements. It also complies with the EU directives listed in the device-specific EU declaration of conformity. The manufacturer confirms this by affixing the CE mark.

2.6 IT security

The manufacturer warranty is valid only if the product is installed and used as described in the Operating Instructions. The product is equipped with security mechanisms to protect it against any inadvertent changes to the settings.

IT security measures, which provide additional protection for the product and associated data transfer, must be implemented by the operators themselves in line with their security standards.

3 Product description

Liquiphant FTL63 sensor with electronic insert FEL60D

For measuring the density of liquid media in conjunction with Density Calculator QML51. Also suitable for use in hazardous areas.

3.1 Measuring principle

The measuring system consists of the following main components:

- Liquiphant Density
- Density calculator

In conjunction with the density calculator, the Liquiphant Density measures the density of a Newtonian, purely viscous, liquid in pipes and tanks.

A piezoelectric drive causes the vibrating fork of the Liquiphant Density to vibrate at its resonance frequency. Changes in liquid density cause a change in the resonance frequency of the vibrating fork. As a result, the density of the medium has a direct impact on the resonance frequency of the vibrating fork. This effect is used for density measurement.

In the density calculator, the density of the liquid is calculated from the resonance frequency of the vibrating fork transmitted by the sensor and from stored sensor-specific parameters. To compensate for temperature and pressure influences, additional corresponding sensors can be connected to the density calculator.

3.2 Measuring system

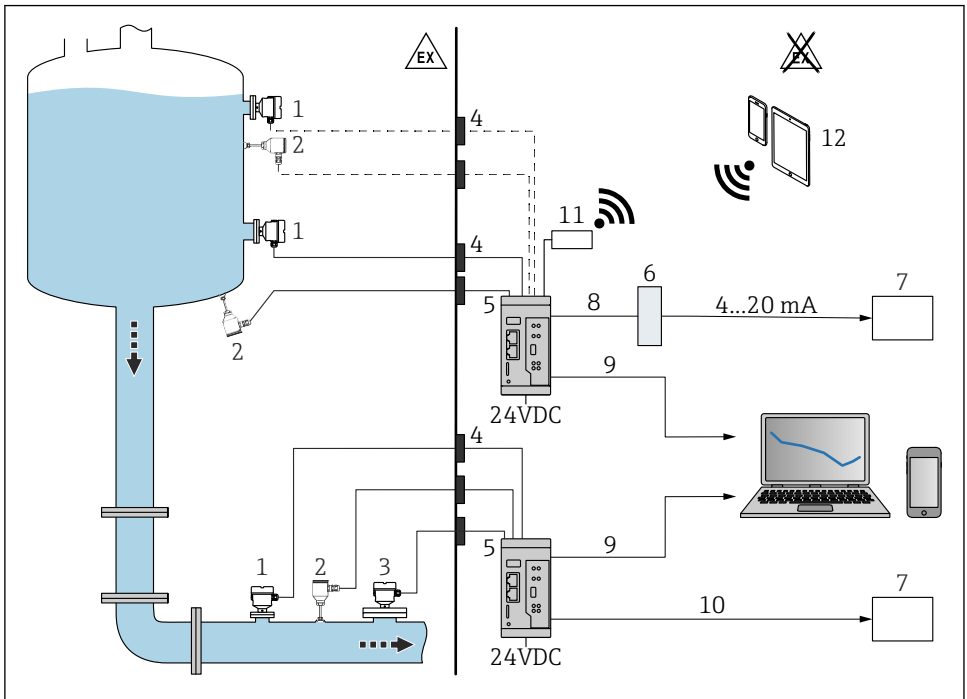

A0059906

1 Density measurement with Density Calculator QML51

- 1 Liquiphant Density with electronic insert FEL60D → pulse output
- 2 Temperature sensor, e.g. 4 to 20 mA output
- 3 Pressure transmitter 4 to 20 mA output; required for pressures above 6 bar (87 psi) or for pressure fluctuations.
- 4 Ex barrier (Liquiphant Density, temperature and/or pressure measuring cell installed in the hazardous area)
- 5 Density Calculator QML51
- 6 Modbus TCP to 4 to 20 mA converter
- 7 Programmable logic controller (PLC)
- 8 Modbus TCP
- 9 Ethernet

- 10 *Modbus TCP or OPC UA*
- 11 *TELTONIKA Router RUT241 (accessory). For a wireless connection.*
- 12 *Mobile devices*



For use in hazardous areas: Ex barrier via RN22 active barrier. The two-channel RN22 active barrier powers analog device circuits and safety equipment up to SIL 2 (SC 3). The intrinsically safe, HART[®] transparent interface provides a reliable connection between the field devices and Density Computer QML51. It is connected to 2-wire/4-wire devices in hazardous areas and provides a second galvanically isolated signal output in accordance with NAMUR NE 175.

In addition to calculating the density of a liquid medium, Density Calculator QML51 can also determine the reference density of the medium and the concentration of a solution, as well as detect up to four different media or an empty pipeline.

In doing so, the density calculator evaluates up to two measuring points and directly supplies connected two-wire transmitters with auxiliary power. This allows the connection of up to two Liquiphant Density sensors and two temperature sensors for compensation of temperature effects in order to calculate reference densities.

For concentration determination, stored standards such as ICUMSA for sugar concentrations, OIML ITS-90 for ethanol, and various preconfigured calculations for electrolyte solutions (according to the Laliberté-Cooper model) can be used.

Specific reference density or concentration tables can be entered manually in the form of linearization tables or imported into the density calculator in standard data formats (e.g., .csv, .xlsx) and used for calculations.

Density and concentration values can be output in various units, for example, SI units, °Baume, °Brix or °API.

Configuration of the QML51 is performed via an integrated web server, which can be accessed via a secure TLS connection using a standard web browser.

For output to a PLC or a SCADA system, the QML51 supports the Ethernet protocols Modbus TCP and OPC UA. If a current signal is required for connection to a PLC, this can be generated via a converter. A converter that generates up to 4 channels with an analog 4 to 20 mA signal from the Modbus TCP protocol is available as an accessory.

3.3 Product design

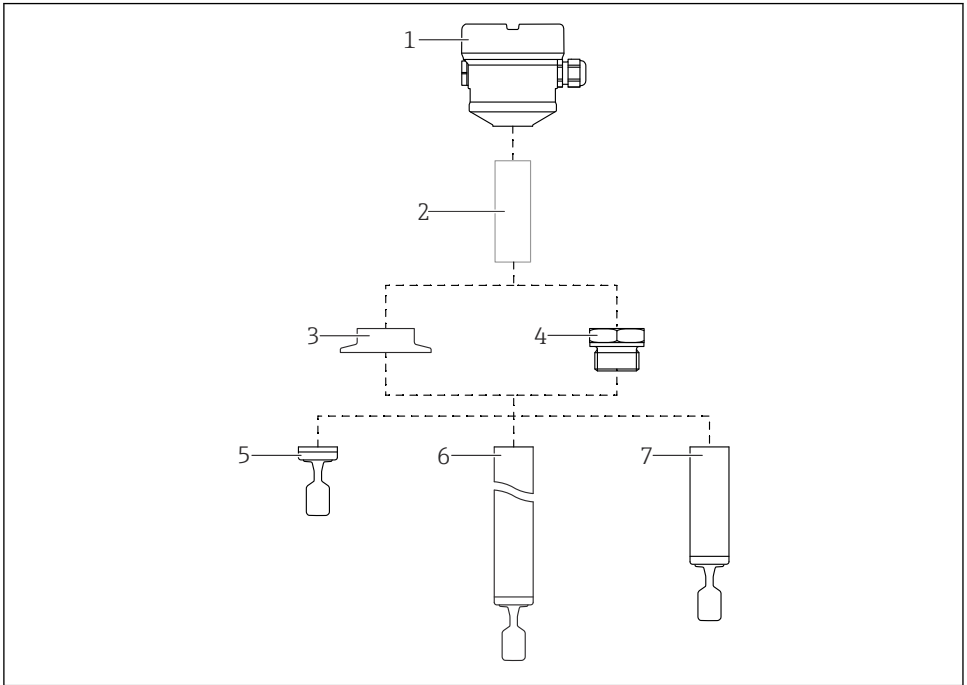

A0052411

2 Liquiphant FTL63 product design

- 1 Housing with electronic insert FEL60D and cover
- 2 Temperature spacer, pressure-tight feedthrough (second line of defense), optional
- 3 Process connection, e.g. clamp/Tri-Clamp
- 4 Process connection, e.g. thread
- 5 Compact probe version with tuning fork
- 6 Pipe extension probe with tuning fork
- 7 Short pipe version of probe with tuning fork

4 Incoming acceptance and product identification

4.1 Incoming acceptance

On receipt of the delivery:

1. Check the packaging for damage.
 - ↳ Report all damage immediately to the manufacturer.
Do not install damaged components.
2. Check the scope of delivery using the delivery note.

3. Compare the data on the nameplate with the order specifications on the delivery note.
4. Check the technical documentation and all other necessary documents, e.g. certificates, to ensure they are complete.



If one of the conditions is not satisfied, contact the manufacturer.

4.2 Product identification

The following options are available for identification of the device:

- Nameplate specifications
- Order code with breakdown of the device features on the delivery note
- Enter the serial numbers from the nameplates in *Device Viewer* (www.endress.com/deviceviewer): all the information about the device is displayed.

4.2.1 Nameplate

The information that is required by law and is relevant to the device is shown on the nameplate, e.g.:

- Manufacturer identification
- Order number, extended order code, serial number
- Technical data, degree of protection
- Firmware version, hardware version
- Approval-specific information
- DataMatrix code (information about the device)

Compare the data on the nameplate with your order.

4.2.2 Manufacturer address

Endress+Hauser SE+Co. KG
Hauptstraße 1
79689 Maulburg, Germany

Place of manufacture: See nameplate.

4.3 Storage and transport

4.3.1 Storage conditions

- Use the original packaging
- Store the device in clean and dry conditions and protect from damage caused by shocks

Storage temperature

Liquiphant FTL63

-40 to +80 °C (-40 to +176 °F)

Density Calculator QML51

-25 to 85 °C (-13 to 185 °F)

Transporting the device

- Transport the device to the measuring point in the original packaging
- Hold the device by the housing, temperature spacer, process connection or extension pipe
- Do not bend, shorten or extend the tuning fork

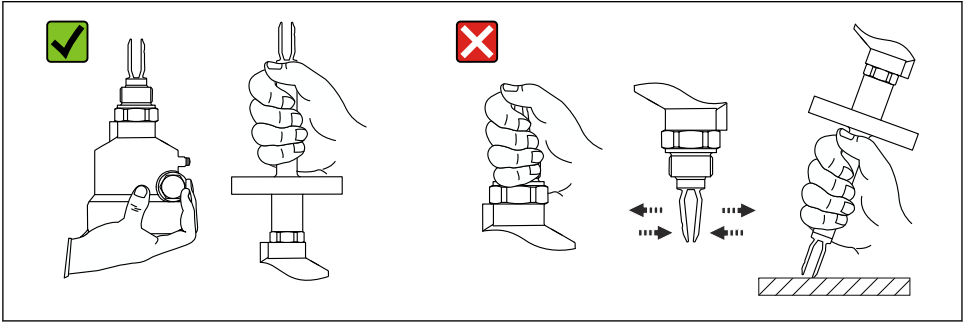

A0034846

3 Handling the device during transport

5 Installation

Mounting instructions

- Any orientation for compact version or version with a pipe length of up to 500 mm (19.7 in) approx.
- Vertical orientation from above for device with long pipe
- Minimum distance between the fork tip and the tank wall or pipe wall: 10 mm (0.39 in)

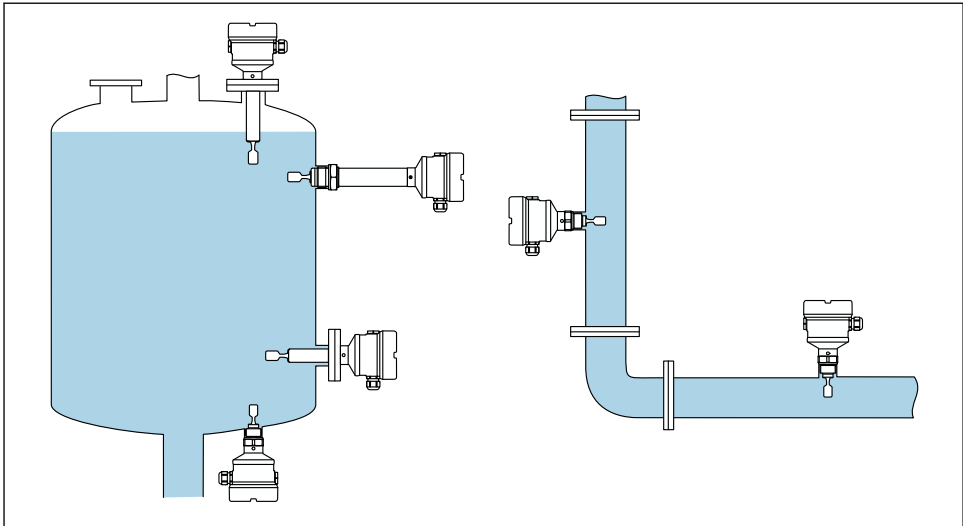

A0039739

4 Installation examples for a vessel, tank or pipe

5.1 Installation requirements

The mounting location must be selected such that the vibrating fork and the membrane are always immersed in the medium.

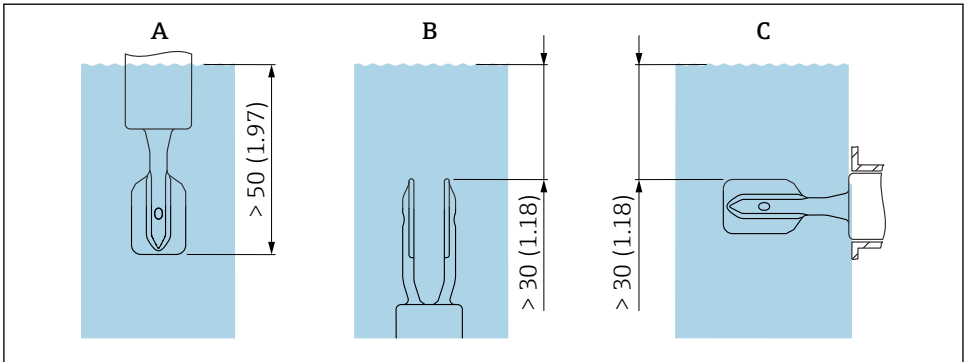

A0039685

5 Unit mm (in)

- A Installation from above
- B Installation from below
- C Installation from the side



- Avoid air bubbles in pipe or nozzle
- Ensure suitable ventilation



Maximum viscosity: 350 mPa·s (3.5 P)

5.1.1 Flow velocity - Installation in piping

Install the tuning fork within the medium flow

- Flow velocity: < 2 m/s (6.56 ft/s) per second
- Prevents the formation of air bubbles (1)

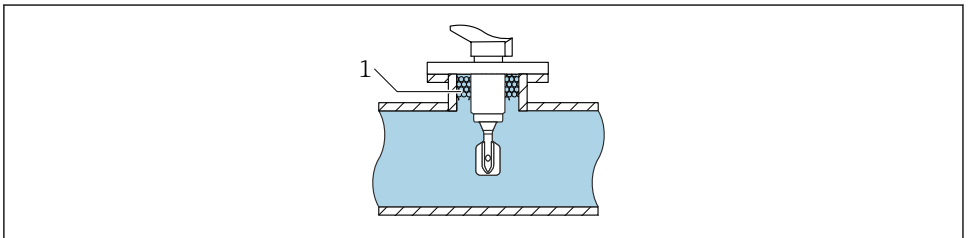

A0039718

6 Installation example in pipes within the media flow

Install the tuning fork away from the direct flow of medium

Flow velocity: < 2 m/s (6.56 ft/s)

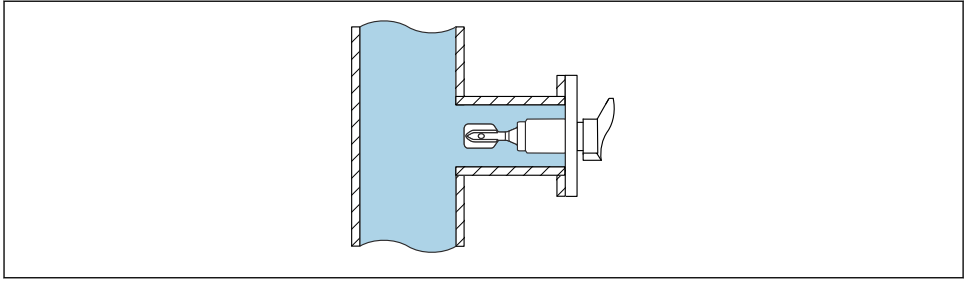

A0039721

7 Installation example in pipes away from the direct flow of medium

5.1.2 Inlet and outlet runs

Inlet run

If possible, install the sensor as far upstream as possible, e.g. valves, T-pieces, elbows, flange elbows, etc.

To comply with the accuracy specification, the inlet run must meet the following requirements:

Inlet run: $\geq 5 \times \text{DN}$ (nominal diameter) - min. 750 mm (29.5 in)

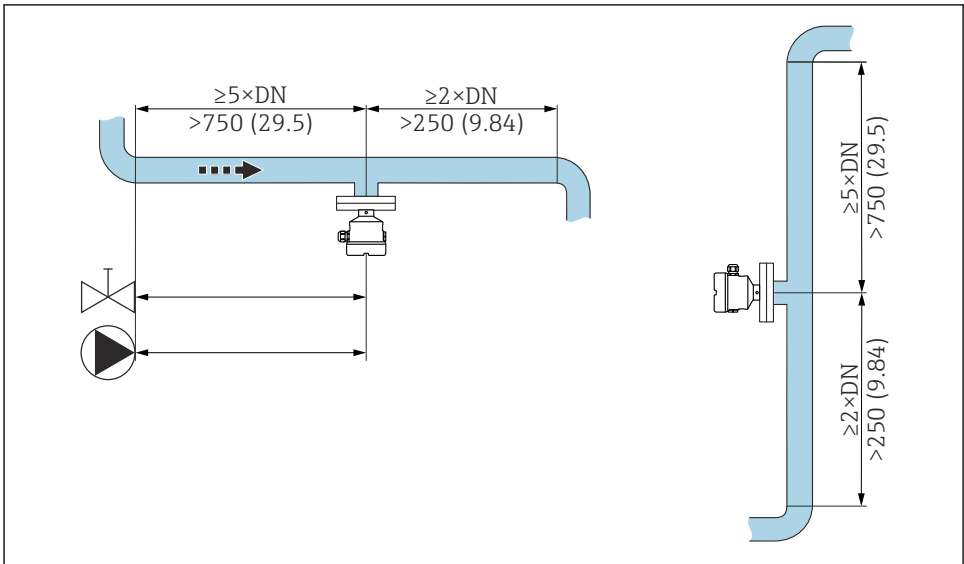

A0039700

8 Installing the inlet run. Unit of measurement mm (in)

Outlet run

To comply with the accuracy specification, the outlet run must meet the following requirements:

Outlet run: $\geq 2x$ DN (nominal diameter) - min. 250 mm (9.84 in)

The pressure and temperature sensor must be installed on the outlet side of the flow direction after the Liquiphant density sensor. When installing pressure and temperature measuring points downstream of the device, make sure the distance between the measuring point and the device is sufficient.

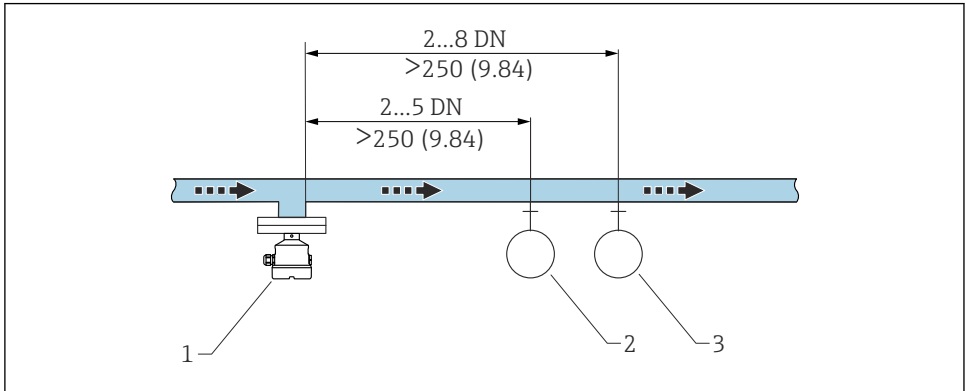

A0039701

 9 *Installing the outlet run. Unit of measurement mm (in)*

- 1 *Liquiphant density sensor*
- 2 *Pressure measuring point*
- 3 *Temperature measuring point*

5.1.3 Correction factor

If the vibration of the vibrating fork is affected by conditions at the mounting location, the measurement result can be adjusted using a correction factor (r).

Standard installation

Correction factor "r" as a function of the height "h", for entry in the Density Computer QML51:

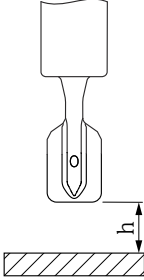
	h	r
 <p>A0039687</p>	12 mm (0.47 in)	1.0026
	14 mm (0.55 in)	1.0016
	16 mm (0.63 in)	1.0011
	18 mm (0.71 in)	1.0008
	20 mm (0.79 in)	1.0006
	22 mm (0.87 in)	1.0005
	24 mm (0.94 in)	1.0004
	26 mm (1.02 in)	1.0004
	28 mm (1.10 in)	1.0004
	30 mm (1.18 in)	1.0003
	32 mm (1.26 in)	1.0003
	34 mm (1.34 in)	1.0002
	36 mm (1.42 in)	1.0001
	38 mm (1.50 in)	1.0001
	40 mm (1.57 in)	1.0000

Installation in a bypass

Correction factor "r" as a function of the internal diameter of bypass "D", for entry in the Density Computer QML51:

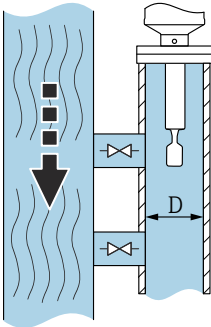
	D	r
 <p>A0039689</p>	<44 mm (1.73 in)	-
	44 mm (1.73 in)	1.0191
	46 mm (1.81 in)	1.0162
	48 mm (1.89 in)	1.0137
	50 mm (1.97 in)	1.0116
	52 mm (2.05 in)	1.0098
	54 mm (2.13 in)	1.0083
	56 mm (2.20 in)	1.0070
	58 mm (2.28 in)	1.0059
	60 mm (2.36 in)	1.0050

	D	r
	62 mm (2.44 in)	1.0042
	64 mm (2.52 in)	1.0035
	66 mm (2.60 in)	1.0030
	68 mm (2.68 in)	1.0025
	70 mm (2.76 in)	1.0021
	72 mm (2.83 in)	1.0017
	74 mm (2.91 in)	1.0014
	76 mm (2.99 in)	1.0012
	78 mm (3.07 in)	1.0010
	80 mm (3.15 in)	1.0008
	82 mm (3.23 in)	1.0006
	84 mm (3.31 in)	1.0005
	86 mm (3.39 in)	1.0004
	88 mm (3.46 in)	1.0003
	90 mm (3.54 in)	1.0003
	92 mm (3.62 in)	1.0002
	94 mm (3.70 in)	1.0002
	96 mm (3.78 in)	1.0001
	98 mm (3.86 in)	1.0001
	100 mm (3.94 in)	1.0001
	>100 mm (3.94 in)	1.0000

Installation in pipe

Correction factor "r" as a function of the internal diameter of pipe "D", for entry in the Density Computer QML51:

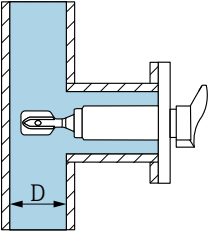
	D	r
	<44 mm (1.73 in)	-
	44 mm (1.73 in)	1.0225
	46 mm (1.81 in)	1.0167
	48 mm (1.89 in)	1.0125
	50 mm (1.97 in)	1.0096
	52 mm (2.05 in)	1.0075
	54 mm (2.13 in)	1.0061
	A0039707	

	D	r
	56 mm (2.20 in)	1.0051
	58 mm (2.28 in)	1.0044
	60 mm (2.36 in)	1.0039
	62 mm (2.44 in)	1.0035
	64 mm (2.52 in)	1.0032
	66 mm (2.60 in)	1.0028
	68 mm (2.68 in)	1.0025
	70 mm (2.76 in)	1.0022
	72 mm (2.83 in)	1.0020
	74 mm (2.91 in)	1.0017
	76 mm (2.99 in)	1.0015
	78 mm (3.07 in)	1.0012
	80 mm (3.15 in)	1.0009
	82 mm (3.23 in)	1.0007
	84 mm (3.31 in)	1.0005
	86 mm (3.39 in)	1.0004
	88 mm (3.46 in)	1.0003
	90 mm (3.54 in)	1.0002
	92 mm (3.62 in)	1.0002
	94 mm (3.70 in)	1.0001
	96 mm (3.78 in)	1.0001
	98 mm (3.86 in)	1.0001
	100 mm (3.94 in)	1.0001
	>100 mm (3.94 in)	1.0000

5.1.4 Preventing buildup



Allow for maintenance intervals if required!

5.1.5 Take clearance into consideration

Allow sufficient space outside the tank for mounting, connection and replacement of the electronic insert.

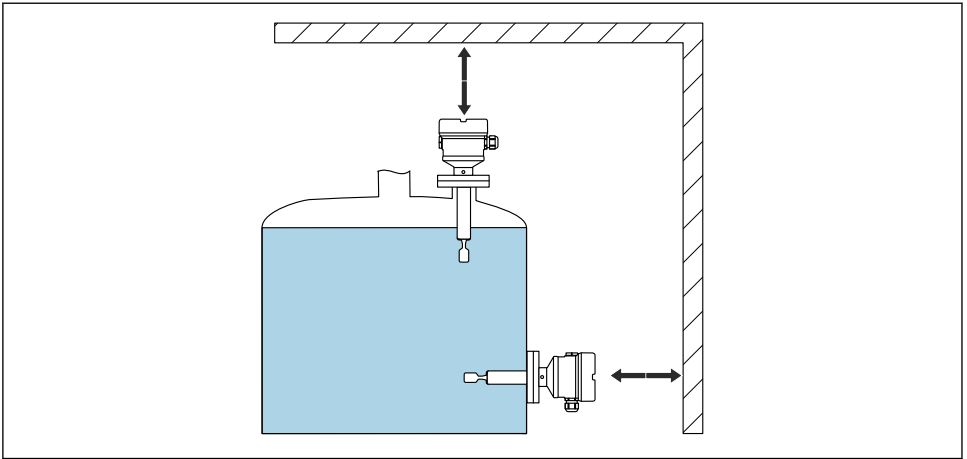

A0039741

☛ 10 Take clearance into consideration

5.1.6 Support the device

Support the device in the event of severe dynamic load. Maximum lateral loading capacity of the pipe extensions and sensors: 75 Nm (55 lbf ft).

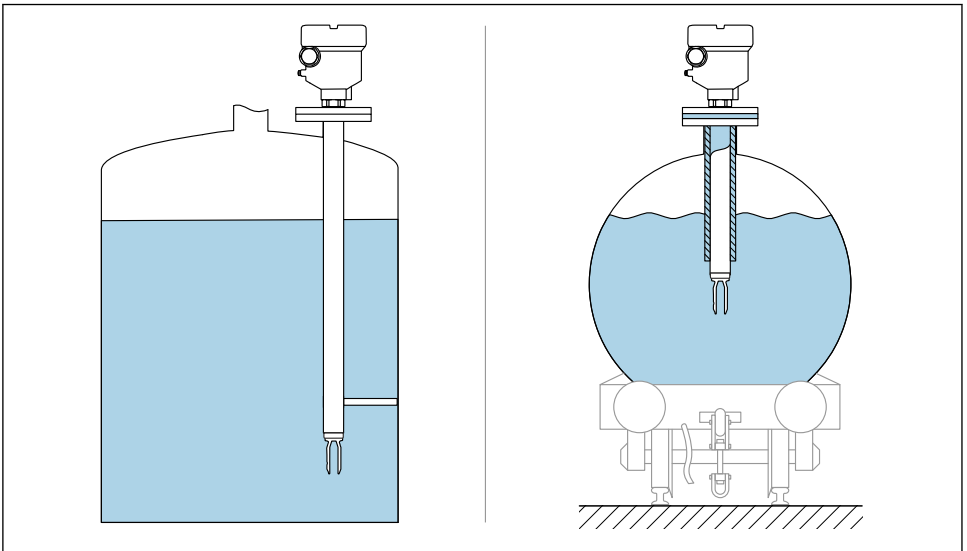

A0039742

☛ 11 Examples of support in the event of dynamic load

5.1.7 Weld-in adapter with leakage hole

Position the weld-in adapter so that the leakage hole points downwards. This allows any leakage to be detected at an early stage, as the escaping medium becomes visible.

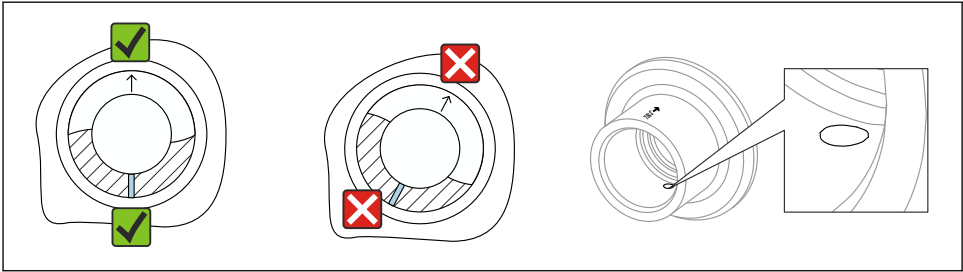

A0039230

 12 *Weld-in adapter with leakage hole*

5.2 Installing the device

5.2.1 Required tool

- Open-ended wrench for sensor installation
- Allen key for housing locking screw

5.2.2 Installation procedure

Align the vibrating fork using the marking

The vibrating fork can be aligned using the marking in such a way that the medium drains off easily and buildup is avoided.

- Markings for threaded connections: Circle (material specification/thread designation opposite)
- Markings for flange or clamp connections: Line or double line



In addition, the threaded connections have a matrix code that is **not** used for alignment.

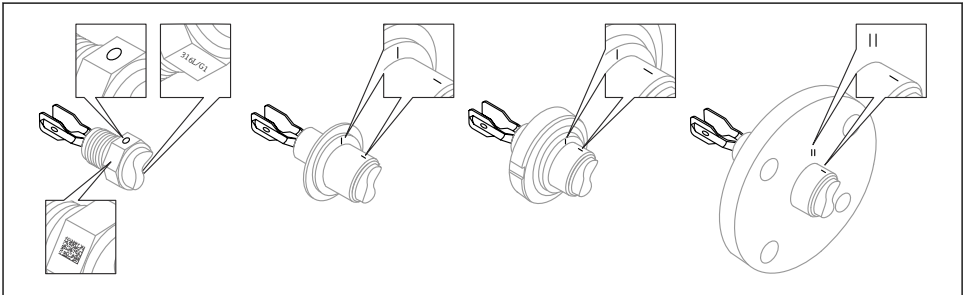

A0039125

 13 *Position of the vibrating fork when installed horizontally in the vessel using the marking*

Installing the device in piping

NOTICE

Incorrect alignment of the tuning fork

Vortices and eddies can falsify the measuring result.

- ▶ Align the tuning fork in the flow direction for internal fixtures in pipes or tanks with an agitator.
- The flow velocity of the medium must not exceed 2 m/s (6.56 ft/s) during operation
- Flow velocity > 2 m/s: Separate the tuning fork from the direct flow of media by using structural features such as a bypass or pipe expansion to reduce the flow velocity to max. 2 m/s (6.56 ft/s)
- The flow will not be significantly impeded if the tuning fork is correctly aligned and the marking is pointing in the direction of flow.
- A marking on the process connection indicates the position of the tuning fork.
Threaded connection = dot on the hexagon head; flange = two lines on the flange.
The marking is visible when installed.

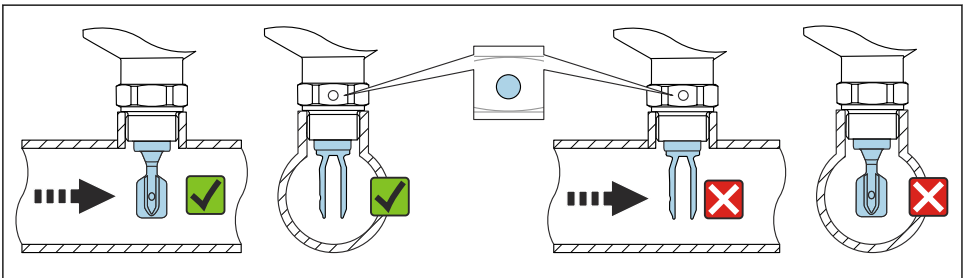

A0034851

14 Installation in pipes (take fork position and marking into consideration)

Screwing in the device

- Turn by the hex bolt only, 15 to 30 Nm (11 to 22 lbf ft)
- Do not turn at the housing!

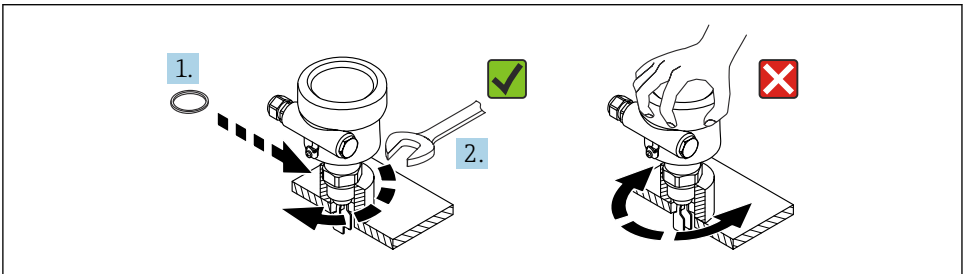

A0034851

15 Screwing in the device

Aligning the cable entry

All housings can be aligned.

Housing without locking screw

The device housing can be rotated up to 350°.

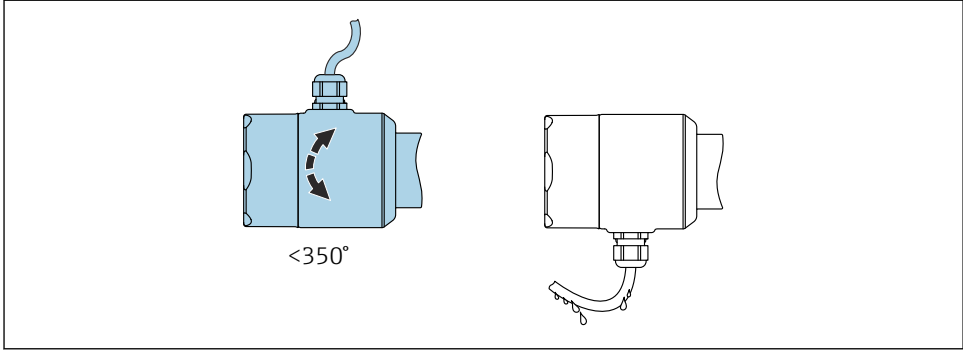

A0052359

 16 Housing without locking screw with drip loop

Housing with locking screw

 In the case of housings with locking screw:

- The housing can be turned and the cable aligned by loosening the locking screw. A cable loop for draining prevents moisture in the housing.
- When the device is delivered from the factory, the locking screw is tightened.

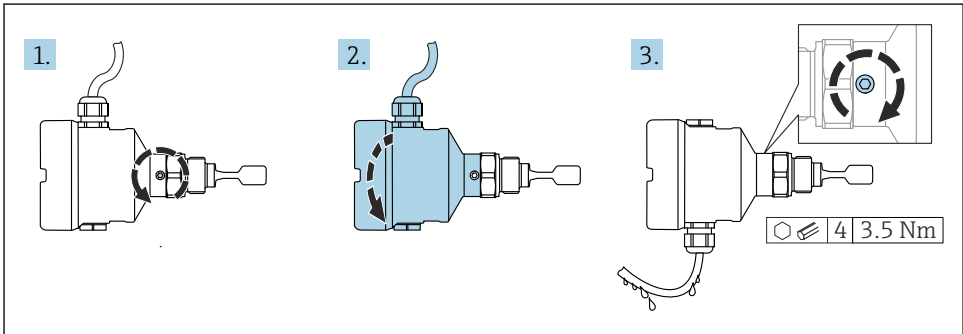

A0037347

 17 Housing with external locking screw and drip loop

1. Loosen the external locking screw (maximum 1.5 turns).
2. Turn the housing and align the cable entry.
3. Tighten the external locking screw.

NOTICE**The housing cannot be unscrewed fully.**

- ▶ Loosen the external locking screw by a maximum of 1.5 turns. If the screw is unscrewed too much or completely (beyond the screw anchor point), small parts (counter disk) can become loose and fall out.
- ▶ Tighten the securing screw (hexagon socket 4 mm (0.16 in)) with maximum 3.5 Nm (2.58 lbf ft)±0.3 Nm (±0.22 lbf ft).

Closing the housing covers

NOTICE**Thread and housing cover damaged from dirt and fouling!**

- ▶ Remove dirt (e.g. sand) on the thread of the covers and housing.
- ▶ If you continue to encounter resistance when closing the cover, check the thread again for fouling.

**Housing thread**

The threads of the electronics and connection compartment can be coated with an anti-friction coating.

The following applies for all housing materials:

✘ Do not lubricate the housing threads.

5.3 Post-mounting check

- Is the device undamaged (visual inspection)?
- Are the measuring point number and labeling correct (visual inspection)?
- Is the device adequately protected from precipitation and direct sunlight?
- Is the device properly secured?
- Does the device comply with the measuring point specifications?

For example:

- Process temperature
- Process pressure
- Ambient temperature
- Measuring range

6 Electrical connection

6.1 Connecting requirements

6.1.1 Cover with securing screw

The cover is locked by a securing screw in devices for use in hazardous areas with certain explosion protection.

NOTICE

If the securing screw is not positioned correctly, the cover cannot provide secure sealing.

- ▶ Open the cover: slacken the screw of the cover lock with a maximum of 2 turns so that the screw does not fall out. Fit the cover and check the cover seal.
- ▶ Close the cover: screw the cover securely onto the housing, making sure that the securing screw is positioned correctly. There should not be any gap between the cover and housing.

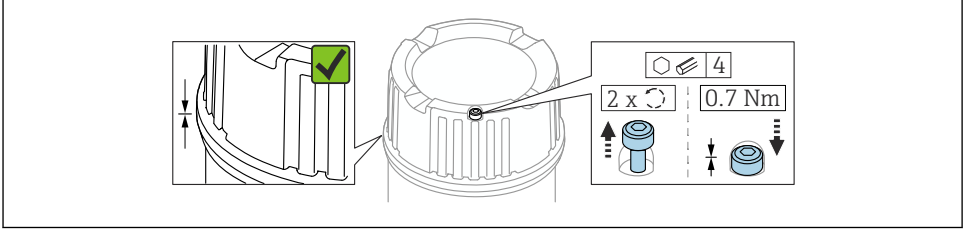

A0039520

 18 Cover with securing screw

6.1.2 Connecting protective earth (PE)

When the device is used in hazardous areas, it must always be included in the potential equalization of the system, irrespective of the operating voltage. This is possible by connecting to the inner or outer protective ground connection (PE).

6.2 Connecting the device



Housing thread

The threads of the electronics and connection compartment can be coated with an anti-friction coating.

The following applies for all housing materials:

 **Do not lubricate the housing threads.**

6.2.1 2-wire density (electronic insert FEL60D) for density measurement

NOTICE

Operation with other switching units is not permitted.

Destruction of electronic components.

- ▶ Do not install the FEL60D electronic insert in devices that were originally used as level switches.

Terminal assignment

The output signal of the density sensor is based on pulse technology. Using this signal, the fork frequency is continuously transmitted to the Density Computer QML51.

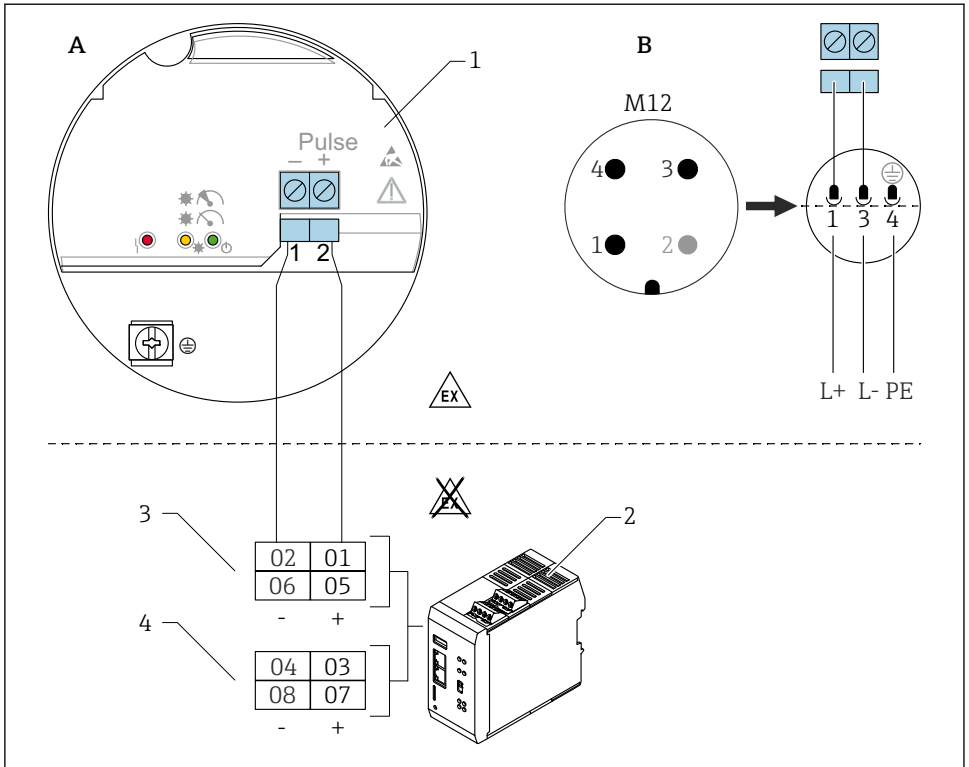

A0059904

19 Connection diagram: connection of electronic insert FEL60D to the Density Computer QML51

- A Connection wiring with terminals
 B Connection wiring with M12 plug in housing as per EN61131-2 standard
 1 Electronic insert FEL60D
 2 Density Computer QML51
 3 Connection options for Liquiphant
 4 Connection options for 4 to 20 mA devices, e.g. temperature measuring device

Supply voltage

The supply voltage is 24 V_{DC} (±20%), only suitable for connecting to Density Calculator QML51.

The device must be powered by a voltage supply categorized as "CLASS 2" or "SELV".

Power consumption

- FTL63 Density: P < 160 mW
- Density Computer QML51: P < 9 W

Current consumption

FTL63 Density: $I < 10 \text{ mA}$

Overvoltage protection

Overvoltage category I

Adjusting Liquiphant with density electronics FEL60D

There are 3 different types of adjustment:

- **Standard adjustment** (as delivered state):
To determine the sensor characteristics, the fork parameters are measured under two conditions (vacuum and a defined water bath). The device-specific parameters determined are supplied with the device in an adjustment report. These parameters must be transferred to the Density Computer QML51.
- **Special adjustment** (select in the Product Configurator):
To determine the sensor characteristics, the fork parameters are measured under three conditions (vacuum and two defined water baths at specified temperatures). The device-specific parameters determined are supplied with the device in an adjustment report. These parameters must be transferred to the Density Computer QML51.
This type of adjustment achieves an even higher level of accuracy.
- **Field adjustment**:
During field adjustment, the density determined by the user is transferred to the Density Computer QML51.

 All the necessary parameters of the Liquiphant Density are documented in the **adjustment report** and in the **sensor pass**.

The documents are included in the scope of delivery.

 Further information and the documentation currently available can be found on the Endress+Hauser website: www.endress.com → Downloads.

Density measurement

The Liquiphant Density measures the density of a liquid medium in pipes and tanks. The device is suitable for all Newtonian (purely viscous) fluids. In addition, the device is also suitable for use in hazardous areas.

 The measurement can be affected by:

- Air bubbles at the sensor
- Sensor not fully covered by medium
- Solid media buildup on the sensor
- High fluid velocity in pipes
- Severe turbulence in the pipe due to inlet and outlet runs that are too short
- Corrosion of the fork
- Non-Newtonian (not purely viscous) behavior of fluids

6.2.2 Connecting the cable

Required tools

- Flat-blade screwdriver (0.6 mm x 3.5 mm) for terminals
- Suitable tool with width across flats AF24/25 (8 Nm (5.9 lbf ft)) for M20 cable gland

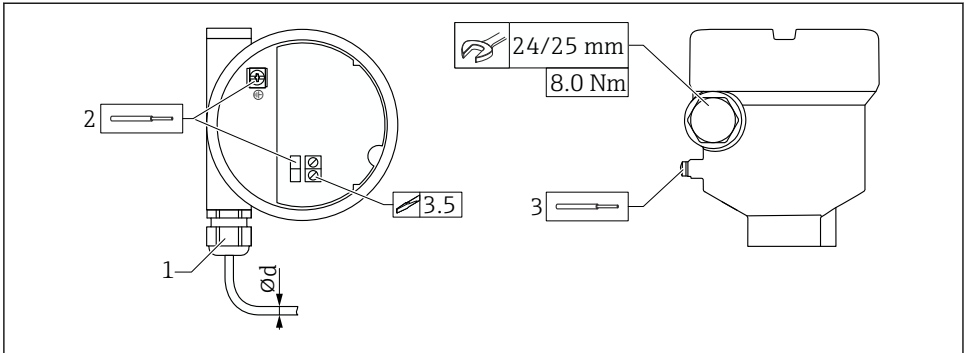

A0018023

20 Example of coupling with cable entry, electronic insert with terminals

- 1 M20 coupling (with cable entry), example
 - 2 Maximum conductor cross-section 2.5 mm^2 (AWG14), ground terminal inside the housing + terminals on the electronics
 - 3 Maximum conductor cross-section 4.0 mm^2 (AWG12), ground terminal on outside of the housing (example: Plastic housing with outer protective ground connection (PE))
- Ød Nickel-plated brass 7 to 10.5 mm (0.28 to 0.41 in)
 Plastic 5 to 10 mm (0.2 to 0.38 in)
 Stainless steel 7 to 12 mm (0.28 to 0.47 in)
 Hygienic stainless steel 7 to 10 mm (0.28 to 0.39 in)



Pay attention to the following when using the M20 coupling

After inserting the cable:

- Counter-tighten the coupling
- Tighten the union nut of the coupling with a torque of 8 Nm (5.9 lbf ft)
- Screw the enclosed coupling into the housing with a torque of 3.75 Nm (2.76 lbf ft)

6.2.3 Post-connection check

- Is the device or cable undamaged (visual inspection)?
- Do the cables used comply with the requirements?
- Do the mounted cables have adequate strain relief?
- Are the cable glands mounted and firmly tightened?
- Does the supply voltage match the information on the nameplate?
- No reverse polarity, is terminal assignment correct?
- If supply voltage is present, is the green LED lit?
- Are all the housing covers installed and tightened?
- Optional: Is the cover tightened with securing screw?

7 Operation options

7.1 Overview of operation options

7.1.1 Operation concept

Operation with the Density Computer QML51 For details, see documentation for the Density Computer QML51.

7.1.2 Elements on the electronic insert

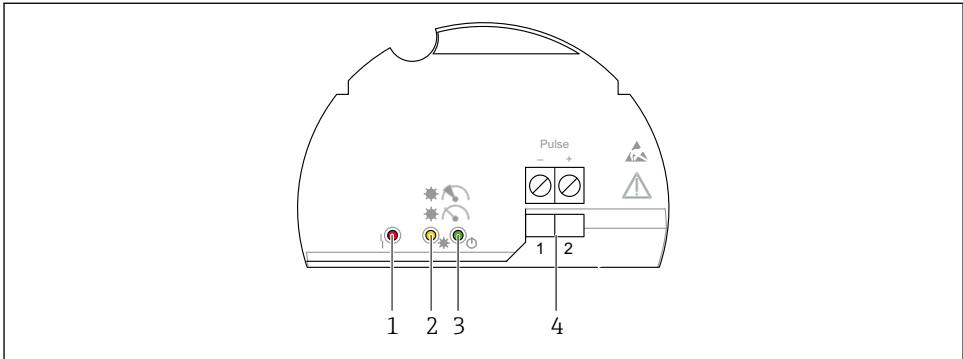

A0039683

21 Electronic insert FEL60D

- 1 LED red, for warning or alarm
- 2 LED yellow, stability of measurement
- 3 LED green, operational status (device is on)
- 4 Pulse output terminals

8 Commissioning

i The contents of this section apply to the Liquiphant.
See also the Operating Instructions for the density calculator: BA02545S.

8.1 Post-installation and function check

Before commissioning the measuring point, check whether the post-installation and post-connection checks have been performed.

- Post-mounting check
- Post-connection check

8.2 Switching on the device

► Switch on

- ↳ The green LED is lit and the yellow LED flashes 2-3 times

The measurement is stable if both LEDs (green and yellow) are then lit.



71758477

www.addresses.endress.com
