



Level



Pressure



Flow



Temperature



Liquid
Analysis



Registration



Systems
Components



Services



Solutions

Functional Safety Manual

Cerabar T PMP131, PMC131, PMP135

Pressure Transducer with 4...20 mA output signal

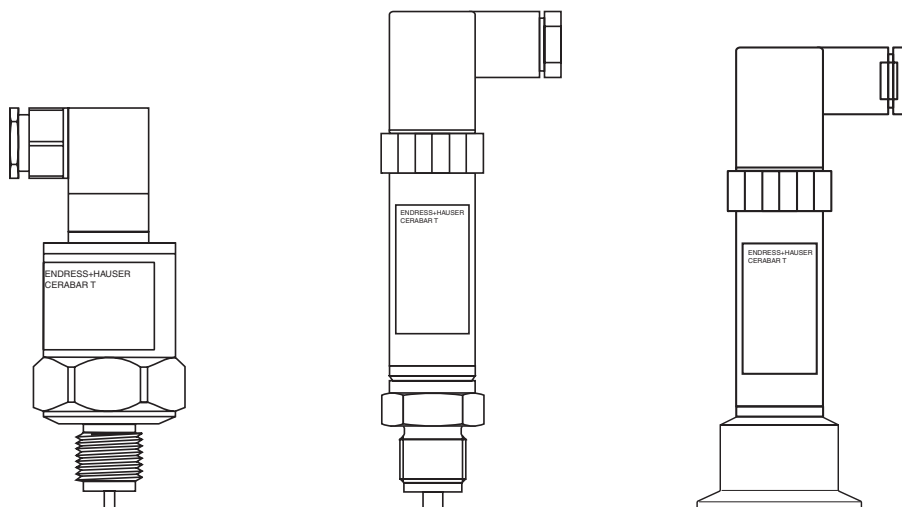

Application

Pressure measurements (e.g. limit pressure monitoring) to satisfy particular safety systems requirements as per IEC 61508/ IEC 61511-1.

The measuring device fulfils the requirements concerning

- Functional safety as per IEC 61508/IEC 61511-1
- Explosion protection (depending on the version)
- Electromagnetic compatibility as per EN 61326 and NAMUR recommendation NE 21.

Your benefits

- Used for limit pressure monitoring up to SIL 2, independently evaluated (Functional Assessment) by TÜV Rheinland as per IEC 61508/ IEC 61511-1
- Continuous measurement
- Easy commissioning

Table of contents

SIL declaration of conformity	3
General	4
Safety function with Cerabar T	4
Sicherheitsfunktion zur Grenzdrucküberwachung	4
Safety function data	4
Supplementary device documentation PMP131/PMP135	5
Supplementary device documentation PMC131	5
Iterative tests	5
Using the Cerabar T for continuous measurements	5
Settings	5
Settings	5
Safety-related parameters	6
Specific safety-related parameters for Cerabar T	6
PFDav dependent on selected maintenance interval	6
Repair	6
TÜV Management Summary	7

SIL declaration of conformity

SIL-Konformitätserklärung Funktionale Sicherheit nach IEC 61508 / IEC 61511 SIL Declaration of Conformity Functional safety according to IEC 61508 / IEC 61511

SIL-03004c/00/a2

Endress+Hauser GmbH+Co. KG, Hauptstraße 1, 79689 Maulburg



erklärt als Hersteller, dass die Drucktransducer
declares as manufacturer, that the pressure transducer

Cerabar T PMP131, PMP135, PMC131 (4...20 mA)

für den Einsatz in Schutzeinrichtungen entsprechend der 61511-1 geeignet ist, wenn die
Sicherheitshinweise und nachfolgende Parameter beachtet werden:
is suitable for the use in safety-instrumented systems according to IEC 61511-1, if the safety
instructions and following parameters are observed:

Gerät/ Product	Cerabar T PMP131 / PMP135	Cerabar T PMC131 ⁴⁾
SIL	2	
Prüfintervall/Proof test interval	≤ 1 Jahr/year	
Gerätetyp/Device type	A	B
HFT ¹⁾	0 (einkanale Verwendung/single channel use)	
SFF	81,5 %	89,7 %
PFD _{av} ²⁾	2,58 x 10 ⁻⁵	1,10 x 10 ⁻⁴
λ _{du}	5,9 FIT	25,2 FIT
λ _{dd} + λ _{safe}	25,9 FIT	220,7 FIT
MTBF _{tot} ³⁾	> 150 Jahre/years	
¹⁾ gemäß Absatz/according to clause 11.4.4 of IEC 61511-1 ²⁾ die Werte entsprechen SIL 2 nach ISA S84.01/ the values comply with SIL2 according to ISA S84.01. ³⁾ gemäß Siemens SN29500, einschließlich Fehlern, die außerhalb der Sicherheitsfunktion liegen according to Siemens SN29500, including faults outside the safety function ⁴⁾ Gültigkeit der SIL-Bewertung: Auslieferdatum September 1997 bis März 2006 validity of the SIL-evaluation: for devices delivered from september 1997 to march 2006		

Das Gerät einschließlich Änderungsprozess wurde auf Basis der Betriebsbewährung bewertet.
The device including the modification process was assessed on the basis of prior use.

Maulburg, 10.10.2006

Endress+Hauser GmbH+Co. KG

i.V.
Leitung Zertifizierungsstelle
Management Certification Department

i.A.
Leitung Entwicklungsprojekt
Management R&D Project

Endress+Hauser
People for Process Automation

General



Note!

For general information about SIL please refer to: www.de.endress.com/sil and in the Competence Brochure CP002Z: "Safety in the Process Industry – reducing risks with SIL"

Safety function with Cerabar T

Sicherheitsfunktion zur Grenzdrucküberwachung

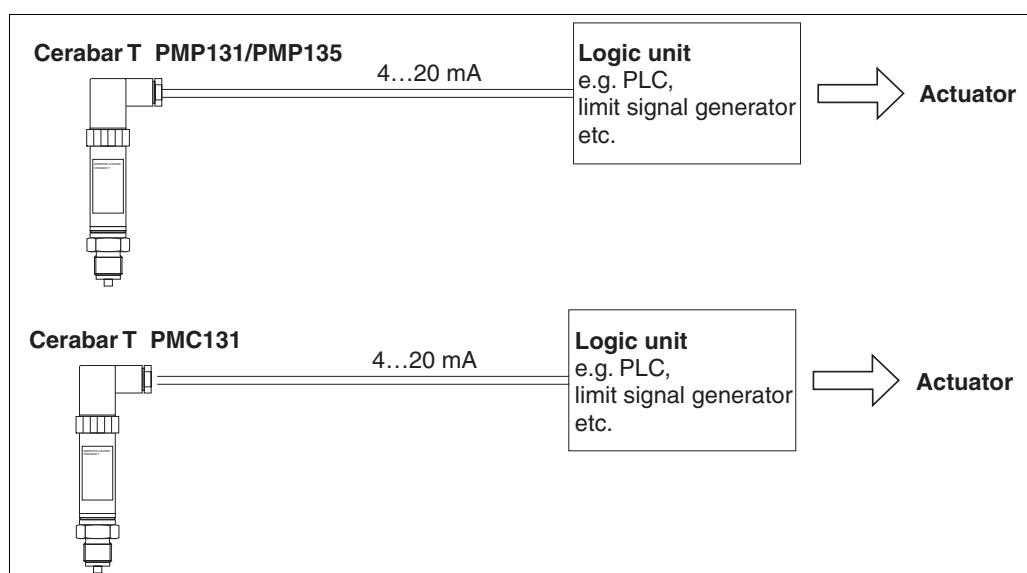

Fig. 2: Safety function (e.g. for limit pressure monitoring) with Cerabar T as sub-system

The Cerabar T transmitter generates an analogue signal (4...20 mA) proportional to the pressure. The analogue signal is fed to a downstream logic unit, such as a PLC or limit signal generator, and there it is monitored to determine whether it exceeds a maximum value. In order to monitor for faults, the logic unit must be able to detect both HI-alarms > 20 mA and LO-alarms < 3.6 mA.

Safety function data

Caution!

The data for the safety functions are listed in the "Safety-related parameters" chapter.

For the rise time of the transmitter see Technical Information TI415P.

Note!

MTTR is set at eight hours.

Safety-related systems without a self-locking function must be monitored or set to an otherwise safe state after carrying out the safety function within MTTR.

Cerabar T PMC131

The SIL assessment of PMC131 is valid from delivery date September 1997 to March 2006.

Cerabar T PMP135

The TÜV certificate is also valid for PMP135 because it is identical in construction to PMP131. They differ only in the process connections.

Supplementary device documentation PMP131/PMP135

Depending on the version, the following documentation must be available for the pressure transducer PMP131/PMP135:

Explosion protection/ Certificates	Operating Instructions	Other Ex-Documentation
none	KA103P	none
ATEX II 1/2 G EEx ib IIC T6	KA103P	Safety Instructions XA142P
ATEX II 2 G EEx ib IIC T6	KA103P	Safety Instructions XA142P
ATEX II 3 G EEx nA II T6	KA103P	Safety Instructions XA191P

Caution!

- The installation and setting instructions, and the technical limit values must be observed in accordance with the Operating Instructions (KA103P).
- For devices which are used in explosion-hazardous, the supplementary documentation (XA) must also be used in accordance with the table.

Cerabar T PMP131/PMP135 supplementary documentation

For further information, see Technical Information TI415P.

Supplementary device documentation PMC131

Depending on the version, the following documentation must be available for the pressure transducer PMC131:

Explosion protection/ Certificates	Operating Instructions	Other Ex-Documentation
none	KA 085P	none
ATEX II 3 G EEx nA II T4	KA 085P	Safety Instructions XA 191P

Caution!

- The installation and setting instructions, and the technical limit values must be observed in accordance with the Operating Instructions (KA085P).
- For devices which are used in explosion-hazardous, the supplementary documentation (XA) must also be used in accordance with the table.

Cerabar T PMC131 supplementary documentation

For further information, see Technical Information TI415P.

Iterative tests

Using the Cerabar T for continuous measurements

The operability of the measuring device must be tested at appropriate time intervals. We recommend carrying out the test at least once a year. It is the responsibility of the user to select the type of check and the intervals in the specified time frame.

Settings

Settings

The zero point can be set for the Cerabar T. If you use the Cerabar T as a sub-system of a safety function, the zero point must not be adjusted during operation.

Safety-related parameters

Specific safety-related parameters for Cerabar T

The table displays the specific safety-related parameters for the Cerabar T.

	PMP131/PMP135 (Type A)	PMC131 (Type B)
SIL	SIL 2 as per IEC 61508	SIL 2 as per IEC 61511
HFT	0	0
SFF	81.5 %	89.7 %
PFD_{av}	2.58×10^{-5}	1.10×10^{-4}
TI ¹⁾	annual	annual

1) Complete function test

PFD_{av} dependent on selected maintenance interval

The following diagram presents the dependence of the PFD_{av} on the maintenance interval. The PFD_{av} increases as the maintenance interval increases.

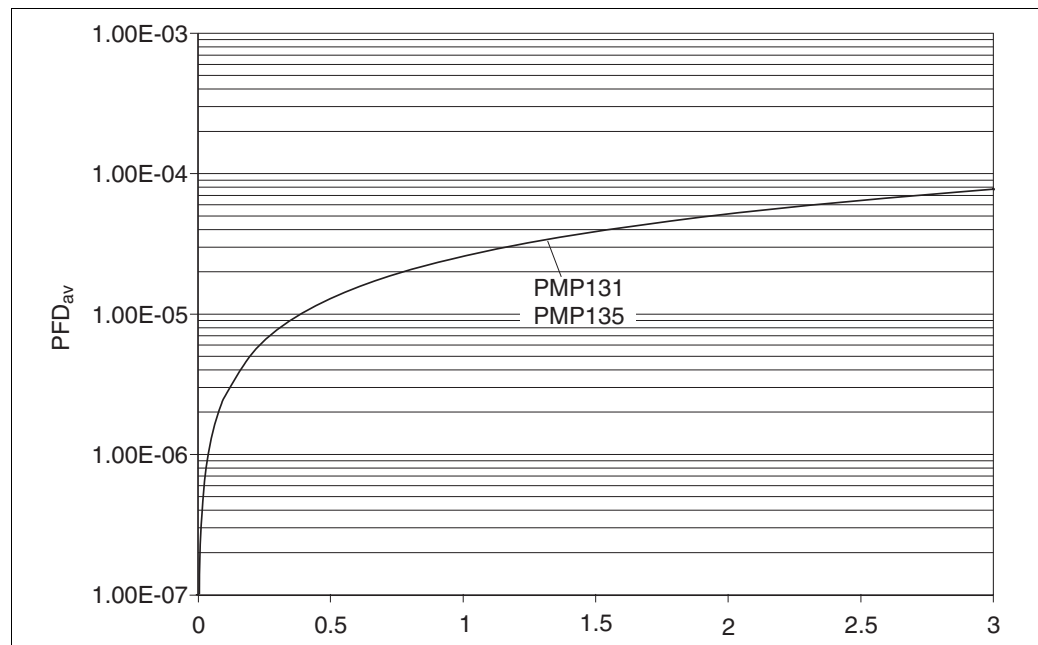



Fig. 4: "Average Probability of Failure on Demand" (PFD_{av}) dependent on the selected maintenance interval

Repair

When device components are replaced, the SIL declaration of conformity becomes invalid. If a SIL-marked device that has been operated in a functional safety application fails, the "Declaration of Hazardous Material and De-Contamination" form containing the appropriate information "Used as a SIL device in a Safety Instrumented System" must be enclosed with the defective device when it is returned.

TÜV Management Summary



TÜV Rheinland
Berlin Brandenburg

2003-01-27

5. Summary

Based on the submitted manufacturer documents an assessment of safety relevant parameters (failure rates, PFD_{av}, HFT and SFF) has been carried out for different pressure sensors, manufactured by the Endress+Hauser company. The assessment, that covers the pressure instruments type Cerabar S, Deltabar S, and Cerabar T, was carried out in compliance with the requirements of IEC 61508 and IEC 61511 (FDIS).

The assessment showed the following results:

Type A component: Cerabar T PMP131

The safety relevant parameters PFD_{av}, HFT and SFF are in compliance with the corresponding requirements for **SIL 2** according to IEC 61508.

Type B components: Cerabar S, Deltabar S, Cerabar T PMC131

The safety relevant parameter PFD_{av} is in compliance with the corresponding requirements for **SIL 2** according to IEC 61508.

The safety relevant parameters HFT and SFF are in compliance with the corresponding requirements for **SIL 1** according to IEC 61508.

The safety relevant parameters HFT and SFF are in compliance with the corresponding requirements for **SIL 2** according to IEC 61511(FDIS).

The user should consider, that the hardware fault tolerance of all inspected devices is zero and that a single fault can lead to a dangerous failure.

NOTES:

The assessment results described in this report only refer to the safety-related parameters PFD_{av}, HFT and SFF according to IEC 61508 and IEC 61511 (FDIS).

This report does not make any statements, that the manufacturer meets all other requirements of the above cited standards for hardware, software, documentation, management of functional safety, verification and validation.

This report does not imply that the examined pressure sensors have been certified for functional safety by the assessor according to IEC 61508 or any other standards.

The pressure sensors are only one part of a complete safety function. It is at the responsibility of the end-user to prepare and to apply an extensive reliability model, that brings out the complete safety function and that meets all requirements of the claimed SIL level according to IEC 61508.

Cologne, 2003-01-27
AS/Kst. 968 ja-nle

The inspector

Dipl.-Phys. Erich Janoschek

Report-No.: 968/EL 193.00/03

Page 12 of 12

P01-xxxxxxx-02-xx-xx-en-001



TÜV Rheinland
Berlin Brandenburg

2003-01-27

Automation, Software and Information Technology

Test report about the determination of safety-related parameters according to IEC 61508 and IEC 61511 (FDIS) for the Endress+Hauser smart pressure transmitters Cerabar S, smart differential pressure transmitters Deltabar S and pressure transducers Cerabar T

Report-No.: 968/EL 193.00/03
Date: 2003-01-27

Report-No.: 968/EL 193.00/03

Page 1 of 12

P01-xxxxxxx-02-xx-xx-en-000

International Head Quarter

Endress+Hauser
GmbH+Co. KG
Instruments International
Colmarer Str. 6
79576 Weil am Rhein
Deutschland

Tel. +49 76 21 9 75 02
Fax +49 76 21 9 75 34 5
www.endress.com
info@ii.endress.com

Endress+Hauser 
People for Process Automation

