

Brief Operating Instructions Proline Promag L

Electromagnetic sensor

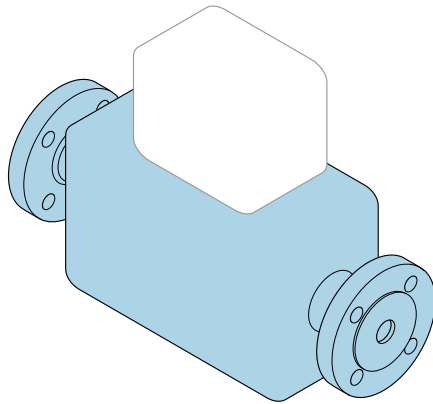

These Brief Operating Instructions are **not** a substitute for the Operating Instructions pertaining to the device.

Brief Operating Instructions Part 1 of 2: Sensor

Contain information about the sensor.

Brief Operating Instructions Part 2 of 2: Transmitter

→  3.



A0023555

Brief operating instructions Flowmeter

The device consists of a transmitter and a sensor.

The process of commissioning these two components is described in two separate manuals which together form the Brief Operating Instructions for the flowmeter:

- Brief Operating Instructions Part 1: Sensor
- Brief Operating Instructions Part 2: Transmitter

Please refer to both parts of the Brief Operating Instructions when commissioning the device, as the contents of the manuals complement one another:

Brief Operating Instructions Part 1: Sensor

The Sensor Brief Operating Instructions are aimed at specialists with responsibility for installing the measuring device.

- Incoming acceptance and product identification
- Storage and transport
- Mounting procedure

Brief Operating Instructions Part 2: Transmitter

The Transmitter Brief Operating Instructions are aimed at specialists with responsibility for commissioning, configuring and parameterizing the measuring device (until the first measured value).

- Product description
- Mounting procedure
- Electrical connection
- Operation options
- System integration
- Commissioning
- Diagnostic information

Additional device documentation



These Brief Operating Instructions are the **Brief Operating Instructions part 1: Sensor**.

The "Brief Operating Instructions part 2: Transmitter" are available via:

- Internet: www.endress.com/deviceviewer
- Smart phone/tablet: *Endress+Hauser Operations App*

Detailed information about the device can be found in the Operating Instructions and the other documentation:

- Internet: www.endress.com/deviceviewer
- Smart phone/tablet: *Endress+Hauser Operations App*

Table of contents

1	About this document	5
1.1	Symbols	5
2	Basic safety instructions	7
2.1	Requirements for the personnel	7
2.2	Intended use	7
2.3	Workplace safety	8
2.4	Operational safety	8
2.5	Product safety	8
2.6	IT security	8
3	Incoming acceptance and product identification	9
3.1	Incoming acceptance	9
3.2	Product identification	9
4	Storage and transport	10
4.1	Storage conditions	10
4.2	Transporting the product	10
5	Installation	12
5.1	Installation requirements	12
5.2	Mounting the measuring device	20
5.3	Post-installation check	25
6	Disposal	26
6.1	Removing the measuring device	26
6.2	Disposing of the measuring device	26
7	Appendix	27
7.1	Screw tightening torques	27

1 About this document

1.1 Symbols

1.1.1 Safety symbols

⚠ DANGER

This symbol alerts you to a dangerous situation. Failure to avoid this situation will result in serious or fatal injury.

⚠ WARNING

This symbol alerts you to a potentially dangerous situation. Failure to avoid this situation can result in serious or fatal injury.









⚠ CAUTION

This symbol alerts you to a potentially dangerous situation. Failure to avoid this situation can result in minor or medium injury.





NOTICE

This symbol alerts you to a potentially harmful situation. Failure to avoid this situation can result in damage to the product or something in its vicinity.

1.1.2 Symbols for certain types of information





Symbol	Meaning	Symbol	Meaning
	Permitted Procedures, processes or actions that are permitted.		Preferred Procedures, processes or actions that are preferred.
	Forbidden Procedures, processes or actions that are forbidden.		Tip Indicates additional information.
	Reference to documentation		Reference to page
	Reference to graphic	1, 2, 3...	Series of steps
	Result of a step		Visual inspection

1.1.3 Electrical symbols





Symbol	Meaning	Symbol	Meaning
	Direct current		Alternating current
	Direct current and alternating current		Ground connection A grounded terminal which, as far as the operator is concerned, is grounded via a grounding system.

Symbol	Meaning
	<p>Potential equalization connection (PE: Protective earth) Ground terminals that must be connected to ground prior to establishing any other connections.</p> <p>The ground terminals are located on the interior and exterior of the device:</p> <ul style="list-style-type: none"> ■ Interior ground terminal: potential equalization connection is connected to the supply network. ■ Exterior ground terminal: device is connected to the plant grounding system.





1.1.4 Communication-specific symbols

Symbol	Meaning	Symbol	Meaning
	<p>LED LED is on.</p>		<p>LED LED is off.</p>
	<p>LED LED flashing.</p>		<p>Wireless Local Area Network (WLAN) Communication via a wireless, local area network</p>
	<p>Promag 10, 400, 800 Bluetooth Wireless data transmission between devices over a short distance via radio technology</p>		

1.1.5 Tool symbols

Symbol	Meaning	Symbol	Meaning
	Torx screwdriver		Flat-blade screwdriver
	Phillips screwdriver		Allen key
	Open-end wrench		

1.1.6 Symbols in graphics

Symbol	Meaning	Symbol	Meaning
1, 2, 3,...	Item numbers		Series of steps
A, B, C, ...	Views	A-A, B-B, C-C, ...	Sections
	Hazardous area		Safe area (non-hazardous area)
	Flow direction		

2 Basic safety instructions

2.1 Requirements for the personnel

The personnel must fulfill the following requirements for its tasks:

- ▶ Trained, qualified specialists must have a relevant qualification for this specific function and task.
- ▶ Are authorized by the plant owner/operator.
- ▶ Are familiar with federal/national regulations.
- ▶ Before starting work, read and understand the instructions in the manual and supplementary documentation as well as the certificates (depending on the application).
- ▶ Follow instructions and comply with basic conditions.

2.2 Intended use

Application and media

The measuring instrument is intended only for the flow measurement of liquids with a minimum conductivity of 5 $\mu\text{S}/\text{cm}$.

Depending on the version ordered, the measuring instrument can also be used to measure potentially explosive ¹⁾, flammable, toxic and oxidizing media.

Measuring instruments for use in hazardous areas, in hygienic applications, or where there is an increased risk due to pressure, are specially labeled on the nameplate.

To ensure that the measuring instrument is in perfect condition during operation:

- ▶ Only use the measuring instrument in full compliance with the data on the nameplate and the general conditions listed in the Operating Instructions and supplementary documentation.
- ▶ Using the nameplate, check whether the ordered device is permitted for the intended use in the hazardous area (e.g. explosion protection, pressure vessel safety).
- ▶ Use the measuring instrument only for media to which the process-wetted materials are sufficiently resistant.
- ▶ Keep within the specified pressure and temperature range.
- ▶ Keep within the specified ambient temperature range.
- ▶ Protect the measuring instrument permanently against corrosion from environmental influences.

Incorrect use

Non-designated use can compromise safety. The manufacturer is not liable for damage caused by improper or non-designated use.

WARNING

Danger of breakage due to corrosive or abrasive fluids and ambient conditions!

- ▶ Verify the compatibility of the process fluid with the sensor material.
- ▶ Ensure the resistance of all fluid-wetted materials in the process.
- ▶ Keep within the specified pressure and temperature range.

1) Not applicable for IO-Link measuring instruments

NOTICE**Verification for borderline cases:**

- ▶ For special fluids and fluids for cleaning, Endress+Hauser is glad to provide assistance in verifying the corrosion resistance of fluid-wetted materials, but does not accept any warranty or liability as minute changes in the temperature, concentration or level of contamination in the process can alter the corrosion resistance properties.

Residual risks**⚠ CAUTION****Risk of hot or cold burns! The use of media and electronics with high or low temperatures can produce hot or cold surfaces on the device.**

- ▶ Mount suitable touch protection.

2.3 Workplace safety

When working on and with the device:

- ▶ Wear the required personal protective equipment as per national regulations.

2.4 Operational safety

Risk of injury!

- ▶ Operate the device in proper technical condition and fail-safe condition only.
- ▶ The operator is responsible for interference-free operation of the device.

Ambient requirements for transmitter housing made of plastic

If a plastic transmitter housing is permanently exposed to certain steam and air mixtures, this can damage the housing.

- ▶ If you are unsure, please contact your Endress+Hauser Sales Center for clarification.
- ▶ If used in an approval-related area, observe the information on the nameplate.

2.5 Product safety

This measuring device is designed in accordance with good engineering practice to meet state-of-the-art safety requirements, has been tested, and left the factory in a condition in which it is safe to operate.

It meets general safety standards and legal requirements. It also complies with the EU directives listed in the device-specific EU Declaration of Conformity. The manufacturer confirms this by affixing the CE mark to the device..

2.6 IT security

The manufacturer warranty is valid only if the product is installed and used as described in the Operating Instructions. The product is equipped with security mechanisms to protect it against any inadvertent changes to the settings.

IT security measures, which provide additional protection for the product and associated data transfer, must be implemented by the operators themselves in line with their security standards.

3 Incoming acceptance and product identification

3.1 Incoming acceptance

On receipt of the delivery:

1. Check the packaging for damage.
 - ↳ Report all damage immediately to the manufacturer.
Do not install damaged components.
2. Check the scope of delivery using the delivery note.
3. Compare the data on the nameplate with the order specifications on the delivery note.
4. Check the technical documentation and all other necessary documents, e.g. certificates, to ensure they are complete.



If one of the conditions is not satisfied, contact the manufacturer.

3.2 Product identification

The device can be identified in the following ways:

- Nameplate
- Order code with details of the device features on the delivery note
- Enter the serial numbers from the nameplates in the *Device Viewer* (www.endress.com/deviceviewer): all the information about the device is displayed.
- Enter the serial numbers from the nameplates into the *Endress+Hauser Operations app* or scan the DataMatrix code on the nameplate with the *Endress+Hauser Operations app*: all the information about the device is displayed.

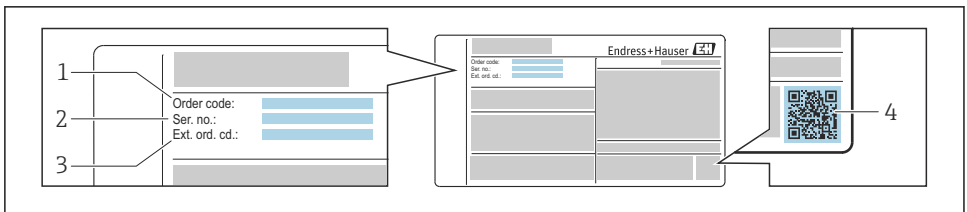

A0030196

1 Example of a nameplate

- 1 Order code
- 2 Serial number
- 3 Extended order code
- 4 2-D matrix code (QR code)



For detailed information on the data on the nameplate, see the Operating Instructions for the device.

4 Storage and transport

4.1 Storage conditions

Observe the following notes for storage:

- ▶ Store in the original packaging to ensure protection from shock.
- ▶ Do not remove protective covers or protective caps installed on process connections. They prevent mechanical damage to the sealing surfaces and contamination in the measuring tube.
- ▶ Protect from direct sunlight. Avoid unacceptably high surface temperatures.
- ▶ Select a storage location that excludes the possibility of condensation forming on the measuring device. Fungi and bacteria can damage the liner.
- ▶ Store in a dry and dust-free place.
- ▶ Do not store outdoors.

4.2 Transporting the product

Transport the measuring device to the measuring point in the original packaging.

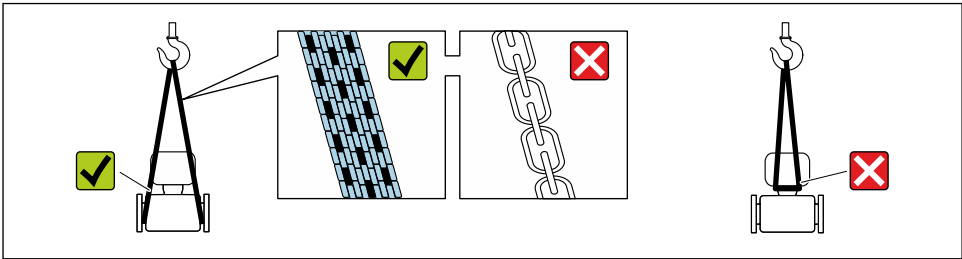

A0029252

i Do not remove protective covers or caps installed on process connections. They prevent mechanical damage to the sealing surfaces and contamination in the measuring tube.

4.2.1 Measuring devices without lifting lugs

⚠ WARNING

Center of gravity of the measuring device is higher than the suspension points of the webbing slings.

Risk of injury if the measuring device slips.

- ▶ Secure the measuring device against slipping or turning.
- ▶ Observe the weight specified on the packaging (stick-on label).

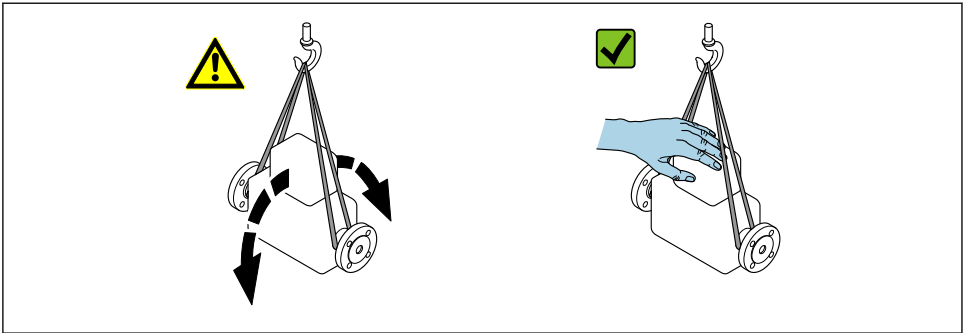

A0029214

4.2.2 Measuring devices with lifting lugs

CAUTION

Special transportation instructions for devices with lifting lugs

- ▶ Only use the lifting lugs fitted on the device or flanges to transport the device.
- ▶ The device must always be secured at two lifting lugs at least.

4.2.3 Transporting with a fork lift

If transporting in wood crates, the floor structure enables the crates to be lifted lengthwise or at both sides using a forklift.

CAUTION

Risk of damaging the magnetic coil!

- ▶ If transporting by forklift, do not lift the sensor by the metal casing.
- ▶ This would buckle the casing and damage the internal magnetic coils.

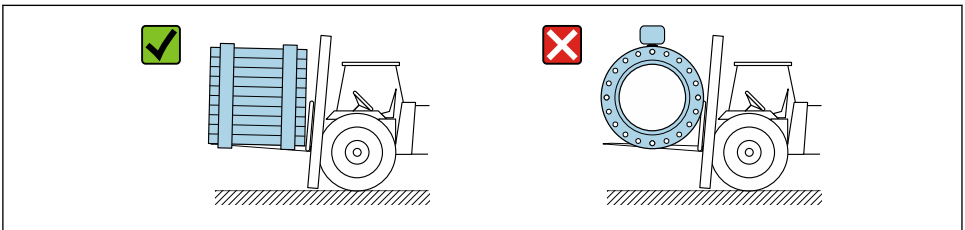

A0029319

5 Installation

5.1 Installation requirements

5.1.1 Mounting position

Mounting location

- Do not install the device at the highest point of the pipe.
- Do not install the device upstream from a free pipe outlet in a down pipe.

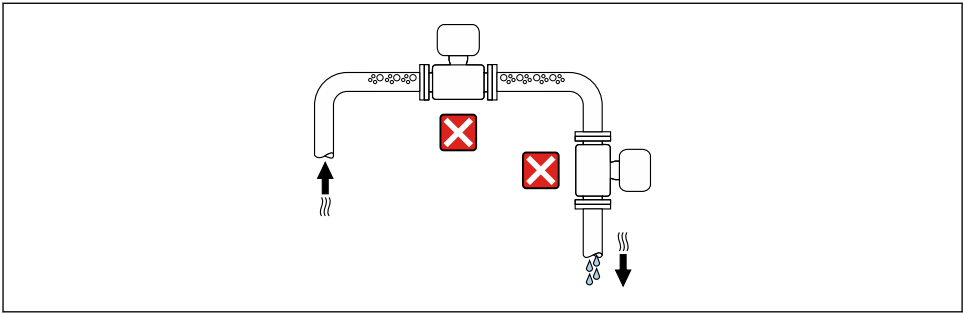

A0042131

The device should ideally be installed in an ascending pipe.

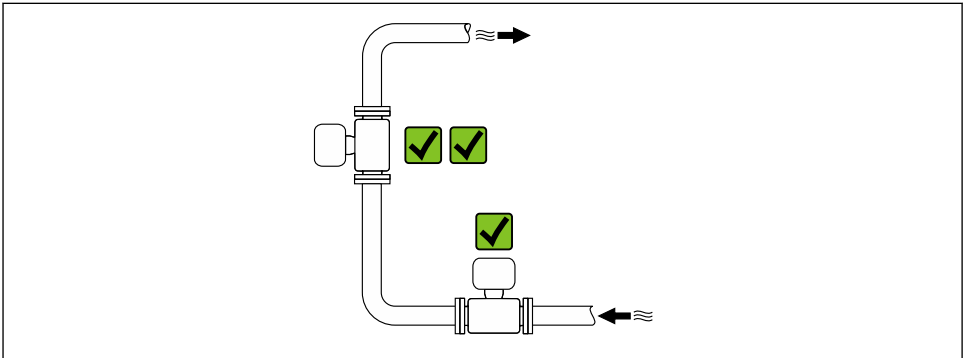

A0042317

*Installation upstream from a down pipe***NOTICE****Negative pressure in the measuring pipe can damage the liner!**

- ▶ If installing upstream of down pipes whose length $h \geq 5 \text{ m}$ (16.4 ft): install a siphon with a vent valve downstream of the device.



This arrangement prevents the flow of liquid stopping in the pipe and air entrainment.

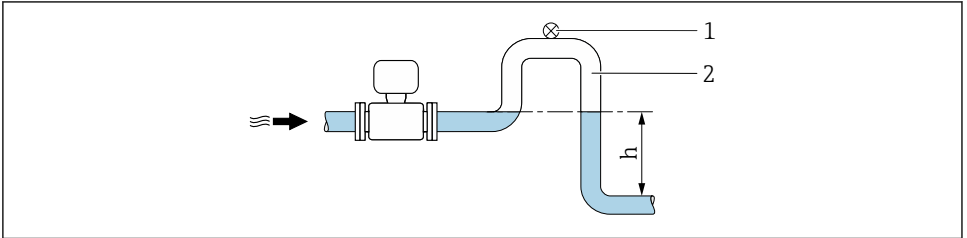

A0028981

- 1 Vent valve
- 2 Pipe siphon
- h Length of down pipe

Installation with partially filled pipes

- Partially filled pipes with a gradient require a drain-type configuration.
- The installation of a cleaning valve is recommended.

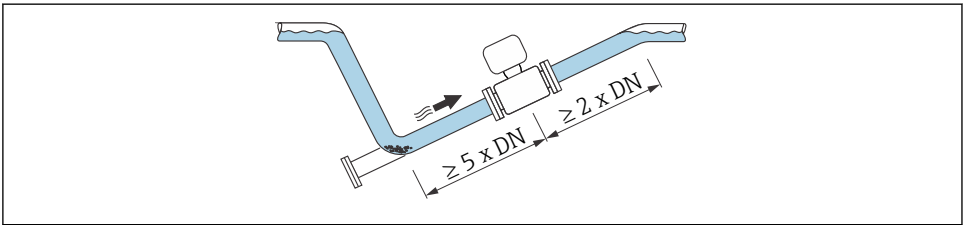

A0041088

*Installation near pumps***NOTICE****Negative pressure in the measuring tube can damage the liner!**

- ▶ In order to maintain the system pressure, install the device in the flow direction downstream from the pump.
- ▶ Install pulsation dampers if reciprocating, diaphragm or peristaltic pumps are used.

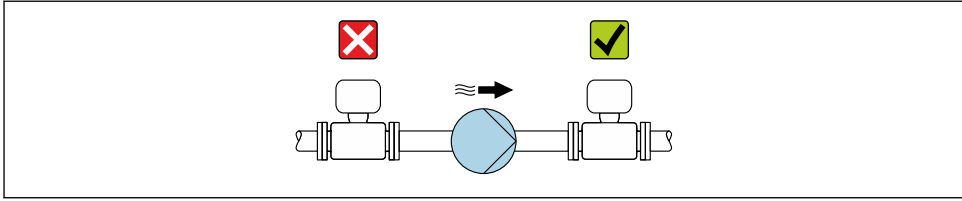

A0041083

Installation of very heavy devices

Support required for nominal diameters of $DN \geq 350$ mm (14 in).

NOTICE

Damage to the device!

If incorrect support is provided, the sensor housing could buckle and the internal magnetic coils could be damaged.

- ▶ Only provide supports at the pipe flanges.

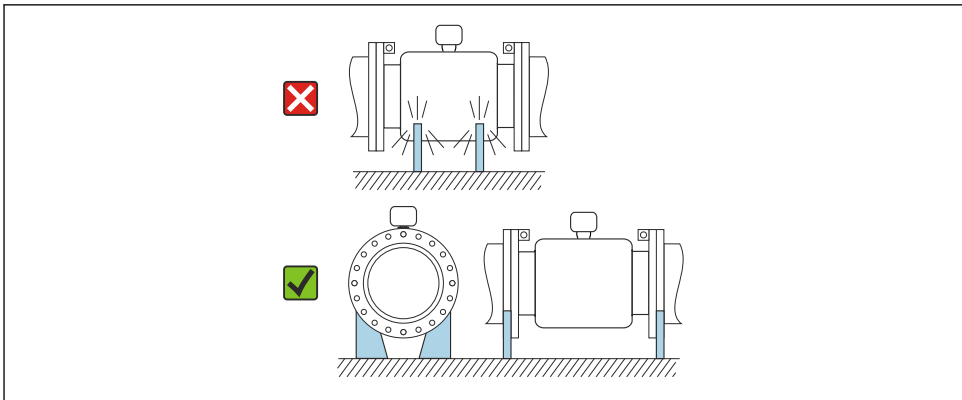

A0041087

Installation in event of pipe vibrations

A remote version is recommended in the event of strong pipe vibrations.

NOTICE

Pipe vibrations can damage the device!



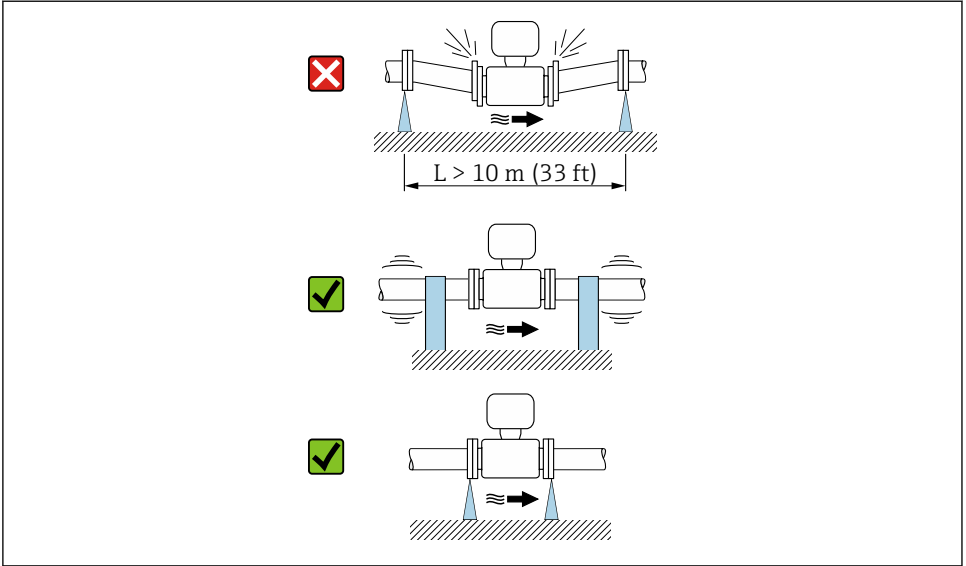



- ▶ Do not expose the device to strong vibrations.
- ▶ Support the pipe and fix it in place.
- ▶ Support the device and fix it in place.
- ▶ Mount the sensor and transmitter separately.

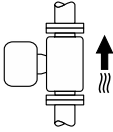
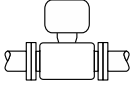
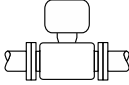

A0041092

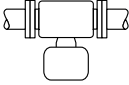
Orientation

The direction of the arrow on the nameplate helps you to install the measuring device according to the flow direction.

Orientation		Recommendation
Vertical orientation	 <p style="text-align: right;">A0015591</p>	
Horizontal orientation, transmitter at top	 <p style="text-align: right;">A0015589</p>	 ¹⁾
Horizontal orientation, transmitter at bottom	 <p style="text-align: right;">A0015590</p>	 ^{2) 3)}  ⁴⁾
Horizontal orientation, transmitter at side	 <p style="text-align: right;">A0015592</p>	

- 1) Applications with low process temperatures may reduce the ambient temperature. To maintain the minimum ambient temperature for the transmitter, this orientation is recommended.
- 2) Applications with high process temperatures may increase the ambient temperature. To maintain the maximum ambient temperature for the transmitter, this orientation is recommended.
- 3) To prevent the electronics from overheating in the event of strong heat formation (e.g. CIP or SIP cleaning process), install the device with the transmitter part pointing downwards.
- 4) With the empty pipe detection function switched on: empty pipe detection only works if the transmitter housing is pointing upwards.

Vertical

Optimum for self-emptying pipe systems and for use in conjunction with empty pipe detection.

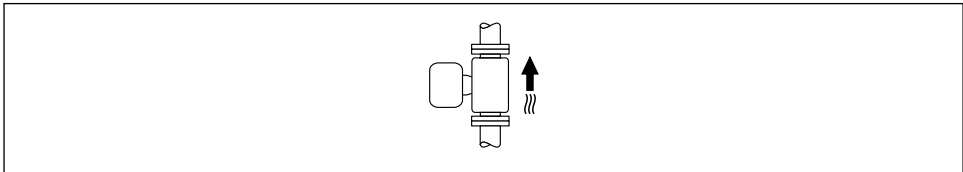

Horizontal

- Ideally, the measuring electrode plane should be horizontal. This prevents brief insulation of the measuring electrodes by entrained air bubbles.
- Empty pipe detection only works if the transmitter housing is pointing upwards as otherwise there is no guarantee that the empty pipe detection function will actually respond to a partially filled or empty measuring tube.

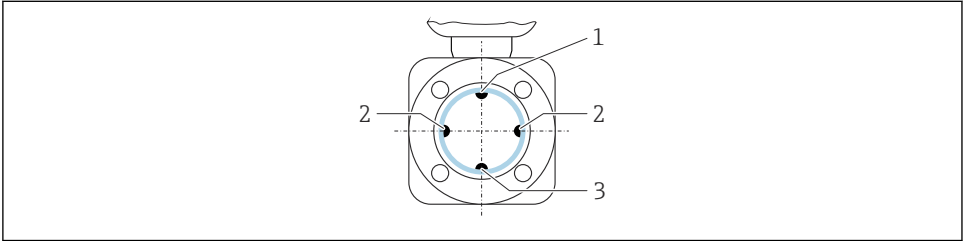

A0029344

- 1 *EPD electrode for empty pipe detection*
- 2 *Measuring electrodes for signal detection*
- 3 *Reference electrode for potential equalization*

Inlet and outlet runs

5.1.2 Environmental and process requirements

Ambient temperature range

 For detailed information on the ambient temperature range, see the Operating Instructions for the device.

If operating outdoors:

- Mount the measuring instrument in a shady location.
- Avoid direct sunlight, particularly in warm climatic regions.
- Avoid direct exposure to weather conditions.

Temperature tables²⁾

 For detailed information on the temperature tables, see the separate document entitled "Safety Instructions" (XA) for the device.

System pressure

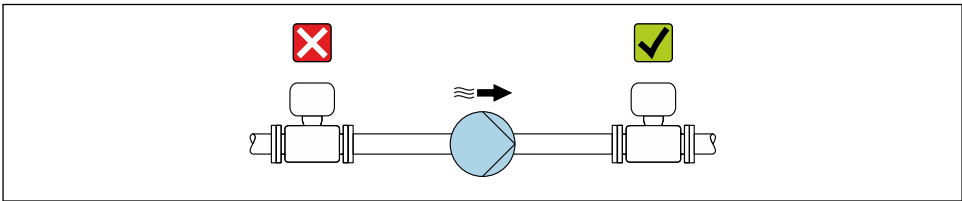

A0028777

 Furthermore, install pulse dampers if reciprocating, diaphragm or peristaltic pumps are used.

Vibrations

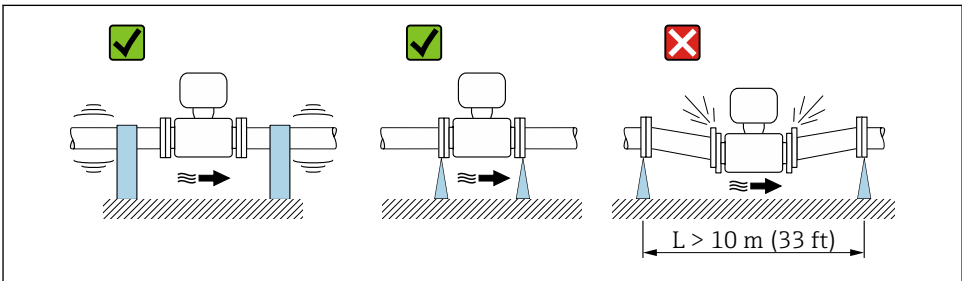

A0029004

 2 Measures to prevent vibration of the device

2) Not applicable for IO-Link measuring instruments

Adapters

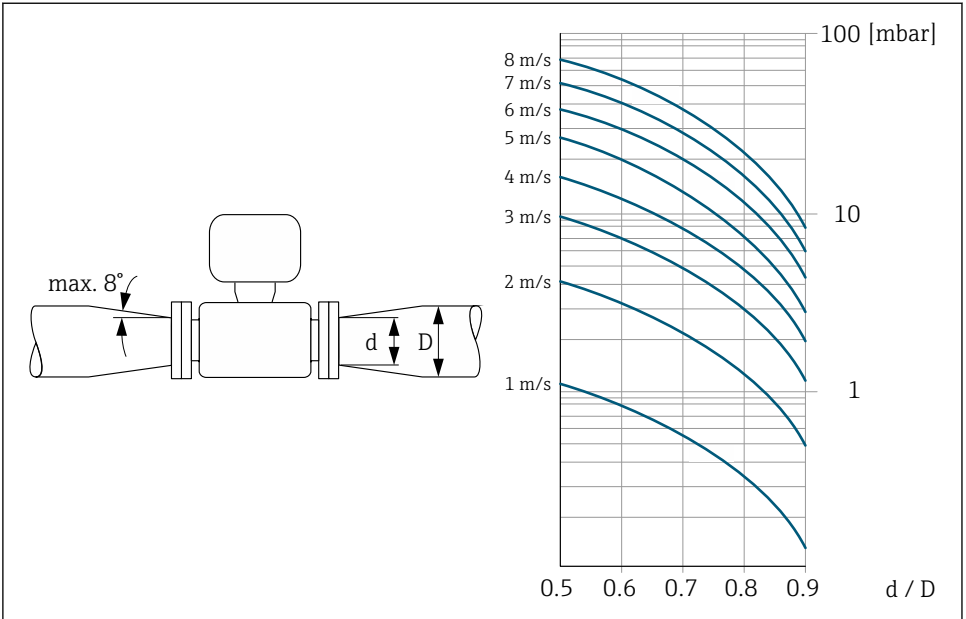

A0029002

5.1.3 Special installation instructions

Weather protection cover: Proline 300

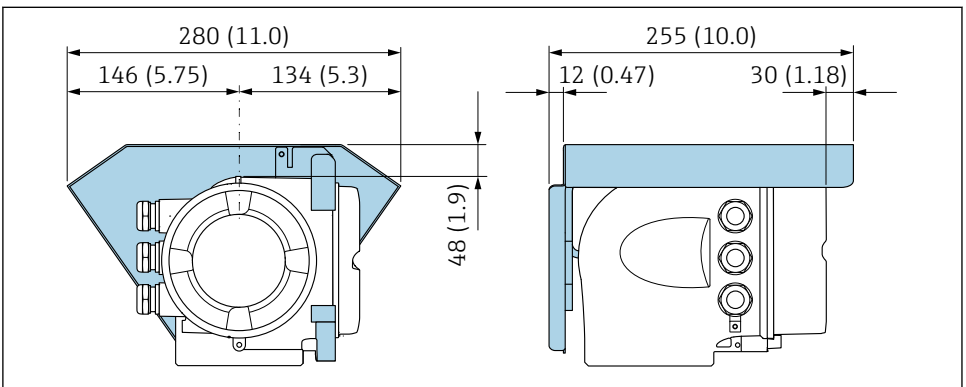

A0029553

3 Unit mm (in)

Temporary immersion in water

A remote version with IP67 protection, Type 6 is optionally available for temporary immersion in water for up to 168 hours at ≤ 3 m (10 ft) or in exceptional cases for use for up to 48 hours at ≤ 10 m (30 ft).

Compared with the standard degree of protection IP67, Type 4X enclosure, the version IP67, Type 6 enclosure has been designed to withstand short-term or temporary flooding.

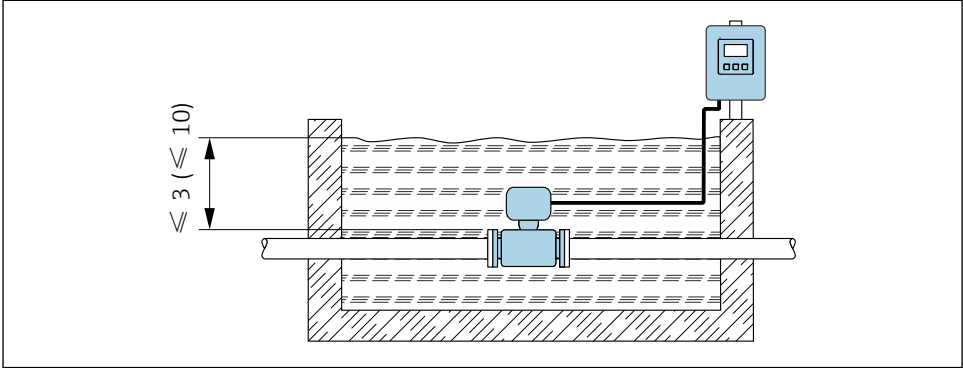

A0029320

 4 Engineering unit in m(ft)

 For detailed information on replacing the cable gland on the connection housing, see the Transmitter Brief Operating Instructions.

5.2 Mounting the measuring device

5.2.1 Required tools

For flanges and other process connections, use an appropriate mounting tool

5.2.2 Preparing the measuring device

1. Remove all remaining transport packaging.
2. Remove any protective covers or protective caps present from the sensor.
3. Remove stick-on label on the electronics compartment cover.

5.2.3 Mounting the sensor

⚠ WARNING

An electrically conductive layer could form on the inside of the measuring tube!

Risk of measuring signal short circuit.

- ▶ Ensure that the inside diameters of the gaskets are greater than or equal to that of the process connections and piping.
- ▶ Ensure that the gaskets are clean and undamaged.
- ▶ Install the gaskets correctly.
- ▶ Do not use electrically conductive sealing compounds such as graphite.

⚠ WARNING

Danger due to improper process sealing!

- ▶ Ensure that the inside diameters of the gaskets are greater than or equal to that of the process connections and piping.
- ▶ Ensure that the gaskets are clean and undamaged.
- ▶ Install the gaskets correctly.

1. Ensure that the direction of the arrow on the sensor matches the flow direction of the medium.
2. To ensure compliance with device specifications, install the measuring device between the pipe flanges in a way that it is centered in the measurement section.
3. If using ground disks, comply with the Installation Instructions provided.
4. Observe required screw tightening torques .
5. Install the measuring device or turn the transmitter housing so that the cable entries do not point upwards.

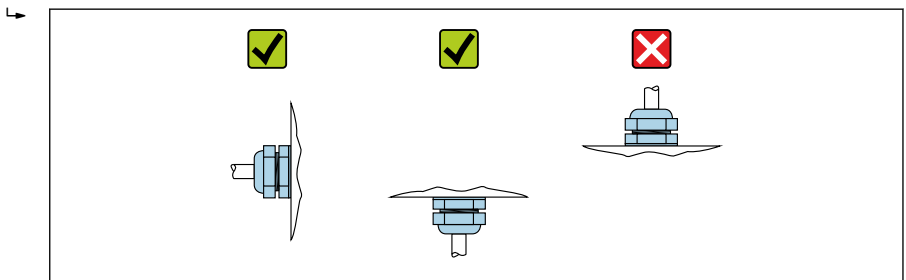

A0029263

Mounting the seals

⚠ CAUTION

An electrically conductive layer could form on the inside of the measuring tube!

Risk of measuring signal short circuit.

- ▶ Do not use electrically conductive sealing compounds such as graphite.

Comply with the following instructions when installing seals:

- Make sure that the seals do not protrude into the piping cross-section.
- For DIN flanges: only use seals according to DIN EN 1514-1.
- For "hard rubber" lining: additional seals are **always** required.
- For "polyurethane" lining: generally additional seals are **not** required.
- For "PTFE" lining: generally additional seals are **not** required.

Mounting the ground cable/ground disks

For information on potential equalization and detailed mounting instructions for the use of ground cables/ground disks, see the Transmitter Brief Operating Instructions.

Screw tightening torques

→  27

5.2.4 Mounting the transmitter of the remote version:

CAUTION

Ambient temperature too high!

Danger of electronics overheating and housing deformation.

- ▶ Do not exceed the permitted maximum ambient temperature .
- ▶ If operating outdoors: Avoid direct sunlight and exposure to weathering, particularly in warm climatic regions.

CAUTION

Excessive force can damage the housing!

- ▶ Avoid excessive mechanical stress.

Wall mounting

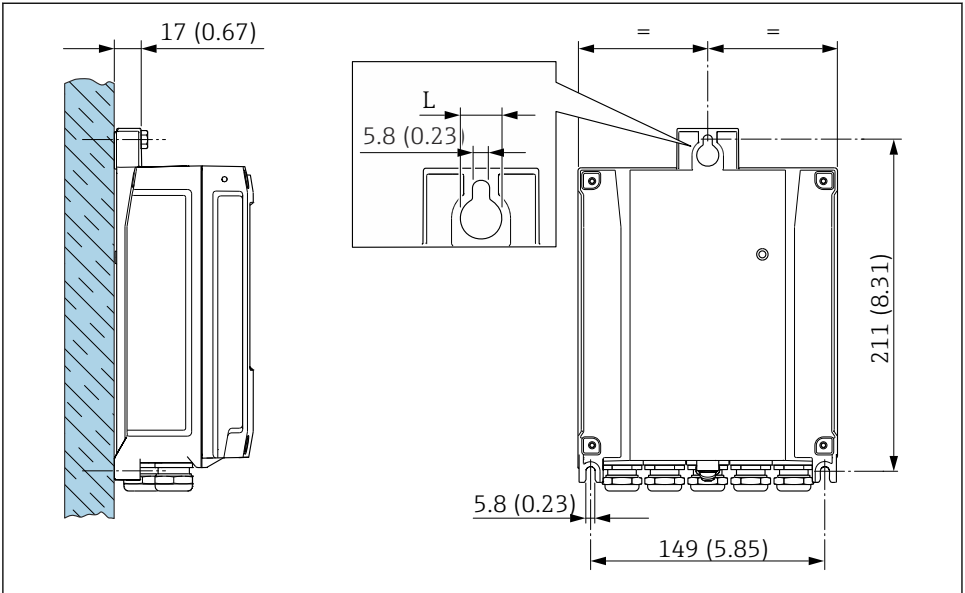

A0029054

5 Engineering unit mm (in)

L Depends on order code for "Transmitter housing"

Order code for "Transmitter housing"

- Option **A**, aluminum coated: $L = 14 \text{ mm (0.55 in)}$
- Option **D**, polycarbonate: $L = 13 \text{ mm (0.51 in)}$

Post mounting

⚠ WARNING

Excessive tightening torque applied to the fixing screws on plastic housing!

Risk of damaging the plastic transmitter.

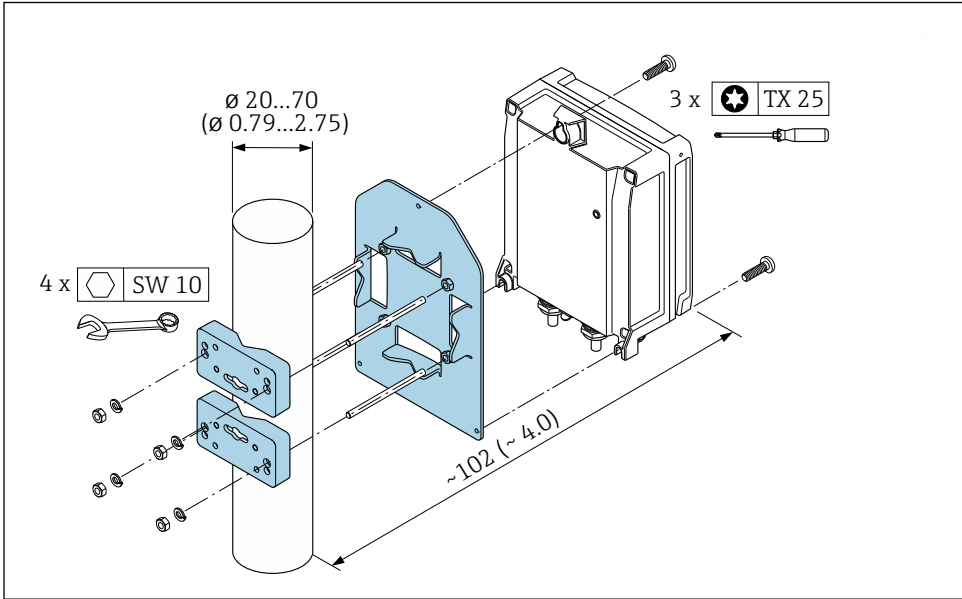

- ▶ Tighten the fixing screws as per the tightening torque: 2 Nm (1.5 lbf ft)



A0029051

 6 Engineering unit mm (in)

5.3 Post-installation check

Is the device undamaged (visual inspection)?	<input type="checkbox"/>
Does the measuring instrument correspond to the measuring point specifications? For example: <ul style="list-style-type: none"> ▪ Process temperature ▪ Process pressure (refer to the section on "Pressure-temperature ratings" in the "Technical Information" document. ▪ Ambient temperature ▪ Measuring range 	<input type="checkbox"/>
Has the correct orientation been selected for the sensor →  16 ? <ul style="list-style-type: none"> ▪ According to sensor type ▪ As per medium temperature ▪ As per medium properties (outgassing, with entrained solids) 	<input type="checkbox"/>
Does the arrow on the sensor match the direction of flow of the medium →  16?	<input type="checkbox"/>
Is the tag name and labeling correct (visual inspection)?	<input type="checkbox"/>
Is the device sufficiently protected from precipitation and direct sunlight?	<input type="checkbox"/>
Are the fixing screws tightened securely?	<input type="checkbox"/>

6 Disposal

 If required by the Directive 2012/19/EU on waste electrical and electronic equipment (WEEE), the product is marked with the depicted symbol in order to minimize the disposal of WEEE as unsorted municipal waste. Do not dispose of products bearing this marking as unsorted municipal waste. Instead, return them to the manufacturer for disposal under the applicable conditions.

6.1 Removing the measuring device

1. Switch off the device.

WARNING

Risk of personal injury due to process conditions!

- ▶ Beware of hazardous process conditions such as pressure in the measuring device, high temperatures or aggressive media.
2. Carry out the mounting and connection steps from the "Mounting the measuring device" and "Connecting the measuring device" sections in reverse order.
 3. Observe the safety instructions.

6.2 Disposing of the measuring device

WARNING

Danger to personnel and environment from fluids that are hazardous to health.

- ▶ Ensure that the measuring device and all cavities are free of fluid residues that are hazardous to health or the environment, e.g. substances that have permeated into crevices or diffused through plastic.

Follow these instructions when disposing of the device:

- ▶ Comply with national regulations.
- ▶ Ensure proper separation and reuse of the device components.

7 Appendix

7.1 Screw tightening torques



For detailed information on the screw tightening torques, see the "Mounting the sensor" section of the Operating Instructions for the device

Note the following points:

- The torques listed only apply:
 - For lubricated threads.
 - For pipes that are free from tensile stress.
- Tighten the screws uniformly and in diagonally opposite sequence.
- Overtightening the screws will deform the sealing surface or damage the seal.

EN 1092-1 (DIN 2501), PN 6/10/16

Nominal diameter [mm]	Pressure rating [bar]	Screws [mm]	Flange thickness [mm]	Max. screw tightening torque [Nm]		
				Hard rubber	Polyurethane	PTFE
25	PN 10/16	4 × M12	18	–	6	11
32	PN 10/16	4 × M16	18	–	16	27
40	PN 10/16	4 × M16	18	–	16	29
50	PN 10/16	4 × M16	18	–	15	40
65 ¹⁾	PN 10/16	8 × M16	18	–	10	22
80	PN 10/16	8 × M16	20	–	15	30
100	PN 10/16	8 × M16	20	–	20	42
125	PN 10/16	8 × M16	22	–	30	55
150	PN 10/16	8 × M20	22	–	50	90
200	PN 16	12 × M20	24	–	65	87
250	PN 16	12 × M24	26	–	126	151
300	PN 16	12 × M24	28	–	139	177
350	PN 6	12 × M20	22	111	120	–
350	PN 10	16 × M20	26	112	118	–
350	PN 16	16 × M24	30	152	165	–
400	PN 6	16 × M20	22	90	98	–
400	PN 10	16 × M24	26	151	167	–
400	PN 16	16 × M27	32	193	215	–
450	PN 6	16 × M20	22	112	126	–
450	PN 10	20 × M24	28	153	133	–
500	PN 6	20 × M20	24	119	123	–

Nominal diameter [mm]	Pressure rating [bar]	Screws [mm]	Flange thickness [mm]	Max. screw tightening torque [Nm]		
				Hard rubber	Polyurethane	PTFE
500	PN 10	20 × M24	28	155	171	-
500	PN 16	20 × M30	34	275	300	-
600	PN 6	20 × M24	30	139	147	-
600	PN 10	20 × M27	28	206	219	-
600 ¹⁾	PN 16	20 × M33	36	415	443	-
700	PN 6	24 × M24	24	148	139	-
700	PN 10	24 × M27	30	246	246	-
700	PN 16	24 × M33	36	278	318	-
800	PN 6	24 × M27	24	206	182	-
800	PN 10	24 × M30	32	331	316	-
800	PN 16	24 × M36	38	369	385	-
900	PN 6	24 × M27	26	230	637	-
900	PN 10	28 × M30	34	316	307	-
900	PN 16	28 × M36	40	353	398	-
1000	PN 6	28 × M27	26	218	208	-
1000	PN 10	28 × M33	34	402	405	-
1000	PN 16	28 × M39	42	502	518	-
1200	PN 6	32 × M30	28	319	299	-
1200	PN 10	32 × M36	38	564	568	-
1200	PN 16	32 × M45	48	701	753	-
1400	PN 6	36 × M33	32	430	-	-
1400	PN 10	36 × M39	42	654	-	-
1400	PN 16	36 × M45	52	729	-	-
1600	PN 6	40 × M33	34	440	-	-
1600	PN 10	40 × M45	46	946	-	-
1600	PN 16	40 × M52	58	1007	-	-
1800	PN 6	44 × M36	36	547	-	-
1800	PN 10	44 × M45	50	961	-	-
1800	PN 16	44 × M52	62	1108	-	-
2000	PN 6	48 × M39	38	629	-	-
2000	PN 10	48 × M45	54	1047	-	-

Nominal diameter [mm]	Pressure rating [bar]	Screws [mm]	Flange thickness [mm]	Max. screw tightening torque [Nm]		
				Hard rubber	Polyurethane	PTFE
2 000	PN 16	48 × M56	66	1324	-	-
2 200	PN 6	52 × M39	42	698	-	-
2 200	PN 10	52 × M52	58	1217	-	-
2 400	PN 6	56 × M39	44	768	-	-
2 400	PN 10	56 × M52	62	1229	-	-

1) Designed acc. to EN 1092-1 (not to DIN 2501)

Nominal screw tightening torques for EN 1092-1 (DIN 2501); calculated according to EN 1591-1:2014 for flanges according to EN 1092-1:2013

Nominal diameter		Pressure rating [bar]	Screws [mm]	Flange thickness [mm]	Nom. screw tightening torque [Nm]		
[mm]	[in]				HR	PUR	PTFE
350	14	PN 6	12 × M20	22	60	75	-
		PN 10	16 × M20	26	70	80	-
		PN 16	16 × M24	30	125	135	-
		PN 25	16 × M30	38	230	235	-
400	16	PN 6	16 × M20	22	65	70	-
		PN 10	16 × M24	26	100	120	-
		PN 16	16 × M27	32	175	190	-
		PN 25	16 × M33	40	315	325	-
450	18	PN 6	16 × M20	22	70	90	-
		PN 10	20 × M24	28	100	110	-
		PN 16	20 × M27	34	175	190	-
		PN 25	20 × M33	46	300	310	-
500	20	PN 6	20 × M20	24	65	70	-
		PN 10	20 × M24	28	110	120	-
		PN 16	20 × M30	36	225	235	-
		PN 25	20 × M33	48	370	370	-
600	24	PN 6	20 × M24	30	105	105	-
		PN 10	20 × M27	30	165	160	-
600 ¹⁾	24	PN 16	20 × M33	40	340	340	-
600	24	PN 25	20 × M36	48	540	540	-

Nominal diameter		Pressure rating [bar]	Screws [mm]	Flange thickness [mm]	Nom. screw tightening torque [Nm]		
[mm]	[in]				HR	PUR	PTFE
700	28	PN 6	24 × M24	30	110	110	-
		PN 10	24 × M27	35	190	190	-
		PN 16	24 × M33	40	340	340	-
		PN 25	24 × M39	50	615	595	-
800	32	PN 6	24 × M27	30	145	145	-
		PN 10	24 × M30	38	260	260	-
		PN 16	24 × M36	41	465	455	-
		PN 25	24 × M45	53	885	880	-
900	36	PN 6	24 × M27	34	170	180	-
		PN 10	28 × M30	38	265	275	-
		PN 16	28 × M36	48	475	475	-
		PN 25	28 × M45	57	930	915	-
1000	40	PN 6	28 × M27	38	175	185	-
		PN 10	28 × M33	44	350	360	-
		PN 16	28 × M39	59	630	620	-
		PN 25	28 × M52	63	1300	1290	-
1200	48	PN 6	32 × M30	42	235	250	-
		PN 10	32 × M36	55	470	480	-
		PN 16	32 × M45	78	890	900	-
1400	-	PN 6	36 × M33	56	300	-	-
		PN 10	36 × M39	65	600	-	-
		PN 16	36 × M45	84	1050	-	-
1600	-	PN 6	40 × M33	63	340	-	-
		PN 10	40 × M45	75	810	-	-
		PN 16	40 × M52	102	1420	-	-
1800	72	PN 6	44 × M36	69	430	-	-
		PN 10	44 × M45	85	920	-	-
		PN 16	44 × M52	110	1600	-	-
2000	-	PN 6	48 × M39	74	530	-	-
		PN 10	48 × M45	90	1040	-	-
		PN 16	48 × M56	124	1900	-	-

Nominal diameter		Pressure rating [bar]	Screws [mm]	Flange thickness [mm]	Nom. screw tightening torque [Nm]		
[mm]	[in]				HR	PUR	PTFE
2200	-	PN 6	52 × M39	81	580	-	-
		PN 10	52 × M52	100	1290	-	-
2400	-	PN 6	56 × M39	87	650	-	-
		PN 10	56 × M52	110	1410	-	-

Abbreviations (liner): HR = hard rubber, PUR = polyurethane

1) Sizing as per EN 1092-1 (not DIN 2501)

ASME B16.5, Class 150

Nominal diameter		Screws [in]	Max. screw tightening torque [Nm] ((lbf · ft))		
[mm]	[in]		Hard rubber	Polyurethane	PTFE
25	1	4 × 5/8	-	5 (4)	14 (13)
40	1 ½	8 × 5/8	-	10 (7)	21 (15)
50	2	4 × 5/8	-	15 (11)	40 (29)
80	3	4 × 5/8	-	25 (18)	65 (48)
100	4	8 × 5/8	-	20 (15)	44 (32)
150	6	8 × ¾	-	45 (33)	90 (66)
200	8	8 × ¾	-	65 (48)	87 (64)
250	10	12 × 7/8	-	126 (93)	151 (112)
300	12	12 × 7/8	-	146 (108)	177 (131)
350	14	12 × 1	135 (100)	158 (117)	-
400	16	16 × 1	128 (94)	150 (111)	-
450	18	16 × 1 1/8	204 (150)	234 (173)	-
500	20	20 × 1 1/8	183 (135)	217 (160)	-
600	24	20 × 1 ¼	268 (198)	307 (226)	-

AWWA C207, Class D

Nominal diameter		Screws [in]	Max. screw tightening torque [Nm] ((lbf · ft))		
[mm]	[in]		Hard rubber	Polyurethane	PTFE
700	28	28 × 1 ¼	247 (182)	292 (215)	-
750	30	28 × 1 ¼	287 (212)	302 (223)	-
800	32	28 × 1 ½	394 (291)	422 (311)	-

Nominal diameter		Screws [in]	Max. screw tightening torque [Nm] ((lbf · ft))		
[mm]	[in]		Hard rubber	Polyurethane	PTFE
900	36	32 × 1 ½	419 (309)	430 (317)	-
1000	40	36 × 1 ½	420 (310)	477 (352)	-
1050	42	36 × 1 ½	528 (389)	518 (382)	-
1200	48	44 × 1 ½	552 (407)	531 (392)	-
1350	54	44 × 1 ¾	730 (538)	-	-
1500	60	52 × 1 ¾	758 (559)	-	-
1650	66	52 × 1 ¾	946 (698)	-	-
1800	72	60 × 1 ¾	975 (719)	-	-
2000	78	64 × 2	853 (629)	-	-
2150	84	64 × 2	931 (687)	-	-
2300	90	68 × 2 ¼	1048 (773)	-	-

AS 2129, Table E

Nominal diameter [mm]	Screws [mm]	Max. screw tightening torque [Nm]		
		Hard rubber	Polyurethane	PTFE
350	12 × M24	203	-	-
400	12 × M24	226	-	-
450	16 × M24	226	-	-
500	16 × M24	271	-	-
600	16 × M30	439	-	-
700	20 × M30	355	-	-
750	20 × M30	559	-	-
800	20 × M30	631	-	-
900	24 × M30	627	-	-
1000	24 × M30	634	-	-
1200	32 × M30	727	-	-

AS 4087, PN 16

Nominal diameter [mm]	Screws [mm]	Max. screw tightening torque [Nm]		
		Hard rubber	Polyurethane	PTFE
350	12 × M24	203	-	-
375	12 × M24	137	-	-

Nominal diameter [mm]	Screws [mm]	Max. screw tightening torque [Nm]		
		Hard rubber	Polyurethane	PTFE
400	12 × M24	226	-	-
450	12 × M24	301	-	-
500	16 × M24	271	-	-
600	16 × M27	393	-	-
700	20 × M27	330	-	-
750	20 × M30	529	-	-
800	20 × M33	631	-	-
900	24 × M33	627	-	-
1000	24 × M33	595	-	-
1200	32 × M33	703	-	-



71756802

www.addresses.endress.com
