

# Installation Instructions

## **Liquiline System CA8x analyzer**

Process engineering



**Table of contents**

1 Overview ..... 3

2 Intended use ..... 13

3 Personnel authorized to carry out modifications ..... 13

4 Safety instructions ..... 13

5 Scope of delivery ..... 16

6 Replacing the components ..... 25

















7 Additional documentation ..... 43

8 Disposal ..... 43

# 1 Overview

## 1.1 Spare parts kits

These installation instructions apply to the following spare parts kits:

Order code	Description	Page
71420354	CA8x photometer module V2.x	→  16
71218490	CA8x linear drive	→  16
71222105	CA8x dispenser holders 10 ml	→  17
71222106	CA8x dispensers 10 ml	→  17
71222108	CA8x dispenser holders 2.5 ml	→  18
71222107	CA8x dispensers 2.5 ml	→  18
71218491	CA8x light barrier, linear drives V1	→  20
71465074	CA8x light barrier, linear drive V2	→  19
71218492	CA8x Liquid Manager, complete	→  20
71339718	CA8x 3 Reag: Liquid Manager, complete	→  22
71299073	CA8x Liquid Manager without motor	→  20
71339723	CA8x 3 Reag: Liquid Manager without motor	→  22
71218493	CA8x stepping motor, Liquid Manager	→  23
71218487	CA8x carrier plate cover	→  23
71218504	CA8x control module version 1	→  24
71503207	CA8x control module version 2	→  24

## 1.2 Overview of CA8x device types

### 1.2.1 Overview of CA80 single parameters (CA80AL/AM/CR/FE/HA/NO/PH)

The figures below show an overview of the CA80 for the colorimetric single parameter measurement:

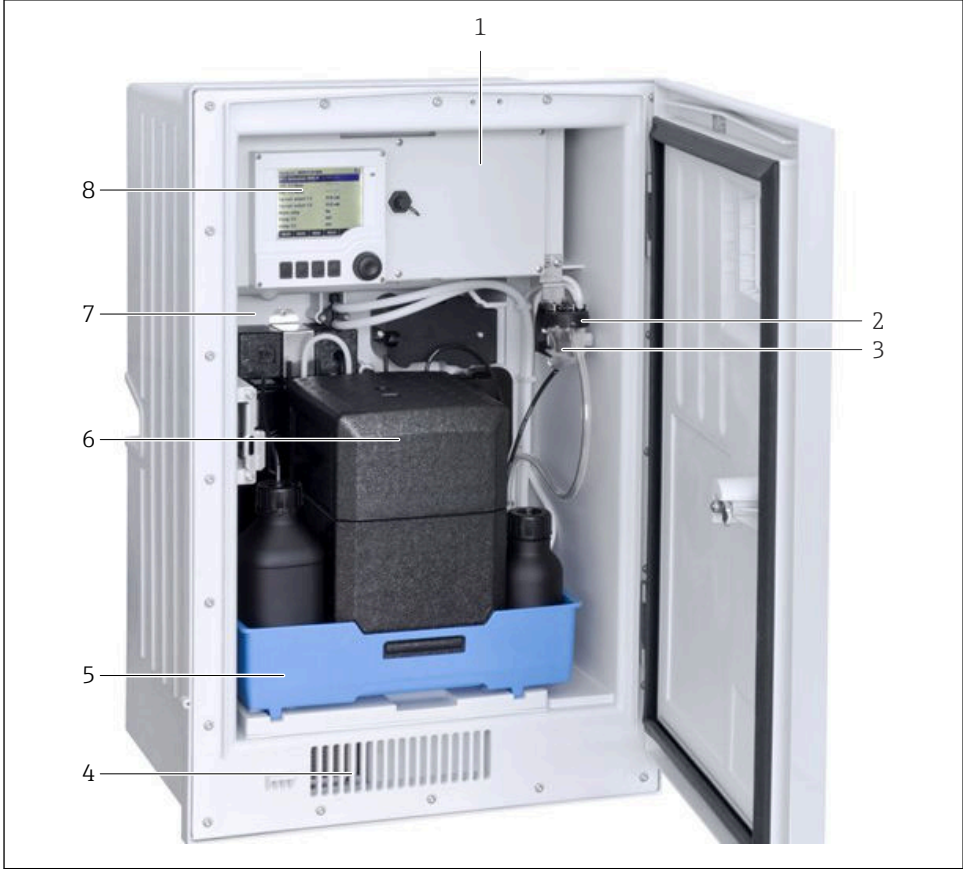

A0057624

**1** Overview of single parameters for CA80 assemblies

- 1 Electronics compartment cover
- 2 Solenoid valve (only for 2x sample collector)
- 3 Sample collector (depending on version ordered)
- 4 Ventilation/cooling
- 5 Bottle holder
- 6 Insulation (optional, only for cooling)
- 7 Process module (carrier plate with Liquid Manager, photometer and control module)
- 8 Measuring and control unit (controller)

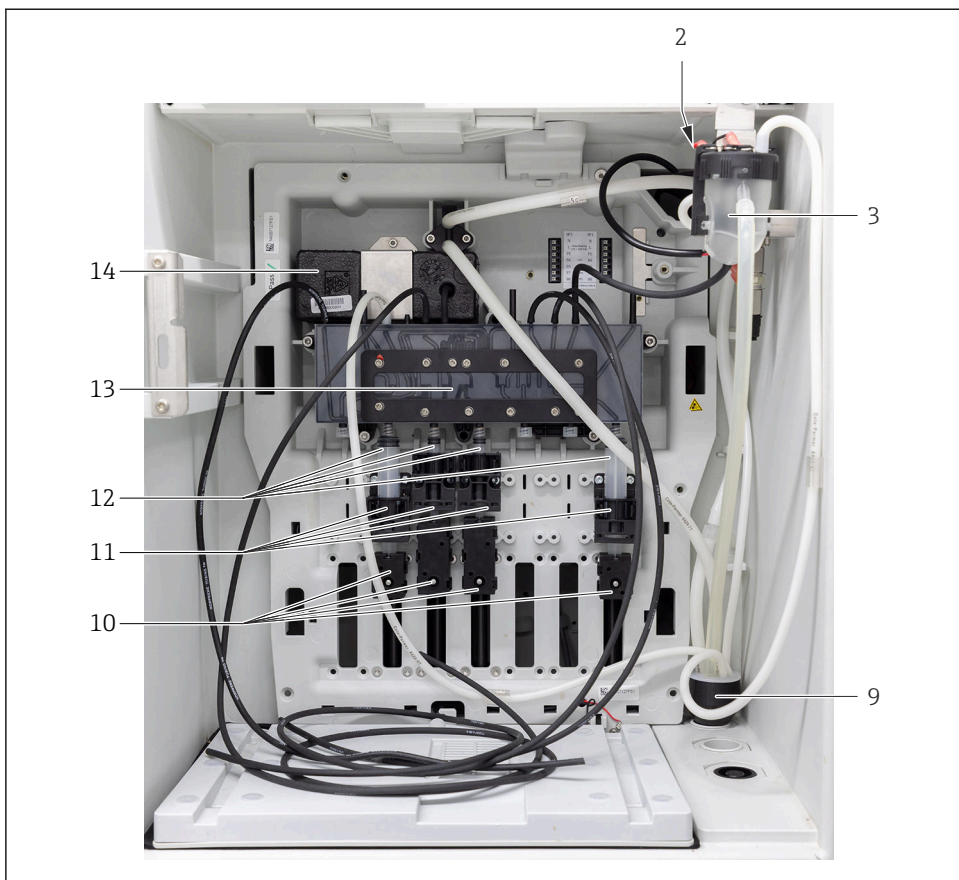

A0056794

2 Carrier plate for CA80 single parameters

- 9 Drain pipe
- 10 Linear drives
- 11 Dispenser holders
- 12 Dosing dispensers
- 13 Liquid Manager
- 14 Photometer

### 1.2.2 Overview of CA80 sum parameters (CA80COD/TP)

The figures below show an overview of the CA80 for the colorimetric sum parameter measurement.



A0057629

#### 3 Assembly overview of CA80COD sum parameters

- 1 Electronics compartment
- 2 Carrier plate
- 3 Cooling (option for CA80TP)
- 4 Bottle tray for reagents and standard
- 5 Measuring and control unit (controller)

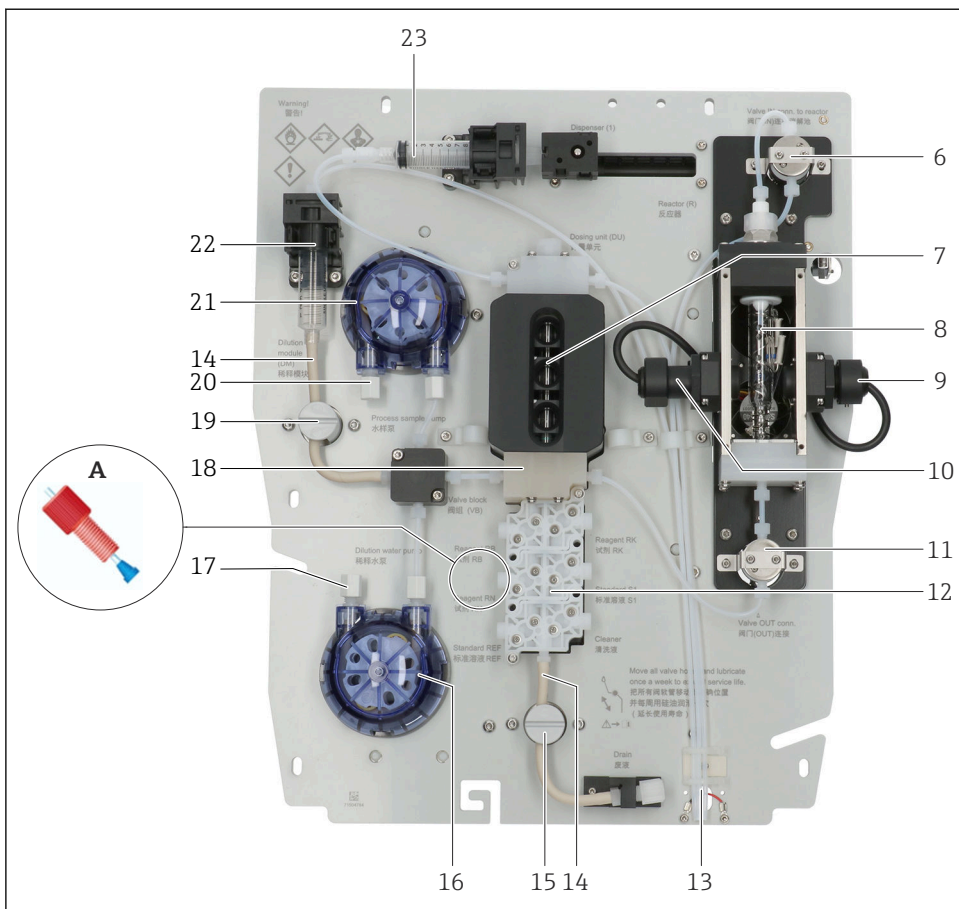

A0058781

4 Carrier plate CA80 sum parameters (remove safety cover!)

A Handling the glands with the cone: Observe the installation direction of the cone!

6 Reactor valve at top

7 Dosing unit with dosing tubes

8 Reactor with reactor cuvette

9 Photometer (receiver module)

10 Photometer (transmitter module)

11 Reactor valve at bottom

12 Valve block

13 Leak sensor

14 Pharmed® hose for pinch valve

15 Waste valve

16 Dilution pump (only with high measuring range)

17 Dilution water intake

18 Valve block with dosing unit

19 Dilution water valve

- 20 *Sample intake*
- 21 *Sample pump*
- 22 *Dilution module (only with high measuring range)*
- 23 *Dosing dispenser*



### 1.2.3 Overview of CA80SI/82HA

The figures below show an overview of the CA80SI/82HA for photometric silicate measurement or to measure water hardness in the low validity range. A 2-channel device is shown.

For 2-channel devices, the sample switch is integrated into the device. Filters and pressure limiters are mounted externally.

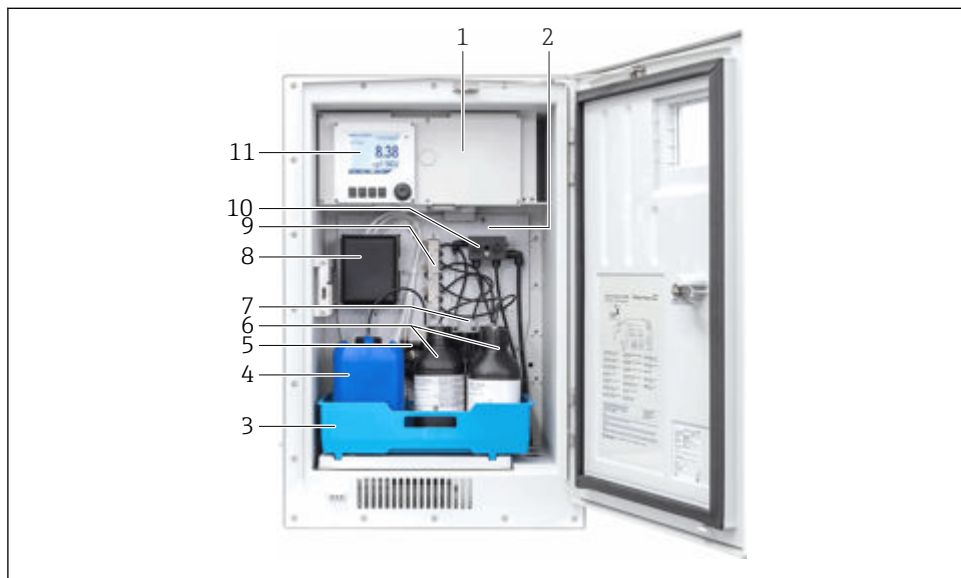

A0057631

#### 5 CA80SI/82HA assembly overview

- 1 Electronics compartment cover
- 2 Carrier plate
- 3 Bottle tray
- 4 Bottle for standard solution
- 5 Peristaltic pump for standard solution
- 6 Reagent bottles
- 7 Dosing dispensers for reagents
- 8 Cover with cuvette, photometer and stirrer behind
- 9 Valve block for reagent dosing
- 10 Sample switch (only 1-channel/2-channel devices)
- 11 Measuring and control unit (controller)

The figure below shows the carrier plate from the front.

For 4-channel/6-channel devices, the sample switch is outside the analyzer.

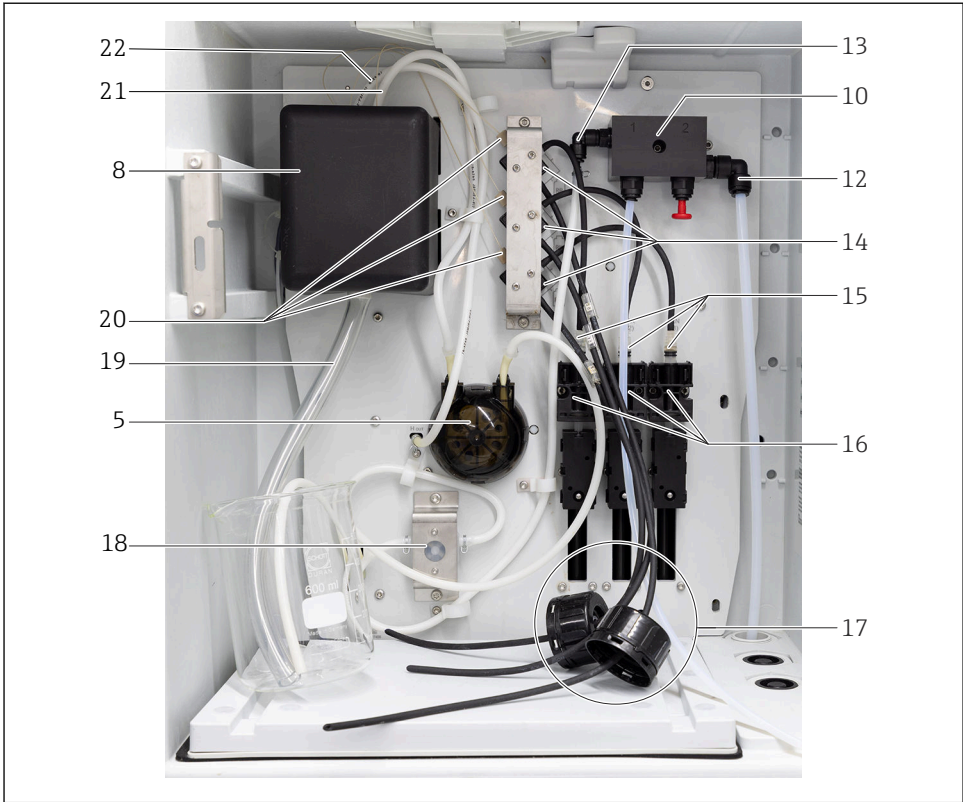

A0058795

**6** CA80SI/82HA carrier plate

- 12 Drain hose sample switch OD 8 mm
- 13 Sample hose for 1-channel/2-channel devices to heater
- 14 Valves for reagents
- 15 Dosing dispensers
- 16 Dispenser holders
- 17 Cover of reagent container with hoses
- 18 Flowmeter
- 19 Drain hose, cuvette ID 13 mm
- 20 Capillaries for reagents
- 21 Sample hose (from heater)
- 22 Hose standard solution

### 1.2.4 Overview of CA80TN (total nitrogen)

The figures below show an overview of the CA80TN for the photometric measurement of the total nitrogen.



A0057730

#### 7 CA80TN assembly overview

- 1 Electronics compartment cover
- 2 Carrier plate
- 3 Peristaltic pump
- 4 Valve block for reagent dosing
- 5 Bottle tray for reagents, sample + standard
- 6 Reactor (behind protective cover)
- 7 Protective cover
- 8 Measuring and control device

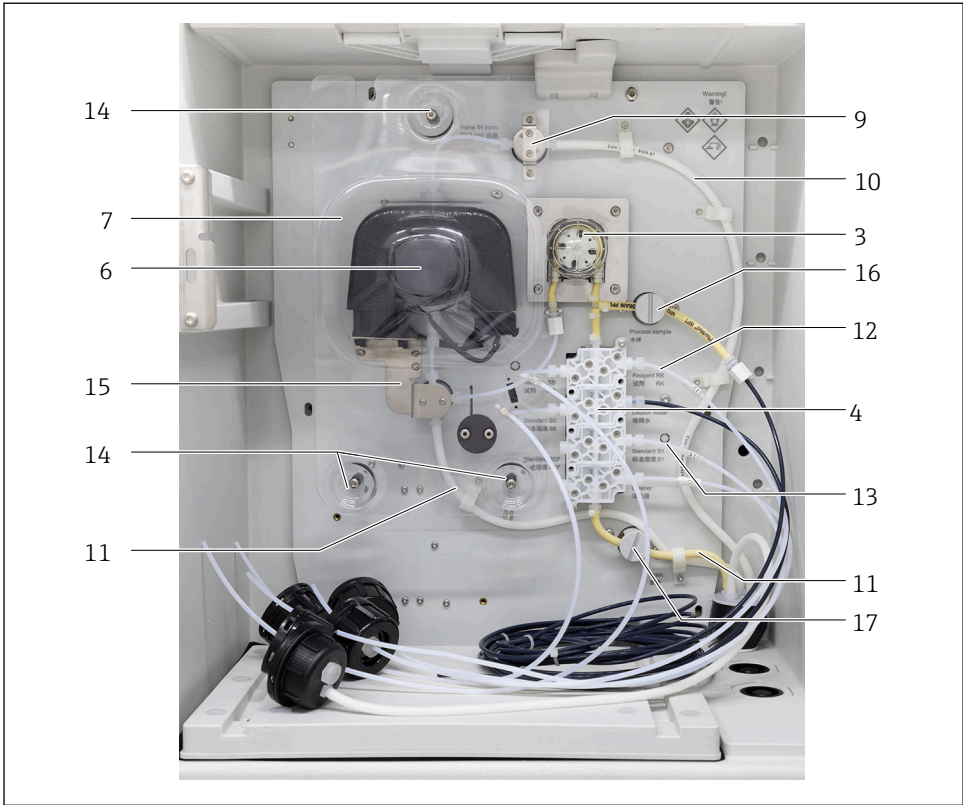

A0059726

8 CA80TN carrier plate

- 9 Vent valve
- 10 Ventilation hose
- 11 Drain hoses
- 12 Sample hose
- 13 Dilution water hose
- 14 Screws of protective cover
- 15 Reactor valve
- 16 Sample valve
- 17 Drain valve

## 2 Intended use

- The parts of the kits must only be used as spare parts for CA80xx analyzers. Any other use is not permitted!
- An overview of the structure of the main device types can be found in the section "Overview of CA80 device types" (→  4).
- All replacement descriptions for the kits refer to the "CA80 individual parameter" device type (CA80AL/AM/CR/FE/HA/NO/PH).
- The device types CA80COD, CA80TP, CA80TN, CA80SI and CA82HA each have different carrier board structures. The respective replacement instructions must be applied accordingly.
- Use only original parts from Endress+Hauser.
- In the Device Viewer, check if the spare part is suitable for the device in question.

## 3 Personnel authorized to carry out modifications

- Installation, commissioning, operation and maintenance of the measuring system may be carried out only by specially trained technical personnel.
- The technical personnel must be authorized by the plant operator to perform the stated tasks.
- The electrical connection may only be established by an electrical technician.
- The technical personnel must have read and understood these Installation Instructions and must follow the instructions they contain.
- Measuring point faults may be repaired only by authorized and specially trained personnel.
- In the case of Ex-certified devices, the technical staff must also be trained in explosion protection.

 Repairs not described in the Operating Instructions provided must only be carried out directly at the manufacturer's site or by the service organization.

## 4 Safety instructions

### WARNING

#### Risk of electric shock!

- ▶ Perform work on the device with the utmost caution, especially when the device remains fully or partially powered on during maintenance tasks.
- ▶ Follow the instructions in the relevant sections of this manual, as the procedure for electrical safety depends on the service kits used. The device does not have a power switch for the power supply.
- ▶ All work must be carried out according to applicable safety standards.
- ▶ Note the instructions in the Operating Instructions for the analyzer.

**⚠ CAUTION****Risk to health due to contact with reagents, chemicals or process solutions!**

- ▶ Wear protective gloves, protective goggles and protective clothing.
- ▶ Immediately rinse splashes with plenty of water and a 1% sodium bicarbonate solution ( $\text{NaHCO}_3$ , baking soda).
- ▶ In case of eye contact, rinse the affected area with plenty of water and then seek medical advice. Show the relevant safety data sheet to the physician.
- ▶ Note the nationally applicable workplace safety regulations for the work area when handling toxic or corrosive chemicals.

**⚠ CAUTION****Electronic assemblies are sensitive to electrostatic discharges (ESD)!**

- ▶ Before removing an assembly from the antistatic packaging, it must be discharged, e.g. at a protective ground. Continuous grounding, e.g. with an ESD wristband, is recommended.

**Potential impact on the process**

Before decommissioning an active device, the potential impact on the overall process must be taken into account! This applies in particular when using the switching contacts, the analog signal outputs or the communication interface of the associated measuring instrument to control process variables. Coordinate service tasks with the operator!



Contact Endress+Hauser Service if you have questions: [www.addresses.endress.com](http://www.addresses.endress.com)

## 4.1 Compatibility of the electrical assemblies

If one of the modules specified in the table below needs to be replaced, care must be taken to use a module of the same version. A device's generation of modules can be determined in the Asset Central Viewer (ACV).

Electronic modules of Version 1 are not compatible with electronic modules of Version 2. This means that a device can only contain either Version 1 modules or Version 2 modules, but not a mix of both. The table shows the compatibility of modules.

Version 2 of the electronics modules is only supported by firmware 01.08.00 and later!

	Backplane V1	BASE-E	Interface module V1	Control module V1	Backplane V2	BASE2-E	Interface module V2	Control module V2
Backplane V1	N/A	☑	☑	☑	N/A	-	-	-
BASE-E	☑	N/A	☑	☑	-	N/A	-	-
Interface module V1	☑	☑	N/A	☑	-	-	N/A	-
Control module V1	☑	☑	☑	N/A	-	-	-	N/A
Backplane V2	N/A	-	-	-	N/A	☑	☑	☑
BASE2-E	-	N/A	-	-	☑	N/A	☑	☑
Interface module V2	-	-	N/A	-	☑	☑	N/A	☑
Control module V2	-	-	-	N/A	☑	☑	☑	N/A

## 5 Scope of delivery

### 5.1 71420354 Kit CA8x photometer module V2.x



Pay attention to the labeling (1) on the photometer. For article number 71309400, at least SW version 1.06.08 is required. For article number 71685524, at least SW version 1.15.0 is required.

The kit contains the following parts → 9, 16:

1 x Photometer, complete

1 x Kit instructions

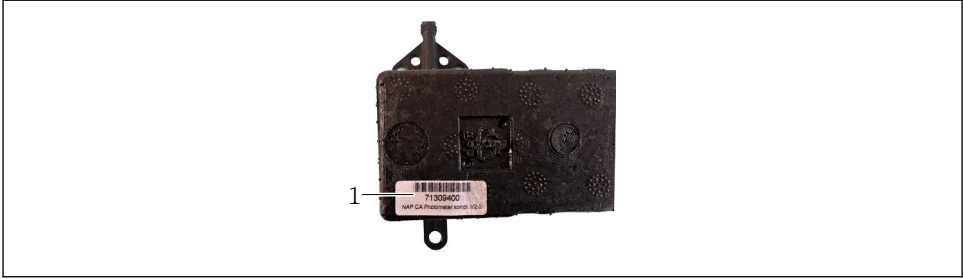

A0057828

9 CA8x photometer module V2.x

### 5.2 71218490 kit CA8x linear drive, complete

The kit contains the following parts → 10, 16:

1 x Linear drive, complete

1 x Kit instructions

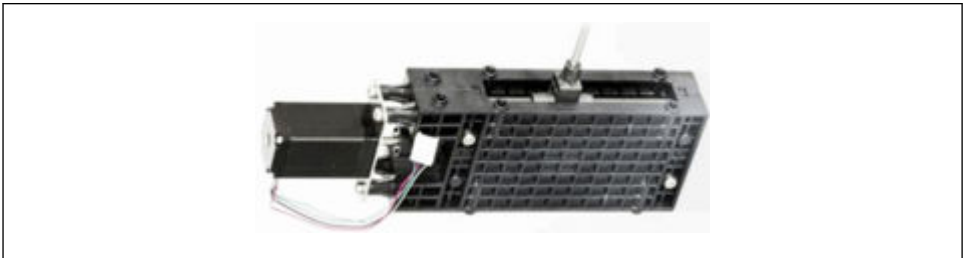

A0057609

10 Linear drive, complete



### 5.3 71222105 kit CA8x dispenser holders 10 ml

The kit contains the following parts →  11,  17:

- |      |                                 |     |                  |
|------|---------------------------------|-----|------------------|
| 10 x | Long dispenser guide, for 10 ml | 1 x | Kit instructions |
| 10 x | Long base for dispenser guide   |     |                  |

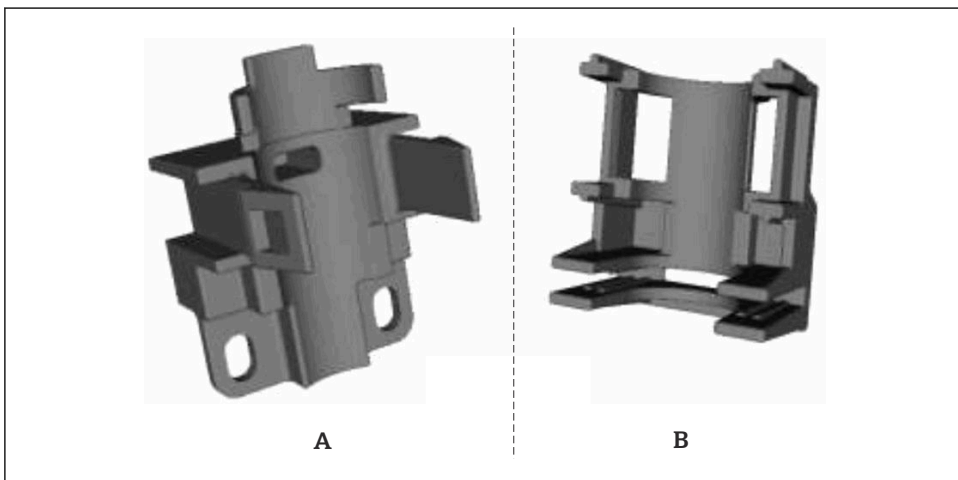

A0057610

 11 *Dispenser holder 10 ml*

A *Long base for dispenser guide*

B *Long dispenser guide*

### 5.4 71222106 kit CA8x dispensers 10 ml

The kit contains the following parts →  12,  17:

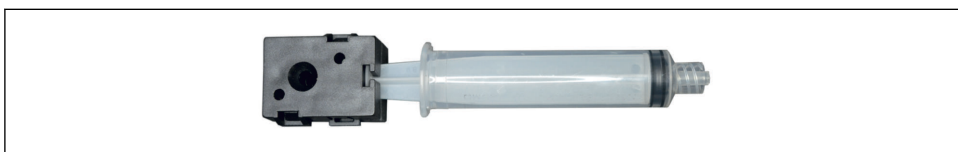

- |      |                                     |     |                  |
|------|-------------------------------------|-----|------------------|
| 20 x | Disposable dispenser 10 ml, cleaned | 1 x | Kit instructions |
| 20 x | Adapter (two-part) 10 ml            |     |                  |



A0059896

 12 *10 ml dispensers*

## 5.5 71222108 kit CA8x dispenser holders 2.5 ml

The kit contains the following parts →  13,  18:

- |      |                                   |     |                  |
|------|-----------------------------------|-----|------------------|
| 10 x | Short dispenser guide, for 2.5 ml | 1 x | Kit instructions |
| 10 x | Short base for dispenser guide    |     |                  |

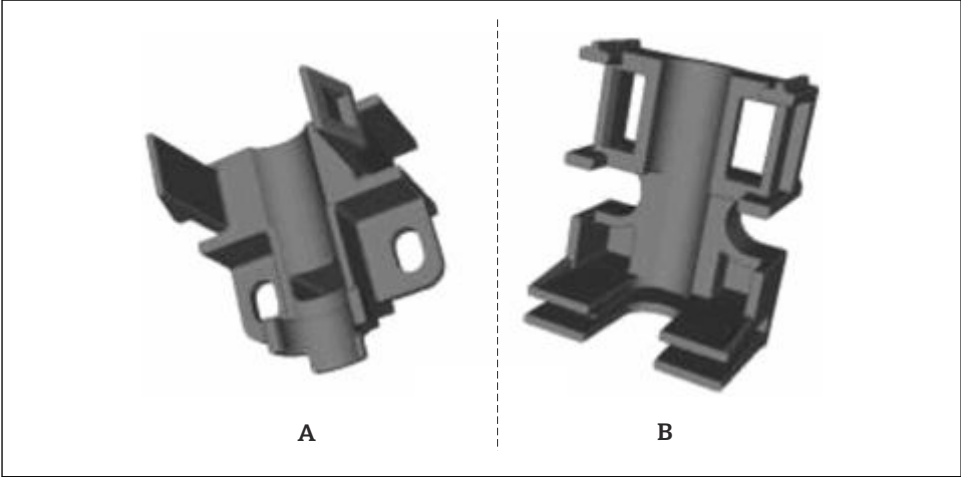



A0057612

 13 *Dispenser holder 2.5 ml*

A *Short base for dispenser guide*

B *Short dispenser guide*

## 5.6 71222107 kit CA8x dispensers 2.5 ml

The kit contains the following parts →  14,  18:

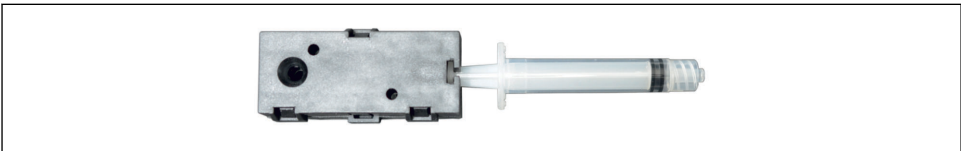

- |      |                                      |     |                  |
|------|--------------------------------------|-----|------------------|
| 20 x | Disposable dispenser 2.5 ml, cleaned | 1 x | Kit instructions |
| 20 x | Adapter (two-part) 2.5 ml            |     |                  |



A0059895

 14 *2.5 ml dispensers*

## 5.7 71465074 kit CA8x light barrier for linear drive V2

The kit contains the following parts →  15,  19:

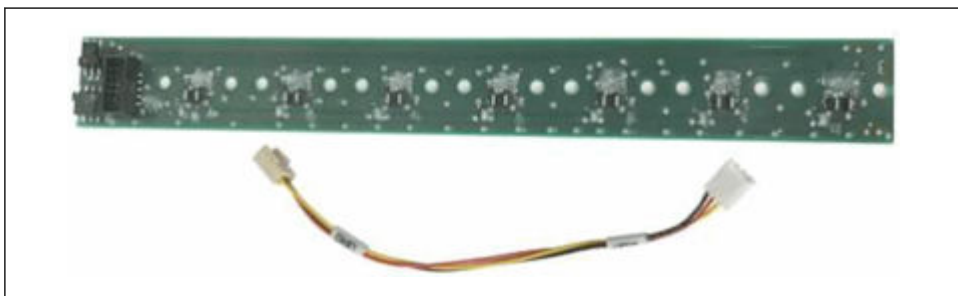

- |     |                                      |     |                  |
|-----|--------------------------------------|-----|------------------|
| 1 x | Light barriers module FILB1 Vx.04.xx | 1 x | Kit instructions |
| 1 x | Connection cable                     |     |                  |



A0057617

 15 *Light barrier for linear drive V2*

## 5.8 71218491 kit CA8x light barrier for linear drives V1

The kit contains the following parts →  16,  20:

1 x Light barriers module FILB1 Vx.01.00                      1 x Kit instructions

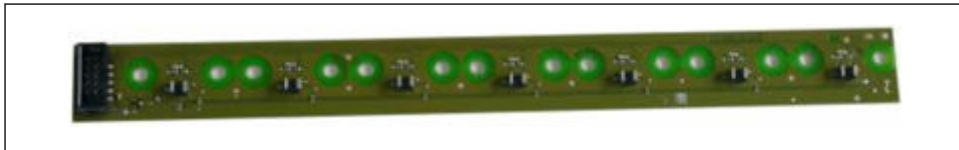



A0057618

 16 *Light barrier for linear drives V1*



## 5.9 Liquid Manager 1/2 reagents

### 5.9.1 71218492 Kit CA8x Liquid Manager complete with motor, for 1 or 2 reagents

The kit contains the following parts →  17,  21:

1 x Liquid Manager for 1 or 2 reagents (2R), with motor, including Luer sealing plugs and EPDM sealing caps                      1 x Kit instructions

### 5.9.2 71299073 kit CA8x Liquid Manager without motor, for 1 or 2 reagents

The kit contains the following parts →  17,  21:

1 x Liquid Manager for 1 or 2 reagents (2R), without a motor, including Luer sealing plugs and EPDM sealing caps                      1 x Kit instructions

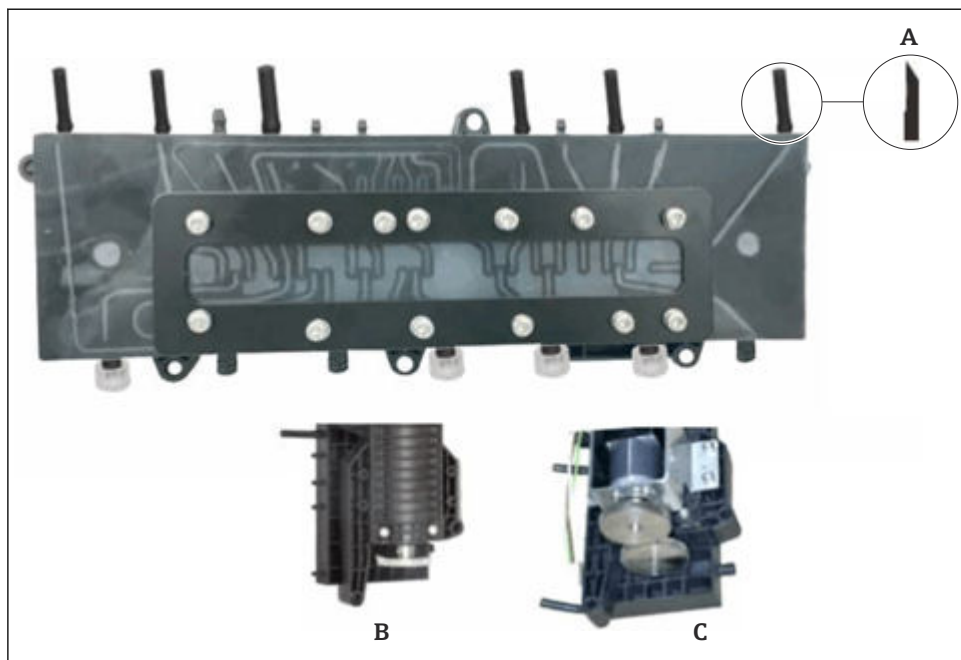



A0057619

17 Liquid Manager for 1 or 2 reagents (2R)

- A For CA80FE, CA80HA-B: Cap must be open, cut at an angle!
- B Rear view, version without motor
- C Rear view, version with motor



## 5.10 Liquid Manager 3 reagents

### 5.10.1 71339718 kit CA8x 3 reagents, Liquid Manager, complete, with motor

The kit contains the following parts →  18,  22:

- |     |  |     |                  |
|-----|--|-----|------------------|
| 1 x | Liquid Manager for 3 reagents (3R), with motor, including Luer sealing plugs and EPDM sealing caps | 1 x | Kit instructions |
|-----|--|-----|------------------|

### 5.10.2 71339723 kit CA8x 3 reagents Liquid Manager without motor

The kit contains the following parts →  18,  22:

- |     |   |     |                  |
|-----|---|-----|------------------|
| 1 x | Liquid Manager for 3 reagents (3R), without motor, including Luer sealing plugs and EPDM sealing caps | 1 x | Kit instructions |
|-----|---|-----|------------------|

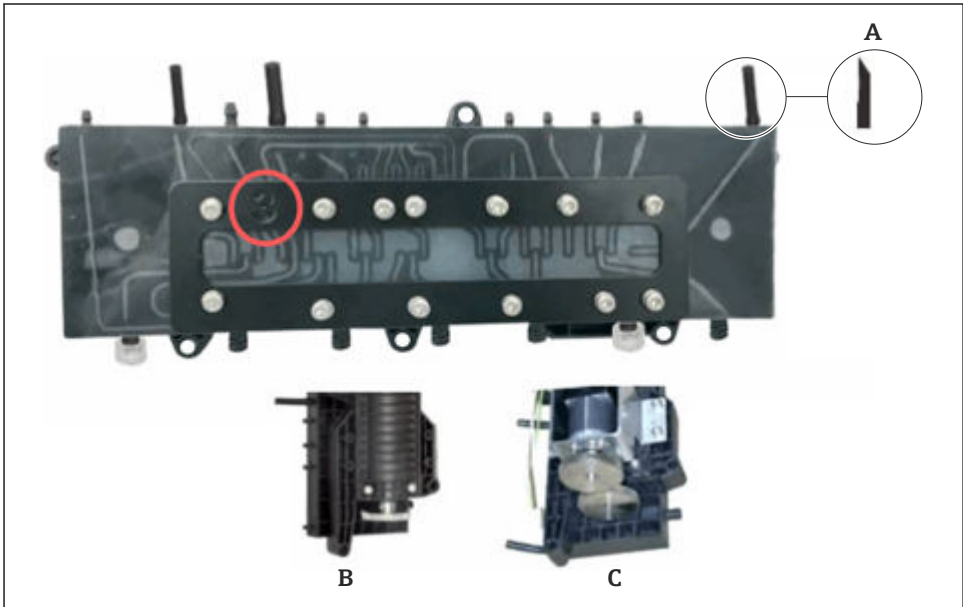

A0057620

#### 18 Liquid Manager for 3 reagents (3R)

- A For CA80AL: Cap must be open, cut at an angle!  
 B Rear view, version without motor  
 C Rear view, version with motor

## 5.11 71218493 kit CA8x stepping motor for Liquid Manager

The kit contains the following parts →  19,  23:

1 x	Stepping motor with gear drive	1 x	Cog
1 x	Motor holder	1 x	Kit instructions

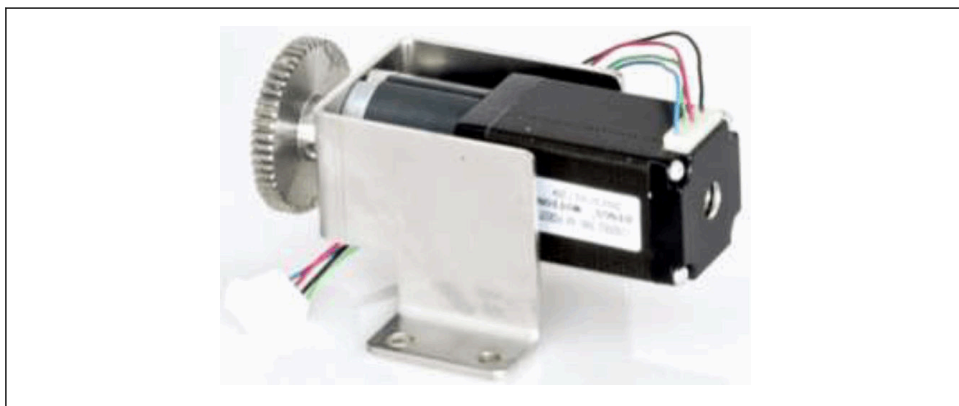

A0057621

 19 *Stepping motor for Liquid Manager*

## 5.12 71218487 kit CA8x cover for carrier plate

The kit contains the following parts →  20,  23:

1 x	Lasered carrier plate cover	1 x	Kit instructions
-----	-----------------------------	-----	------------------

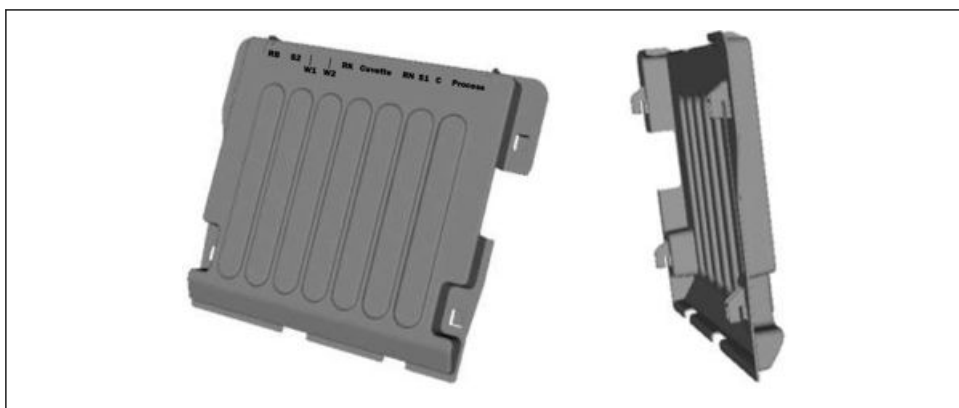



A0057622

 20 *Cover for carrier plate*

## 5.13 71218504 kit CA8x control module version 1



Detailed view of V1 →  36,  39 control module.

The kit contains the following parts →  21,  24:

1 x Control module version 1 (FXAB1)                      1 x Kit instructions

## 5.14 71503207 kit CA8x control module version 2

Detailed view of V2 →  38,  41 control module.

The kit contains the following parts →  21,  24:

1 x Control module version 2 (FXAB2)                      1 x Kit instructions

1 x Labeled cover (parameter-specific)

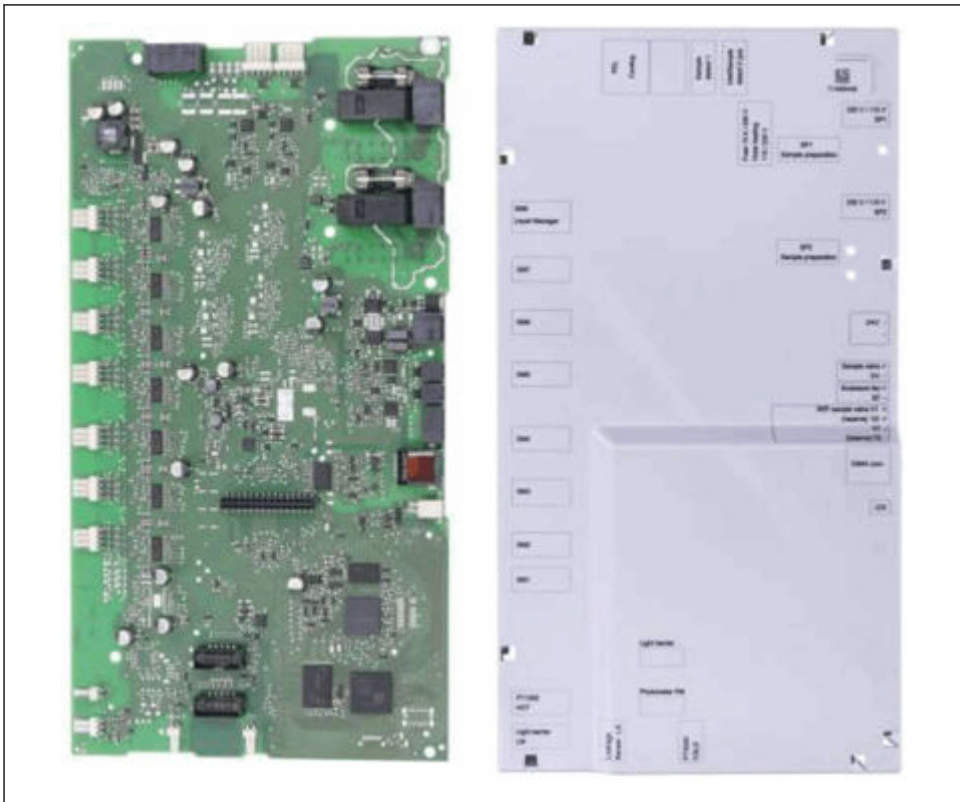

A0057623

 21 Control module and cover (V2 as an example)



## 6 Replacing the components

### 6.1 Preparation

The spare part installation differs depending on the spare part and parameters. Therefore, refer to and differentiate between the following sections.

#### 6.1.1 Work without removing the chemical containers = replacing modules/ components in the electronics compartment

1. Select **Mode** → **Manual mode** and confirm by pressing the navigator button.
2. Wait until the analyzer has finished the measurement and **Manual** is displayed as the **Current mode**.
3. **Disconnect the analyzer from the power supply and secure the circuit breaker against unintentional recommissioning.**

#### 6.1.2 Work with removal of chemical containers = replacing components on or behind the carrier plate for CA80AL/AM/CR/FE/HA/NO/PH

1. Select **Mode** → **Manual mode** and confirm by pressing the navigator button.
2. Wait until the analyzer has finished the measurement and **Manual** is displayed as the **Current mode**.
3. Stop the sample feed.
4. Select **Menu** → **Operation** → **Maintenance** → **Decommissioning** → **Sample collector** → **Empty sample collector**. Wait until the sample collecting vessel is empty.
5. Remove all the hoses from the reagent bottles. Wipe the ends of the hoses with a clean paper towel and place the hoses in an empty beaker. Select the entry **Rinse with water**. The system is cleaned with air.



The software evaluates this as the bottles being removed. Therefore, they need to be reinserted at a later time.

6. Then place the hoses in a beaker containing distilled or ultrapure water.
7. Also disconnect the black sample hose “P” from the sample collecting vessel and place it in the beaker.
8. Select **Menu** → **Operation** → **Maintenance** → **Decommissioning** → **Rinse with water**. Wait until flushing is finished.
9. Place the hoses back into an empty beaker and flush again with air by selecting the **Rinse with water** entry.



All the hoses are now flushed, clean and filled with air. It is now possible to work on the analyzer without risk.

10. **Disconnect the analyzer from the power supply and secure the circuit breaker against unintentional recommissioning.**

### 6.1.3 Work with removal of the chemical containers = replacement of components on or behind the carrier plate for CA80COD/TP/SI/TN

1. Select **Mode** → **Manual mode** and confirm by pressing the navigator button.
2. Wait until the analyzer has finished the measurement and **Manual** is displayed as the **Current mode**.
3. Stop the sample feed.
4. Remove the hoses for reagents, the sample and, if necessary, the dilution water from their sampling points. Wipe the ends of the hoses with a clean paper towel.
5. Place the hoses in an empty beaker and select **Menu** → **Operation** → **Maintenance** → **Decommissioning** → **Empty hoses**.



The software evaluates this as the bottles being removed. Therefore, they need to be reinserted at a later time.

6. Place the hoses in a beaker with distilled or ultrapure water and select **Menu** → **Operation** → **Maintenance** → **Decommissioning** → **Rinse with water**. Wait until flushing is finished.
7. Place the hoses back in an empty beaker and select **Menu** → **Operation** → **Maintenance** → **Decommissioning** → **Empty hoses**.



All the hoses are now flushed, clean and filled with air. It is now possible to work on the analyzer without risk.

8. **Disconnect the analyzer from the power supply and secure the circuit breaker against unintentional recommissioning.**

## 6.2 Replacing dispensers and dispenser holders

1. Carry out the preparatory work according to Section 6.1.2 or 6.1.3 → 25 (depending on the type of analyzer).
2. Remove the bottle tray.
3. Open the **Menu** → **Operation** → **Maintenance** → **Dispenser replacement**.
4. Open **Dispenser selection** (not necessary for CA80COD and CA80TP since only one dispenser is present).
5. Select the dispensers that should be replaced (not necessary for CA80COD and CA80TP since only one dispenser is present).
6. Confirm selection by pressing **OK** (not necessary for CA80COD and CA80TP since only one dispenser is present).
7. Select **Draw up dispenser** to move the dispenser to the lower position.
8. Open the dispenser holder. Only the top part of the dispenser holder is attached.
9. Turn the dispenser counterclockwise to remove it from the Liquid Manager.
10. Pull the dispenser adapter with the dispenser from the dispenser drive.

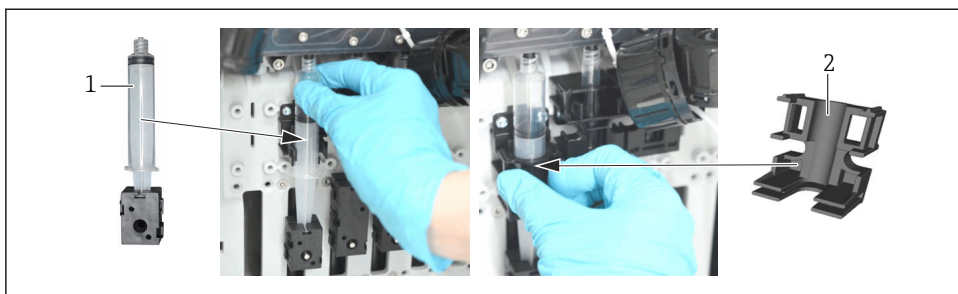

A0057732

## 22 Replacing the dispensers

- 1 Dispenser with adapter
- 2 The top of the dispenser holder for snap-on mounting

### Replace the old dispenser with a new dispenser:

11. Secure new dispensers to the Liquid Manager; to do so, fasten the dispensers on the thread by hand. The figures below show all the dispenser sizes (large and small).
12. First, make a complete turn (360°) by hand.

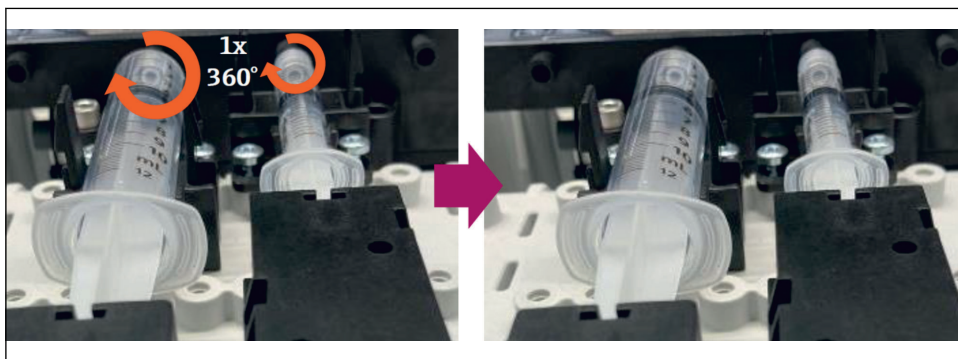

A0057899

## 23 Turning the dispensers 360°

13. Then also turn the dispensers by 45°. The dispensers are now in the correct end position. Please refer to the installation instructions below!

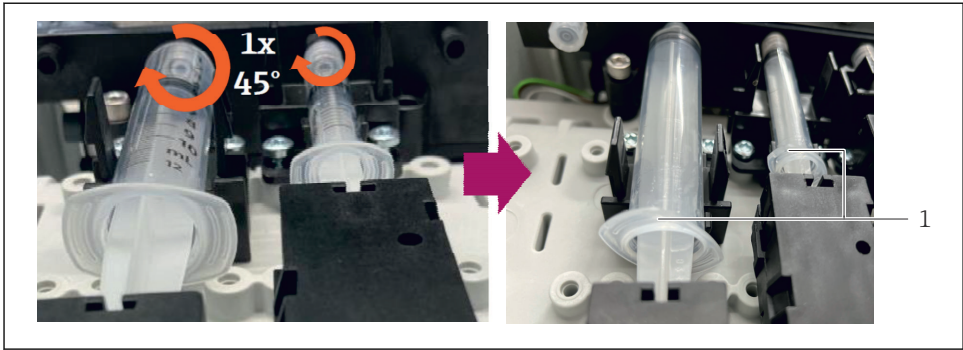

A0057900

☒ 24 Turning the dispensers by 45°

1 End position

14. Push the dispenser adapter into the dispenser drive.

15. Close the dispenser holder.

**i** The end of the dispenser must be parallel to the Liquid Manager, otherwise the dispenser holder (see → ☒ 22, ☒ 27, right) cannot be closed.

**i** The dispensers (small and large) must not be tightened as far as they will go. There must be a gap between the Liquid Manager and the dispenser (see the figure below, right side)!

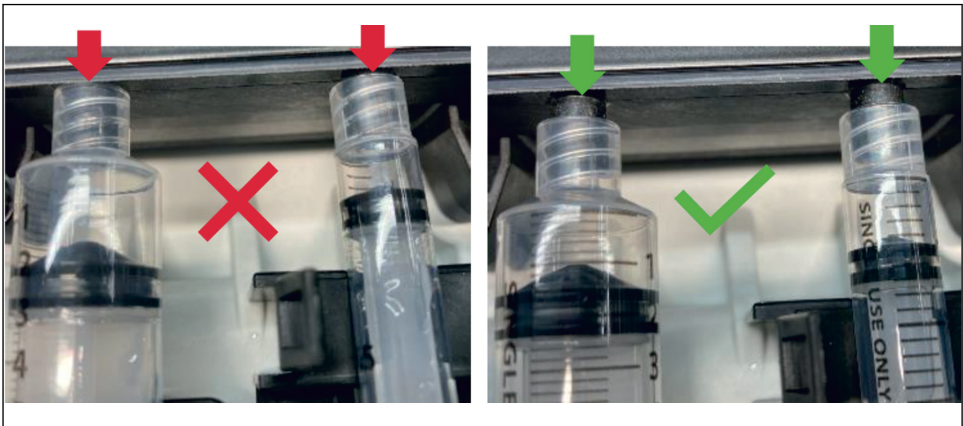

A0057901

☒ 25 Correct positioning





## 6.3 Replacing the Liquid Manager

1. Carry out preparatory work as per section 6.1.2 →  25.
2. Remove the bottle tray.
3. Disconnect all the hoses.
4. Remove all the dispensers.
5. Undo the mounting screws (4 screws with 4 mm hex head).
6. Disconnect the two connectors from the carrier plate. The connectors are guided from the rear through the carrier plate such that it is not necessary to fold the carrier plate forward.
7. Remove the Liquid Manager.
8. Adapt the number of protective caps and Luer plugs to the new Liquid Manager (for the required connections, see the removed Liquid Manager or hose connection diagrams).
9. **Only for Liquid Manager without motor:** Undo the four Torx T20 screws on the stepping motor mounting bracket on the old Liquid Manager. Then mount the motor on the new Liquid Manager.
10. Install the new Liquid Manager in the reverse order.

## 6.4 Replacing the photometer module

1. Carry out preparatory work as per section 6.1.2 →  25.
2. Disconnect the sample preparation from CA8x (disconnect all hoses and cables).
3. Disconnect the hoses on the Liquid Manager.
4. Remove all the dispensers.

### Remove the Liquid Manager:

1. Remove the mounting screws (4 Allen screws, 4 mm).
2. Disconnect the two connectors on the carrier plate. The connectors are guided from the rear through the carrier plate such that the carrier plate does not need to be folded forward.
3. Remove the screws of the photometer module holding bracket (5 Allen screws, 3 mm).
4. Remove the screws of the carrier plate (6 Allen screws, 3 mm).
5. Fold the carrier plate forward (→  26,  30).
6. Release the connectors of the photometer cable (left on control module, see →  26,  30 and also the control module cover labeling).
7. Replace the photometer module and complete the device again in the reverse order.

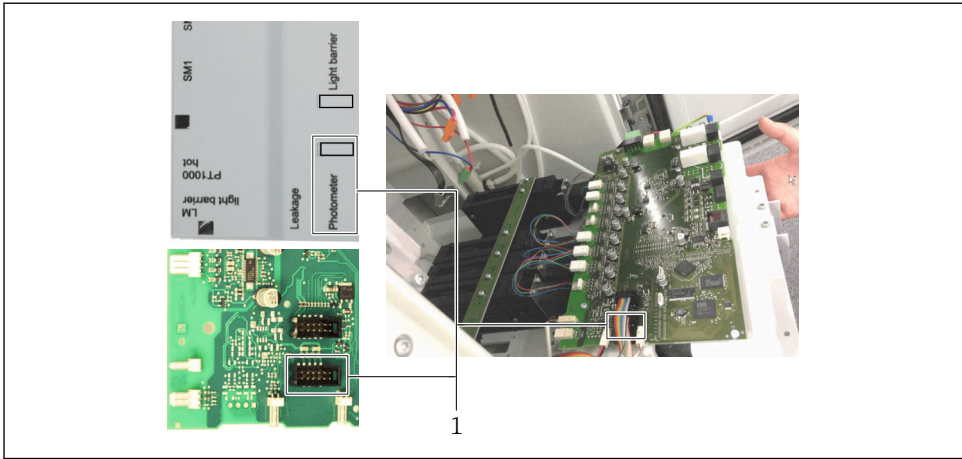

A0057733

26 Carrier plate with control module

1 Photometer connectors



## 6.5 Replacing the linear drive and light barriers module

### 6.5.1 Versions of light barriers module

- Previous version: Light barrier V1 with module FILB1 Vx.01.00, replacement kit = 71218491.
- Current version: Light barrier V2 with module FILB1 Vx.04.00, replacement kit = 71465074.
- Compatibility: Both light barriers modules are compatible in principle, but the different connections must be taken into account.
- **Instructions for replacement:**
  - Preparatory work, see Section 6.5.2 → 30.
  - For replacing the linear drive or light barriers module version V2, see Section 6.5.3 → 31.
  - For replacing light barriers module version V1, see Section 6.5.4 → 34.
  - For modifying light barriers module version V1 to the new V2 version, see Section 6.5.5 → 35.

### 6.5.2 Preparatory work for replacing the light barriers module or linear drives

1. Carry out preparatory work as per section 6.1.2 → 25.
2. Disconnect the sample preparation from CA8x (hoses and cables).
3. Remove all the hoses and remove all the dispensers.
4. Remove the screws of the carrier plate (6 Allen screws, 3 mm).
5. Fold the carrier plate forward (→ 26, 30).

6. Remove all cables that connect the control module to the CA80 (cable harness for the electronics compartment).
7. Remove the carrier plate.
8. Use a desk or a worktop as a work surface. Place the carrier plate together with the carrier plate cover on this work surface.
9. Remove the light barrier from the linear drives. To do so, undo the screws (Torx T20, →  27,  31).
10. Remove the ribbon cable from the light barriers module (not required if only one linear drive is replaced).

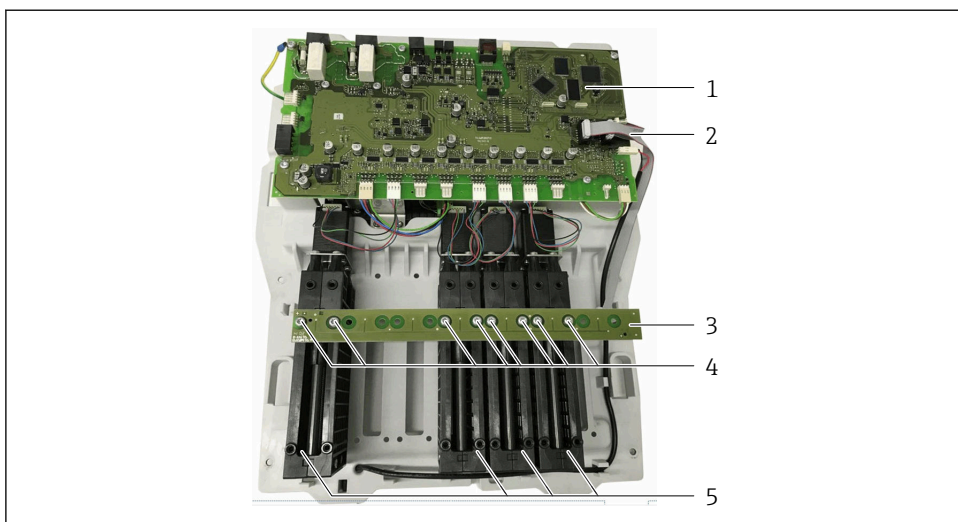



A0057734



 27 Overview of light barriers and linear drives

- 1 Control module (cover removed)
- 2 Ribbon cable for light barrier
- 3 Light barrier (in the figure: Type V1)
- 4 Torx T20 mounting screws
- 5 Linear drives

### 6.5.3 Replacing light barrier module version V2 or a linear drive

- Carry out the preparatory work according to Section 6.5.2 →  30.

**Replace the light barrier (→  28,  32):**

1. Use spare parts kit 71465074.
2. Replace the light barrier. Insert the ribbon cable into the new light barrier (→  26,  30). Turn the light barrier and then secure it.

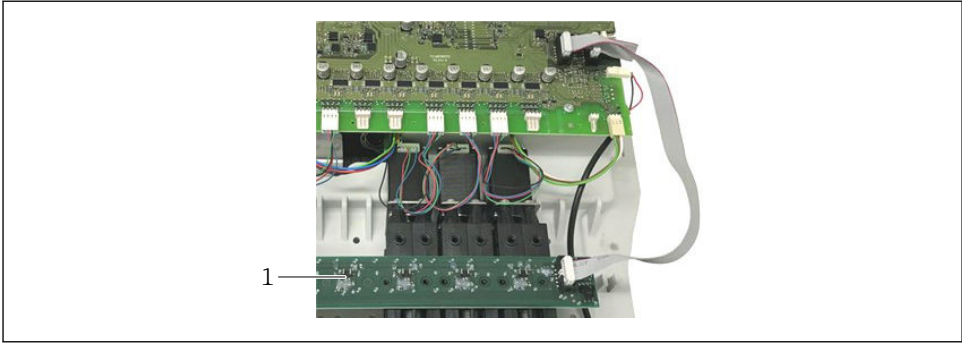

A0057735

### 28 Connecting the ribbon cable

#### 1 Light barrier (version V2)

**i** The next work step can be skipped for CA80SI/82HA. This additional cable is not required for CA80SI/82HA.

3. Plug the cable into the Liquid Manager at the top of the new light barrier  
(→ 29, 32).

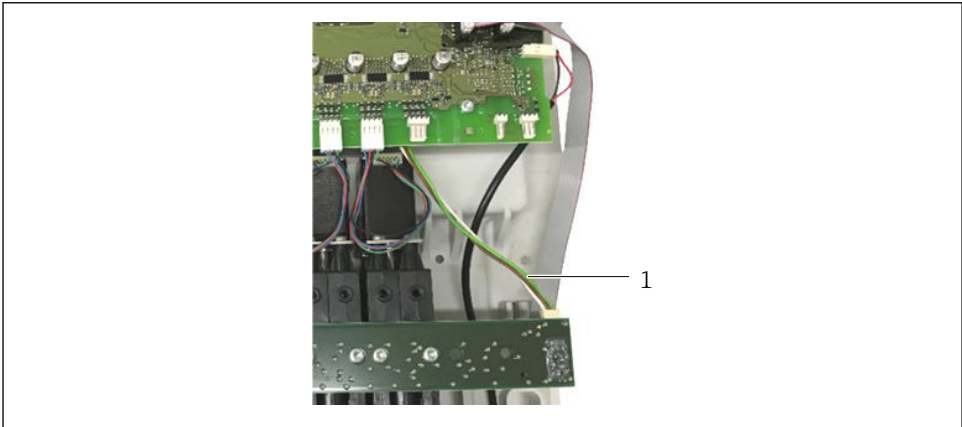

A0057736

### 29 Light barrier connector at top

#### 1 Cable to the Liquid Manager, connection to light barrier V2

4. Insert the additional cable (1) from the service kit in the control module at plug connector LM (2) and insert the bottom of the light barrier (3) → 30, 33.



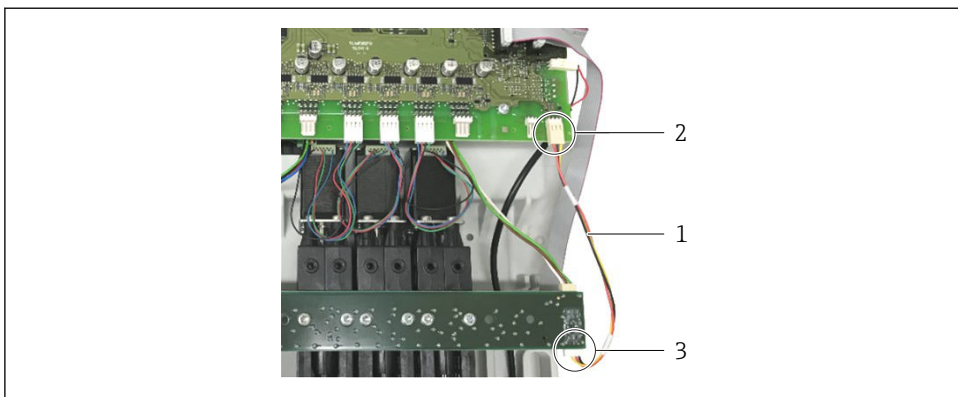

A0057738

▣ 30 Light barrier connector, bottom

- 1 Light barrier cable ↔ control module
- 2 LM connector, see also Figure 28
- 3 Light barrier

### Replacing a linear drive (→ ▣ 27, 📄 31):

1. Use spare parts kit 71218490.
2. Disconnect the connector of the defective linear drive from the control module (for plug connectors, see also → ▣ 36, 📄 39 to → ▣ 39, 📄 42).
3. Undo the screws of the defective linear drive (4 Torx T20 screws).
4. Install the new linear drive and connect the electrical connection.
5. Mount the light barrier again and connect the electrical connection.

### Assembling and testing the linear drive:

1. Reinstall the carrier plate.

#### **⚠ CAUTION**

**Pay attention to the leakage detector and the two temperature sensors of the cooling module at the bottom of the carrier plate!**

- ▶ The components and cables must not be pinched or crushed.

### Check whether the new drive is working:

2. Open the **Menu → Operation → Maintenance → Dispenser replacement → Dispenser selection**.
3. Select the dispenser to be tested.
4. Confirm the selection by pressing **OK**.
5. Select **Draw up dispenser** to move the dispenser to the lower position.
6. Check whether the dispenser is moving.

7. Check that the dispenser reaches the lower position.

#### 6.5.4 Replacing light barriers module V1

1. Use spare parts kit 71218491.
2. Carry out the preparatory work according to Section 6.5.2 →  30.

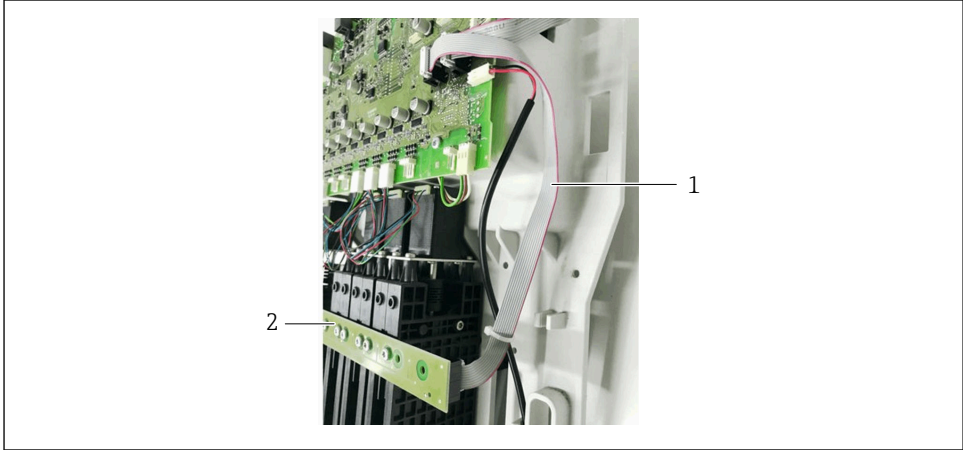

A0057739

#### 31 Connecting the ribbon cable

- 1 Ribbon cable for light barrier
- 2 Light barrier version V1

3. Replace the light barrier.
4. Mount the new light barrier and connect the electrical connection.
5. Reinstall the carrier plate.

#### CAUTION

**Pay attention to the leakage detector and the two temperature sensors of the cooling module at the bottom of the carrier plate!**

- ▶ The components and cables must not be pinched or crushed.

### 6.5.5 Modifying from light barriers module version V1 to the new V2 version

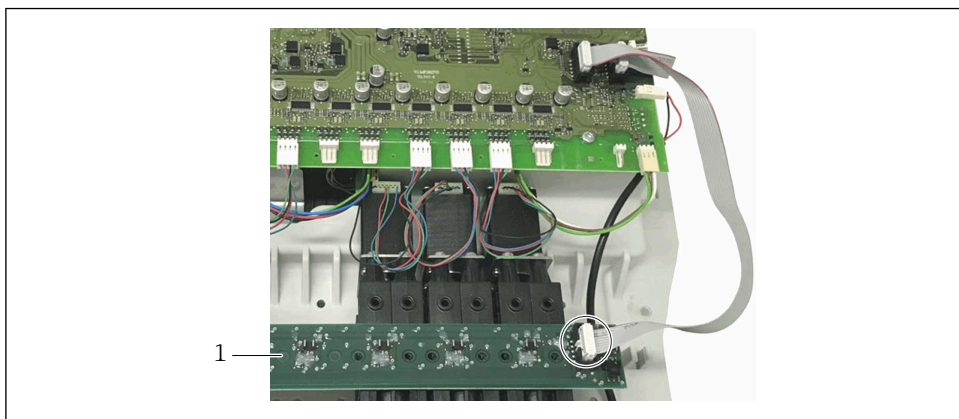

1. Use spare parts kit 71465074.
2. Carry out the preparatory work according to Section 6.5.2 →  30.





A0057740

#### 32 Connecting the ribbon cable

##### 1 Light barrier (type V2)

3. Replace the light barrier with the V2 type.
4. Insert the ribbon cable into the new light barrier (→  32,  35).
5. Turn the light barrier and secure it with the Torx T20 screws.

 The next work step can be skipped for CA80SI and CA82HA. This additional cable is not required for CA80SI and CA82HA.

6. Disconnect the cable to the Liquid Manager from the control module (connector LM (2)) and insert it at the top of the new light barrier (3) →  33,  36.

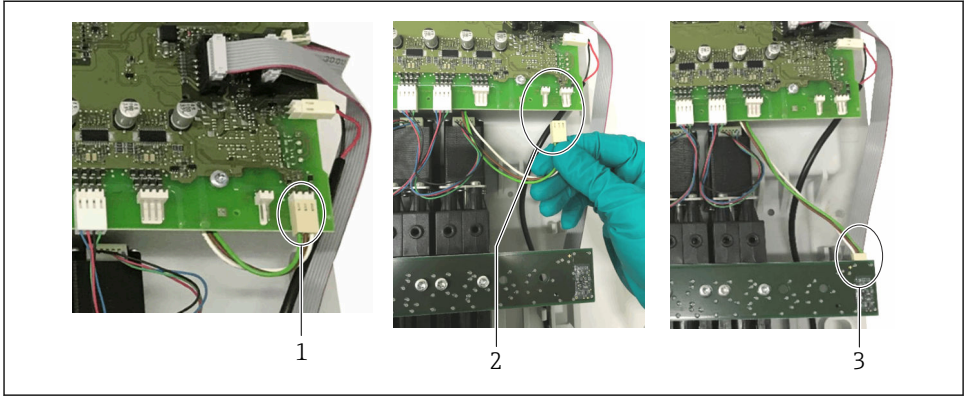

A0057741

33 Light barrier connector at top

1 "LM light barrier" connector

- 7. Insert the additional cable from the service kit at the control module in connector LM (1) and insert it below at the light barrier (2) → 34, 36.

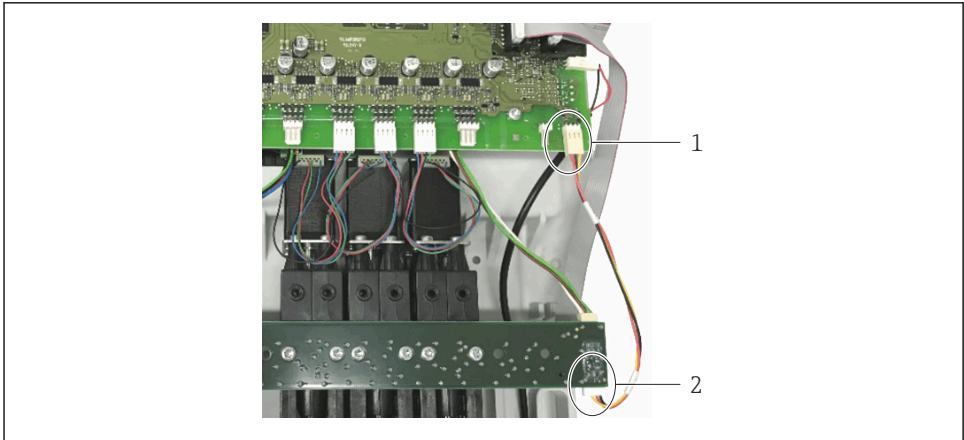

A0057742

34 Light barrier connector, bottom

1 "LM light barrier" connector











- 8. Reinstall the carrier plate.

**⚠ CAUTION**

**Pay attention to the leakage detector and the two temperature sensors of the cooling module at the bottom of the carrier plate!**

- ▶ The components and cables must not be pinched or crushed.

## 6.6 Replacing the control module

1. Only replace control module version 1 with version 1, or version 2 with version 2 (see also Section 4.1 ).
2. Perform the preparatory work as described in Section 6.1.2 →  25 and remove the bottle tray.
3. Disconnect the sample preparation (hoses and cables) from CA8x.
4. Disconnect all the hoses from the Liquid Manager.
5. Remove the screws of the carrier plate (6 Allen screws, 3 mm).
6. Fold out the carrier plate (→  26,  30).
7. Disconnect all the cables that connect the control module to the electronics compartment (→  35,  38).
8. Remove the entire carrier plate.
9. Place the carrier plate on a suitable working surface (table or worktop).
10. Disconnect the remaining connectors from the control module (→  36,  39).
11. Undo the mounting screws of the control module (7 Torx T20 screws) and replace the module.
12. Plug in the connectors again (→  35,  38 to →  39,  42).
13. Reinstall the carrier plate.

**⚠ CAUTION**

**Pay attention to the leakage detector and the two temperature sensors of the cooling module at the bottom of the carrier plate!**

- ▶ The components and cables must not be pinched or crushed.

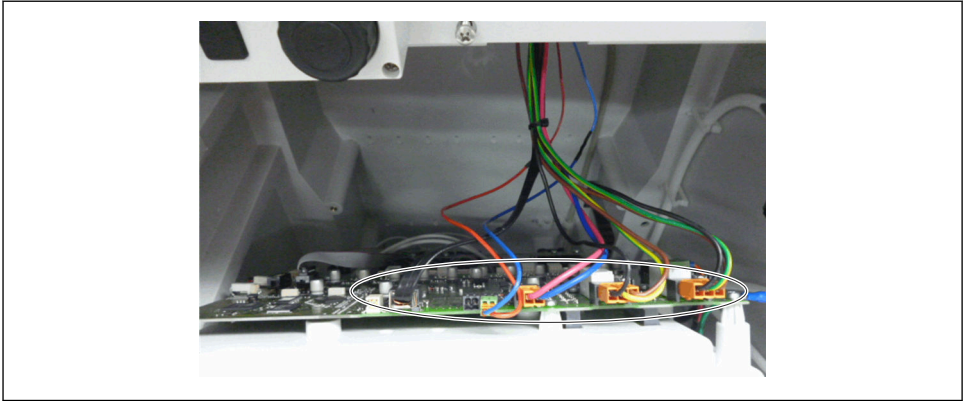

A0057743

35 *Connections for the control module to the electronics compartment*

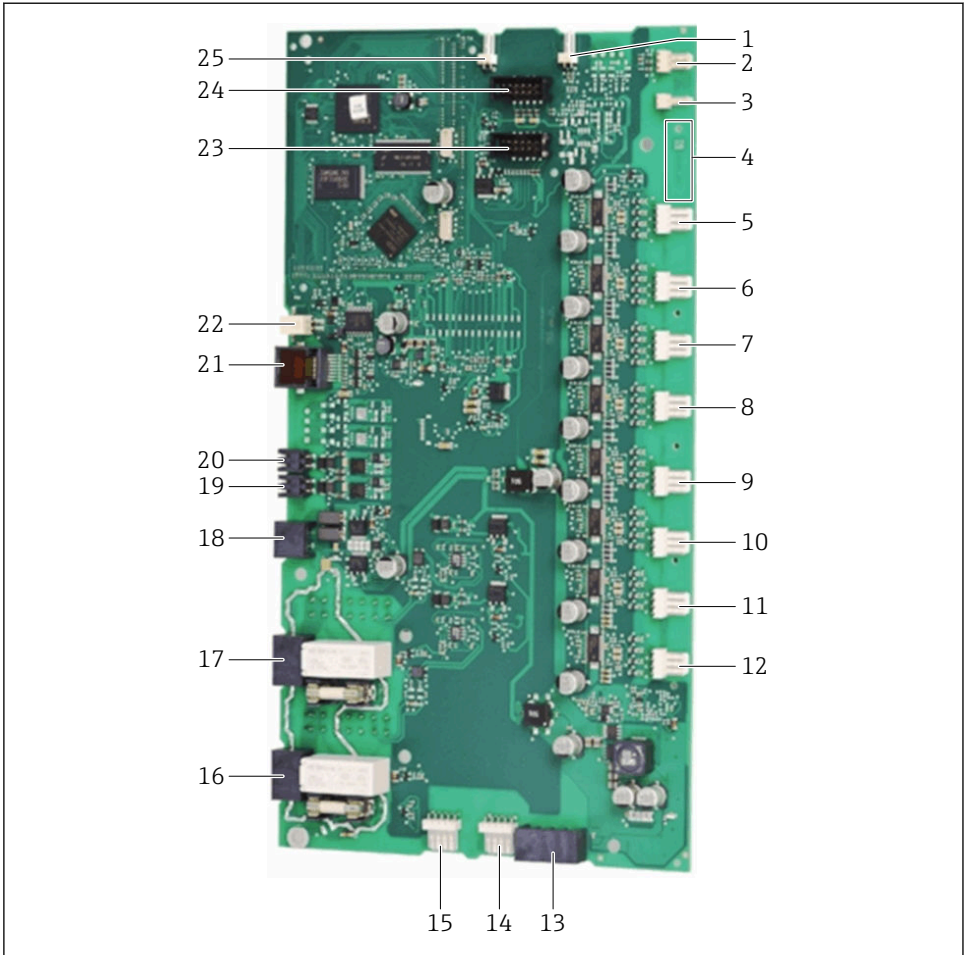

A0057744

36 Connection overview for V1 control module (FXAB1)

- 1 Leak detector
- 2 LM light barrier
- 3 Pt1000 cooling module, hot
- 4 Identification/module name
- 5 Stepping motor 1 (dispenser drive)
- 6 Stepping motor 2 (dispenser drive)
- 7 Stepping motor 3 (dispenser drive)
- 8 Stepping motor 4 (dispenser drive)
- 9 Stepping motor 5 (dispenser drive)
- 10 Stepping motor 6 (dispenser drive)
- 11 Stepping motor 7 (dispenser drive)
- 12 Stepping motor 8 (Liquid Manager motor)
- 13 Peltier element

- 14 Sample 1 level
- 15 Sample 2 level
- 16 Hose heating PVB1
- 17 Hose heating PVB2
- 18 24 V power supply input
- 19 Sample collector valve
- 20 Housing fan
- 21 CM44 communication
- 22 CDI
- 23 Light barrier for linear drives
- 24 Photometer
- 25 Pt1000 cooling mode, cold

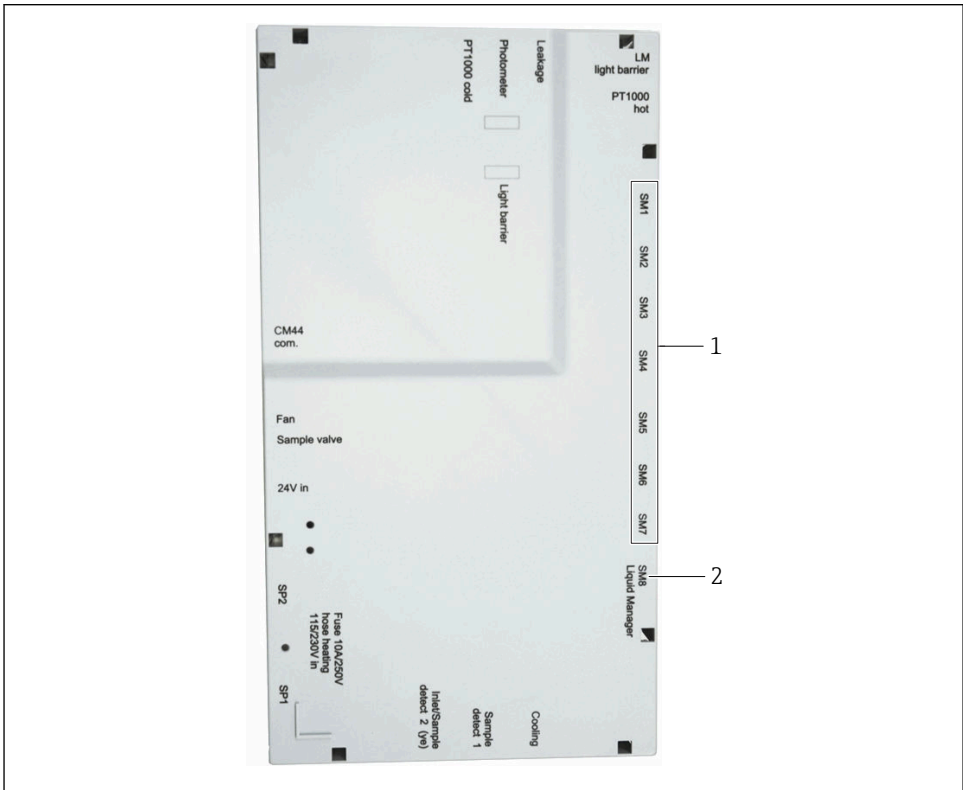

A0057745

37 Cover of control module V1 (FXAB1) with labeling

- 1 SM1 to SM7 = linear drives for dispensers (SM = stepping motor)
- 2 SM8 = Liquid Manager motor



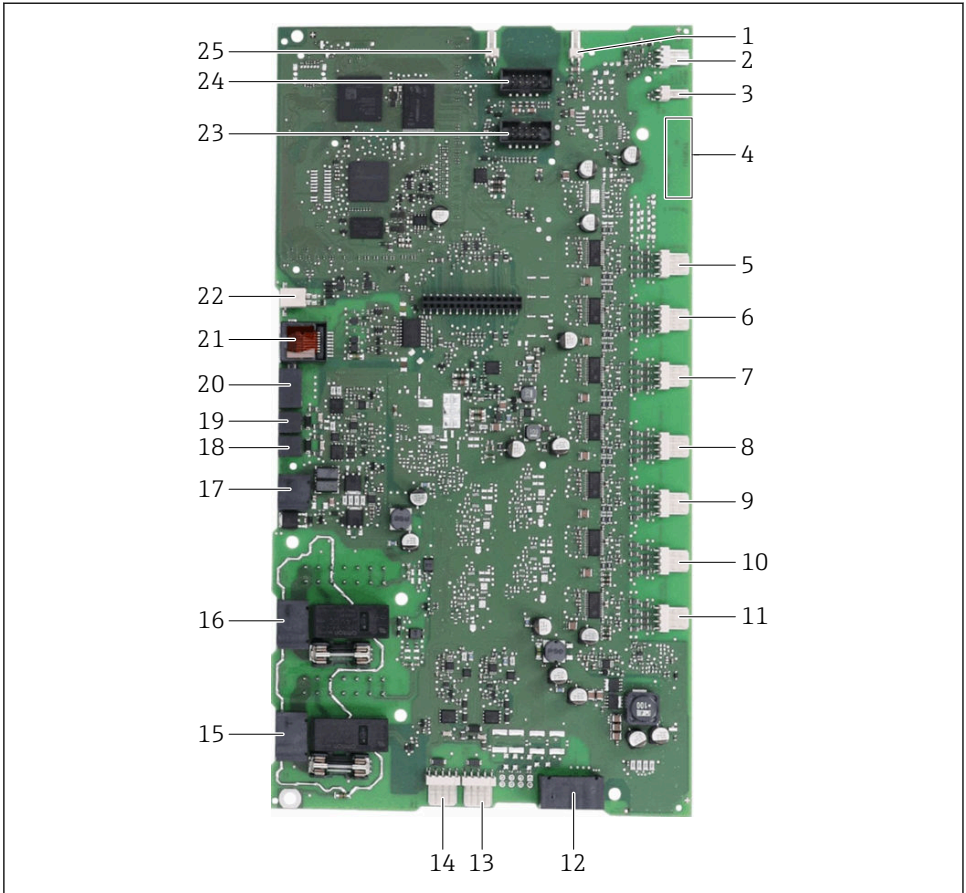

A0057746

38 Connection overview for V2 control module (FXAB2)

- 1 Leak detector
- 2 Light barrier for Liquid Manager
- 3 Pt1000 cooling module, hot
- 4 Identification/module name
- 5 Stepping motor 2 (dispenser drive)
- 6 Stepping motor 3 (dispenser drive)
- 7 Stepping motor 4 (dispenser drive)
- 8 Stepping motor 5 (dispenser drive)
- 9 Stepping motor 6 (dispenser drive)
- 10 Stepping motor 7 (dispenser drive)
- 11 Stepping motor 8 (Liquid Manager motor)
- 12 Peltier element
- 13 Sample 1 level
- 14 Sample 2 level
- 15 Hose heating PVB1

- 16 Hose heating PVB2
- 17 24 V power supply input
- 18 Sample collector valve
- 19 Housing fan
- 20 Only for CA80AM-*\*S1/S2/S3*
- 21 CM44 communication
- 22 CDI
- 23 Light barrier for linear drives
- 24 Photometer
- 25 Pt1000 cooling mode, cold

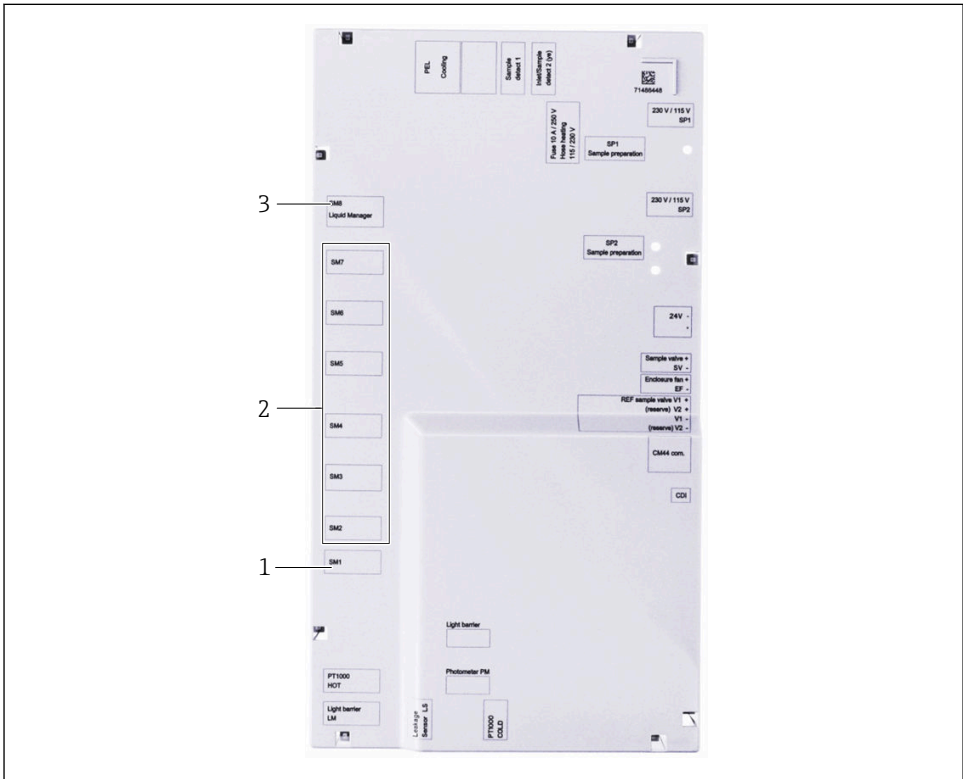

A0057747

**39** Cover of control module V2 (FXAB2) with labeling

- 1 SM1 = not used (SM = stepping motor)
- 2 SM2 to SM7 = linear drives for dispensers
- 3 SM8 = Liquid Manager motor

## 6.7 Final steps

### 6.7.1 Final steps after work without removing the chemical containers according to Section 6.1.1.

1. Re-establish the power supply.
2. Select **Mode** → **Continue automatic mode**.

### 6.7.2 Final steps after work with the removal of the chemical containers according to Section 6.1.2 or 6.1.3

1. Insert the bottle tray with reagents, standard and cleaner.
2. Reconnect all the hoses.
3. Switch the power supply to the analyzer back on.
4. Connect hoses to the reagent containers and fill the hoses as described below:
5. Select **Menu** → **Operation** → **Maintenance** → **Bottle replacement** → **Bottle insertion** → **Bottle selection**.
6. Highlight all the bottles and confirm by pressing the **OK** softkey.
7. Select **Bottles inserted confirmation**.
8. Activate the sample feed (depending on the type of sample preparation).
9. Select **Mode** → **Continue automatic mode** to start the normal measuring operation of the CA8x.

## 7 Additional documentation

Detailed information on the devices can be found in the Operating Instructions for the analyzer and in the other documentation, available at:

- [www.endress.com/device-viewer](http://www.endress.com/device-viewer)
- Smartphone/tablet: Endress+Hauser Operations app

## 8 Disposal



If required by the Directive 2012/19/EU on waste electrical and electronic equipment (WEEE), the product is marked with the depicted symbol in order to minimize the disposal of WEEE as unsorted municipal waste. Do not dispose of products bearing this marking as unsorted municipal waste. Instead, return them to the manufacturer for disposal under the applicable conditions.



71719638

[www.addresses.endress.com](http://www.addresses.endress.com)

---