

Brief Operating Instructions

Liquiline CM42B

Two-wire transmitter

Device for DIN rail mounting

Measurement with digital Memosens sensors





Table of contents









1	About this document	3
1.1	Safety information	3
1.2	Symbols	3
1.3	Symbols on the device	3
1.4	Documentation	4
2	Basic safety instructions	5
2.1	Requirements for the personnel	5
2.2	Intended use	5
2.3	Workplace safety	5
2.4	Operational safety	6
2.5	Product safety	6
2.6	IT security	6
3	Product description	7
3.1	Product design	7
4	Incoming acceptance and product identification	9
4.1	Incoming acceptance	9
4.2	Product identification	9
4.3	Scope of delivery	10
5	Installation	11
5.1	Installation requirements	11
5.2	Installing the device	12
5.3	Post-installation check	22
6	Electrical connection	23
6.1	Connecting requirements	23
6.2	Connecting the device	24
6.3	Ensuring the degree of protection	31
6.4	Post-connection check	32
7	Operation options	32
7.1	Overview of operation options	32
7.2	Access to the operating menu via the local display	32
7.3	Access to the operating menu via the operating tool	39
8	System integration	42
8.1	Integrating the measuring instrument into the system	42
9	Commissioning	44
9.1	Preliminaries	44
9.2	Function check	44
9.3	Time and date	45
9.4	Configuring the operating language	45
9.5	Transferring device parameters to other devices	45
	Index	46

1 About this document

1.1 Safety information

Structure of information	Meaning
<p> DANGER</p> <p>Causes (/consequences) If necessary, Consequences of non-compliance (if applicable)</p> <ul style="list-style-type: none"> ▶ Corrective action 	<p>This symbol alerts you to a dangerous situation. Failure to avoid the dangerous situation will result in a fatal or serious injury.</p>
<p> WARNING</p> <p>Causes (/consequences) If necessary, Consequences of non-compliance (if applicable)</p> <ul style="list-style-type: none"> ▶ Corrective action 	<p>This symbol alerts you to a dangerous situation. Failure to avoid the dangerous situation can result in a fatal or serious injury.</p>
<p> CAUTION</p> <p>Causes (/consequences) If necessary, Consequences of non-compliance (if applicable)</p> <ul style="list-style-type: none"> ▶ Corrective action 	<p>This symbol alerts you to a dangerous situation. Failure to avoid this situation can result in minor or more serious injuries.</p>
<p>NOTICE</p> <p>Cause/situation If necessary, Consequences of non-compliance (if applicable)</p> <ul style="list-style-type: none"> ▶ Action/note 	<p>This symbol alerts you to situations which may result in damage to property.</p>

1.2 Symbols

	Additional information, tips
	Permitted
	Recommended
	Not permitted or not recommended
	Reference to device documentation
	Reference to page
	Reference to graphic
	Result of an individual step

1.3 Symbols on the device

	Reference to device documentation
	Do not dispose of products bearing this marking as unsorted municipal waste. Instead, return them to the manufacturer for disposal under the applicable conditions.

1.4 Documentation

In addition to these Brief Operating Instructions , the following manuals are available on the product pages on our website:

Operating Instructions, BA02381C

- Device description
- Commissioning
- Operation
- Device-specific diagnostics and troubleshooting
- Maintenance
- Repair and spare parts
- Accessories
- Technical data

2 Basic safety instructions

2.1 Requirements for the personnel

- Installation, commissioning, operation and maintenance of the measuring system may be carried out only by specially trained technical personnel.
- The technical personnel must be authorized by the plant operator to carry out the specified activities.
- The electrical connection may be performed only by an electrical technician.
- The technical personnel must have read and understood these Operating Instructions and must follow the instructions contained therein.
- Faults at the measuring point may only be rectified by authorized and specially trained personnel.



Repairs not described in the Operating Instructions provided must be carried out only directly at the manufacturer's site or by the service organization.

2.2 Intended use

2.2.1 Areas of application

The device is a two-wire transmitter for connecting digital sensors with Memosens technology (configurable). It features a 4 to 20 mA current output with optional HART communication and can be operated via an onsite display or optionally using a smartphone or other mobile devices via Bluetooth.

The device is designed for use in the following industries:

- Chemical industry
- Pharmaceutical industry
- Water and wastewater
- Food and beverage production
- Power stations
- Applications in hazardous areas
- Other industrial applications

2.2.2 Non-designated use

Any use other than that intended puts the safety of people and the measuring system at risk. Therefore, any other use is not permitted.

The manufacturer is not liable for harm caused by improper or unintended use.

2.3 Workplace safety

The operator is responsible for ensuring compliance with the following safety regulations:

- Installation guidelines
- Local standards and regulations
- Regulations for explosion protection

Electromagnetic compatibility

- The product has been tested for electromagnetic compatibility in accordance with the applicable international standards for industrial applications.
- The electromagnetic compatibility indicated applies only to a product that has been connected in accordance with these Operating Instructions.

2.4 Operational safety

Before commissioning the entire measuring point:

1. Verify that all connections are correct.
2. Ensure that electrical cables and hose connections are undamaged.

Procedure for damaged products:

1. Do not operate damaged products, and protect them against unintentional operation.
2. Label damaged products as defective.

During operation:

- ▶ If errors cannot be rectified, take products out of service and protect them against unintentional operation.

2.5 Product safety

The product is designed to meet state-of-the-art safety requirements, has been tested, and left the factory in a condition in which it is safe to operate. The relevant regulations and international standards have been observed.

2.6 IT security

We only provide a warranty if the device is installed and used as described in the Operating Instructions and the Security Manual. The device is equipped with security mechanisms to protect it against any inadvertent changes to the device settings.

IT security measures in line with operators' security standards and designed to provide additional protection for the device and device data transfer must be implemented by the operators themselves. For more information, see the Security Manual.

3 Product description

3.1 Product design

3.1.1 Device

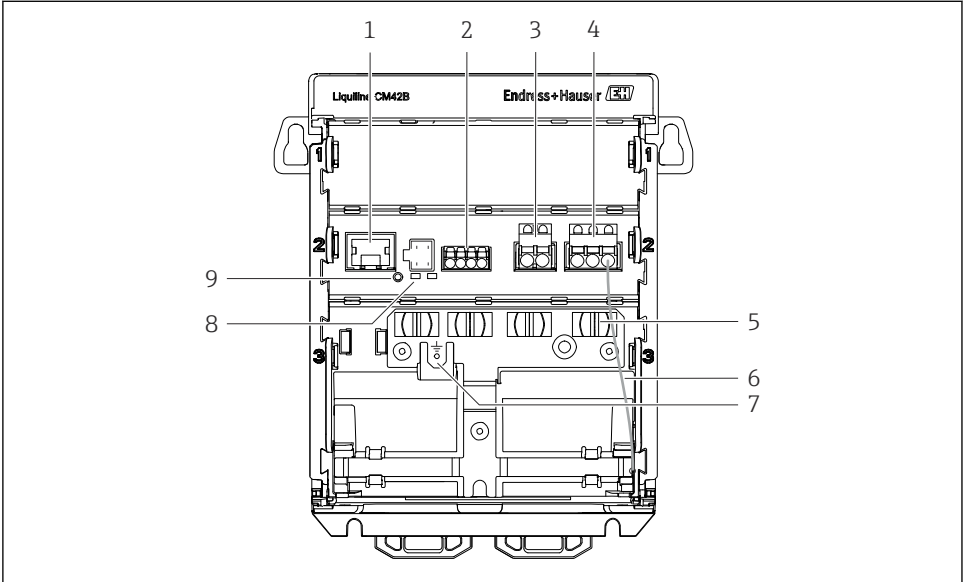

A0054759

- 1 RJ45 socket for display cable
- 2 Memosens input
- 3 Current output 1: 4 to 20 mA/optional HART, passive
- 4 Current output 2 (optional): 4 to 20 mA, passive
- 5 Cable mounting rail
- 6 Internal ground cable (wired at the factory)
- 7 Connection for potential equalization or functional earth, connection established via cable lug 6.35 mm
- 8 Status LEDs
- 9 Reset button



The status LEDs are only active if no external display is connected.

3.1.2 External display (optional)

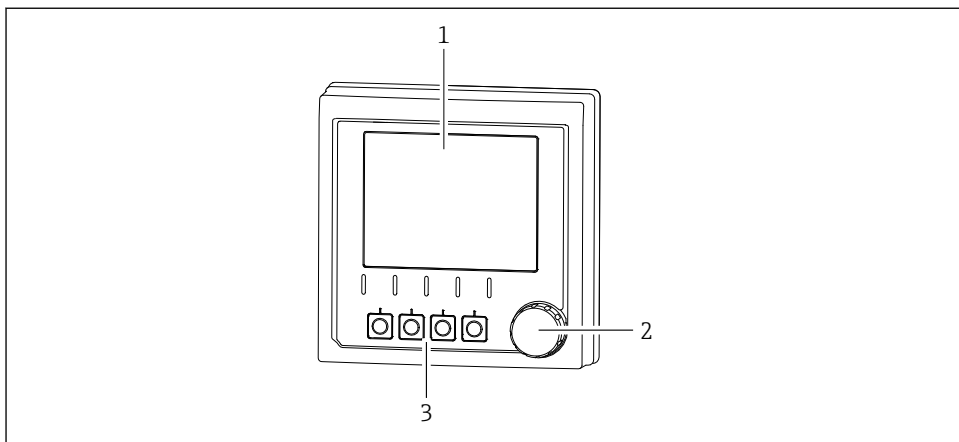

A0054836

1 External display (optional)

- 1 Display
- 2 Navigator
- 3 Soft keys, assignment depends on menu

3.1.3 Measuring parameters

The transmitter is designed for digital Memosens sensors.

The following measuring parameters are:

- pH/ORP
- Conductivity, measured conductively
- Conductivity, measured inductively
- Dissolved oxygen, measured amperometrically
- Dissolved oxygen, measured optically

The measuring parameters and sensor type can be switched via the user interface.

For a list of compatible sensors, see the Operating Instructions, "Accessories" section.

4 Incoming acceptance and product identification

4.1 Incoming acceptance

1. Verify that the packaging is undamaged.
 - ↳ Notify the supplier of any damage to the packaging.
Keep the damaged packaging until the issue has been resolved.
2. Verify that the contents are undamaged.
 - ↳ Notify the supplier of any damage to the delivery contents.
Keep the damaged goods until the issue has been resolved.
3. Check that the delivery is complete and nothing is missing.
 - ↳ Compare the shipping documents with your order.
4. Pack the product for storage and transportation in such a way that it is protected against impact and moisture.
 - ↳ The original packaging offers the best protection.
Make sure to comply with the permitted ambient conditions.

If you have any questions, please contact your supplier or your local Sales Center.

4.2 Product identification

4.2.1 Nameplate

The following information on the device can be found on the nameplate:

- Manufacturer identification
 - Product designation
 - Serial number
 - Ambient conditions
 - Input and output values
 - Safety information and warnings
 - Ex markings
 - Certification information
 - Warnings
- ▶ Compare the information on the nameplate with the order.

4.2.2 Identifying the product

Manufacturer address

Endress+Hauser Conducta GmbH+Co. KG
Dieselstraße 24
70839 Gerlingen
Germany

Product page

www.endress.com/CM42B

Interpreting the order code

The order code and serial number of your product can be found in the following locations:

- In the delivery papers
- On the internal label
- Serial number: on the nameplate
- Order code via the device menu: **Menu/System/Information/Device**

Obtaining information on the product

1. Scan the QR code on the product.
2. Open the URL in a web browser.
3. Click the product overview.
 - ↳ A new window opens. Here you will find information pertaining to your device, including the product documentation.

Obtaining information on the product (if there is no option for scanning the QR code)

1. Go to www.endress.com.
2. Page search (magnifying glass symbol): Enter valid serial number.
3. Search (magnifying glass).
 - ↳ The product structure is displayed in a popup window.
4. Click the product overview.
 - ↳ A new window opens. Here you will find information pertaining to your device, including the product documentation.

4.3 Scope of delivery

The scope of delivery includes:

- Liquiline CM42B
- Brief Operating Instructions
- Safety instructions for hazardous area (for Ex versions)
- ▶ If you have any queries:
Please contact your supplier or local sales center.

5 Installation

5.1 Installation requirements

5.1.1 Dimensions

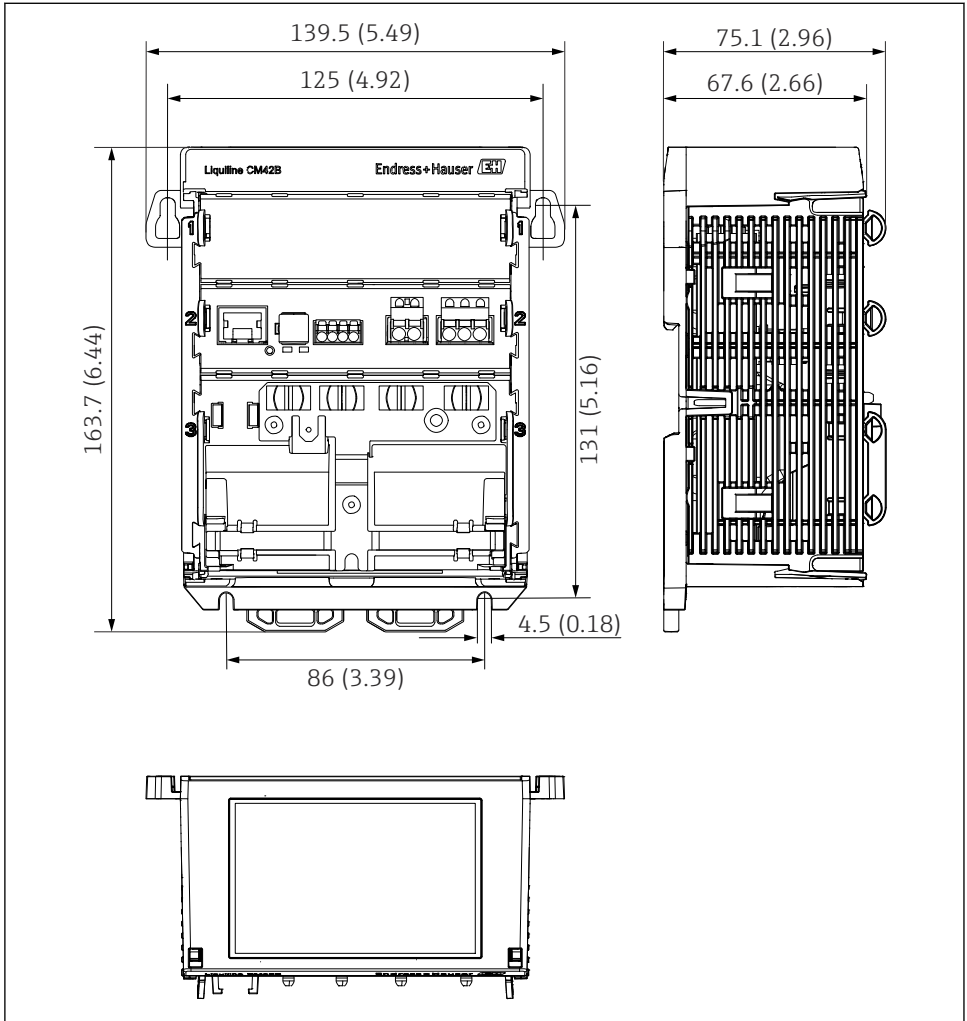

A0057647

2 Dimensions of device in mm (inches)

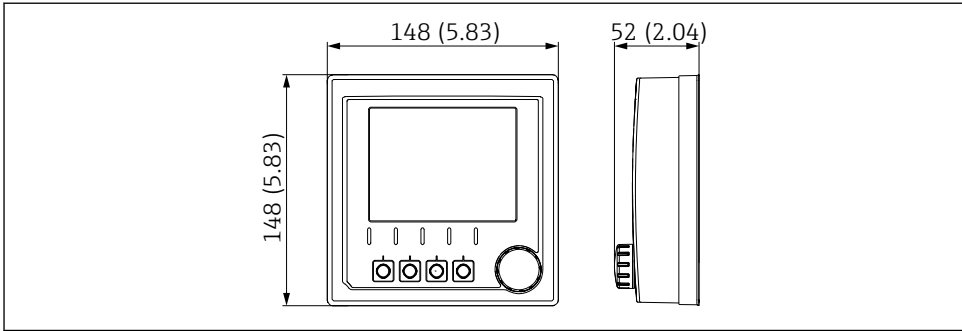

A0055931

3 Dimensions of external display in mm (inches)

5.1.2 Pollution degree

The device is designed for operation in a pollution degree 2 environment.

- ▶ Install the device in an appropriate housing.

5.2 Installing the device

5.2.1 Mounting on DIN rail as per IEC 60715

NOTICE

Condensation on the device

Potential device failure

- ▶ The device complies with the IP20 degree of protection. It is designed only for environments with non-condensing moisture.
- ▶ Comply with the specified ambient conditions, e.g. by installing the device in an appropriate protective enclosure.

NOTICE

Incorrect mounting location in the control cabinet, spacing regulations not observed

Possible malfunctions as a result of heat buildup and interference from neighboring devices!

- ▶ Do not position the device directly above sources of heat.
- ▶ The components are designed for convection-based cooling. Avoid heat buildup. Ensure openings are not covered, e.g. by cables.
- ▶ Observe the specified distances to other devices.
- ▶ Physically separate the device from frequency converters and high-voltage devices.

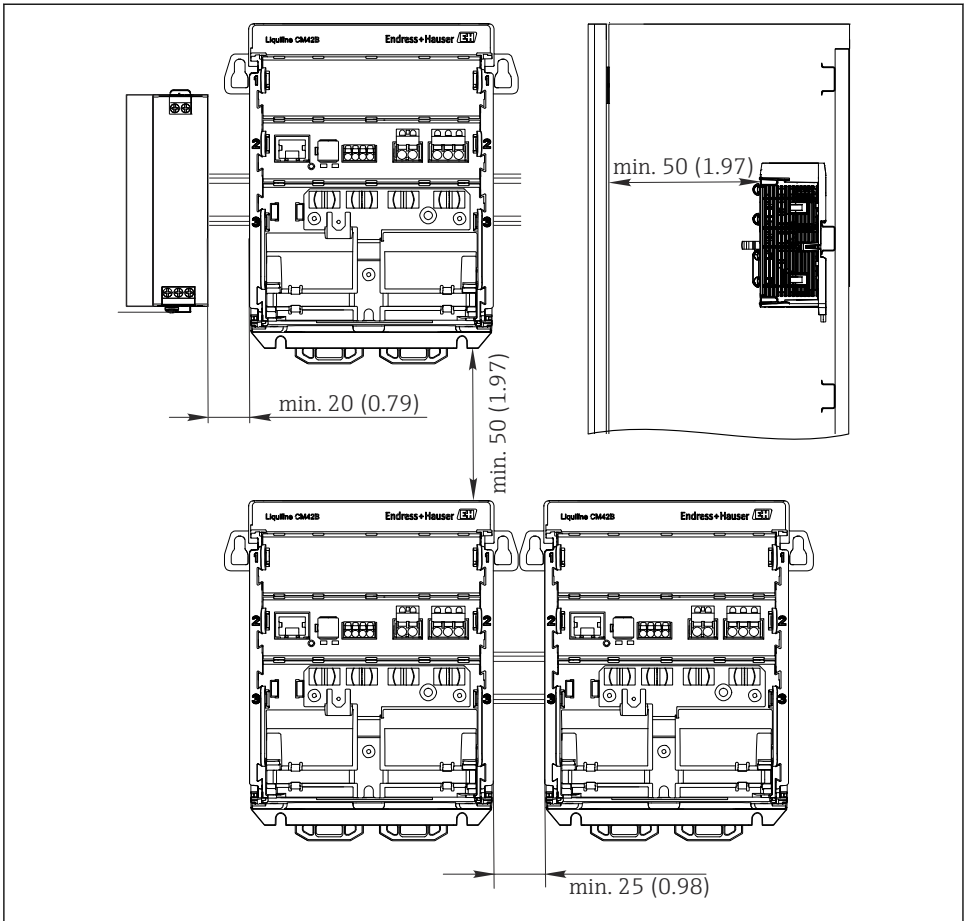

A0057277

4 Minimum clearance in mm (in)

Minimum clearances required:

- Distance at the side, to other devices and control cabinet wall:
at least 20 mm (0.79 inches)
- above and below the device and depth distance (to control cabinet door or other devices installed there):
at least 50 mm (1.97 inches)

1.

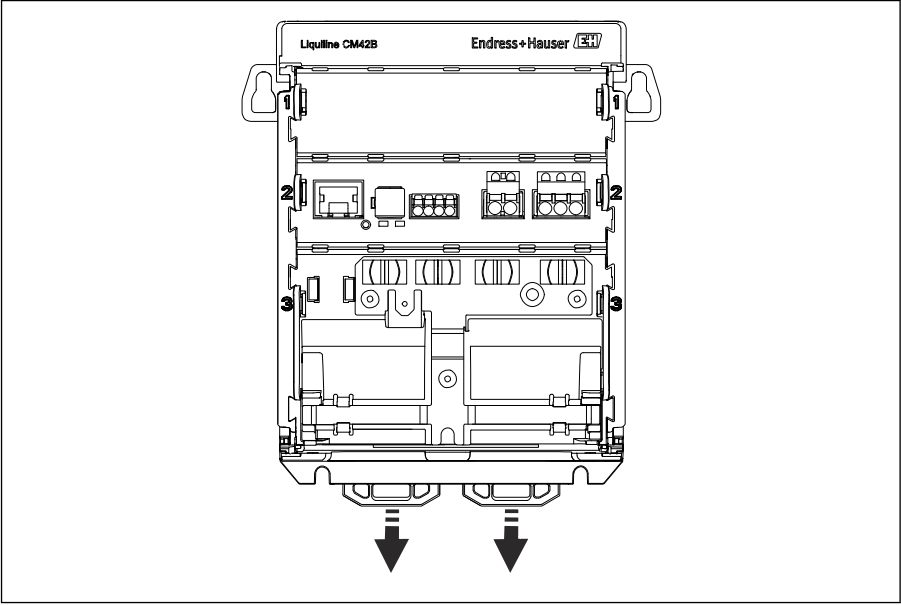

A0053951

When delivered, the securing clips are locked to secure the DIN rail.
Unlock the securing clips by pulling them downwards.

2.

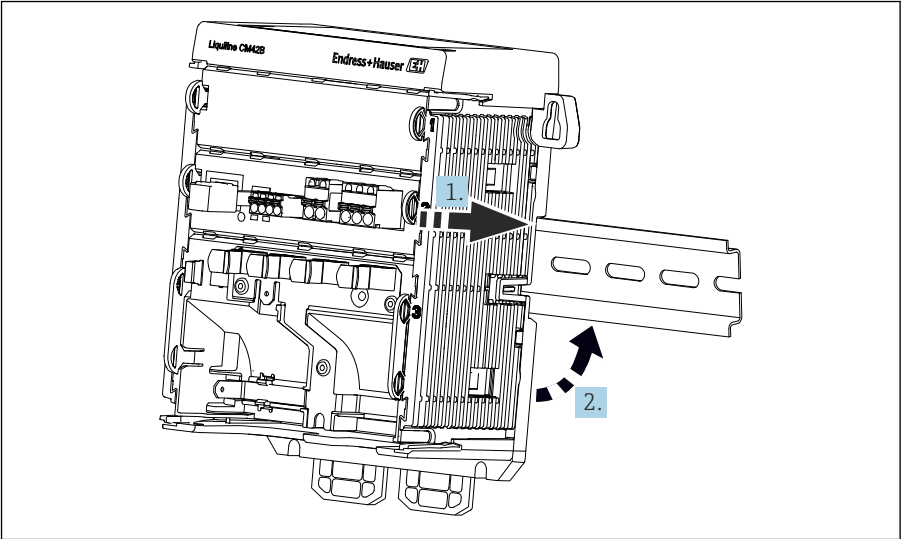

A0053961

Attach the device from the top to the DIN rail (1) and secure it by pressing down (2).

3.

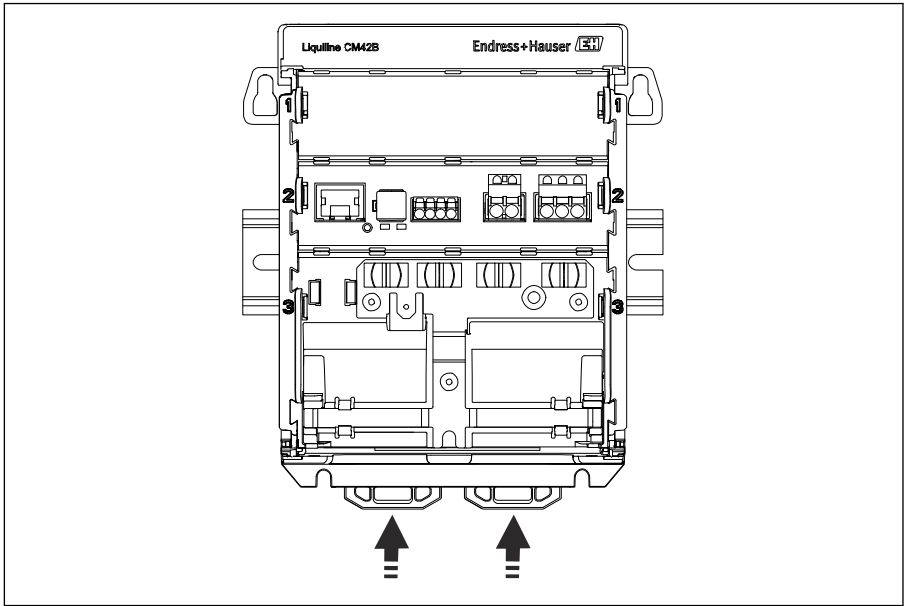

Slide the securing clips upwards until they click, thereby securing the device to the DIN rail.

5.2.2 Installing the external display (optional)



The mounting plate also serves as the drilling template. The side markings are used to mark the drill holes.

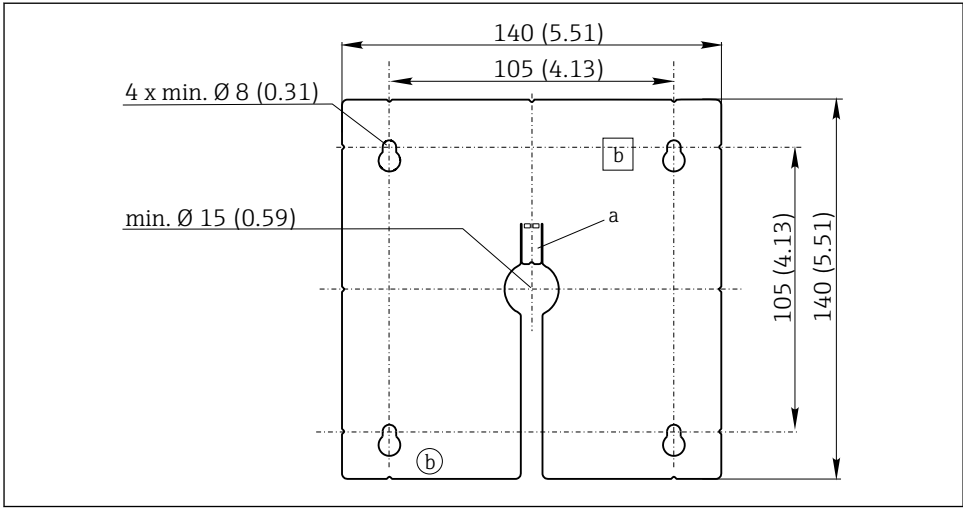

5 Mounting plate of external display, dimensions in mm (in)

a Retaining tab

b Production-related recesses, no function for the user

Mounting the external display on the control cabinet door

1.

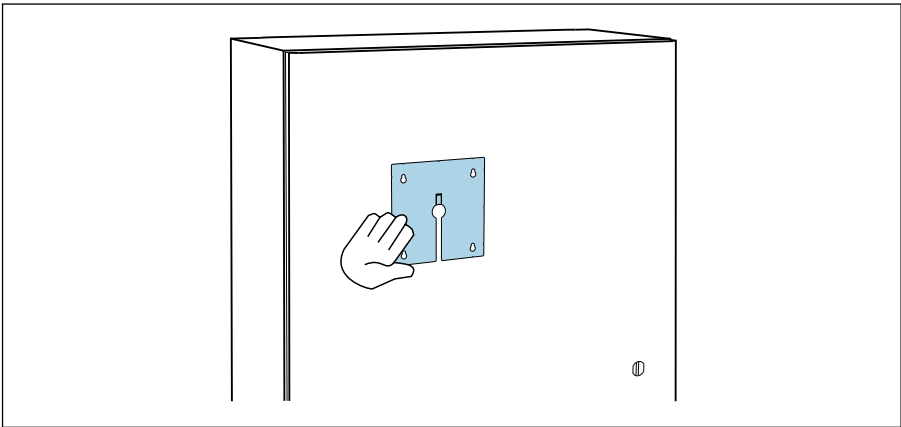

Hold the mounting plate from the outside against the door of the control cabinet. Select the position at which the external display is to be mounted.

2.

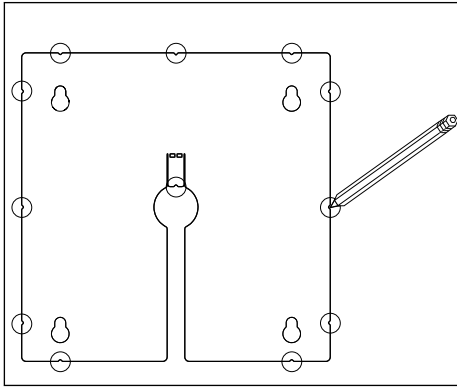

Make all the markings.

3.

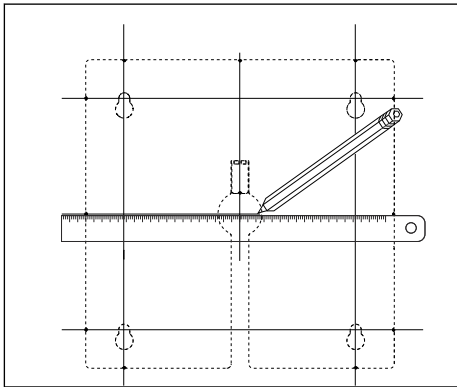



Draw lines to interconnect all the marks.

- ↳ The points of intersection of the lines mark the position of the 5 necessary boreholes.

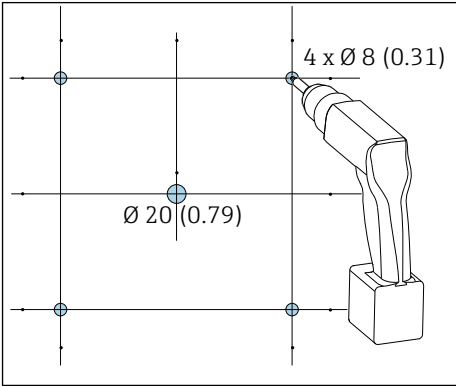
4.



 6 Diameter of boreholes in mm (in)

Drill the holes. →  5,  16

CAUTION

Sharp-edged, non-deburred boreholes

Risk of injury, display cable may get damaged!

- ▶ Trim and deburr all boreholes. In particular, make sure that the middle borehole for the display cable is properly deburred.

5.

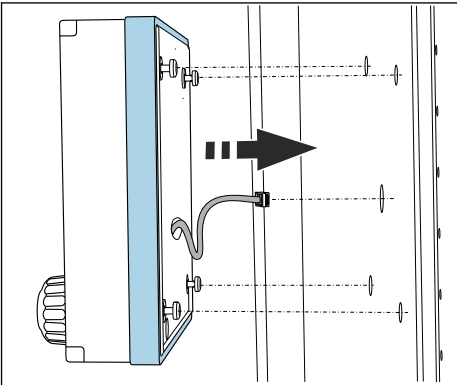

Pull the display cable through the central borehole.

6. Insert the external display with the screws unscrewed (but still in place) through the holes from the outside. Ensure that the rubber frame (seal, highlighted blue) does not become damaged and is properly positioned on the surface of the door.

7.

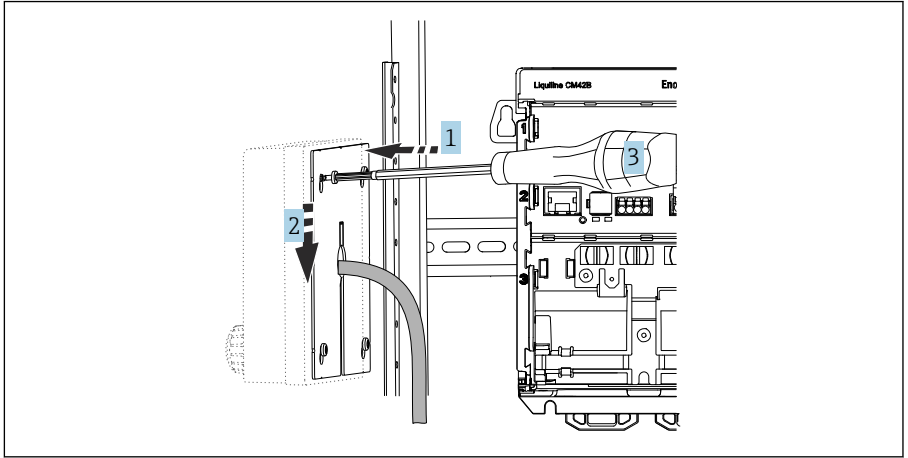

A0056921

Place the mounting plate on the inside over the screws (1), slide it down (2) and tighten the screws (3).

8.

NOTICE**Incorrect installation**

Damage and malfunctions possible.

- ▶ Lay cables in such a way that they do not get squashed e.g. when closing the cabinet door.

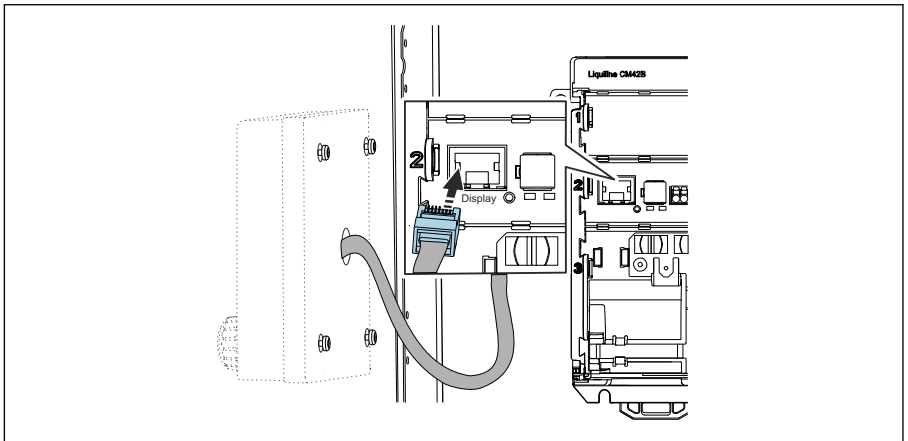

A0054843

Connect the display cable to the RJ50 socket of the transmitter. The RJ50 socket is labeled **Display**.

9.

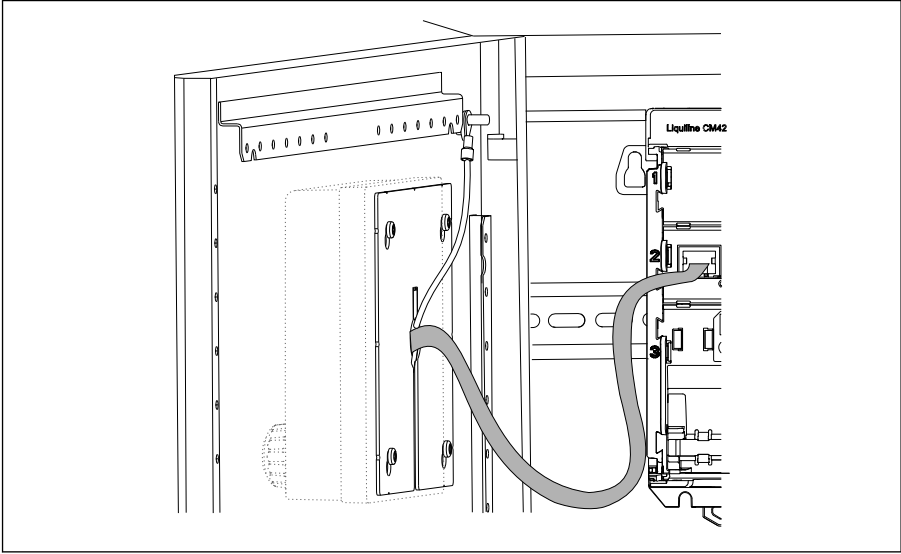

A0057640

Stainless steel display only: Connect the display's ground cable to the nearest grounding point.

↳ The external display is now mounted and ready to use.

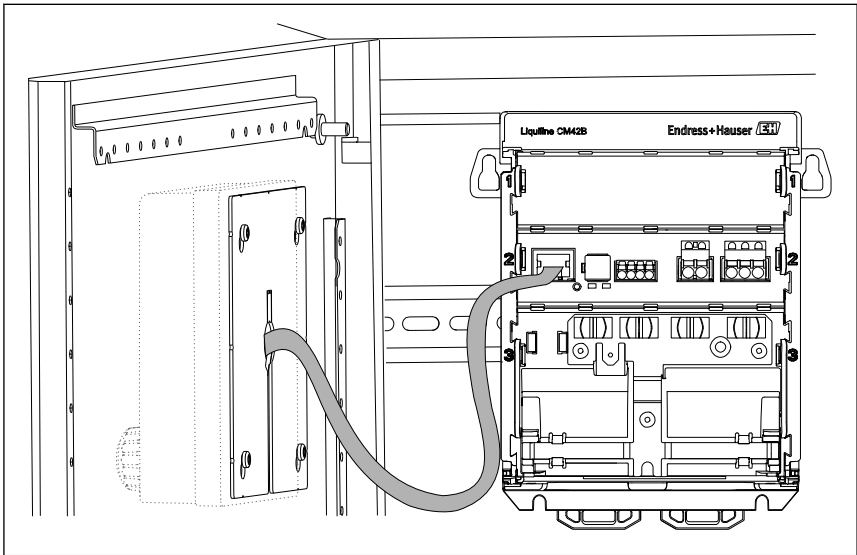

A0054845

7 External display mounted (plastic display without ground cable in illustration)

5.2.3 Mounting on panel (incl. external display)

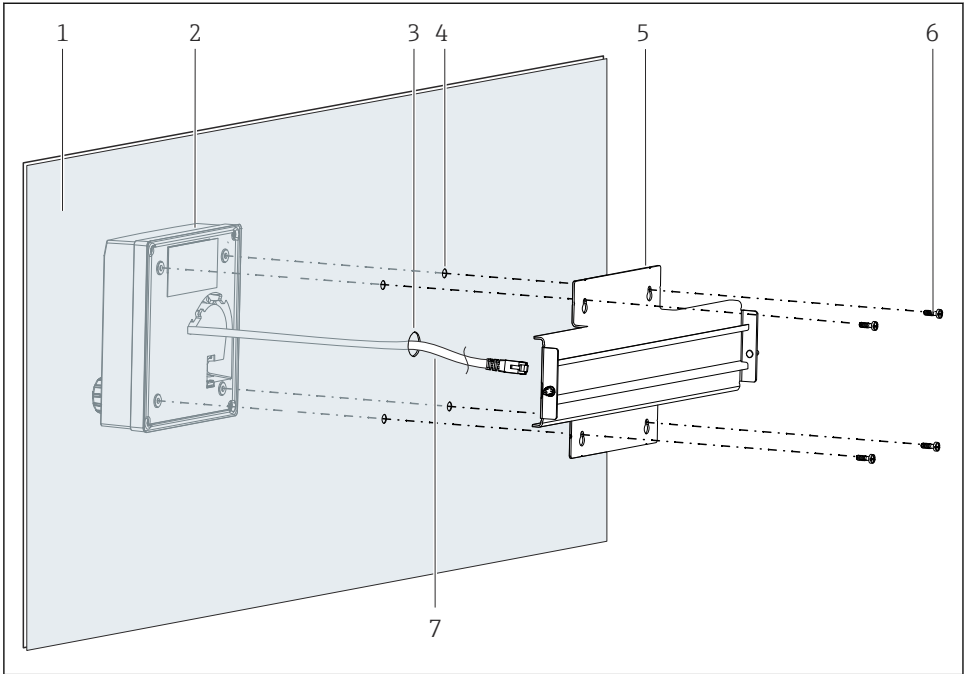

A0054860

8 Mounting the external display and DIN rail

- 1 Panel/mounting surface
- 2 External display
- 3 Drill hole for display cable
- 4 Drill holes for screws
- 5 Mounting plate with DIN rail
- 6 Screws
- 7 Display cable

1. Mount the external display on the panel as described in → 16. To do so, mount the DIN rail (5) on the back of the panel.

2.

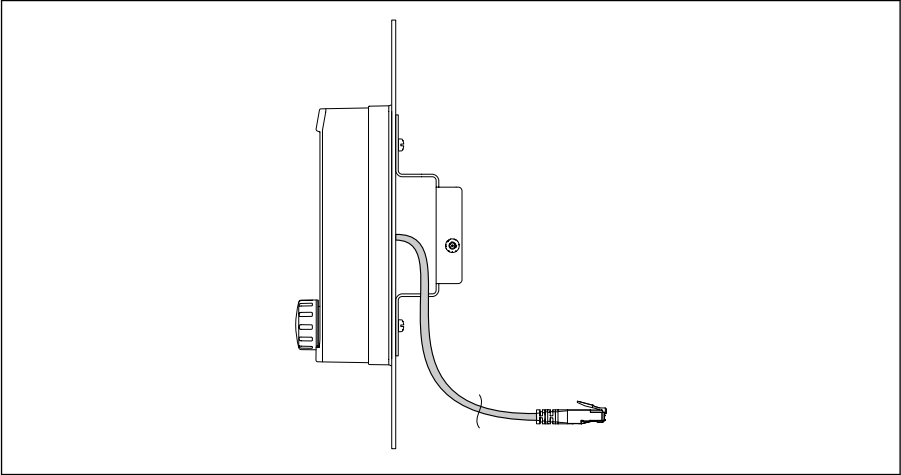

A0056254

9 *Layout of the display cable*

Route the display cable as shown in the illustration.

3.

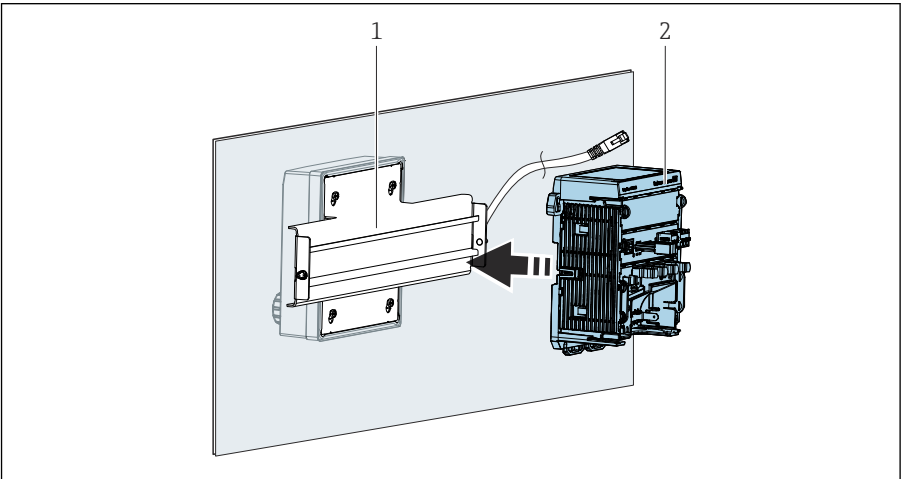

A0054861

- 1 *DIN rail*
- 2 *Transmitter*

Secure the transmitter (2) to the DIN rail (1) as described in → 12.

5.3 Post-installation check

1. Following mounting, check all devices (transmitter, external display) for damage.

2. Verify that all securing clips have been fully snapped into place and that the device is securely positioned on the DIN rail.
3. Verify that the specified installation clearances have been observed.
4. Ensure that the temperature limits are observed at the mounting location.

6 Electrical connection

6.1 Connecting requirements

6.1.1 Supply voltage

- ▶ Connect the device to a Safety Extra Low Voltage (SELV) or Protective Extra Low Voltage (PELV) system only.

6.1.2 Power units

- ▶ Use power units according to IEC 60558-2-16, IEC 62368-1 Class ES1 or IEC 61010-1.

6.1.3 Electrostatic discharge (ESD)

NOTICE

Electrostatic discharge (ESD)

Risk of damaging the electronic components

- ▶ Take personal protective measures to avoid ESD, such as discharging beforehand at PE or permanent grounding with a wrist strap, for example.

6.1.4 Unconnected cable cores

NOTICE

Unconnected cable cores can lead to malfunctions or damage to the device if they come into contact with connections, terminals and other conductive parts.

- ▶ Ensure that unconnected cable cores are sufficiently insulated from earth and from other cores by suitable terminations, e.g. by using heat-shrink tubing.

6.1.5 Installation in hazardous areas

Installation in hazardous area Ex ia Ga

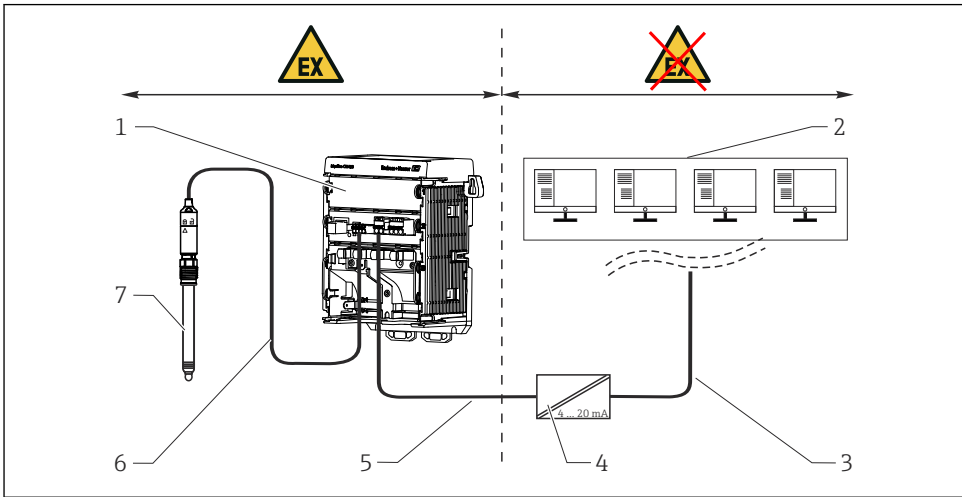

A0056648

- 1 Hazardous area version of Liquiline CM42B
- 2 Control station
- 3 4 to 20 mA signal line/optional HART
- 4 Ex ia active barrier
- 5 Supply and signal circuit Ex ia, 4 to 20 mA (HART optional)
- 6 Intrinsically safe sensor circuit Ex ia
- 7 Hazardous area version of sensor

6.2 Connecting the device

6.2.1 Connecting the cable shield

The descriptions of each of the connections specify which cables must be shielded.

i Only use terminated original cables where possible.

Clamping range of grounding clamps: 4 to 11 mm (0.16 to 0.43 in)

Sample cable (does not necessarily correspond to the original cable supplied)

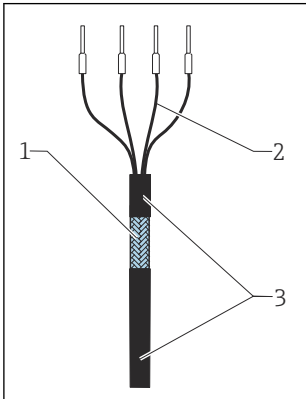

10 Terminated cable

- 1 Outer shield (exposed)
- 2 Cable cores with ferrules
- 3 Cable sheath (insulation)

1. Route the cable in such a way that the exposed cable shield fits into one of the grounding clamps and the cable cores can be easily routed as far as the terminal plugs.
2. Clamp the cable shield into the clamp.

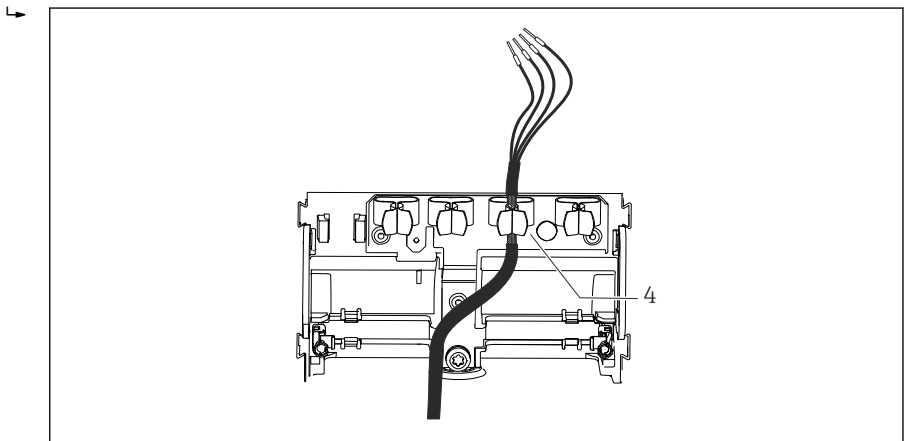

A0054922

11 Cable into grounding clamp

- 4 Grounding clamp

The cable shield is grounded by the grounding clamp. ¹⁾

3. Connect cable cores as per the wiring diagram.

1) Refer to the instructions provided in the 'Ensuring the degree of protection' section.

6.2.2 Cable terminals

1.

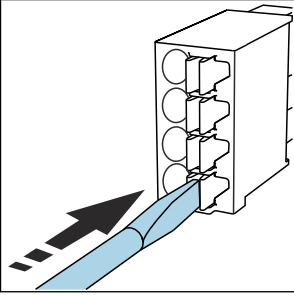

Press the screwdriver against the clip (opens the terminal).

2.

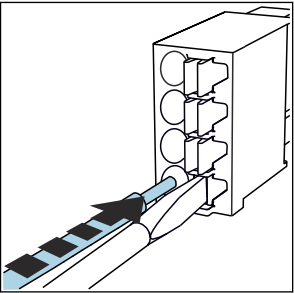

Insert the cable until the limit stop.

3.

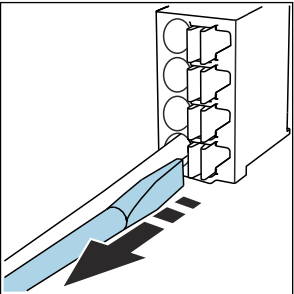

Remove the screwdriver (closes the terminal).

4. After connecting, check all the cable cores to ensure they are secure.

6.2.3 Connecting the potential equalization

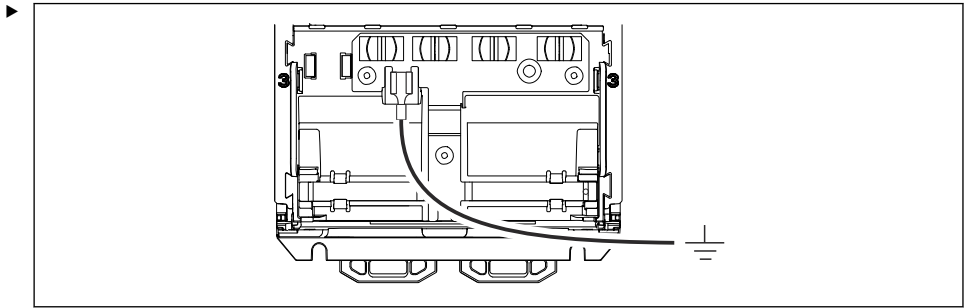

Attach the potential equalization connection to the earth or potential equalization system with a separate line. Use the preassembled 6.35 mm cable lug. Cable cross-section 1.03 to 2.62 mm² (0.002 to 0.004 in²)

6.2.4 Connecting the power supply and signal circuit

Shielded cables are required if HART (optional for current output 1) is used. If HART is not used, unshielded cables can also be used.

- ▶ Connect the current outputs with shielded two-wire cables as described in the following illustrations.

The type of shield connection depends on the anticipated interference influence. Grounding one side of the shield is sufficient to suppress electrical fields. To suppress interference due to an alternating magnetic field, the shield must be earthed on both sides.

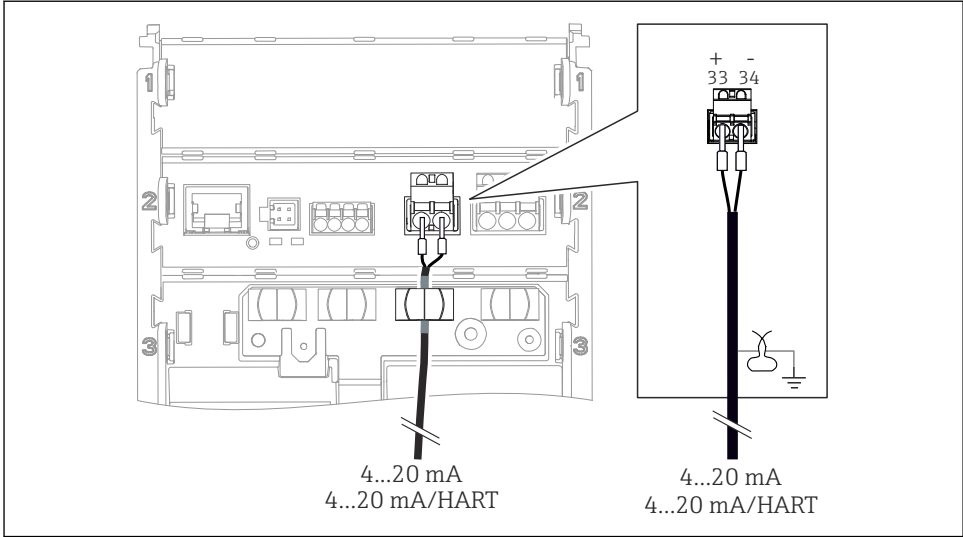

A0054900

12 Connection of 1 current output (example: device with HART)

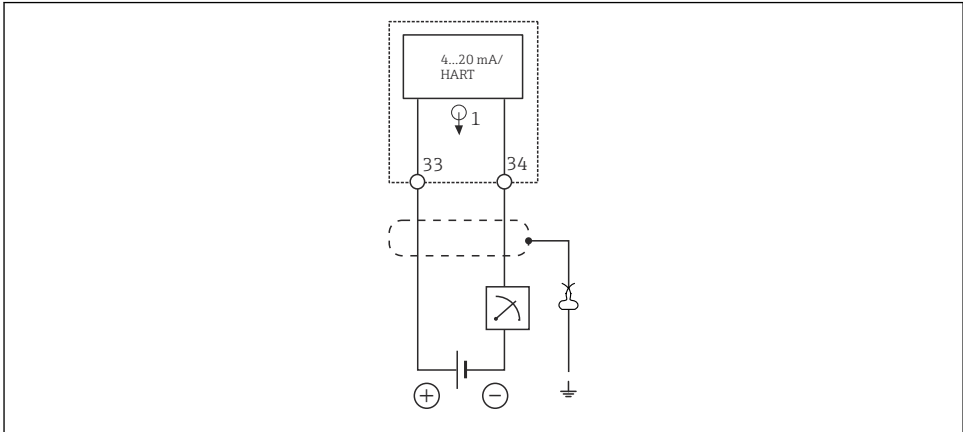

A0054914

13 Wiring diagram: 1 current output (current output with HART)

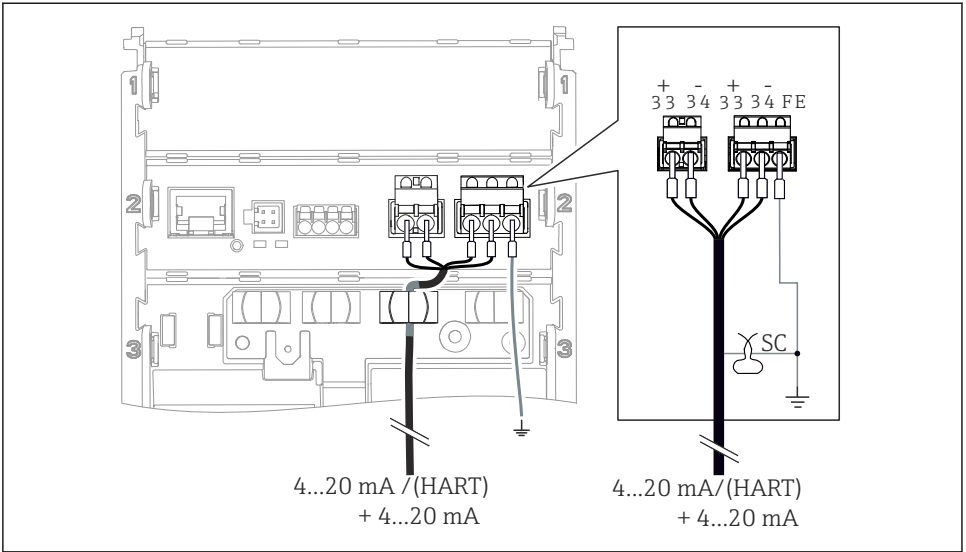

A0054901

14 Connection of 2 current outputs via 1 shielded cable (current output 1 with HART)

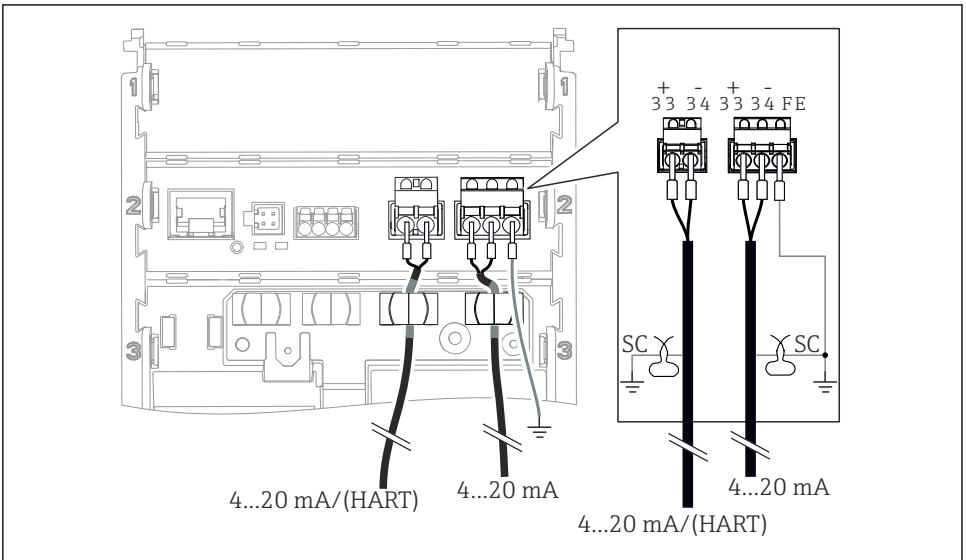

A0054902

15 Connection of 2 current outputs via 2 shielded cables (current output 1 with HART)

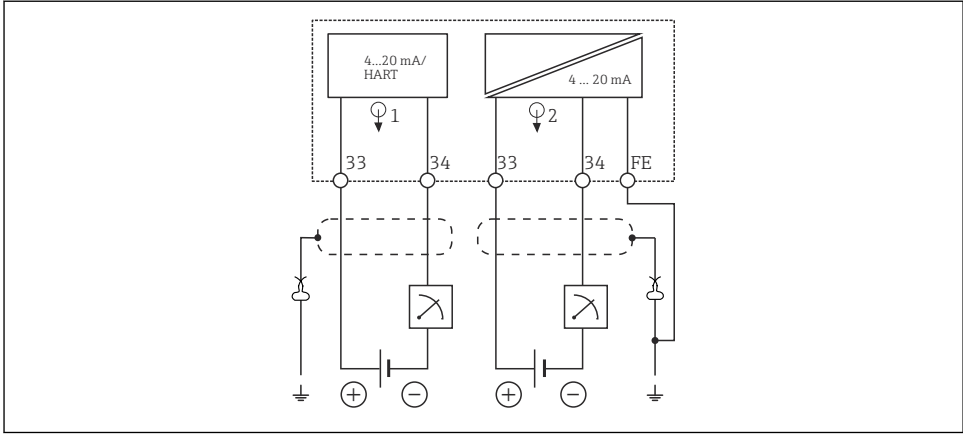

A0054915

16 Wiring diagram: 2 current outputs (current output 1 with HART)

6.2.5 Connecting the sensor

Memosens sensors

Connecting sensors with Memosens plug-in head (via Memosens cable) and sensors with a fixed cable and Memosens protocol

1.

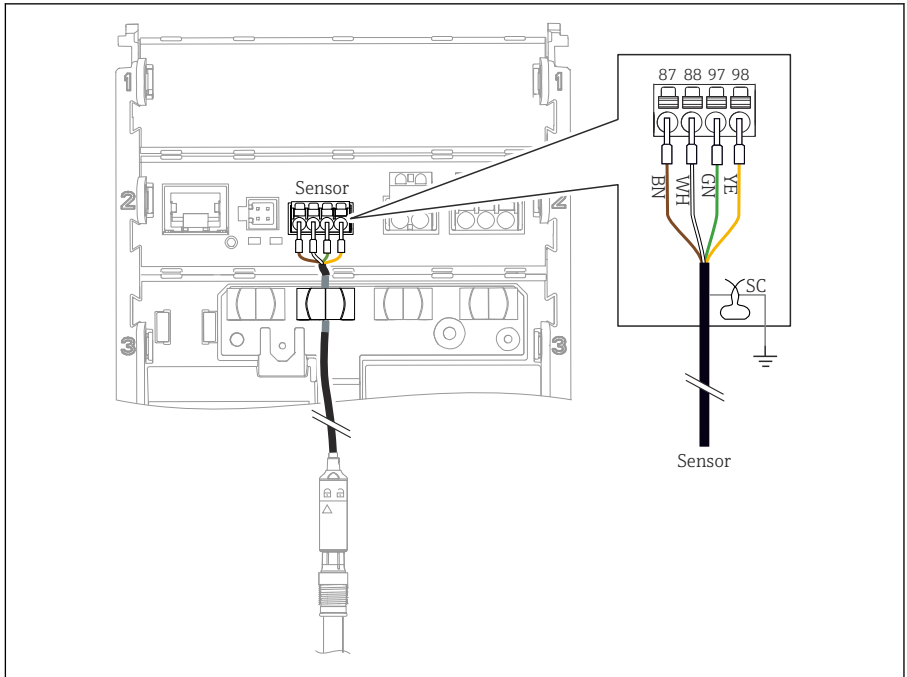

A0055579

17 Connecting Memosens sensors

Connect the sensor cable as shown in the illustration.

2. Ground the cable shield via the ground terminal.

6.3 Ensuring the degree of protection

Only the mechanical and electrical connections which are described in these instructions, and which are necessary for the required designated application, may be established on the device delivered.

► Exercise care when carrying out the work.

Individual types of protection permitted for this product (impermeability (IP), electrical safety, EMC interference immunity, explosion protection) can no longer be guaranteed if, for example:

- Covers are left off
- Different power units from the ones permitted are used
- The display is not properly secured (danger of moisture entering due to inadequate sealing)

- Cables/cable ends are loose or insufficiently tightened
- Cable shields not grounded using grounding clamp in accordance with the instructions
- Grounding is not ensured via the connection for potential equalization

6.4 Post-connection check

WARNING

Connection errors

The safety of people and of the measuring point is under threat. The manufacturer does not accept any responsibility for errors that result from failure to comply with the instructions in this manual.

- ▶ Put the device into operation only if you can answer **yes** to **all** the following questions.
 - Are the device and cable undamaged (visual inspection)?
 - Do the cables have adequate strain relief?
 - Are the cables routed without loops and cross-overs?
 - Does the supply voltage match the information on the nameplate?
 - No reverse polarity?
 - Correct terminal assignment?

7 Operation options

7.1 Overview of operation options

Operation and settings via:

- Operating elements on the device
- SmartBlue app (The full range of functions can be enabled by entering an activation code).
- Control station via HART (The full range of functions can be enabled by entering an activation code).

7.2 Access to the operating menu via the local display

7.2.1 User management

The local display menu offers user management functions with 2 user roles:

- Operator
- Maintenance

Both roles can be protected via a PIN as an option.

Set PINs

It is recommended to set PINs after initial commissioning.

1. Navigate to the path: **Menu/System/Security/Device PINs**
2. Set 4-digit PINs for the user roles. Only one PIN can be set for the **Operator** role if a PIN has already been set for the **Maintenance** role.

Overview of function access

PIN status	Device operation
No PINs set (as-delivered state)	Full access to the device menu is possible without login.
PIN set for Maintenance user role	<ul style="list-style-type: none"> ▪ The Operator user role functions can be accessed without login. ▪ Login with a PIN is required for the Maintenance user role functions. ▪ When the menu is called up, the Operator user role functions are displayed. ▪ Login with a PIN is required to access the Maintenance user role functions.
PIN set for Maintenance and Operator user roles	<ul style="list-style-type: none"> ▪ Measured values are displayed without logging in ▪ To access additional features, you must log in to a user role using the corresponding PIN. ▪ The login options for both user roles are displayed when you call up the menu.

Overview of user role access rights

User role	Access rights
Operator	<ul style="list-style-type: none"> ▪ Operating ▪ Calibration and adjustment functions ▪ Change and reset your PIN
Maintenance	<ul style="list-style-type: none"> ▪ Operating ▪ Calibration and adjustment functions ▪ Configuration and maintenance ▪ Change and reset your PIN and Operator user role PIN

7.2.2 Operating elements of the external display (optional)

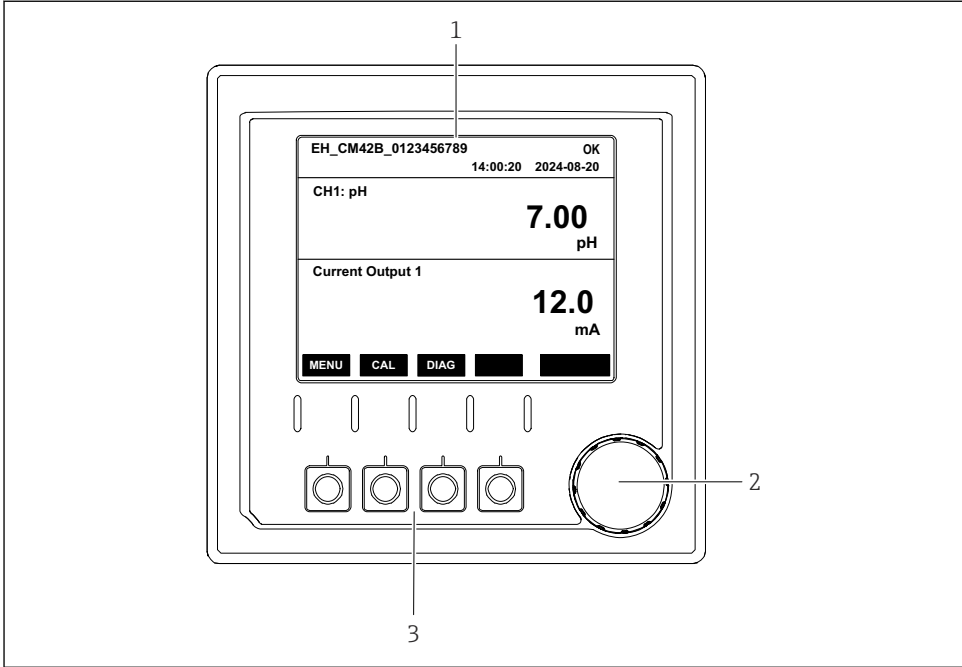

A0056333

18 Operating elements

- 1 Display
- 2 Navigator
- 3 Soft keys

7.2.3 Structure of the display

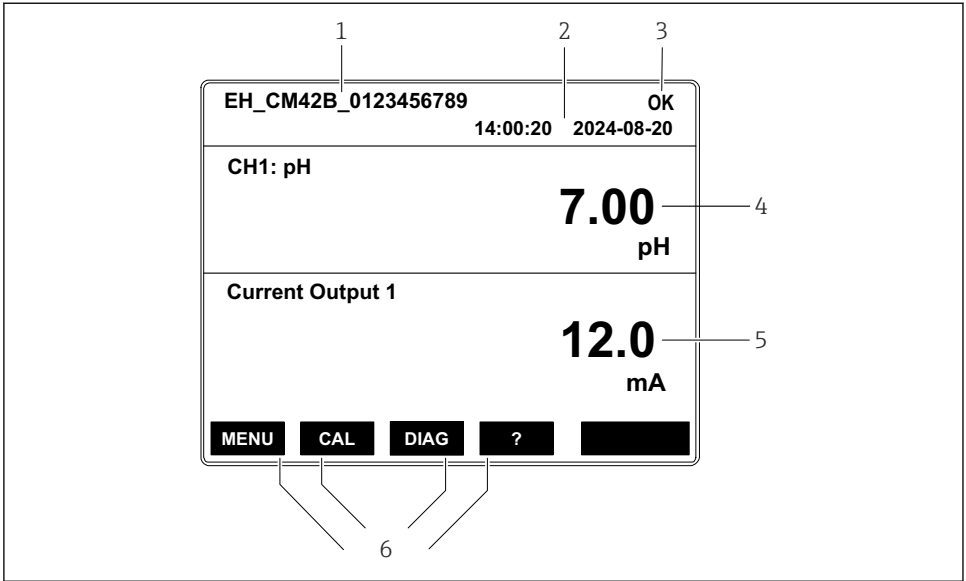

A0056328

19 Structure of the display: Start screen (device with one current output)

- 1 Device name or menu path
- 2 Date and time
- 3 Status symbols
- 4 Primary value display
- 5 Display of current output value (depending on the order, the device has 1 or 2 current outputs, the illustration shows a device with one current output)
- 6 Assignment of the soft keys

7.2.4 Navigating through the display

Measured values

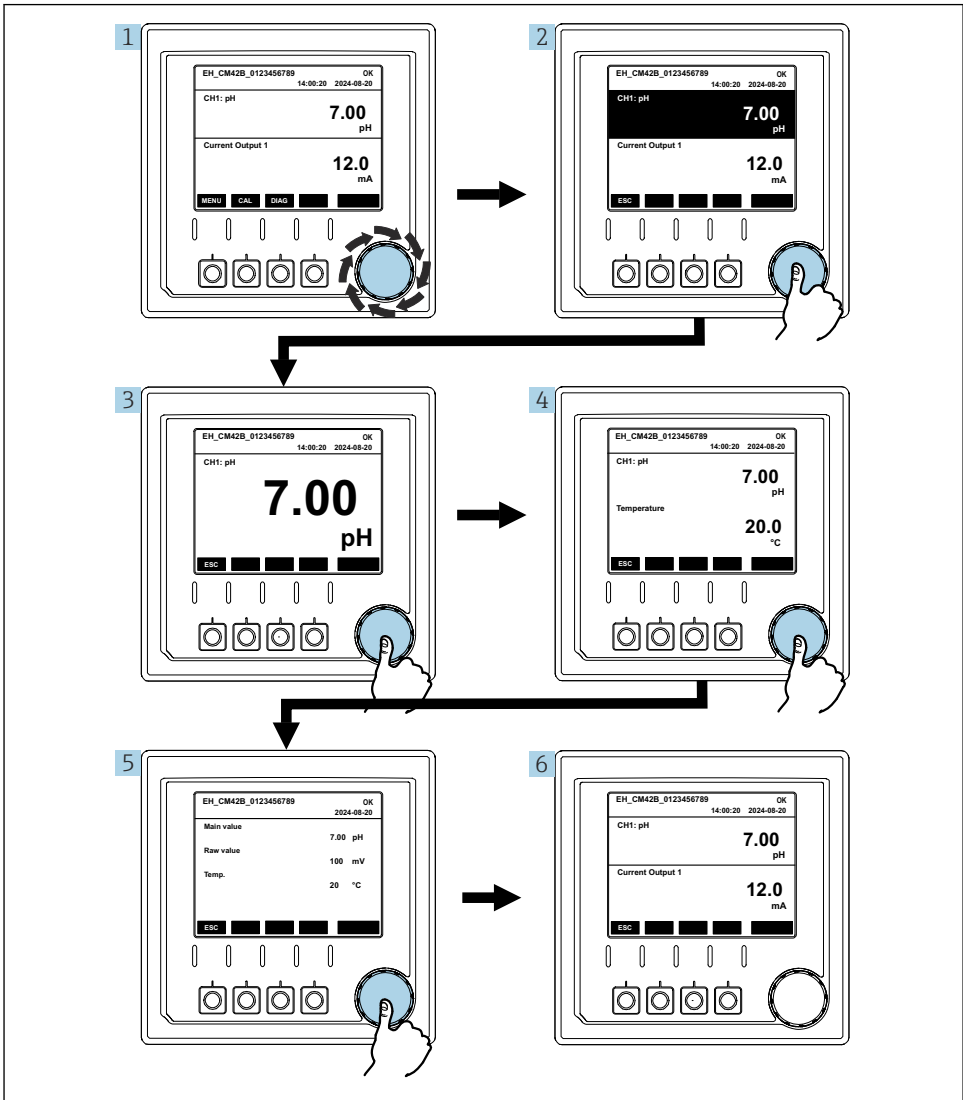

A0056209

20 Navigating through measured values

1. Press the navigator, or turn the navigator and continue turning.
 - ↳ Measured value is selected (inverted display).

2. Press the navigator.
 - ↳ The display shows the primary value.
3. Press the navigator.
 - ↳ The display shows the primary value and temperature.
4. Press the navigator.
 - ↳ The display shows the primary value, temperature and secondary measured values.
5. Press the navigator.
 - ↳ The display shows the primary value and current outputs.

Current output

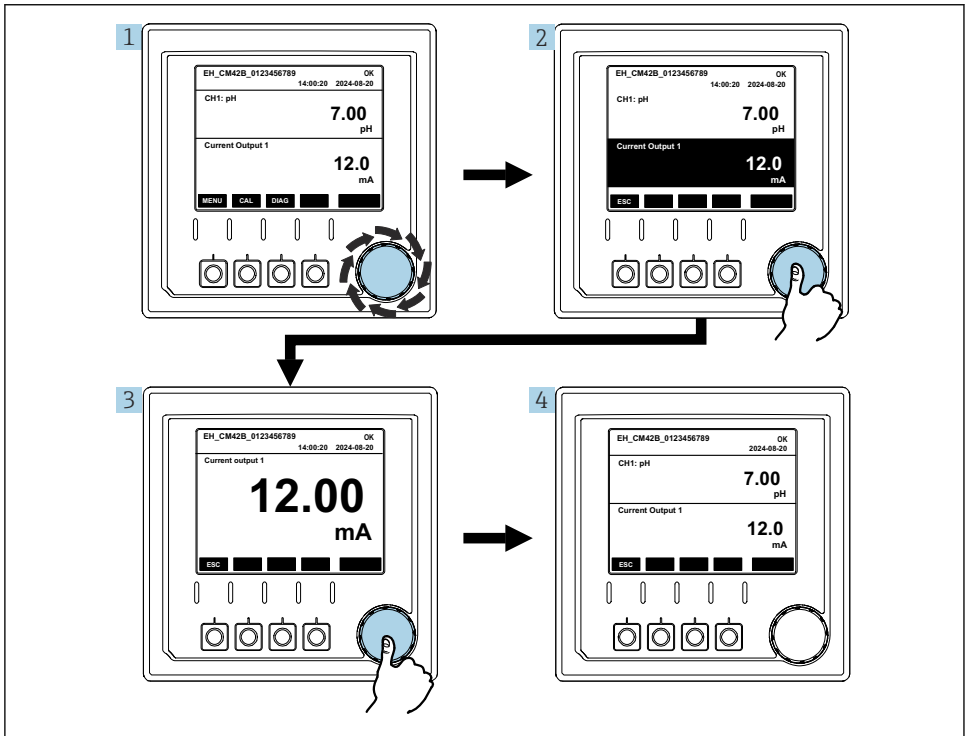

A00562.10

21 Navigation, displaying a current output

1. Press the navigator, or turn the navigator and continue turning.
 - ↳ Current output is selected (black background).
2. Press the navigator.
 - ↳ The display shows the current output details.

3. Press the navigator.
 - ↳ The display shows the primary value and current outputs.

7.2.5 Operation concept menus

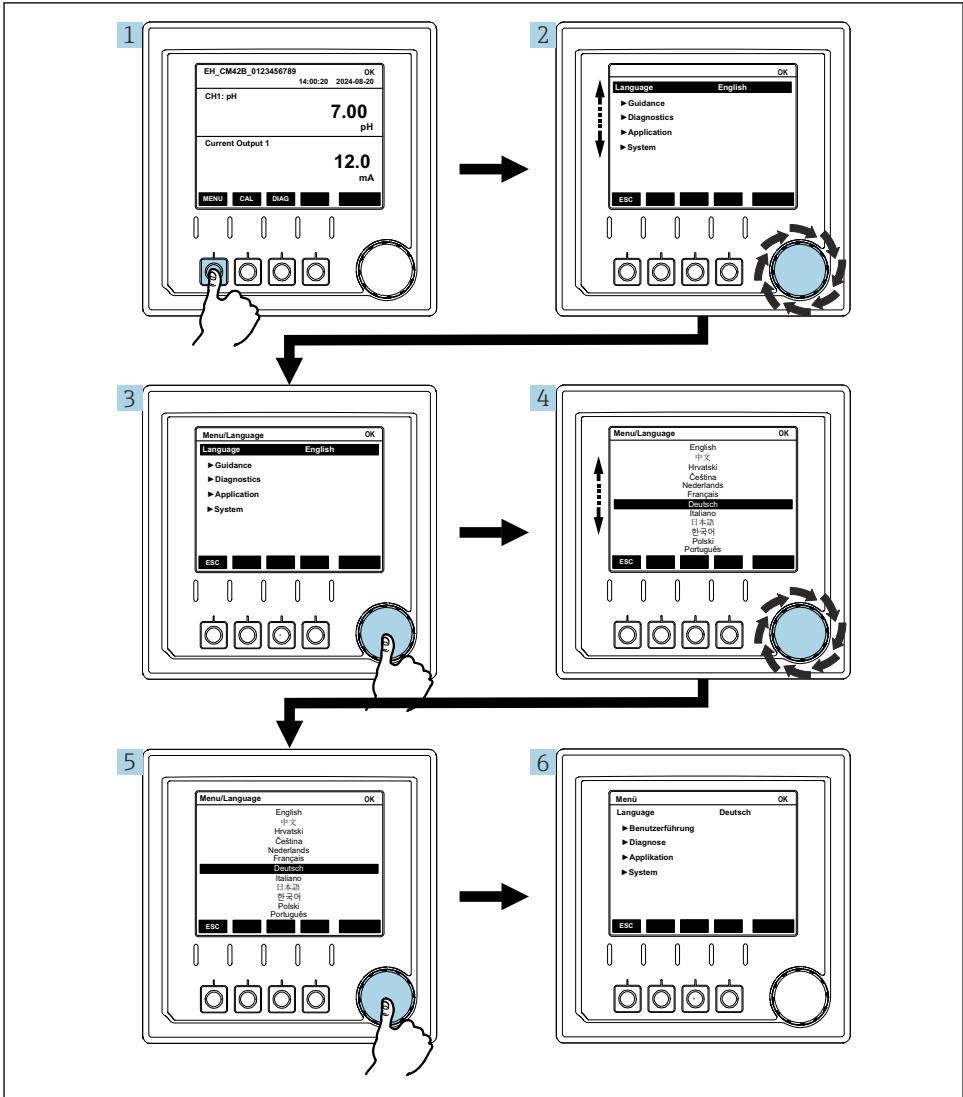

A0056305

The options available in the menu depend on the specific user authorization.

1. Press the soft key.
 - ↳ The menu is called up.
2. Turn the navigator.
 - ↳ The menu item is selected.
3. Press the navigator.
 - ↳ The function is called up.
4. Turn the navigator.
 - ↳ The value is selected (e.g. from a list).
5. Press the navigator.
 - ↳ The setting is adopted.

7.3 Access to the operating menu via the operating tool

7.3.1 Access to the operating menu via the SmartBlue app

The SmartBlue app is available to download from the Google Play Store for Android devices and from the Apple App Store for iOS devices.

System requirements

- Mobile device with Bluetooth® 4.0 or higher
- Internet access

Download the SmartBlue app:

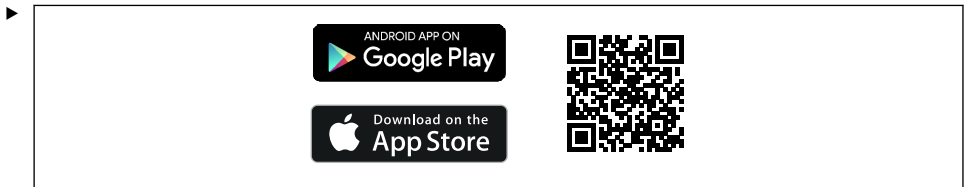

A003202

Download the SmartBlue app via a QR code.

Connect the device to the SmartBlue app:

1. Bluetooth is enabled on the mobile device.
 - Activate Bluetooth on the device: **Menu/System/Connectivity/Bluetooth**

2.



A0029747

Launch the SmartBlue app on the mobile device.

- ↳ The live list displays all of the devices that are within range.
The device in question is identified by the serial number: EH_CM42B_serial number

3. Tap the device to select it.

4. Log in with username and password.

Initial access data:

- Username: admin
- Default password: Serial number of the device



After logging in for the first time, the password can be changed and other user accounts activated.



You can drag additional information (e.g. main menu) onto the screen by swiping across the screen.



If the mainboard of the device is replaced, the default password of the admin account may change.

This is the case if a generic kit that was not ordered for the serial number of the device was used when replacing the mainboard.

In this case, the module serial number of the mainboard is the default password.

The serial number of the mainboard is saved in the device menu under: **Menu/System/Information/Modules/Mainboard**

7.3.2 Activating additional accounts in the SmartBlue app

The SmartBlue app is protected against unauthorized access by means of password-protected accounts. The authentication options of the mobile device can be used to log into the accounts.

The following accounts are available:

- Admin
- Operator
- Maintenance
- Auditor
- Recovery



The **Admin** and Recovery accounts are activated in the device as-delivered state.

Activating other user accounts

- ▶ Navigate to the path: **Menu/System/Security**

Overview of user account access rights

User account	Access rights
admin	<ul style="list-style-type: none"> ▪ Activate/deactivate user accounts ▪ Change your password and passwords of Operator, Maintenance and Auditor user accounts ▪ Security settings ▪ All other access rights for Operator, Maintenance and Auditor user accounts
Operator	<ul style="list-style-type: none"> ▪ Operating ▪ Calibration and adjustment functions ▪ Change your password
Maintenance	<ul style="list-style-type: none"> ▪ Operating ▪ Calibration and adjustment functions ▪ Configuration and maintenance ▪ Change your password
Auditor	<ul style="list-style-type: none"> ▪ Read access and export logbooks ▪ Change your password
Recovery	Reset admin password. In order to do this, please contact Endress+Hauser Service.

7.3.3 Changing passwords

Every user account can change their own password.

1. Log in with the relevant user account.
2. Navigate to the path: **Menu/System/Security**

7.3.4 Functions via the SmartBlue app

An activation code is required for full operation of the device via the SmartBlue app.

Without this activation code, the SmartBlue app offers the following functions:

- Firmware update
- **Security** menu
- Export of information for the service

7.3.5 Access to operating menu via HART and FDI

A connection can be established to Field Device Integration (FDI) via HART (optional). FDI provides access to the device's operating menu and is installed on a control station, for example. The access rights correspond to the **Maintenance** user group. The FDI packages are available in the download area of the product page.

www.endress.com/CM42B

8 System integration

8.1 Integrating the measuring instrument into the system

Interfaces for measured value transmission (depending on order):

- 4 to 20 mA current output (passive)
- Bluetooth® LE wireless technology
- HART

8.1.1 Current output

Depending on the order, the device has 1 or 2 current outputs.

- Signal range 4 to 20 mA (passive)
- The assignment of a process value to a current value is configurable within the signal range.
- Failure current can be configured from list.

8.1.2 Bluetooth® LE wireless technology

With the Bluetooth® LE wireless technology (energy-efficient wireless transmission) option that can be ordered, the device can be controlled via mobile devices.

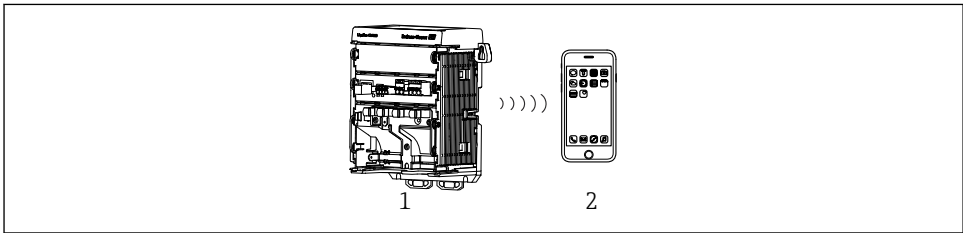

A0056364

☐ 22 Options for remote operation via Bluetooth® LE wireless technology

- 1 Transmitter with Bluetooth® LE wireless technology
- 2 Smartphone/tablet with SmartBlue app

8.1.3 HART

HART operation is possible via different hosts.

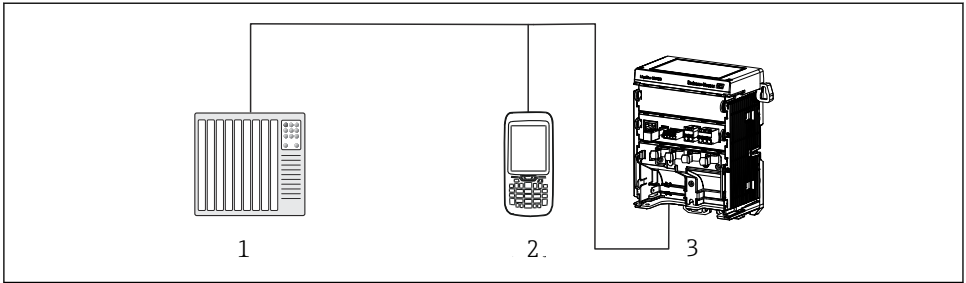

A0056314

☑ 23 *Wiring options for remote operation via HART protocol*

- 1 PLC (programmable logic controller)
- 2 HART operating device (e.g. SFX350), optional
- 3 Transmitter

The device can communicate via the HART protocol using current output 1 (depending on the order).

Follow the steps below to integrate the device into the system for this purpose:

1. Connect the HART modem or HART handheld terminal to current output 1 (communication load 250–500 Ohm).
2. Establish a connection via the HART device.
3. Operate the transmitter via the HART device. To do so, follow the HART device Operating Instructions.

9 Commissioning

9.1 Preliminaries

- ▶ Connect the device.
 - ↳ The device starts and displays the measured value.

Bluetooth® must be enabled on the mobile device for operation via the SmartBlue app.

9.2 Function check

Incorrect connection, incorrect supply voltage

Safety risks for staff and device malfunctions!

- ▶ Check that all connections have been established correctly in accordance with the wiring diagram.
- ▶ Ensure that the supply voltage matches the voltage indicated on the nameplate.

9.2.1 LED indicators

The displays use the status LEDs. The status LEDs are only active if no external display is connected to the device.

LED behavior	Status
Green Continuous	Device is in normal operating mode.
Green Flashes quickly	Starting process for the device
Red Continuous	Category F diagnostic message is present. The complete message can be seen via HART or the SmartBlue app. For information on the status signals, see
Red Flashes slowly	Category M, C or S diagnostic message is present. The complete message can be seen via HART or the SmartBlue app. For information on the status signals, see
Alternating 2x red flashes and 2x green flashes	Squawk mode is enabled. See also
Alternating 1x red flash and 1x green flash	Error during the starting process. Contact service.

9.3 Time and date

- ▶ Configure the time and date under the following path: **Menu/System/Date and time**

If you are using the Smartblue app, the date and time can also be automatically adopted from the mobile device.

9.4 Configuring the operating language

- ▶ Configure the operating language under the following path: **Menu/Language**

9.5 Transferring device parameters to other devices

The parameters of one device can be transferred to other devices with the same measuring task using the SmartBlue app or via HART.

Prerequisite(s):

- For SmartBlue app: SmartBlue app operation fully enabled via activation code.
- For HART: HART is activated and FDI (field device integration) is installed on the remote station.

Account data, passwords and logbooks are not transferred.

Downloading the parameters from the device

1. Log in to the SmartBlue app on the device from which you want to transfer the parameters using the “**Admin**” or “**Maintenance**” user account. For HART, connect to the device via FDI.
2. Navigate to the path: **Menu/Guidance/Export/Import/Parameter save:**
3. Follow the instructions in the wizard.
 - ↳ The parameters are saved on the mobile device or the remote station.

Loading the parameters onto another device

1. Log in to the SmartBlue app on the device to which you want to transfer the parameters using the “**Admin**” or “**Maintenance**” account. For HART, connect to the device via FDI.
2. Navigate to the path: **Menu/Guidance/Export/Import/Parameter load:**
3. Follow the instructions in the wizard.
 - ↳ The parameters are loaded onto the device.



Diagnostic messages F100 and C413 are enabled during the import.

The measuring function is disabled during the import.

Enable device hold if necessary.

Index

C

Cable terminals	26
Check	
Installation and function	44
Commissioning	44
Configuring the date	45
Configuring the time	45
Connection	
Electrical	23

D

Documentation	4
-------------------------	---

E

Electrical connection	23
Ensuring the degree of protection	31
Establishing connection	45

F

Function check	44
--------------------------	----

H

HART	42
----------------	----

I

Identifying the product	9
Incoming acceptance	9
Installation	11
Installation check	44
Installation requirements	11
Intended use	5
IT security	6

L

LED indicators	44
--------------------------	----

M

Measuring parameters	8
--------------------------------	---

N

Nameplate	9
Non-designated use	5

O

Operating language	45
Operating menu	32

Operation	32
Operational safety	6
P	
Post-connection check	32
Product description	7
Product design	7
Product safety	6
R	
Requirements for the personnel	5
S	
Safety	
Operation	6
Workplace safety	5
Safety information	3
Safety instructions	5
Scope of delivery	10
Symbols	3
System integration	42
T	
Technical personnel	5
U	
Use	
Intended	5
Non-designated	5
W	
Workplace safety	5



71763544

www.addresses.endress.com
