

Operating Instructions

Cleanfit CPA871

Flexible retractable process assembly for water, wastewater, chemical industry and heavy industry

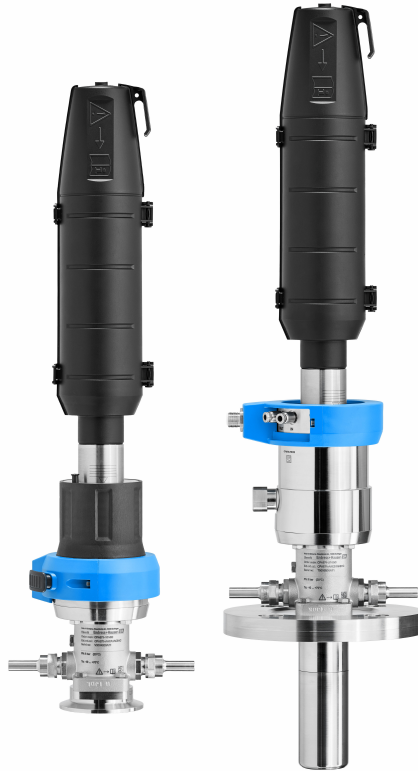









1 About this document



1.1 Safety information

Structure of information	Meaning
<p>⚠ DANGER</p> <p>Causes (/consequences) If necessary, Consequences of non-compliance (if applicable)</p> <ul style="list-style-type: none"> ▶ Corrective action 	<p>This symbol alerts you to a dangerous situation. Failure to avoid the dangerous situation will result in a fatal or serious injury.</p>
<p>⚠ WARNING</p> <p>Causes (/consequences) If necessary, Consequences of non-compliance (if applicable)</p> <ul style="list-style-type: none"> ▶ Corrective action 	<p>This symbol alerts you to a dangerous situation. Failure to avoid the dangerous situation can result in a fatal or serious injury.</p>
<p>⚠ CAUTION</p> <p>Causes (/consequences) If necessary, Consequences of non-compliance (if applicable)</p> <ul style="list-style-type: none"> ▶ Corrective action 	<p>This symbol alerts you to a dangerous situation. Failure to avoid this situation can result in minor or more serious injuries.</p>
<p>NOTICE</p> <p>Cause/situation If necessary, Consequences of non-compliance (if applicable)</p> <ul style="list-style-type: none"> ▶ Action/note 	<p>This symbol alerts you to situations which may result in damage to property.</p>

1.2 Symbols

-  Additional information, tips
-  Permitted
-  Recommended
-  Not permitted or not recommended
-  Reference to device documentation
-  Reference to page
-  Reference to graphic
-  Result of an individual step

1.2.1 Symbols on the device

-  Reference to device documentation
-  Do not dispose of products bearing this marking as unsorted municipal waste. Instead, return them to the manufacturer for disposal under the applicable conditions.

2 Basic safety instructions

2.1 Requirements for the personnel

- Installation, commissioning, operation and maintenance of the measuring system may be carried out only by specially trained technical personnel.
- The technical personnel must be authorized by the plant operator to carry out the specified activities.
- The electrical connection may be performed only by an electrical technician.
- The technical personnel must have read and understood these Operating Instructions and must follow the instructions contained therein.
- Faults at the measuring point may only be rectified by authorized and specially trained personnel.



Repairs not described in the Operating Instructions provided must be carried out only directly at the manufacturer's site or by the service organization.

2.2 Intended use

The Cleanfit CPA871 retractable assembly, which can be manually or pneumatically operated, is designed for the installation of sensors in vessels and pipes.

Thanks to its design, it can be operated in pressurized systems (→  78).

Any use other than that intended puts the safety of people and the measuring system at risk. Therefore, any other use is not permitted.

The manufacturer is not liable for harm caused by improper or unintended use.

2.2.1 Use in explosion-proof areas

As a manufacturer of products used for analysis, we declare that the product supplied has undergone an ignition risk assessment and may be used in hazardous atmospheres once the following conditions for safe usage have been met:

- The protective ring is labeled as follows: "CAUTION, DANGER DUE TO ELECTROSTATIC CHARGES, CLEAN USING ONLY AN ANTISTATIC CLOTH". This instruction must be observed.
- Assemblies comprising wetted parts made of non-conductive material, must not be used in potentially explosive atmospheres.
- The compressed air supply, sensors and limit position switches must comply with the applicable guidelines and standards for use in hazardous atmospheres, be labeled with the degree of protection and meet the requirements of the relevant range of application. The ambient temperatures must be observed. The limit position switch used in the product complies with this requirement.
- Ensure that the compressed air does not contain a potentially explosive atmosphere.
- Please ensure that movements associated with the retraction and insertion of the sensor do not damage the connection.
- The product must be incorporated into the local potential equalization system.
- The Operating Instructions for the product and in particular the conditions for safe usage must be read, understood and implemented.

The product does not need to be labeled with the degree of protection.

2.3 Workplace safety

The operator is responsible for ensuring compliance with the following safety regulations:

- Installation guidelines
- Local standards and regulations

2.4 Operational safety

Before commissioning the entire measuring point:

1. Verify that all connections are correct.
2. Ensure that electrical cables and hose connections are undamaged.

Procedure for damaged products:

1. Do not operate damaged products, and protect them against unintentional operation.
2. Label damaged products as defective.

During operation:

- ▶ If errors cannot be rectified,
take products out of service and protect them against unintentional operation.

2.5 Product safety

2.5.1 State-of-the-art technology

The product is designed to meet state-of-the-art safety requirements, has been tested, and left the factory in a condition in which it is safe to operate. The relevant regulations and international standards have been observed.

3 Product description

3.1 Product design

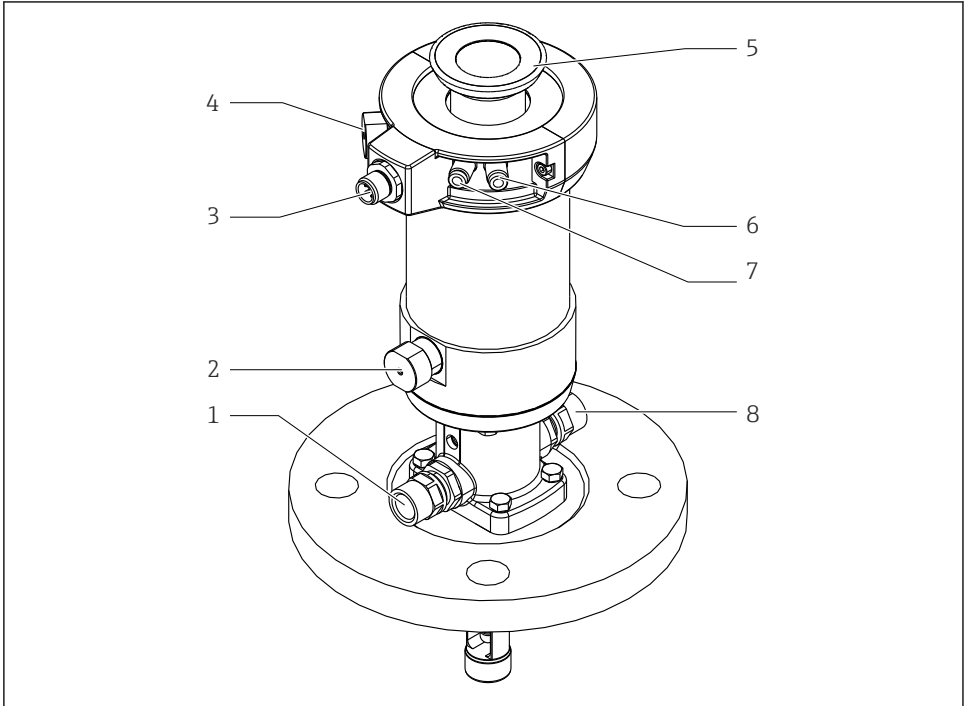

A0029614

1 Assembly with pneumatic drive (without protective cover)

- 1 Rinse connection (outlet)
- 2 Automatic limit position lock, process
- 3 Connection for limit position switch
- 4 Automatic limit position lock, service
- 5 Fastening ring for protective cover
- 6 Pneumatic connection (move to measuring position)
- 7 Pneumatic connection (move to service position)
- 8 Rinse connection (inlet)

3.1.1 Operating principle

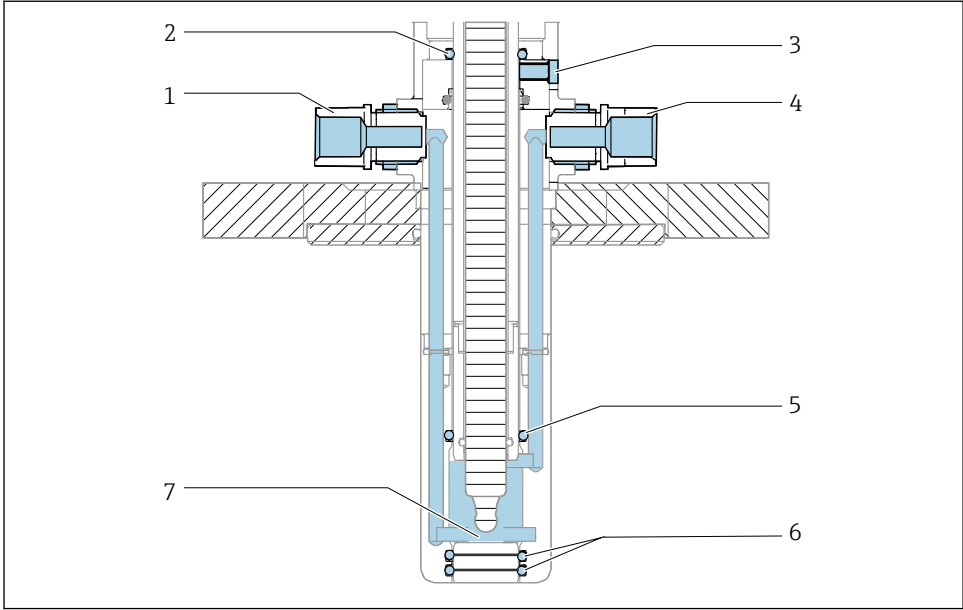

A0039361

2 Sealing system, assembly in service position

- 1 Rinse chamber, inlet
- 2 Seal drive (1 x O-ring)
- 3 Leakage hole
- 4 Rinse chamber, outlet
- 5 Seal, rinse chamber (1 x O-ring)
- 6 Process seal (2 x O-ring)
- 7 Rinse chamber

The assembly is open to the process during insertion/retraction; the rinse connections must either be pipe-fitted or sealed.

The assembly has a pin seal. This seals the assembly from the process in the relevant limit position.

Process seal

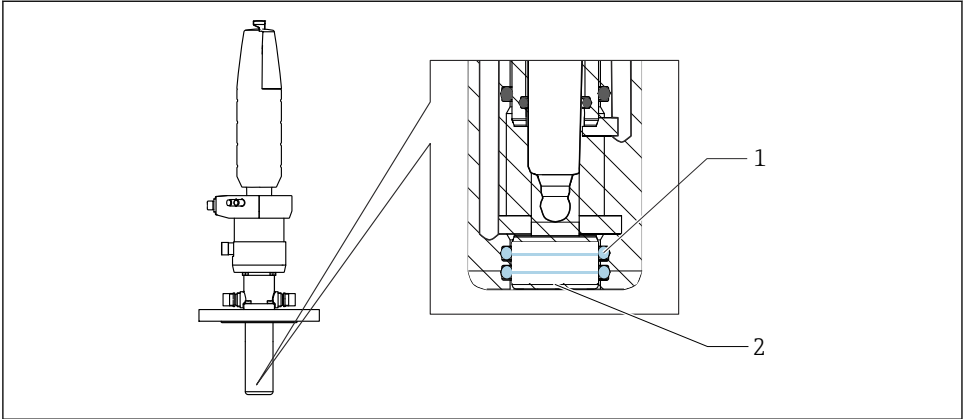

A0039106

3 *Process seal, assembly in service position*

1 *Process seal (2 x O-ring)*

2 *Pin*

4 Incoming acceptance and product identification

4.1 Incoming acceptance

1. Verify that the packaging is undamaged.
 - ↳ Notify the supplier of any damage to the packaging.
Keep the damaged packaging until the issue has been resolved.
2. Verify that the contents are undamaged.
 - ↳ Notify the supplier of any damage to the delivery contents.
Keep the damaged goods until the issue has been resolved.
3. Check that the delivery is complete and nothing is missing.
 - ↳ Compare the shipping documents with your order.
4. Pack the product for storage and transportation in such a way that it is protected against impact and moisture.
 - ↳ The original packaging offers the best protection.
Make sure to comply with the permitted ambient conditions.

If you have any questions, please contact your supplier or your local Sales Center.

4.2 Scope of delivery

The scope of delivery comprises:

- Assembly in the version ordered
- Operating Instructions
- Adapter for plug-in connector, 6 mm (0.24 in) to 4 mm (0.16 in) (outer diameter)
- Optional accessories ordered

4.3 Product identification

4.3.1 Nameplate

The nameplate provides you with the following information on your device:

- Manufacturer identification
- Order code
- Extended order code
- Serial number
- Ambient and process conditions
- Safety information and warnings

► Compare the information on the nameplate with the order.

4.3.2 Identifying the product

The order code and serial number of your product can be found in the following locations:

- On the nameplate
- In the delivery papers

Obtaining information on the product

1. Go to www.endress.com.
2. Page search (magnifying glass symbol): Enter valid serial number.
3. Search (magnifying glass).
 - ↳ The product structure is displayed in a popup window.
4. Click the product overview.
 - ↳ A new window opens. Here you will find information pertaining to your device, including the product documentation.

Product page

www.endress.com/CPA871

Manufacturer address

Endress+Hauser Conducta GmbH+Co. KG
Dieselstraße 24
70839 Gerlingen
Germany

5 Installation

5.1 Installation requirements

5.1.1 Orientation

NOTICE

Frost damage to the assembly

- ▶ If used outdoors, ensure that water cannot penetrate the drive.

The assembly is designed to be mounted on vessels and pipes. Suitable process connections must be available for this.

The assembly is designed in such a way that there are no restrictions with regard to the orientation.



The sensor that is used can restrict the orientation.



Ensure compliance with the Operating Instructions of the sensor installed.

Installation free of dead space

A measurement in the dead space is inaccurate due to the low exchange of medium.

- ▶ Install the assembly in such a way that measurement is not possible in the dead space.

Configure the installation in such a way that dimension X1, reduced by the distance between the measuring elements n (in the case of pH sensors 20 mm (0.8 in)), exceeds dimension F1 (distance between the process connection support and the inside of the pipe).

When installing inside a pipe, make sure the sensor guide does not hit the opposite wall. To do this, ensure that dimension X2 is smaller than dimension F2 (distance between process connection and inside of pipe).

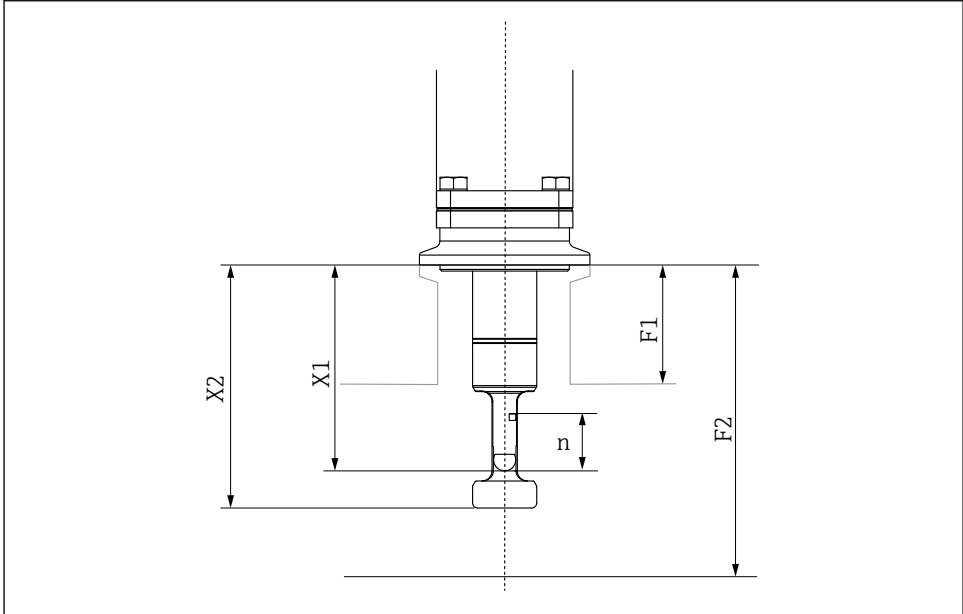

A0061147

n 20 mm (0.8 in)

F1 Refers to the system; customer's specific situation

F2 Refers to the system; customer's specific situation

X1 Dimensions of process assemblies CPA87x

X2 Dimensions of process assemblies CPA87x

5.1.2 Dimensions

Short version

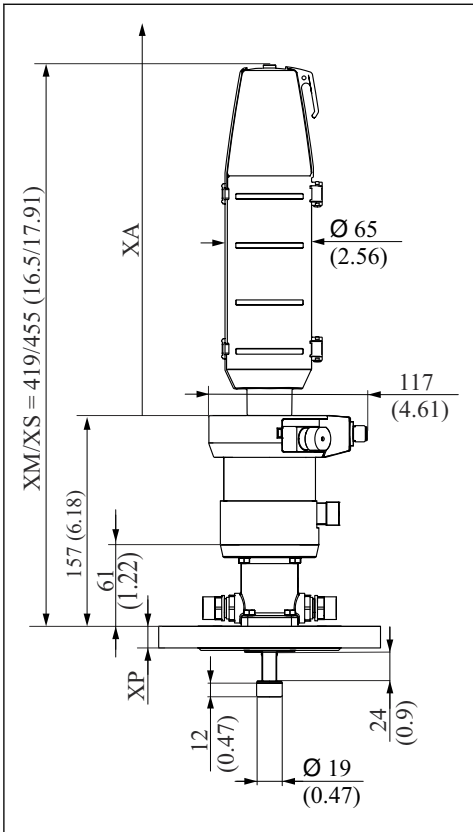

A0023894

4 Pneumatic drive, short version, dimensions in mm (in)

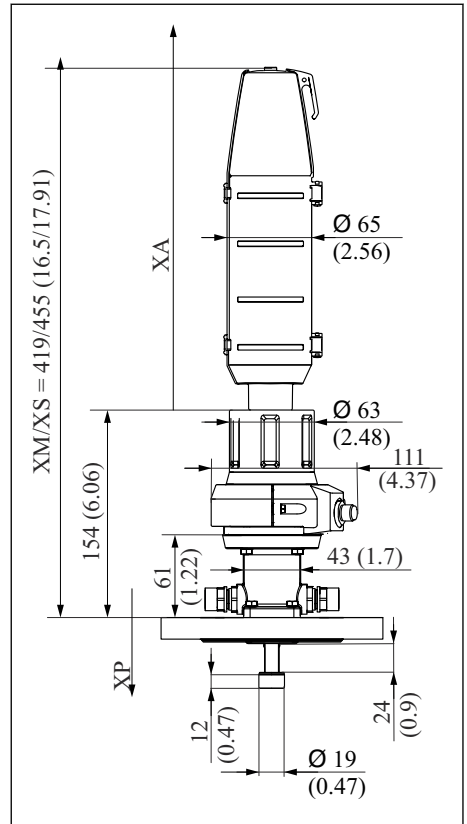

A0023897

5 Manual drive, short version, dimensions in mm (in)

XM Assembly in measuring position

XS Assembly in service position

XP Height of particular process connection (see table below)

XA Necessary mounting distance for sensor replacement

A free path length XA above the drive is required to replace the sensors:

XA is 280 mm (11.02 in) for 120 mm sensors

XA is 408 mm (15.94 in) for 225 mm sensors

Long version

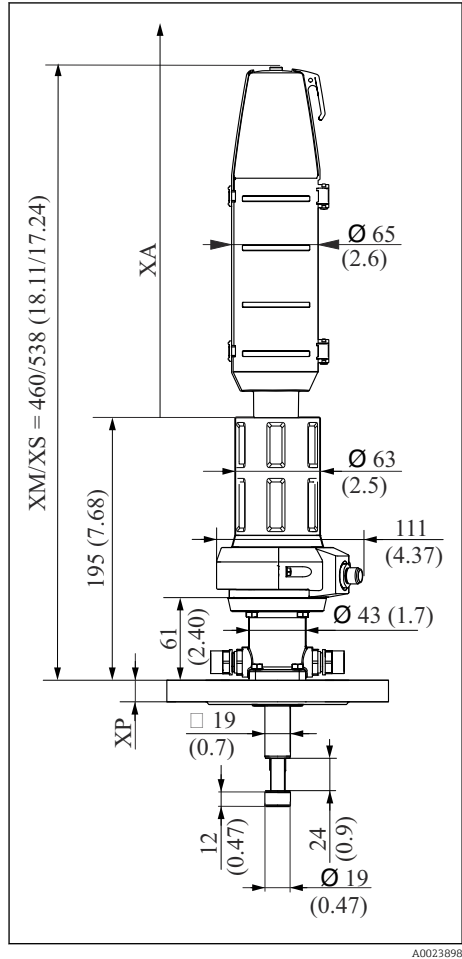
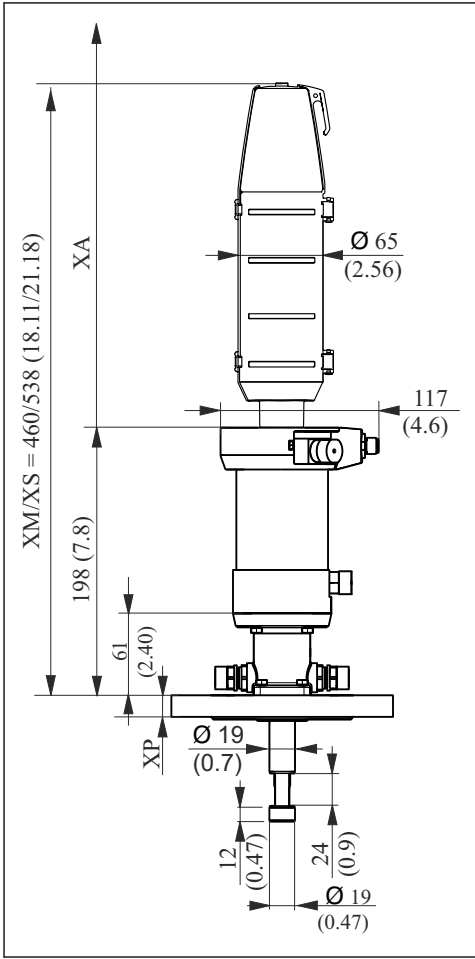

6 *Pneumatic drive, long version, dimensions in mm (in)*

7 *Manual drive, long version, dimensions in mm (in)*

XM Assembly in measuring position

XS Assembly in service position

XP Height of particular process connection (see table below)

XA Necessary mounting distance for sensor replacement

A free path length XA above the drive is required to replace the sensors:

XA is 360 mm (14.17 in) for 225 mm sensors

XA is 582 mm (22.91 in) for 360 mm sensors including KCI

Immersion chamber version

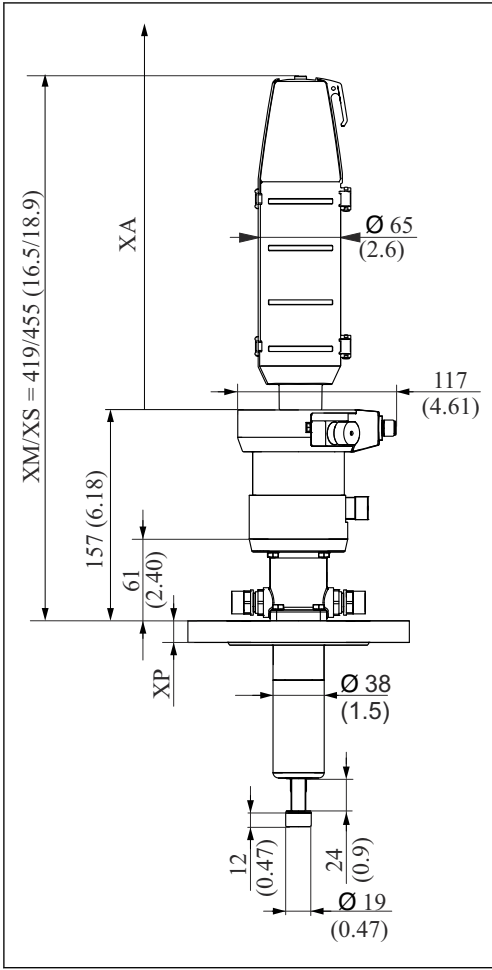

8 Immersion chamber version with pneumatic drive, dimensions in mm (in)

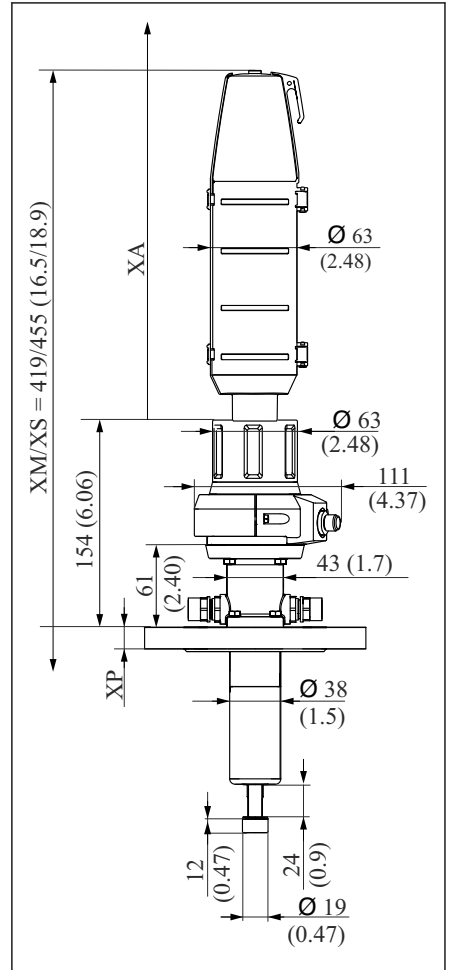

9 Immersion chamber version with manual drive, dimensions in mm (in)

XM Assembly in measuring position

XS Assembly in service position

XP Height of particular process connection (see table below)







XA Necessary mounting distance for sensor replacement

A free path length XA above the drive is required to replace the sensors:

XA is 280 mm (11.02 in) for 225 mm sensors

XA is 570 mm (22.44 in) for 360 mm sensors

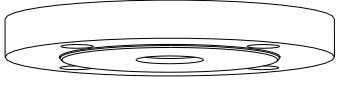
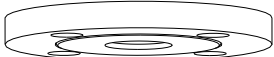
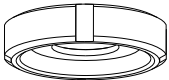
Process connection height

Process connection		Height XP in mm (in)
CB Clamp 2" ISO 2852, ASME BPE-2012	 A0024100	16 (0.63)
FA Flange DN 40 PN16, EN 1092-1	 A0024102	18 (0.71)
FB Flange DN 50 PN16, EN 1092-1	 A0024103	18 (0.71)
FC Flange DN 80 PN10, EN 1092-1	 A0024104	20 (0.79)
FD Flange 2" 150 lbs, ASME B16.5	 A0024105	19.1 (0.75)
FE Flange 3" 150 lbs, ASME B16.5	 A0024106	23.8 (0.94)
FF 10K50, JIS B2220	 A0024107	16 (0.63)
MA Dairy fitting DN 50 DIN 11851	 A0024109	15.5 (0.61)
MB Dairy fitting DN 65 DIN 11851	 A0024110	15.5 (0.61)

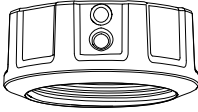
Process connection		Height XP in mm (in)
HB Thread NPT 1½"	 <p style="text-align: right; font-size: small;">A0024111</p>	40.5 (1.57)
NA DN 25 G1¼" female thread <ul style="list-style-type: none"> ▪ Thread ISO 228 G1¼ ▪ Compatible with hook wrench, DIN 1810 flat face <p>NOTICE</p> <p>Mounting with pipe wrench causes damage.</p> <p>► Use a hook wrench for mounting and removal.</p>	 <p style="text-align: right; font-size: small;">A0054908</p>	31.1 (1.22) (Union nut 22.5 (0.89))

5.1.3 Immersion depths

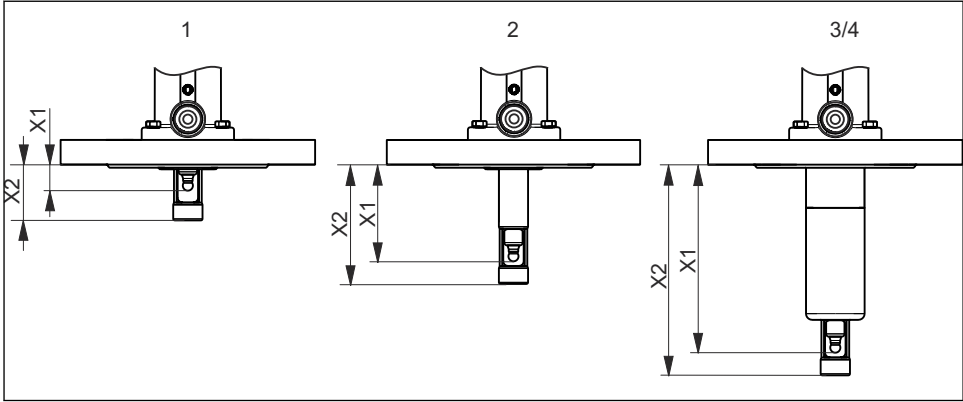

A0023893

10 Immersion depths in mm (in)

- 1 Short stroke, 36 mm (1.42 in)
- 2 Long stroke, 78 mm (3.07 in)
- 3 Immersion chamber version, 99 mm (3.89 in) / 36 mm (1.42 in)
- 4 Long immersion chamber version, 151 mm (5.94 in) / 36 mm (1.42 in)

Versions

Process connection		1	2	3	4
CB Clamp ISO 2852 ASME BPE-2012 2"	X1	14.9 (0.59)	61.0 (2.40)	119.9 (4.72)	171.9 (6.76)
	X2	34.2(1.35)	75.7 (2.98)	134.6 (5.30)	186.6 (7.35)
FA Flange DN 40 EN 1092-1	X1	14.9 (0.59)	61.0 (2.40)	119.9 (4.72)	171.9 (6.76)
	X2	34.2(1.35)	75.7 (2.98)	134.6 (5.30)	186.6 (7.35)
FB Flange DN 50 EN 1092-1	X1	14.9 (0.59)	61.0 (2.40)	119.9 (4.72)	171.9 (6.76)
	X2	34.2(1.35)	75.7 (2.98)	134.6 (5.30)	186.6 (7.35)
FC Flange DN 80 EN 1092-1	X1	12.9 (0.51)	59.0 (2.32)	117.9 (4.64)	169.9 (6.69)
	X2	32.2(1.27)	73.7 (2.90)	132.6 (5.22)	184.6 (7.27)
FD Flange 2" 150 lbs ASME B16.5	X1	13.8 (0.54)	59.9 (2.36)	118.9 (4.68)	170.9 (6.73)
	X2	33.1 (1.30)	74.6 (2.94)	133.6 (5.26)	185.6 (7.30)
FE Flange 3" 150 lbs ASME B16.5	X1	-	-	114.1 (4.49)	166.1 (6.54)
	X2	-	-	128.8 (5.07)	180.8 (7.11)
FF Flange 10K50 JIS B2220	X1	14.4 (0.57)	61.3 (2.41)	120.2 (4.73)	172.2 (6.78)
	X2	33.7 (1.33)	76.0 (2.99)	134.9 (5.31)	186.9 (7.36)
HB Thread NPT 1½"	X1	-	63.0 (2.48)	121.9 (4.80)	173.9 (6.85)
	X2	-	77.7 (3.06)	136.6 (5.38)	188.6 (7.40)
MA Dairy fitting DN 50 DIN 11851	X1	15.4 (0.61)	61.5 (2.42)	120.4 (4.74)	172.4 (6.79)
	X2	34.7 (1.37)	76.2 (3.00)	135.1 (5.32)	187.1 (6.37)

Process connection		1	2	3	4
MB Dairy fitting DN 65 DIN 11851	X1	15.4 (0.61)	61.5 (2.42)	120.4 (4.74)	172.4 (6.79)
	X2	34.7 (1.37)	76.2 (3.00)	135.1 (5.32)	187.1 (6.37)
NA thread ISO 228 G 1¼	X1	-	61.5 (2.42)	-	-
	X2	-	76.2 (3.00)	-	-
	X3	-	20.6 (0.81)	-	-

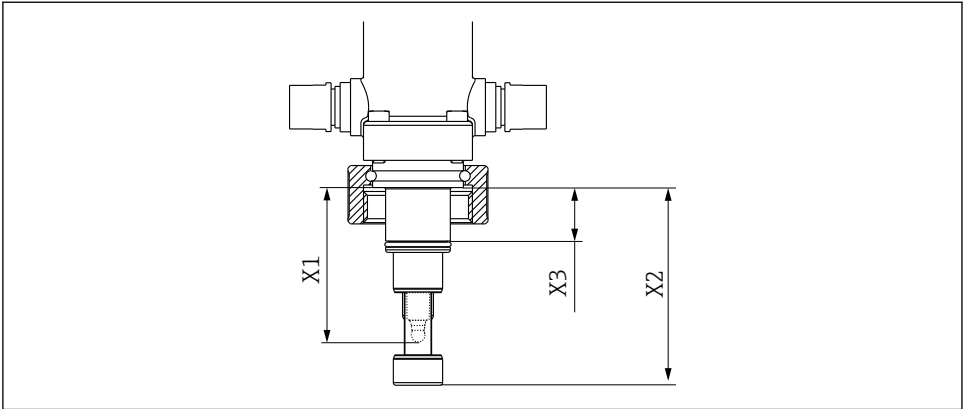

A0039342

11 Immersion depth in mm (in) for process connection NA thread ISO 228 G1¼

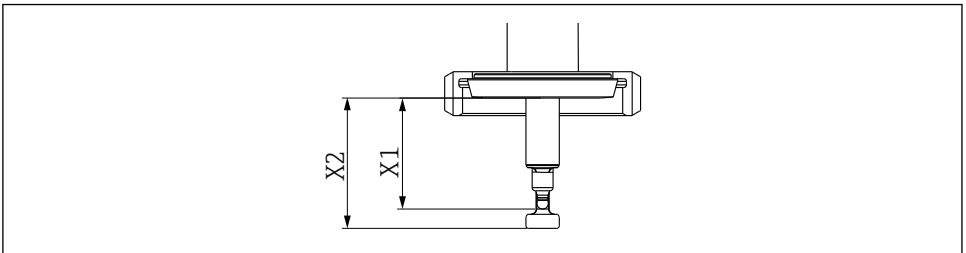

A0048452

12 Immersion depth in mm (in) for process connection MA and MB thread

5.2 Installing the assembly

5.2.1 Installation procedure

Measuring system

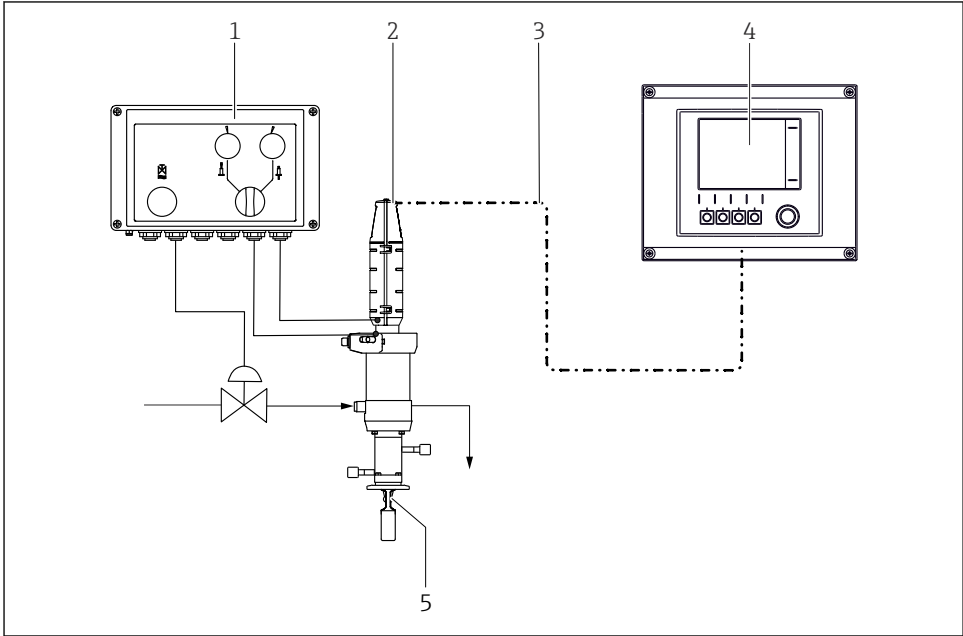

A0017811

13 Measuring system (example)

- 1 Air-Trol CYC10 control unit
- 2 Cleanfit CPA871 assembly
- 3 Measuring cable
- 4 Liquiline CM44x transmitter
- 5 Sensor

Installation recommendation

CAUTION

There is a direct connection between the process and the service chamber when the assembly is inserted/retracted. Medium can escape through the service chamber connections.

Risk of injury from escaping process medium.

- ▶ Connect the service chamber connections.
- ▶ Check all connections for leaks prior to commissioning.

NOTICE

There is a connection between the process and the service chamber during insertion/retraction.

Contamination of the assembly.

- ▶ Include the assembly in the cleaning concept.
- ▶ Ensure regular cleaning.

The process seals seal the process in the relevant end position. The assembly is open to the process during insertion/retraction; the rinse connections must either be pipe-fitted or sealed.

i The connection between the service chamber and the process is open during movement; the sealing water function can be used as a result. The rinse chamber outlet must be blocked (e.g., with a shutoff valve) to implement the sealing water function.

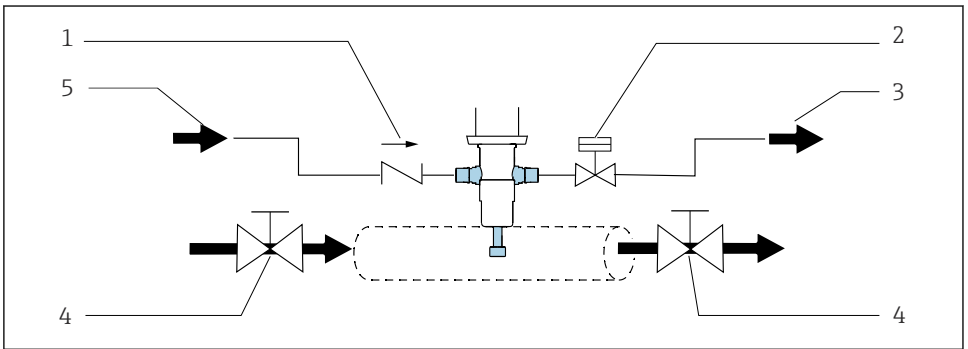

A0039105

14 Installation suggestion for seal system using a bypass

- 1 Check valve
- 2 Valve open/closed, sealing water function
- 3 Wastewater
- 4 Shutoff valve open/closed (optional)
- 5 Water/cleaning agent

The seals must be checked and serviced regularly. Therefore measures must be taken to separate the assembly from the process, e.g., by installing in a bypass.

Installing/removing the assembly from the process

⚠ WARNING

Risk of injury from high pressure, high temperature or chemical hazards if process medium escapes.

- ▶ Wear protective gloves, protective goggles and protective clothing.
- ▶ Mount the assembly only if vessels or pipes are empty and unpressurized.

i Prior to installation, check the flange seal between the flanges.

1. Move the assembly to the service position.
↳ (The triangle position marking is visible (→  15)).
2. Secure the assembly on the tank or piping via the process connection.
3. Follow the instructions in the next section to connect pipes for compressed air and rinse water (for the relevant assembly version).

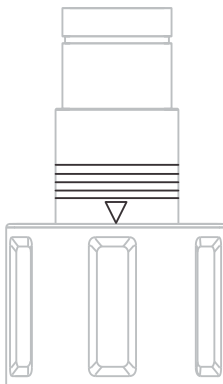

A0023307

 15 Position markings (service position)

Pneumatic connection for automatic operation

Prerequisites:

- Air pressure 5 to 8 bar (72 to 116 psi) (absolute) or air pressure 4 to 7 bar (58 to 102 psi)(relative)
- Compressed air quality in accordance with ISO 8573-1:2001 Quality class 3.3.3 or 3.4.3
- Solids class 3 (max. 5 µm, max. 5 mg/m³, contamination with particles)
- Water content for temperatures ≥ 15 °C (59 °F): Class 4 pressure dew point 3 °C (37 °F) or lower
- Water content for temperatures 5 to 15 °C (41 to 59 °F): Class 3 pressure dew point -20 °C (-4 °F) or lower
- Oil content: Class 3 (max. 1 mg/m³)
- Air temperature: 5 °C (41 °F) or higher
- Minimum nominal diameter of the air lines: 2 mm (0.08 in)

A dual-operating cylinder is used to operate the pneumatic drive.

An automatic limit position lock both in service and measuring position secures the assembly to prevent it from moving inadvertently in the event of a failure in the control air. The assembly remains in the relevant position.

Connection: Plug-in connector M5, hose 4/2 mm OD/ID (adapter for 6/4 mm OD/ID enclosed)

NOTICE

Air pressure too high

Damage to seals.

- ▶ Install a pressure-reducing valve upstream if the air pressure is likely to increase to more than 7 bar (102 psi) (absolute) (even short pressure surges).

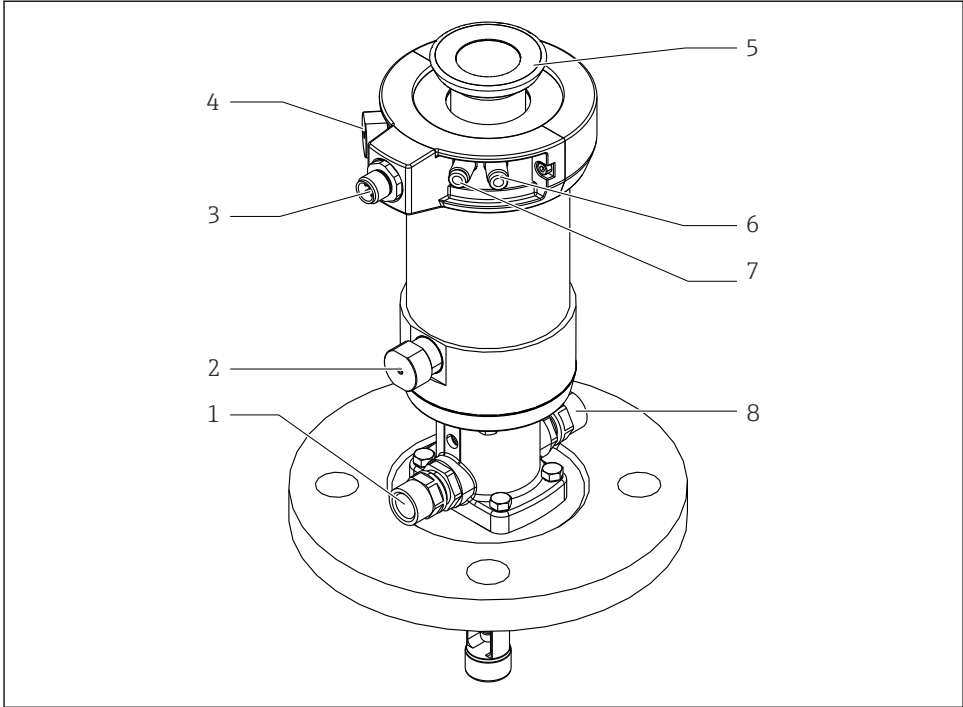

A0029614

16 *Assembly with pneumatic drive (without protective cover)*

- 1 Rinse connection
- 2 Automatic limit position lock, process
- 3 Connection for limit position switch, optional
- 4 Automatic limit position lock, service
- 5 Fastening ring for protective cover
- 6 Pneumatic connection (move to measuring position)
- 7 Pneumatic connection (move to service position)
- 8 Rinse connection

i Use a pneumatic pilot valve (4/2-way or 5/2-way) to insert/retract the assembly. Connect the two inputs of the assembly.

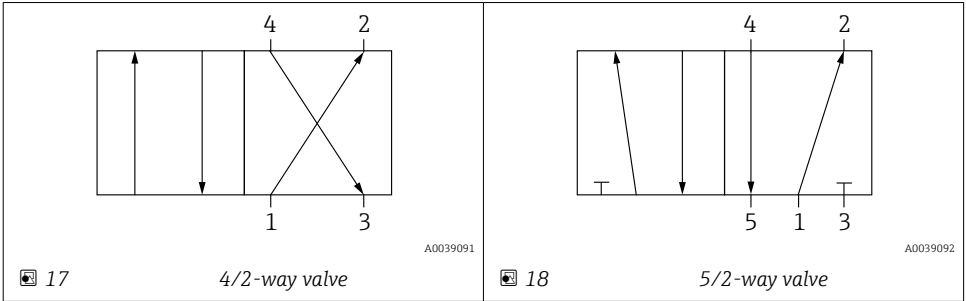

Connection 1 is attached to the compressed air supply.

Connections 2 and 4 are used to attach to the pneumatic drive.

Connection 3 and, if present, connection 5 are not attached; they are used to vent the drive.

Rinse connections

The service chamber connections make it possible to rinse the chamber (including the sensor) with water or cleaning solution. The pressure difference between the sealing water and process must not exceed 6 bar (87 psi).

The sealing water pressure must not exceed 8 bar (116 psi) in manual mode and 16 bar (232 psi) in pneumatic mode.

i Install a pressure-reducing valve upstream if there is the possibility that water pressures can exceed the specified sealing water pressure (8 bar (116 psi) or 16 bar (232 psi)).

NOTICE

Pressure difference too high between process and wastewater system or if rinse connections are not properly connected.

Damage to seals

- ▶ Close rinse connections.
- ▶ Pipe-fit rinse connections.
- ▶ Use sealing water function.

Assignment of rinse connections

In the standard and immersion chamber version, the inlet and outlet of the service chamber are fixed. The outlet of the service chamber is located under the leakage hole. The leakage hole is sealed with an M5 screw.

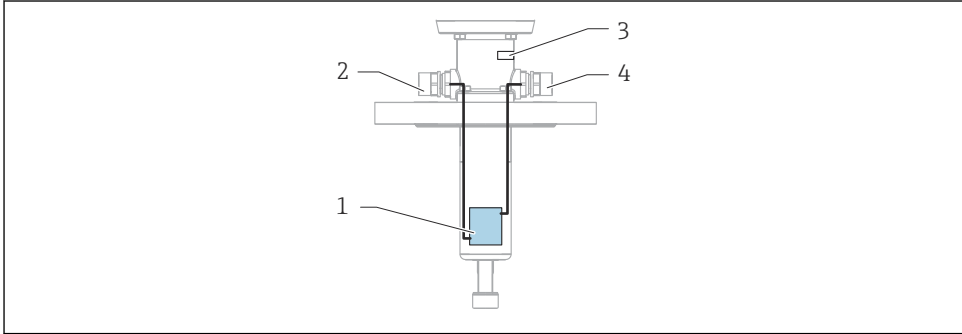

A0029621

 19 Connection of service chamber in the immersion chamber version

- 1 Service chamber
- 2 Service chamber inlet, IN
- 3 Leakage hole
- 4 Service chamber outlet, OUT

Leakage hole, M5 thread, optional connection must be supplied by customer

Used for visual inspection.

If medium leaks out:

1. Switch off the process
2. Replace the seals

Assembly connection

NOTICE

There is a connection between the process and the rinse chamber during insertion/retraction.

This can result in contamination or deposit buildup.

- ▶ Rinse/clean the assembly regularly.

NOTICE

Solids, deposits and/or sedimentation in the process medium can result in increased wear

Increased wear of the seal

- ▶ Rinse/clean the assembly regularly
- ▶ Check the sealing system regularly and perform maintenance when necessary.
- ▶ Use an automatic cleaning system

NOTICE**Connection between the process and service chamber during insertion/retraction**

Medium escaping during insertion/retraction. Service chamber is pressurized.

- ▶ To ensure controlled draining, connect the outlet of the rinse chamber to the drain.
- ▶ Release the pressure before performing maintenance tasks.
- ▶ Check the sealing system to ensure it is intact.

Assembly connection up to PN8*Delivery*

Rinse connections vary depending on the connection selected (G $\frac{1}{4}$ ", NPT $\frac{1}{4}$ " or Swagelok; Alloy C22 or stainless steel VA).

NOTICE

If the pressure compensation between the process pressure and the environment occurs too quickly, it can cause damage to the process seals when the assembly is inserted/retracted.

- ▶ Use versions that are suitable for process pressures up to 16 bar. These are fitted with a pressure retarder.

Connections	Thread	Delivery
Rinse connection outlet	G $\frac{1}{4}$ ", female thread	Mounted
Rinse connection inlet	G $\frac{1}{4}$ ", female thread	Mounted

Assembly connection PN16*Delivery*

Rinse connections vary depending on the connection selected (G $\frac{1}{4}$ ", NPT $\frac{1}{4}$ " or Swagelok)

Connections	Thread	Delivery
Dummy plug	M16, male thread	Mounted
Pressure retarder	M16, male thread to M16 female thread	Mounted
Rinse connection outlet	G $\frac{1}{4}$ " or NPT 1/4", female thread, or pipe connection	Mounted on pressure retarder
Rinse connection inlet	G $\frac{1}{4}$ " or NPT 1/4", female thread, or pipe connection	Included

Changing the dummy plug/rinse connection inlet

If an (automatic) cleaning or calibration system is used, the dummy plug must be replaced with the accompanying rinse connection inlet. The inlet and outlet must be fully connected.

1.

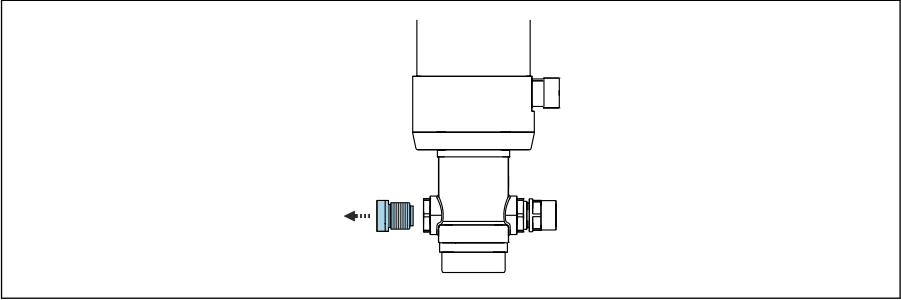

A0043258

Remove the dummy plug.

2. Replace the flat seal with the O-ring.

3.

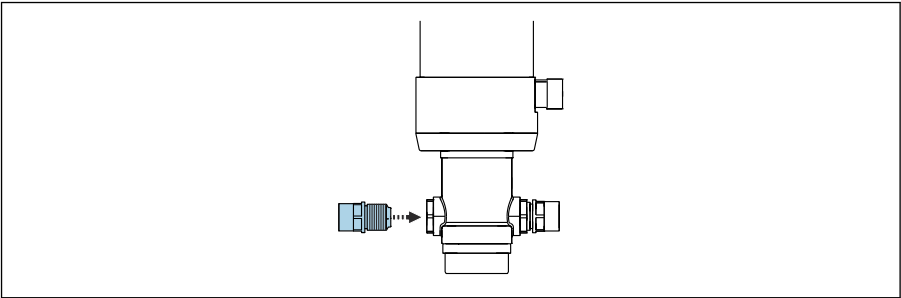

A0047539

Screw in the rinse connection inlet.

Connecting the cleaning unit

Assembly as-delivered state, PN16 with dummy plug and pressure retarder.

1. Replace the dummy plug with the rinse connection inlet. →  28

2.

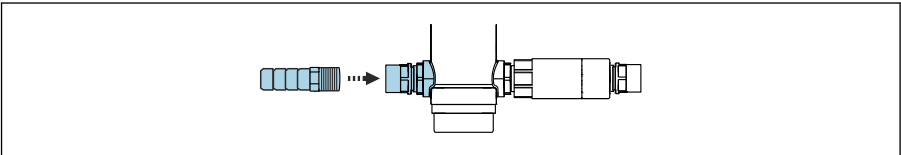

A0043236

Mount the connection for the rinse medium supply line (available to order as an accessory) on the rinse connection inlet.

3.

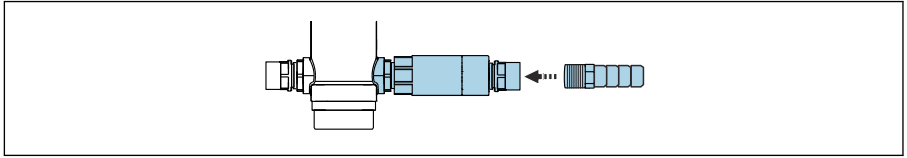

A0043237

Connect the rinse connection outlet (available to order as an accessory) to a drain line.

Complete seal PN8 and PN16

Complete seal with pressure retarder and ball valve

The complete seal with the pressure retarder and ball valve is only provided in the PN16 version. The pressure retarder must be mounted for this purpose. The ball valve can be ordered as an accessory (sealing kit).

The sealing kit only provided in connection with the rinse connection inlet G1/4". Version only available in stainless steel.

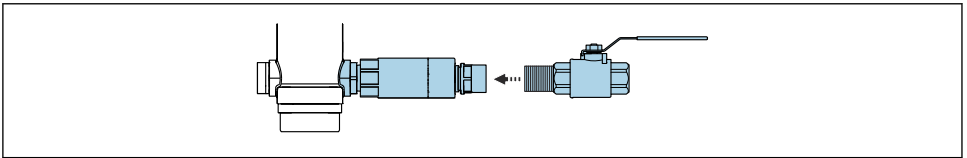

A0043406

Not suitable for media that tend to cake, form deposits or sediment, or contain solids.

- Screw the ball valve onto the rinse connection outlet of the pressure retarder.

Complete seal with extension and ball valve

The complete seal with the extension and ball valve is only provided in the PN8 version. The extension and ball valve can be ordered as an accessory. The extension is only necessary for the flange process connection. The ball valve and extension can be ordered as an accessory (sealing kit).

Not suitable for media that tend to cake, form deposits or sediment, or contain solids.

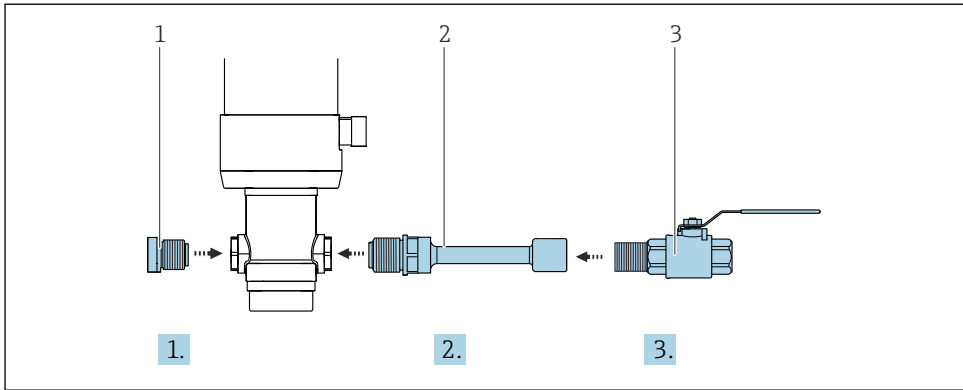

A0043341

1. Seal the rinse connection inlet with the dummy plug (1).
2. In the case of flange versions, screw the extension (2) into the rinse connection outlet.
3. Screw the ball valve (3) onto the rinse connection outlet or the extension.

Connecting the limit position switches

With limit position detection, you can notify a system located downstream (transmitter, switching amplifier, output interface terminal) whether the assembly is in the measuring or service position (in the case of manual drive, only the measuring position is queried).

The limit position switches must be connected to output interface terminals (can be ordered as accessories for the non-hazardous area) to enable power supply.

The assembly can be ordered directly with limit position detection, or it can be retrofitted at a later stage. The cable for the limit position switches must be ordered as an accessory.

Feedback devices

The feedback devices are intrinsically safe. The approval for the feedback devices is no longer valid if they are not installed or connected correctly.

1. Ensure full compliance with manufacturer documentation.
2. Connect the feedback devices in accordance with the relevant instructions.

Switching element function:	NAMUR NC contact (inductive)
Switching distance:	1.5 mm (0.06 in)
Nominal voltage:	8 V DC
Switching frequency:	0 to 5000 Hz
Housing material:	Stainless steel

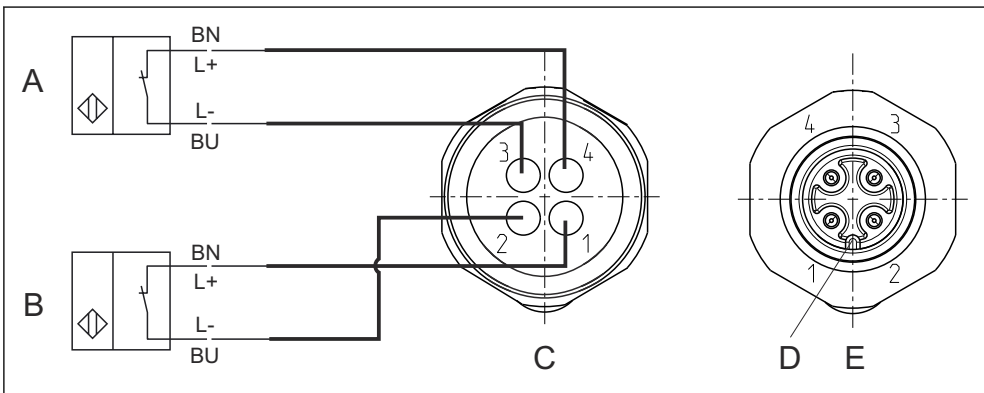

A0017831

☑ 20 Inductive limit position switches, internal cabling in the blue protective ring

- A Limit position switch, service position
- B Limit position switch, measuring position
- C Connector, M12, solder side (inside of assembly)
- D Coding
- E Connector, pin side (outside of assembly)

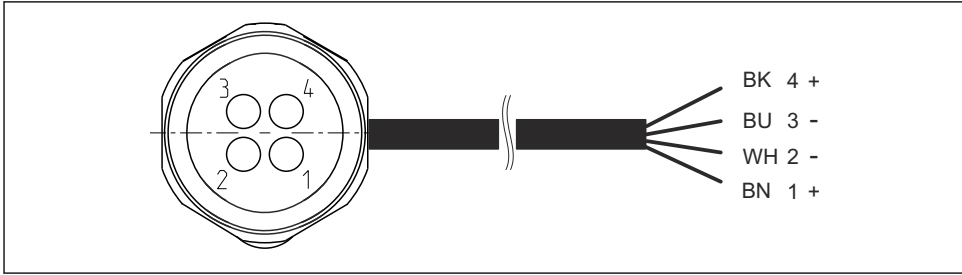

A0022.163

- 21 *Connecting cable for limit position switch on transmitter, switching amplifier, output interface terminal etc.*

- 1 *Measuring position*
- 2 *Measuring position*
- 3 *Service position*
- 4 *Service position*

i Only pins 1 and 2 are assigned for manually activated assemblies with one switch (measuring position).

i If the feedback devices are operated with a 24 V DC power supply, e.g. at Liquiline CM442/CM444/CM448, NAMUR terminals must be used. NAMUR terminal (8 V DC) for the non-hazardous area available as an accessory → 70. The NAMUR terminal must have its own power supply and cannot be powered by a current output of the CM44.

i For versions CPA87x-AB* for use in hazardous areas, the enclosed manufacturer's declaration and the operating instructions for the installed Pepperl+Fuchs NJ1.5-6.5-15-N-Y180094 feedback devices must be observed.

Signal table for limit position switches

Position of assembly	Limit position switch, measuring position	Limit position switch, service position
Measuring	Active LOW (≥ 3 mA)	Active LOW (≥ 3 mA)
Service	Active HIGH (≤ 1 mA)	Active HIGH (≤ 1 mA)

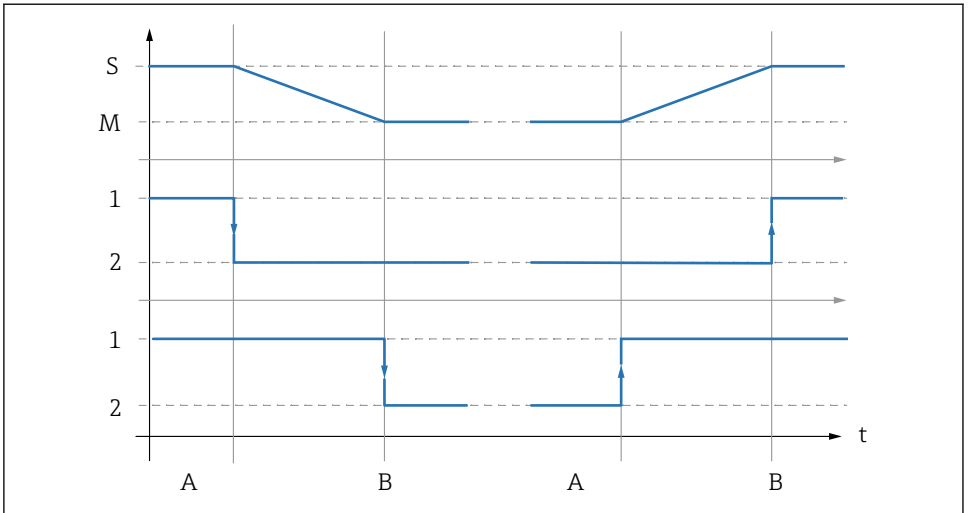

A0039144

22 Description of switching function

S Service

M Measuring

1 High

2 Low

A Movement starts

B Limit position reached

5.2.2 Sensor installation

Preparing the sensor and assembly

NOTICE

Danger of medium penetrating if a defective sensor is installed.

- ▶ Inspect the sensor and use a new, intact sensor if necessary.

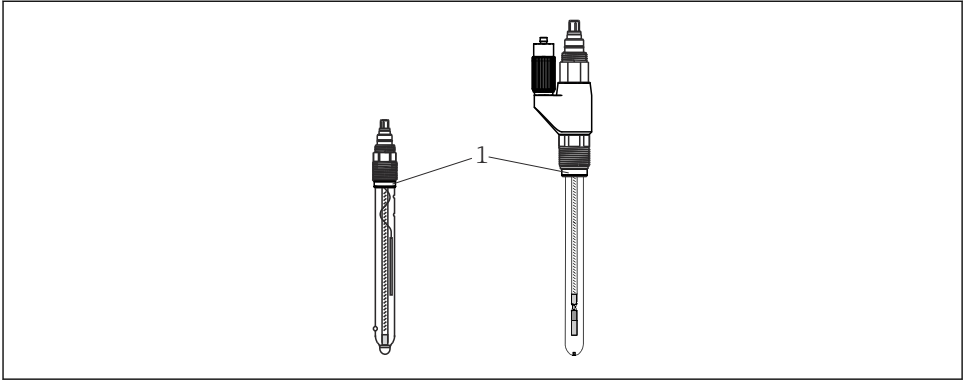

A0030154

☐ 23 Sensor installation

1 Thrust collar with O-ring

1. Remove the protective cap from the sensor. Make sure that the O-ring and thrust collar (→ ☐ 23, item 1) are provided.
2. To aid installation, immerse the sensor shaft in water.
3. Move the assembly to the service position.

Installing and removing sensors

⚠ WARNING

Risk resulting from temperature, pressure and chemical composition!

- ▶ Establish pressure compensation in the service chamber.
- ▶ Before removing, clean and rinse the sensor adequately in the rinse chamber.
- ▶ Check process seals. (There can be no leakage of medium from the rinse chamber in limit position when rinsing is disabled)

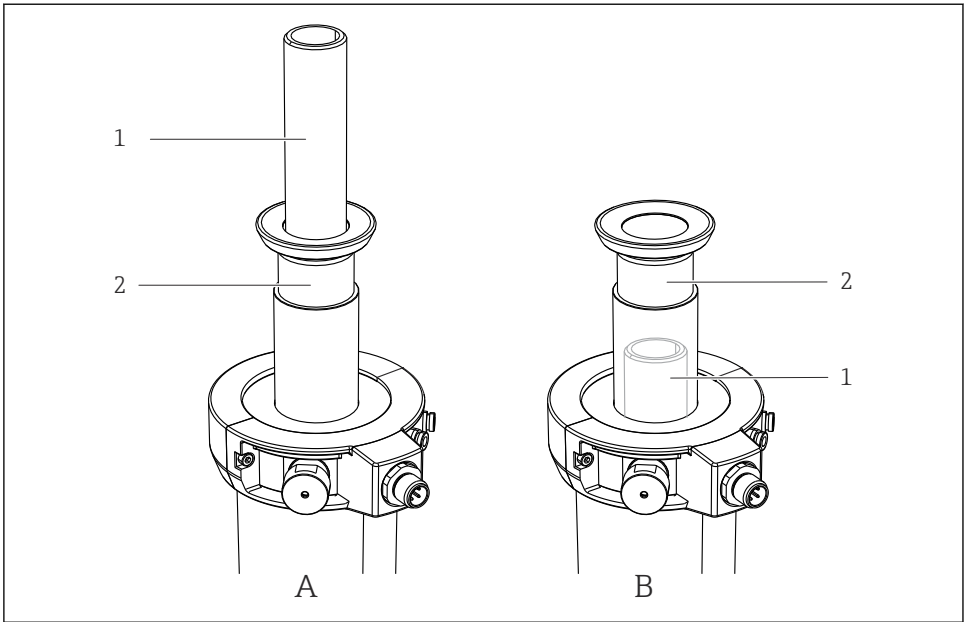

A0030155

▣ 24 Sensor installation options

1 Sensor adapter

2 Retraction tube

A Sensor adapter is on top of the retraction tube

B Sensor adapter is below the retraction tube (not visible)

Depending on the assembly version, the sensor adapter is visible (, item A) or is positioned within the retraction tube and is not visible (item B). As a result, the procedures for installing and removing the sensors differ as follows:

Installing and removing sensors if the sensor adapter is visible (item A)

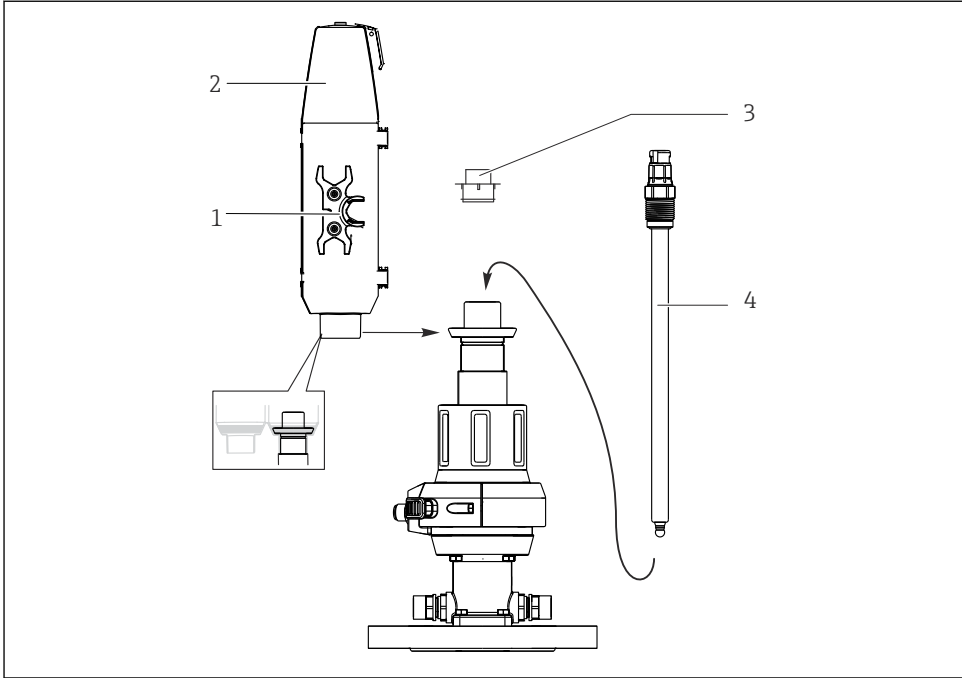

A0030156

25 Sensor installation

- 1 Open-ended wrench (AF 17/19 mm)
- 2 Protective cover
- 3 Dummy plug
- 4 Sensor

i Gel and KCl sensors can be installed in this version.

Install the sensor as follows:

1. Remove the protective cover (→ 25, item 2) (this is only possible if the assembly is in service position).
2. Remove the yellow dummy plug (item 3).
3. Use the open-ended wrench (item 1) to screw in the sensor (item 4) in place of the dummy plug and hand-tighten (3 Nm (2.2 lbf ft)).
4. Attach the open-ended wrench back into the protective cover.

5. Mount the protective cover on the assembly. When doing so, guide the measuring cable through the cable run (top of protective cover).

i Always install the protective cover before moving the assembly to measuring position. The protective cover cannot be removed in measuring position. This prevents the sensor from being removed.

Installing and removing sensors if the sensor adapter is not visible (item B)

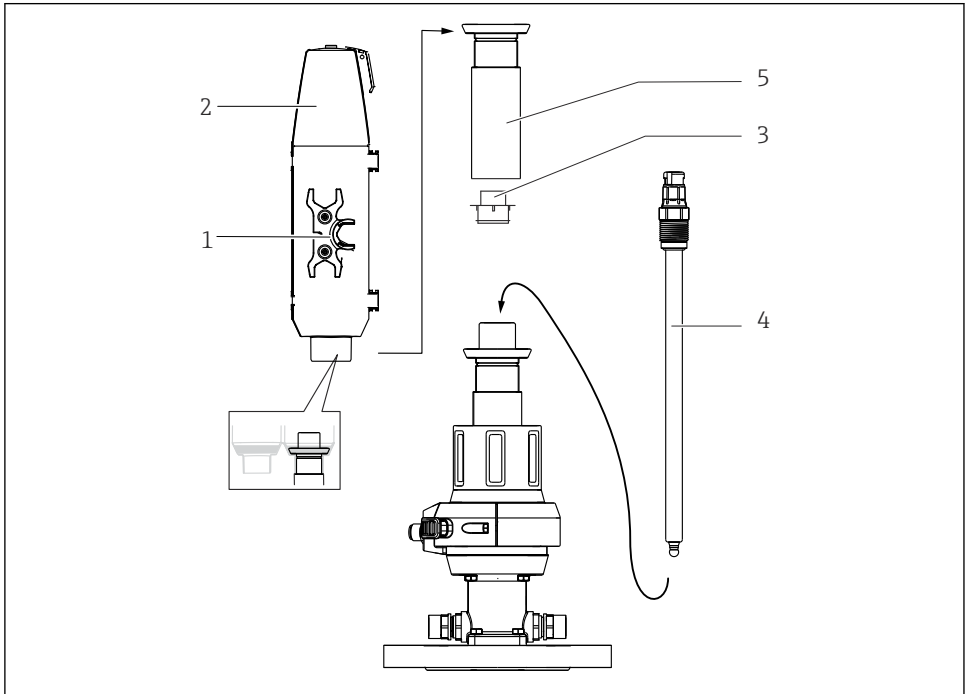

A0030157

26 Sensor installation

- 1 Socket wrench (AF 17/19 mm)
- 2 Protective cover
- 3 Dummy plug (protective cap)
- 4 Sensor
- 5 Retraction tube

i Gel sensors can be installed in this version. To install KCl sensors, you will need a "Gel - KCl adapter".

Install the sensor as follows:

1. Remove the protective cover (→ **26**, item 2) (this is only possible if the assembly is in service position).

2. Unscrew the retraction tube (item 5) in a counterclockwise direction.
3. Remove the yellow dummy plug (item 3).
4. Use the open-ended wrench (item 1) to screw in the sensor (item 4) in place of the dummy plug and hand-tighten (3 Nm (2.2 lbf ft)).
5. Screw in the retraction tube again.
6. Attach the open-ended wrench back into the protective cover.
7. Mount the protective cover on the assembly. When doing so, guide the measuring cable through the cable run (top of protective cover).

 Always install the protective cover before moving the assembly to measuring position. The protective cover cannot be removed in measuring position. This prevents the sensor from being removed.

Installation of 360 mm gel and KCl sensors with the "Gel - KCl adapter"

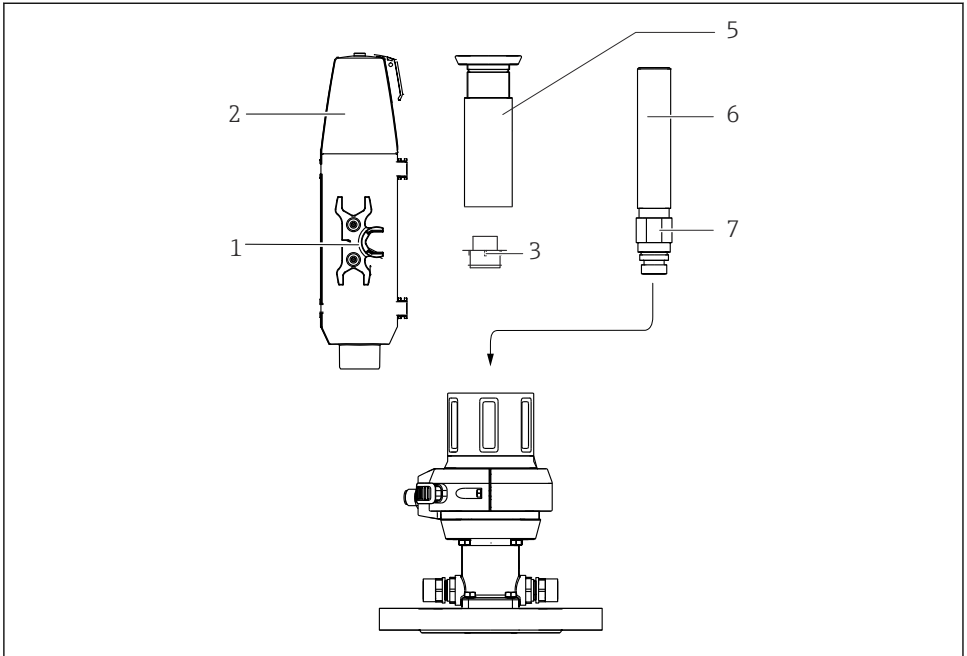

A0030158

🔧 27 Sensor installation, Part 1

- 1 Open-ended wrench (AF 17/19 mm)
- 2 Protective cover
- 3 Dummy plug (protective cap)
- 5 Retraction tube
- 6 Gel - KCl adapter
- 7 Lock nut



Gel and KCl sensors can be installed in this version.

NOTICE

The protective cover cannot be removed in measuring position. This prevents the sensor from being removed.

- ▶ Always install the protective cover before moving the assembly to measuring position.
- ▶ There is an opening prepared at the top of the cover which can be broken out if necessary to feed the hose through

Install the sensor as follows:

1. Remove the protective cover (→ 🔧 27, item 2) (this is only possible if the assembly is in service position).

2. Unscrew the retraction tube (item 5) (in a counterclockwise direction).
3. Turn the lock nut (item 7) on the "Gel - KCl adapter" (item 6) as far as it will go in an upward direction.
4. Remove the yellow dummy plug (item 3).
5. Screw in the "Gel - KCl adapter" (item 6) in place of the dummy plug and hand-tighten (3 Nm (2.2 lbf ft)).
6. Hand-tighten the lock nut in a clockwise direction, and then use an open-ended wrench (AF 24 mm) to tighten it by $\frac{1}{4}$ turn.
7. Screw in the retraction tube again.
8. Use the open-ended wrench (item 1) to screw in the sensor (\rightarrow  28, item 4) and hand-tighten (3 Nm (2.2 lbf ft)).
9. Attach the open-ended wrench back into the protective cover.
10. Mount the protective cover on the assembly. When doing so, guide the measuring cable through the cable run (top of protective cover).

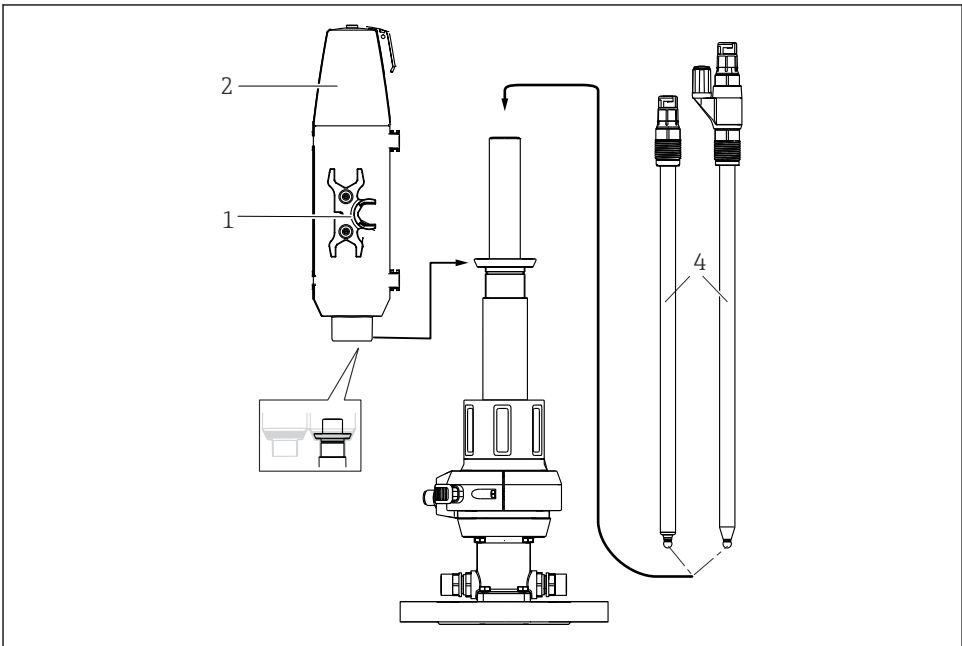

A0030159

 28 Sensor installation, Part 2

- 1 Open-ended wrench
 2 Protective cover
 4 360 mm gel or KCl sensor

5.3 Post-installation check

Put the sensor into operation only if you can answer "yes" to the following questions:

- Are the sensor and cable undamaged?
- Is the orientation correct?
- Is the sensor installed in an assembly and not suspended from the cable?

5.3.1 Checking that the sealing system is intact

Check the seals after mounting or removing the sensor, and when maintenance work is carried out at regular intervals.

1. Move the assembly to the service position
2. If provided, open the ball valve of the service chamber outlet
 - ↳ It is normal for a slight amount of medium to escape (connection between the service chamber and process during insertion/retraction).
3. If provided, rinse the service chamber/sensor.
4. Observe the outlet. No more medium should escape after a short period of time.
5. If medium continues to escape, the sealing system is damaged; take the measuring point out of service and perform maintenance on the assembly.

6 Commissioning

6.1 Preliminaries

Before commissioning, ensure that:

- all seals are correctly seated (on the assembly and on the process connection).
- the sensor is correctly installed and connected.
- the water connection at the rinse connections is correct (if present) or the rinse connections are sealed.

WARNING

Risk of injury from high pressure, high temperature or chemical hazards if process medium escapes.

- ▶ Check the connections to ensure they are sealed tightly.

WARNING

Process medium may escape during insertion/retraction of the assembly.

- ▶ Check that the process seal is intact.
- ▶ Pipe-fit the rinse chamber outlet accordingly.
- ▶ Seal the rinse connections with dummy plugs.



Note that when the assembly is inserted/retracted, an open connection exists for a short period between the process and service chamber.

7 Operation

7.1 Adapting the assembly to the process conditions

CAUTION

Due to the operating principle, there is a connection between the process and the service chamber. The service chamber can be pressurized as a result.

Process medium may escape during insertion/retraction.

- ▶ Check that the process seal is intact.
- ▶ Pipe-fit the rinse chamber outlet accordingly.
- ▶ Seal the rinse connections with dummy plugs.

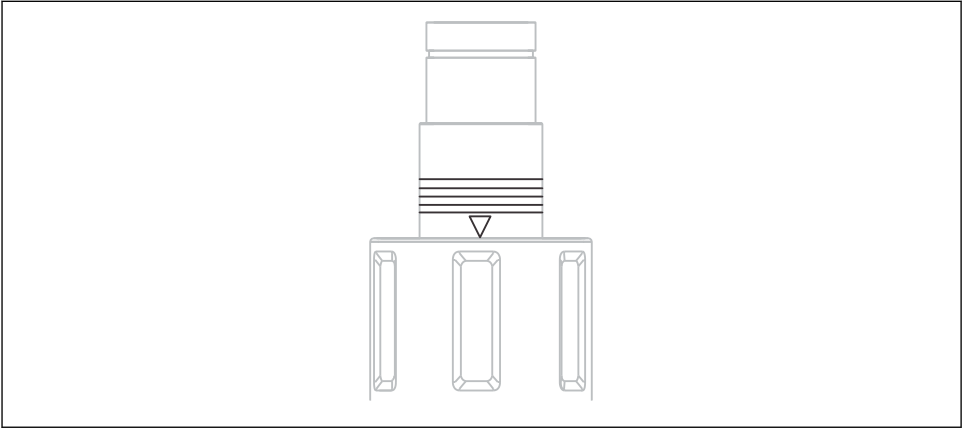

A0023307

 29 Position markings (service position)

 The assembly with pneumatic drive does not have any operating elements.

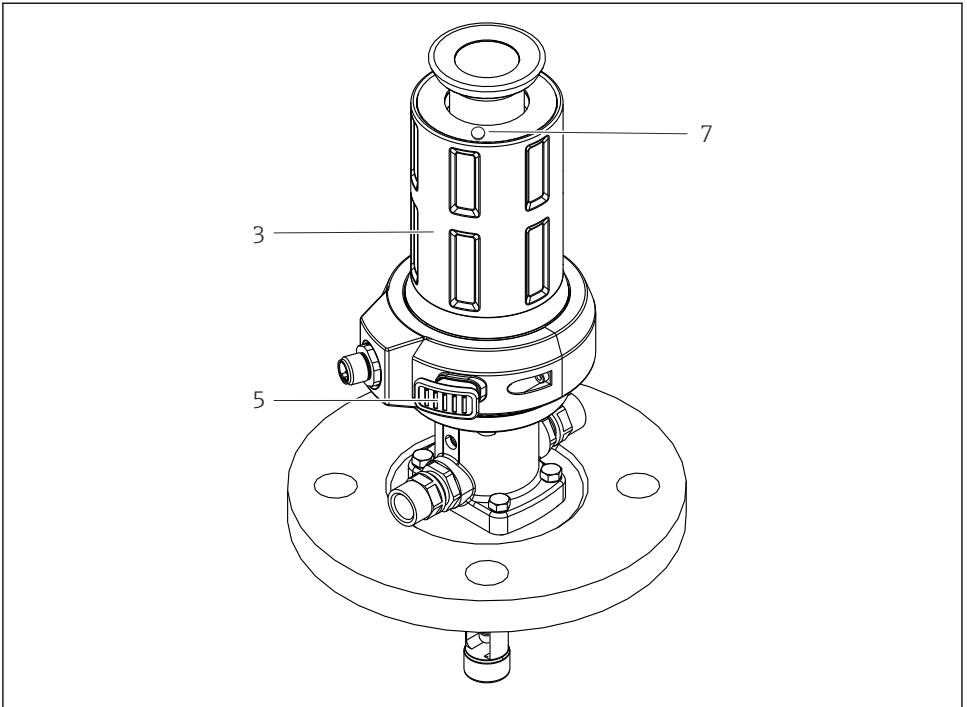

A0030305

30 Assembly with manual operation, operating elements

- 3 Manual drive
- 5 Unlocking button (measuring position)
- 7 Unlocking button (service position)

7.1.1 Manual operation

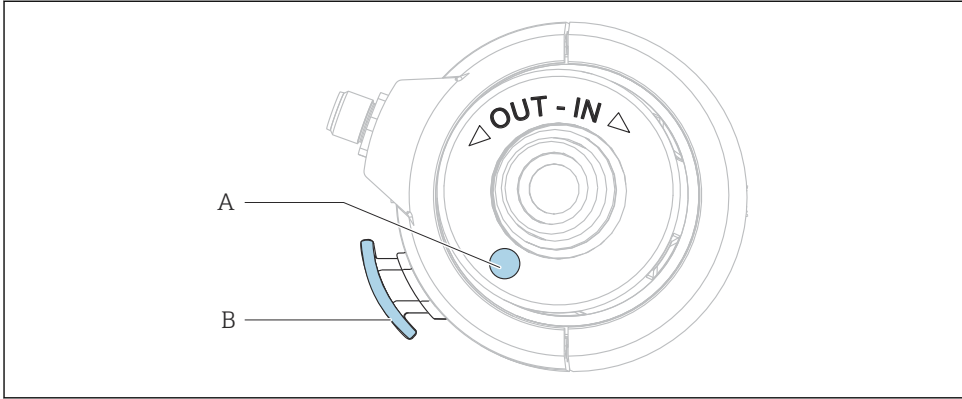

A0030330

31 Direction of rotation

- A Unlocking button (service position)
 B Unlocking button (measuring position)

Moving the assembly from the service position to the measuring position

The assembly can only be inserted/retracted if a sensor is installed.

1. Press the unlocking button (A).
2. With the unlocking button (A) pressed during the first quarter turn, rotate the drive in a clockwise direction so that the sensor holder enters the process (this is possible only if a sensor is installed). You can release the button for any continued movement.
3. Rotate the drive until the lock engages.

Moving the assembly from the measuring position to the service position

1. Press the unlocking button (B).
2. With the unlocking button (B) pressed during the first quarter turn, rotate the drive in a counterclockwise direction until the stop (service position).
3. Perform the necessary service work.

7.1.2 Pneumatic operation

The assembly can only be inserted/retracted if a sensor is installed.

Operation of the pneumatic version depends on the controller in question. Consult the controller manual for instructions.

Use a pneumatic pilot valve (4/2-way or 5/2-way) to insert/retract the assembly.

- ▶ Connect the two inputs.
 - ↳ If only one input is connected, the piston is blocked as the sensor guide moves before the limit position lock is disabled.

Inserting/retracting the assembly if the compressed air supply fails

⚠ CAUTION

Risk of injury due to high medium pressure

- ▶ Depressurize the system.

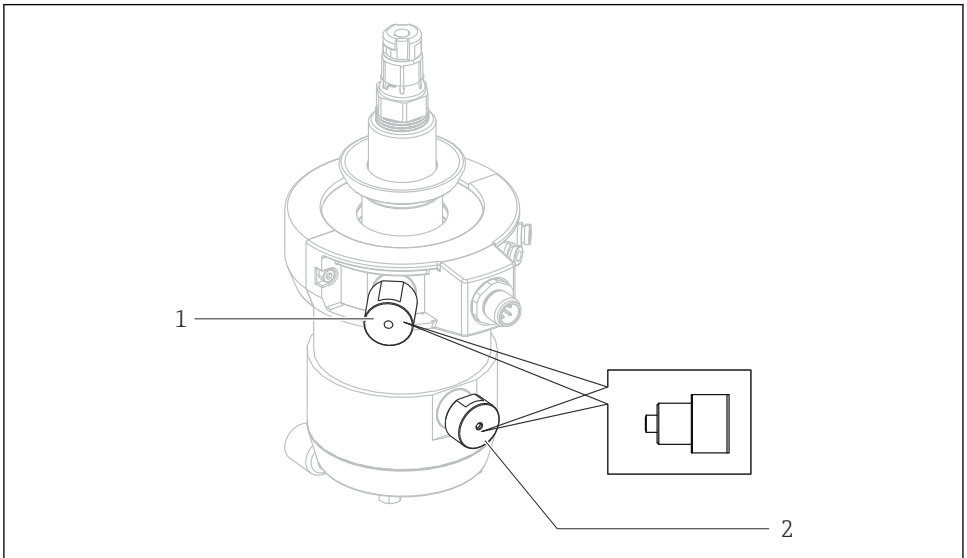

A0030306

32 Failure of compressed air supply

- 1 Limit position lock for service position
- 2 Limit position lock for measuring position

If the compressed air supply fails, you can still move the assembly manually. Proceed as follows here:

1. Use an open-ended wrench (AF 17 mm (0.67 in)) to unscrew both limit position locks (items 1 and 2).
2. Move the assembly to the desired position manually (only possible with sensor installed).
3. Screw the limit position lock back in.

8 Maintenance

WARNING

Risk of injury if medium escapes

- ▶ Before each maintenance task, ensure that the process pipe is empty and rinsed.
- ▶ Move the assembly to the service position.
- ▶ The assembly may contain residual medium; rinse thoroughly before commencing work.

 The assembly drive is maintenance-free. It is not possible to carry out maintenance or repair work on the drive.

8.1 Maintenance schedule

 A maintenance log is recommended to adapt to the correct maintenance intervals.

 The specified intervals serve as a guide. For harsh process or ambient conditions, it is recommended that the interval be shortened accordingly. Cleaning intervals for the sensor and assembly are dependent on the medium.

 Following cleaning or replacement, apply a generous layer of Klüber XPC0003-V+R8 grease to the seals.

Interval	Maintenance measures
During initial commissioning / when putting back into service after maintenance	<ul style="list-style-type: none"> ▶ Perform initial inspection. ▶ Check that all connections are sealed tightly. ▶ Check the locking mechanism (no movement without a sensor). ▶ Check the locking bolt (no movement without compressed air).
Regularly	<p>Visual inspection:</p> <ul style="list-style-type: none"> ▶ Check movement of the assembly. ▶ Clean and lubricate the retraction tube as needed, depending on the level of dirt. ▶ Check that all connections are sealed tightly. <p>Check for tightness:</p> <ul style="list-style-type: none"> ▪ Rinse lines ▪ Process connection ▪ Compressed air hoses (pneumatic drive). <p>Clean the process seal using the sealing water function:</p> <ul style="list-style-type: none"> ▶ Close the rinse chamber outlet. ▶ Rinse in the process in order to clean the seals.
Monthly or after 500 strokes (whichever comes first)	<ul style="list-style-type: none"> ▶ Check that the process seal is intact. ▶ Replace the seals if medium is escaping. ▶ Check the leakage hole. Remove the screw to do this. <p>Does medium escape from the leakage hole when the assembly is moving? This can be an indicator of faulty inner O-rings in the service chamber.</p> <ol style="list-style-type: none"> 1. Check the leakage hole of the service chamber. 2. Clean the assembly thoroughly. 3. Replace seals in contact with the medium.

Interval	Maintenance measures
	<ol style="list-style-type: none"> 1. Inspect the sensor. 2. Disassemble the sensor. 3. Check the sensor for deposits. 4. If deposits are present, check cleaning cycle (cleaning agents, temperature, duration, flow volume). <p>When process pressure is applied and cleaning disabled, there should be no discharge of medium from the assembly's rinse chamber outlet.</p> <ul style="list-style-type: none"> ▶ Check for defective process seal(s).
<p>Biannually or after 5000 strokes (whichever comes first)</p>	<ul style="list-style-type: none"> ▶ Clean the assembly thoroughly. ▶ Remove the residual medium. ▶ Replace all seals in contact with the medium. ▶ Clean the retraction tube. ▶ Lubricate the retraction tube. <ol style="list-style-type: none"> 1. Check mobility of retraction protection. 2. Remove the sensor. <ul style="list-style-type: none"> ↳ The contact surface of the sensor in the assembly is spring-loaded and must be free to move. <p>Possible cause of failure: contamination inside the drive, e.g. caused by a broken sensor.</p>

8.2 Maintenance work

8.2.1 Cleaning agent



WARNING

Organic solvents containing halogens

Limited evidence of carcinogenicity! Dangerous for the environment with long-term effects!

- ▶ Do not use organic solvents that contain halogens.



WARNING

Thiocarbamide

Harmful if swallowed! Limited evidence of carcinogenicity! Possible risk of harm to the unborn child! Dangerous for the environment with long-term effects!

- ▶ Wear protective goggles, protective gloves and appropriate protective clothing.
- ▶ Avoid all contact with the eyes, mouth and skin.
- ▶ Avoid discharge into the environment.

The most common types of contamination and the cleaning agents used in each case are shown in the following table.



Pay attention to the material compatibility with the materials to be cleaned.

Type of contamination	Cleaning agent
Greases and oils	Hot water or tempered (alkaline) agents containing surfactants or water-soluble organic solvents (e.g. ethanol)
Limescale deposits, metal hydroxide buildup, lyophobic biological buildup	Approx. 3% hydrochloric acid
Sulfide deposits	Mixture of 3% hydrochloric acid and thiocarbamide (commercially available)
Protein buildup	Mixture of 3% hydrochloric acid and pepsin (commercially available)
Fibers, suspended substances	Pressurized water, possibly surface-active agents
Light biological buildup	Pressurized water

- ▶ Choose a cleaning agent to suit the degree and type of soiling.

8.2.2 Cleaning the assembly

WARNING

Risk of injury if medium escapes

- ▶ Before each maintenance task, ensure that the process pipe is empty and rinsed.
- ▶ Move the assembly to the service position.
- ▶ The assembly may contain residual medium; rinse thoroughly before commencing work.

WARNING

Loss of proper functionality.



- ▶ Do not open or disassemble the drive.
- ▶ Only the O-ring on the base of the retraction pipe should be renewed during maintenance.
- ▶ Clean and lubricate the retraction pipe regularly.

For stable and safe measurements:

1. Clean the assembly and sensor regularly. The frequency and intensity of the cleaning depend on the medium.
2. Use isopropyl alcohol to clean metal parts, but not the O-rings.

Manually operated assembly

All parts in contact with the medium, such as the sensor and the sensor guide, must be cleaned regularly.

1. Remove the sensor in the logically reverse sequence to the mounting procedure.
→  34
2. Remove light dirt and fouling with suitable cleaning solutions. (→  47
3. Remove heavy soiling using a soft brush and a suitable cleaning agent.

4. For very persistent dirt, soak the parts in a cleaning solution. Then clean the parts with a brush.



A typical example of a cleaning interval would be 6 months in the case of drinking water.

Pneumatically controlled assembly

Regular, pneumatically controlled cleaning is recommended using the rinse water connection and the appropriate equipment.

1. Take apart parts that are in contact with the medium.
2. Clean parts that are in contact with the medium.
3. Clean metal parts with isopropyl alcohol. Do not use isopropyl alcohol to clean the O-rings.

8.2.3 Cleaning the sensor

→ Documentation of the connected sensor

1. Always clean ORP electrodes mechanically and with water.
2. Do not use chemical cleaning agents.
 - ↳ Such cleaning agents cause a potential to build up at the electrode which takes a few hours to dissipate. The potential causes errors in the measurement.
3. Do not use abrasive cleaning agents.
 - ↳ These can cause irreparable damage to the sensor.
4. Perform another calibration following cleaning if necessary.

Clean the sensor:

- Before every calibration
- Regularly during operation
- Before returning it for repairs

You can remove the sensor and clean it manually, or you can clean it in automatic mode ¹⁾ using the rinse water connection.

In event of minor deposit build-up:

1. Place the sensor in warm water.
2. Clean the sensor with a mild dishwashing detergent.

8.2.4 Replacing seals

To replace the seals in the assembly, you must interrupt the process and remove the assembly completely.

1) only if the assembly is fitted out accordingly

⚠ CAUTION**Risk of injury due to residual medium and elevated temperatures**

- ▶ When handling parts that are in contact with the medium, protect against residual medium and elevated temperatures. Wear protective goggles and safety gloves.

⚠ CAUTION**Increased wear of dynamically loaded seals**

- ▶ Apply sufficient grease to the seals, e.g. Klüber Paraliq GTE 703.
- ▶ Reduce maintenance cycles.
- ▶ Clean the assembly prior to replacing seals. (→ 📄 48)

Preparation:

1. Interrupt the process. Pay attention to residual medium, residual pressure as well as elevated temperatures.
2. Move the assembly to service position.
3. Completely detach the assembly from the process connection.
4. Clean the assembly. (→ 📄 48)

Checking that the sealing system is intact

Check the seals after mounting or removing the sensor, and when maintenance work is carried out at regular intervals.

1. Move the assembly to the service position
2. If provided, open the ball valve of the service chamber outlet
 - ↳ It is normal for a slight amount of medium to escape (connection between the service chamber and process during insertion/retraction).
3. If provided, rinse the service chamber/sensor.
4. Observe the outlet. No more medium should escape after a short period of time.
5. If medium continues to escape, the sealing system is damaged; take the measuring point out of service and perform maintenance on the assembly.

Retraction tube

Seal replacement in the retraction tube

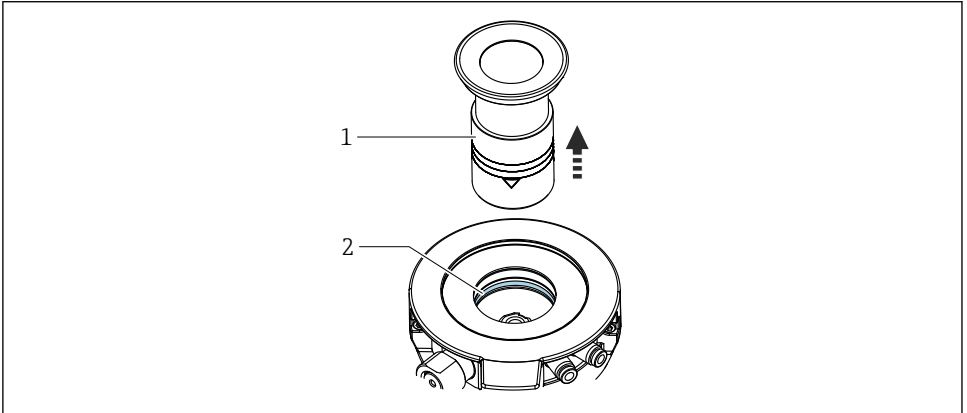

A005550

- 1 Retraction tube
2 O-ring

1. Unscrew the retraction tube (1) from the assembly.
2. In the pneumatic version, unscrew the automatic limit position locks with a combination wrench (AF 17).
3. Move the assembly to the measuring position manually (only possible with sensor installed or sensor dummy).
4. Use a suitable tool, e.g. a spark plug wrench, to press the protection pipe carefully downwards.
5. Remove the exposed O-ring (2) from the groove using an O-ring picker.
6. Clean the retraction tube (1) and apply a thin layer of grease (e.g., Klüber Paraliq GTE 703).
7. Grease the O-Ring and insert.
8. Mount the retraction tube (1) and, where applicable, the pneumatic limit position locks on the assembly.

Standard version

Seal replacement in the process connection

1.

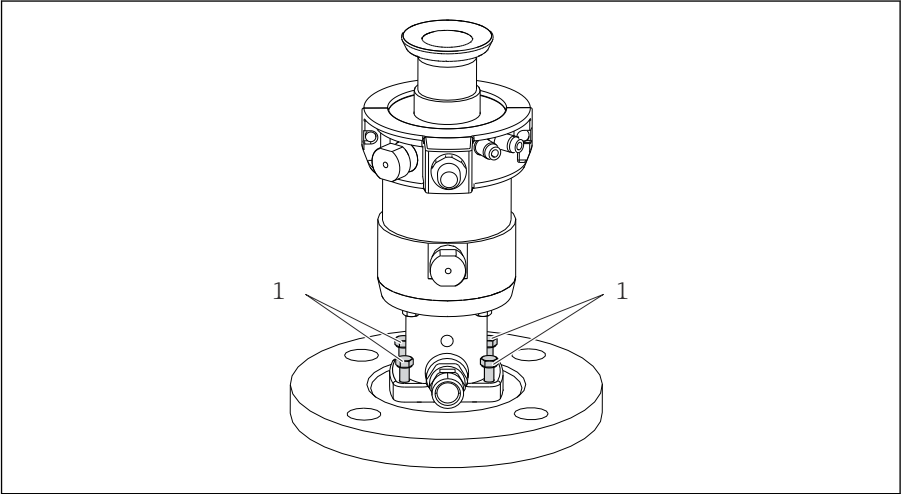

A0030290

 33 *Replacing seals, Part 1*

1 *Securing screws AF 8*

Release the four securing screws (item 1).

2.

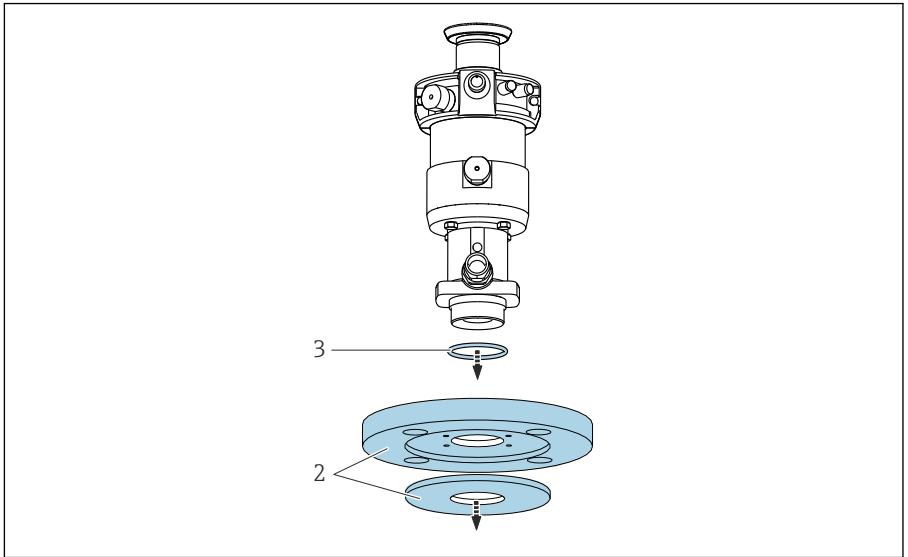

A0030291

34 Replacing seals, Part 2

2 Process connection

3 O-ring in process connection

Remove the process connection (item 2).

3. Remove the O-ring (item 3) from the process connection (gasket).
4. Apply a thin layer of grease to the new O-ring (e.g., Klüber Paraliq GTE 703).
5. Insert the O-ring into the process connection.

Seal replacement in the rinse connection

1.

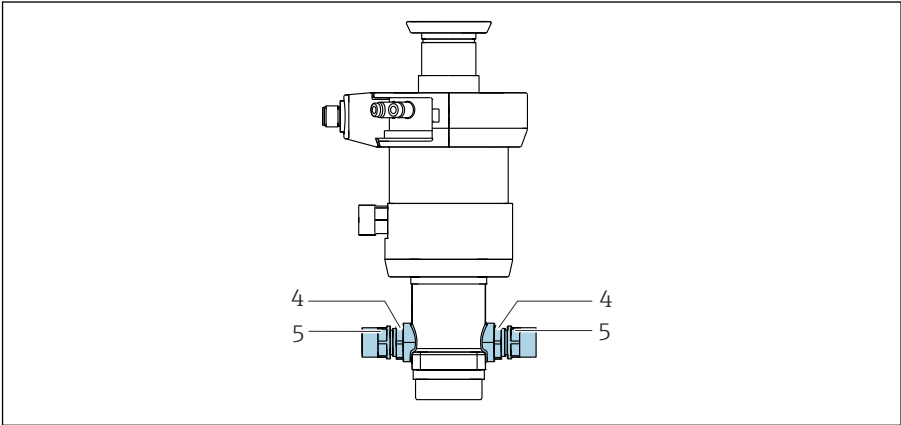

A0030292

35 Replacing seals, Part 3

4 Lock nut

5 Rinse connection adapter

Release the lock nuts (item 4) using an open-ended wrench or socket wrench (AF 19 mm, in protective cover).

2. Unscrew the two rinse connection adapters (item 5) using an open-ended wrench or socket wrench (AF 17 mm, in protective cover).

3.

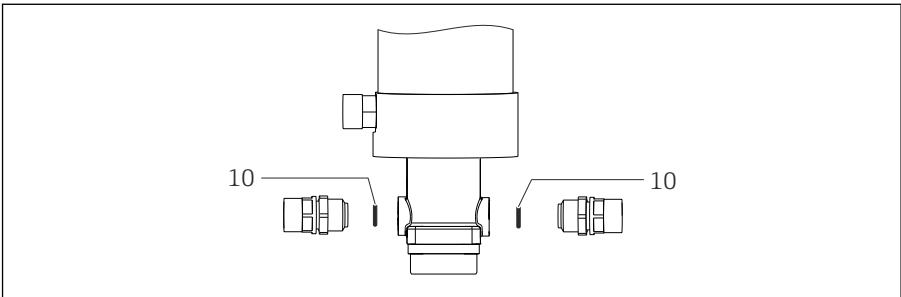

A0030315

36 Replacing seals, Part 3

10 O-rings, rinse connection adapter

Remove the O-rings indicated (item 10).

4. Apply a thin layer of grease (e.g., Klüber Paraliq GTE 703) to the new O-rings.
5. Insert the O-rings into the corresponding grooves.

Seal replacement in the support housing

1.

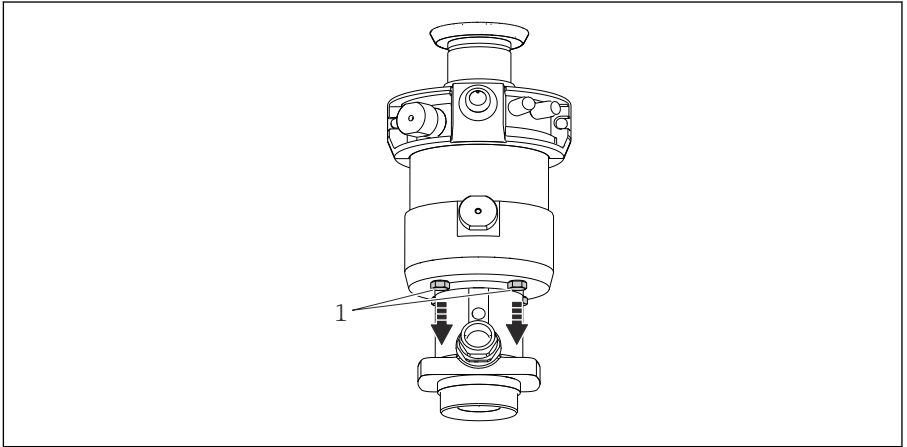

A0030310

▣ 37 *Replacing seals, Part 4*

1 *Securing screws AF 8*

Release the four securing screws (item 1).

2.

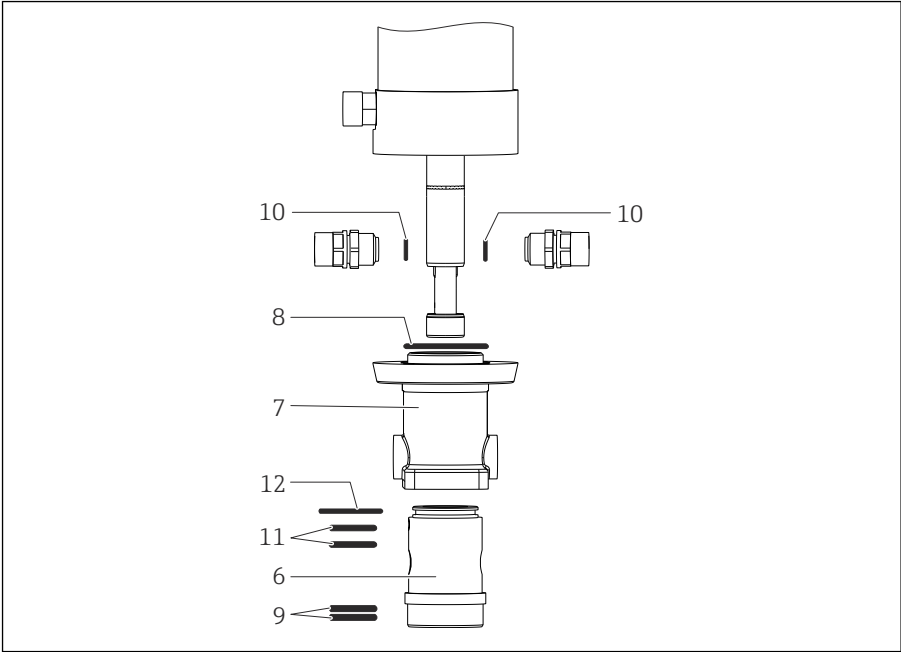

A0030293

38 Replacing all seals

- 6 Service chamber
- 7 Support housing
- 8 O-ring, support housing (pneumatic assembly only)
- 9 O-ring, bottom of service chamber (process seal)
- 10 O-ring, rinse connection adapter
- 11 O-ring, top of service chamber
- 12 O-ring, outer service chamber

Remove the support housing (item 7).

3. The rinse connection adapters must already have been removed. Pull the service chamber (item 6) out of the support housing.
4. Remove the O-rings indicated.
5. Apply a thin layer of grease (e.g., Klüber Paraliq GTE 703) to the new O-rings.
6. Insert the O-rings into the corresponding grooves.

Reassembly

Fit support housing and service chamber together

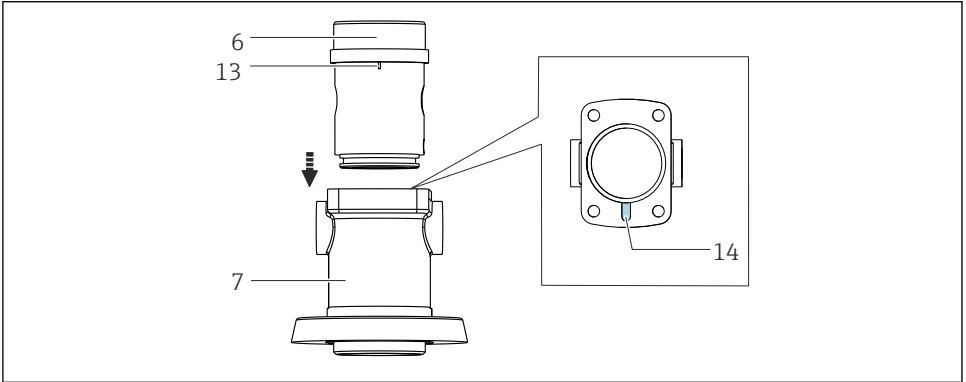

A0030343

39 Assembling the support housing

- 6 Service chamber
- 7 Support housing
- 13 Positioning pin
- 14 Positioning groove

1. Place the support housing (item 7) on a level surface.
 - ↳ The positioning groove (item 14) is visible from above.
2. Place the service chamber (item 6) on the support housing.
3. Slide the service chamber into the support housing.
4. Place the positioning pin (item 13) over the corresponding groove.
5. Push the service chamber into the groove.
6. Mount the process connection on the support housing.
7. Tighten the securing screws with a torque of 4 Nm.

Tighten the lock nut

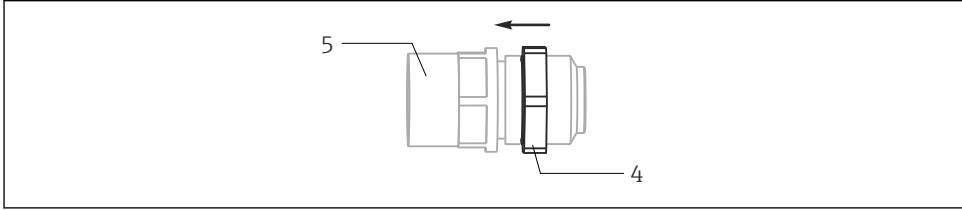

A0030344

40 Assembling the rinse connection

4 Lock nut AF19

5 Rinse connection adapter AF17

1. Turn the lock nut (item 4) on both of the rinse connection adapters (item 5) as far as possible in the direction of the arrow.
2. Insert the rinse connection adapters with O-rings into the support housing (open-ended wrench or socket wrench AF 17 mm).
3. Tighten the lock nut (AF 19 mm) in the opposite direction to the arrow.
4. Mount the support housing on the assembly. Pay attention to the positioning pin.
5. Tighten the securing screws with a torque of 4 Nm.

Test for leak-tightness

Use the plug to check that the assembly is sealed tightly:

1. Seal the rinse chamber outlet with the plug.
2. Apply pneumatic pressure to the rinse chamber inlet (max. 6 bar absolute pressure).
3. Hold the assembly under water as far as the rinse chamber. In so doing, do not submerge the drive in the water.
 - ↳ The test is successful if no air bubbles appear.

Immersion chamber version

Seal replacement in the process connection

1.

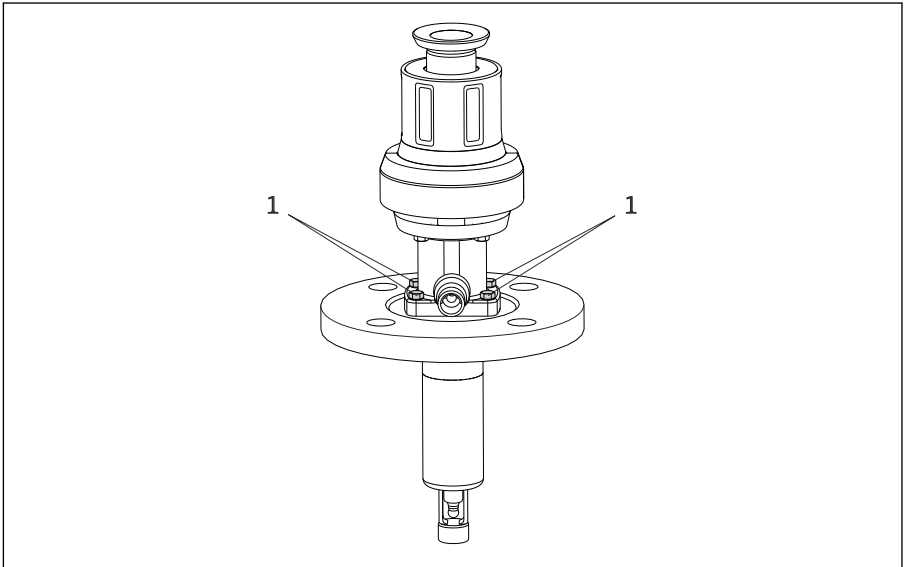

A0030294

41 Replacing seals, Part 1

Release the four securing screws (item 1).

2.

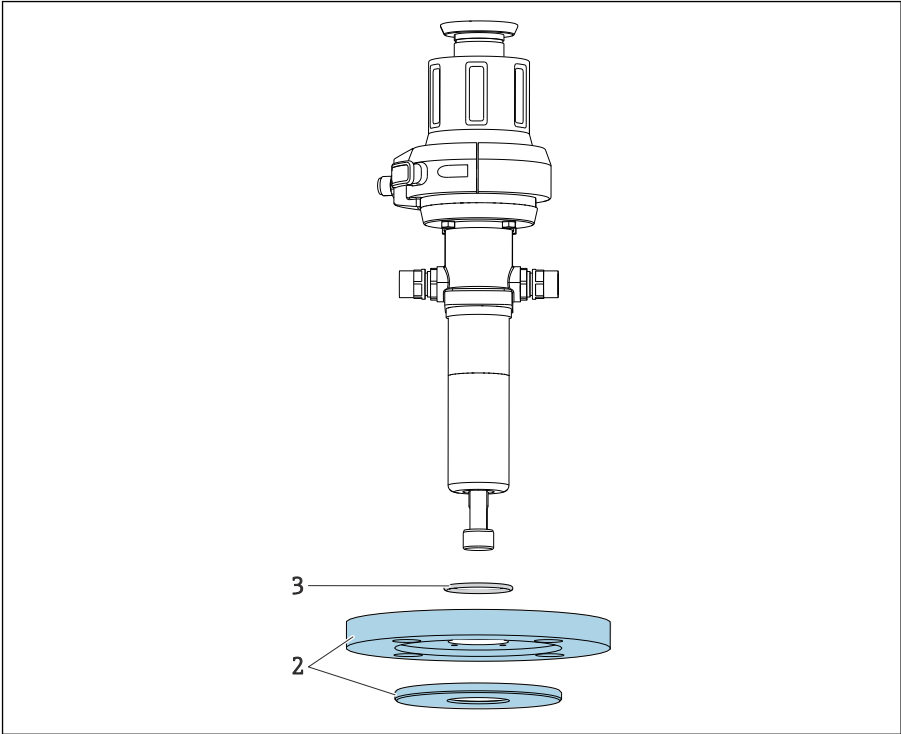

A0030295

42 Replacing seals, Part 2

2 Process connection

3 O-ring in process connection

Remove the service chamber (item 3) with the process connection (item 2).

3. Remove the O-ring (item 3) from the process connection (gasket).
4. Apply a thin layer of grease to the new O-ring (e.g., Klüber Paraliq GTE 703).
5. Insert the O-ring into the process connection.

Seal replacement in the rinse connection adapter

1.

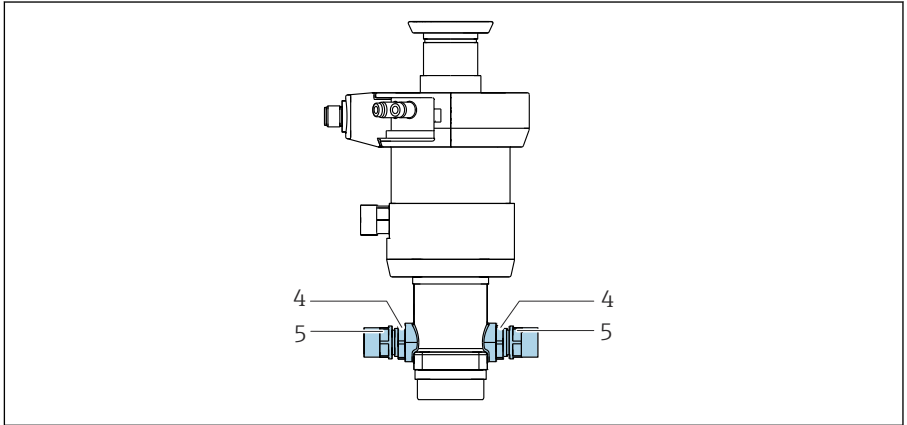

A0030292

▣ 43 Replacing seals, Part 3

4 Lock nut AF 19

5 Rinse connection adapter AF 17

Release the lock nuts (item 4) using a 19 mm open-ended wrench or socket wrench (in protective cover).

2. Unscrew the two rinse connection adapters (item 5).

3.

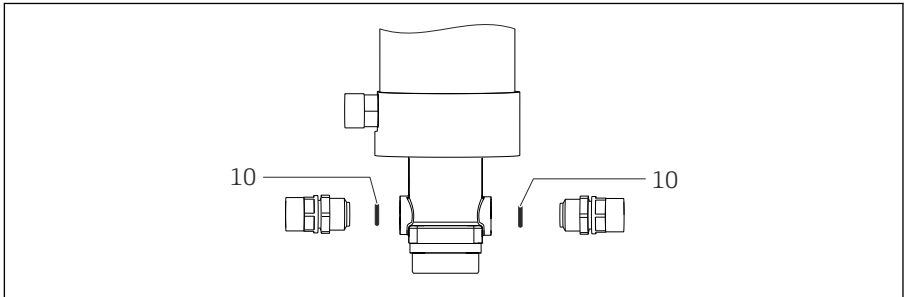

A0030315

▣ 44 Replacing seals, Part 3

10 O-rings, rinse connection adapter

Remove the O-rings indicated (item 10).

4. Apply a thin layer of grease (e.g., Klüber Paraliq GTE 703) to the new O-rings.

5. Insert the O-rings into the corresponding grooves.

Seal replacement in the immersion chamber

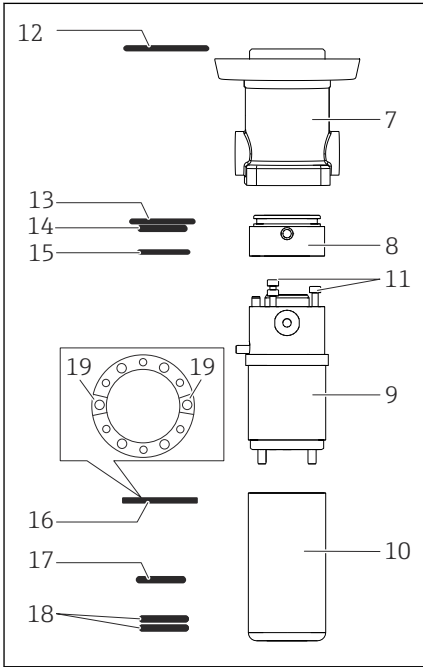

A0030329

- 7 Support housing
- 8 Immersion chamber - top part
- 9 Immersion chamber - middle part
- 10 Immersion chamber - bottom part
- 11 Securing screws, 2.5 mm (0.1 in) Allen screw
- 12 O-ring, support housing (pneumatic assembly only)
- 13 O-ring, top part of outer immersion chamber
- 14 O-ring, top part of inner immersion chamber
- 15 Molded seal (ensure correct orientation)
- 16 O-ring, bottom part of middle immersion chamber
- 17 O-rings, bottom part of immersion chamber (process seal)
- 18 Rinse chamber inlet and outlet



45

Replacing all seals

1. Remove the support housing (item 7) with the immersion chamber (items 8 - 10).
2. The rinse connection adapter must already have been removed.
Pull the immersion chamber out of the support housing.
3. Remove the top part of the immersion chamber (item 8).
4. Release the three screws (item 11)
5. Remove the bottom part of the immersion chamber.
6. Remove the O-rings and the molded seal (items 12 to 18).
7. Apply a thin layer of grease (e.g., Klüber Paraliq GTE 703) to the O-rings.
8. Insert the O-rings into the corresponding grooves.
9. Insert the molded seal in such a way that both openings with the stop ridges (item 19) are positioned above the rinse chamber inlet and outlet.

Reassembly

The inlet and outlet of the rinse connections are fixed in the immersion chamber version.

i When assembling the immersion chamber, please ensure that the leakage hole (item 11), the rinse connection outlet (item 12) and the marking on the bottom part of the immersion chamber (item 16) are all in one line.

Fit the components of the immersion chamber together

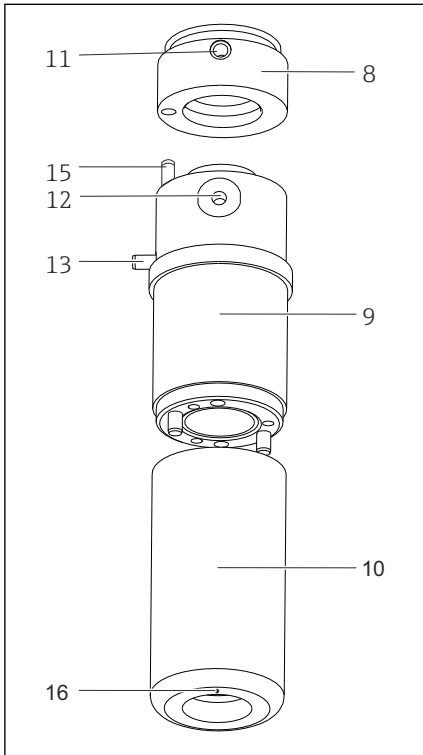

- 8 Immersion chamber - top part
- 9 Immersion chamber - middle part
- 10 Immersion chamber - bottom part
- 11 Leakage hole
- 12 Rinse connection - immersion chamber outlet
- 13 Positioning pin
- 15 Positioning pin
- 16 Position marking

i 46 Assembling the immersion chamber

1. Fit the bottom part (item 10) and middle part (item 9) of the immersion chamber together. Ensure correct orientation!
2. Screw both parts securely together using the three securing screws (item 11).
3. Attach the top part (item 8) of the immersion chamber.

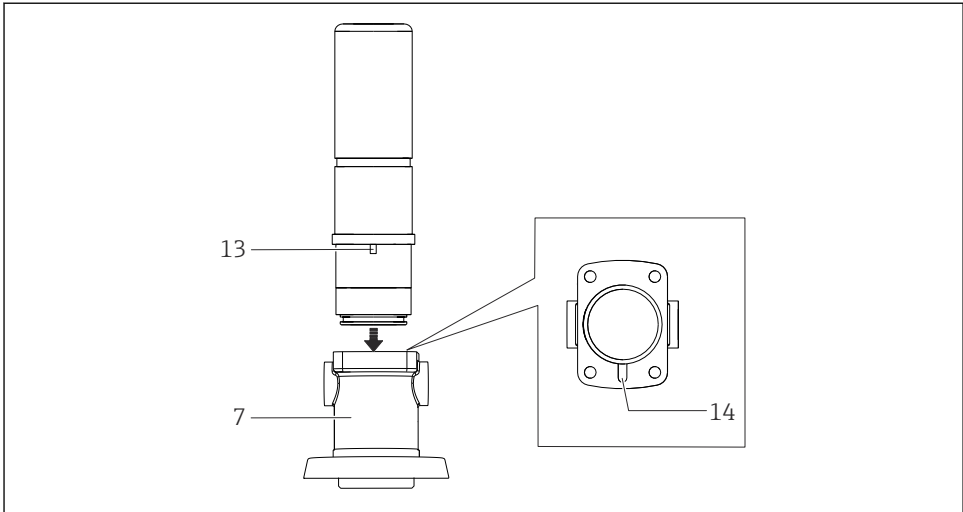

A0030347

47 *Assembling the support housing and immersion chamber*

- 7 *Support housing*
- 13 *Positioning pin*
- 14 *Positioning groove*

4. Place the support housing (item 7) on a level surface.
 - ↳ The positioning groove (item 14) is visible from above.
5. Place the immersion chamber on the support housing.
6. Slide the service chamber into the support housing.
7. Place the positioning pin (item 13) over the corresponding groove.
8. Push the service chamber into the groove.
9. Mount the process connection on the support housing.
10. Tighten the securing screws with a torque of 4 Nm.

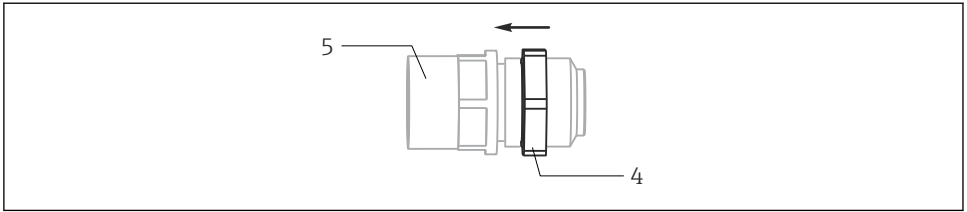

A0030344

48 *Assembling the rinse connection*

4 Lock nut AF 19

5 Rinse connection adapter AF 17

11. Turn the lock nut (item 4) on both of the rinse connection adapters (item 5) as far as possible in the direction of the arrow.
12. Insert the rinse connection adapters with O-rings into the support housing (open-ended wrench or socket wrench AF 17 mm).
13. Tighten the lock nut (AF 19 mm) in the opposite direction to the arrow.
14. Mount the support housing on the assembly. Pay attention to the positioning pin.
15. Tighten the securing screws with a torque of 4 Nm.

Test for leak-tightness

10. Seal the rinse chamber outlet with the plug.
11. Apply pressure to the rinse chamber inlet pneumatically (max. 6 bar absolute pressure)
12. Hold the assembly under water as far as the rinse chamber. In so doing, do not submerge the drive in the water.

The test is successful if no air bubbles appear.

8.2.5 Seal accessories

Seals, extension and ball valve

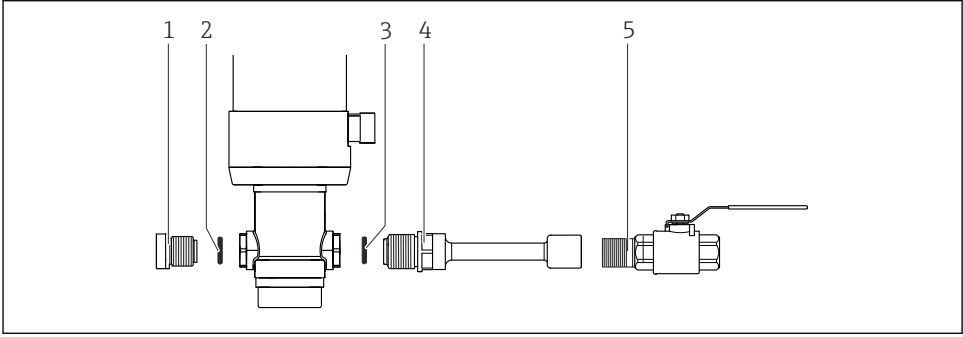

A0043794

- 1 Sealing plug
- 2 Flat seal
- 3 O-ring
- 4 Extension
- 5 Ball valve

1. Apply a thin layer of grease to the O-ring (3) and flat seal (2) (e.g., Klüber Paraliq GTE 703).
2. Place the O-ring (3) and flat seal (2) in the corresponding grooves of the rinse connections.
3. Mount the sealing plug (1) and extension (4).
4. Seal the ball valve (5) with a Teflon tape.
5. Screw the ball valve (5) into the extension (4).

Seals of the pressure retarder (PN16 version)

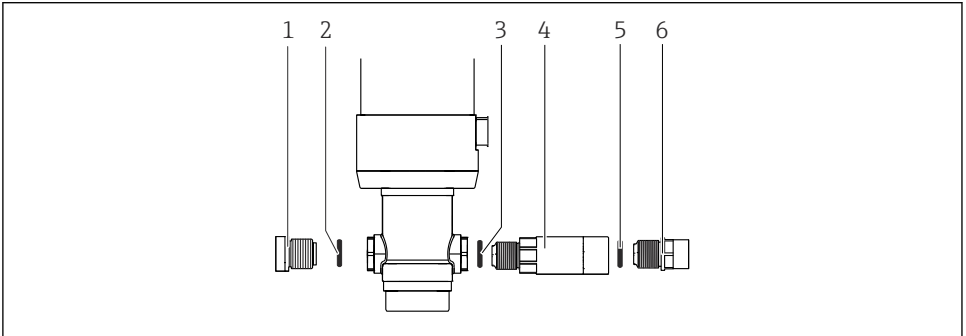

A0043795

- 1 *Dummy plug*
- 2 *Flat seal*
- 3 *O-ring*
- 4 *Pressure retarder*
- 5 *O-ring*
- 6 *Rinse connection*

1. Apply a thin layer of grease to the O-rings (3 and 5) and flat seal (2), (e.g. Klüber Paraliq GTE 703).
2. Place the flat seal (2) in the corresponding groove of the rinse connection inlet and install the dummy plug (1).
3. Place an O-ring (3) in the corresponding groove between the assembly and pressure retarder (4) and mount the pressure retarder.
4. Place an O-ring (5) in the corresponding groove between the pressure retarder (4) and rinse connection (6) and mount the rinse connection.

9 Repair

9.1 General information

WARNING

Danger resulting from improper repair!

- ▶ Any damage to the assembly that compromises pressure safety must be repaired only by authorized and qualified personnel.
- ▶ Damage to the drive can be repaired only at the place of manufacture. Repairs cannot be carried out onsite.
- ▶ Following each repair and maintenance task, check the assembly for leaks using appropriate procedures. Following this, the assembly must again comply with the specifications in the technical data.
- ▶ Replace all other damaged components immediately.

The repair and conversion concept provides for the following:

- The product has a modular design
- Spare parts are grouped into kits which include the associated kit instructions
- Only use original spare parts from the manufacturer
- Repairs are carried out by the manufacturer's Service Department or by trained users
- Certified devices can only be converted to other certified device versions by the manufacturer's Service Department or at the factory
- Observe applicable standards, national regulations, Ex documentation (XA) and certificates

1. Carry out the repair according to the kit instructions.
2. Document the repair and conversion and enter, or have entered, in the Life Cycle Management tool (W@M).

- ▶ Following repairs, check that the device is complete, in a safe condition and functioning correctly.

9.2 Spare parts

Spare parts currently available for the device can be found at: www.endress.com/onlinetools

- ▶ Quote the serial number of the device when ordering spare parts.

9.3 Return

The product must be returned if repairs or a factory calibration are required, or if the wrong product was ordered or delivered. As an ISO-certified company and also due to legal regulations, Endress+Hauser is obliged to follow certain procedures when handling any returned products that have been in contact with medium.

www.endress.com/support/return-material

9.4 Disposal



If required by the Directive 2012/19/EU on waste electrical and electronic equipment (WEEE), the product is marked with the depicted symbol in order to minimize the disposal of WEEE as unsorted municipal waste. Do not dispose of products bearing this marking as unsorted municipal waste. Instead, return them to the manufacturer for disposal under the applicable conditions.

10 Accessories

The following are the most important accessories available at the time this documentation was issued.

Listed accessories are technically compatible with the product in the instructions.

1. Application-specific restrictions of the product combination are possible. Ensure conformity of the measuring point to the application. This is the responsibility of the operator of the measuring point.
2. Pay attention to the information in the instructions for all products, particularly the technical data.
3. For accessories not listed here, please contact your Service or Sales Center.

The following accessories can be ordered via the product structure or the XPC0001 spare part structure:

- Weld-in adapter G1¼, straight, 35 mm, 1.4435 (AISI 316 L), safety nozzle
- Weld-in adapter G1¼, angled, 35 mm, 1.4435 (AISI 316 L), safety nozzle

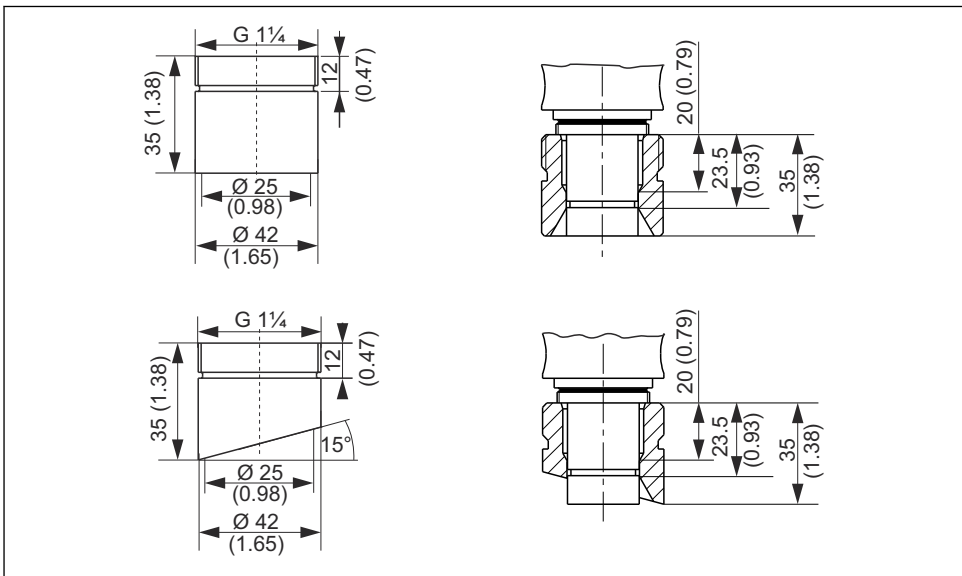

A0028744

■ 49 Weld-in adapter (safety nozzle), dimensions in mm (in)

- Dummy plug G1¼, 1.4435 (AISI 316 L), FPM - FDA
- Sensor dummy 120 mm, 1.4435 (AISI 316 L), Ra = 0.38 µm
- Sensor dummy 225 mm, 1.4435 (AISI 316 L), Ra = 0.38 µm
- Sensor dummy 360 mm, 1.4435 (AISI 316 L), Ra = 0.38 µm
- Kit, seals for non-wetted parts
- Kit, FKM seals, G1¼, wetted parts
- Kit, FKM seals, immersion chamber version, wetted parts

- Kit, seal, wetted, EPDM
- Kit, seal, wetted, FKM
- Kit, seal, FFKM, basic, wetted
- Cable, plug-in, limit switch, M12, 5 m
- Cable, plug-in, limit switch, M12, 10 m
- Tool in case for installation/removal
- Kit, Klüber Paraliq GTE 703 lubricant (60g)
- Output interface terminals, version: CPA871-620-R7
 - NAMUR terminals for limit position switches
 - Operation of 8V DC feedback signals on 24V DC devices
 - Suitable for top-hat rail mounting

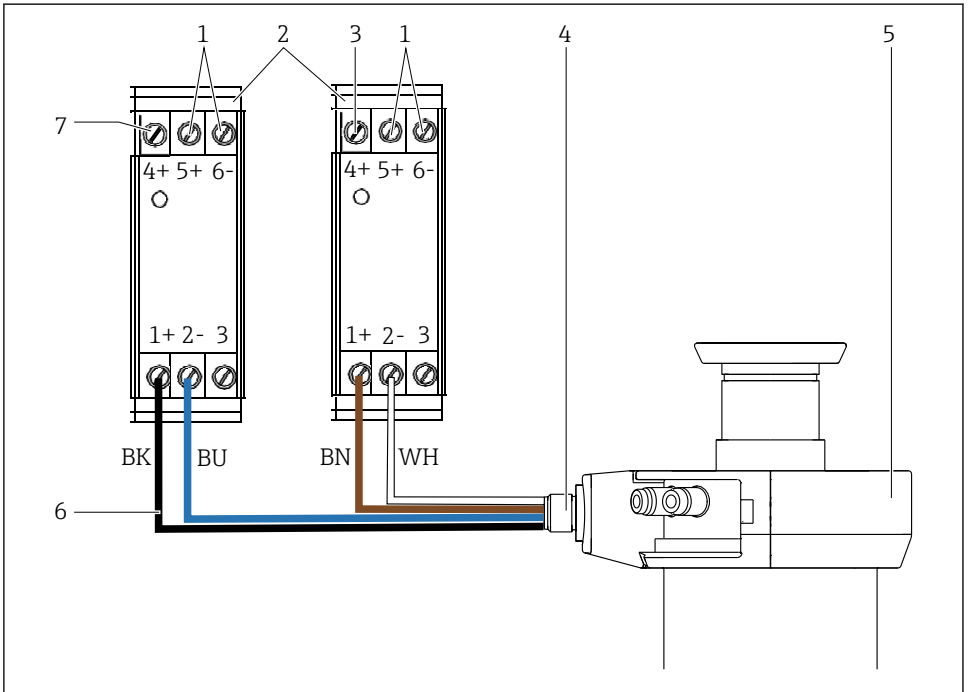

50 Wiring of output interface terminal with assembly

- 1 Supply voltage
- 2 Output interface terminals
- 3 Output measuring position
- 4 Limit position switches
- 5 Assembly
- 6 Cable for wiring → 70
- 7 Output service position

10.1 Device-specific accessories

10.1.1 Sensors

pH sensors

Memosens CPS11E

- pH sensor for standard applications in process and environmental engineering
- Digital with Memosens 2.0 technology
- Product Configurator on the product page: www.endress.com/cps11e



Technical Information TI01493C

Orbisint CPS11

- pH sensor for process technology
- With dirt-repellent PTFE diaphragm
- Product Configurator on the product page: www.endress.com/cps11



Technical Information TI00028C

Memosens CPS31E

- pH sensor for standard applications in drinking water and swimming pool water
- Digital with Memosens 2.0 technology
- Product Configurator on the product page: www.endress.com/cps31e



Technical Information TI01574C

Memosens CPS41E

- pH sensor for process technology
- With ceramic junction and KCl liquid electrolyte
- Digital with Memosens 2.0 technology
- Product Configurator on the product page: www.endress.com/cps41e



Technical Information TI01495C

Ceraliquid CPS41

- pH electrode with ceramic junction and KCl liquid electrolyte
- Product Configurator on the product page: www.endress.com/cps41



Technical Information TI00079C

Memosens CPS61E

- pH sensor for bioreactors in life sciences and for the food industry
- Digital with Memosens 2.0 technology
- Product Configurator on the product page: www.endress.com/cps61e



Technical Information TI01566C

Memosens CPS71E

- pH sensor for chemical process applications
- Digital with Memosens 2.0 technology
- Product Configurator on the product page: www.endress.com/cps71e



Technical Information TI01496C

Ceragel CPS71

- pH electrode with reference system including ion trap
- Product Configurator on the product page: www.endress.com/cps71



Technical Information TI00245C

Memosens CPS91E

- pH sensor for heavily polluted media
- Digital with Memosens 2.0 technology
- Product Configurator on the product page: www.endress.com/cps91e



Technical Information TI01497C

Orbipore CPS91

- pH electrode with hole junction for media with high dirt load
- Product Configurator on the product page: www.endress.com/cps91



Technical Information TI00375C

ORP sensors**Memosens CPS12E**

- ORP sensor for standard applications in process and environmental engineering
- Digital with Memosens 2.0 technology
- Product Configurator on the product page: www.endress.com/cps12e



Technical Information TI01494C

Orbisint CPS12

- ORP sensor for process technology
- Product Configurator on the product page: www.endress.com/cps12



Technical Information TI00367C

Memosens CPS42E

- ORP sensor for process technology
- Digital with Memosens 2.0 technology
- Product Configurator on the product page: www.endress.com/cps42e



Technical Information TI01575C

Ceraliquid CPS42

- ORP electrode with ceramic junction and KCl liquid electrolyte
- Product Configurator on the product page: www.endress.com/cps42



Technical Information TI00373C

Memosens CPS72E

- ORP sensor for chemical process applications
- Digital with Memosens 2.0 technology
- Product Configurator on the product page: www.endress.com/cps72e



Technical Information TI01576C

Ceragel CPS72

- ORP electrode with reference system including ion trap
- Product Configurator on the product page: www.endress.com/cps72



Technical Information TI00374C

pH ISFET sensors**Memosens CPS47E**

- ISFET sensor for pH measurement
- Digital with Memosens 2.0 technology
- Product Configurator on the product page: www.endress.com/cps47e



Technical Information TI01616C

Memosens CPS77E

- Sterilizable and autoclavable ISFET sensor for pH measurement
- Digital with Memosens 2.0 technology
- Product Configurator on the product page: www.endress.com/cps77e



Technical Information TI01396

Combined pH/ORP sensors**Memosens CPS16E**

- pH/ORP sensor for standard applications in process technology and environmental engineering
- Digital with Memosens 2.0 technology
- Product Configurator on the product page: www.endress.com/cps16e



Technical Information TI01600C

Memosens CPS76E

- pH/ORP sensor for process technology
- Digital with Memosens 2.0 technology
- Product Configurator on the product page: www.endress.com/cps76e



Technical Information TI01601C

Memosens CPS96E

- pH/ORP sensor for heavily polluted media and suspended solids
- Digital with Memosens 2.0 technology
- Product Configurator on the product page: www.endress.com/cps96e



Technical Information TI01602C

Conductivity sensors**Memosens CLS82E**

- Hygienic conductivity sensor
- Digital with Memosens 2.0 technology
- Product Configurator on the product page: www.endress.com/cls82e



Technical Information TI01529C



The sensor is suitable for the assembly with the following sensor lengths:
120 mm (4.7 in), 215 mm (8.5 in) and 360 mm (14.2 in)

Oxygen sensors**Oxymax COS22E**

- Sterilizable sensor for dissolved oxygen
- Digital with Memosens 2.0 technology
- Product Configurator on the product page: www.endress.com/cos22e



Technical Information TI00446C



The sensor is suitable for the assembly with the following sensor lengths:
120 mm (4.7 in), 215 mm (8.5 in) and 360 mm (14.2 in)

Oxymax COS22

- Sterilizable sensor for dissolved oxygen
- With Memosens technology or as an analog sensor
- Product Configurator on the product page: www.endress.com/cos22



Technical Information TI00446C

Absorption sensor

OUSBT66

- NIR absorption sensor for the measurement of cell growth and biomass
- Sensor version suitable for pharmaceutical industry
- Product Configurator on the product page: www.endress.com/ousbt66



Technical Information TI00469C



The assembly can only be used with the absorption sensor with the optical path lengths 5 mm (0.2 in) and 10 mm (0.39 in).

10.2 Service-specific accessories

10.2.1 Cleaning systems

Air-Trol 500

- Control unit for Cleanfit retractable assemblies
- Order No. 50051994



Technical Information TI00038C/07/EN

Cleanfit Control CYC25

- Converts electrical signals into pneumatic signals to control pneumatically-operated retractable assemblies or pumps in conjunction with Liquiline CM44x
- Wide range of control options
- Product Configurator on the product page: www.endress.com/cyc25



Technical Information TI01231C

Liquiline Control CDC90

- Fully automatic cleaning and calibration system for pH and ORP measuring points in all industries
- Cleaned, validated, calibrated and adjusted
- Product Configurator on the product page: www.endress.com/cdc90



Technical Information TI01340C

10.2.2 Flow vessel

- Flange DN 25 ISO 1092-2 PN16
- Material: stainless steel 1.4404 (AISI 316 L)
- Can be ordered with assembly with G 1 1/4" process connection CPA871-+++C+ANA++NI or as spare part XPC0003-V+QI

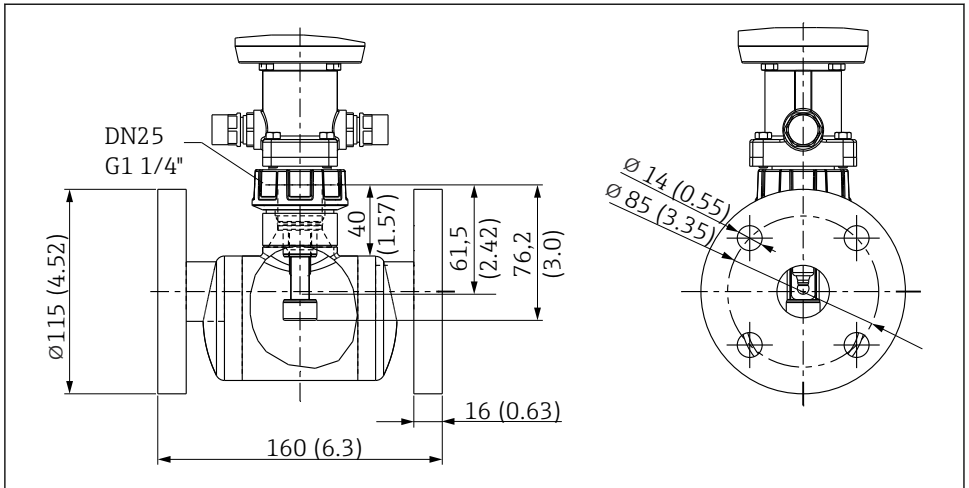

A0047541

51 Dimensions in mm (in)



Dummy plug is available for maintenance purposes

10.3 Installation material for rinse connections

Kit, water filter

- Water filter (dirt trap) 100 μm , complete, incl. angle bracket
- Order No. 71390988

Pressure reducer kit

- Complete, incl. manometer and angle bracket
- Order No. 71390993

Hose connection set G $\frac{1}{4}$, DN 12

- 1.4404 (AISI 316L) 2 x
- Order No. 51502808

Hose connection set G $\frac{1}{4}$, DN 12

- PVDF (2 x)
- Order No. 50090491

11 Technical data

11.1 Installation

11.1.1 Sensor selection

Depending on the assembly version.

Short version	Gel electrodes, ISFET	120 mm (4.7 in)
	Gel electrodes, ISFET	225 mm (8.9 in)
	KCl electrode	225 mm (8.9 in)
Long version	Gel electrodes, ISFET	225 mm (8.9 in)
	Gel electrodes, ISFET	360 mm (14.2 in)
Immersion chamber version (short)	Gel electrodes, ISFET	225 mm (8.9 in)
	KCl electrode	360 mm (14.2 in)
Immersion chamber version (long)	Gel+KCl	360 mm (14.2 in)

11.1.2 Limit position switches

Switching element function:	NAMUR NC contact (inductive)
Switching distance:	1.5 mm (0.06 ")
Nominal voltage:	8 V
Switching frequency:	0 to 5000 Hz
Housing material:	Stainless steel
Output interface terminals	NAMUR
Limit position switches (inductive conductivity sensors)	Pepperl+Fuchs NJ1,5-6,5-15-N-Y180094

11.2 Environment

11.2.1 Ambient temperature range

-10 to 70 °C (14 to 158 °F)

11.2.2 Storage temperature

-10 to 70 °C (14 to 158 °F)

11.2.3 Degree of protection

IP66

11.2.4 Vibration resistance and shock resistance

Sinusoidal similar to DIN EN IEC 60068-2-6

- 2-8.4 Hz, 7.5 mm peak
- 8.4-2000 Hz, 5 g peak

Broadband noise similar to DIN EN IEC 60068-2-64

- 10-200 Hz, 0.01 g²/Hz
- 8200-2000 Hz, 0.003 g²/Hz
- Total: 2.70 g rms

Shocks (half-sine) similar to DIN EN IEC 60068-2-2
30 g, 6 ms

11.3 Process

11.3.1 Process temperature range

For all materials except PVDF, PVDF conductive and PP

-10 to 140 °C (14 to 284 °F)

PVDF and PVDF conductive

-10 to ¹⁰⁰/₉₀ °C (14 to ²¹²/₁₉₄ °F)

PP

0 to 60 °C (32 to 140 °F)

11.3.2 Process pressure range

Pneumatic drive 16 bar (232 psi) to 140 °C (284 °F)

Manual drive 8 bar (116 psi) to 140 °C (284 °F)

(PP version may vary)



The service life of the seals is reduced if process temperatures are constantly high or if SIP is used. The other process conditions may also reduce the service life of the seals.

Process pressure for pneumatic drive

Materials	Basic version	Immersion chamber version
1.4404, Alloy C22, PEEK	16 bar (232 psi) to 140 °C (284 °F)	16 bar (232 psi) to 140 °C (284 °F)
PVDF, PVDF conductive	16 bar (232 psi) to 100 °C (212 °F)	4 bar (58 psi) to 90 °C (194 °F)
PP (polypropylene)	6 bar (87 psi) to 20 °C (68 °F)	-



The service life of the seals is reduced if process temperatures are constantly high or if SIP is used. The other process conditions may also reduce the service life of the seals.



Depending on the version, the process pressure must be reduced to insert/retract the assembly.

Process pressure for manual drive

Materials	Basic version	Immersion chamber version
1.4404, Alloy C22, PEEK	8 bar (116 psi) to 140 °C (284 °F)	8 bar (116 psi) to 140 °C (284 °F)
PVDF, PVDF conductive	8 bar (116 psi) to 100 °C (212 °F)	4 bar (58 psi) to 90 °C (194 °F)
PP (polypropylene)	6 bar (87 psi) to 20 °C (68 °F)	-

i The service life of the seals is reduced if process temperatures are constantly high or if SIP is used. The other process conditions may also reduce the service life of the seals.

11.3.3 Pressure/temperature ratings

Manual and pneumatic drive, insertion/retraction up to 6 bar

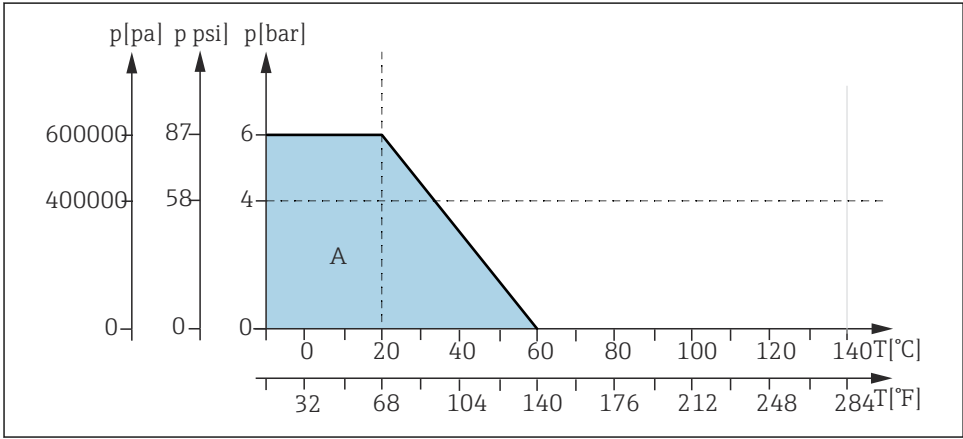

A0042959

52 Pressure/temperature ratings for basic version for the material PP (CPA871\-*H*)

A Basic version

Manual drive, insertion/retraction up to 8 bar

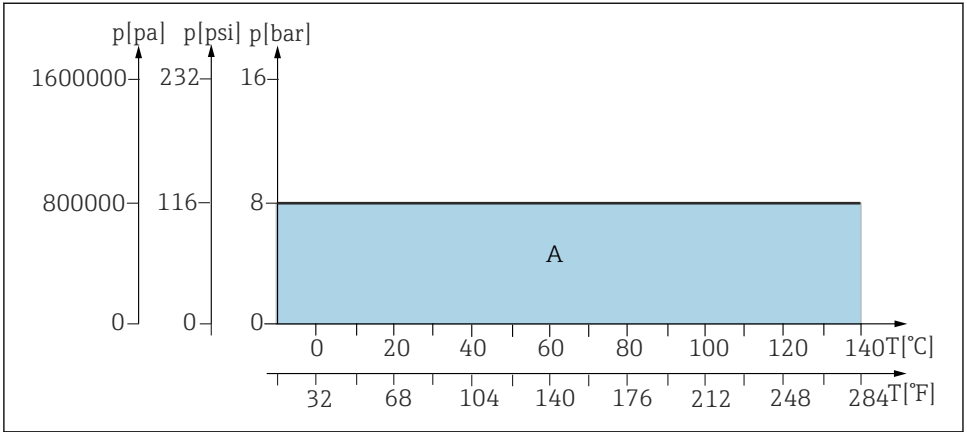

A0039156

53 Pressure temperature ratings for basic and immersion chamber version for materials 1.4404, Alloy C22 and PEEK

A Basic and immersion chamber version

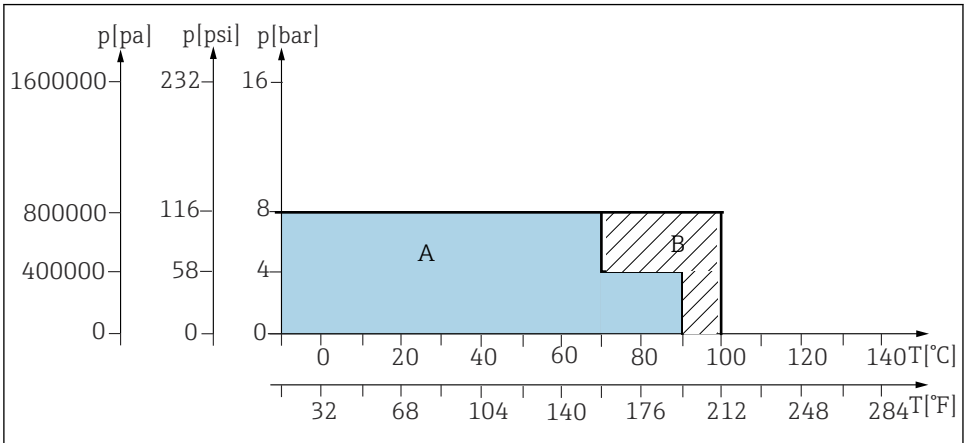

A0039156

54 Pressure temperature ratings for basic version for materials PVDF and conductive PVDF

A Immersion chamber version

B Basic version

Pneumatic drive, insertion/retraction up to 8 bar (static pressure resistance up to 16 bar)

NOTICE

Process seal can be damaged if the pressure during insertion/retraction is too high.

Medium escaping from the assembly

- ▶ Assembly insertion/retraction at 8 bar.

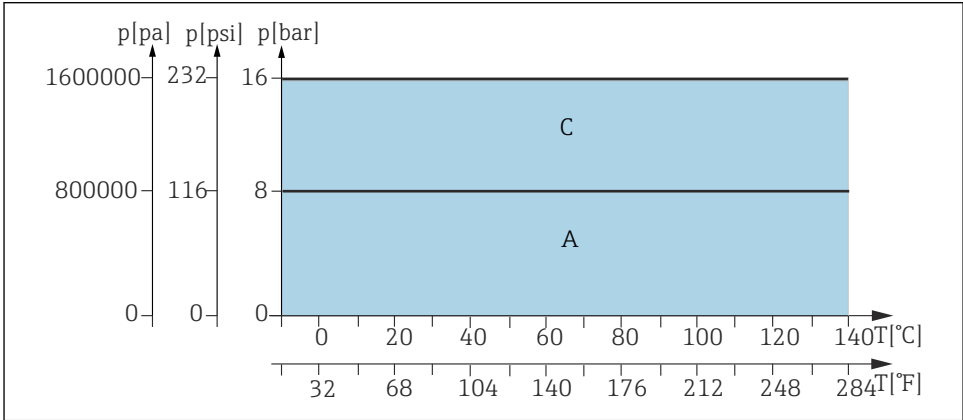

A0039268

55 Pressure/temperature ratings for basic and immersion chamber version for 1.4404, Alloy C22 and PEEK materials (CPA871-**G/H*****)

- A Basic and immersion chamber version
- C Static range, assembly insertion/retraction not permitted

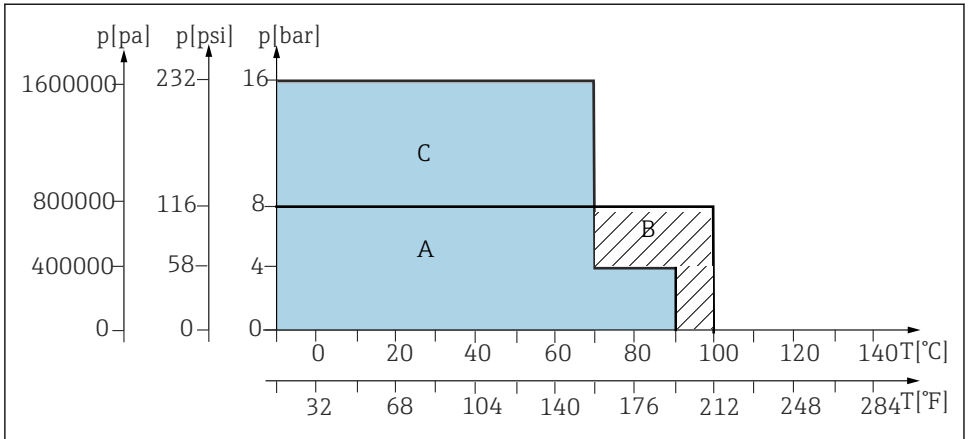

A0039267

56 Pressure/temperature ratings for basic version for PVDF and conductive PVDF materials (CPA871-**G/H*****)

- A Immersion chamber version
- B Basic version
- C Static range, assembly insertion/retraction not permitted

Pneumatic drive, insertion/retraction up to 16 bar

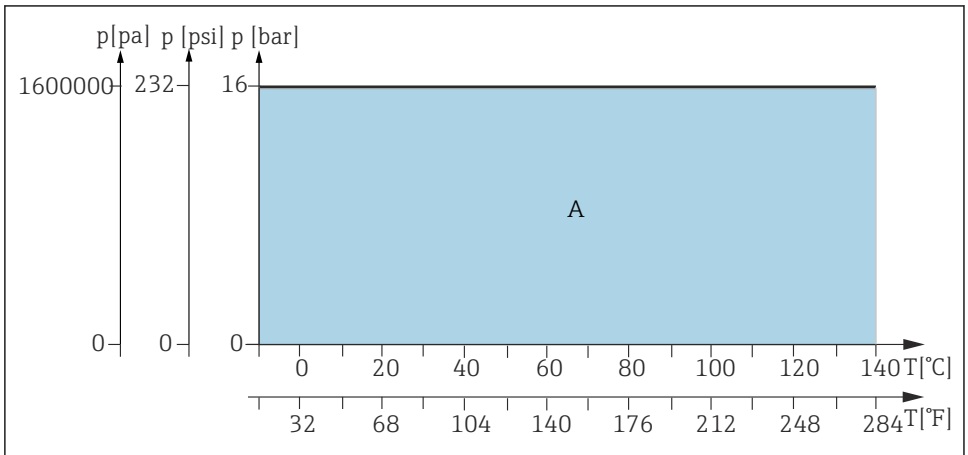

A0039157

57 Pressure/temperature ratings for basic and immersion chamber version for 1.4404, Alloy C22 and PEEK materials (CPA871-**E/F*****)

- A Basic and immersion chamber version

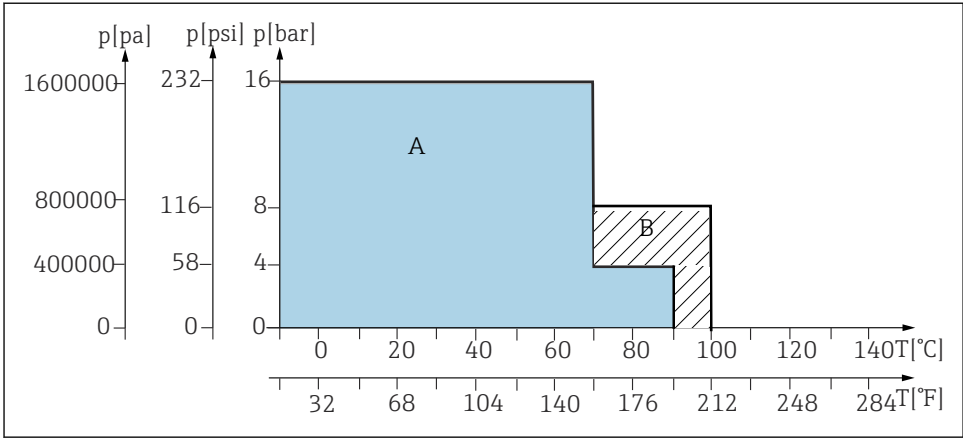

A0039162

58 Pressure/temperature ratings for basic version for PVDF and conductive PVDF materials (CPA871-
E/F***)

- A Immersion chamber version
- B Basic version

11.4 Mechanical construction

11.4.1 Design and dimensions

→ Section "Installation"

11.4.2 Rinse chamber volume

	Volume cm ³ (in ³)(max.)	Volume cm ³ (in ³) (min.)
Single chamber	12.02 (0.73)	2.81 (0.17)
Immersion chamber, short	15.75 (0.96)	6.73 (0.41)
Immersion chamber, long	17.14 (1.05)	8.12 (0.5)

11.4.3 Weight

Depends on version:

- Pneumatic drive: 3.8 to 6 kg (8.4 to 13.2 lbs) depending on version
- Manual drive: 3 to 4.5 kg (6.6 to 9.9 lbs) depending on version

11.4.4 Materials

In contact with medium	
Seals:	EPDM / FKM / FFKM
Immersion tube, process connection, service chamber:	Stainless steel 1.4404 (AISI 316L) Ra < 0.76 / PEEK / Alloy C22 Ra < 0.76 / PVDF / PVDF conductive / PP
Rinse connections:	Stainless steel 1.4404 (AISI 316L) or Alloy C22

Not in contact with medium	
Manual drive:	Stainless steel 1.4301 (AISI 304) or 1.4404 (AISI 316L), plastics PPS CF15, PBT, PP
Pneumatic drive:	Stainless steel 1.4301 (AISI 304) or 1.4404 (AISI 316L), plastics PBT, PP

11.4.5 Rinse connections

Surface finish may vary depending on the manufacturing process.

Index

A

Accessories 70

C

Cleaning 48

Cleaning agent 47

Connection

 Pneumatics 23

D

Dimensions 13

Disposal 69

F

Failure of compressed air supply 45

I

Immersion depths 18

Incoming acceptance 10

Installation 11

Installation check 41

Installation conditions 11

Installation procedure 20

Installation requirements 11

Intended use 5

L

Limit position switches 31

M

Maintenance 46

Maintenance intervals 46

Maintenance schedule 46

Manual operation 44

Measuring system 20

N

Nameplate 10

O

O-rings 49

Operating 42

Operation

 Manual 44

 Pneumatic 44

P

Pneumatic connection 23

Pneumatic operation 44

Product identification 10

R

Repair 68

Return 68

Rinse connections 25, 85

S

Safety information 4

Safety instructions 5

Scope of delivery 10

Seals 49

Sensor installation 34

Spare parts 68

Symbols 4

T

Technical data 78

U

Use 5



71763545

www.addresses.endress.com
