

Safety Instructions

Levelflex

FMP50/51/52/53/54/55/56/57

PROFIBUS PA, FOUNDATION Fieldbus

Ex ic IIC T6...T1 Gc
Ex nA IIC T6...T1 Gc

Segurança



Document: XA01193F-D

Safety instructions for electrical apparatus for explosion-hazardous areas → 3

Document: XA01193F-D

Temperature tables → 15

Levelflex FMP50/51/52/53/54/55/56/57

PROFIBUS PA, FOUNDATION Fieldbus

Table of contents

Associated documentation	4
Supplementary documentation	4
Manufacturer's certificates	4
Manufacturer address	4
Extended order code	4
Safety instructions: General	7
Safety instructions: Special conditions	7
Safety instructions: Installation	8
Temperature tables	11
Connection data	11

Associated documentation	<p>This document is an integral part of the following Operating Instructions:</p> <p>PROFIBUS PA</p> <ul style="list-style-type: none"> ■ BA01005F/00 (FMP50) ■ BA01006F/00 (FMP51, FMP52, FMP54) ■ BA01007F/00 (FMP53) ■ BA01008F/00 (FMP55) ■ BA01009F/00 (FMP56, FMP57) <p>FOUNDATION Fieldbus</p> <ul style="list-style-type: none"> ■ BA01051F/00 (FMP50) ■ BA01052F/00 (FMP51, FMP52, FMP54) ■ BA01053F/00 (FMP53) ■ BA01054F/00 (FMP55) ■ BA01055F/00 (FMP56, FMP57) 										
Supplementary documentation	<p>Explosion-protection brochure: CP00021Z/11</p> <p>The Explosion-protection brochure is available:</p> <ul style="list-style-type: none"> ■ In the download area of the Endress+Hauser website: www.endress.com -> Downloads -> Brochures and Catalogs -> Text Search: CP00021Z ■ On the CD for devices with CD-based documentation 										
Manufacturer's certificates	<p>Certificate of Conformity</p> <p>Certificate number: DEKRA 13.0006 X</p> <p>Affixing the certificate number certifies conformity with the following standards (depending on the device version):</p> <ul style="list-style-type: none"> ■ ABNT NBR IEC 60079-0 : 2013 ■ ABNT NBR IEC 60079-11 : 2013 ■ ABNT NBR IEC 60079-15 : 2012 										
Manufacturer address	<p>Endress+Hauser SE+Co. KG Hauptstraße 1 79689 Maulburg, Germany Address of the manufacturing plant: See nameplate.</p>										
Extended order code	<p>The extended order code is indicated on the nameplate, which is affixed to the device in such a way that it is clearly visible. Additional information about the nameplate is provided in the associated Operating Instructions.</p> <p>Structure of the extended order code</p> <table border="0" style="margin-left: 40px;"> <tr> <td style="text-align: center;">FMP5x</td> <td style="text-align: center;">-</td> <td style="text-align: center;">*****</td> <td style="text-align: center;">+</td> <td style="text-align: center;">A*B*C*D*E*F*G*..</td> </tr> <tr> <td style="text-align: center;"><i>(Device type)</i></td> <td></td> <td style="text-align: center;"><i>(Basic specifications)</i></td> <td></td> <td style="text-align: center;"><i>(Optional specifications)</i></td> </tr> </table> <p>* = Placeholder At this position, an option (number or letter) selected from the specification is displayed instead of the placeholders.</p> <p><i>Basic specifications</i></p> <p>The features that are absolutely essential for the device (mandatory features) are specified in the basic specifications. The number of positions depends on the number of features available. The selected option of a feature can consist of several positions.</p>	FMP5x	-	*****	+	A*B*C*D*E*F*G*..	<i>(Device type)</i>		<i>(Basic specifications)</i>		<i>(Optional specifications)</i>
FMP5x	-	*****	+	A*B*C*D*E*F*G*..							
<i>(Device type)</i>		<i>(Basic specifications)</i>		<i>(Optional specifications)</i>							

Optional specifications

The optional specifications describe additional features for the device (optional features). The number of positions depends on the number of features available. The features have a 2-digit structure to aid identification (e.g. JA). The first digit (ID) stands for the feature group and consists of a number or a letter (e.g. J = Test, Certificate). The second digit constitutes the value that stands for the feature within the group (e.g. A = 3.1 material (wetted parts), inspection certificate).

More detailed information about the device is provided in the following tables. These tables describe the individual positions and IDs in the extended order code which are relevant to hazardous locations.

Extended order code: Levelflex



The following specifications reproduce an extract from the product structure and are used to assign:

- This documentation to the device (using the extended order code on the nameplate).
- The device options cited in the document.

Device type

FMP50, FMP51, FMP52, FMP53, FMP54, FMP55, FMP56, FMP57

Basic specifications

Position 1, 2 (Approval)		
Selected option		Description
FMP5x	MG ¹⁾	INMETRO Ex nA IIC T6...T1 Gc
	MH ²⁾	INMETRO Ex ic IIC T6...T1 Gc

- 1) The designation changes in connection with Position 4 (Display, Operation) = L, M, N:
Ex nA [ia Ga] IIC T6...T1 Gc
- 2) The designation changes in connection with Position 4 (Display, Operation) = L, M, N:
Ex ic [ia Ga] IIC T6...T1 Gc

Position 3 (Power Supply, Output)		
Selected option		Description
FMP5x	E	2-wire, FOUNDATION Fieldbus, switch output (PFS)
	G	2-wire, PROFIBUS PA, switch output (PFS)

Position 4 (Display, Operation)		
Selected option		Description
FMP5x	A	Without, via communication
	C	SD02, 4-line, push buttons + data backup function
	E	SD03, 4-line, illum., touch control + data backup function
	L ^{1) 2)}	Prepared for display FHX50 + M12 connection
	M ^{1) 2)}	Prepared for display FHX50 + custom connection
	N ^{2) 3)}	Prepared for display FHX50 + NPT1/2"

- 1) In connection with Position 5 (Housing) = A: Observe the specifications in the "Overvoltage protection" and "Temperature tables" chapters!
- 2) Only in connection with Position 1, 2 (Approval) = MH
- 3) Only in connection with Position 5 (Housing) = B, C

Position 5 (Housing)		
Selected option		Description
FMP5x	A ¹⁾	GT19 dual compartment, plastics PBT
	C	GT20 dual compartment, Alu coated
FMP51 FMP52 FMP54-57	B	GT18 dual compartment, 316L

1) Only in connection with Position 1, 2 (Approval) = MH

Position 6 (Electrical Connection)		
Selected option		Description
FMP5x	A	Gland M20, IP66/68 NEMA4X/6P
	B	Thread M20, IP66/68 NEMA4X/6P
	C	Thread G1/2, IP66/68 NEMA4X/6P
	D	Thread NPT1/2, IP66/68 NEMA4X/6P
	I ^{1) 2)}	Plug M12, IP66/68 NEMA4X/6P
	M ^{1) 3)}	Plug 7/8", IP66/68 NEMA4X/6P

1) Only in connection with Position 1, 2 (Approval) = MH

2) Only in connection with Position 3 (Power Supply, Output) = G

3) Only in connection with Position 3 (Power Supply, Output) = E

Position 9, 10 (Seal)		
Selected option		Description
FMP50	A1	Viton, -20...80 °C
FMP51	A4	Viton, -30...150 °C
	B3	EPDM, -40...120 °C
	C3	Kalrez, -20...200 °C
	E1	FVMQ, -50...150 °C
FMP53	AD	FKM, FDA, USP Cl. VI, -10...150 °C
	B5	EPDM, FDA, USP Cl. VI, -20...130 °C
	C4	Kalrez, FDA, USP Cl. VI, -20...150 °C
FMP54	D1	Graphite, -196...280 °C (XT)
	D2	Graphite, -196...450 °C (HT)
FMP56	AB	Viton, -30...120 °C
	B3	EPDM, -40...120 °C
FMP57	A4	Viton, -30...150 °C
	B3	EPDM, -40...120 °C
	C5	Kalrez, -5...185 °C

Optional specifications

ID Jx (Test; Certificate)		
Selected option		Description
FMP51 ¹⁾ FMP54	JN ²⁾	Ambient temperature transmitter -50 °C

- 1) Only in connection with Position 9, 10 (Seal) = E1
- 2) Only in connection with Position 1, 2 (Approval) = MH and Position 5 (Housing) = B, C

ID Mx (Probe Design)		
Selected option		Description
FMP5x	MB	Sensor remote, 3 m/9 ft cable, detachable + mounting bracket
FMP53	MA	Sensor compact, detachable
FMP50-54 FMP56	MC	Sensor remote, 6 m/18 ft cable, detachable + mounting bracket
FMP57	MD	Sensor remote, 9 m/27 ft cable, detachable + mounting bracket

ID Nx, Ox (Accessory Mounted)		
Selected option		Description
FMP5x	NA	Overvoltage protection
FMP51 FMP52 FMP55	NC	Gas-tight feed through

Safety instructions: General

- Staff must meet the following conditions for mounting, electrical installation, commissioning and maintenance of the device:
 - Be suitably qualified for their role and the tasks they perform
 - Be trained in explosion protection
 - Be familiar with national regulations
- Install the device according to the manufacturer's instructions and national regulations.
- Do not operate the device outside the specified electrical, thermal and mechanical parameters.
- Only use the device in media to which the wetted materials have sufficient durability.
- Avoid electrostatic charging:
 - Of plastic surfaces (e.g. housing, sensor element, special varnishing, attached additional plates, ..)
 - Of isolated capacities (e.g. isolated metallic plates)
- Modifications to the device can affect the explosion protection and must be carried out by staff authorized to perform such work by Endress+Hauser.
- Refer to the temperature tables for the relationship between the permitted ambient temperature for the sensor and/or transmitter, depending on the range of application and the temperature class.
- When replacing the probe electronics or opening the connection between the remote cable and the probe, a jumper plug must be used or a short-circuit must be established between the probe contact and the potential equalization conductor to avoid electrostatically charging the probe.

**Safety instructions:
Special conditions**

Permitted ambient temperature range at the electronics housing:
 $-40\text{ °C} \leq T_a \leq +80\text{ °C}$

Optional specification, ID Jx (Test, Certificate) = JN

Permitted ambient temperature range at the electronics housing:
 $-50\text{ °C} \leq T_a \leq +80\text{ °C}$

- Observe the information in the temperature tables.
- In the case of process connections made of polymeric material or with polymeric coatings, avoid electrostatic charging of the plastic surfaces.
- To avoid electrostatic charging: Do not rub surfaces with a dry cloth.
- In the event of additional or alternative special varnishing on the housing or other metal parts or for adhesive plates:
 - Observe the danger of electrostatic charging and discharge.
 - Do not install in the vicinity of processes (≤ 0.5 m) generating strong electrostatic charges.
- Secure probes against swinging: e.g. by fixing them to the wall or floor or by installing them in the ground tube.

Basic specification, Position 5 (Housing) = A

Avoid electrostatic charging of the housing (e.g. friction, cleaning, maintenance, strong medium flow).

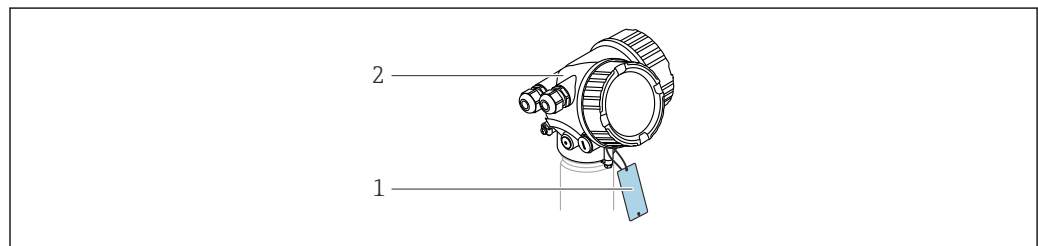

A0032146

1

- 1 Isolated capacitance:
 with one metal plate: ≤ 3 pF (permitted in all areas for Equipment Groups II and III)
 with two to three metal plates: ≤ 10 pF (not permitted in Zone 0 and for Equipment Group IIC)
- 2 Housing

Device type FMP52, FMP55 and Device type FMP5x with non-conductive plastic coated probes
 A probe coated with non-conductive material can be used if avoiding electrostatic charging (e.g. through friction, cleaning, maintenance, strong medium flow).

Safety instructions: Installation

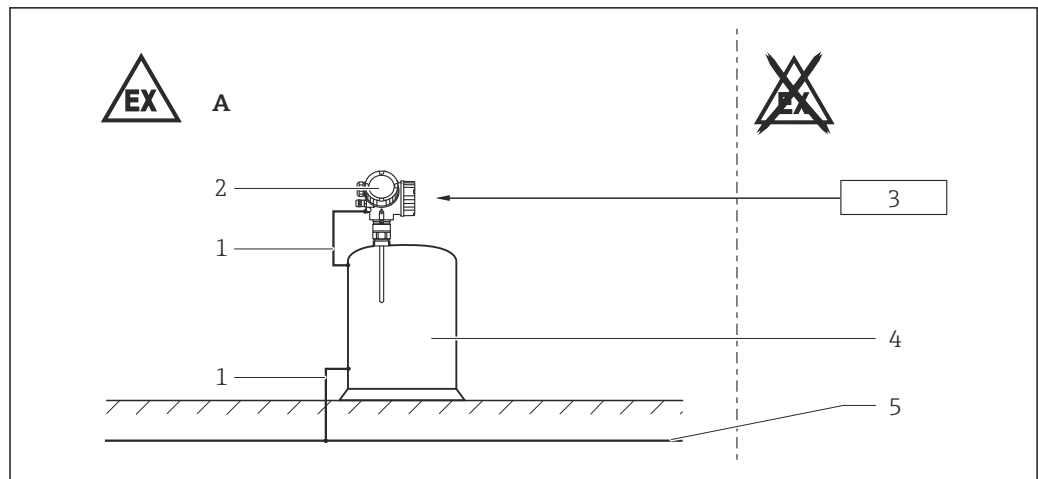

A0022629

2

- A Zone 2
- 1 Potential equalization line
- 2 Electronic insert
- 3 Ex ic: Certified associated apparatus; Ex nA: Supply depending upon equipment version
- 4 Tank; Zone 2
- 5 Potential equalization

- After aligning (rotating) the housing, retighten the fixing screw (see Operating Instructions).
- Install the device to exclude any mechanical damage or friction during the application. Pay particular attention to flow conditions and tank fittings.
- After mounting and connecting the probe, ingress protection of the housing must be at least IP65.
- Perform the following to achieve the degree of protection:
 - Screw the cover tight.
 - Mount the cable entry correctly.
- Continuous service temperature of the connecting cable: -40 °C to $\geq +85\text{ °C}$; in accordance with the range of service temperature taking into account additional influences of the process conditions ($T_{a,\min}$), ($T_{a,\max} + 20\text{ K}$).

Optional specification, ID Jx (Test, Certificate) = JN

Continuous service temperature of the connecting cable: -50 °C to $\geq +85\text{ °C}$; in accordance with the range of service temperature taking into account additional influences of the process conditions ($T_{a,\min}$), ($T_{a,\max} + 20\text{ K}$).

Basic specification, Position 4 (Display, Operation) = N

Observe the requirements according to IEC/EN 60079-14 for conduit systems and the wiring- and installation instructions of the suitable Safety Instructions (XA). In addition, observe national regulations and standards for conduit systems.

Intrinsic safety

Ex ic

Basic specification, Position 1, 2 (Approval) = MH

- The device is only suitable for connection to certified, intrinsically safe equipment with explosion protection Ex ic.
- If the conditions $U_i > U_o$, ($I_i > I_o$), $C_a > C_i + C_{\text{cable}}$ and $L_a > L_i + L_{\text{cable}}$ are met, the energy-limited installation concept (Ex ic) allows energy-limited devices or associated energy-limited devices to be connected according to the entity concept.
- The intrinsically safe input power circuit of the device is isolated from ground. If the device is only equipped with one input, the dielectric strength of the input is at least $500\text{ V}_{\text{rms}}$. If the device is equipped with more than one input, the dielectric strength of each individual input to ground is at least $500\text{ V}_{\text{rms}}$, and the dielectric strength of the inputs vis-à-vis one another is also at least $500\text{ V}_{\text{rms}}$.
- Observe the pertinent guidelines when interconnecting intrinsically safe circuits.
- The device can be connected to the Endress+Hauser FXA291 service tool: refer to the Operating Instructions and specifications in the "Overvoltage protection" chapter.

Non-sparking

Ex nA

Basic specification, Position 1, 2 (Approval) = MG

In potentially explosive atmospheres:

- Do not disconnect electrical connections when energized.
- Do not connect the service tool (e.g. FXA291).

Basic specification, Position 5 (Housing) = A

The housing is not approved for Ex nA explosion protection.

Cable specification

Without *Optional specification, ID Nx, Ox (Accessory Mounted) = NA*
(Overvoltage protection Type OVP20)

<i>Basic specification, Position 3 (Power Supply, Output)</i>	Cross section connecting wire	Stripped insulation
A, B, C	0.5 to 2.5 mm ²	10 mm

With *Optional specification, ID Nx, Ox (Accessory Mounted) = NA*
(Overvoltage protection Type OVP20)

Basic specification, Position 3 (Power Supply, Output)	Cross section connecting wire	Tightening torque of terminal screw	Stripped insulation
A, B, C	0.2 to 2.5 mm ²	0.35 to 0.4 Nm	5 mm

Potential equalization

- Integrate the device into the local potential equalization.
- Grounding the screen, see the following figure.

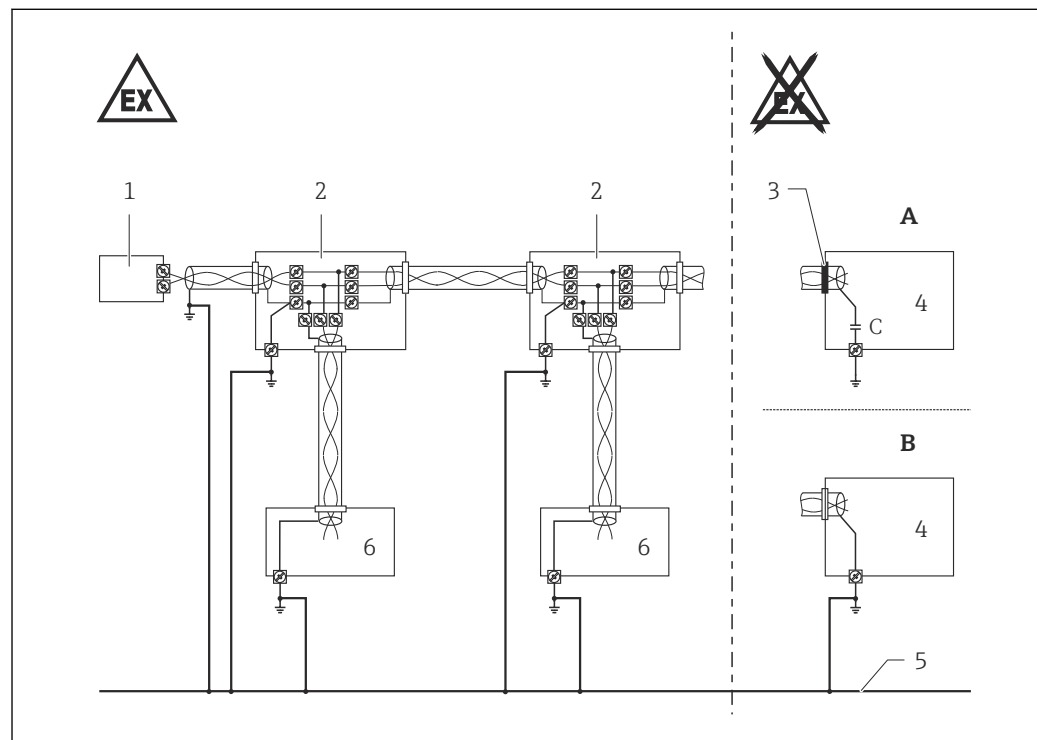

3

A Version 1: Use small capacitors (e.g. 1 nF, 1 500 V dielectric strength, ceramic).
Total capacitance connected to the screen may not exceed 10 nF.

B Version 2

1 Terminating resistor

2 Distributor/T box

3 Screen insulated

4 Supply unit/Segment coupler

5 Potential equalization (secured in high degree)

6 Field device

Overvoltage protection

- If an overvoltage protection against atmospheric over voltages is required: no other circuits may leave the housing during normal operation without additional measures.
- For installations which require overvoltage protection to comply with national regulations or standards, install the device using overvoltage protection (e.g. HAW56x from Endress+Hauser).
- Observe the safety instructions of the overvoltage protection.

Optional specification, ID Nx, Ox (Accessory Mounted) = NA (Overvoltage protection Type OVP20)

The intrinsically safe input power circuit of the device is isolated from ground. If the device is only equipped with one input, the dielectric strength of the input is at least 290 V_{rms}. If the device is equipped with more than one input, the dielectric strength of each individual input to ground is at least 290 V_{rms}, and the dielectric strength of the inputs vis-à-vis one another is also at least 290 V_{rms}.

Temperature tables →  16

Connection data

Cable entry: Connection compartment

Ex ic

Basic specification, Position 1, 2 (Approval) = MH

Not relevant.

Ex nA

Basic specification, Position 1, 2 (Approval) = MG

Cable gland: Basic specification, Position 6 (Electrical Connection) = A

Basic specification, Position 5 (Housing) = B, C

preferably for Position 5 (Housing) = B

Thread	Clamping range	Material	Sealing insert	O-ring
M20x1,5	ø 7 to 12 mm	1.4404	NBR	EPDM (ø 17x2)

preferably for Position 5 (Housing) = C

Thread	Clamping range	Material	Sealing insert	O-ring
M20x1,5	ø 8 to 10.5 mm ¹⁾ (ø 6.5 to 13 mm) ²⁾	Ms, nickel-plated	LSR (Silicone)	EPDM (ø 17x2)

- 1) Standard
- 2) Separate clamping inserts available

-  The tightening torque refers to cable glands installed by the manufacturer:
 - Recommended: 3.5 Nm
 - Maximum: 10 Nm
 - This value may be different depending on the type of cable. However, the maximum value must not be exceeded.
- Only suitable for fixed installation. The operator must pay attention to a suitable strain relief of the cable.
- The cable glands are suitable for a low risk of mechanical danger (4 Joule) and must be mounted in a protected position if larger impact energy levels are expected.
- To maintain the ingress protection of the housing: Install the housing cover, cable glands and blind plugs correctly.

Cable entry: Electronics compartment

Not relevant.

Terminals

Optional specification, ID Nx, Ox (Accessory Mounted) = NA (Overvoltage protection Type OVP20)

When using the internal overvoltage protection: No changes to the connection values.

Ex ic

Basic specification, Position 1, 2 (Approval) = MH

Power supply and signal circuit with protection type: intrinsic safety Ex ic IIC, Ex ic IIB.

Basic specification, Position 3 (Power Supply, Output) = E, G

Terminal 1 (+), 2 (-)		Terminal 3 (+), 4 (-)
FISCO	Entity	Switch output (PFS)
$U_i = 17.5 \text{ V}$	$U_i = 32 \text{ V}$	$U_i = 35 \text{ V}$ $I_i = 300 \text{ mA}$ $P_i = 1 \text{ W}$
$I_i = \text{not applicable}$ (current-controlled circuit)		
$P_i = \text{not applicable}$		
effective inner inductance $L_i = 10 \mu\text{H}$		effective inner inductance $L_i = 0$
effective inner capacitance $C_i = 5 \text{ nF}$		effective inner capacitance $C_i = 6 \text{ nF}$

Service interface (CDI)

Taking the following values into consideration, the device can be connected to the certified Endress+Hauser FXA291 service tool or a similar interface:

Service interface														
$U_i = 7.3 \text{ V}$ effective inner inductance $L_i = \text{negligible}$ effective inner capacitance $C_i = \text{negligible}$														
$U_o = 7.3 \text{ V}$ $I_o = 100 \text{ mA}$ $P_o = 160 \text{ mW}$														
$L_o \text{ (mH)} =$	5.00	2.00	1.00	0.50	0.20	0.15	0.10	0.05	0.02	0.01	0.005	0.002	0.001	
$C_o \text{ (}\mu\text{F)}^{1) =}$	0.73	1.20	1.60	2.00	2.60	-	3.20	4.00	5.50	7.30	10.00	12.70	12.70	
$C_o \text{ (}\mu\text{F)}^{2) =}$	-	0.49	0.90	1.40	-	2.00	-	-	-	-	-	-	-	

1) Values according to PTB "ispark" program

2) Values according to ABNT NBR IEC 60079-25, Annex C

Ex nA

Basic specification, Position 1, 2 (Approval) = MG

Power supply and signal circuit with protection type: not intrinsically safe.

Basic specification, Position 3 (Power Supply, Output) = E, G

The power consumption of I/O modules with passive PFS output can be limited for certain applications.

- Recommended: Power consumption = 1 W. This is obtained for a supply voltage at the terminals of 27 V_{DC} .
- For higher supply voltages (U_{max}): Insert a serial resistance (R_V) in order to limit the power consumption, see table below.

Table for the PFS serial resistance (R_V):

Power consumption	1.0 W
Total power consumption	1.88 W
Internal resistance R_i	760 Ω

U_{max} [V]	R_V min
35	205 Ω
34	177 Ω
33	150 Ω
32	122 Ω
31	95 Ω
30	67 Ω
29	39 Ω
28	12 Ω
27	0 Ω

 For values associated with a higher or lower internal power consumption please contact Endress+Hauser.

Terminal 1 (+), 2 (-)	Terminal 3 (+), 4 (-)
Power supply $U_N = 32 V_{DC}$ $U_m = 250 V$	Switch output (PFS) $U_N = 35 V_{DC}$ $U_m = 250 V$

Service interface (CDI)

Without: *Basic specification, Position 4 (Display, Operation) = L, M, N*

Taking the following values into consideration, the device can be connected to the Endress+Hauser FXA291 service tool or a similar interface:

Service interface
$U_N = 6.5 V$

In connection with: *Basic specification, Position 4 (Display, Operation) = L, M, N*

Taking the following values into consideration, the device can be connected to the certified Endress+Hauser FXA291 service tool or a similar interface:

Service interface														
$U_i = 7.3 V$ effective inner inductance $L_i =$ negligible effective inner capacitance $C_i =$ negligible														
$U_o = 7.3 V$ $I_o = 100 mA$ $P_o = 160 mW$														
L_o (mH) =	5.00	2.00	1.00	0.50	0.20	0.15	0.10	0.05	0.02	0.01	0.005	0.002	0.001	
C_o (μF) ¹⁾ =	0.73	1.20	1.60	2.00	2.60	-	3.20	4.00	5.50	7.30	10.00	12.70	12.70	
C_o (μF) ²⁾ =	-	0.49	0.90	1.40	-	2.00	-	-	-	-	-	-	-	

- 1) Values according to PTB "ispark" program
- 2) Values according to ABNT NBR IEC 60079-25, Annex C

Levelflex FMP50/51/52/53/54/55/56/57

PROFIBUS PA, FOUNDATION Fieldbus

Table of contents

Notes on the structure	16
Example diagrams of possible deratings	18
Zone 2: Compact; 1 channel	19
Zone 2: Compact; 2 channels	29
Zone 2: Remote; 1 channel	39
Zone 2: Remote; 2 channels	40

Notes on the structure

Extract from the extended order code

Device type

FMP50, FMP51, FMP52, FMP53, FMP54, FMP55, FMP56, FMP57

Basic specifications

Position 1, 2 (Approval)		
Selected option		Description
FMP5x	MG ¹⁾	INMETRO Ex nA IIC T6...T1 Gc
	MH ²⁾	INMETRO Ex ic IIC T6...T1 Gc

- 1) The designation changes in connection with Position 4 (Display, Operation) = L, M, N:
Ex nA [ia Ga] IIC T6...T1 Gc
- 2) The designation changes in connection with Position 4 (Display, Operation) = L, M, N:
Ex ic [ia Ga] IIC T6...T1 Gc

Position 3 (Power Supply, Output)		
Selected option		Description
FMP5x	E	2-wire, FOUNDATION Fieldbus, switch output (PFS)
	G	2-wire, PROFIBUS PA, switch output (PFS)

Position 5 (Housing)		
Selected option		Description
FMP5x	A ¹⁾	GT19 dual compartment, plastics PBT
	C	GT20 dual compartment, Alu coated
FMP51 FMP52 FMP54-57	B	GT18 dual compartment, 316L

- 1) Only in connection with Position 1, 2 (Approval) = MH

Position 9, 10 (Seal)		
Selected option		Description
FMP50	A1	Viton, -20...80 °C
FMP51	A4	Viton, -30...150 °C
	B3	EPDM, -40...120 °C
	C3	Kalrez, -20...200 °C
	E1	FVMQ, -50...150 °C
FMP53	AD	FKM, FDA, USP Cl. VI, -10...150 °C
	B5	EPDM, FDA, USP Cl. VI, -20...130 °C
	C4	Kalrez, FDA, USP Cl. VI, -20...150 °C
FMP54	D1	Graphite, -196...280 °C (XT)
	D2	Graphite, -196...450 °C (HT)
FMP56	AB	Viton, -30...120 °C
	B3	EPDM, -40...120 °C

Position 9, 10 (Seal)		
Selected option		Description
FMP57	A4	Viton, -30...150 °C
	B3	EPDM, -40...120 °C
	C5	Kalrez, -5...185 °C

 Shown in the temperature tables exemplary as follows:

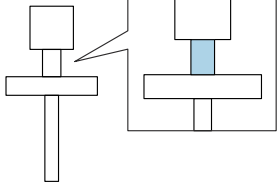





Optional specifications

ID Jx (Test; Certificate)		
Selected option		Description
FMP51 ¹⁾ FMP54	JN ²⁾	Ambient temperature transmitter -50 °C

- 1) Only in connection with Position 9, 10 (Seal) = E1
- 2) Only in connection with Position 1, 2 (Approval) = MH and Position 5 (Housing) = B, C

ID Mx (Probe Design)		
Selected option		Description
FMP5x	MB	Sensor remote, 3 m/9 ft cable, detachable + mounting bracket
FMP53	MA	Sensor compact, detachable
FMP50-54	MC	Sensor remote, 6 m/18 ft cable, detachable + mounting bracket
FMP56 FMP57	MD	Sensor remote, 9 m/27 ft cable, detachable + mounting bracket

General notes

-  *Optional specification, ID Nx (Accessory Mounted) = NA (Overvoltage protection type OVP20)*
When using the internal overvoltage protection: Reduce the admissible ambient temperature at the housing by 5 K.
Basic specification, Position 5 (Housing) = A
When using the remote display FHX50: Reduce the admissible ambient temperature at the housing by 3 K.
-  Observe the permitted temperature range at the probe.
-  *Basic specification, Position 1, 2 (Approval) = MG in connection with Basic specification, Position 3 (Power Supply, Output) = E, G*
Deratings are based on a power consumption of 1 W (PFS); →  12.

Description notes

i Unless otherwise indicated, the positions always refer to the basic specification.

1st column: Position 5 (Housing) = A, B, ...

2nd column: Position 3 (Power Supply, Output) = A, B, ..

- (1): 1 channel used
- (2): 2 channels used

3rd column: Temperature classes T6 (85 °C) to T1 (450 °C)

Column P1 to P6: Position (temperature value) on the axes of the derating

- T_a : Ambient temperature in °C
- T_p : Process temperature in °C

i Column P6 is only relevant for version B of the derating.

→ 18

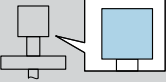
 = C	(1)	P1		P2		P3		P4		P5		P6		
		T_p	T_a	T_p	T_a	T_p	T_a	T_p	T_a	T_p	T_a	T_p	T_a	
	E, G	T6	-40	60	60	60	85	53	85	-40	-40	-40	-	-
		T5	-40	75	75	75	100	68	100	-40	-40	-40	-	-
		T4	-40	80	80	80	135	67	135	-40	-40	-40	-	-
		T3	-40	80	80	80	200	51	200	-40	-40	-40	-	-

A0038026-EN

Example diagrams of possible deratings

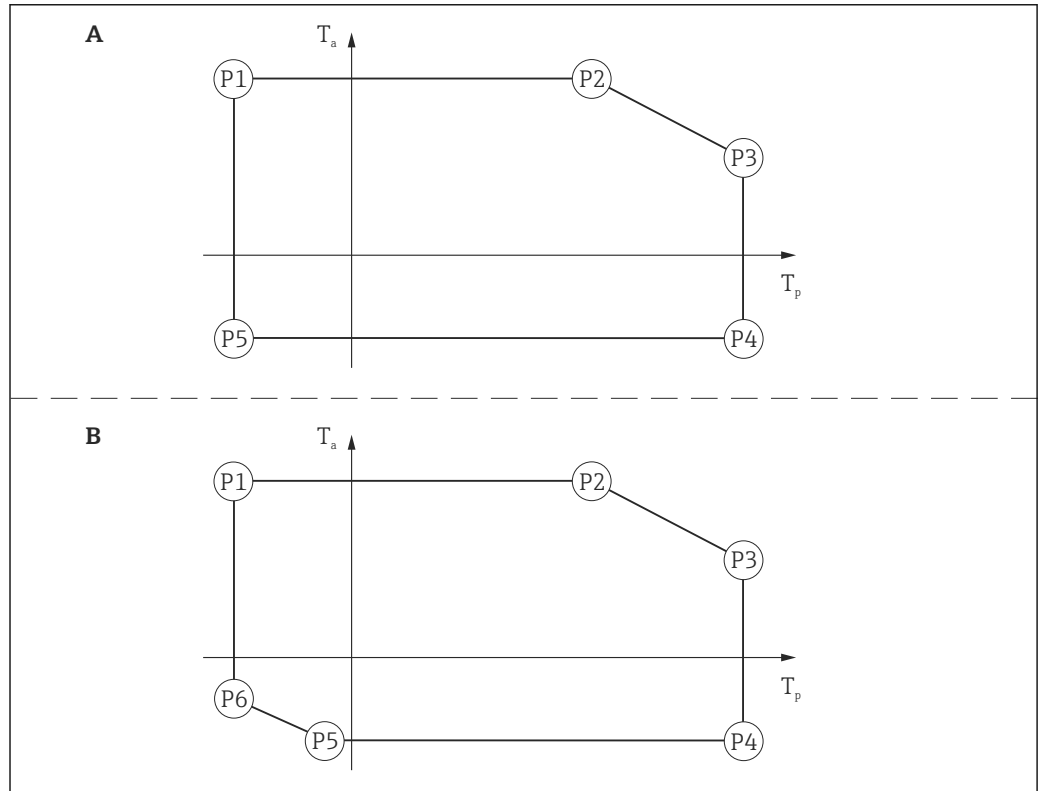

A0022717

 4

Zone 2: Compact; 1 channel

Probe design: compact

Position 3 (Power Supply, Output) = E, G: 1 channel used

Page references to the temperature tables of the respective device types: See the following list.

- FMP50 → 19
- FMP51 → 20
- FMP52 → 21
- FMP53 → 22
- FMP54 → 23
- FMP55 → 26
- FMP56 → 27
- FMP57 → 28

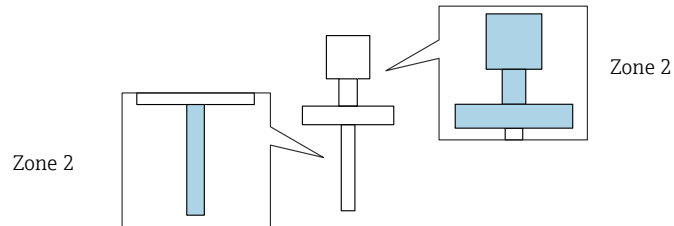

FMP50

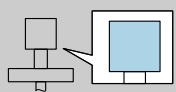
 = A	(1)		P1		P2		P3		P4		P5		P6	
			T _p	T _a	T _p	T _a	T _p	T _a	T _p	T _a	T _p	T _a	T _p	T _a
	E, G	T6	-20	60	60	60	80	53	80	-20	-20	-20	-	-

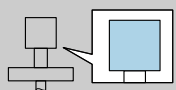
 = C	(1)		P1		P2		P3		P4		P5		P6	
			T _p	T _a	T _p	T _a	T _p	T _a	T _p	T _a	T _p	T _a	T _p	T _a
	E, G	T6	-20	60	60	60	80	56	80	-20	-20	-20	-	-

FMP51

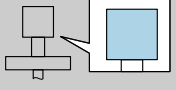
 = A	(1)	P1		P2		P3		P4		P5		P6		
		T _p	T _a	T _p	T _a	T _p	T _a	T _p	T _a	T _p	T _a	T _p	T _a	
	E, G	T6	-40	60	60	60	85	45	85	-40	-40	-40	-	-
		T5	-40	73	73	73	100	60	100	-40	-40	-40	-	-
		T4	-40	73	73	73	135	54	135	-40	-40	-40	-	-

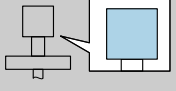
 = B	(1)	P1		P2		P3		P4		P5		P6		
		T _p	T _a	T _p	T _a	T _p	T _a	T _p	T _a	T _p	T _a	T _p	T _a	
	E, G	T6	-40 -50 ¹⁾	60	60	60	85	51	85	-40 -50 ¹⁾	-40 -50 ¹⁾	-40 -50 ¹⁾	-	-
		T5	-40 -50 ¹⁾	75	75	75	100	66	100	-40 -50 ¹⁾	-40 -50 ¹⁾	-40 -50 ¹⁾	-	-
		T4	-40 -50 ¹⁾	80	80	80	135	67	135	-40 -50 ¹⁾	-40 -50 ¹⁾	-40 -50 ¹⁾	-	-
		T3	-40 -50 ¹⁾	80	80	80	200	48	200	-40 -50 ¹⁾	-40 -50 ¹⁾	-40 -50 ¹⁾	-	-

1) Only in connection with Optional specification, ID Jx (Test, Certificate) = JN

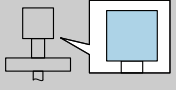
 = C	(1)	P1		P2		P3		P4		P5		P6		
		T _p	T _a	T _p	T _a	T _p	T _a	T _p	T _a	T _p	T _a	T _p	T _a	
	E, G	T6	-40 -50 ¹⁾	60	60	60	85	53	85	-40 -50 ¹⁾	-40 -50 ¹⁾	-40 -50 ¹⁾	-	-
		T5	-40 -50 ¹⁾	75	75	75	100	68	100	-40 -50 ¹⁾	-40 -50 ¹⁾	-40 -50 ¹⁾	-	-
		T4	-40 -50 ¹⁾	80	80	80	135	69	135	-40 -50 ¹⁾	-40 -50 ¹⁾	-40 -50 ¹⁾	-	-
		T3	-40 -50 ¹⁾	80	80	80	200	56	200	-40 -50 ¹⁾	-40 -50 ¹⁾	-40 -50 ¹⁾	-	-

1) Only in connection with Optional specification, ID Jx (Test, Certificate) = JN

FMP52

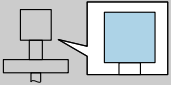
 = A	(1)		P1		P2		P3		P4		P5		P6	
			T _p	T _a	T _p	T _a	T _p	T _a	T _p	T _a	T _p	T _a	T _p	T _a
	E, G	T6	-50	60	60	60	85	49	85	-40	-40	-40	-50	-35
		T5	-50	73	73	73	100	64	100	-40	-40	-40	-50	-35
		T4	-50	73	73	73	135	58	135	-40	-40	-40	-50	-35
		T3	-50	73	73	73	200	37	200	-40	-40	-40	-50	-35

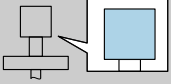
 = B	(1)		P1		P2		P3		P4		P5		P6	
			T _p	T _a	T _p	T _a	T _p	T _a	T _p	T _a	T _p	T _a	T _p	T _a
	E, G	T6	-50	60	60	60	85	52	85	-40	-40	-40	-50	-37
		T5	-50	75	75	75	100	67	100	-40	-40	-40	-50	-37
		T4	-50	80	80	80	135	68	135	-40	-40	-40	-50	-37
		T3	-50	80	80	80	200	52	200	-40	-40	-40	-50	-37

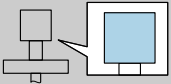
 = C	(1)		P1		P2		P3		P4		P5		P6	
			T _p	T _a	T _p	T _a	T _p	T _a	T _p	T _a	T _p	T _a	T _p	T _a
	E, G	T6	-50	60	60	60	85	54	85	-40	-40	-40	-50	-37
		T5	-50	75	75	75	100	69	100	-40	-40	-40	-50	-37
		T4	-50	80	80	80	135	70	135	-40	-40	-40	-50	-37
		T3	-50	80	80	80	200	58	200	-40	-40	-40	-50	-37

FMP53

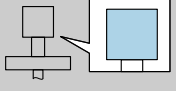
 = A	(1)	P1		P2		P3		P4		P5		P6		
		T _p	T _a	T _p	T _a	T _p	T _a	T _p	T _a	T _p	T _a	T _p	T _a	
	E, G	T6	-20	60	60	60	85	47	85	-20	-20	-20	-	-
		T5	-20	73	73	73	100	62	100	-20	-20	-20	-	-
		T4	-20	73	73	73	135	56	135	-20	-20	-20	-	-
		T3 ¹⁾	-20	73	73	73	150	52	150	-20	-20	-20	-	-

1) Functional: Maximum permissible process temperature

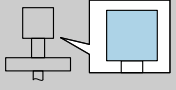
 = C	(1)	P1		P2		P3		P4		P5		P6		
		T _p	T _a	T _p	T _a	T _p	T _a	T _p	T _a	T _p	T _a	T _p	T _a	
	E, G	T6	-20	60	60	60	85	54	85	-20	-20	-20	-	-
		T5	-20	75	75	75	100	69	100	-20	-20	-20	-	-
		T4	-20	80	80	80	135	69	135	-20	-20	-20	-	-
		T3 ¹⁾	-20	80	80	80	150	66	150	-20	-20	-20	-	-

1) Functional: Maximum permissible process temperature

FMP54

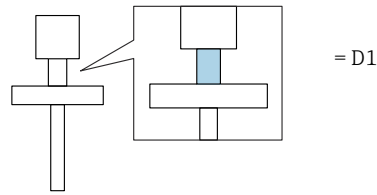

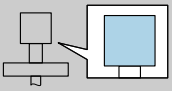
 = A	(1)	P1		P2		P3		P4		P5		P6		
		T _p	T _a	T _p	T _a	T _p	T _a	T _p	T _a	T _p	T _a	T _p	T _a	
	E, G	T6	-196	58	58	58	85	53	85	-40	-40	-40	-196	-5
		T5	-196	73	73	73	100	68	100	-40	-40	-40	-196	-5
		T4	-196	73	73	73	135	64	135	-40	-40	-40	-196	-5
		T3	-196	73	73	73	200	54	200	-40	-40	-40	-196	-5
		T2 ¹⁾	-196	73	73	73	280	41	280	-40	-40	-40	-196	-5

1) Functional: Maximum permissible process temperature

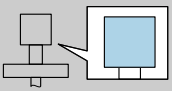
 = B	(1)	P1		P2		P3		P4		P5		P6		
		T _p	T _a	T _p	T _a	T _p	T _a	T _p	T _a	T _p	T _a	T _p	T _a	
	E, G	T6	-196	60	60	60	85	56	85	-40 -50 ¹⁾	-40 -50 ¹⁾	-40 -50 ¹⁾	-196	-16 -27 ¹⁾
		T5	-196	75	75	75	100	71	100	-40 -50 ¹⁾	-40 -50 ¹⁾	-40 -50 ¹⁾	-196	-16 -27 ¹⁾
		T4	-196	80	80	80	135	73	135	-40 -50 ¹⁾	-40 -50 ¹⁾	-40 -50 ¹⁾	-196	-16 -27 ¹⁾
		T3	-196	80	80	80	200	64	200	-40 -50 ¹⁾	-40 -50 ¹⁾	-40 -50 ¹⁾	-196	-16 -27 ¹⁾
		T2 ²⁾	-196	80	80	80	280	54	280	-40 -50 ¹⁾	-40 -50 ¹⁾	-40 -50 ¹⁾	-196	-16 -27 ¹⁾

1) Only in connection with Optional specification, ID Jx (Test, Certificate) = JN

2) Functional: Maximum permissible process temperature

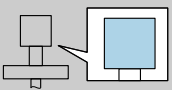
 = C	(1)	P1		P2		P3		P4		P5		P6		
		T _p	T _a	T _p	T _a	T _p	T _a	T _p	T _a	T _p	T _a	T _p	T _a	
	E, G	T6	-196	60	60	60	85	57	85	-40 -50 ¹⁾	-40 -50 ¹⁾	-40 -50 ¹⁾	-196	-23 -34 ¹⁾
		T5	-196	75	75	75	100	72	100	-40 -50 ¹⁾	-40 -50 ¹⁾	-40 -50 ¹⁾	-196	-23 -34 ¹⁾
		T4	-196	80	80	80	135	75	135	-40 -50 ¹⁾	-40 -50 ¹⁾	-40 -50 ¹⁾	-196	-23 -34 ¹⁾
		T3	-196	80	80	80	200	68	200	-40 -50 ¹⁾	-40 -50 ¹⁾	-40 -50 ¹⁾	-196	-23 -34 ¹⁾
		T2 ²⁾	-196	80	80	80	280	60	280	-40 -50 ¹⁾	-40 -50 ¹⁾	-40 -50 ¹⁾	-196	-23 -34 ¹⁾

1) Only in connection with Optional specification, ID Jx (Test, Certificate) = JN

2) Functional: Maximum permissible process temperature

FMP54

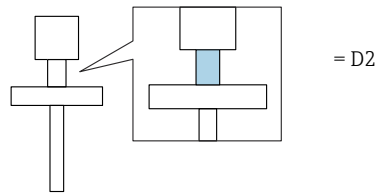

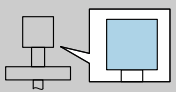
 = A	(1)	P1		P2		P3		P4		P5		P6		
		T _p	T _a	T _p	T _a	T _p	T _a	T _p	T _a	T _p	T _a	T _p	T _a	
	E, G	T6	-196	58	58	58	85	55	85	-40	-40	-40	-196	-21
		T5	-196	73	73	73	100	70	100	-40	-40	-40	-196	-21
		T4	-196	73	73	73	135	67	135	-40	-40	-40	-196	-21
		T3	-196	73	73	73	200	61	200	-40	-40	-40	-196	-21
		T2	-196	73	73	73	300	51	300	-40	-40	-40	-196	-21
		T1	-196	73	73	73	450	37	450	-40	-40	-40	-196	-21

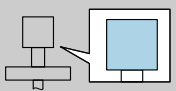
 = B	(1)	P1		P2		P3		P4		P5		P6		
		T _p	T _a	T _p	T _a	T _p	T _a	T _p	T _a	T _p	T _a	T _p	T _a	
	E, G	T6	-196	60	60	60	85	57	85	-40 -50 ¹⁾	-40 -50 ¹⁾	-40 -50 ¹⁾	-196	-26 -37 ¹⁾
		T5	-196	75	75	75	100	72	100	-40 -50 ¹⁾	-40 -50 ¹⁾	-40 -50 ¹⁾	-196	-26 -37 ¹⁾
		T4	-196	80	80	80	135	76	135	-40 -50 ¹⁾	-40 -50 ¹⁾	-40 -50 ¹⁾	-196	-26 -37 ¹⁾
		T3	-196	80	80	80	200	71	200	-40 -50 ¹⁾	-40 -50 ¹⁾	-40 -50 ¹⁾	-196	-26 -37 ¹⁾
		T2	-196	80	80	80	300	64	300	-40 -50 ¹⁾	-40 -50 ¹⁾	-40 -50 ¹⁾	-196	-26 -37 ¹⁾
		T1	-196	80	80	80	450	52	450	-40 -50 ¹⁾	-40 -50 ¹⁾	-40 -50 ¹⁾	-196	-26 -37 ¹⁾

1) Only in connection with Optional specification, ID Jx (Test, Certificate) = JN

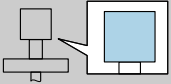
 = C	(1)	P1		P2		P3		P4		P5		P6		
		T _p	T _a	T _p	T _a	T _p	T _a	T _p	T _a	T _p	T _a	T _p	T _a	
	E, G	T6	-196	60	60	60	85	58	85	-40 -50 ¹⁾	-40 -50 ¹⁾	-40 -50 ¹⁾	-196	-27 -38 ¹⁾
		T5	-196	75	75	75	100	73	100	-40 -50 ¹⁾	-40 -50 ¹⁾	-40 -50 ¹⁾	-196	-27 -38 ¹⁾
		T4	-196	80	80	80	135	76	135	-40 -50 ¹⁾	-40 -50 ¹⁾	-40 -50 ¹⁾	-196	-27 -38 ¹⁾
		T3	-196	80	80	80	200	72	200	-40 -50 ¹⁾	-40 -50 ¹⁾	-40 -50 ¹⁾	-196	-27 -38 ¹⁾
		T2	-196	80	80	80	300	65	300	-40 -50 ¹⁾	-40 -50 ¹⁾	-40 -50 ¹⁾	-196	-27 -38 ¹⁾
		T1	-196	80	80	80	450	54	450	-40 -50 ¹⁾	-40 -50 ¹⁾	-40 -50 ¹⁾	-196	-27 -38 ¹⁾

1) Only in connection with Optional specification, ID Jx (Test, Certificate) = JN

FMP55

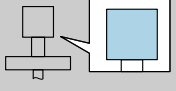
 = A	(1)	P1		P2		P3		P4		P5		P6		
		T _p	T _a	T _p	T _a	T _p	T _a	T _p	T _a	T _p	T _a	T _p	T _a	
	E, G	T6	-50	58	58	58	85	49	85	-40	-40	-40	-50	-35
		T5	-50	73	73	73	100	64	100	-40	-40	-40	-50	-35
		T4	-50	73	73	73	135	55	135	-40	-40	-40	-50	-35
		T3	-50	73	73	73	200	36	200	-40	-40	-40	-50	-35

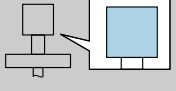
 = B	(1)	P1		P2		P3		P4		P5		P6		
		T _p	T _a	T _p	T _a	T _p	T _a	T _p	T _a	T _p	T _a	T _p	T _a	
	E, G	T6	-50	60	60	60	85	52	85	-40	-40	-40	-50	-37
		T5	-50	75	75	75	100	67	100	-40	-40	-40	-50	-37
		T4	-50	80	80	80	135	68	135	-40	-40	-40	-50	-37
		T3	-50	80	80	80	200	52	200	-40	-40	-40	-50	-37

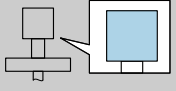
 = C	(1)	P1		P2		P3		P4		P5		P6		
		T _p	T _a	T _p	T _a	T _p	T _a	T _p	T _a	T _p	T _a	T _p	T _a	
	E, G	T6	-50	60	60	60	85	54	85	-40	-40	-40	-50	-37
		T5	-50	75	75	75	100	69	100	-40	-40	-40	-50	-37
		T4	-50	80	80	80	135	69	135	-40	-40	-40	-50	-37
		T3	-50	80	80	80	200	57	200	-40	-40	-40	-50	-37

FMP56

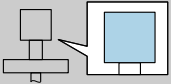
 = A	(1)		P1		P2		P3		P4		P5		P6	
			T _p	T _a	T _p	T _a	T _p	T _a	T _p	T _a	T _p	T _a	T _p	T _a
	E, G	T6	-40	60	60	60	85	47	85	-40	-40	-40	-	-
		T5	-40	73	73	73	100	62	100	-40	-40	-40	-	-
		T4 ¹⁾	-40	73	73	73	120	58	120	-40	-40	-40	-	-

1) Functional: Maximum permissible process temperature

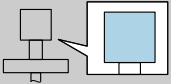
 = B	(1)		P1		P2		P3		P4		P5		P6	
			T _p	T _a	T _p	T _a	T _p	T _a	T _p	T _a	T _p	T _a	T _p	T _a
	E, G	T6	-40	60	60	60	85	51	85	-40	-40	-40	-	-
		T5	-40	75	75	75	100	66	100	-40	-40	-40	-	-
		T4 ¹⁾	-40	80	80	80	120	71	120	-40	-40	-40	-	-

1) Functional: Maximum permissible process temperature

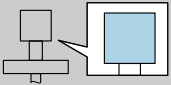
 = C	(1)		P1		P2		P3		P4		P5		P6	
			T _p	T _a	T _p	T _a	T _p	T _a	T _p	T _a	T _p	T _a	T _p	T _a
	E, G	T6	-40	60	60	60	85	54	85	-40	-40	-40	-	-
		T5	-40	75	75	75	100	69	100	-40	-40	-40	-	-
		T4 ¹⁾	-40	80	80	80	120	72	120	-40	-40	-40	-	-

1) Functional: Maximum permissible process temperature

FMP57

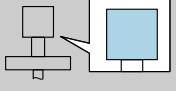
 = A	(1)	P1		P2		P3		P4		P5		P6		
		T _p	T _a	T _p	T _a	T _p	T _a	T _p	T _a	T _p	T _a	T _p	T _a	
	E, G	T6	-40	60	60	60	85	49	85	-40	-40	-40	-	-
		T5	-40	73	73	73	100	64	100	-40	-40	-40	-	-
		T4	-40	73	73	73	135	58	135	-40	-40	-40	-	-
		T3 ¹⁾	-40	73	73	73	185	42	185	-40	-40	-40	-	-

1) Functional: Maximum permissible process temperature

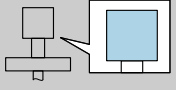
 = B	(1)	P1		P2		P3		P4		P5		P6		
		T _p	T _a	T _p	T _a	T _p	T _a	T _p	T _a	T _p	T _a	T _p	T _a	
	E, G	T6	-40	60	60	60	85	53	85	-40	-40	-40	-	-
		T5	-40	75	75	75	100	68	100	-40	-40	-40	-	-
		T4	-40	80	80	80	135	69	135	-40	-40	-40	-	-
		T3 ¹⁾	-40	80	80	80	185	60	185	-40	-40	-40	-	-

1) Functional: Maximum permissible process temperature

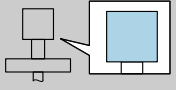
 = C	(1)	P1		P2		P3		P4		P5		P6		
		T _p	T _a	T _p	T _a	T _p	T _a	T _p	T _a	T _p	T _a	T _p	T _a	
	E, G	T6	-40	60	60	60	85	55	85	-40	-40	-40	-	-
		T5	-40	75	75	75	100	70	100	-40	-40	-40	-	-
		T4	-40	80	80	80	135	71	135	-40	-40	-40	-	-
		T3 ¹⁾	-40	80	80	80	185	64	185	-40	-40	-40	-	-

1) Functional: Maximum permissible process temperature

Zone 2: Compact; 2 channels

Probe design: compact

Position 3 (Power Supply, Output) = E, G: 2 channels used

Page references to the temperature tables of the respective device types: See the following list.

- FMP50 → 29
- FMP51 → 30
- FMP52 → 31
- FMP53 → 32
- FMP54 → 33
- FMP55 → 36
- FMP56 → 37
- FMP57 → 38

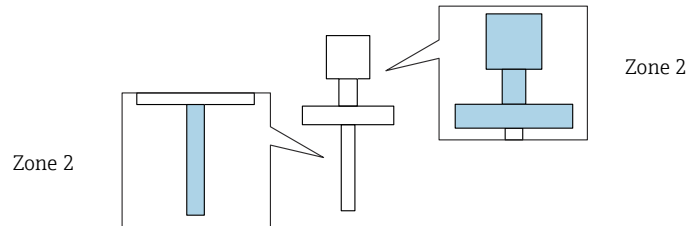

FMP50

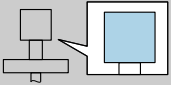
 = A	(2)	T6	P1		P2		P3		P4		P5		P6	
			T _p	T _a	T _p	T _a	T _p	T _a	T _p	T _a	T _p	T _a	T _p	T _a
E, G		T6	-20	51	51	51	80	46	80	-20	-20	-20	-	-

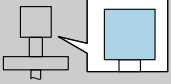
 = C	(2)	T6	P1		P2		P3		P4		P5		P6	
			T _p	T _a	T _p	T _a	T _p	T _a	T _p	T _a	T _p	T _a	T _p	T _a
E, G		T6	-20	60	60	60	80	56	80	-20	-20	-20	-	-

FMP51

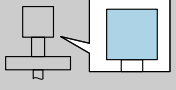
 = A	(2)	P1		P2		P3		P4		P5		P6		
		T _p	T _a	T _p	T _a	T _p	T _a	T _p	T _a	T _p	T _a	T _p	T _a	
	E, G	T6	-40	51	51	51	85	40	85	-40	-40	-40	-	-
		T5	-40	56	56	56	100	42	100	-40	-40	-40	-	-
		T4	-40	56	56	56	135	31	135	-40	-40	-40	-	-

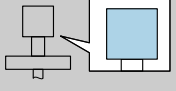
 = B	(2)	P1		P2		P3		P4		P5		P6		
		T _p	T _a	T _p	T _a	T _p	T _a	T _p	T _a	T _p	T _a	T _p	T _a	
	E, G	T6	-40 -50 ¹⁾	60	60	60	85	51	85	-40 -50 ¹⁾	-40 -50 ¹⁾	-40 -50 ¹⁾	-	-
		T5	-40 -50 ¹⁾	75	75	75	100	66	100	-40 -50 ¹⁾	-40 -50 ¹⁾	-40 -50 ¹⁾	-	-
		T4	-40 -50 ¹⁾	75	75	75	135	61	135	-40 -50 ¹⁾	-40 -50 ¹⁾	-40 -50 ¹⁾	-	-
		T3	-40 -50 ¹⁾	75	75	75	200	45	200	-40 -50 ¹⁾	-40 -50 ¹⁾	-40 -50 ¹⁾	-	-

1) Only in connection with Optional specification, ID Jx (Test, Certificate) = JN

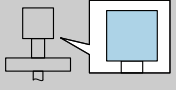
 = C	(2)	P1		P2		P3		P4		P5		P6		
		T _p	T _a	T _p	T _a	T _p	T _a	T _p	T _a	T _p	T _a	T _p	T _a	
	E, G	T6	-40 -50 ¹⁾	60	60	60	85	53	85	-40 -50 ¹⁾	-40 -50 ¹⁾	-40 -50 ¹⁾	-	-
		T5	-40 -50 ¹⁾	75	75	75	100	68	100	-40 -50 ¹⁾	-40 -50 ¹⁾	-40 -50 ¹⁾	-	-
		T4	-40 -50 ¹⁾	75	75	75	135	63	135	-40 -50 ¹⁾	-40 -50 ¹⁾	-40 -50 ¹⁾	-	-
		T3	-40 -50 ¹⁾	75	75	75	200	50	200	-40 -50 ¹⁾	-40 -50 ¹⁾	-40 -50 ¹⁾	-	-

1) Only in connection with Optional specification, ID Jx (Test, Certificate) = JN

FMP52

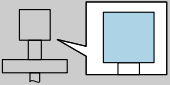
 = A	(2)		P1		P2		P3		P4		P5		P6	
			T _p	T _a	T _p	T _a	T _p	T _a	T _p	T _a	T _p	T _a	T _p	T _a
	E, G	T6	-50	51	51	51	85	51	85	-40	-40	-40	-50	-35
		T5	-50	56	56	56	100	56	100	-40	-40	-40	-50	-35
		T4	-50	56	56	56	135	56	135	-40	-40	-40	-50	-35
		T3	-50	56	56	56	200	56	200	-40	-40	-40	-50	-35

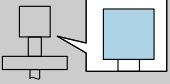
 = B	(2)		P1		P2		P3		P4		P5		P6	
			T _p	T _a	T _p	T _a	T _p	T _a	T _p	T _a	T _p	T _a	T _p	T _a
	E, G	T6	-50	60	60	60	85	52	85	-40	-40	-40	-50	-37
		T5	-50	75	75	75	100	67	100	-40	-40	-40	-50	-37
		T4	-50	75	75	75	135	62	135	-40	-40	-40	-50	-37
		T3	-50	75	75	75	200	47	200	-40	-40	-40	-50	-37

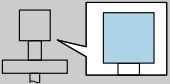
 = C	(2)		P1		P2		P3		P4		P5		P6	
			T _p	T _a	T _p	T _a	T _p	T _a	T _p	T _a	T _p	T _a	T _p	T _a
	E, G	T6	-50	60	60	60	85	54	85	-40	-40	-40	-50	-37
		T5	-50	75	75	75	100	69	100	-40	-40	-40	-50	-37
		T4	-50	75	75	75	135	64	135	-40	-40	-40	-50	-37
		T3	-50	75	75	75	200	52	200	-40	-40	-40	-50	-37

FMP53

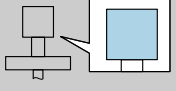
 = A	(2)	P1		P2		P3		P4		P5		P6		
		T _p	T _a	T _p	T _a	T _p	T _a	T _p	T _a	T _p	T _a	T _p	T _a	
	E, G	T6	-20	51	51	51	85	41	85	-20	-20	-20	-	-
		T5	-20	56	56	56	100	43	100	-20	-20	-20	-	-
		T4	-20	56	56	56	135	34	135	-20	-20	-20	-	-
		T3 ¹⁾	-20	56	56	56	150	30	150	-20	-20	-20	-	-

1) Functional: Maximum permissible process temperature

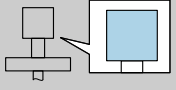
 = C	(2)	P1		P2		P3		P4		P5		P6		
		T _p	T _a	T _p	T _a	T _p	T _a	T _p	T _a	T _p	T _a	T _p	T _a	
	E, G	T6	-20	60	60	60	85	54	85	-20	-20	-20	-	-
		T5	-20	75	75	75	100	69	100	-20	-20	-20	-	-
		T4	-20	75	75	75	135	63	135	-20	-20	-20	-	-
		T3 ¹⁾	-20	75	75	75	150	60	150	-20	-20	-20	-	-

1) Functional: Maximum permissible process temperature

FMP54

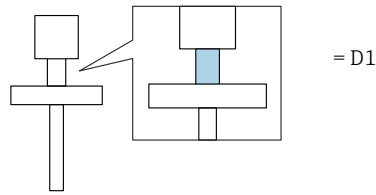

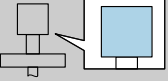
 = A	(2)	P1		P2		P3		P4		P5		P6		
		T _p	T _a	T _p	T _a	T _p	T _a	T _p	T _a	T _p	T _a	T _p	T _a	
	E, G	T6	-196	51	51	51	85	45	85	-40	-40	-40	-196	-5
		T5	-196	56	56	56	100	49	100	-40	-40	-40	-196	-5
		T4	-196	56	56	56	135	44	135	-40	-40	-40	-196	-5
		T3	-196	56	56	56	200	34	200	-40	-40	-40	-196	-5

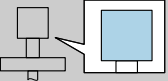
 = B	(2)	P1		P2		P3		P4		P5		P6		
		T _p	T _a	T _p	T _a	T _p	T _a	T _p	T _a	T _p	T _a	T _p	T _a	
	E, G	T6	-196	60	60	60	85	56	85	-40 -50 ¹⁾	-40 -50 ¹⁾	-40 -50 ¹⁾	-196	-16 -27 ¹⁾
		T5	-196	75	75	75	100	71	100	-40 -50 ¹⁾	-40 -50 ¹⁾	-40 -50 ¹⁾	-196	-16 -27 ¹⁾
		T4	-196	75	75	75	135	67	135	-40 -50 ¹⁾	-40 -50 ¹⁾	-40 -50 ¹⁾	-196	-16 -27 ¹⁾
		T3	-196	75	75	75	200	59	200	-40 -50 ¹⁾	-40 -50 ¹⁾	-40 -50 ¹⁾	-196	-16 -27 ¹⁾
		T2 ²⁾	-196	75	75	75	280	48	280	-40 -50 ¹⁾	-40 -50 ¹⁾	-40 -50 ¹⁾	-196	-16 -27 ¹⁾

- 1) Only in connection with Optional specification, ID Jx (Test, Certificate) = JN
- 2) Functional: Maximum permissible process temperature

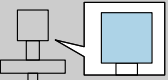
 = C	(2)	P1		P2		P3		P4		P5		P6		
		T _p	T _a	T _p	T _a	T _p	T _a	T _p	T _a	T _p	T _a	T _p	T _a	
	E, G	T6	-196	60	60	60	85	57	85	-40 -50 ¹⁾	-40 -50 ¹⁾	-40 -50 ¹⁾	-196	-23 -34 ¹⁾
		T5	-196	75	75	75	100	72	100	-40 -50 ¹⁾	-40 -50 ¹⁾	-40 -50 ¹⁾	-196	-23 -34 ¹⁾
		T4	-196	75	75	75	135	69	135	-40 -50 ¹⁾	-40 -50 ¹⁾	-40 -50 ¹⁾	-196	-23 -34 ¹⁾
		T3	-196	75	75	75	200	63	200	-40 -50 ¹⁾	-40 -50 ¹⁾	-40 -50 ¹⁾	-196	-23 -34 ¹⁾
		T2 ²⁾	-196	75	75	75	280	55	280	-40 -50 ¹⁾	-40 -50 ¹⁾	-40 -50 ¹⁾	-196	-23 -34 ¹⁾

- 1) Only in connection with Optional specification, ID Jx (Test, Certificate) = JN
- 2) Functional: Maximum permissible process temperature

FMP54

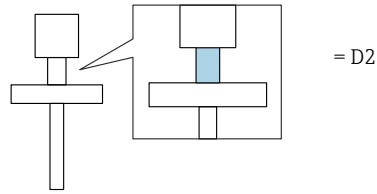

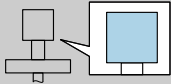
 = A	(2)	P1		P2		P3		P4		P5		P6		
		T _p	T _a	T _p	T _a	T _p	T _a	T _p	T _a	T _p	T _a	T _p	T _a	
	E, G	T6	-196	51	51	51	85	47	85	-40	-40	-40	-196	-21
		T5	-196	56	56	56	100	52	100	-40	-40	-40	-196	-21
		T4	-196	56	56	56	135	48	135	-40	-40	-40	-196	-21
		T3	-196	56	56	56	200	42	200	-40	-40	-40	-196	-21
		T2	-196	56	56	56	300	32	300	-40	-40	-40	-196	-21

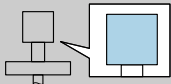
 = B	(2)	P1		P2		P3		P4		P5		P6		
		T _p	T _a	T _p	T _a	T _p	T _a	T _p	T _a	T _p	T _a	T _p	T _a	
	E, G	T6	-196	59	59	59	85	57	85	-40 -50 ¹⁾	-40 -50 ¹⁾	-40 -50 ¹⁾	-196	-26 -37 ¹⁾
		T5	-196	74	74	74	100	72	100	-40 -50 ¹⁾	-40 -50 ¹⁾	-40 -50 ¹⁾	-196	-26 -37 ¹⁾
		T4	-196	75	75	75	135	71	135	-40 -50 ¹⁾	-40 -50 ¹⁾	-40 -50 ¹⁾	-196	-26 -37 ¹⁾
		T3	-196	75	75	75	200	66	200	-40 -50 ¹⁾	-40 -50 ¹⁾	-40 -50 ¹⁾	-196	-26 -37 ¹⁾
		T2	-196	75	75	75	300	58	300	-40 -50 ¹⁾	-40 -50 ¹⁾	-40 -50 ¹⁾	-196	-26 -37 ¹⁾
		T1	-196	75	75	75	450	47	450	-40 -50 ¹⁾	-40 -50 ¹⁾	-40 -50 ¹⁾	-196	-26 -37 ¹⁾

1) Only in connection with Optional specification, ID Jx (Test, Certificate) = JN

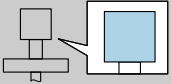
 = C	(2)	P1		P2		P3		P4		P5		P6		
		T _p	T _a	T _p	T _a	T _p	T _a	T _p	T _a	T _p	T _a	T _p	T _a	
	E, G	T6	-196	59	59	59	85	58	85	-40 -50 ¹⁾	-40 -50 ¹⁾	-40 -50 ¹⁾	-196	-27 -38 ¹⁾
		T5	-196	74	74	74	100	73	100	-40 -50 ¹⁾	-40 -50 ¹⁾	-40 -50 ¹⁾	-196	-27 -38 ¹⁾
		T4	-196	75	75	75	135	71	135	-40 -50 ¹⁾	-40 -50 ¹⁾	-40 -50 ¹⁾	-196	-27 -38 ¹⁾
		T3	-196	75	75	75	200	66	200	-40 -50 ¹⁾	-40 -50 ¹⁾	-40 -50 ¹⁾	-196	-27 -38 ¹⁾
		T2	-196	75	75	75	300	59	300	-40 -50 ¹⁾	-40 -50 ¹⁾	-40 -50 ¹⁾	-196	-27 -38 ¹⁾
		T1	-196	75	75	75	450	49	450	-40 -50 ¹⁾	-40 -50 ¹⁾	-40 -50 ¹⁾	-196	-27 -38 ¹⁾

1) Only in connection with Optional specification, ID Jx (Test, Certificate) = JN

FMP55

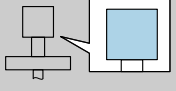
 = A	(2)	P1		P2		P3		P4		P5		P6		
		T _p	T _a	T _p	T _a	T _p	T _a	T _p	T _a	T _p	T _a	T _p	T _a	
	E, G	T6	-50	51	51	51	85	41	85	-40	-40	-40	-50	-35
		T5	-50	56	56	56	100	43	100	-40	-40	-40	-50	-35
		T4	-50	56	56	56	135	32	135	-40	-40	-40	-50	-35

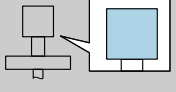
 = B	(2)	P1		P2		P3		P4		P5		P6		
		T _p	T _a	T _p	T _a	T _p	T _a	T _p	T _a	T _p	T _a	T _p	T _a	
	E, G	T6	-50	60	60	60	85	52	85	-40	-40	-40	-50	-37
		T5	-50	75	75	75	100	67	100	-40	-40	-40	-50	-37
		T4	-50	75	75	75	135	62	135	-40	-40	-40	-50	-37
		T3	-50	75	75	75	200	47	200	-40	-40	-40	-50	-37

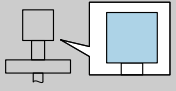
 = C	(2)	P1		P2		P3		P4		P5		P6		
		T _p	T _a	T _p	T _a	T _p	T _a	T _p	T _a	T _p	T _a	T _p	T _a	
	E, G	T6	-50	60	60	60	85	54	85	-40	-40	-40	-50	-37
		T5	-50	75	75	75	100	69	100	-40	-40	-40	-50	-37
		T4	-50	75	75	75	135	63	135	-40	-40	-40	-50	-37
		T3	-50	75	75	75	200	51	200	-40	-40	-40	-50	-37

FMP56

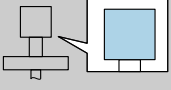
 = A	(2)		P1		P2		P3		P4		P5		P6	
			T _p	T _a	T _p	T _a	T _p	T _a	T _p	T _a	T _p	T _a	T _p	T _a
	E, G	T6	-40	51	51	51	85	40	85	-40	-40	-40	-	-
		T5	-40	56	56	56	100	42	100	-40	-40	-40	-	-
		T4 ¹⁾	-40	56	56	56	120	35	120	-40	-40	-40	-	-

1) Functional: Maximum permissible process temperature

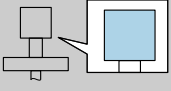
 = B	(2)		P1		P2		P3		P4		P5		P6	
			T _p	T _a	T _p	T _a	T _p	T _a	T _p	T _a	T _p	T _a	T _p	T _a
	E, G	T6	-40	60	60	60	85	51	85	-40	-40	-40	-	-
		T5	-40	75	75	75	100	66	100	-40	-40	-40	-	-
		T4 ¹⁾	-40	75	75	75	120	65	120	-40	-40	-40	-	-

1) Functional: Maximum permissible process temperature

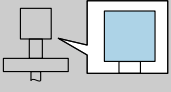
 = C	(2)		P1		P2		P3		P4		P5		P6	
			T _p	T _a	T _p	T _a	T _p	T _a	T _p	T _a	T _p	T _a	T _p	T _a
	E, G	T6	-40	60	60	60	85	54	85	-40	-40	-40	-	-
		T5	-40	75	75	75	100	69	100	-40	-40	-40	-	-
		T4 ¹⁾	-40	75	75	75	120	66	120	-40	-40	-40	-	-

1) Functional: Maximum permissible process temperature

FMP57

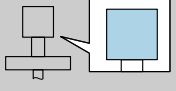
 = A	(2)	P1		P2		P3		P4		P5		P6		
		T _p	T _a	T _p	T _a	T _p	T _a	T _p	T _a	T _p	T _a	T _p	T _a	
	E, G	T6	-40	51	51	51	85	42	85	-40	-40	-40	-	-
		T5	-40	56	56	56	100	45	100	-40	-40	-40	-	-
		T4	-40	56	56	56	135	37	135	-40	-40	-40	-	-

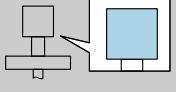
 = B	(2)	P1		P2		P3		P4		P5		P6		
		T _p	T _a	T _p	T _a	T _p	T _a	T _p	T _a	T _p	T _a	T _p	T _a	
	E, G	T6	-40	60	60	60	85	53	85	-40	-40	-40	-	-
		T5	-40	75	75	75	100	68	100	-40	-40	-40	-	-
		T4	-40	75	75	75	135	63	135	-40	-40	-40	-	-
		T3 ¹⁾	-40	75	75	75	185	54	185	-40	-40	-40	-	-

1) Functional: Maximum permissible process temperature

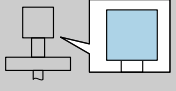
 = C	(2)	P1		P2		P3		P4		P5		P6		
		T _p	T _a	T _p	T _a	T _p	T _a	T _p	T _a	T _p	T _a	T _p	T _a	
	E, G	T6	-40	60	60	60	85	55	85	-40	-40	-40	-	-
		T5	-40	75	75	75	100	70	100	-40	-40	-40	-	-
		T4	-40	75	75	75	135	65	135	-40	-40	-40	-	-
		T3 ¹⁾	-40	75	75	75	185	58	185	-40	-40	-40	-	-

1) Functional: Maximum permissible process temperature

Zone 2: Remote; 1 channel

Probe design: remote

Position 3 (Power Supply, Output) = E, G: 1 channel used

Optional specification, ID Mx (Probe Design) = MB, MC, MD

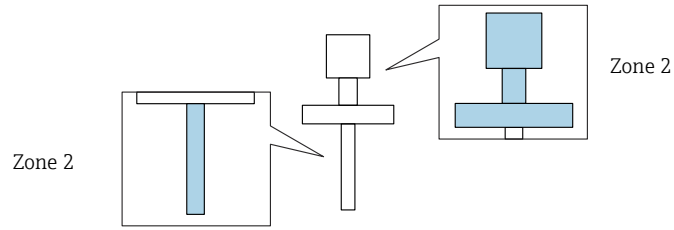

FMP5x

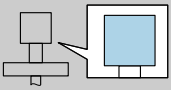
 = A	(1)		P1		P2		P3		P4		P5		P6	
			$T_p^{1)}$	T_a	$T_p^{1)}$	T_a	$T_p^{1)}$	T_a	$T_p^{1)}$	T_a	$T_p^{1)}$	T_a	$T_p^{1)}$	T_a
	E, G	T6	-	58	-	58	-	58	-	-40	-	-40	-	-

1) T_p = dependent on the sensor

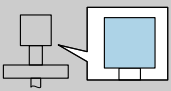
 = B, C	(1)		P1		P2		P3		P4		P5		P6	
			$T_p^{1)}$	T_a	$T_p^{1)}$	T_a	$T_p^{1)}$	T_a	$T_p^{1)}$	T_a	$T_p^{1)}$	T_a	$T_p^{1)}$	T_a
	E, G	T6	-	60	-	60	-	60	-	-40	-	-40	-	-
		T5	-	80	-	80	-	80	-	-40	-	-40	-	-

1) T_p = dependent on the sensor

Zone 2: Remote; 2 channels

Probe design: remote

Position 3 (Power Supply, Output) = E, G: 2 channels used

Optional specification, ID Mx (Probe Design) = MB, MC, MD

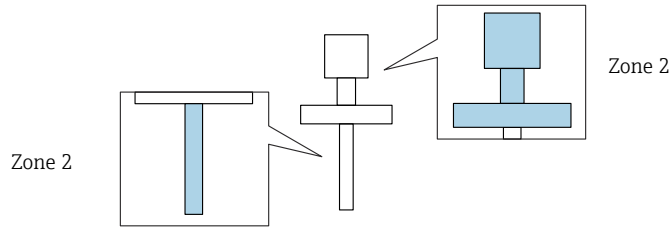

FMP5x

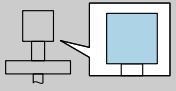
 = A	(2)	P1		P2		P3		P4		P5		P6	
		$T_p^{1)}$	T_a	$T_p^{1)}$	T_a	$T_p^{1)}$	T_a	$T_p^{1)}$	T_a	$T_p^{1)}$	T_a	$T_p^{1)}$	T_a
E, G	T6	-	51	-	51	-	51	-	-40	-	-40	-	-

1) T_p = dependent on the sensor

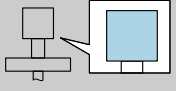
 = B, C	(2)	P1		P2		P3		P4		P5		P6	
		$T_p^{1)}$	T_a	$T_p^{1)}$	T_a	$T_p^{1)}$	T_a	$T_p^{1)}$	T_a	$T_p^{1)}$	T_a	$T_p^{1)}$	T_a
E, G	T6	-	59	-	59	-	59	-	-40	-	-40	-	-
	T5	-	74	-	74	-	74	-	-40	-	-40	-	-

1) T_p = dependent on the sensor



71488764

www.addresses.endress.com
