

Operating Instructions

FlexView FMA90

Control unit with color display and touch control for up to 2 ultrasonic, radar, hydrostatic or universal 4-20 mA/HART® level sensors



Table of contents

1	About this document	4	7.4	Access to the operating menu via operating tools	35
1.1	Symbols	4	8	System integration	36
1.2	Documentation	5	8.1	Measured variables via HART protocol (slave)	36
1.3	Change history	5	8.2	Supported HART commands (slave)	36
2	Basic safety instructions	6	8.3	Open-source license information	38
2.1	Requirements for the personnel	6	9	Commissioning	38
2.2	Intended use	6	9.1	Post-installation check	38
2.3	Workplace safety	6	9.2	Switching on the device	39
2.4	Operational safety	6	9.3	Configuring the operating language at the device	39
2.5	Product safety	7	9.4	User management and permissions	39
2.6	IT security	7	9.5	Configuring the device	41
2.7	Device-specific IT security	7	9.6	Application examples	46
3	Product description	7	9.7	Creating visualization groups	52
3.1	Product layout: polycarbonate field housing ...	8	9.8	Simulation	53
3.2	Product layout: aluminum field housing	8	9.9	Protecting settings from unauthorized access .	55
3.3	Product design: DIN rail device	9	10	Operation	55
3.4	Product design: panel-mounted device	9	10.1	Reading the device locking status	55
4	Incoming acceptance and product identification	9	10.2	Reading measured values on the touch display	56
4.1	Incoming acceptance	9	10.3	Reading measured values via the web server ..	58
4.2	Product identification	10	11	Diagnostics and troubleshooting ...	58
4.3	Storage and transport	10	11.1	General troubleshooting	58
5	Mounting	11	11.2	Active diagnostics	59
5.1	Mounting requirements	11	11.3	Diagnostic list	59
5.2	Mounting the polycarbonate field housing ...	11	11.4	Event logbook	64
5.3	Mounting the aluminum field housing	13	11.5	Minimum/maximum values	64
5.4	Installing a DIN rail device	14	11.6	Simulation	65
5.5	Mounting in a panel	15	11.7	Diagnostic settings	65
5.6	Disassembling the device	16	11.8	HART master	66
5.7	Post-mounting check	16	11.9	Device reset	66
6	Electrical connection	17	11.10	Device information	66
6.1	Connecting requirements	17	11.11	Enabling software options	66
6.2	Connecting the device	17	11.12	Firmware update	66
6.3	Special connection instructions	27	12	Maintenance	67
6.4	Hardware settings	29	12.1	Cleaning	67
6.5	Ensuring the degree of protection	29	13	Repair	67
6.6	Post-connection check	30	13.1	General information	67
7	Operation options	31	13.2	Replacing a device or electronics module	67
7.1	Structure and function of the operating menu	31	13.3	Replacing a sensor	68
7.2	Access to the operating menu via the local display	33	13.4	Replacing the battery	68
7.3	Access to the operating menu via web browser	34	13.5	Spare parts	68
			13.6	Return	68
			13.7	Disposal	68

14	Accessories	68
14.1	Device-specific accessories	69
14.2	Service-specific accessories	70
14.3	Online tools	70
14.4	System components	70
15	Technical data	70
15.1	Input	70
15.2	Output	71
15.3	Power supply	74
15.4	Performance characteristics	81
15.5	Mounting	81
15.6	Environment	82
15.7	Mechanical construction	84
15.8	Operability	87
15.9	Certificates and approvals	89
15.10	Ordering information	89
15.11	Supplementary documentation	90

1 About this document

1.1 Symbols

1.1.1 Safety symbols

DANGER

This symbol alerts you to a dangerous situation. Failure to avoid this situation will result in serious or fatal injury.

WARNING

This symbol alerts you to a potentially dangerous situation. Failure to avoid this situation can result in serious or fatal injury.













CAUTION

This symbol alerts you to a potentially dangerous situation. Failure to avoid this situation can result in minor or medium injury.





NOTICE

This symbol alerts you to a potentially harmful situation. Failure to avoid this situation can result in damage to the product or something in its vicinity.

1.1.2 Symbols for certain types of information

Symbol	Meaning
	Permitted Procedures, processes or actions that are permitted.
	Preferred Procedures, processes or actions that are preferred.
	Forbidden Procedures, processes or actions that are forbidden.
	Tip Indicates additional information.
	Reference to documentation
	Reference to page
	Reference to graphic
	Notice or individual step to be observed
	Series of steps
	Result of a step
	Help in the event of a problem
	Visual inspection



1.1.3 Electrical symbols

	Direct current		Alternating current		Direct and alternating current
	Ground connection		Protective earth (PE)		

1.1.4 Symbols in graphics

1, 2, 3,...	Item numbers	A, B, C, ...	Views
-------------	--------------	--------------	-------

1.1.5 Symbols on the device

	Warning Observe the safety instructions contained in the associated Operating Instructions
	Device protected all over by DOUBLE INSULATION or REINFORCED INSULATION

1.2 Documentation

 For an overview of the scope of the associated Technical Documentation, refer to the following:

- *Device Viewer* (www.endress.com/deviceviewer): Enter the serial number from the nameplate
- *Endress+Hauser Operations app*: Enter serial number from nameplate or scan matrix code on nameplate.

The following document types are available in the Downloads area of the Endress+Hauser website (www.endress.com/downloads), depending on the product configuration:

Document type	Purpose and content of the document
Technical Information (TI)	Planning aid This document contains all the technical data on the product and provides an overview of everything that can be ordered with the product.
Brief Operating Instructions (KA)	Quick guide to obtaining the first measured value The Operating Instructions contain all the essential information about the product from incoming acceptance to initial commissioning.
Operating Instructions (BA)	Reference The Operating Instructions contain the information that is required in the various phases of the life cycle of the product: From product identification, incoming acceptance and storage, to mounting, connection, operation and commissioning through to troubleshooting, maintenance and disposal.
Description of Device Parameters (GP)	Reference for parameters The document contains detailed explanations of readable or configurable parameters in the product. The description is aimed at those who work with the product over its entire life cycle and perform specific configurations.
Safety Instructions (XA)	Safety Instructions for electrical equipment in hazardous areas are supplied with the product depending on the approval. These are an integral part of the Operating Instructions.  The nameplate indicates the Safety Instructions (XA) that are relevant to the product.
Supplementary device-dependent documentation (SD/FY)	Always comply strictly with the instructions in the relevant supplementary documentation. The supplementary documentation is an integral part of the product documentation.

1.3 Change history

Device software Version/date	Software changes	Operating Instructions
V01.01.zz/06.2026	Original software with HART output	BA02604F/01.26

2 Basic safety instructions

2.1 Requirements for the personnel

The personnel for installation, commissioning, diagnostics and maintenance must fulfill the following requirements:

- ▶ Trained, qualified specialists must have a relevant qualification for this specific function and task.
- ▶ Are authorized by the plant owner/operator.
- ▶ Are familiar with federal/national regulations.
- ▶ Before starting work, read and understand the instructions in the manual and supplementary documentation as well as the certificates (depending on the application).
- ▶ Follow instructions and comply with basic conditions.

The operating personnel must fulfill the following requirements:

- ▶ Are instructed and authorized according to the requirements of the task by the facility's owner-operator.
- ▶ Follow the instructions in this manual.

2.2 Intended use

The device is designed for the water and wastewater industry for the evaluation of measured values and device status, as well as for the configuration of the following Endress+Hauser sensors:

- Radar time-of-flight method: Micropilot FMR10B ¹⁾, FMR20B, FMR30B
- Ultrasonic time-of-flight method: Prosonic FMU20B; FMU30B
- Hydrostatic level measurement: Waterpilot FMX11 ¹⁾, FMX21

Universal level sensors can also be connected to the 4 to 20 mA/HART inputs.

Typical measuring tasks

- Level measurement and linearization
- Flow measurement at open flumes and weirs
- Pump control
- Rake control

2.2.1 Product liability

The manufacturer does not accept any responsibility for damage that results from non-designated use and from failure to comply with the instructions in this manual.

2.3 Workplace safety

For work on and with the device:

- ▶ Wear the required personal protective equipment according to federal/national regulations.

2.4 Operational safety

Risk of injury!

- ▶ Operate the device only if it is in proper technical condition, free from errors and faults.
- ▶ The operator is responsible for interference-free operation of the device.

1) 4 to 20 mA only, configuration via HART not possible

Modifications to the device

Unauthorized modifications to the device are not permitted and can lead to unforeseeable dangers:

- ▶ If modifications are nevertheless required, consult with the manufacturer.

Repair

To ensure continued operational safety and reliability:

- ▶ Carry out repairs on the device only if they are expressly permitted.
- ▶ Observe federal/national regulations pertaining to the repair of an electrical device.
- ▶ Use only original spare parts and accessories from the manufacturer.

Hazardous area

To eliminate danger to persons or the facility when the device is used in the hazardous area (e.g. explosion protection):

- ▶ Check the nameplate to verify if the device ordered can be put to its intended use in the hazardous area.
- ▶ Observe the specifications in the separate supplementary documentation that is an integral part of these instructions.

2.5 Product safety

This product is designed in accordance with good engineering practice to meet state-of-the-art safety requirements and has been tested and left the factory in a condition in which it is safe to operate.

2.6 IT security

The manufacturer warranty is valid only if the product is installed and used as described in the Operating Instructions. The product is equipped with security mechanisms to protect it against any inadvertent changes to the settings.

IT security measures, which provide additional protection for the product and associated data transfer, must be implemented by the operators themselves in line with their security standards.

2.7 Device-specific IT security

The device was developed in accordance with the requirements of the IEC 62443-4-1 "Secure product development lifecycle management" standard.

Link to the cybersecurity website: <https://www.endress.com/cybersecurity>



Further information on cybersecurity: see product-specific security manual (SD).

3 Product description



The following diagrams each show a possible version of the device. Depending on the device version, there may be more or fewer terminals.

3.1 Product layout: polycarbonate field housing

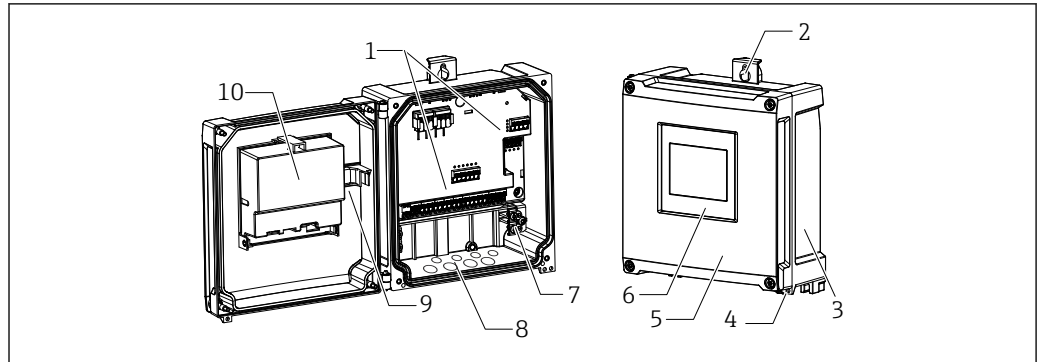

A0051691

1 Structure of polycarbonate field housing

- 1 Terminals
- 2 Housing bracket
- 3 Nameplate
- 4 Sealing option
- 5 Cover of terminal compartment
- 6 Display and operating module
- 7 Grounding terminal block
- 8 Precut openings for cable entries
- 9 Display-to-mainboard connecting cable
- 10 Function diagram on CPU cover

3.2 Product layout: aluminum field housing

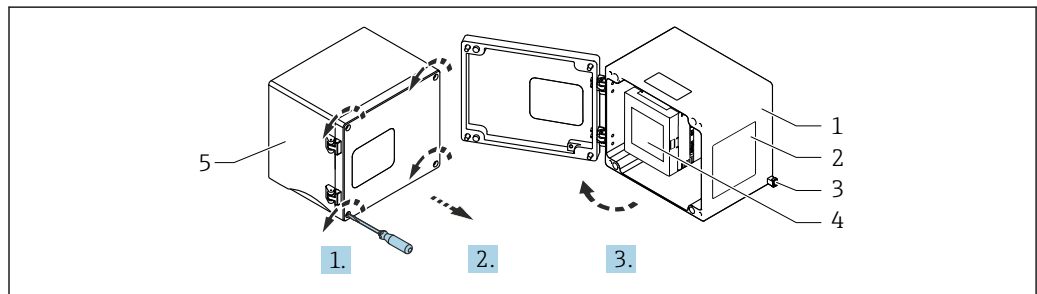

A0053240

2 Access to terminal compartment in aluminum field housing

- 1 Aluminum field housing, open
- 2 Nameplate
- 3 Terminal for protective ground
- 4 Display and operating module NOHrD FMA90 (DIN rail device)
- 5 Aluminum field housing, closed

3.3 Product design: DIN rail device

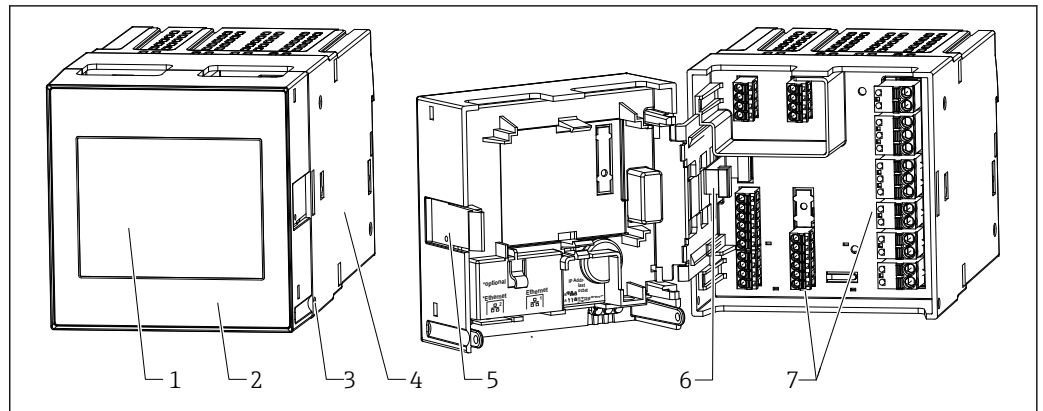

A0051693

3 Structure of the DIN rail device

- 1 Display and operating module (optional)
- 2 Cover of terminal compartment
- 3 Sealing option
- 4 Nameplate
- 5 Unlocking mechanism
- 6 Display-to-mainboard connecting cable
- 7 Terminals

3.4 Product design: panel-mounted device

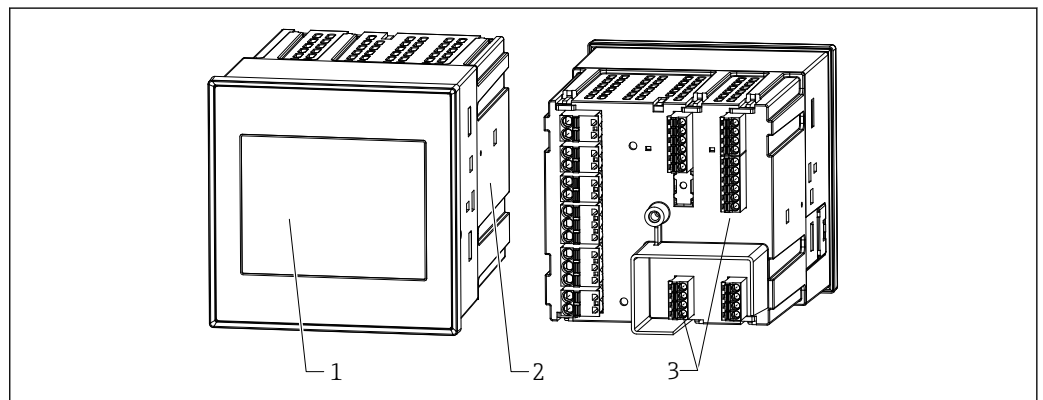

A0051694

4 Structure of the panel-mounted device

- 1 Display and operating module
- 2 Nameplate
- 3 Terminals

4 Incoming acceptance and product identification

4.1 Incoming acceptance

On receipt of the delivery:

1. Check the packaging for damage.
 - ↳ Report all damage immediately to the manufacturer. Do not install damaged components.

2. Check the scope of delivery using the delivery note.
3. Compare the data on the nameplate with the order specifications on the delivery note.
4. Check the technical documentation and all other necessary documents, e.g. certificates, to ensure they are complete.

 If one of the conditions is not satisfied, contact the manufacturer.

4.2 Product identification

The device can be identified in the following ways:

- Nameplate specifications
- Extended order code with breakdown of the device features on the delivery note
- Enter the serial number from the nameplate into *Device Viewer* (www.endress.com/deviceviewer): All the information about the device and an overview of the technical documentation supplied with the device are displayed.

4.2.1 Nameplate

Do you have the correct device?

The nameplate provides you with the following information on the device:

- Manufacturer identification, device designation
- Order code
- Extended order code
- Serial number
- Tag name (TAG) (optional)
- Technical values such as supply voltage, current consumption, ambient temperature, communication-specific data (optional)
- Degree of protection
- Approvals with symbols
- Reference to Safety Instructions (XA) (optional)

► Compare the information on the nameplate with the order.

4.2.2 Name and address of manufacturer

Name of manufacturer:	Endress+Hauser Wetzer GmbH + Co. KG
Address of manufacturer:	Obere Wank 1, D-87484 Nesselwang
Model/type reference:	FMA90

4.3 Storage and transport

Storage temperature: -40 to +80 °C (-40 to +176 °F)

Maximum relative humidity: < 95%

 Pack the device for storage and transportation in such a way that it is reliably protected against impact and external influences. The original packaging provides the best protection.

Avoid the following environmental influences during storage:

- Direct sunlight
- Proximity to hot objects
- Mechanical vibration
- Aggressive media

5 Mounting

5.1 Mounting requirements

NOTICE

- ▶ When using in hazardous areas, the limit values of the certificates and approvals must be observed.

i For information on ambient conditions, see the "Technical data" section.

5.2 Mounting the polycarbonate field housing

5.2.1 Mounting requirements

Dimensions of the polycarbonate field housing

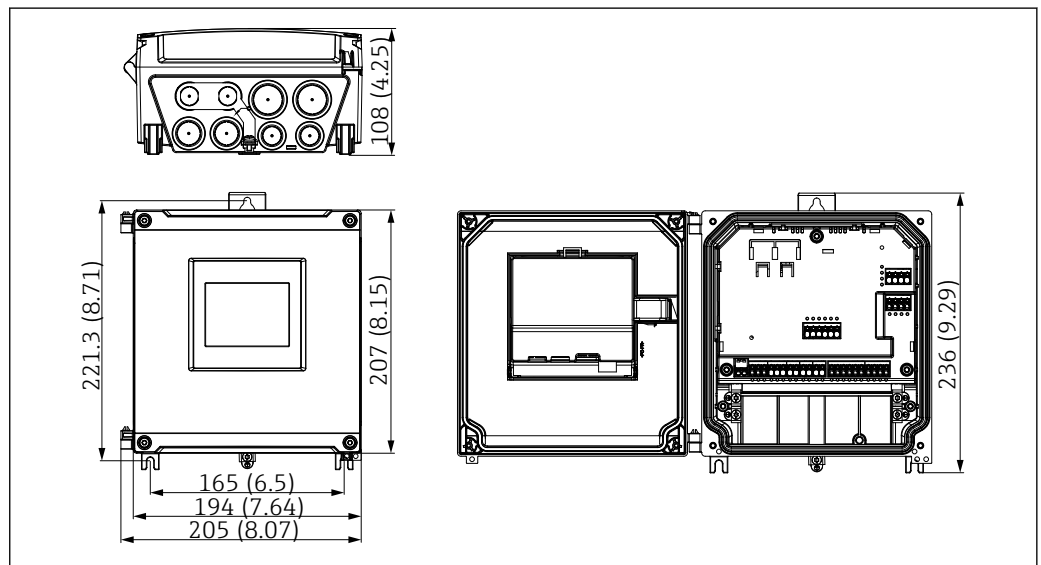

5 Dimensions of the polycarbonate field housing. Unit of measurement mm (in)

Mounting location

- Protected from direct sunlight. Use a weather protection cover if necessary.
- If mounting outdoors: use a surge arrester.
- Minimum clearance to the left: 55 mm (2.17 in); the housing cover cannot be opened otherwise.
- Orientation: vertical

5.2.2 Mounting the device

Wall mounting

The polycarbonate field housing is mounted directly on the wall using 3 screws (ϕ 5 mm (0.20 in), L: min. 50 mm (1.97 in); suitable wall plugs are recommended; not included in the scope of delivery).

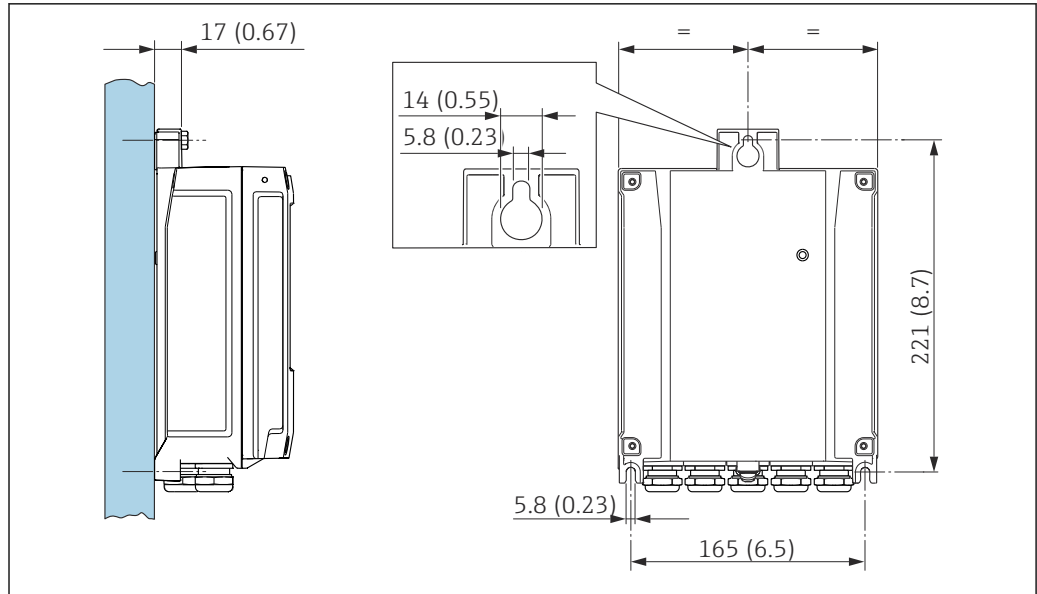

6 Wall-mounted polycarbonate field housing. Unit of measurement mm (in)

Pipe mounting (accessories) for polycarbonate field housing

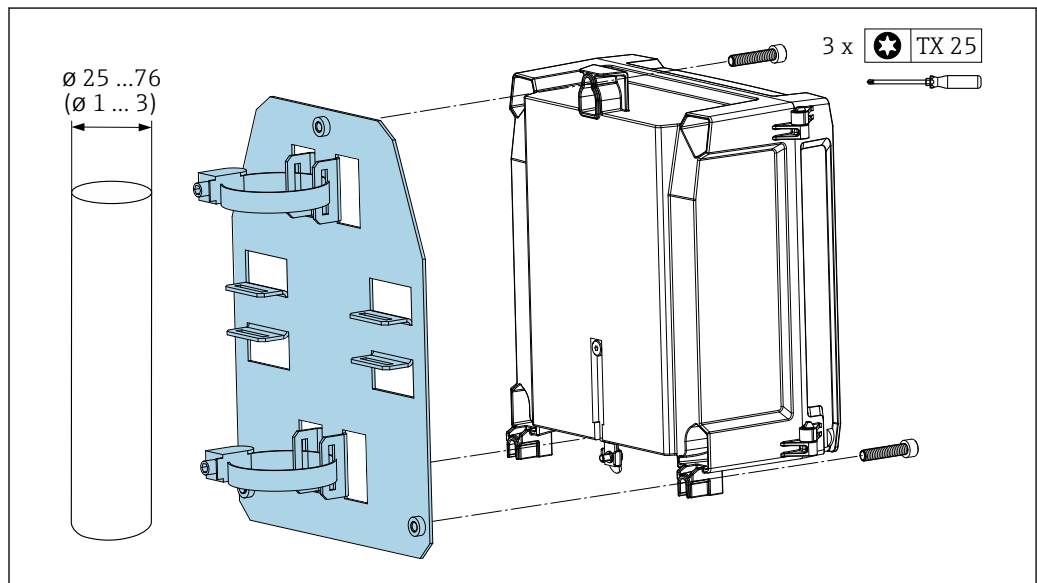

7 Mounting plate for pipe mounting of polycarbonate field housing. Unit of measurement mm (in)

Mounting protective cover (accessories) for polycarbonate field housing

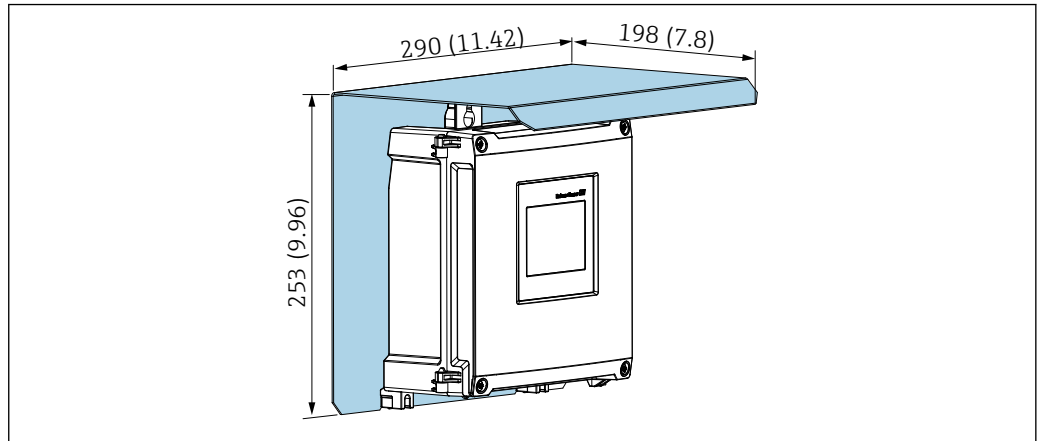

A0053172

8 Protective cover (accessories) for direct wall mounting or using mounting plate (accessories) for pipe mounting. Unit of measurement mm (in)

5.3 Mounting the aluminum field housing

The DIN rail device can be installed in the aluminum field housing.

5.3.1 Mounting requirements

Dimensions of the aluminum field housing

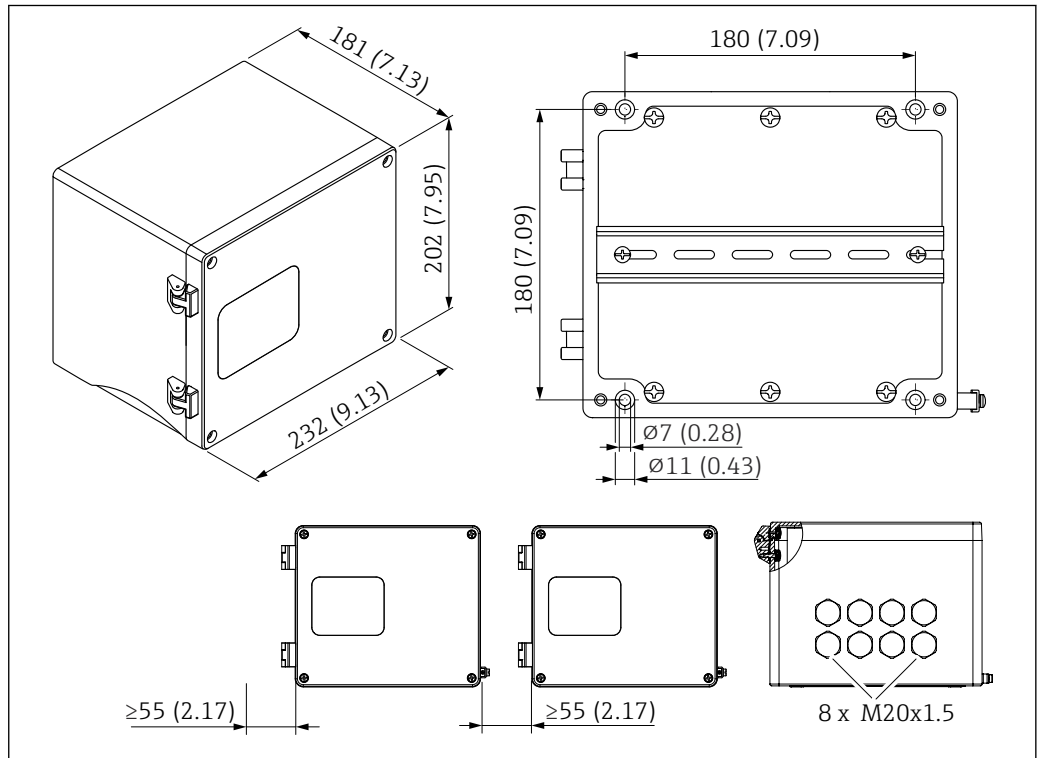

A0053123

9 Dimensions of the aluminum field housing. Unit of measurement mm (in)

Mounting location

- Protected from direct sunlight
- If mounting outdoors: use a surge arrester
- Minimum clearance to the left: 55 mm (2.17 in), the housing cover cannot be opened otherwise

5.3.2 Mounting the device

The aluminum field housing is mounted directly on the wall using 4 screws (ϕ 7 mm (0.28 in), L: min. 50 mm (1.97 in)); not included in the scope of delivery).

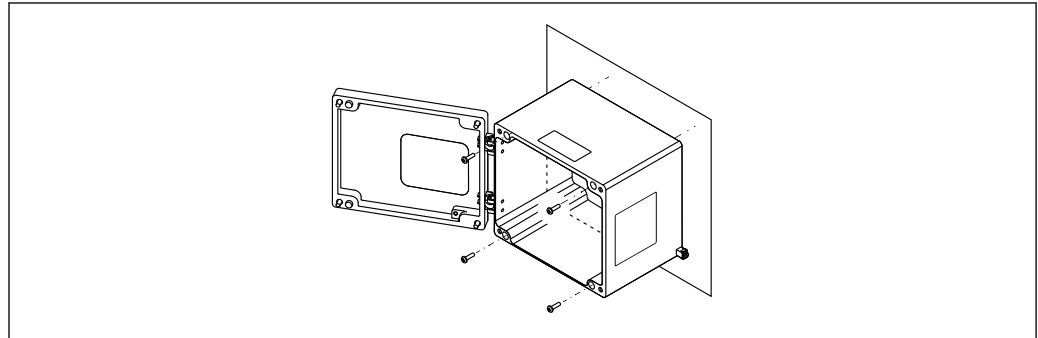

A0053242

10 Wall-mounted aluminum field housing

5.4 Installing a DIN rail device

i The DIN rail device is available with or without a display unit (optional). The installation is the same.

5.4.1 Mounting requirements

Dimensions

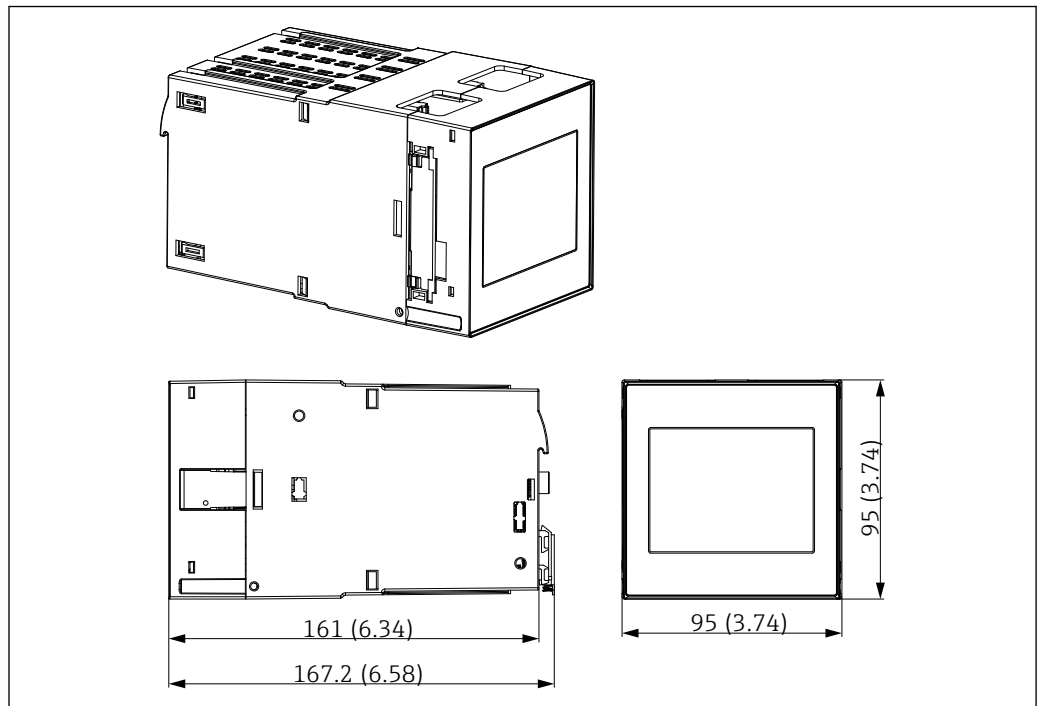

A0051669

11 Dimensions of the DIN rail device. Unit of measurement mm (in)

Mounting location

- In the cabinet outside hazardous areas
- At a sufficient distance from high-voltage electric cables, motor cables, contactors or frequency converters
- Minimum distance to the left: 20 mm (0.8 in)
To protect against overheating, keep the vents at the top and bottom free
- Orientation: vertical

5.4.2 Mounting the device

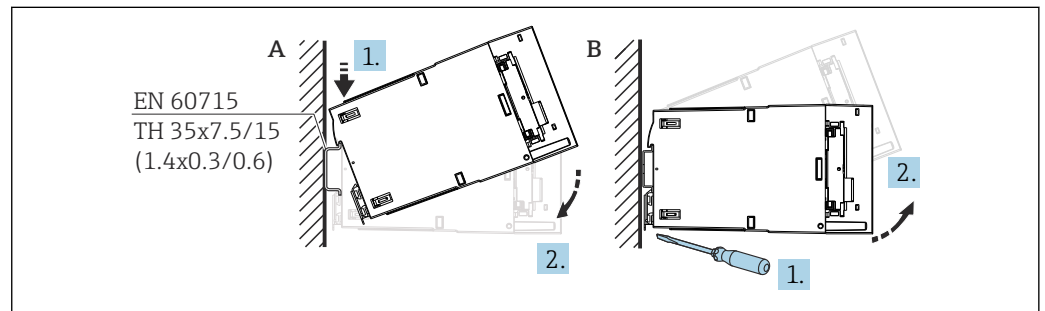

12 Mounting/disassembling the DIN rail housing. Unit of measurement mm (in)

A Mounting

B Disassembly (use a suitable tool to release the locking device at the bottom)

5.5 Mounting in a panel

5.5.1 Mounting requirements

Ensure compliance with the permitted ambient conditions during installation and operation. The device must be protected from exposure to heat.

Installation dimensions

Required panel cutout 92 mm (3.62 in) x 92 mm (3.62 in). Installation depth of 160 mm (6.3 in) for device and cable.

Mounting location

For installation in a panel. The mounting location must be free from vibrations. A suitable electrical, fire-proof and mechanical enclosure must be provided.

Orientation

- Vertical
- Lateral clearance (arranged side-by-side) min. 10 mm (0.4 in)

i When connecting Ethernet cables, observe the clearance below.

5.5.2 Mounting the device

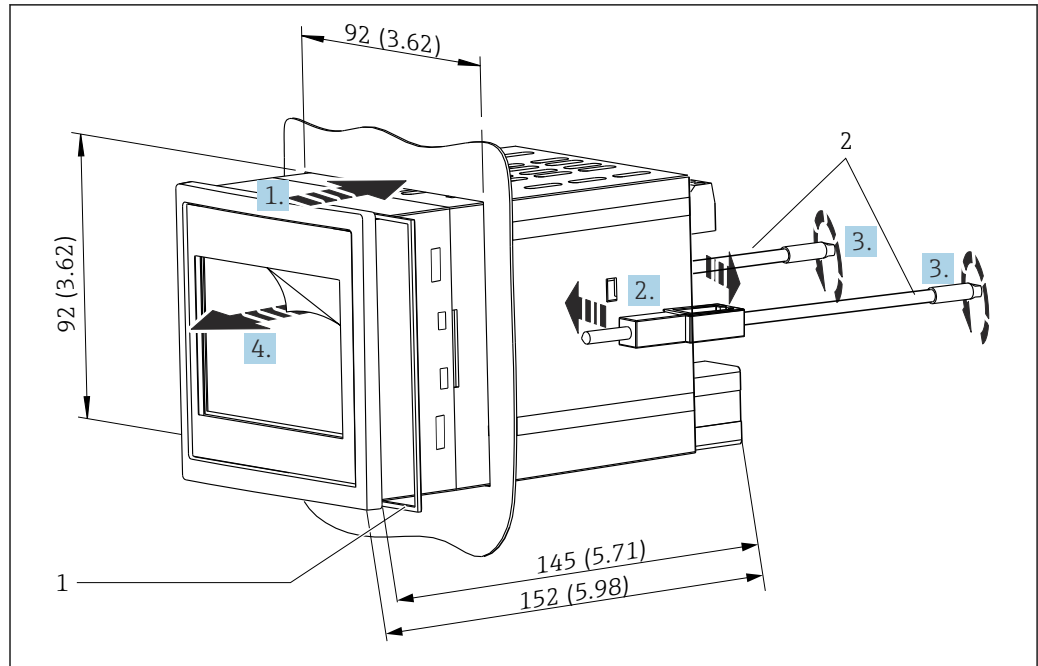

13 Installation in a panel. Unit of measurement mm (in)

Mounting the device in a panel

1. Push the device with the sealing ring (item 1) through the panel cutout from the front.
2. Hold the device horizontally and clip the fastening clips (item 2) into the openings provided on both sides.
3. Tighten the screws of the fastening clips uniformly using a screwdriver (fastening torque: 0.2 Nm).
4. Remove the protective film of the touch screen.

5.6 Disassembling the device

The device is disassembled by following the installation procedure in the reverse order.

5.7 Post-mounting check

Device condition and specifications	Notes
Is the device undamaged (visual inspection)?	-
Do the ambient conditions match the device specification (e.g. ambient temperature, measuring range etc.)?	See 'Technical data'
If provided: are the measuring point number and labeling correct?	-
Is the device mounted correctly? (Visual inspection)	-
Is the device adequately protected against precipitation and direct sunlight?	See Accessories

6 Electrical connection

6.1 Connecting requirements

CAUTION

Destruction of parts of the electronics

- ▶ Switch off power supply before installing or connecting the device.

 For information on the connection data, see the "Technical data" section.

 For the 85 to 253 V_{AC} version (mains connection), a switch marked as a circuit breaker, as well as an overload protection device (rated power ≤ 10 A) must be fitted in the supply line near the device (easy to reach).

 For the 10.5 to 32 V_{DC} version: The device must only be powered by a power unit that operates using an energy-limited electric circuit according to UL/EN/IEC 61010-1, Section 9.4 and the requirements in Table 18.

Apart from the relay and the AC supply voltage, only energy-limited circuits according to IEC/EN 61010-1 shall be connected.

6.1.1 Cable specification

CAUTION

Unsuitable connection cables may cause overheating and fire hazards, insulation damage, electric shock, power loss, and reduced operating life.

- ▶ Only use connection cables that comply with the specifications below.

 Minimum requirement: Cable temperature range ≥ ambient temperature +20 K

For all connections on the field device and for power and relay connections in the case of the panel-mounted and DIN rail device:

- **Conductor cross-section:** 0.2 to 2.5 mm² (26 to 14 AWG)
- **Cross-section with wire end ferrule:** 0.25 to 2.5 mm² (24 to 14 AWG)
- **Stripping length:** 10 mm (0.39 in)

For digital input, open collector and analog input/output connections in the case of panel-mounted and DIN rail device:

- **Conductor cross-section:** 0.2 to 1.5 mm² (26 to 16 AWG)
- **Cross-section with wire end ferrule (excluding collar/including collar):**
0.25 to 1 mm² (24 to 16 AWG)/ 0.25 to 0.75 mm² (24 to 16 AWG)
- **Stripping length:** 10 mm (0.39 in)

6.1.2 Terminals

The device is fitted with push-in terminals. Rigid conductors or flexible conductors with ferrules can be inserted directly into the terminal without using the lever, and create a contact automatically.

6.2 Connecting the device

6.2.1 DIN rail device

Device version: Order code 040 (housing); option A (DIN rail mounting)

Access to terminals

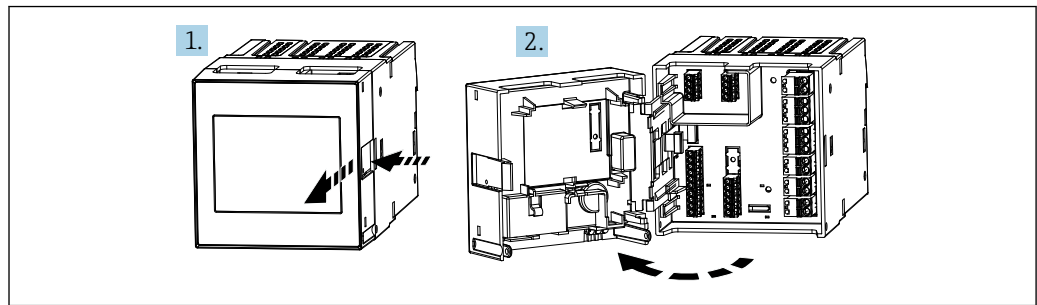

A0051654

6.2.2 Panel-mounted device

Device version: Order code 040 (housing); option B (panel mounting)

Access to terminals

The terminals are freely accessible at the rear of the device.

6.2.3 Terminal compartment of polycarbonate field housing

Device version: Order code 040 (housing); option C (polycarbonate field housing)

Access to terminal compartment

Required tool: Torx T8 or flat-blade screwdriver

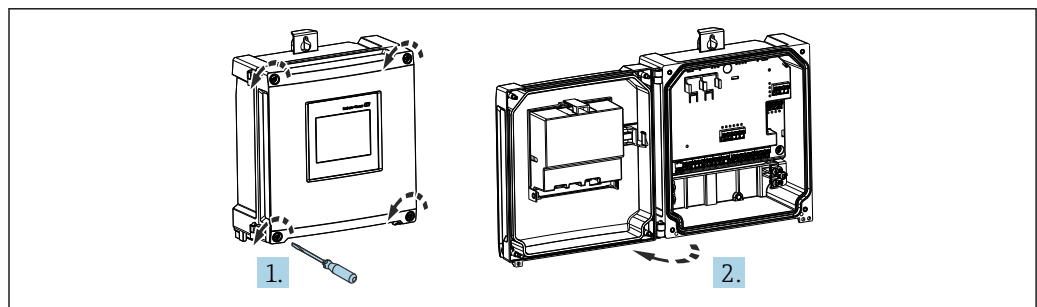

A0053259

14 Access to terminal compartment in polycarbonate field housing

Cable entries of polycarbonate field housing

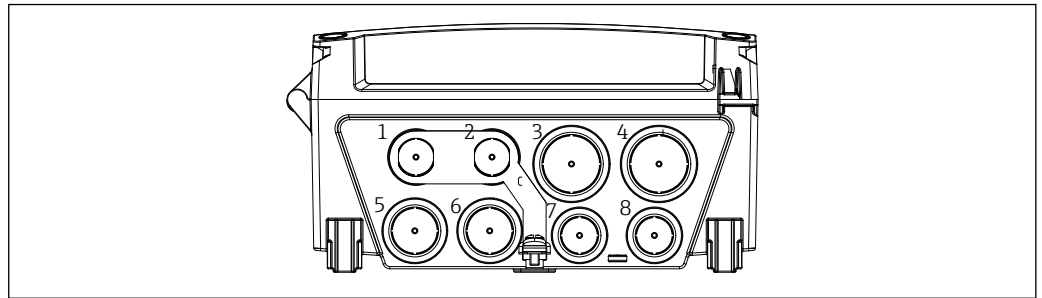

A0061447

15 Precut openings on the bottom of the housing for the following cable entries (example):

- 1 M16x1.5 for Ethernet 2 when using M12 connection or digital I/O
- 2 M16x1.5 for Ethernet 1 when using M12 connection or digital I/O
- 3 M25x1.5 for Ethernet 2 when using a patch cable, digital I/O, or analog I/O
- 4 M25x1.5 for Ethernet 1 when using a patch cable, digital I/O, or analog I/O
- 5 M20x1.5 for power supply
- 6 M20x1.5 for digital I/O
- 7 M16x1.5 for analog I/O
- 8 M16x1.5 for analog I/O

Use a suitable tool to cut out the required openings.

6.2.4 Terminal compartment of aluminum field housing

Device version: Order code 040 (housing); option D (aluminum field housing)

Access to terminal compartment

Required tool: Torx T8 or flat-blade screwdriver

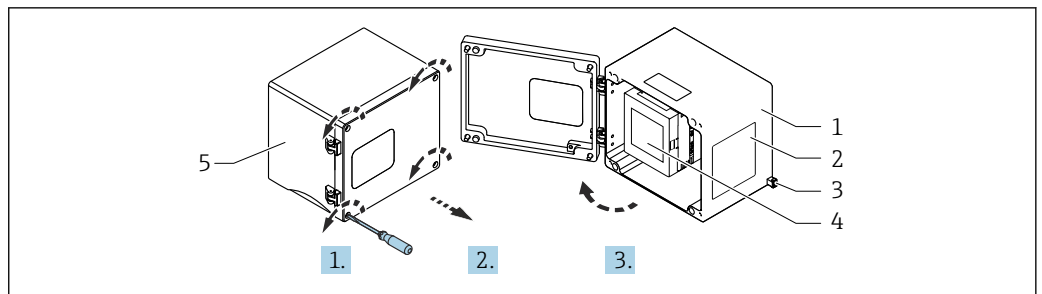

A0053240

16 Access to terminal compartment in aluminum field housing

- 1 Aluminum field housing, open
- 2 Nameplate
- 3 Terminal for protective ground
- 4 FMA90 DIN rail device
- 5 Aluminum field housing, closed



Cable entries for aluminum field housing

- There are eight M20x1.5 openings with dummy covers for cable entries on the bottom of the field housing.
- For the electrical connection, remove the dummy covers and replace them with cable glands. Guide the cables through the cable glands and into the housing. The device is then connected in the same way as the DIN rail device.
- Ethernet cable connection: Insert the cable without the plug and then mount the plug inside.

6.2.5 Terminal areas of DIN rail device

Device version

Order code 040 (housing); option A (DIN rail mounting)

-  The DIN rail device is designed for installation in the optional aluminum field housing.
-  The DIN rail device is available with or without a display unit (optional). The electrical connection is the same.

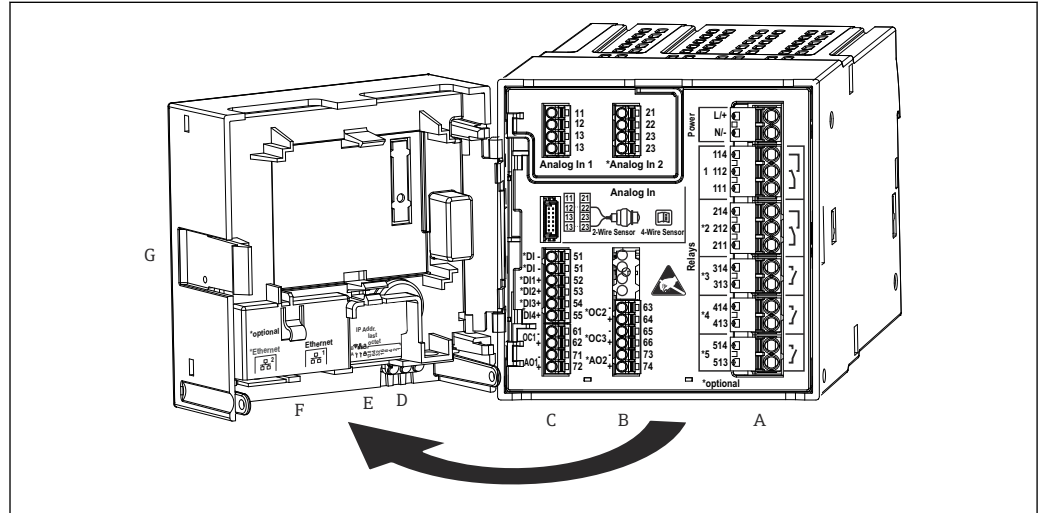

A0049209

 17 Terminals for DIN rail device; terminal design: attachable push-in terminals

- A Power unit with relay 1 (changeover contact). Optional: Relay 2 to 5
- B I/O option card with analog input 2 (incl. loop power supply), analog output 2, open collector 2, 3
- C Standard I/O card with analog input 1 (incl. loop power supply), analog output 1, open collector 1, optional: digital inputs 1 to 4
- D 3 LEDs (only for version without display): DS (device status), NS (network status), WLAN
- E DIP switch
- F Ethernet connection 1 (standard), Ethernet connection 2 (optional)
- G Unlocking device

-  The switching positions of the relays shown on the terminal area refer to the de-energized (current-free) state.

6.2.6 Terminal areas of panel-mounted device

Device version

Order code 040 (housing); option B (panel mounting)

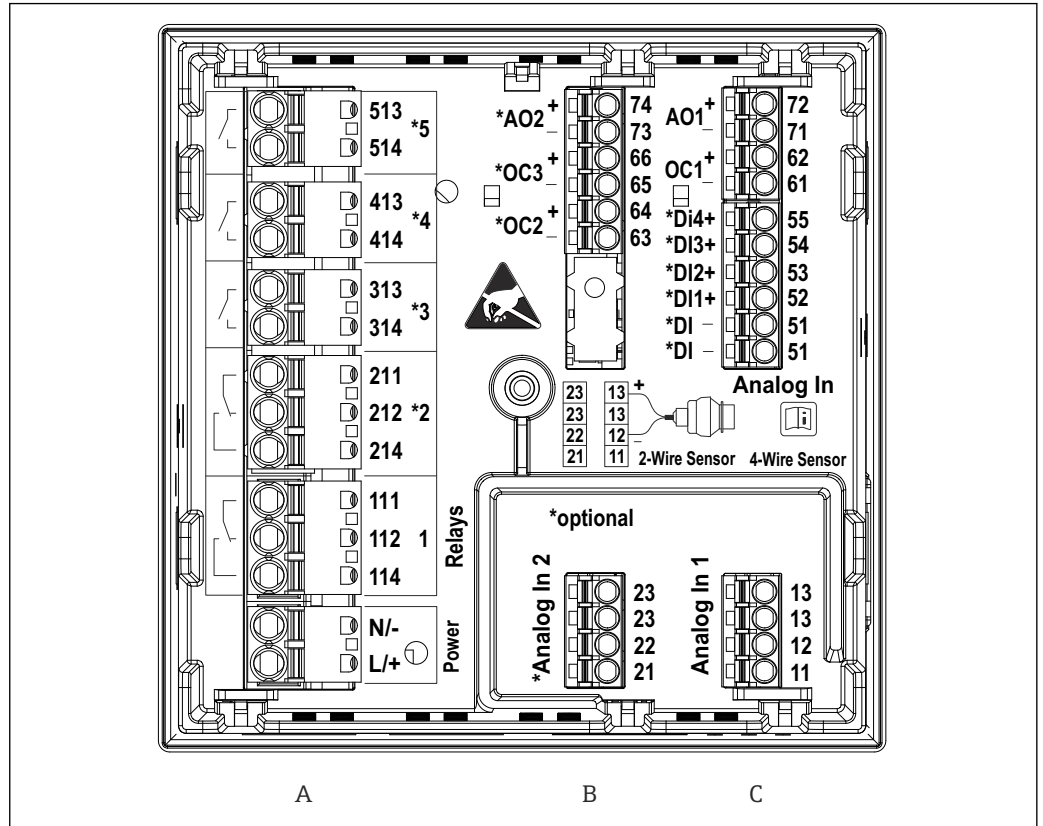

A0049208

18 Terminals for panel-mounted device (rear of device); terminal design: attachable push-in terminals

- A Power unit with relay 1 (changeover contact). Optional: Relay 2 to 5
- B I/O option card with analog input 2 (incl. loop power supply), analog output 2, open collector 2, 3
- C Standard I/O card with analog input 1 (incl. loop power supply), analog output 1, open collector 1, optional: digital inputs 1 to 4

i The switching positions of the relays shown on the terminal area refer to the de-energized (current-free) state.

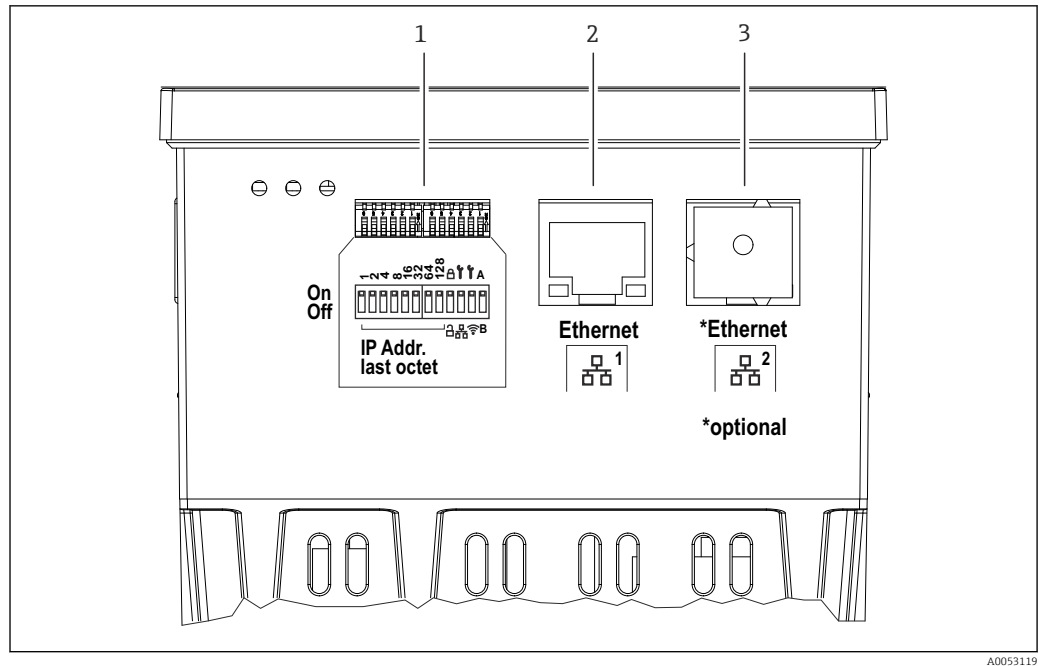

A0053119

19 Connections for panel-mounted device (underside of devices)

- 1 DIP switch
- 2 Ethernet connection 1 (standard)
- 3 Ethernet connection 2 (optional)

6.2.7 Terminal areas of polycarbonate field housing

Device version

Order code 040 (housing); option C (field mounting, polycarbonate)

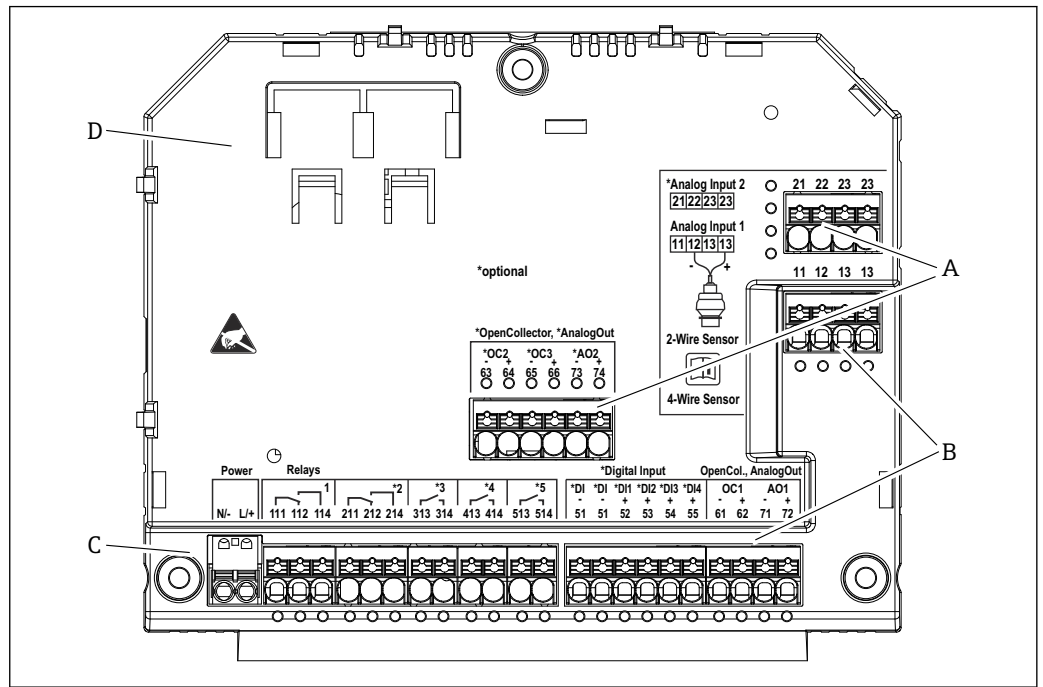

A0050062

20 Terminals in terminal compartment of polycarbonate field housing; terminal design: push-in terminals

- A Terminal area for analog input 2 (incl. loop power supply), analog output 2, open collector 2, 3
- B Terminal area for analog input 1 (incl. loop power supply), analog output 1, open collector 1, optional: Digital inputs 1 to 4
- C Terminal area for power supply and relay 1 (changeover contact). Optional: Relay 2 to 5
- D Holder for commercially available shunting clamps

i The switching positions of the relays shown on the terminal area refer to the de-energized (current-free) state.

Terminal areas on rear side of display for the polycarbonate field housing

Device version

Order code 040 (housing); option C (field mounting, polycarbonate)

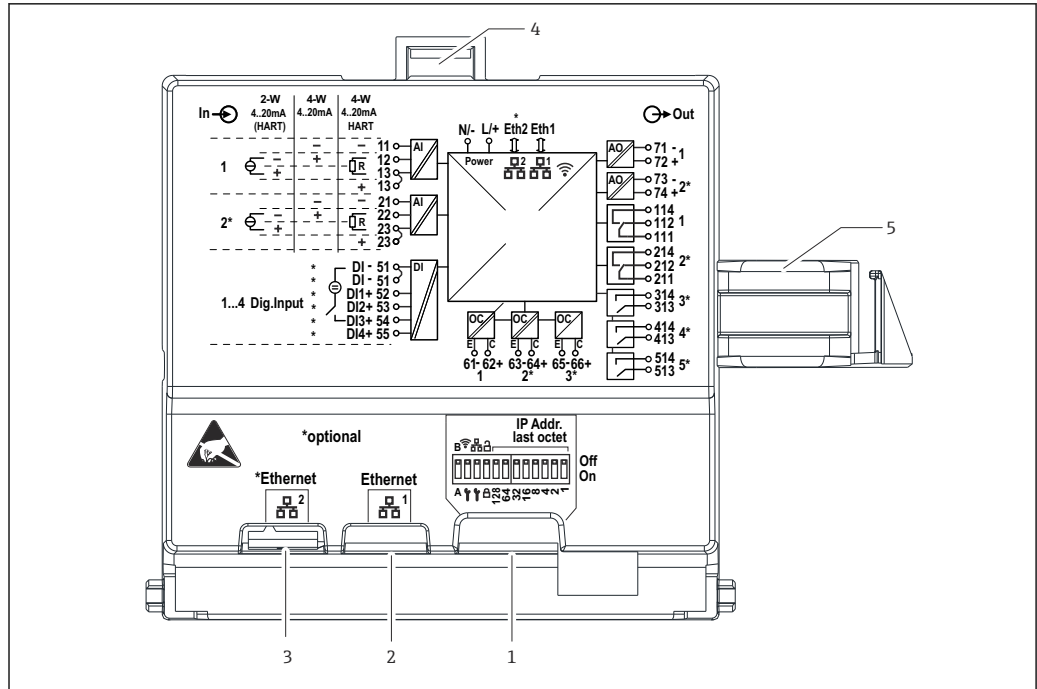

A0052157

21 Connections on the rear side of display for the polycarbonate field housing

- 1 DIP switch
- 2 Ethernet connection 1 (standard)
- 3 Ethernet connection 2 (optional)
- 4 Locking device
- 5 Connecting cable to the main board

i Adapters for RJ45 to M12 connectors are available as an option for the field housing (see "Accessories" section in Operating Instructions). The adapters connect the RJ45 Ethernet interfaces with the M12 connectors mounted in the cable entries. Therefore the connection to the Ethernet interface can be established via an M12 connector without opening the device.

6.2.8 Block diagram and terminal table

Block diagram

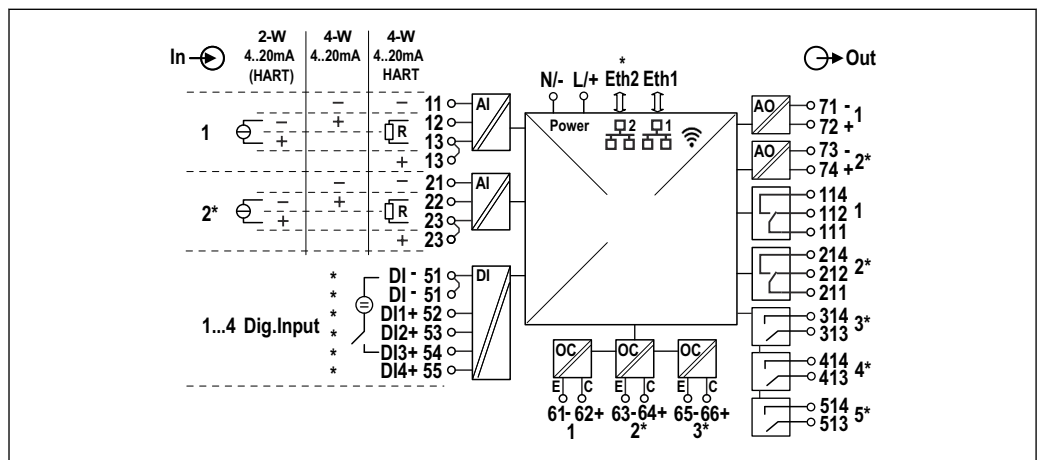

A0054893

22 Connection diagram (terminals marked with * depend on options)

Terminal table

Terminal	Terminal assignment	Description
L/+	L for AC + for DC	Power supply
N/-	N for AC - for DC	
11	Only for 4-wire: - Current measuring input	Analog input 1
12	For 2-wire: - of sensor For 4-wire: + Current measuring input For 4-wire with HART: Communication resistor	
13	For 2-wire: + of sensor For 4-wire with HART: Communication resistor	
13	Only for 4-wire with HART: + of sensor output (LPS must be disabled)	
21	Only for 4-wire: - Current measuring input	Analog input 2 (optional)
22	For 2-wire: - of sensor For 4-wire: + Current measuring input For 4-wire with HART: Communication resistor	
23	For 2-wire: + of sensor For 4-wire with HART: Communication resistor	
23	Only for 4-wire with HART: + of sensor output (LPS must be disabled)	
51 (2x)	- For digital inputs 1 to 4	Digital inputs/switch inputs (optional)
52	+ Digital input 1 (external switch 1)	
53	+ Digital input 2 (external switch 2)	
54	+ Digital input 3 (external switch 3)	
55	+ Digital input 4 (external switch 4)	
61	-	Open Collector 1
62	+	
63	-	Open collector 2 (optional)
64	+	
65	-	Open collector 3 (optional)
66	+	
71	- (0/4 to 20 mA, HART (optional))	Analog output 1
72	+ 0/4 to 20 mA	
73	- (0/4 to 20 mA)	Analog output 2 (optional)
74	+ 0/4 to 20 mA	
111	Common (COM)	Relay 1
112	Normally closed (NC)	
114	Normally open (NO)	
211	Common (COM)	Relay 2 (optional)
212	Normally closed (NC)	
214	Normally open (NO)	
313	Common (COM)	Relay 3 (optional)
314	Normally open (NO)	
413	Common (COM)	Relay 4 (optional)
414	Normally open (NO)	

Terminal	Terminal assignment	Description
513	Common (COM)	Relay 5 (optional)
514	Normally open (NO)	

6.2.9 Sensor connection

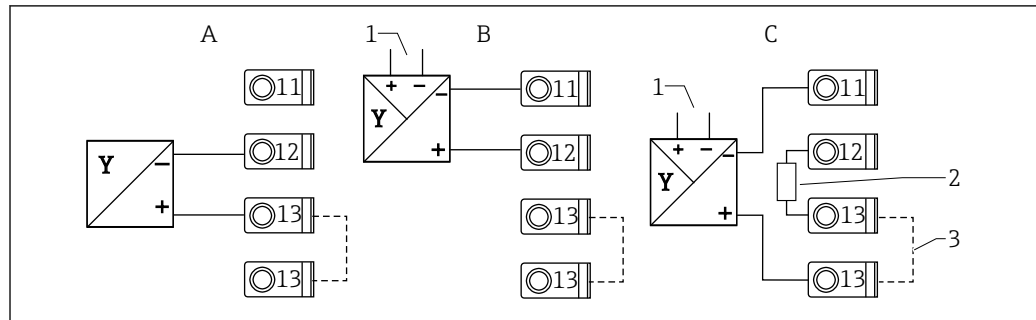

A0056613

23 Connection examples: 2-wire and 4-wire sensor on 4 to 20 mA current input or HART

A Passive 2-wire sensor (LPS switched on), e.g. FMR10B, FMR20B, FMR30B, FMX11, FMX2 1

B Active 4-wire sensor, 4 to 20 mA

C Active 4-wire sensor, HART (LPS switched off)

1 External power supply

2 External HART communication resistor

3 Terminal 13 and 13 jumpered internally

i Observe the relevant Operating Instructions when connecting a sensor.

6.3 Special connection instructions

6.3.1 Connection of the power supply in the polycarbonate field housing

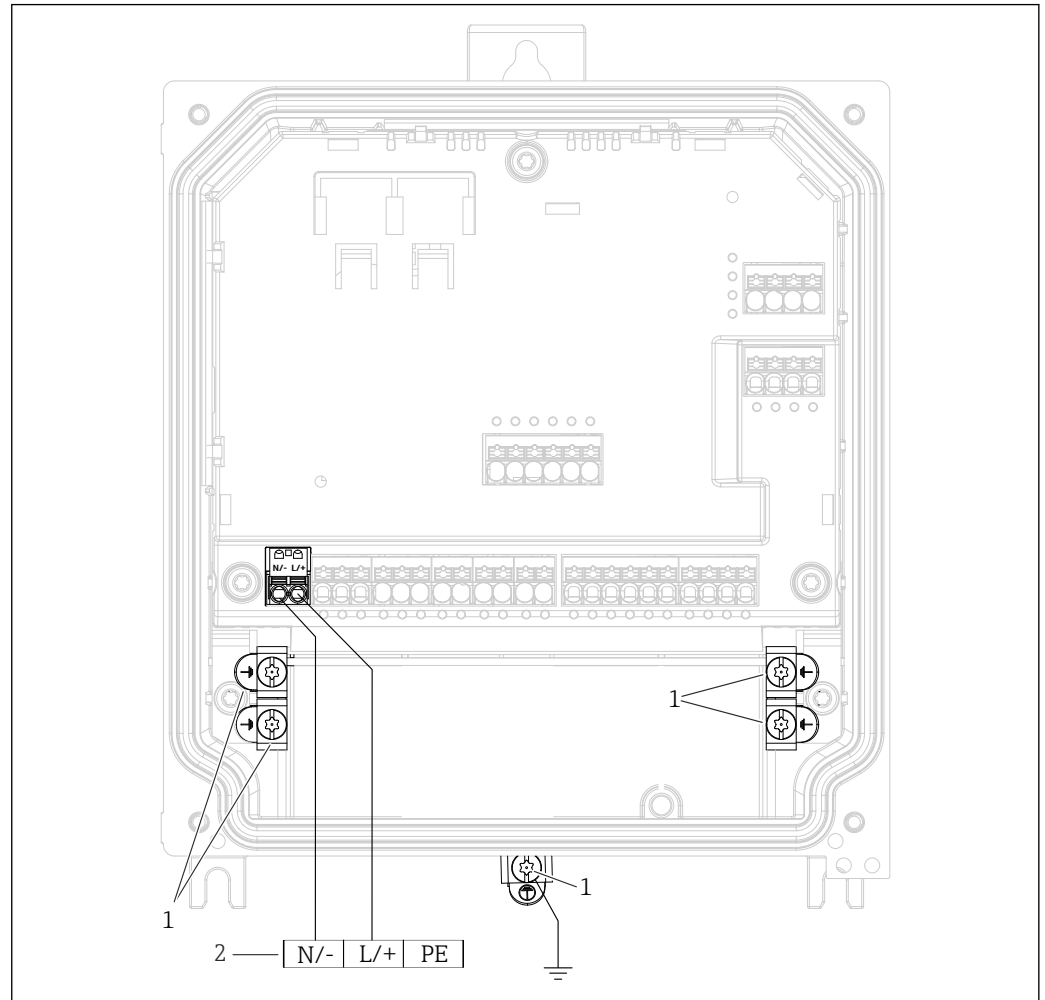

24 Connection of the power supply in the polycarbonate field housing

- 1 Connection options for functional ground and shielding of signal lines
 2 Connection of the power supply (see nameplate)

6.3.2 Connection of the power supply in the aluminum field housing

WARNING

Shock hazard and explosion hazard

- ▶ Connect the aluminum field housing to the potential earth (PE) and/or the local ground potential (PML) via the protective ground terminal.

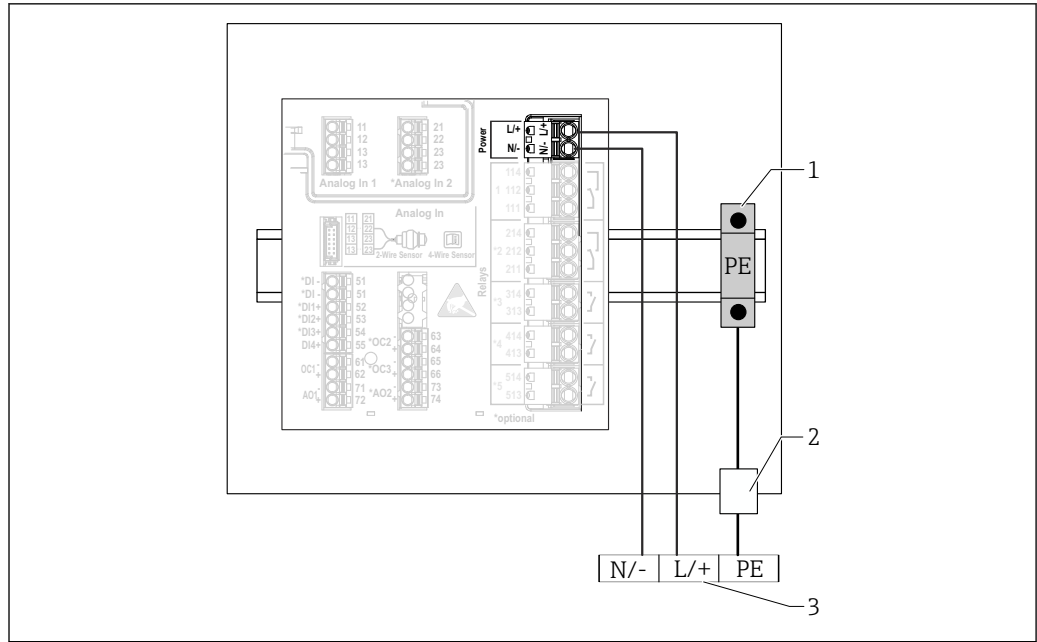

A0054325

25 Connection of the power supply in the aluminum field housing

- 1 Protective ground terminal strip (with contact to DIN rail)
- 2 Protective ground terminal on the outside of the field housing
- 3 Connection of the power supply (see nameplate)

6.3.3 Connection of the power supply on the DIN rail device

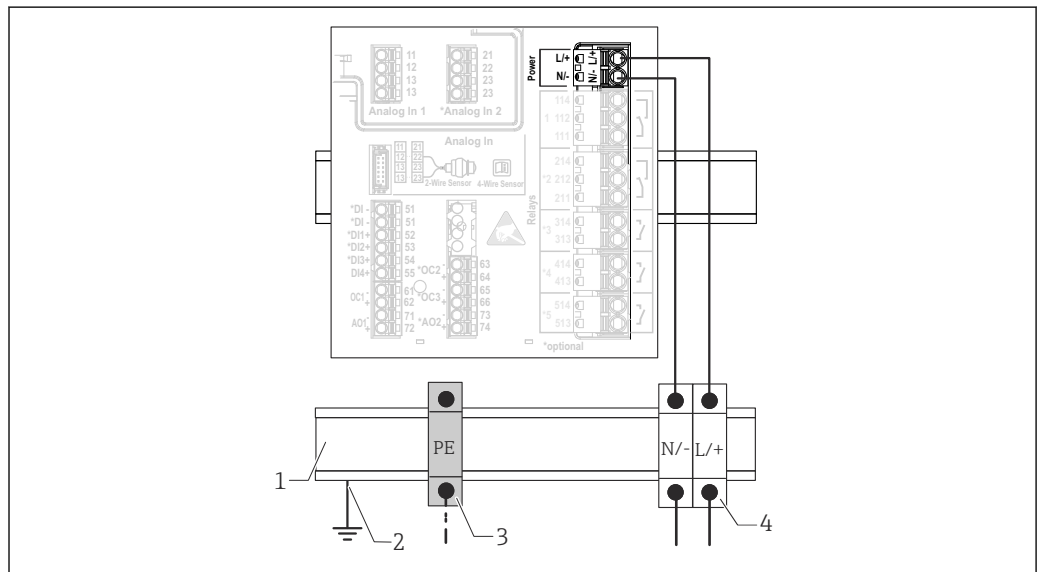

A0054327

26 Connection of the power supply on the DIN rail device

- 1 Metal DIN rail in cabinet
- 2 Grounding via DIN rail
- 3 Protective ground terminal strip (with contact to DIN rail)
- 4 Terminal blocks (no contact with DIN rail); connection of power supply (see nameplate)

6.3.4 Connection of the power supply on the panel-mounted device

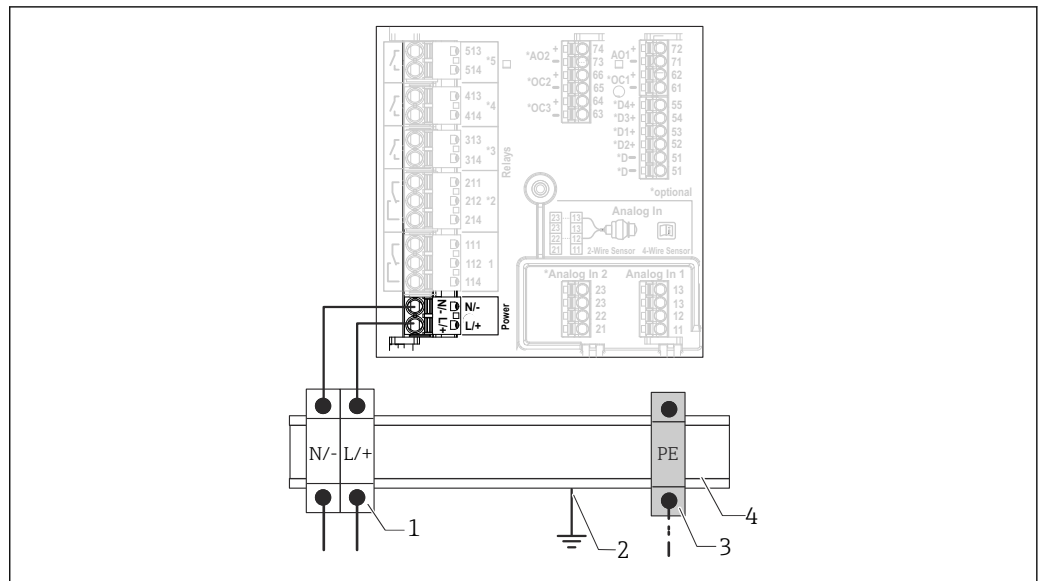

A0054326

27 Connection of the power supply on the panel-mounted device

- 1 Terminal blocks (no contact with DIN rail); connection of power supply (see nameplate)
- 2 Grounding via DIN rail
- 3 Protective ground terminal strip (with contact to DIN rail)
- 4 Metal DIN rail in cabinet

6.4 Hardware settings

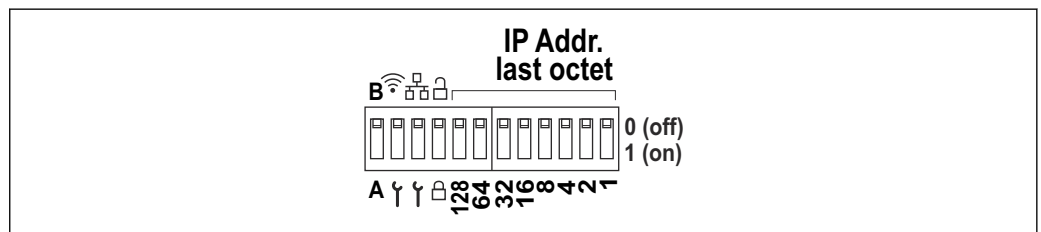

A0051998

28 DIP switch (drawing shows the delivery settings)

The following settings are made at the DIP switch (from left to right):

- A/B: Reserve (currently no function)
- Activate/deactivate the WLAN service IP address (192.168.2.212)
- Activate/deactivate the LAN service IP address (192.168.1.212)
- Write protection switch: locks the device to prevent modifications to the configuration
- 128 to 1: last octet of IP address (192.168.1.xxx) or hardware address for PROFINET

i The LAN and WLAN must not be in the same subnet.

6.5 Ensuring the degree of protection

Only the mechanical and electrical connections which are described in these instructions, and which are necessary for the required intended use, may be established on the device delivered.

6.5.1 DIN rail device

The device meets all the requirements of IP20 protection.

6.5.2 Panel-mounted device

The device fulfills all the requirements for the IP65/NEMA type 4 (front) and IP20 (rear) degree of protection.

Carry out the following steps after electrical connection to ensure the degree of protection:

1. Check that the housing seal to the panel is clean and fitted correctly. Dry, clean or replace the seal if necessary.
2. Tighten all the fastening clips.

6.5.3 Field housing

The field housing fulfills all the requirements for the IP65/NEMA type 4X degree of protection.

Carry out the following steps after electrical connection to ensure the degree of protection:

1. Aluminum field housing: The device must be mounted and connected on a DIN rail in the field housing as described in this manual.
2. Polycarbonate field housing: Check that the housing seal is not damaged. Dry, clean or replace the seal if necessary.
3. Tighten all housing screws and screw covers. (Tightening torque: 1.3 Nm (1 lbf ft))
4. Firmly tighten the cable glands.
5. To ensure that moisture does not enter the cable entry, route the cable so that it loops down before the cable entry ("water trap").

6.6 Post-connection check

Device condition and specifications	Notes
Are the device and cable undamaged (visual inspection)?	-
Electrical connection	Notes
Does the supply voltage match the specifications on the nameplate?	-
Are the power supply and signal cables connected correctly?	-
Are the mounted cables strain-relieved?	-
Are all the connections of the terminals, ground terminals, etc. checked?	-
For field housing: Are the cable glands tightened correctly? Are the cover screws on the connection compartment cover firmly tightened? (Visual inspection)	-

7 Operation options

7.1 Structure and function of the operating menu

7.1.1 Structure of the operating menu

Menu	Typical tasks	Contents/Submenu ¹⁾
Guidance	Main functions for use: From fast and reliable commissioning to guided support during operation.	<ul style="list-style-type: none"> ▪ Commissioning ("Maintenance" only) This wizard guides you through the commissioning of the device. ▪ Certificate management Import of certificates for the web server or other services, as well as the creation of certificates for reliable communication. ▪ Import/Export Option for file import and export via web server
Diagnostics	Troubleshooting and preventive maintenance: Device behavior settings for process and device events and help and measures for diagnostic purposes.	<p>Contains all parameters for detecting and analyzing errors:</p> <ul style="list-style-type: none"> ▪ Active diagnostics Shows the current diagnostic message with the highest priority, the last diagnostic message and the operating time of the device ▪ Diagnostic list Shows the current diagnostic events pending ▪ Event logbook Shows all event messages in chronological order ▪ Minimum/maximum values Shows the lowest and highest electronics temperature measured to date, the minimum/maximum level values linearized to date and the minimum/maximum volume flow rate with the respective timestamps. The values can be reset. ▪ Simulation Simulation of a process variable, a pulse output or a diagnostic event ▪ Diagnostic settings Contains all parameters for configuring error events ▪ HART master Diagnostic information for checking the quality of the HART signal and HART communication

Menu	Typical tasks	Contents/Submenu ¹⁾
Application	Targeted optimization for the specific application: Comprehensive device settings from sensor technology to system integration for optimum application adjustment.	Contains all parameters for commissioning an application: <ul style="list-style-type: none"> ■ Measured values Displays the current measured values and status of the applications ■ Operating mode Use this function to select the operating mode (normal operating mode or configuration mode), as well as the logging interval and the application ■ Units Contains all parameters for configuring the engineering units ■ Sensors Contains all parameters for configuring the sensors ■ Level Contains all parameters for level configuration ■ Pump control Contains all the parameters for configuring pump control ■ Flow Contains all parameters for flow configuration ■ Backwater Contains all parameters for configuring backwater detection ■ Calculations Enables average calculations and totalizers for level and flow ■ Totalizer Enables a reset of the totalizer ■ Rake control Contains all parameters for configuring rake control ■ Digital inputs Contains all parameters for configuring the digital inputs ■ Limit values Contains all parameters for configuring the limit values ■ Current output Contains all parameters for configuring the current outputs ■ HART output (optional) Contains all parameters for configuring the HART outputs ■ Relay Contains all parameters for configuring the relays ■ Open collector Contains all parameters for configuring the open collector outputs
System	Comprehensive device management and security settings: Management of system settings and adjustment to the operating requirements.	Contains all higher-level device parameters that are assigned to system, device and user management. <ul style="list-style-type: none"> ■ Device management Contains all parameters for general device management ■ Security Contains all parameters for device security and user administration ■ Connectivity Contains the parameters for configuring the communication interfaces ■ Web server Contains all parameters for the web server ■ Display Configuration of the on-site display ■ Date/time Configuration and display of date/time ■ Geolocation Configuration of GPS coordinates for the device ■ Information Contains all parameters for unique identification of the device ■ Hardware configuration Overview of the hardware configuration ■ Software configuration Updates, activation and overview of the software
Visualization	Tasks during operation: Create and display groups for the visualization of measured values.	Group 1 to 6 Configuration, display and visualization of the current measured values in groups
Help	Additional information on the device	Displays QR codes with external links (product page, training videos, etc.)

1) The visibility of the submenus depends on the device configuration and the selected ordering options.

 For a detailed overview of all operating parameters, see the associated description of device parameters (GP)

7.2 Access to the operating menu via the local display

The device can be operated intuitively via the 3.5" TFT touch display (order option). Once switched on, the device responds by displaying the start screen. The device is operated using buttons, drop-down lists and input fields. A screen keyboard is available for alphanumeric entries. Drop-down lists and visualization menus (measured value displays) can be operated by swiping vertically/horizontally.

7.2.1 Elements on front of device with touch display

 The device version without display features 3 LEDs: DS (device status), NS (network status) and WLAN status at the bottom left instead of the display

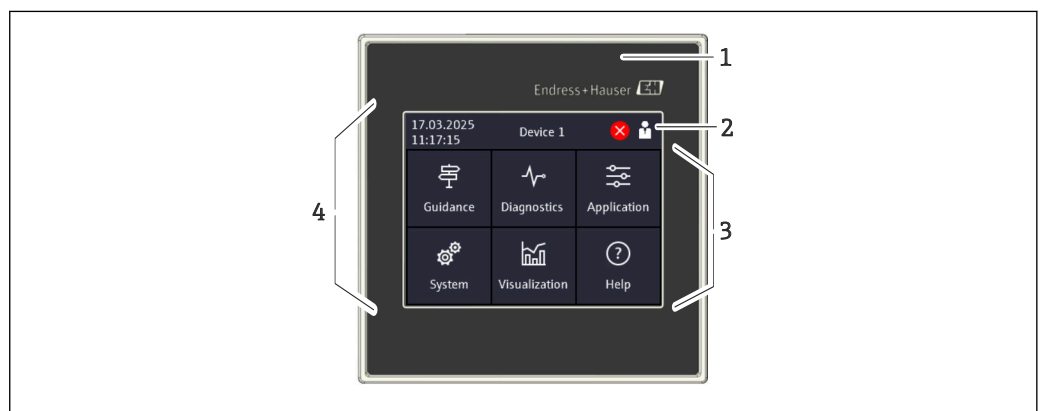

- 1 Front of device
 2 Header: date/time, tag name, diagnostic information, quick access menu (logging in/log out, language)
 3 Function tiles for display and touch operation
 4 Touch display

7.2.2 Light emitting diodes (LEDs)

 The LEDs are only visible with the DIN rail version without touch display.

DS (device status): LED for operating status

- **Lit green**
Normal operation; no faults detected.
- **Flashes red**
Warning is pending. Details are saved in the diagnostic list.
- **Lit red**
Alarm is pending. Details are saved in the diagnostic list.
- **Off**
No supply voltage.

NS (network status): LED for Ethernet fieldbus

- **Lit red**
Communication active
- **Lit green**
Connection established, no active communication
- **Off**
No connection

WLAN: LED for communication

- **Flashing blue**
Searching for WLAN access point
- **Lit blue**
Connection established
- **Off**
No connection

7.2.3 Operation via touch display

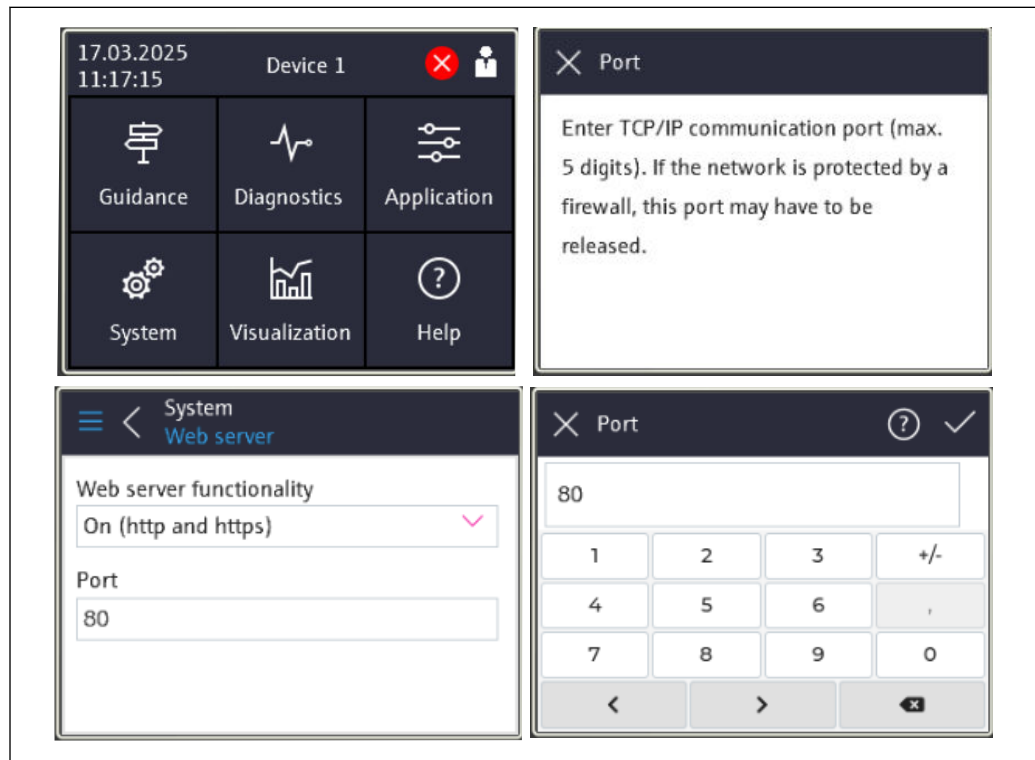

29 Operating menu on the touch display: Start screen, submenu with input fields, screen keyboard, online help

- i** The ✓ symbol with the "OK" or "Confirm entry" function appears in the top right of each dialog box.
The value is accepted and the dialog box closes by clicking ✓.
- i** The ✕ symbol with the "Back" or "Cancel" function appears in the top left of each dialog box.
Pressing ✕ closes the dialog box without accepting the value entered.
- i** Help: The ? symbol appears in the top right of each dialog box and can be used to call up the integrated help function.
Pressing ✕ closes help.

7.3 Access to the operating menu via web browser

The integrated web server can be used to operate and configure the device via a web browser. The web server is enabled when the device is delivered, but can be disabled via an appropriate parameter. Access to the web server always requires entering a PIN. For device versions with Industrial Ethernet communication types, the connection can be established at the signal transmission port via the network.

Function range

Thanks to the integrated web server, the device can be operated and configured using a web browser via the LAN or WLAN interface. The structure of the operating menu is the same as for the local display. In addition to the measured values, status information on the device is displayed which can be used to monitor device health. Furthermore the device data can be managed and the network parameters can be configured.



A device which has a WLAN interface (optional) is required for the WLAN connection.

7.4 Access to the operating menu via operating tools

7.4.1 Access to the operating menu via Field Xpert SMT70

Function range

Field Xpert for mobile plant asset management is available as both a tablet PC and an industrial PDA with an integrated touch screen for the commissioning and maintenance of devices in hazardous and non-hazardous areas. This enables efficient device configuration. Communication is wireless via the WLAN interface (optional).



Source for device description files: Refer to the information in the "System integration" section of the Operating Instructions.

8 System integration

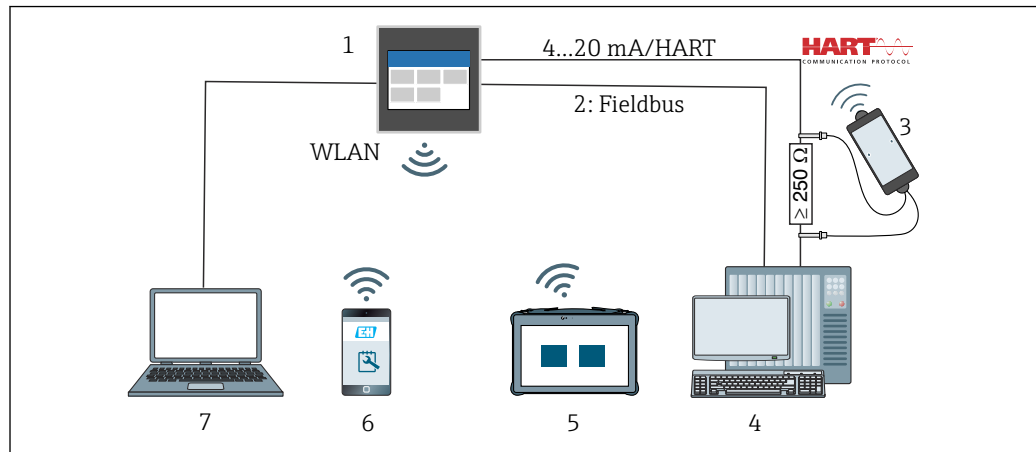

30 System integration

- 1 FlexView FMA90
- 2 Fieldbus: communication via Ethernet fieldbus to PLC (optional)
- 3 Optional: HART modem with connecting cable, e.g. Commubox FXA195 or VIATOR Bluetooth (restricted operation)
- 4 Optional: PLC via HART protocol (FDI package, restricted operation)
- 5 Field Xpert SMT70 via WLAN and web server
- 6 Operation and configuration via WLAN and web server
- 7 Operation and configuration via Ethernet and web server

8.1 Measured variables via HART protocol (slave)

It is possible to change the assignment of device variables to process variables in the **Application → HART output → Process variables** menu.

Detailed overview of all device variables: see the corresponding description of Device Parameters (GP)

8.2 Supported HART commands (slave)

The integrated HART slave of the device supports the following commands:

Command No.	Name
Universal commands	
0, Cmd0	Read unique identifier
1, Cmd001	Read primary variable
2, Cmd002	Read loop current and percent of range
3, Cmd003	Read dynamic variables and loop current
6, Cmd006	Write polling address
7, Cmd007	Read loop configuration
8, Cmd008	Read dynamic variable classifications
9, Cmd009	Read device variables with status
11, Cmd011	Read unique identifier associated with TAG
12, Cmd012	Read message
13, Cmd013	Read TAG, descriptor, date
14, Cmd014	Read primary variable transducer information
15, Cmd015	Read device information

Command No.	Name
16, Cmd016	Read final assembly number
17, Cmd017	Write message
18, Cmd018	Write TAG, descriptor, date
19, Cmd019	Write final assembly number
20, Cmd020	Read long TAG (32-byte TAG)
21, Cmd021	Read unique identifier associated with long TAG
22, Cmd022	Write long TAG (32-byte TAG)
38, Cmd038	Reset configuration changed flag
48, Cmd048	Read additional device status
Common practice commands	
33, Cmd033	Read device variables
35, Cmd035	Write primary variable range values
40, Cmd040	Enter/Exit fixed current mode
44, Cmd044	Write primary variable units
45, Cmd045	Trim loop current zero
46, Cmd046	Trim loop current gain
50, Cmd050	Read dynamic variable assignments
51, Cmd051	Write dynamic variable assignments
54, Cmd054	Read device variable information
59, Cmd059	Write number of response preambles
60, Cmd060	Read analog channel and percent of range
63, Cmd063	Read analog channel information
72, Cmd072	Squawk
95, Cmd095	Read Device Communication Statistics
100, Cmd100	Write Primary Variable Alarm Code
226, Cmd226	Firmware version string
227, Cmd227	Serial number string
228, Cmd228	Extended order code string
231, Cmd231	Device status
233, Cmd233	Order code string
234, Cmd234	ENP version string
236, Cmd236	Start-up time
516, Cmd516	Read Device Location
517, Cmd517	Write Device Location
518, Cmd518	Read Location Description
519, Cmd519	Write Location Description
520, Cmd520	Read Process Unit Tag
521, Cmd521	Write Process Unit Tag
523, Cmd523	Read Condensed Status Mapping Array
524, Cmd524	Write Condensed Status Mapping Array
525, Cmd525	Reset Condensed Status Mapping Array
526, Cmd526	Write Simulation Mode

Command No.	Name
527, Cmd527	Simulate Status Bit
Device Specific Commands	
194, Cmd194	Read Parameter via HART Index
195, Cmd195	Write Parameter via HART Index
226, Cmd226	Firmware version string
227, Cmd227	Serial number string
228, Cmd228	Extended order code string
231, Cmd231	Device status
233, Cmd233	Order code string
234, Cmd234	ENP version string
236, Cmd236	Start-up time

8.3 Open-source license information

This product contains software components that are licensed by the copyright owners as free or open-source software under the GNU General Public License (Version 2.0 or 3.0) or the GNU Lesser General Public License (Version 2.1 or 3.0). The source code of these software components is available on a data medium (USB memory stick). This offer is valid for a period of 3 years after the last transmission of the object code by the manufacturer. Furthermore, its validity is limited to the period during which the manufacturer offers spare parts or customer support.

Proceed as follows to download the **open-source license information** (*.txt): Access the device via web server and select the **Guidance -> Import/Export -> License information -> Start** menu.

To request the **source code**, send an e-mail to the manufacturer's local service address. Please also send the following information:

- Address to which the storage medium with the source code should be sent.
- Product information (product name, serial number).

On request, the source code will be sent to the specified address, subject to reimbursement of the actual costs of providing the storage medium and postage.

9 Commissioning

9.1 Post-installation check

Make sure that all installation and connection checks have been carried out before putting the device into operation.

NOTICE

- ▶ Before commissioning the device, make sure that the supply voltage matches the voltage specifications on the nameplate. Failure to perform these checks may result in damage to the device caused by the incorrect supply voltage.

9.2 Switching on the device

Once the supply voltage has been applied, the display or the status LED indicates that the device is ready for operation.

If you are commissioning the device for the first time, program the setup as described in the following sections.

If you are commissioning a device that is already configured or preset, the device starts measuring immediately as defined in the settings. The values of the channels currently activated are shown on the touch display.

 Remove the protective film from the touch display as this will otherwise affect the readability of the display.

9.3 Configuring the operating language at the device

Factory setting: English or local language ordered

(Only relevant for version with touch display)

You can change the language under "Language" using the quick access menu at the top right in the header.

1. Select the required language from the "Language" drop-down list
2. Confirm selection by pressing "✓" in the top right

The operating language has been changed.

9.4 User management and permissions

The access control concept consists of several hierarchical levels for different users. User management reflects the various requirements with specific read and write rights.

Settings are configured in the **System** → **Security** menu.

■ **Operator** (logged-out status)

An **operator** can only change settings that have no effect on the application. The operator is able to read most of the parameters, however.

■ **Maintenance (factory setting)**

A **Maintenance** role is assigned to the device configuration. It is possible to change the most important parameters.

■ **Service** (exclusively for the manufacturer's service technicians)

The **Service** role is primarily intended for diagnostics and troubleshooting. It allows configuration and modification of the relevant parameters.

■ **Production**

Internal account for service cases and repair Deactivated in delivery state, can only be activated by the customer's maintenance technician.

■ **Developer**

Internal account for service cases and repair Deactivated in delivery state, can only be activated by the customer's maintenance technician.

⚠ CAUTION

Conductive objects such as needles or office clips can cause electrical accidents.

- ▶ Use a non-conductive tool.
- ▶ Do not insert in ventilation slots etc.
- ▶ Only insert the tool into the opening of the reset button.

Functions of the button:**■ Press once briefly (1s): restart device**

The device is restarted.

■ Press 4 times briefly: Reset User Accounts

The PINs for the maintenance and operator roles are deleted; the web server is enabled. A diagnostic message is displayed.

■ Press once and hold down (12s): Decommissioning Reset

The device is reset to factory settings. Pins, logbooks, measured values, analyses, counters, RAM and certificates are deleted.

 After the reset, the device restarts.

 Before returning a device or disposing of it, perform a "Decommissioning Reset" to ensure that stored data cannot be misused.

9.5 Configuring the device

Further configuration of device parameters can be carried out directly via the touch display or the web server.

 For a detailed overview of all operating parameters, see the associated description of device parameters (GP)

 Flow calculation of customer-specific flumes and weirs: See the associated Special Documentation (SD)

NOTICE**Avoiding incorrect configuration**

- ▶ Do not configure the device simultaneously via various interfaces (LAN/WLAN/touch). The device does not restrict this to facilitate (on-site) operation even in emergency situations.
- ▶ If using a device that has already been used and is not brand new from Endress+Hauser Sensors, it is recommended to perform a factory reset before commissioning.

⚠ CAUTION**Undefined switching of outputs and relays**

- ▶ During configuration, the device may assume undefined states! This may result in the undefined switching of outputs (relays/OC) and the output of a failure current (current outputs).
- ▶ To counteract this, configuration mode can be activated in the **Guidance** → **Commissioning** menu or via **Application** → **Operating mode** → **Configuration mode**. This ensures that the current states of the outputs (relays/OC) are retained during configuration.

i Configuration via wizard

For quick and easy commissioning, we recommend you carry out device configuration using the integrated wizard. The wizard can be called up directly via the touch display, the web server and all the operating tools (restricted).

Can be called up in **Guidance** → **Commissioning** menu

The wizard guides you through the commissioning of the device. A suitable value can be entered or the appropriate option selected for each parameter.

The following wizard is stored in the device:

- Device settings
- Application
- Outputs
- Visualization

If multiple applications are to be configured in combination, manual configuration must be selected.

If the wizard is canceled before all the necessary parameters have been configured, any settings already set are saved. For this reason, the device may then be in an undefined state. In such situations, it is advisable to reset the device to the factory default settings.

- i** Certain parameters are preset for the operation of the FMA90 in conjunction with Endress+Hauser sensors and are always defined by the FMA90.

9.5.1 Setup via touch display

- i** Recommendation:

In the **Guidance** → **Commissioning** menu: As a component in the guided device operation (Wizard)

In the **System** menu: Configure basic device settings such as language, date/time, communication etc.

In the **Application** menu, configure settings for the application in question

9.5.2 Establishing a connection and setup via web server

The device features an integrated web server, which enables access via Ethernet or WLAN. The web server is used for convenient device commissioning and configuration and to visualize measured values. Access is possible from any access point when the device is connected to an Ethernet network. Suitable IT infrastructure, security measures, etc. must be provided according to system-specific requirements. For service purposes, point-to-point access via web server and Ethernet is particularly suitable.

Establishing a connection via WLAN (option)

 The WLAN access data and applicable radio approvals are affixed to the housing on devices with the WLAN option.

For quick and easy connection during initial commissioning, scan the matrix code (QR) located there with a mobile device.

Setting up a connection manually:

Carry out the following steps to connect to the device via WLAN:

1. Network information: The information on the WLAN MAC address, network name (SSID) and network key WLAN password) is located outside the device.
2. Enable WLAN on the device under **System** → **Connectivity** → **WLAN** → **Configuration** → **WLAN** (= factory setting). Confirm changes with "Apply".
3. Enable WLAN on the mobile device: Enable the WLAN in the settings for the device to be connected (e.g. laptop, smartphone).
4. Select network: In the list of available networks, search for the network name (SSID) provided by the device.
5. When prompted, enter the network key (WLAN password) provided on the device (case-sensitive).
6. Connect: Click "Connect" or a similar button to connect to the WLAN network.

 If you have problems connecting, check that the password is correct, check the range of the WLAN network for the device and restart the router and the device if necessary.

It is recommended to change the network key for the WLAN after the device has been set up. For security, use a combination of upper and lower case letters, numbers, and symbols. Note: After this change, the matrix code (QR) on the device is no longer valid.

We recommend you disable the "Connect automatically" function for this network on the mobile device (e.g. laptop, smartphone), as otherwise the terminal will inadvertently connect to the device instead of the company network.

Establishing a connection via Ethernet

The device is equipped with one or two (order option) RJ45 Ethernet ports. They can be used to build point-to-point, star or ring topologies. Both RJ45 ports are identical in terms of their functionality.

 A crossover cable is not required.

When connecting via LAN to a company network: please contact your system administrator.

The LAN and WLAN must not be in the same subnet.

Device version with touch display

Procedure to establish a direct connection via Ethernet (point-to-point connection):

1. Retrieve the Ethernet settings such as IP address etc. on the device under **System** → **Connectivity** → **Ethernet** → **Information**
2. Disable DHCP on the device under **System** → **Connectivity** → **Ethernet** → **Configuration**
3. Connect the PC to the device using a LAN cable
4. Set the IP address on the PC (network part: octets 1 to 3 must match the device; host part: octet 4 must differ, e.g. 192.168.1.213)
5. Set the subnet mask on the PC: 255.255.255.0

Device version without touch display

Procedure to establish a direct connection via Ethernet (point-to-point connection):

-  Note: The following activation of the LAN Service IP address via DIP switch will interrupt communication to the network!
- 1. Activate the service IP address 192.168.1.212 using DIP switch 3 on the device
- 2. Connect the PC to the device using a LAN cable
- 3. Set the IP address on the PC (network part: octets 1 to 3 must match the device; host part: octet 4 must differ, e.g: 192.168.1.**213**)
- 4. Set the subnet mask on the PC: 255.255.255.0

Setup via web server

To activate the web server: go to the menu **System** → **Web server** → **Web server functionality** → **On (http and https)** (factory setting)

The web server port is preset to 80. The port and the language of the web server can be changed directly in this menu. The factory setting of the language is English.

-  To establish a secure https connection to the web server, a corresponding X.509 certificate must be stored on the device.

Certificate management is available under **Guidance** → **Certificate management**.

For more information on certificate management: Refer to the following section, as well as the Description of Device Parameters (GP)

-  If the network is protected by a firewall, the port may need to be activated.

-  Authentication as operator is required to configure the device via web server ("Operator" or "Maintenance"). The initial device PIN for both accounts is **0000**.

PIN management is available under **System** → **Security**.

Note: The initial device PIN should be changed during commissioning!

-  In order to use the full functionality of the Web server, it is recommended that the latest version of the browser is used.

A minimum resolution of 1920x1080 (full HD) is recommended.

-  It is not possible to access the web server from multiple devices simultaneously via both WLAN and Ethernet.

Establishing a connection to the web server:

1. Connect the PC with the device via Ethernet or WLAN (optional). Pay attention to the DIP switch settings!
2. Start the browser on the PC or on the mobile device
3. Enter the device's IP address in the browser **http://<ip address>** or **https://<ip address>**. Note: Leading zeros in IP addresses must not be entered. **LAN: 192.168.1.212, WLAN: 192.168.2.212**
4. Select "Maintenance" (for parameter configuration) or "Operator" user ID, enter the device PIN and confirm with "Login".

The web server responds with the start screen and device operation or parameter configuration can be started.

Example: certificate management in Windows

-  Certificate management should preferably be handled by an IT/network administrator ("intermediate certificate").

Alternatively, a "root certificate" can be implemented, see the following example.

Access via HTTPS to the device's web server requires valid certificates.

Process:

- Create a root certificate on the Windows PC and save it in Windows certificate management. This certificate will later sign the device certificate.
- Create a certificate signing request file (CSR) on the device.
- Sign the CSR file on the Windows PC.
- Import the signed certificate into the device.

Details on carrying out the steps (example)

1. Preparation on the Windows PC:

- Install OpenSSL
- Create private key:
`openssl genrsa -out myRoot.key 4096`
- Create root certificate:
`openssl req -x509 -new -nodes -key myRoot.key -sha256 -days 3650 -out myRoot.crt`
When entering the certificate data, make sure to set a unique common name (CN), e.g., `myRootCRT20260112`
- Save the root certificate in Windows
Right-click on the "myRoot.crt" file to open and select the "Install certificate" option.
Select a location such as "This PC".
Select "Place all certificates in the following store" **Browse** → **Trusted Root Certification Authorities**
Complete the installation with "Next" and "Finish".

2. Create the CSR in the device's web server

- Open the **Guidance** → **Certificate management** → **Create CSR (Certificate)** menu.
- Select the **Web server certificate** type and complete the fields where necessary.
- Select "Next" → **Create CSR (Certificate)**, and press "Next" again.
- Click "Start" to download the CSR file onto the PC, e.g.: `FMA90_SERIALNR_date_time.csr`

3. Sign the CSR on the Windows PC (or have your IT department sign it)

- Create Config file
Create a file, e.g., "FMA90.cnf" with the following content (example):
`[req]`
`prompt = no`
`req_extensions = v3_req`
`x509_extensions = v3_ca`
`[req_distinguished_name]`
`[v3_req]`
`basicConstraints = CA:FALSE`
`keyUsage = nonRepudiation, digitalSignature, keyEncipherment`
`[v3_ca]`
`subjectKeyIdentifier=hash`
`authorityKeyIdentifier=keyid:always,issuer`
`basicConstraints = critical,CA:false`
`[subject_alt_name]`
- Execute the command to sign the CSR:
`openssl x509 -req -days 360 -in FMA90_SERIALNR_date_time.csr -CA myRoot.crt -CAkey myRoot.key -CAcreateserial -out FMA90_signed.crt -sha256 -extfile FMA90.cnf -extensions v3_ca -copy_extensions=copy`

4. Import the signed certificate into the device

- Open the **Guidance** → **Certificate management** → **Import certificate** menu.
- Upload the "FMA90_signed.crt" file. Check the box to the right of the file name.
- Complete import with **Next** → **Finish**.

Checkinf

- Check if the imported certificate is listed in the **System** → **Security** → **Certificates** menu.
- Using "https://...", call up the device's web server from the Windows PC. The login page must appear.

9.6 Application examples

 Flow calculation of customer-specific flumes and weirs: See the associated Special Documentation (SD)

For a detailed overview of all operating parameters, see the associated description of device parameters (GP)

9.6.1 Application examples for level measurement**Level measurement and alarm output**

The level is recorded with the sensor. Limit values can be used to define minimum and maximum values and switch relays accordingly. Linearization must be set to "on" for the level to be passed on.

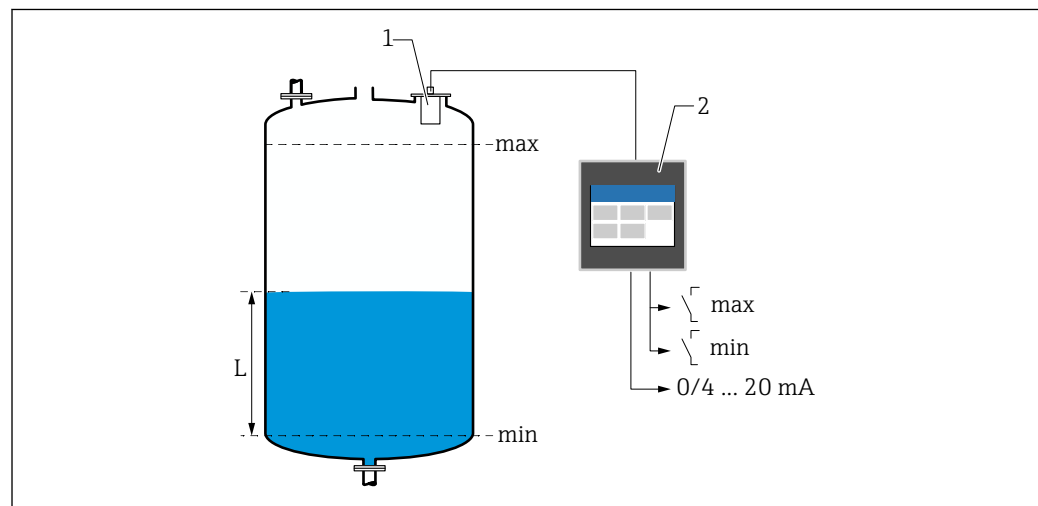

 32 Level measurement and alarm output

1 Level sensor (e.g. radar or ultrasonic sensor)

2 FlexView FMA90

L Level

Level linearization*Pre-programmed linearization curves*

- None (the sensor value is adopted directly)
- "Linear" cylindrical tank
- Horizontal cylindrical tank
- Spherical tank
- Tank with pyramid bottom
- Tank with conical bottom
- Tank with flat angled bottom

Linearization table

- Manual entry
- Up to 32 linearization points "Level - Volume". A linearization table can be created on the device or via the web server using editors. This table can be imported and exported as a CSV file (backup) in the web server.

Rake control (differential measurement)

Two sensors measure the levels before the rake (= upstream water level) and after the rake (= downstream water level). If the rake is dirty, the difference between the levels increases and the relays can be switched accordingly for rake control.

The rake control can operate in two modes: Difference: upstream water level – downstream water level or Ratio downstream water level / upstream water level

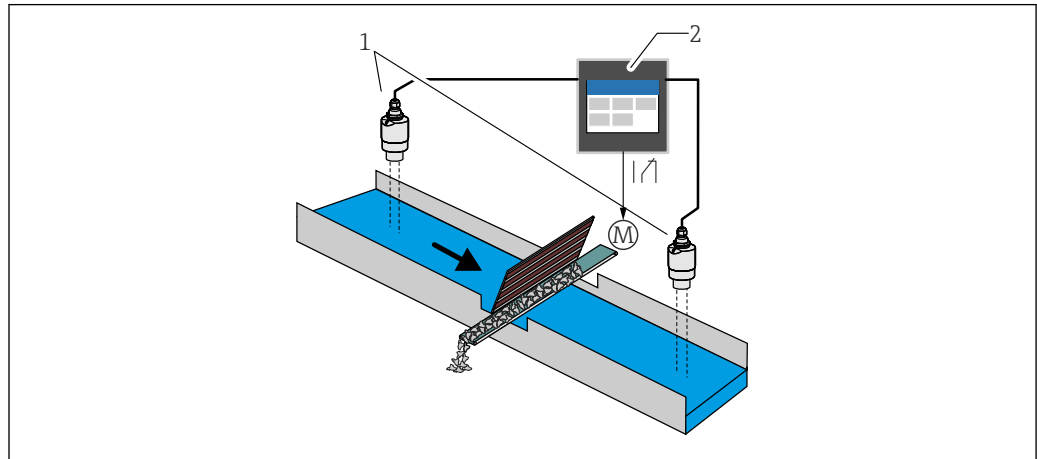

A0052673

33 Rake control (differential measurement)

- 1 Level sensors (e.g. Radar or ultrasonic sensor). Left sensor: upstream water level; right sensor: downstream water level
- 2 FlexView FMA90
- M Motor for rake control

Pump control

Via the pump control, up to eight pumps can be controlled individually or in groups based on the level, the status of digital inputs and/or the time. Additional functions for pump control are individually configurable. Each pump control can be operated in 2 modes: limit value control or pump rate control.

On 2-channel devices, two individual pump controls can be activated.

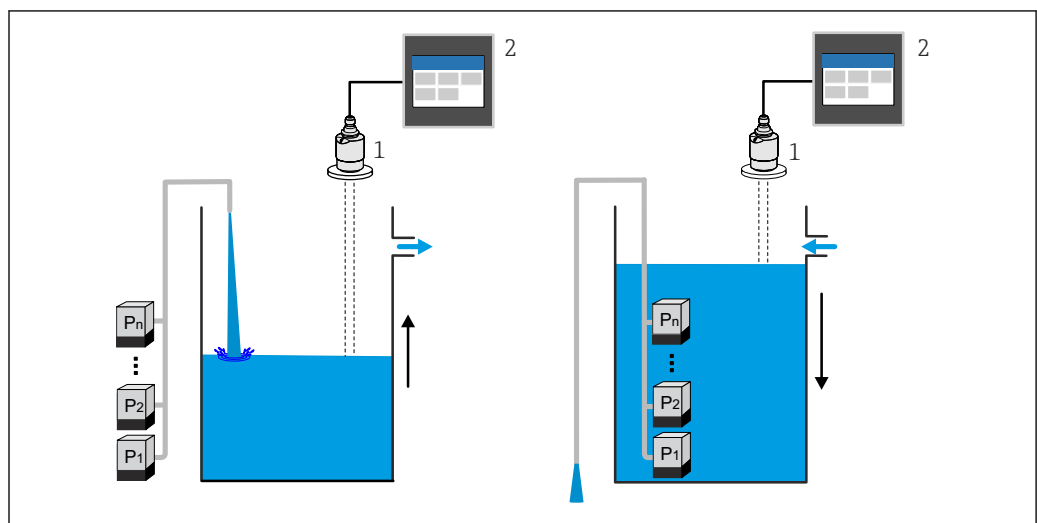

A0052674

34 Pump control for up to eight pumps. Example on the left: Filling; on the right: Emptying

- 1 Level sensor (e.g. radar or ultrasonic sensor)
- 2 FlexView FMA90

Individually configurable for each pump:

- Pump switching delay
E.g. to prevent overload of the power supply system.
- Pump run-on times and intervals
E.g. for complete emptying of shafts or channels.
- Reduction of buildup on pump chamber walls by fine adjustment of the switch point
E.g. variably changing level.

Further functions:

- Alternation in sequence/according to defined load.
E.g. for protecting individual pumps, or pumps with the same load.
- Limit control
Individual operation/parallel operation/pump group.
- Pump rate control
Pumps are switched on automatically one by one until the minimum pump rate or switch-off point is reached.
- Tariff control
Control of pumps according to electricity tariff.
- Storm function
The storm function is used to prevent the unnecessary operation of the pumps if the plant is flooded for a short time (e.g. in the event of strong rainfall).
- Flush control
The flushing function enables a relay to be switched on for a certain number of flush cycles for a specific flushing duration, e.g. to inject water into the container in order to dissolve/prevent sedimentation at the bottom of the container.
- Function test
Pumps that have been switched off for too long are automatically switched on for a certain amount of time with the function test in order to avoid standing damage.
- Operating data recording
Display of operating data such as operating hours since the last reset, total operating hours, number of starts since the last reset, starts per operating hour since the last reset, number of run-on starts since the last reset, runtime of the last switch-on (pump is off)/since switch-on (pump running), downtime (last downtime if pump on/since switch-off if pump off).
- Operating hours alarm
E.g. alarm goes off if the operating hours of a pump are exceeded.
- Pump feedback
E.g. for indicating the pump status using a digital input.

9.6.2 Application examples for flow measurement

Flow measurement at flumes or weirs

A level sensor measures the level at the inlet of a flume or weir. The corresponding flow is calculated using pre-programmed or freely selectable linearization curves. If a critical value is exceeded or fallen short of, an alarm can be generated or a relay can be switched.

On 2-channel devices, two individual flow measurements can be activated.

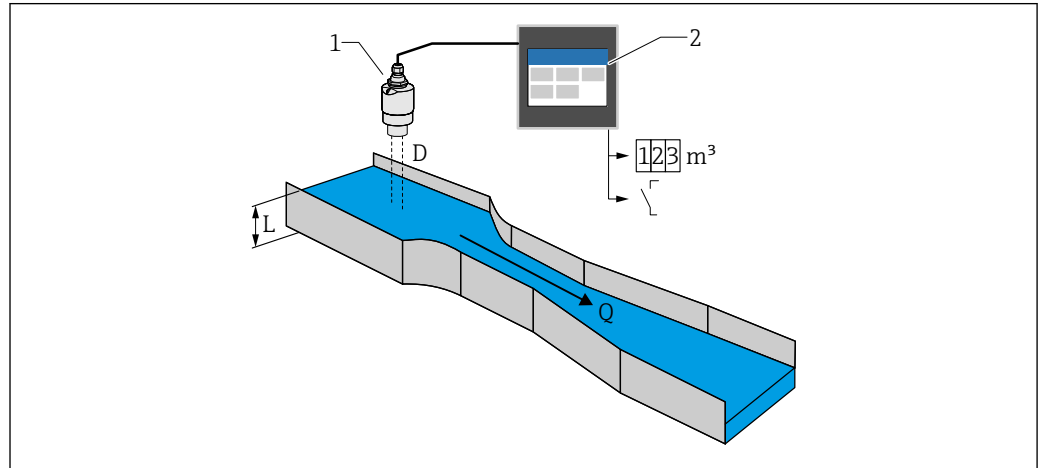

A0056304

35 Flow measurement at flumes or weirs

- 1 Level sensor (e.g. radar or ultrasonic sensor)
- 2 FlexView FMA90
- D Distance between sensor membrane (reference point) and surface of liquid
- L Level
- Q Flow

The level L is derived from D. With linearization, the flow Q is derived from L.

Flow linearization

Pre-programmed linearization curves

Pre-programmed open flumes:

- Khafagi-Venturi flume
- ISO Venturi flume
- Parshall flume
- Palmer-Bowlus flume
- Trapezoidal flume according to ISO 4359:2022
- Rectangular flume according to ISO 4359:2022
- Leopold-Lagco flume
- Cutthroat flume
- U-shaped flume according to ISO 4395:2022
- H-flume

Pre-programmed weirs:

- Trapezoidal weir
- Circular-crested horizontal weir according to ISO 4374:1990
- Broad-crested weir according to ISO 3846:2008
- Thin-walled rectangular weir according to ISO 1438:2017
- Thin-walled triangular weir according to ISO 1438:2017



The pre-programmed linearization curves are stored in the device.

Standard formula for flow measurement

$$Q = C (h^a + \gamma h^b)$$

- h : Upstream level
- α, β, γ, C : User-definable parameters

Other supported calculations

- Ratiometric calculation
- Pipe profile (Manning)
- Linearization table with 32 points A linearization table can be created on the device or via the web server using editors. This table can be imported and exported as a CSV file (backup) in the web server.

Backwater detection (differential measurement)

Two level sensors measure the level at the inlet and outlet of a flume or weir. If the "downstream level : upstream level" ratio exceeds a critical value, an alarm is generated.

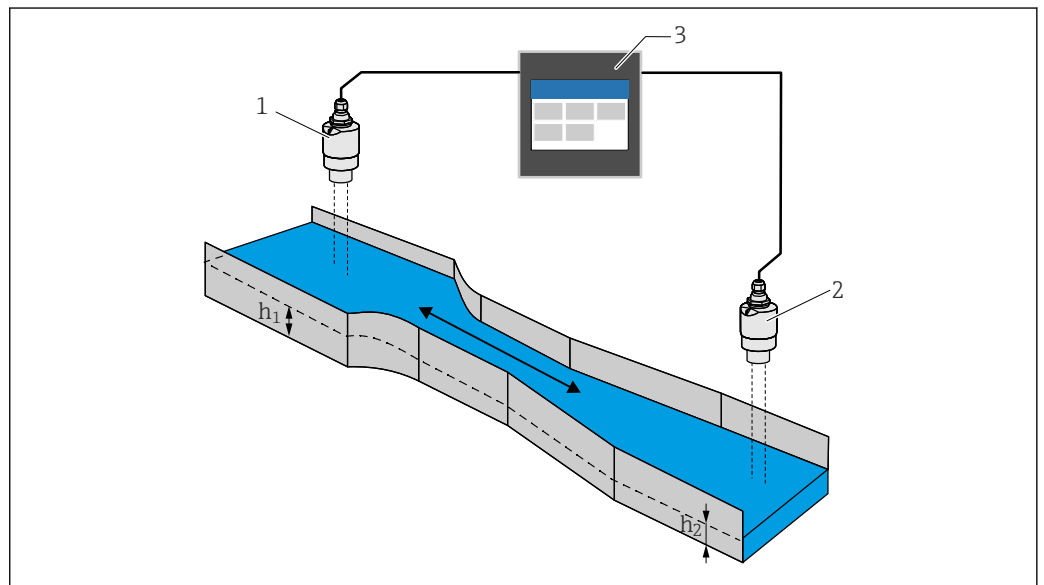

36 Backwater detection

- 1 Upstream sensor (e.g. radar or ultrasonic sensor)
- h_1 Upstream level
- 2 Downstream sensor (e.g. radar or ultrasonic sensor)
- h_2 Downstream level
- 3 FlexView FMA90

Stormwater overflow basin

A level sensor measures the level L . Using the integrated applications for the weirs, the overflow quantity Q can be calculated and stored in a totalizer. If a critical value is exceeded, an alarm can be generated or a relay can be switched.

Low flow cut off can be activated at the device, which sets the output value to 0 when a customer-specific flow value is fallen short of. This prevents downstream totalizers from further integrating the flow.

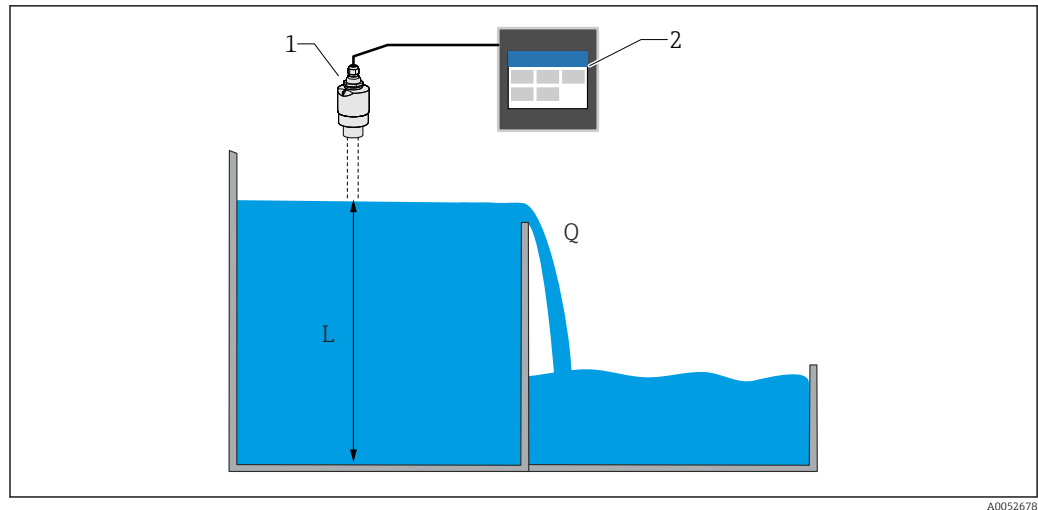

A0052678

37 Stormwater overflow basin

- 1 Level sensor (e.g. radar or ultrasonic sensor)
- 2 FlexView FMA90
- L Level
- Q Overflow quantity

Totalizer + pulses (e.g. for samplers)

A level sensor measures the level at the inlet of a flume or weir. The corresponding flow is calculated using pre-programmed or freely selectable linearization curves. Using a pulse output (relay, open collector), the device can trigger additional systems such as wastewater samplers for example, with the flow-proportional volume signal.

Low flow cut off can be activated at the device, which sets the output value to 0 when a customer-specific flow value is fallen short of. This prevents downstream totalizers from further integrating the flow.

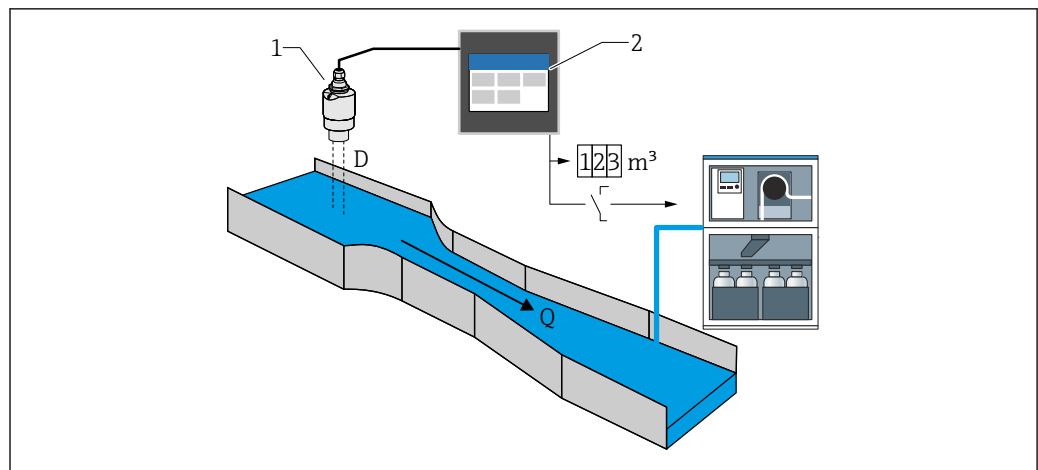

A0053161

38 "Totalizer + pulses" function, e.g. for samplers on flumes or weirs

- 1 Level sensor (e.g. radar or ultrasonic sensor)
- 2 FlexView FMA90
- D Distance between sensor membrane (reference point) and surface of liquid
- Q Flow

9.7 Creating visualization groups

Selection of different layout options for displaying measured values in one group. Up to 6 visualization groups can be created and displayed, each with a maximum of 4 process

values with or without graphics. Preformatted screen displays, such as curve charts, vertical bar graphs or digital displays are possible.

 A user must be logged in as "Maintenance".

 For a detailed overview of all operating parameters, see the associated description of device parameters (GP)

Creating a visualization group using the commissioning wizard:

1. Navigation: **Guidance** → **Commissioning** → **Visualization**
2. Select the desired values using the wizard

Creating and editing a visualization group manually:

1. Navigation: **Visualization** → **Group 1 to 6**
2. Select **+ Group**
3. Customize the group using the pencil icon (description, layout, value 1-4, process variable, color, graphic)

9.8 Simulation

CAUTION

The output corresponds to the simulated value or event.

- ▶ During simulation, the device may assume undefined states! This may result in the undefined switching of outputs (relays/open collector) and the output of a failure current (current outputs).

9.8.1 Simulation of sensor inputs

Navigation

- For sensor 1:
Diagnostics → Simulation → Sensor 1 simulation
- For sensor 2:
Diagnostics → Simulation → Sensor 2 simulation

Parameters

- **Simulation**
Select process variable for simulation, which is thereby activated. Selecting 'Off' will deactivate the simulation.
- **Current**
Enter current value as process variable for simulation.
- **HART value**
Enter HART value (PV) as process variable for simulation.
- **Level 1 or 2**
Enter level value as process variable for simulation.
- **Level 1 or 2 linearized**
Enter linearized level value as process variable for simulation.
- **Flow 1 or 2**
Enter flow value as process variable for simulation.

9.8.2 Simulation of current output

Navigation

Diagnostics → Simulation → Current output 1 or 2 simulation

Parameters**■ Current output 1 or 2 simulation**

'On' The current simulation is active. The output current does not correspond to the measured value but to the value defined in the 'Value current output' parameter.

'Off' The current simulation is not active. The output current corresponds to the measured value.

■ Value current output 1 or 2

Defines the value of the simulated output current.

Note: On activation, the simulation value is initialized with the current output.

9.8.3 Digital output simulation**Navigation**

Diagnostics → Simulation → Digital input → Digital output simulation

Parameters**■ Simulation relay 1 to 5**

Switch simulation relay on and off.

Additional information: Selection of the switching state to be simulated: 'Switched on' (relay energized) and 'Switched off' (relay de-energized).

The simulation affects the switching output.

■ Simulation open collector 1 to 3

Switch simulation of the open collector on and off.

Additional information: Selection of the switching state to be simulated: 'Switched on' (the open collector output is conducting = closed) and 'Switched off' (the open collector output is not conducting = open).

The simulation affects the switching output.

9.8.4 Simulation of digital input**Navigation**

Diagnostics → Simulation → Digital input → Digital input simulation 1 to 4

Parameters**Digital input simulation 1 to 4**

Switch digital input simulation on and off.

Additional information: Selection of the switching state to be simulated: 'Switched on' (Closed = logical state 1) and 'Switched off' (Open = logical state 0).

9.8.5 Diagnostic event simulation**Navigation**

Diagnostics → Simulation → Diagnostic event simulation

Parameters**■ Simulation**

Simulates one or more process variables and/or events.

Warning: Output will reflect the simulated value or event.

■ Diagnostic event simulation

Select the diagnostic event to be simulated.

Note: To terminate the simulation, select "Off".

■ Channel

Assign the corresponding channel to the selected diagnostic event.

9.9 Protecting settings from unauthorized access

9.9.1 Setup lock via hardware locking

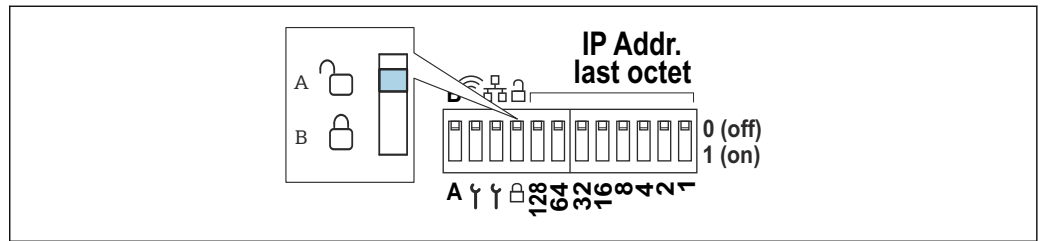

39 Hardware locking via DIP switch

A Unlocked

B Locked

The device's DIP switch includes a locking switch that can be used to prevent configuration and parameter changes. When locked, a padlock symbol  appears on the display and in the web server.

9.9.2 Securing the DIP switch to protect against tampering

The polycarbonate field housing and DIN rail device can be protected against tampering by means of a seal.

When installing in a control cabinet, the door must be secured with a lock.

10 Operation

The **Visualization** menu is designed to support the operator's tasks. It contains all the parameters that are needed in ongoing operation. Measured values and analyses can be displayed, and display settings can be configured. However, any settings made here have no effect on the measurement section or the configured device parameters.

The device's simple operating concept and the integrated help function enables you to perform operation for many applications without the need for hard-copy operating instructions.

10.1 Reading the device locking status

10.1.1 Displaying the locking status

Navigation

System → **Device management** → **Locking status**

Shows the highest write protection that is currently active.

If none of the following statuses is shown, the device is unlocked and all parameters (except service parameters) can be modified.

Locking status:**■ Hardware locked**

The device is locked by means of the DIP switch. It can only be unlocked again using this switch.

■ Upload/download active

The device is temporarily locked by internal processes (e.g. up/download or reset). Once these processes are complete, the device is automatically unlocked again.



■ Software locked

The device is locked by an external software control (e.g. fieldbus). It can only be unlocked again by this software.

10.2 Reading measured values on the touch display

10.2.1 Displaying the visualization group

 The "Operator" user rights are sufficient for this.

 How to create visualization groups is described in the "Commissioning" section.
→  52

Navigation: **Visualization** → **Group 1 to 6**

Display functions

You can switch between the configured groups by swiping left or right.

Tapping the screen in the line diagram shows all the values of the group at the time selected.

Swiping from top to bottom displays additional tools:

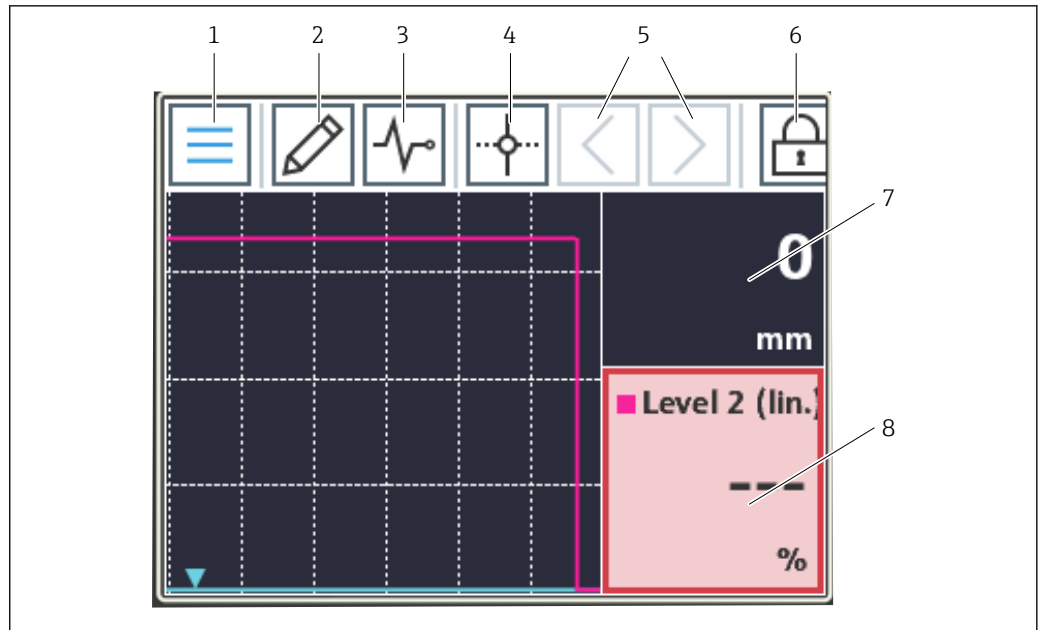

A0057074

- 1 Return to home screen
- 2 Edit group(s)
- 3 Display diagnostic list
- 4 Show/hide crosshair (cursor; vertical line)
- 5 Move crosshair in the time diagram forward/back
- 6 Activate screen lock
- 7 Show/hide individual measured value curves
- 8 Example of a channel in an invalid measurement status ("bad")

i If a measuring point enters the limit violation range, a symbol is shown at the bottom of the corresponding channel (to quickly identify limit violations). During a limit value violation and device operation, the acquisition of measured values continues uninterrupted.

If a measured value status is invalid ("bad", e.g. cable break, calculation error, device failure, etc), the corresponding tile is displayed in red.

If a measured value status is uncertain ("uncertain", e.g. HART sensor status, application-specific error etc.), the corresponding tile is displayed in yellow.





For details, see the "Diagnostics and troubleshooting" section. → 59

10.2.2 Display representation of symbols used in operation

The symbols on the device display and in the web server are generally self-explanatory. The following table only shows the symbols that need to be explained.

Symbol	Description
	Violation of lower limit value
	Violation of upper limit value or limit value on counter
	"Hold": Measured values are held, for example, during parameter configuration; in the event of an error, a fixed substitute value is maintained.

10.3 Reading measured values via the web server

-  The procedure for establishing a connection to the web server is described in the "Commissioning" section. →  42
-  If there is no activity, an auto logout is performed. The web server is not intended for continuous display of measured values.
-  The procedure for creating and displaying visualization groups via the web server is identical to that on the touch display.
-  Instructions for mobile devices:
Display errors may occur due to lack of space on small displays with multiple channels in a visualization group, combined with line and bar charts.

11 Diagnostics and troubleshooting

-  Navigation and display are identical for the local display and the web server.

11.1 General troubleshooting

Always start troubleshooting with the checklists below if faults occur after startup or during operation. The checklists take you directly (via various queries) to the cause of the problem and the appropriate remedial actions.

General faults

Fault	Possible cause	Remedial action
Device not functioning, no measured value display, no LED lit.	Supply voltage does not match the voltage specified on the nameplate.	Check and correct supply voltage.
	Connecting cables are not making contact with the terminals.	Check the contacting of the cables and terminals and correct if necessary.
	Power unit defective.	Contact the manufacturer's service department or replace the unit.
No measured value display, display is black.	Display is turned off.	Touch the display (without gloves); the display switches on. Adjust settings under System → Display → Switch off display .
	Display defective.	Access the device via the web server and check settings under System → Display . If accessible and the settings are correct: contact the manufacturer's service department or replace the device.
Display is lit, device does not respond to entries.	Operating lock is active.	Touch the display (without gloves) and trace the displayed unlock pattern with your finger. Adjust settings under System → Display → Operating lock .

Fault	Possible cause	Remedial action
Display or LED is lit, device does not respond to entries.	Software problem	Restart device by disconnecting and reconnecting the power supply.
No access to device web server.	Web server on device disabled.	Activate web server on device under System → Web server .
No WLAN connection to the device possible.	Device has no WLAN option?	Check under System → Hardware configuration → WLAN
	Incorrect settings.	Check connection settings (e.g. IP address, port, etc.) on the device System → Connectivity → WLAN and on the PC.
No Ethernet connection to the device possible.	Incorrect settings.	Check connection settings (e.g. IP address, port, etc.) on the device System → Connectivity → Ethernet and on the PC.
	Ethernet cable defective.	Replace the Ethernet cable.
Diagnostic message is displayed.	For a list of diagnostic messages, see the next section.	

11.2 Active diagnostics

Navigation: **Diagnostics** → **Active diagnostics**

Displays the following information:

- **Current diagnostics**

Displays the current diagnostic message. If several diagnostic events are pending at the same time, only the diagnostic message with the highest priority is displayed.

- **Timestamp**

Displays the timestamp for the currently active diagnostic message.

- **Last diagnostics**

Displays the diagnostic message for the last diagnostic event that has ended.

- **Timestamp**

Displays the timestamp of the diagnostic message for the last diagnostic event that has ended.

- **Operating time**

Indicates how long the device has been in operation up to this point.

- **Operating time from restart**

Indicates how long the device has been in operation since the last time the device was restarted.

- **Operating hours**

Indicates the operating hours of the display.

- **Sensor diagnostic code**

Diagnostic code of the connected HART sensor 1 or 2

11.3 Diagnostic list





Navigation: **Diagnostics** → **Diagnostic list**

Displays the following information:**Diagnostic list**

Displays the currently pending diagnostic events with max. 10 events ordered by priority (highest first). Each entry contains: Status signal as symbol, diagnostic code, description, timestamp, remedial action

 **Contact the service team** for remedial action; have the displayed **service ID** ready.

Status signals

Letter/symbol ¹⁾	Event category	Meaning
F 	Failure Failure	An operating error has occurred.
C 	Function check Function check	The device is in the service mode (e.g., during a simulation).
S 	Out of specification Out of specification	The device is being operated outside its technical specifications (e.g., during startup or cleaning processes).
M 	Maintenance required Maintenance required	Maintenance is required.
N -	Not categorized Not categorized	Only the corresponding diagnostic number is displayed

1) As per NAMUR NE 107

11.3.1 Overview of all the diagnostic messages

Diagnostic number	Short text	Remedy instructions	Status signal [from the factory]	Diagnostic behavior [from the factory]
Diagnostic of sensor				
041	Sensor 1 to 2 breakage detected	1. Check electrical connection 2. Replace sensor 3. Check configuration of connection type	F	Alarm
046	Sensor limit 1 to 2 exceeded	1. Check sensor 2. Check process conditions	F	Alarm
701	Sensor 1 to 2 PV fixed	1. Check sensor 2. Check process conditions	M	Warning ¹⁾
702	Sensor 1 to 2 PV uncertain	1. Check sensor 2. Check process conditions	M	Warning ¹⁾
703	Sensor 1 to 2 PV bad	1. Check sensor 2. Check process conditions	F	Alarm ¹⁾
710	Sensor 1 to 2 device failure	1. Check sensor 2. Replace sensor	F	Alarm ¹⁾
711	Sensor 1 to 2 check function	1. Check sensor 2. Replace sensor	M	Warning ¹⁾
712	Sensor 1 to 2 out of specification	1. Check sensor 2. Replace sensor	M	Warning ¹⁾
713	Sensor 1 to 2 maintenance required	1. Check sensor 2. Replace sensor	M	Warning ¹⁾
715	Sensor 1 to 2 malfunction	1. Check sensor 2. Replace sensor	F	Alarm ¹⁾

Diagnostic number	Short text	Remedy instructions	Status signal [from the factory]	Diagnostic behavior [from the factory]
716	Sensor 1 to 2 process value out of limits	1. Check sensor 2. Check process conditions	M	Warning ¹⁾
721	Sensor 1 to 2 echo lost	Check sensor calibration	M	Warning ¹⁾
722	Sensor 1 to 2 buildup detected	Prozessbedingungen prüfen	M	Warning ¹⁾
723	Sensor 1 to 2 foam detected	Check process conditions	M	Warning ¹⁾
724	Sensor 1 to 2 in safety distance	1. Check level 2. Check safety distance 3. Reset self holding	M	Warning ¹⁾
725	Sensor 1 to 2 mapping failed	1. Try mapping again 2. Check sensor status	S	Warning ¹⁾
726	Sensor 1 to 2 communication lost	1. Check sensor 2. Check HART address 3. Check HART resistance	F	Alarm
727	Sensor 1 to 2 multi master collision	1. Check bus for second HART master (e.g. hand held) 2. Check HART master configuration (secondary/primary)	F	Alarm
730	Sensor 1 to 2 configuration mismatch	Read configuration data from sensor or write configuration data to sensor.	F	Alarm
732	Sensor 1 to 2 wrong sensor type detected	1. Check sensor type selection 2. Connect sensor of selected sensor type	F	Alarm
740	Sensor 1 to 2 SV fixed	1. Check sensor 2. Check process conditions	M	Warning ¹⁾
741	Sensor 1 to 2 SV uncertain	1. Check sensor 2. Check process conditions	M	Warning ¹⁾
742	Sensor 1 to 2 SV bad	1. Check sensor 2. Check process conditions	F	Alarm ¹⁾
743	Sensor 1 to 2 TV fixed	1. Check sensor 2. Check process conditions	M	Warning ¹⁾
744	Sensor 1 to 2 TV uncertain	1. Check sensor 2. Check process conditions	M	Warning ¹⁾
745	Sensor 1 to 2 TV bad	1. Check sensor 2. Check process conditions	F	Alarm ¹⁾
746	Sensor 1 to 2 QV fixed	1. Check sensor 2. Check process conditions	M	Warning ¹⁾
747	Sensor 1 to 2 QV uncertain	1. Check sensor 2. Check process conditions	M	Warning ¹⁾
748	Sensor 1 to 2 QV bad	1. Check sensor 2. Check process conditions	F	Alarm ¹⁾
Diagnostic of electronic				
201	Electronics faulty	1. Restart device 2. Replace electronics	F	Alarm
230	Date/time incorrect	1. Replace RTC buffer battery 2. Set date and time	F	Alarm ¹⁾
233	Battery low	Prepare battery replacement	M	Warning
234	Battery empty	Replace battery	M	Warning

Diagnostic number	Short text	Remedy instructions	Status signal [from the factory]	Diagnostic behavior [from the factory]
252	Module incompatible	1. Check electronic module 2. Update firmware 3. Replace I/O or main electronic module	F	Alarm
275	I/O module defective	Replace I/O module	F	Alarm
331	Firmware update failed	1. Update firmware of device 2. Restart device	F	Alarm
332	Restart modules	Please wait	F	Alarm
Diagnostic of configuration				
402	Initialization active	Initialization in progress, please wait	C	Warning
411	Up-/download active	Up-/download active, please wait	C	Warning
412	Processing download	Download is being processed, please wait.	C	Warning
416	Warning occurred for HART device	1. "Hold" in progress, please wait. 2. Deactivate "Hold".	M	Warning
425	Communication certificate faulty	Replace affected certificate	M	Warning
426	Communication certificate expired	Replace affected certificate	M	Warning ¹⁾
427	Communication certificate expiring soon	Replace affected certificate	M	Warning ¹⁾
440	Device not calibrated	Calibrate device	F	Alarm
441	Current output 1 to 2 saturated	1. Check current output settings 2. Check process	M	Warning ¹⁾
485	Process variable simulation active	Deactivate simulation	C	Warning
486	Current input 1 to 2 simulation active	Deactivate simulation	C	Warning
491	Current output 1 to 2 simulation active	Deactivate simulation	C	Warning
494	Switch output 1 to 5 simulation active	Deactivate switch output simulation	C	Warning
495	Diagnostic event simulation active	Deactivate simulation	S	Warning
496	Status input 1 to 4 simulation active	Deactivate status input simulation	C	Warning
498	Open collector 1 to 3 simulation active	Deactivate simulation	C	Warning
500	Relay 1 to 5 output buffer full	1. Check process value 2. Check "pulse value"	M	Warning ¹⁾
501	Open collector 1 to 3 output buffer full	1. Check process value 2. Check "pulse value"	M	Warning ¹⁾
502	LAN/WLAN - IP address conflict	1. Check network configuration 2. Change IP address of LAN or WLAN to different subnets	M	Warning
538	Calculation configuration faulty	1. Check configuration 2. Adapt configuration	F	Alarm
550	Pump control 1 to 2 pump direction wrong	Check configuration of pump switching points	F	Alarm

Diagnostic number	Short text	Remedy instructions	Status signal [from the factory]	Diagnostic behavior [from the factory]
551	Pump control 1 to 2 pump rate not reached	1. Check device configuration 2. Check pumps 3. Check level sensors	C	Warning
552	Pump control 1 to 2 same switch-on points	Check configuration of pump switching points.	M	Warning
553	Pump 1 to 8 pump error	1. Check pump 2. Check pump feedback 3. Reset pump feedback alarm in pump control menu	F	Alarm
554	Pump control 1 to 2 storm func. on < off	Check configuration of the switching points in the "Storm function" menu.	M	Warning
555	Pump control 1 to 2 pump direction wrong	Check the configuration of the switching points in the "Automatic function test" menu.	M	Warning
556	Pump 1 to 8 max. operating hours reached	1. Check pump 2. Replace pump 3. Reset operating hours	M	Warning
557	Pump control 1 to 2 pump direction wrong	Check the configuration of the switching points in the tariff control.	M	Warning
560	Sensor 1 to 2 write configuration failed	1. Try writing parameter again 2. Unlock connected device 3. Restart connected device 4. Replace connected device	M	Warning
561	Sensor 1 to 2 read configuration failed	1. Try reading parameter again 2. Unlock connected device 3. Restart connected device 4. Replace connected device	M	Warning
570	Rake control switch point configuration	Check configuration rake control switch points.	F	Alarm
577	Sensor 1 to 2 configuration faulty	1. Check configuration 2. Adapt configuration	F	Alarm
578	Pump control 1 to 2 configuration faulty	1. Check configuration 2. Adapt configuration	F	Alarm
579	Level 1 to 2 configuration faulty	1. Check configuration 2. Adapt configuration	F	Alarm
580	Flow 1 to 2 configuration faulty	1. Konfiguration prüfen 2. Konfiguration anpassen	F	Alarm
Diagnostic of process				
879	Sensor input 1 to 2 overloaded	1. Check wiring. 2. Check sensor.	F	Alarm
950	Backwater detected	1. Check input levels 2. Check parameter "Backwater detected"	S	Warning
955	Level downstream > level upstream	1. Check rake 2. Check sensor level values	S	Warning
956	Rake control calculation error	Check level values of the sensors	F	Alarm
968	Sensor 1 to 2 level limit reached	1. Check sensor level 2. Check settings in the parameters "low/high limit" in the menu "level"	S	Warning

Diagnostic number	Short text	Remedy instructions	Status signal [from the factory]	Diagnostic behavior [from the factory]
970	Flow 1 to 2 value out of specification	1. Check process value (water level too low or too high for accurate measurement) 2. Check application 3. Check sensor	S	Warning
971	Flow 1 to 2 value above limit	1. Decrease process value 2. Check application 3. Check sensor	S	Warning
972	Level 1 to 2 value out of limits	1. Decrease process value 2. Check application 3. Check sensor	S	Warning

1) Diagnostic behavior can be changed.

11.4 Event logbook

Navigation: Diagnostics → Event logbook

Displays the following information:

Event logbook

Displays the event messages. Event messages are displayed in chronological order. The event history includes diagnostic and information events as well as all configuration changes. The symbol in front of the timestamp indicates whether the event has started or ended.

 For every configuration change, a "Direct-ID#" is shown in the event logbook (e.g. "160108-000-000"), which clearly identifies the relevant parameter. With the device-specific "Description of Device Parameters (GP)", you can use this ID to search in the PDF and clearly assign the parameter.

Structure of the "Direct-ID#":

Part 1, e.g. **160108**-000-000 = specific parameter

Part 2, e.g. 160108-**000**-000 = field index (e.g. support point)

Part 3, e.g. 160108-000-**001** = instance (e.g. channel 1, relay 1)

Important: When searching, it is sufficient to search only for the first part of the ID (e.g. "160108") in the "Description of Device Parameters (GP)".

11.5 Minimum/maximum values

Navigation: Diagnostics → Minimum/maximum values

Displays the following information:

- **Minimum/maximum electronics temperature**
Displays the lowest as well as the highest electronics temperature measured to date.
- **Reset electronics temperature min max (only possible via "Service")**
Reset minimum and maximum values for electronics temperature.
- **Level linearized**
Displays the minimum or the maximum linearized level values measured to date together with the corresponding timestamp. The values can be reset together with the associated parameter.
- **Flow**
Displays the minimum or the maximum flow measured to date together with the corresponding timestamp. The values can be reset together with the associated parameter.

-  The min./max. values are also reset in the following cases:
- The associated application is deactivated (e.g. Operating mode level1 = Off).
 - The device is reset.

11.6 Simulation

Navigation: **Diagnostics** → **Simulation**

See descriptions in the "Commissioning" section →  53.

11.7 Diagnostic settings

Navigation: **Diagnostics** → **Diagnostic settings**

NOTICE

Warning: Changes to the diagnostic settings can affect measured values, measured value status and diagnostic behavior.

- ▶ Changes to the settings are made at your own risk.

Parameter

- **Properties** → **Alarm delay**
Alarm delay: Use this function to set the delay time during which a diagnostics signal is suppressed before it is output.
- **Sensor**
Settings for the specific failure behavior and status signal.
- **Electronics**
Settings for the specific diagnostic behavior and status signal.
- **Configuration**
Settings for the specific diagnostic behavior and status signal.
- **Sensor 1, 2 (FMX21, FMU20B, FMR20B, FMR30B)**
Configuration of selected diagnostic settings for the connected HART sensor (e.g. echo, min. safety distance, etc.)

Diagnostic behavior

Navigation: Diagnostics → Diagnostic settings → Configuration → Diagnostic behavior	
Off	The diagnostic behavior is completely disabled even if the device is not recording a measured value.
Alarm	Measurement is interrupted (measured value: "bad"). The signal outputs adopt the defined alarm status. A diagnostic message is generated and displayed in the diagnostic list and in the event logbook. The failure behavior associated with the function block is applied (e.g. Application → Level → Level 1 linearized → Additional settings → Failure behavior , Extended Maintenance mode must be enabled)

Warning	The device continues to measure (measured value status: "uncertain"). A diagnostic message is generated and displayed in the diagnostic list and in the event logbook.
Logbook entry only	The device continues to measure. The event is only saved in the event logbook.

11.8 HART master

 Diagnostic information for checking the quality of the HART signal and the HART communication.

Only relevant if a HART sensor is connected.

Navigation: Diagnostics → HART master

11.9 Device reset

 Reset the device configuration - either entirely or in part - to a defined status.

Navigation: System → Device management → Device reset

11.10 Device information

 Display of important device information such as serial number, firmware version, order code, etc. for service purposes.

Navigation: System → Information

11.11 Enabling software options

Enter the application package code or the code for another subsequently ordered function to enable it.

Navigation: System → Software configuration → Software configuration → Activate SW option

 After entering a valid code, the device restarts automatically. After restarting, the newly added functionality will be enabled.

11.12 Firmware update

 To download the firmware, see the product page on the Internet at: www.endress.com

 The firmware update is only possible if a valid date is set on the device.

Firmware update is only possible via web server <ip-address/swupdate>.

The device supports Secure Boot and Secure Firmware Update, i.e. it verifies the firmware and does not allow invalid firmware updates.

The device continues to operate normally during a firmware update. A restart is only performed if the update is successful.

Navigation: System → Security → Configuration → Firmware update

 To perform the firmware update, you must log in as a maintenance technician ("Maintenance") using the appropriate PIN.

12 Maintenance

No special maintenance work is required for the device.

12.1 Cleaning

12.1.1 Cleaning of surfaces not in contact with the medium

- Recommendation: Use a lint-free cloth that is either dry or slightly dampened using water.
- Do not use any sharp objects or aggressive cleaning agents that corrode the surfaces (e.g. displays, housing) and seals.
- Do not use high-pressure steam.
- Observe the degree of protection of the device.

 The cleaning agent used must be compatible with the materials of the device configuration. Do not use cleaning agents with concentrated mineral acids, bases or organic solvents.

13 Repair

13.1 General information

The device has a modular design and repairs can be carried out by the customer's electrotechnical personnel. For more information on service and spare parts, contact the supplier.

13.1.1 Repair of Ex-certified devices

- Only specialist personnel or the manufacturer may undertake repairs on Ex-certified devices.
- The prevailing standards, national hazardous area regulations, safety instructions and certificates must be observed.
- Only use original spare parts from the manufacturer.
- When ordering spare parts, check the device designation on the nameplate. Parts may only be replaced by identical parts.
- Carry out repairs according to the instructions. On completion of the repair, carry out the routine test specified for the device.
- A certified device may only be converted to another certified device version by the manufacturer only.
- Document all repairs and modifications.

13.2 Replacing a device or electronics module

After an entire device or an electronics module has been replaced, the parameters can be downloaded to the device again via the communication interface (**Guidance → Import/Export → Load configuration**). The data must be saved on the PC beforehand using the web server (**Guidance → Import/Export → Save configuration**). You can continue to measure without performing a new calibration.

13.3 Replacing a sensor

After the sensor has been replaced, the configuration must be written back to the sensor or read from the sensor. Adjust the settings on the device under **Application** → **Sensors** → **Sensor x**.

13.4 Replacing the battery

Battery type: CR1632

 The battery may only be replaced by an electrical technician.

Installation Instructions can be downloaded from the product page on the Internet:
www.endress.com

13.5 Spare parts

Product spare parts that are currently available can be found online at:
www.endress.com/onlinetools

13.6 Return

 For return shipments in the event of service (repairs), the user account “Production” must be enabled on the device.

The requirements for safe device return can vary depending on the device type and national legislation.

1. Refer to the web page for information:
<https://www.endress.com/support/return-material>
↳ Select the region.
2. If returning the device, pack the device in such a way that it is reliably protected against impact and external influences. The original packaging offers the best protection.

13.7 Disposal

 If required by the Directive 2012/19/EU on waste electrical and electronic equipment (WEEE), the product is marked with the depicted symbol in order to minimize the disposal of WEEE as unsorted municipal waste. Do not dispose of products bearing this marking as unsorted municipal waste. Instead, return them to the manufacturer for disposal under the applicable conditions.

14 Accessories

The accessories currently available for the product can be selected at www.endress.com:

1. Select the product using the filters and search field.
2. Open the product page.
3. Select **Spare parts & Accessories**.

14.1 Device-specific accessories

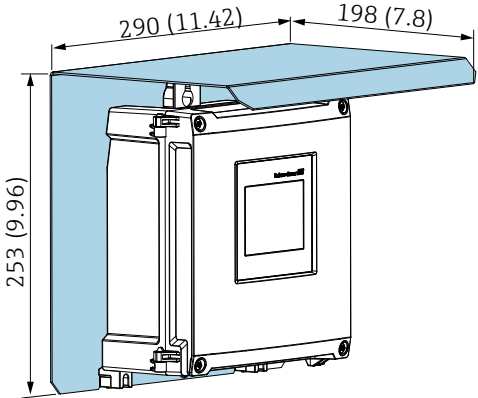
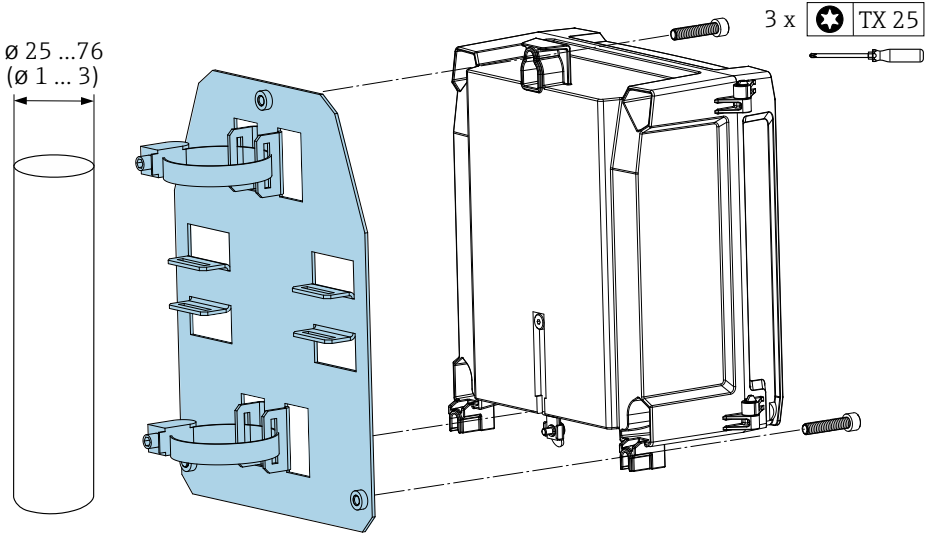
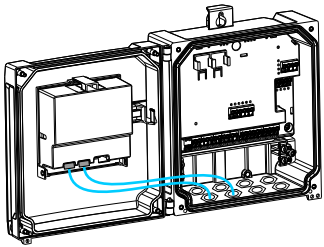
Type	
Stainless steel 316Ti (1.4571) weather protection cover for polycarbonate field housing	
	
A0053172 40 Weather protection cover for direct wall mounting or using assembly board for pipe mounting. Unit of measurement mm (in)	
Assembly board for pipe mounting for polycarbonate field housing	
	
A0053940 41 Mounting plate for pipe mounting of polycarbonate field housing. Unit of measurement mm (in)	
<ul style="list-style-type: none"> ▪ Pipe diameter: 25 to 76 mm (1 to 3 in) ▪ Dimensions: 210 x 110 mm (8.27 x 4.33 in) ▪ Material: Stainless steel 316L ▪ Mounting accessories: Fastening clips, screws and nuts are supplied. 	
Cable glands 4x M16x1.5/2x M20x1.5/2x M25x1.5	
	Cable with M12 to RJ45 connector, 345 mm (13.58 in)
A0056168	

14.2 Service-specific accessories

14.2.1 Software

Netilion

With the Netilion IIoT ecosystem, Endress+Hauser enables the optimization of plant performance, digitization of workflows, sharing of knowledge and improved collaboration. Drawing upon decades of experience in process automation, Endress+Hauser offers the process industry an IIoT ecosystem designed to effortlessly extract insights from data. These insights allow process optimization, leading to increased plant availability, efficiency, reliability and ultimately a more profitable plant.



www.netilion.endress.com

Field Xpert SMT50

Universal, high-performance tablet PC for device configuration.



www.endress.com/smt50

14.3 Online tools

Product information about the entire life cycle of the device is available at:
www.endress.com/onlinetools

14.4 System components

Surge arrester modules from the HAW product family

Surge arrester modules for DIN rail and field device mounting, for the protection of plants and measuring instruments with power supply and signal/communication lines.

More detailed information: www.endress.com

15 Technical data

15.1 Input

15.1.1 Measured variable and measuring range of the sensor inputs

Number of sensor inputs

To be selected in order code 060 (sensor connection; analog output)

1x 4–20 mA/HART input; 1x 4–20 mA output

2x 4–20 mA/HART input; 2x 4–20 mA output

Connectable sensors

1. Connectable Endress+Hauser sensors with automatic sensor detection:

- Micropilot FMR20B, FMR30B
- Prosonic FMU20B, FMU30B
- Waterpilot FMX21

 The most important sensor parameters are transmitted to the device via the HART interface and managed there. This makes it possible, for example, to replace the sensor quickly and easily.

2. Connectable Endress+Hauser 4 to 20 mA sensors:

- Micropilot FMR10B
- Waterpilot FMX11

3. Universal level sensors can also be connected to the 4 to 20 mA/HART inputs.

Sensor supply

Supply voltage (LPS): 14 to 27 V (load-dependent)

Input resistor current measurement: 25 Ω typ.

Internal HART communication resistor: 330 Ω typ.

Measurement accuracy

Basic accuracy: < 0.02 mA

Temperature drift: < 2 μA/K

Long-term drift: < 0.02 mA/year

15.1.2 Digital inputs

Number of digital inputs

4; to be selected in order code 080 (digital input; switch output)

Switching possibilities

External level switch (for safety functions such as overflow or dry-running protection)

- 0: ≤ 5 V
- 1: ≥ 11 V
- Maximum permitted voltage: 30 V

Possible applications

- Pump feedback
- Min/max level detection e.g. using Liquiphant

15.2 Output

15.2.1 Analog output (current output)

Quantity

To be selected in order code 060 (sensor connection; analog output)

1x 4–20 mA/HART input; 1x 4–20 mA output

2x 4–20 mA/HART input; 2x 4–20 mA output

Technical data for analog output

- Version: active current output
- Load: Max. 600 Ω
- Basic accuracy: < 0.02 mA
- Temperature drift: < 2 $\mu\text{A/K}$
- Long-term drift: < 0.02 mA/year

Output signal

Configurable:

- 4 to 20 mA with HART (optional)
- 0 to 20 mA without HART

 Optional: The HART signal is superimposed on the first analog output.

The second analog output does not have a HART signal.

Response to errors

- For setting 4 to 20 mA, selectable:
 - MIN: 3.5 mA
 - MAX: Adjustable 21.5 to 22.5 mA
- For setting 0 to 20 mA:
 - Adjustable 21.5 to 22.5 mA

15.2.2 Relay output**Quantity**

To be selected in order code 070 (relay output)

Selection 1 relay: Version as SPDT ²⁾

Selection 5 relay: 2xSPDT ²⁾, 3xSPST ³⁾;

Technical data for relay

- Version: Potential-free contact, can be inverted
- Switching capacity (DC voltage): 4 A at 30 V
- Switching capacity (AC voltage): 4 A, 250 V, 1 000 VA (AC1)
- Mechanical switching cycles (without load): > 10⁶
- Mechanical switching cycles (under load): > 10⁴

Assignable functions

 The functions that can be assigned to a switch output or a relay are identical.

- Alarm:
 - Switches as soon as "Alarm" type diagnostics are pending
- Switch output:
 - Digital inputs
 - Limit values
- Pump control application:
 - Pumps
 - Flush control
 - Alarm feedback
 - Alarm operating hours
- Rake control application:
 - Switching the rake

2) "Single Pole, Double Throw" = relay with changeover contact

3) "Single Pole, Single Throw" = relay with normally-open contact

- Flow measurement application:
 - Backwater alarm
- Pulse output:
 - Flow 1 or 2
 - Calculated flows
- Time pulse output:
 - Switching a pulse after an adjustable duration

15.2.3 Switch output

Quantity

To be selected in order code 080 (digital inputs; switch outputs)

1 or 3 open collector outputs (NPN)

Technical data for switch output

- Max. switching current: 120 mA
- Max. voltage: 30 V
- Max. rate: 1000 pulses/second (at a load resistance $\leq 10 \text{ k}\Omega$); adjustable pulse length
- Voltage drop when switched on (live): $< 3 \text{ V}$

Assignable functions



The functions that can be assigned to a switch output or a relay are identical.

- Alarm:
 - Switches as soon as "Alarm" type diagnostics are pending
- Switch output:
 - Digital inputs
 - Limit values
- Pump control application:
 - Pumps
 - Flush control
 - Alarm feedback
 - Alarm operating hours
- Rake control application:
 - Switching the rake
- Flow measurement application:
 - Backwater alarm
- Pulse output:
 - Flow 1 or 2
 - Calculated flows
- Time pulse output:
 - Switching a pulse after an adjustable duration

15.2.4 Galvanic isolation

The following connections are galvanically isolated from one another:

- Power supply
- Sensor inputs
- Analog outputs
- Relay outputs
- Digital inputs (isolated from other connections but not from each other)
- Open collector outputs

15.3 Power supply

15.3.1 Connection data (AC voltage)

Device version

Order code 020 (power supply); option 1 (100-230 V AC)

- Supply voltage: 85 to 253 V_{AC} (50/60 Hz)
- Power consumption: Max. 20 VA

15.3.2 Connection data (DC voltage)

Device version

Order code 020 (power supply); option 2 (10.5-32 V DC)

- Supply voltage: 10.5 to 32 V_{DC}
- Power consumption: Max. 15 VA

CAUTION



- ▶ The device must be powered only by a power unit that operates using a limited-energy circuit in accordance with UL/EN/IEC 61010-1, Section 9.4 and the requirements in Table 18.
- ▶ Apart from the relays and the AC supply voltage, only energy-limited circuits according to IEC/EN 61010-1 may be connected.

15.3.3 Terminal assignment

Terminal areas of DIN rail device

Device version

Order code 040 (housing); option A (DIN rail mounting)

-  The DIN rail device is designed for installation in the optional aluminum field housing.
-  The DIN rail device is available with or without a display unit (optional). The electrical connection is the same.

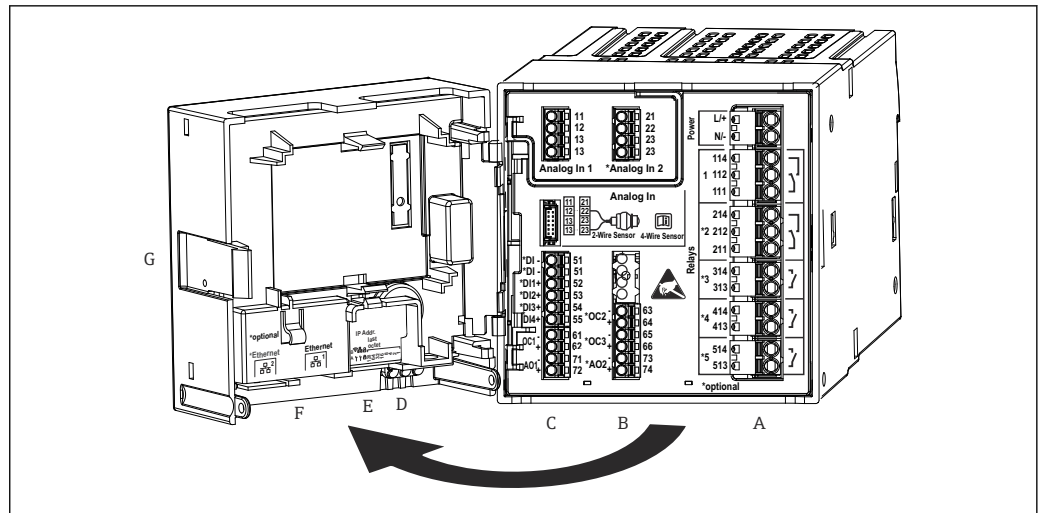

A0049209

42 Terminals for DIN rail device; terminal design: attachable push-in terminals

- A Power unit with relay 1 (changeover contact). Optional: Relay 2 to 5
- B I/O option card with analog input 2 (incl. loop power supply), analog output 2, open collector 2, 3
- C Standard I/O card with analog input 1 (incl. loop power supply), analog output 1, open collector 1, optional: digital inputs 1 to 4
- D 3 LEDs (only for version without display): DS (device status), NS (network status), WLAN
- E DIP switch
- F Ethernet connection 1 (standard), Ethernet connection 2 (optional)
- G Unlocking device

i The switching positions of the relays shown on the terminal area refer to the de-energized (current-free) state.

Terminal areas of panel-mounted device

Device version

Order code 040 (housing); option B (panel mounting)

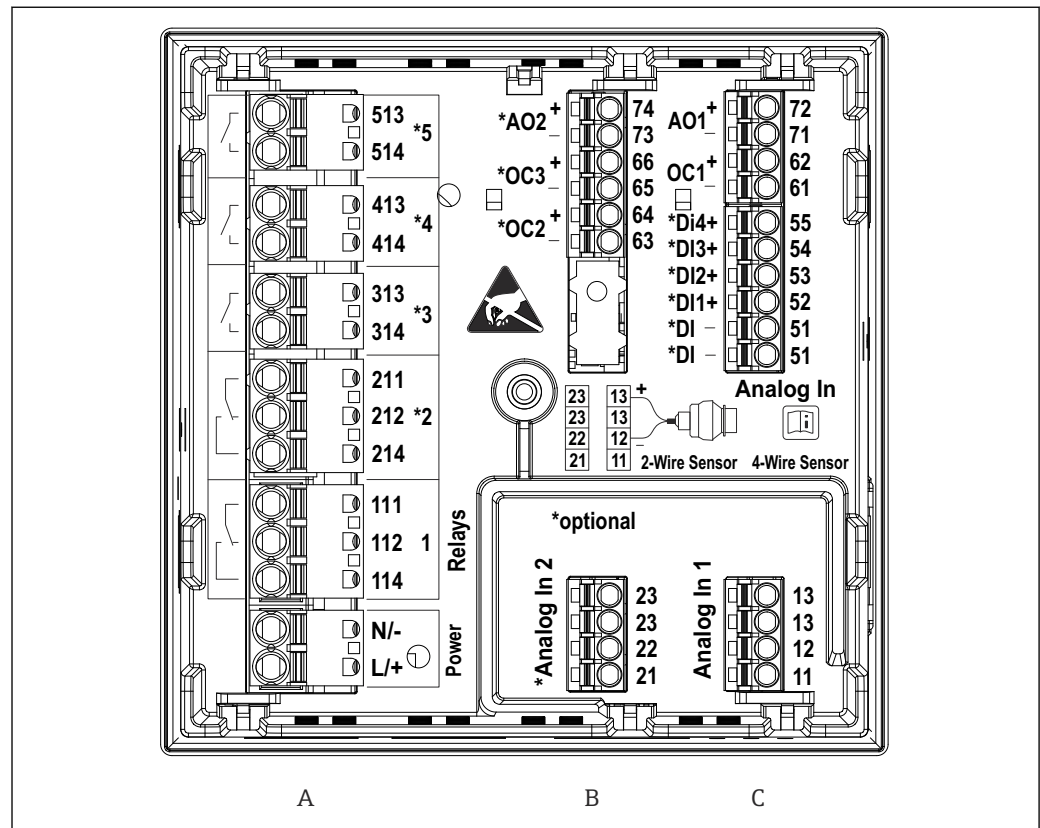

43 Terminals for panel-mounted device (rear of device); terminal design: attachable push-in terminals

- A Power unit with relay 1 (changeover contact). Optional: Relay 2 to 5
- B I/O option card with analog input 2 (incl. loop power supply), analog output 2, open collector 2, 3
- C Standard I/O card with analog input 1 (incl. loop power supply), analog output 1, open collector 1, optional: digital inputs 1 to 4

i The switching positions of the relays shown on the terminal area refer to the de-energized (current-free) state.

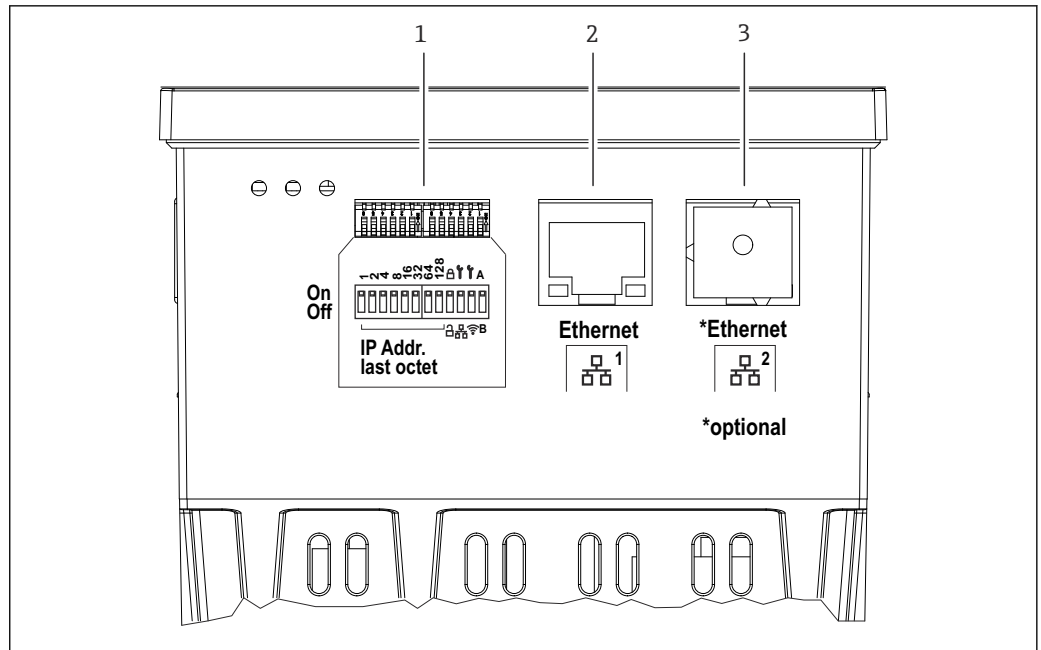

A0053119

44 Connections for panel-mounted device (underside of devices)

- 1 DIP switch
- 2 Ethernet connection 1 (standard)
- 3 Ethernet connection 2 (optional)

Terminal areas of polycarbonate field housing

Device version

Order code 040 (housing); option C (field mounting, polycarbonate)

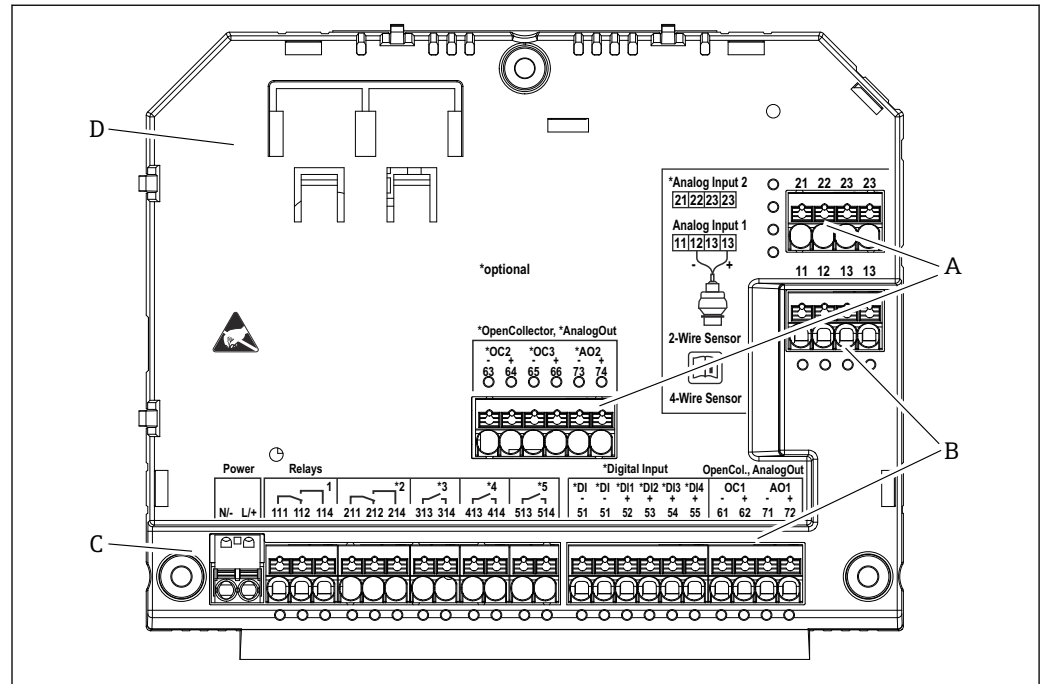

45 Terminals in terminal compartment of polycarbonate field housing; terminal design: push-in terminals

- A Terminal area for analog input 2 (incl. loop power supply), analog output 2, open collector 2, 3
- B Terminal area for analog input 1 (incl. loop power supply), analog output 1, open collector 1, optional: Digital inputs 1 to 4
- C Terminal area for power supply and relay 1 (changeover contact). Optional: Relay 2 to 5
- D Holder for commercially available shunting clamps

i The switching positions of the relays shown on the terminal area refer to the de-energized (current-free) state.

Terminal areas on rear side of display for the polycarbonate field housing

Device version

Order code 040 (housing); option C (field mounting, polycarbonate)

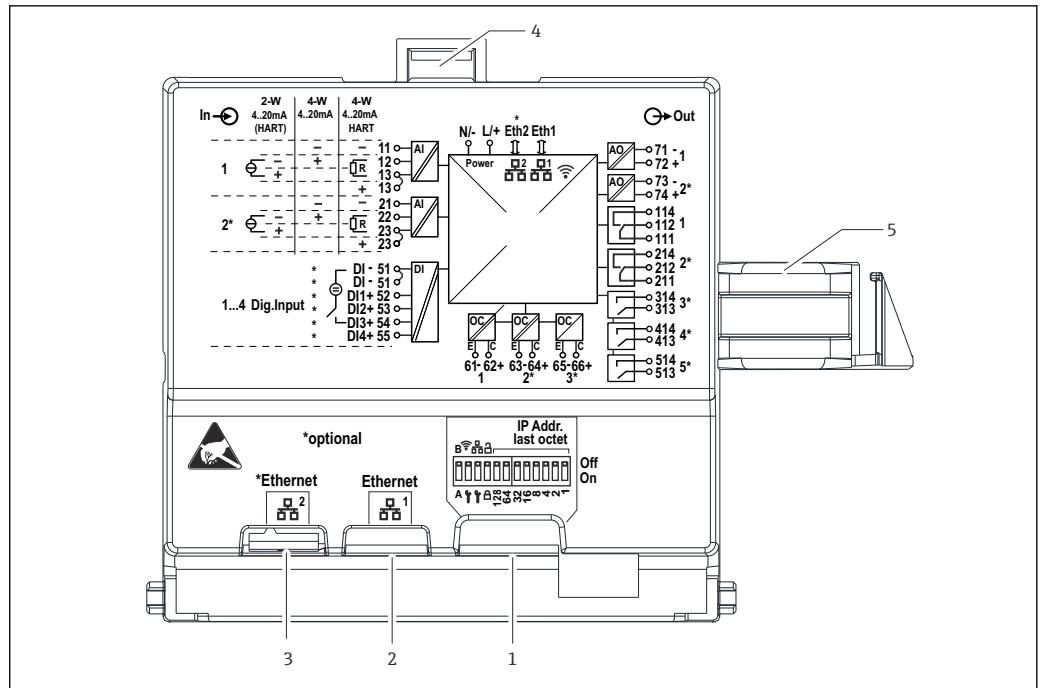

46 Connections on the rear side of display for the polycarbonate field housing

- 1 DIP switch
- 2 Ethernet connection 1 (standard)
- 3 Ethernet connection 2 (optional)
- 4 Locking device
- 5 Connecting cable to the main board

i Adapters for RJ45 to M12 connectors are available as an option for the field housing (see "Accessories" section in Operating Instructions). The adapters connect the RJ45 Ethernet interfaces with the M12 connectors mounted in the cable entries. Therefore the connection to the Ethernet interface can be established via an M12 connector without opening the device.

15.3.4 Terminals

The device is fitted with push-in terminals. Rigid conductors or flexible conductors with ferrules can be inserted directly into the terminal without using the lever, and create a contact automatically.

15.3.5 Cable entries

Cable entries of polycarbonate field housing

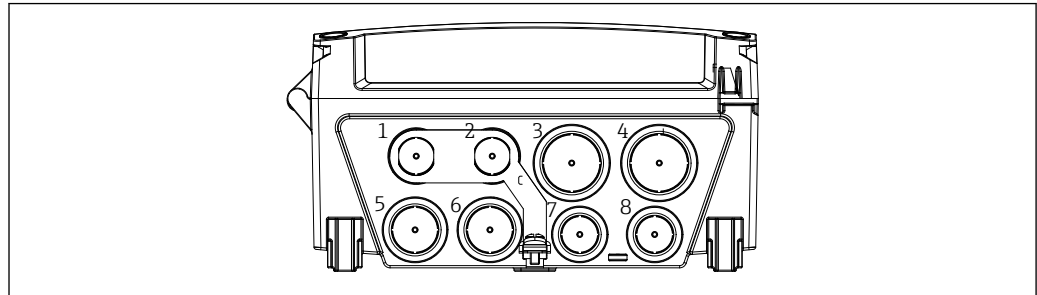

A0061447

47 Precut openings on the bottom of the housing for the following cable entries (example):

- 1 M16x1.5 for Ethernet 2 when using M12 connection or digital I/O
- 2 M16x1.5 for Ethernet 1 when using M12 connection or digital I/O
- 3 M25x1.5 for Ethernet 2 when using a patch cable, digital I/O, or analog I/O
- 4 M25x1.5 for Ethernet 1 when using a patch cable, digital I/O, or analog I/O
- 5 M20x1.5 for power supply
- 6 M20x1.5 for digital I/O
- 7 M16x1.5 for analog I/O
- 8 M16x1.5 for analog I/O

Use a suitable tool to cut out the required openings.

Cable entries for aluminum field housing

- There are eight M20x1.5 openings with dummy covers for cable entries on the bottom of the field housing.
- For the electrical connection, remove the dummy covers and replace them with cable glands. Guide the cables through the cable glands and into the housing. The device is then connected in the same way as the DIN rail device.
- Ethernet cable connection: Insert the cable without the plug and then mount the plug inside.

15.3.6 Cable specification

CAUTION

Unsuitable connection cables may cause overheating and fire hazards, insulation damage, electric shock, power loss, and reduced operating life.

- ▶ Only use connection cables that comply with the specifications below.

i Minimum requirement: Cable temperature range \geq ambient temperature +20 K

For all connections on the field device and for power and relay connections in the case of the panel-mounted and DIN rail device:

- **Conductor cross-section:** 0.2 to 2.5 mm² (26 to 14 AWG)
- **Cross-section with wire end ferrule:** 0.25 to 2.5 mm² (24 to 14 AWG)
- **Stripping length:** 10 mm (0.39 in)

For digital input, open collector and analog input/output connections in the case of panel-mounted and DIN rail device:

- **Conductor cross-section:** 0.2 to 1.5 mm² (26 to 16 AWG)
- **Cross-section with wire end ferrule (excluding collar/including collar):**
0.25 to 1 mm² (24 to 16 AWG) / 0.25 to 0.75 mm² (24 to 16 AWG)
- **Stripping length:** 10 mm (0.39 in)

15.4 Performance characteristics

-  Only the performance characteristics of the device are mentioned at this point.
Sensor-specific performance characteristics: See the technical data for the relevant sensor.

15.4.1 Reference operating conditions

- Temperature: +25 °C (+77 °F) ±5 °C (±9 °F)
- Pressure: 960 mbar (14 psi) ±100 mbar (±1.45 psi)
- Humidity: 20 to 60 % r.F.

15.4.2 Maximum measurement error

See the "Sensor inputs" and "Analog output" sections

15.4.3 Response time

The response time is defined from a physical input up to the response at a physical output.

- Response time without HART: < 500 ms
- Response time with HART: < 2 s
- Response time for open circuit: < 5 s

15.4.4 Real-time clock (RTC)

- Automatic or manual summer time changeover.
- Battery buffer. Operating life > 5 years if the device is not supplied with energy, > 10 years if the device is supplied with energy.
- Drift: < 15 min./year
- Time synchronization possible via NTP.

15.5 Mounting

-  Ensure compliance with the permitted ambient conditions during installation and operation. The device must be protected against the effects of heat (see the "Environment" section).

15.5.1 Mounting location

Panel mounting, installation on a DIN rail or installation in the field housing possible. The mounting location must be free from vibrations. A suitable electrical, fire-proof and mechanical enclosure must be provided.

Panel mounting and DIN rail version:

- In the control cabinet outside potentially explosive atmospheres
- At a sufficient distance from high-voltage cables or motor cables as well as contactors or frequency converters
- Minimum distance to the left: Panel-mounted device: 10 mm (0.4 in); DIN rail device: 20 mm (0.8 in)

Field housing:

- Protected from direct sunlight. Use a weather protection cover if necessary (see "Accessories")
- If mounting outdoors: Use overvoltage protection (see "Accessories")
- Minimum clearance to the left: 55 mm (2.17 in); the housing cover cannot be opened otherwise.

15.5.2 Orientation

Vertical

15.5.3 Installation instructions

Special mounting instructions

An optional assembly board is available to mount the field housing, see "Accessories".

Sensor selection and arrangement

 Please note the respective Operating Instructions when it comes to installing and mounting the sensor.

15.5.4 Length of connecting cable

See technical data of the respective sensor.

15.5.5 Connecting cable

See technical data of the respective sensor.

15.5.6 Beam angle

See technical data of the respective sensor.

15.6 Environment

15.6.1 Ambient temperature range

-40 to +60 °C (-40 to +140 °F) (Type tested)

-35 to +60 °C (-31 to +140 °F) (approved by CSA)

- The functionality of the LCD display becomes limited at $T_A < -20\text{ °C}$ (-4 °F).
- If operating outdoors in strong sunlight: Use a weather protection cover.

15.6.2 Storage temperature

-40 to +80 °C (-40 to +176 °F)

15.6.3 Relative humidity

Maximum 95%

Non-condensing in the case of panel-mounted and DIN rail device.

15.6.4 Operating height

Non-ex version:

Maximum 3 000 m (9 842 ft) above standard elevation zero

Ex version:

Maximum 2 000 m (6 562 ft) above standard elevation zero

15.6.5 Degree of protection

Degree of protection of polycarbonate field housing

IP65/NEMA Type 4x

Degree of protection of aluminum field housing

IP65/NEMA Type 4x

Degree of protection of DIN rail housing

IP20

Degree of protection of panel housing

- IP65/NEMA Type 4 (at front, if mounted in cabinet door)
- IP20 (at rear, if mounted in cabinet door)

15.6.6 Electrical safety

- Electrical safety according to IEC 61010-1:2010/AMD1:2016/COR1:2019
- Class:
 - 230 V_{AC} version: Class II equipment
 - 24 V_{DC} version: Class III equipment
- Overvoltage category II
- Pollution level 2
- Upstream overcurrent protection device ≤ 10 A

15.6.7 Mechanical load

Vibration resistance

Field housing: Sinusoidal vibrations according to IEC 60068-2-6

* 2 to 8.4 Hz with 3.5 mm (0.14 in) amplitude (peak)

* 8.4 to 500 Hz with 1g acceleration (peak)

For all housing variants: Noise-induced vibrations according to IEC 60068-2-64

* 10 to 200 Hz with 0.003 g²/Hz

* 200 to 2 000 Hz with 0.001 g²/Hz

Shock resistance

Field housing: Half-sine vibrations according to IEC 60068-2-27 (30G, 6 ms)

Note: Deviations from normal operation may occur during the test (e.g. switching of relays).

Impact resistance

Impact resistance and drop test according to IEC 61010-1:2010/AMD1:2016-/COR1:2019

15.6.8 Cleaning

A clean, dry cloth can be used to clean the device.

15.6.9 Electromagnetic compatibility (EMC)

Electromagnetic compatibility in accordance with all the relevant requirements outlined in the EN 61326 series and NAMUR Recommendation EMC (NE 21). For details, refer to the Declaration of Conformity.

Under the influence of interference, the measurement error may be 1% of the full scale value (0.5% for sensor inputs in 4 to 20 mA operation).

Interference immunity according to IEC/EN 61326 series, industrial requirements.

With regard to interference emission, the device meets the requirements of Class A, and is only designed for use in an "industrial environment".

Interference emission according to IEC/EN 61326 series (CISPR 11) Group 1 Class A

i This device is not intended for use in living areas. Appropriate protection of the radio reception cannot be ensured in such environments.

15.7 Mechanical construction

15.7.1 Dimensions

Polycarbonate field housing

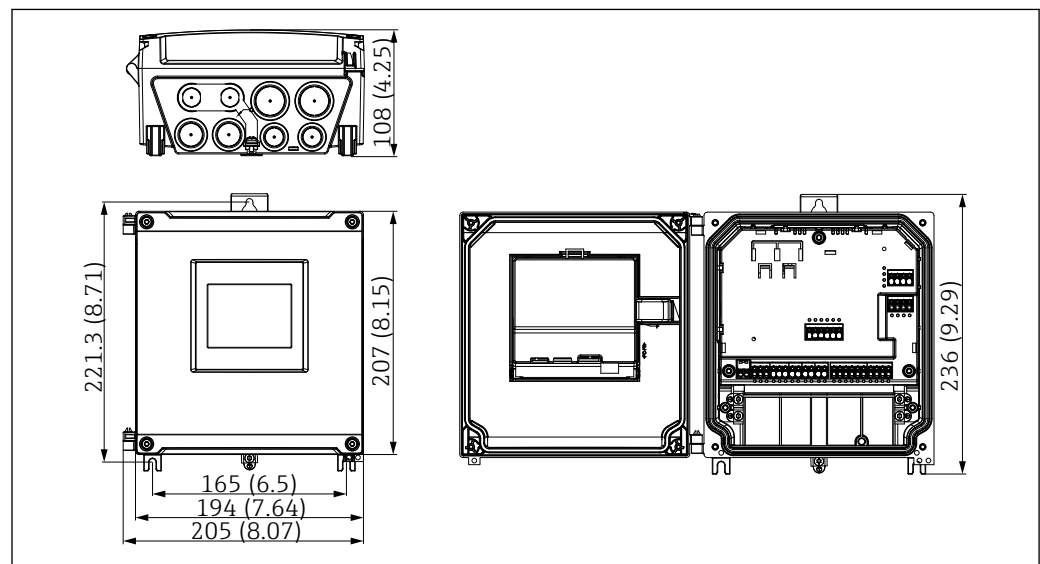

48 Polycarbonate field housing. Unit of measurement mm (in)

Aluminum field housing

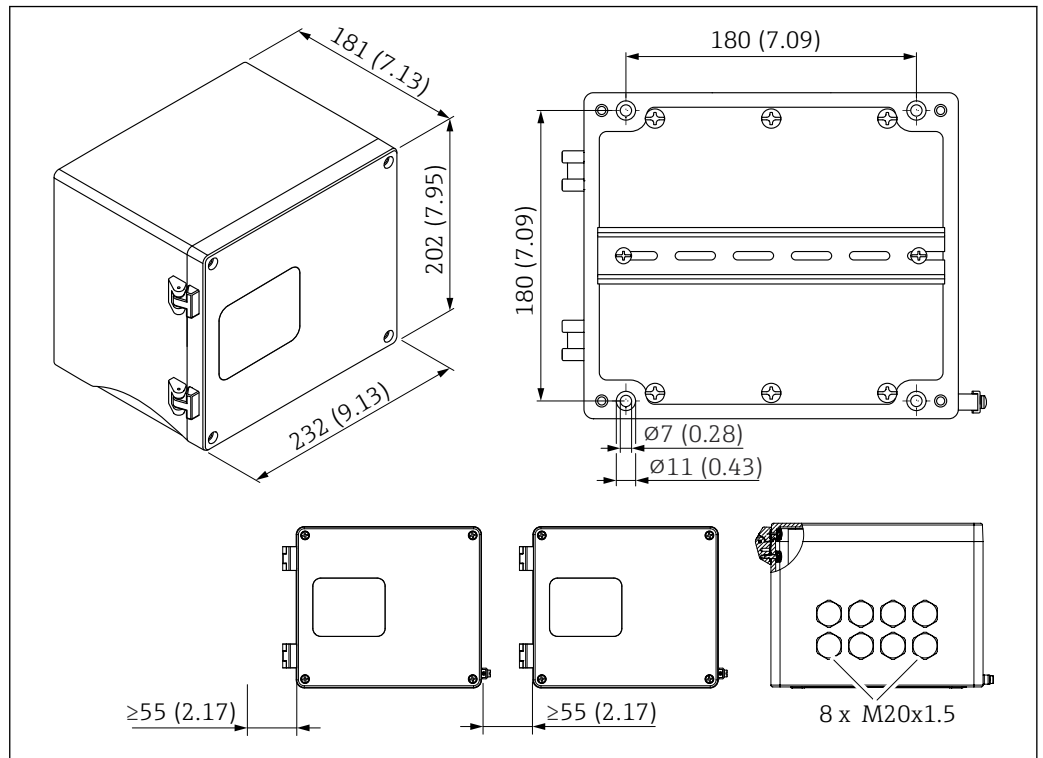

49 Aluminum field housing (for installing the DIN rail device). The cable entries are located on the bottom. Unit of measurement mm (in)

DIN rail device

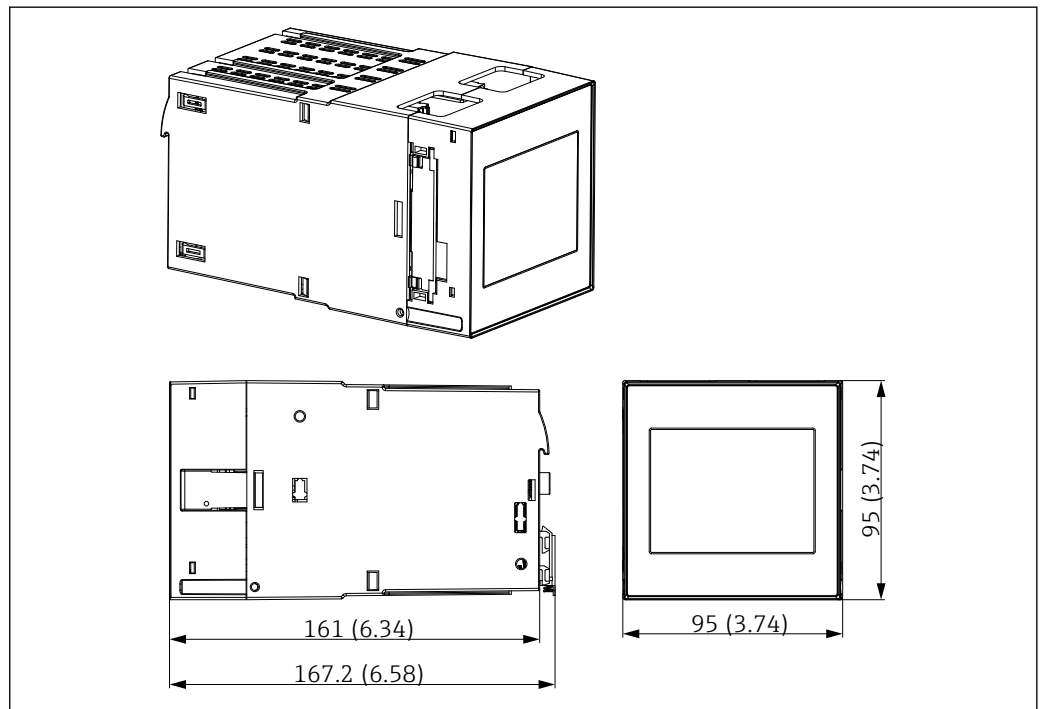

50 DIN rail housing. Unit of measurement mm (in)

Panel-mounted device

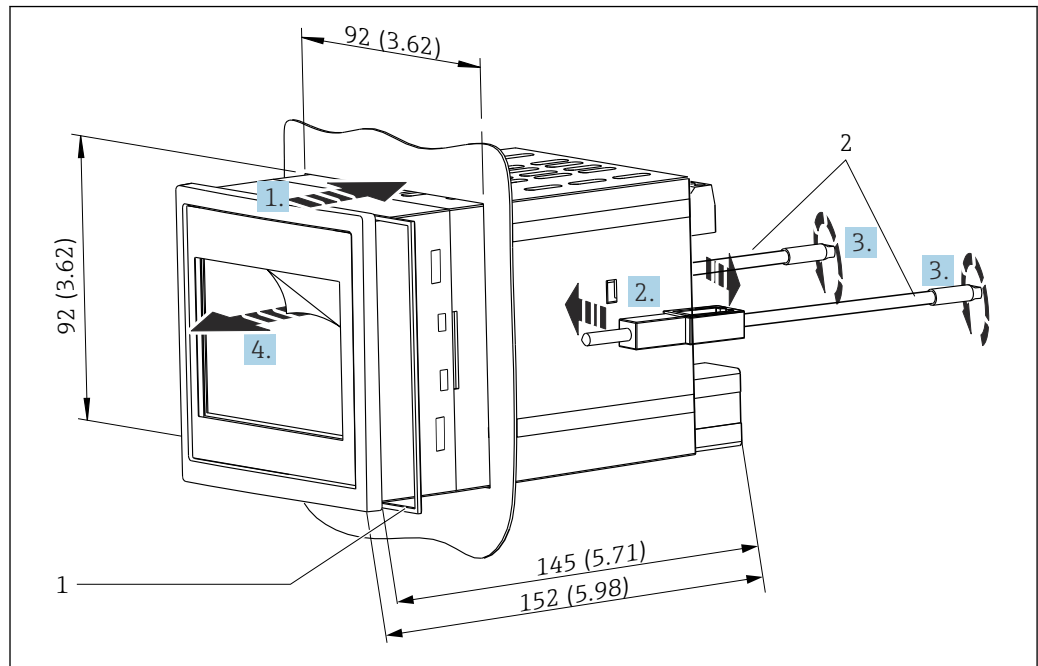

51 Panel housing (panel cutout 92 mm (3.62 in) x 92 mm (3.62 in)). Unit of measurement mm (in)

- 1 Sealing ring (included in the delivery)
- 2 Fastening clips (2x included in the delivery)

15.7.2 Weight

Polycarbonate field housing

Approx. 1.6 to 1.8 kg (3.53 to 3.97 lb) depending on device version

Aluminum field housing

Approx. 1.6 to 1.8 kg (3.53 to 3.97 lb) depending on device version

DIN rail device

Approx. 0.7 kg (1.54 lb) depending on device version

Panel-mounted device

Approx. 0.5 kg (1.10 lb)

15.7.3 Materials

Polycarbonate field housing

- Assembly board for pipe mounting: Stainless steel 316L
- Field housing: PC-FR
- Seal: VMQ
- Nameplate: Polyester
- Screws: A4 (1.4578)

Aluminum field housing

- Field housing: Aluminum
- Seal: PUR soft foam
- Nameplate: Polyester
- Screws: A4 (1.4578)

Panel-mounted and DIN rail device

- Housing: PC
- Seal for panel housing: EPDM
- Nameplate: Lasered on

15.8 Operability

The device's display and operating options are defined in order code 050 (display, operation)

- 1: None; RJ45 Ethernet
- 2: None; RJ45 Ethernet + WLAN
- 3: 3.5" TFT touch display; RJ45 Ethernet
- 4: 3.5" TFT touch display; RJ45 Ethernet + WLAN

15.8.1 Onsite operation and display

The device is optionally equipped with a 3.5" TFT touch display for onsite operation.

Size (diagonal screen measurement)

90 mm (3.5 ")

Resolution

QVGA, 76,800 pixels (320 x 240)

Backlight

50,000 h half-life (= half brightness)

Number of colors

24 bit color depth; 16.7 million displayable colors

Maximum character size; number of digits

Digit height max. 50 pixels or 13 mm with max. seven digits

Viewing angle

Max. viewing angle range: 85° in all directions from the display central axis

Screen displays

- Users can choose between black and white for the background color.
- Active channels can be assigned to up to six groups. For unique identification, each group can be given a descriptive name.
- Linear scaling
- Horizontal curve display, bar graph display or digital display

15.8.2 Operation concept

The device can be operated directly on site (option of 3.5" TFT touch display), or through remote configuration via interfaces and operating tools (web server).

Integrated Operating Instructions

Thanks to the device's simple operating concept, it is possible to commission the device for many applications without a hard copy of the Operating Instructions. The device has an integrated help function and displays operating instructions directly on the monitor.

Dynamic operating menu

Only function groups that are relevant for the device version and installation environment are displayed in the menu. The integrated wizard guides the user intuitively through the entire commissioning process.

Locking operation

- Via the lock switch in the terminal compartment
- Via touch display on the operating module
- Automatic operating lock after a set time (configurable)

15.8.3 Languages

The following languages can be selected in order code 500 (operating language display):

English, German, French, Spanish, Italian, Dutch, Portuguese, Polish, Russian, Turkish, Chinese (simplified), Japanese, Korean, Indonesian, Czech, Swedish

15.8.4 Remote operation

The device can be operated independently of the optional touch display using the following operating tools:

Operation options

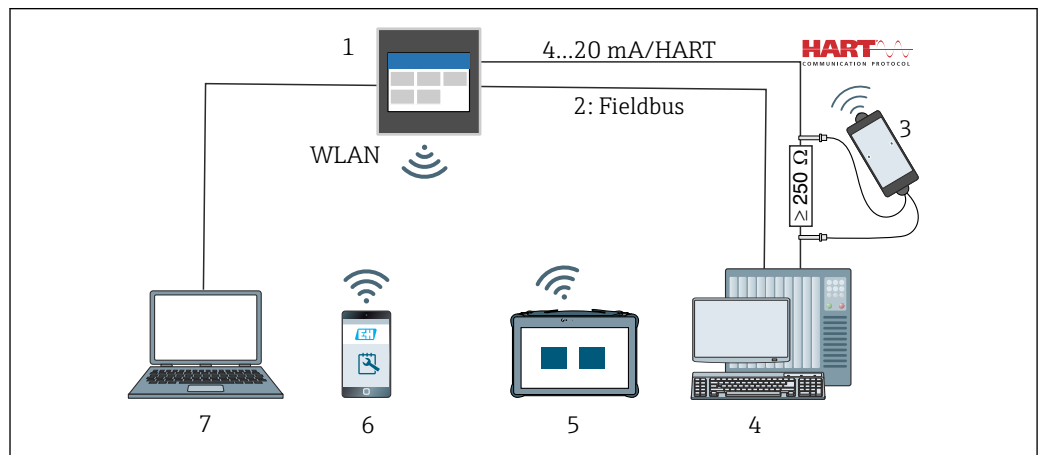

52 System integration

- 1 FlexView FMA90
- 2 Fieldbus: communication via Ethernet fieldbus to PLC (optional)
- 3 Optional: HART modem with connecting cable, e.g. Commubox FXA195 or VIATOR Bluetooth (restricted operation)
- 4 Optional: PLC via HART protocol (FDI package, restricted operation)
- 5 Field Xpert SMT70 via WLAN and web server
- 6 Operation and configuration via WLAN and web server
- 7 Operation and configuration via Ethernet and web server

Device access via WLAN

The device is optionally equipped with WLAN. In addition to Ethernet TCP/IP, device access is therefore also possible via WLAN.

Operation options via web server

A web server is integrated into the device. The web server offers the following functionality:

- Easy configuration without additional installed software
- Instantaneous value display and diagnostics information
- Display of current measured value curves
- Display of events and logbook entries
- Device firmware update
- Device configuration indicated as PDF

15.8.5 System integration

Communication	Driver technology	Configuration possible	Systems (examples)
HART	EDD	No	EDD hosts (e.g. Emerson AMS, Yokogawa PRM)
HART	EDD (Siemens)	No	Siemens PDM
Modbus TCP		No	Control systems, e.g. Siemens, Emerson

 HART slave communication and Modbus TCP server communication are order options. For further details on system connection, see the associated Operating Instructions.

15.8.6 Supported operating tools

Device configuration and measured value retrieval can also be done via interfaces. The following operating tools are available for this purpose:

Operating tool	Functions	Communication
Web server (integrated into the device; access via browser)	<ul style="list-style-type: none"> ▪ Easy configuration without additional installed software ▪ Display of data and measured value curves via the web browser ▪ Remote access to device and diagnostic information 	Ethernet, WLAN

15.9 Certificates and approvals

Current certificates and approvals for the product are available at www.endress.com on the relevant product page:

1. Select the product using the filters and search field.
2. Open the product page.
3. Select **Downloads**.

15.10 Ordering information

Detailed ordering information is available from your nearest sales organization www.addresses.endress.com or in the Product Configurator at www.endress.com:

1. Select the product using the filters and search field.
2. Open the product page.

3. Select **Configuration**.

15.10.1 Scope of delivery

The scope of delivery of the device comprises:

- Device (with terminals, according to order)
- Panel-mounted device: Two screw fastening clips, sealing rubber towards the panel wall
- Delivery note
- Hard copy of Brief Operating Instructions
- Hard copy of Ex Safety Instructions (optional)

15.11 Supplementary documentation

The following document types are available in the Downloads area of the Endress+Hauser website (www.endress.com/downloads):

Document type	Purpose and content of the document
Technical Information (TI)	Planning aid for your device The document contains all the technical data on the device and provides an overview of the accessories and other products that can be ordered for the device.
Brief Operating Instructions (KA)	Guide that takes you quickly to the 1st measured value The Brief Operating Instructions contain all the essential information from incoming acceptance to initial commissioning.
Operating Instructions (BA)	Your reference document These Operating Instructions contain all the information that is required in the various life cycle phases of the device: from product identification, incoming acceptance and storage, to mounting, connection, operation and commissioning, through to troubleshooting, maintenance and disposal.
Description of Device Parameters (GP)	Reference for your parameters The document provides a detailed explanation of each individual parameter. The description is aimed at those who work with the device over the entire life cycle and perform specific configurations.
Safety Instructions (XA)	Depending on the approval, safety instructions for electrical equipment in hazardous areas are also supplied with the device. These are an integral part of the Operating Instructions.  Information on the Safety Instructions (XA) that are relevant for the device is provided on the nameplate.
Supplementary device-dependent documentation (SD/FY)	Always comply strictly with the instructions in the relevant supplementary documentation. The supplementary documentation is an integral part of the device documentation.



www.addresses.endress.com
