

# Installation Instructions

## **CCV05 kit**

For CCS5x sensors (D/E)



## Table of contents

1	Overview .....	3
2	Intended use .....	4
3	Authorized installation personnel .....	4
4	Safety instructions .....	5
5	Scope of delivery .....	6
6	Cleaning the sensor .....	6
7	Replacing the membrane cap .....	8
8	Electrolyte replacement (CCV05-5xB maintenance kits) .....	10
9	Replacing the seals (CCV05-5xC seal set) .....	11
10	Additional documentation .....	13
11	Disposal .....	13

# 1 Overview

## 1.1 Product structure

		<b>Sensor / parameter</b>	
	50	CCS50, CCS50D, CCS50E / chlorine dioxide	
	51	CCS51, CCS51D, CCS51E / free chlorine	
	53	CCS53E / total chlorine	
	55	CCS55D, CCS55E / free bromine	
		<b>Maintenance station</b>	
		A	2x membrane cap + 1x electrolyte 50 ml
		B	1x electrolyte 50 ml
		C	2 x sealing set
CCV05-	xx	xx	Complete order code

## 1.2 Sensor overview

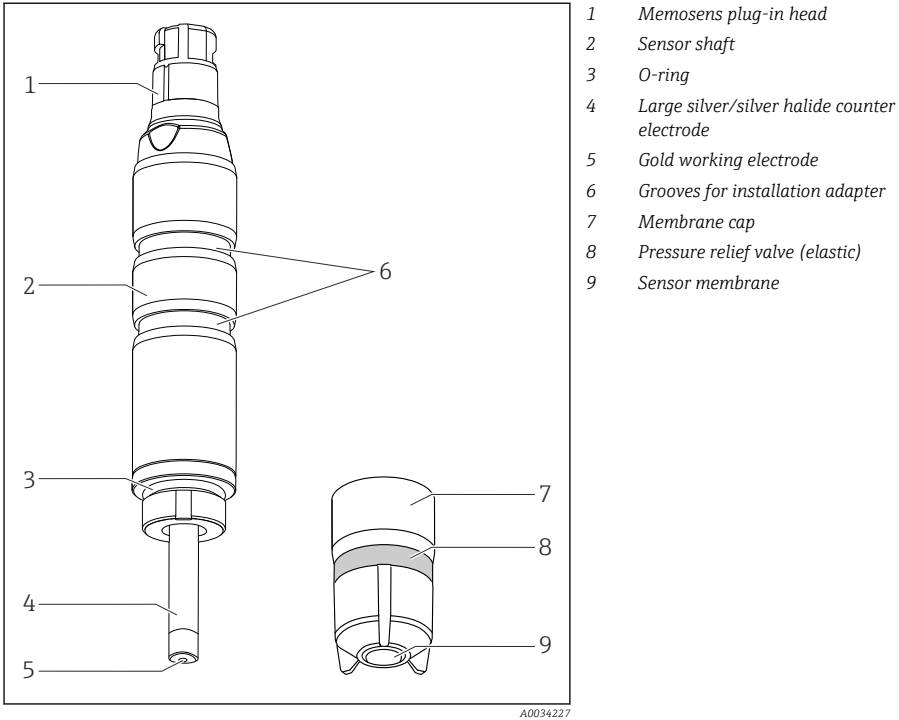

1 Sensor structure

## 2 Intended use

- Parts from the kits must only be used as maintenance parts for CCS5x(D/E) sensors. Any other use is not permitted!
- Only use original parts from Endress+Hauser.
- In the Device Viewer, check if the spare part is suitable for the device in question.

## 3 Authorized installation personnel

- Installation, commissioning, operation and maintenance of the measuring system may be carried out only by specially trained technical personnel.
- The technical personnel must be authorized by the plant operator to perform the stated tasks.
- The electrical connection may only be established by an electrical technician.

- The technical personnel must have read and understood these Installation Instructions and must follow the instructions they contain.
- Measuring point faults may be repaired only by authorized and specially trained personnel.
- In the case of Ex-certified devices, the technical staff must also be trained in explosion protection.

 Repairs not described in the Operating Instructions provided must only be carried out directly at the manufacturer's site or by the service organization.

## 4 Safety instructions

### CAUTION

#### **Risk to health due to the removal of sensors from the process!**

- ▶ When removing a sensor from the process, pay attention to pressure, process temperature and the corrosiveness or toxicity of the medium.

### CAUTION

#### **Risk to health due to contact with the process medium!**

- ▶ Pay attention to the warnings in the safety data sheets.
- ▶ Wear protective gloves, protective goggles and protective clothing, particularly when working with reagents, chemicals or process solutions.
- ▶ In case of contact with eyes or skin, rinse the affected area with plenty of water and then seek medical advice. Show the relevant safety data sheet to the physician.

#### **Potential impact on the process**

Before decommissioning an active device, the potential impact on the overall process must be taken into account! This applies in particular when using the switching contacts, the analog signal outputs or the communication interface of the associated measuring instrument to control process variables. Coordinate service tasks with the operator!

#### **Electrical safety**

The sensor operates exclusively with protective extra-low voltage. Therefore there is no electrical hazard.

## 5 Scope of delivery

The scope of delivery is stored in the Spare Parts Finder (SFT) as a components sheet. The QR code below enables access to the scope of delivery including an overview of devices with the item numbers of the maintenance parts. The order code, product root or serial number of the device must be entered for this purpose.



A0058993

<https://sft-p.cdn.endress.com/>

## 6 Cleaning the sensor

### ⚠ CAUTION

#### Diluted hydrochloric acid

Hydrochloric acid causes irritation if it comes into contact with the skin or eyes.

- ▶ When using diluted hydrochloric acid, wear protective clothing such as gloves and goggles.
- ▶ Avoid splashes.

### NOTICE

#### Chemicals that reduce surface tension (e.g. surfactants in cleaning agents or organic solvents that can be mixed with water, such as alcohol)

Chemicals that reduce the surface tension cause the sensor membrane to lose its special property and protective function, which results in measurement errors.

- ▶ Do not use any chemicals that reduce surface tension.

### 6.1 Cleaning the sensor membrane

If the membrane is visibly contaminated, e.g. biofilm, proceed as follows:

1. Remove sensor from flow assembly.
2. Remove the membrane cap.
3. Clean the membrane cap only mechanically using a gentle water jet, or clean it for several minutes in diluted acids or specified cleaning agents without additional chemical additives.

4. Then rinse thoroughly with water.
5. Fill the membrane cap with fresh electrolyte.
6. Screw the membrane cap back onto the sensor .

## 6.2 Cleaning the electrode body

1. Remove sensor from flow assembly.
2. Remove the membrane cap.

### Polishing the gold cathode

Polishing the gold cathode is not absolutely necessary. However, it helps to improve application-related issues such as low sensor slope, low concentration readings, deviations between DPD and sensor measured values, or sensor drift.

3. Apply a drop of water to the green polishing foil.
4. Rotate the sensor tip in the drop for 1 minute. Use the rough surface of the polishing foil.
5. Rinse the gold electrode with deionized water. Caution: The silver reference electrode must not be polished, as this will damage the sensor.

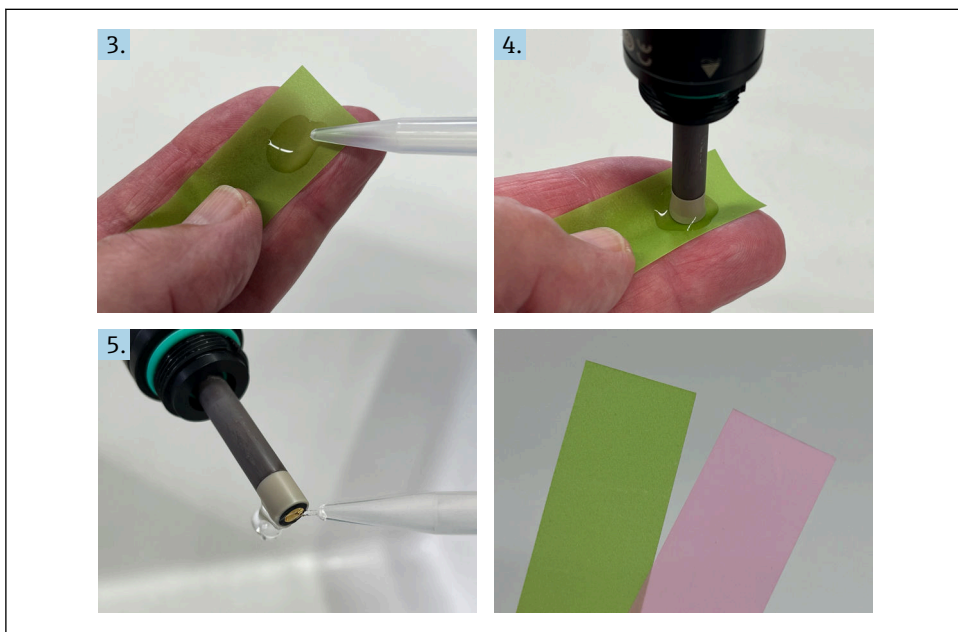

A0061850

6. Place a drop of water on the pink polishing foil and rotate the sensor tip in the drop for 1–2 minutes. The pink film generates a smooth and uniform surface. After polishing, the gold electrode must appear shiny.
7. If the gold electrode appears dull, scratched or uneven, repeat the process (step 6) with the pink polishing foil until a uniform, shiny surface is achieved.
8. Then rinse the gold electrode with deionized water.
9. Rinse electrode body with demineralized water.

 If the sensor slope is low, isopropyl alcohol must also be used to clean the reference electrode.

10. Fill the membrane cap with fresh electrolyte.
11. Screw the membrane cap back onto the sensor .

## 7 Replacing the membrane cap

The CCV05-5xA maintenance kits are used when a membrane cap needs to be replaced.

Possible causes include:



- Membrane perforated
- Membrane overstretched
- Membrane heavily contaminated
- Membrane damaged by surfactants or organic solvents.

 The membrane and electrolyte are subject to aging and continuous consumption.

Replace the membrane cap and electrolyte at least once a year.

Increased load on the sensor, e.g. due to high medium temperature and/or high chemical concentration in the medium, requires shorter maintenance intervals.

### 7.1 Replacing the membrane cap (CCV05-5xA maintenance kits)

1. Remove the sensor from the flow assembly .
2. Remove the membrane cap →  8.
3. Pour approx. 7 ml (0.24 fl oz) of electrolyte into the membrane cap up to the start of the internal thread. Fill the electrolyte without introducing bubbles. The electrolyte for CCS53E and CCS55D/E is viscous.
4. Check that the O-ring is present on the sensor and is in good condition (→  1,  4, item 3).
5. Slowly screw on the membrane cap up to the stop and ensure that there is no gap between the sensor body and the cap. Excess electrolyte will be forced out at the valve and at the thread. **Caution:** Do not accidentally block the valve opening when screwing on the cap.

6. Reset the operating hours counter for the membrane cap on the transmitter. For detailed information, see the Operating Instructions for the transmitter.
7. Calibrate the sensor after replacing the cap in accordance with the sensor operating instructions.

### Removing the membrane cap

1. Carefully rotate the membrane cap.

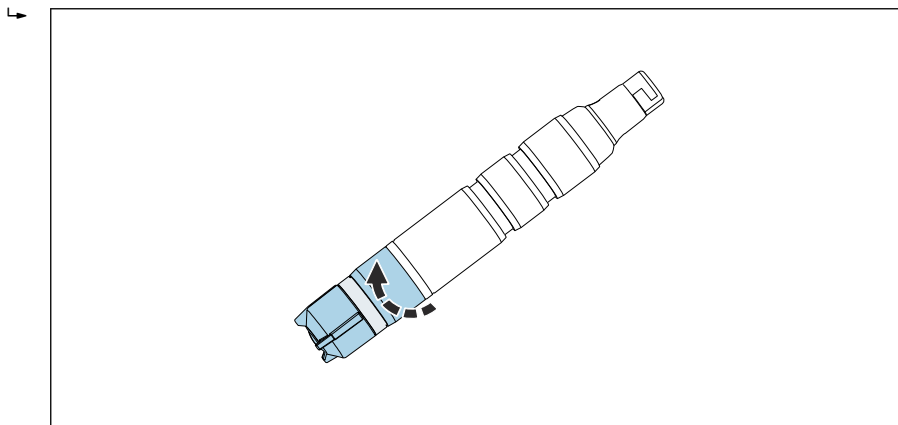

A0034406

2. Carefully remove the membrane cap.

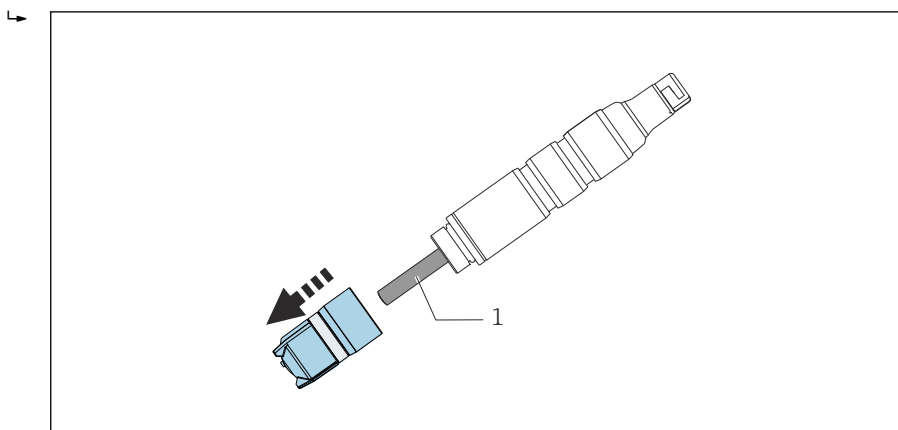

A0034408

1 Electrode body

### Screwing the membrane cap onto the sensor

- ▶ Screw the membrane cap onto the sensor shaft: hold the sensor by the shaft. Do not block the valve.

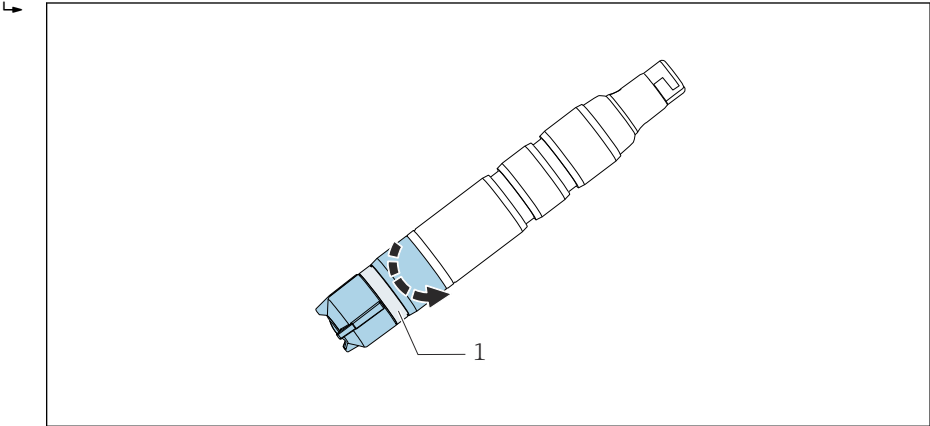



A0034480

 2 *Screwing on the membrane cap: do not block the pressure relief valve.*



1 *Pressure relief valve*

## 8 Electrolyte replacement (CCV05-5xB maintenance kits)

1. Remove the membrane cap →  9.
2. Empty the membrane cap and check it for damage or contamination.
3. If necessary, replace a damaged membrane cap or clean a contaminated membrane cap.
4. Refill the membrane cap in accordance with step 3 →  8.
5. Calibrate the sensor after replacing the electrolyte in accordance with the sensor operating instructions.
6. Reset the operating hours counter for the electrolyte on the transmitter (if the function is available; detailed information can be found in the Operating Instructions for the transmitter).

## 9 Replacing the seals (CCV05-5xC seal set)

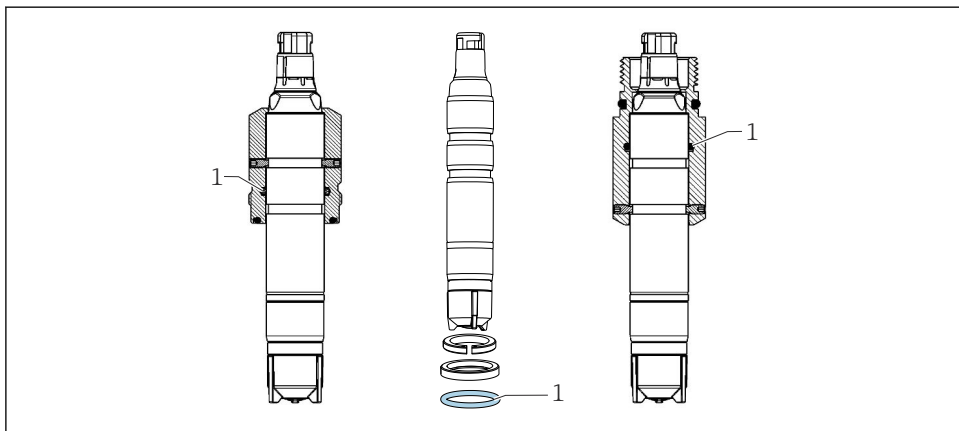

 Observe the safety instructions in the "Safety instructions" section →  5. Use the individual parts of the seal set as described below.

**O-ring ID 25.07 W 2.62 mm, FKM** (→  3,  11, item 1): This O-ring seals the sensor shaft against the CYA27 or CCA151 assembly, or against the adapter for CCA250 or CYA112.



A0061769

 3 O-ring ID 25.07 W 2.62 mm, FKM

**O-ring ID 16.00 W 2.00 mm, FKM** (→  4,  12, item 1): This O-ring seals the electrode body against the process.

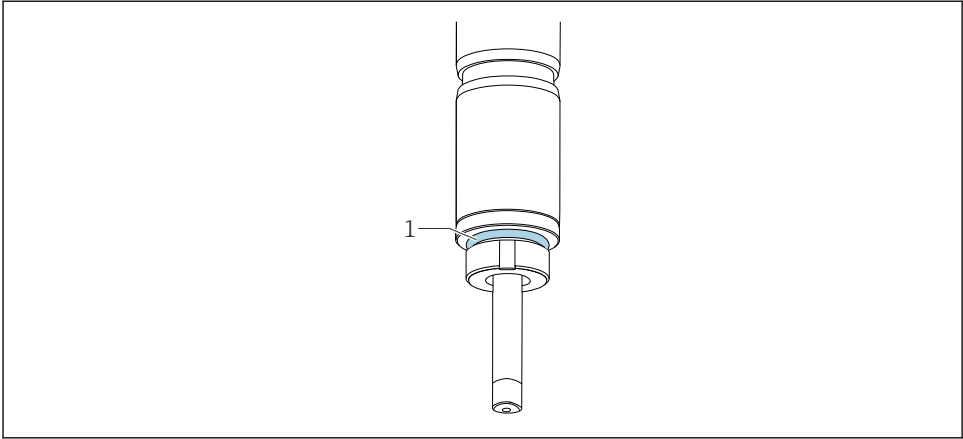

A0061770

▣ 4 O-ring ID 16.00 W 2.00 mm, FKM

**O-ring ID 29.82 W 2.62 mm, FKM (→ ▣ 5, 📄 12, item 1):** This O-ring seals the adapter for CCA250 against the process.

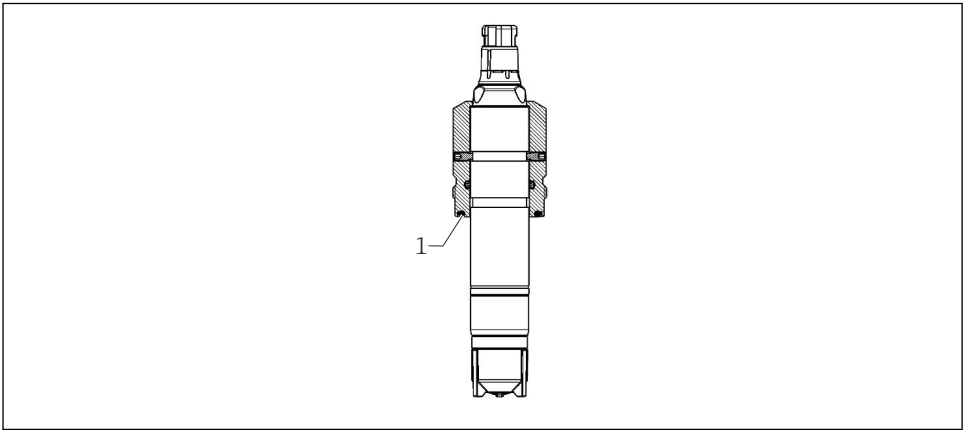

A0061793

▣ 5 O-ring ID 29.82 W 2.62 mm, FKM

**Valve ring for membrane cap (→ ▣ 6, 📄 13, item 1):** This sealing ring seals the ventilation opening in the membrane cap and prevents the electrolyte from leaking.

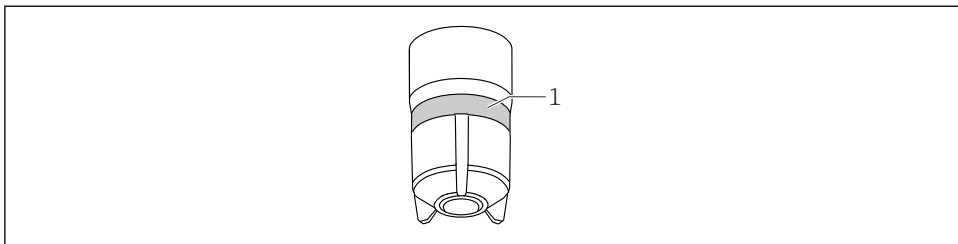

A0061794

 6 Valve ring for membrane cap

## 10 Additional documentation

Detailed information on the device can be found in the Operating Instructions for the sensor and in the other documentation available via:

- [www.endress.com/device-viewer](http://www.endress.com/device-viewer)
- Smartphone/tablet: Endress+Hauser Operations app

## 11 Disposal

-  If required by the Directive 2012/19/EU on waste electrical and electronic equipment (WEEE), the product is marked with the depicted symbol in order to minimize the disposal of WEEE as unsorted municipal waste. Do not dispose of products bearing this marking as unsorted municipal waste. Instead, return them to the manufacturer for disposal under the applicable conditions.







71765398

[www.addresses.endress.com](http://www.addresses.endress.com)

---