

Operating Instructions

Waterpilot FMX21

Hydrostatic level measurement
4 to 20 mA HART

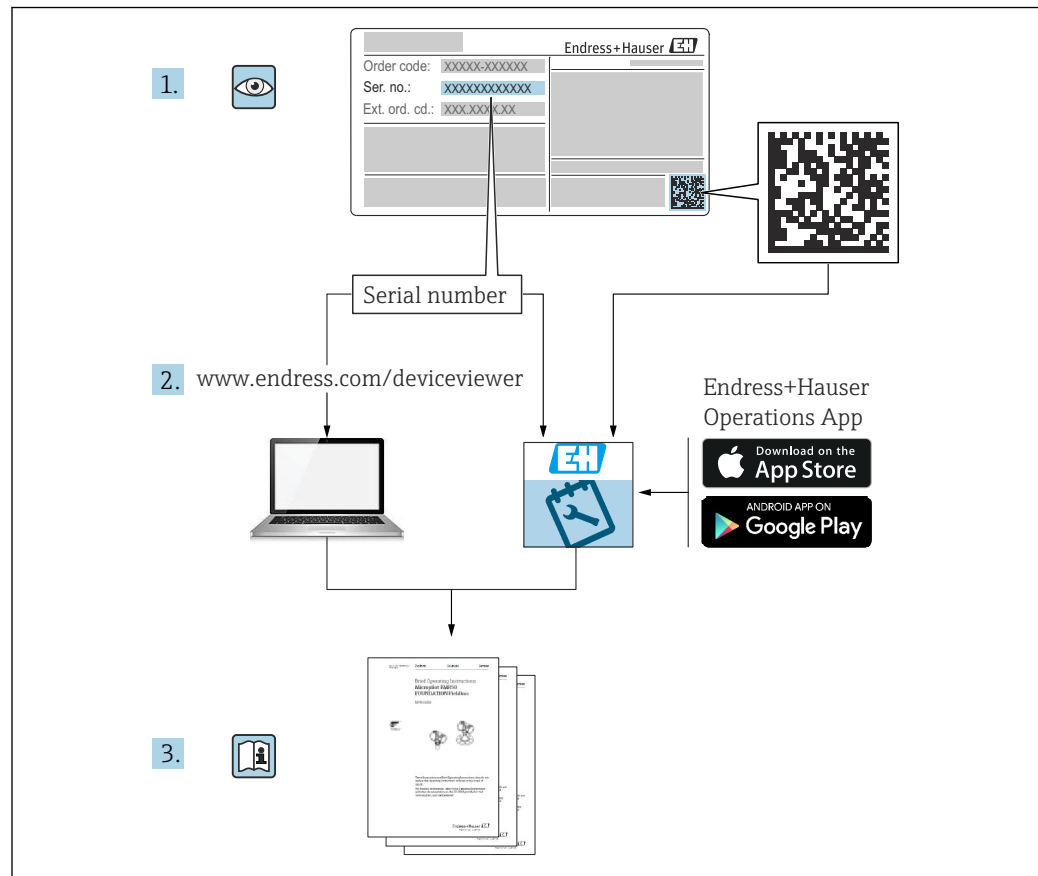



A0023555

- Make sure the document is stored in a safe place such that it is always available when working on or with the device.
- To avoid hazards for individuals or the facility, read the "Basic safety instructions" section carefully, as well as all other safety instructions in the document that are specific to working procedures.
- The manufacturer reserves the right to modify technical data without prior notice. Your Endress+Hauser distributor will supply you with current information and updates to this manual.

Table of contents

1	About this document	5	6.2	Supply voltage	27
1.1	Document function	5	6.3	Cable specifications	27
1.2	Safety symbols	5	6.4	Power consumption	27
1.3	Electrical symbols	5	6.5	Current consumption	27
1.4	Tool symbols	5	6.6	Connecting the measuring unit	28
1.5	Symbols for certain types of Information	6	6.7	Post-connection check	31
1.6	Symbols in graphics	6			
1.7	Documentation	6	7	Operation options	33
1.8	Registered trademarks	7	7.1	Overview of operation options	33
1.9	Terms and abbreviations	8	7.2	Operation concept	34
1.10	Turn down calculation	8	7.3	Structure of the operating menu	35
			7.4	Locking/unlocking operation	35
2	Basic safety requirements	10	8	Integrating device via HART[®] protocol	37
2.1	Requirements for the personnel	10	8.1	HART process variables and measured values	37
2.2	Intended use	10	8.2	Device variables and measured values	38
2.3	Workplace safety	10			
2.4	Operational safety	10	9	Commissioning	39
2.5	Product safety	11	9.1	Function check	39
3	Product description	12	9.2	Unlocking/locking configuration	39
3.1	Mode of operation	12	9.3	Commissioning	39
4	Incoming acceptance and product identification	13	9.4	Selecting the measuring mode	39
4.1	Incoming acceptance	13	9.5	Selecting the pressure engineering unit	40
4.2	Product identification	13	9.6	Position adjustment	40
4.3	Identification of sensor type	13	9.7	Configuring the damping	41
4.4	Manufacturer address	14	9.8	Configuring pressure measurement	42
4.5	Storage and transport	14	9.9	Configuring level measurement	44
5	Installation	15	9.10	Automatic density compensation	55
5.1	Installation requirements	15	9.11	Linearization	58
5.2	Additional mounting instructions	16	9.12	Manual entry of a linearization table via operating tool	61
5.3	Dimensions	16	9.13	Backing up or duplicating the device data	61
5.4	Installation of the Waterpilot with a suspension clamp	17	9.14	Operation and settings via RIA15	62
5.5	Mounting the device with a cable mounting screw	18	10	Diagnostics and troubleshooting	67
5.6	Mounting the terminal box	19	10.1	General troubleshooting	67
5.7	Mounting the TMT72 temperature head transmitter with terminal box	19	10.2	Diagnostic events in the operating tool	67
5.8	Mounting the terminal strip for the Pt100 passive (without TMT72)	20	10.3	Troubleshooting specific to the device with optional Pt100	73
5.9	Inserting the cable into the RIA15 field housing	21	10.4	Troubleshooting specific to TMT72 temperature head transmitter	73
5.10	Cable marking	21	10.5	Response of output to failures	74
5.11	Cable shortening kit	22	10.6	Resetting the device	74
5.12	Post-mounting check	22	11	Maintenance	76
6	Electrical connection	23	11.1	Exterior cleaning	76
6.1	Connecting the device	23	12	Repair	77
			12.1	General information	77

12.2	Spare parts	77
12.3	Return	77
12.4	Disposal	77
13	Overview of the operating menu	78
13.1	Overview of parameters in the "Expert" menu .	81
14	Description of device parameters ...	86
14.1	Expert → System	86
14.2	Expert → System → Instrument info	87
14.3	Expert → System → Management	89
14.4	Expert → Measurement → Measuring mode ..	89
14.5	Expert → Measurement → Basic setup	90
14.6	Expert → Measurement → Pressure	92
14.7	Expert → Measurement → Level	94
14.8	Expert → Measurement → Linearization	99
14.9	Expert → Measurement → Sensor limits	102
14.10	Expert → Measurement → Sensor trim	103
14.11	Expert → Output → Current output	104
14.12	Expert → Communication → HART config. ...	108
14.13	Expert → Communication → HART info	110
14.14	Expert → Communication → HART output ...	112
14.15	Expert → Communication → HART input	115
14.16	Expert → Application	117
14.17	Expert → Diagnosis	118
14.18	Expert → Diagnosis → Diagnostic list	120
14.19	Expert → Diagnosis → Event logbook	121
14.20	Expert → Diagnosis → Simulation	122
15	Accessories	124
15.1	Device-specific accessories	124
15.2	Service-specific accessories	127
16	Technical data	128
16.1	Input	128
16.2	Output	130
16.3	Performance characteristics	133
16.4	Environment	135
16.5	Process	137
16.6	Additional technical data	138
Index	139	

1 About this document

1.1 Document function

These Operating Instructions contain all the information required in the various life cycle phases of the device: from product identification, incoming acceptance and storage, to installation, connection, operation and commissioning, through to troubleshooting, maintenance and disposal.

1.2 Safety symbols

DANGER

This symbol alerts you to a dangerous situation. Failure to avoid this situation will result in serious or fatal injury.

WARNING

This symbol alerts you to a potentially dangerous situation. Failure to avoid this situation can result in serious or fatal injury.

CAUTION

This symbol alerts you to a potentially dangerous situation. Failure to avoid this situation can result in minor or medium injury.

NOTICE

This symbol alerts you to a potentially harmful situation. Failure to avoid this situation can result in damage to the product or something in its vicinity.

1.3 Electrical symbols



Direct current



Alternating current



Direct current and alternating current



Ground connection

Grounded clamp, which is grounded via a grounding system.



Protective earth (PE)

Ground terminals, which must be grounded prior to establishing any other connections.

The ground terminals are located on the inside and outside of the device.



Equipotential connection

A connection that has to be connected to the plant grounding system: This may be a potential equalization line or a star grounding system depending on national or company codes of practice.

1.4 Tool symbols



Flat blade screwdriver



Phillips screwdriver



Allen key



Open-ended wrench

1.5 Symbols for certain types of Information

Permitted

Procedures, processes or actions that are permitted

Preferred

Procedures, processes or actions that are preferred

Forbidden

Procedures, processes or actions that are forbidden

Tip

Indicates additional information



Reference to documentation



Reference to page



Reference to graphic

1, 2, 3

Series of steps



Result of a step



Help in the event of a problem



Visual inspection

1.6 Symbols in graphics

1, 2, 3, ...

Item numbers

1, 2, 3

Series of steps

A, B, C, ...

Views

A-A, B-B, C-C etc.

Sections

1.7 Documentation

The following document types are available in the Downloads area of the Endress+Hauser website (www.endress.com/downloads):



For an overview of the scope of the associated Technical Documentation, refer to the following:

- *Device Viewer* (www.endress.com/deviceviewer): Enter the serial number from the nameplate
- *Endress+Hauser Operations app*: Enter serial number from nameplate or scan matrix code on nameplate.

1.7.1 Technical Information (TI)

Planning aid

The document contains all the technical data on the device and provides an overview of the accessories and other products that can be ordered for the device.

1.7.2 Brief Operating Instructions (KA)

Guide that takes you quickly to the 1st measured value

The Brief Operating Instructions contain all the essential information from incoming acceptance to initial commissioning.

1.7.3 Safety Instructions (XA)

Depending on the approval, the following Safety Instructions (XA) are supplied with the device. They are an integral part of the Operating Instructions.

 The nameplate indicates the Safety Instructions (XA) that are relevant to the device.

1.8 Registered trademarks

1.8.1 GORE-TEX®

Trademark of W.L. Gore & Associates, Inc., USA.

1.8.2 TEFLON®

Trademark of E.I. Du Pont de Nemours & Co., Wilmington, USA.

1.8.3 HART®

Registered trademark of the FieldComm Group, Austin, USA

1.8.4 FieldCare®

Trademark of Endress+Hauser Process Solutions AG.

1.8.5 DeviceCare®

Trademark of Endress+Hauser Process Solutions AG.

1.8.6 iTEMP®

Trademark of Endress+Hauser Wetzler GmbH + Co. KG, Nesselwang, D..

1.9 Terms and abbreviations

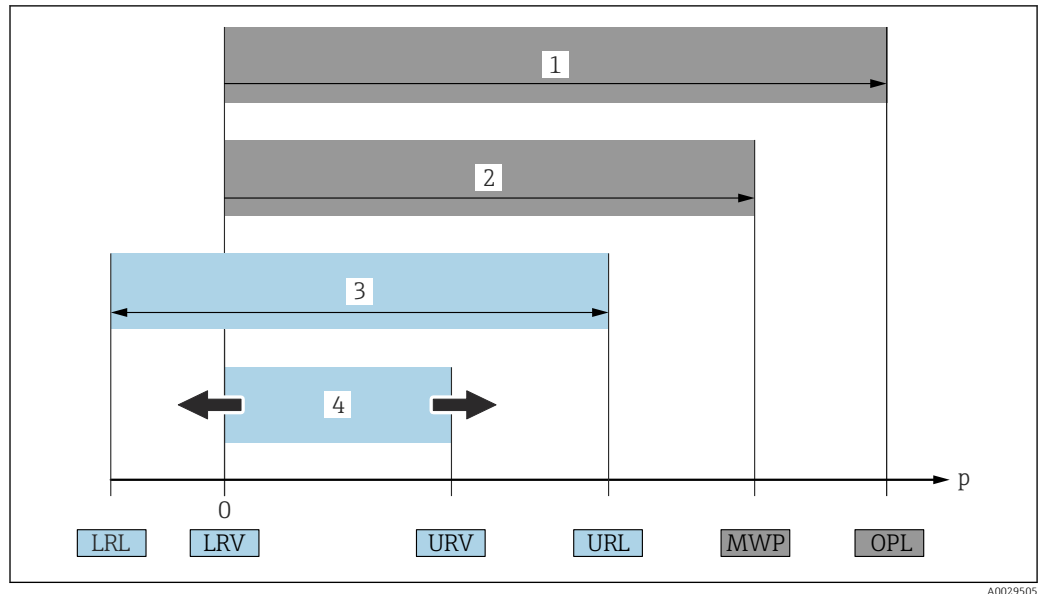

- 1 OPL: The OPL (over pressure limit = measuring cell overpressure limit) for the device depends on the lowest-rated element, with regard to pressure, of the selected components, i.e. the process connection must be taken into consideration in addition to the measuring cell. Observe pressure-temperature dependency. OPL (Over Pressure Limit) is a test pressure.
- 2 MWP: The MWP (maximum working pressure) for the measuring cells depends on the lowest-rated element, with regard to pressure, of the selected components, i.e. the process connection also has to be taken into consideration besides the measuring cell. Observe pressure-temperature dependency. The maximum working pressure may be applied to the device for an unlimited period of time. The maximum working pressure can be found on the nameplate.
- 3 The maximum measuring range corresponds to the span between the lower range limit and upper range limit. This measuring range is equivalent to the maximum span that can be calibrated/adjusted.
- 4 The calibrated/adjusted measuring span corresponds to the span between the lower range limit and upper range limit. Factory setting: 0 to upper range limit. Other calibrated spans can be ordered as customized measuring spans.

p Pressure
 LRL Lower range limit
 URL Upper range limit
 LRV Lower range value
 URV Upper range value
 TD Turn down Example - see the following section.
 PE Polyethylene
 FEP Fluorinated ethylene propylene
 PUR Polyurethane

1.10 Turn down calculation

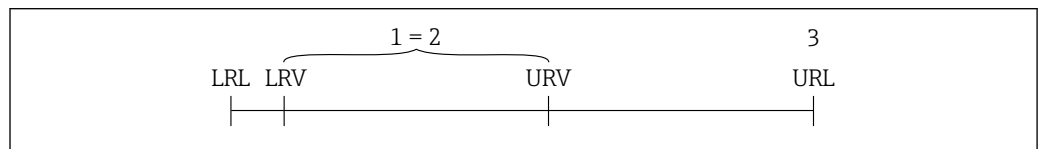

- 1 Calibrated/adjusted measuring span
- 2 Zero point-based span
- 3 Upper range limit

Example:

- Measuring cell: 10 bar (150 psi)
- Upper range limit (URL) = 10 bar (150 psi)
- Calibrated/adjusted measuring span: 0 to 5 bar (0 to 75 psi)
- Lower range value (LRV) = 0 bar (0 psi)
- Upper range value (URV) = 5 bar (75 psi)

$$\text{TD} = \frac{\text{URL}}{|\text{URV} - \text{LRV}|}$$

In this example, the TD is 2:1. This span is based on the zero point.

2 Basic safety requirements

2.1 Requirements for the personnel

The personnel for installation, commissioning, diagnostics and maintenance must fulfill the following requirements:

- ▶ Trained, qualified specialists must have a relevant qualification for this specific function and task.
- ▶ Are authorized by the plant owner/operator.
- ▶ Are familiar with federal/national regulations.
- ▶ Before starting work, read and understand the instructions in the manual and supplementary documentation as well as the certificates (depending on the application).
- ▶ Follow instructions and comply with basic conditions.

The operating personnel must fulfill the following requirements:

- ▶ Are instructed and authorized according to the requirements of the task by the facility's owner-operator.
- ▶ Follow the instructions in this manual.

2.2 Intended use

2.2.1 Application and media

Der Waterpilot FMX21 is a hydrostatic pressure sensor for measuring the level of fresh water, wastewater and salt water. The temperature is measured simultaneously in the case of sensor versions with a Pt100 resistance thermometer.

An optional temperature head transmitter converts the Pt100 signal to a 4 to 20 mA signal with superimposed digital communication protocol HART 6.0.

2.2.2 Incorrect use

The manufacturer is not liable for harm caused by improper or non-designated use.

Clarification for borderline cases:

- ▶ For special fluids and fluids for cleaning, Endress+Hauser is glad to provide assistance in verifying the corrosion resistance of fluid-wetted materials, but does not accept any warranty or liability.

2.3 Workplace safety

For work on and with the device:

- ▶ Wear the required personal protective equipment according to federal/national regulations.

2.4 Operational safety

Damage to the device!

- ▶ Operate the device in proper technical condition and fail-safe condition only.
- ▶ The operator is responsible for the interference-free operation of the device.

Modifications to the device

Unauthorized modifications to the device are not permitted and can lead to unforeseeable dangers!

- ▶ If modifications are nevertheless required, consult with the manufacturer.

Repair

To ensure continued operational safety and reliability:

- ▶ Carry out repairs on the device only if they are expressly permitted.
- ▶ Observe federal/national regulations pertaining to the repair of an electrical device.
- ▶ Use only original spare parts and accessories.

2.5 Product safety

This state-of-the-art device is designed and tested in accordance with good engineering practice to meet operational safety standards. It left the factory in a condition in which it is safe to operate.

It meets general safety standards and legal requirements. It also complies with the EU directives listed in the device-specific EU declaration of conformity. The manufacturer confirms this by affixing the CE mark.

3 Product description

3.1 Mode of operation

The ceramic measuring cell is a dry measuring cell, i.e. the pressure acts directly on the robust, ceramic process membrane of the Waterpilot FMX21. Changes in atmospheric pressure are guided via a pressure compensation tube through the supporting cable to the rear of the ceramic process membrane and are compensated for. A pressure-dependent change in capacitance, caused by the movement of the process membrane, is measured at the electrodes of the ceramic carrier. The electronics unit then converts this to a signal that is proportional to the pressure and linear to the level.

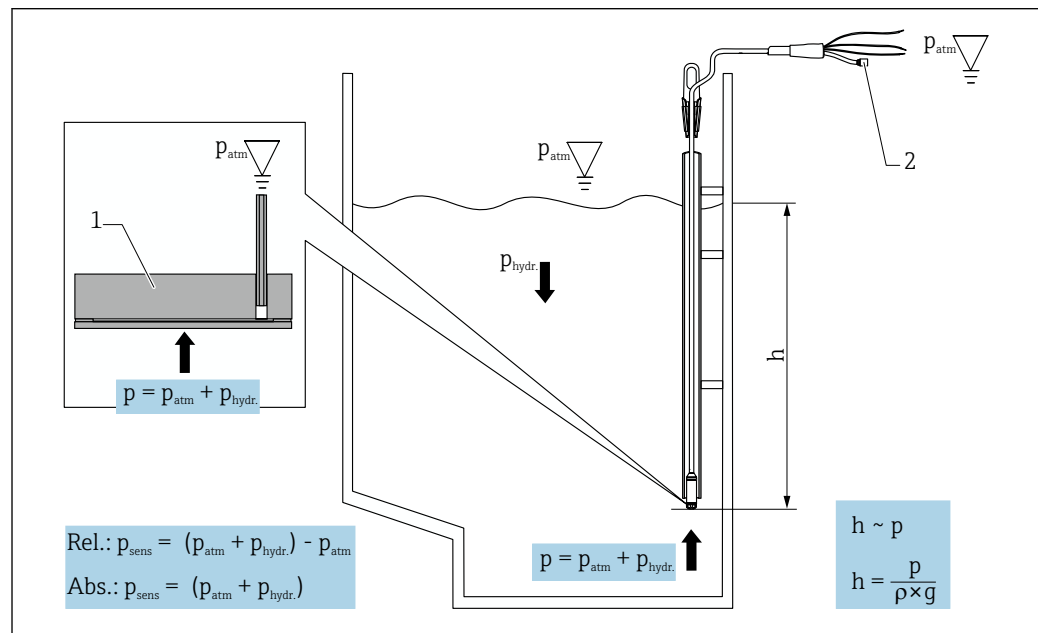

A0019140

- 1 Ceramic measuring cell
- 2 Pressure compensation tube
- h Level height
- p Total pressure = atmospheric pressure + hydrostatic pressure
- ρ Density of the medium
- g Acceleration of free fall
- $p_{\text{hydr.}}$ Hydrostatic pressure
- p_{atm} Atmospheric pressure
- p_{sens} Pressure indicated by the sensor

4 Incoming acceptance and product identification

4.1 Incoming acceptance

On receipt of the delivery:

1. Check the packaging for damage.
 - ↳ Report all damage immediately to the manufacturer.
Do not install damaged components.
2. Check the scope of delivery using the delivery note.
3. Compare the data on the nameplate with the order specifications on the delivery note.
4. Check the technical documentation and all other necessary documents, e.g. certificates, to ensure they are complete.



If one of the conditions is not satisfied, contact the manufacturer.

4.2 Product identification

The following options are available for identification of the device:

- Nameplate specifications
- Order code with breakdown of the device features on the delivery note
- Enter the serial numbers from the nameplates in *Device Viewer* (www.endress.com/deviceviewer): all the information about the device is displayed.

4.2.1 Nameplate

Do you have the correct device?

The nameplate provides you with the following information on the device:

- Manufacturer identification, device designation
 - Order code
 - Extended order code
 - Serial number
 - Tag name (TAG) (optional)
 - Technical values such as supply voltage, current consumption, ambient temperature, communication-specific data (optional)
 - Degree of protection
 - Approvals with symbols
 - Reference to Safety Instructions (XA) (optional)
- ▶ Compare the information on the nameplate with the order.

4.3 Identification of sensor type

With gauge pressure or absolute pressure sensors, the "Pos. zero adjust" parameter is displayed in the operating menu. With absolute pressure sensors, the "Calib. offset" parameter is displayed in the operating menu.

4.4 Manufacturer address

Endress+Hauser SE+Co. KG
Hauptstraße 1
79689 Maulburg, Germany
Place of manufacture: See nameplate.

4.5 Storage and transport

4.5.1 Storage conditions

Use original packaging.

Store the measuring device in clean and dry conditions and protect from damage caused by shocks (EN 837-2).

Storage temperature range

Device + Pt100 (optional)

-40 to +80 °C (-40 to +176 °F)

Cable

(when mounted in a fixed position)

- With PE: -30 to +70 °C (-22 to +158 °F)
- With FEP: -30 to +80 °C (-22 to +176 °F)
- With PUR: -40 to +80 °C (-40 to +176 °F)

Terminal box

-40 to +80 °C (-40 to +176 °F)

TMT72 temperature head transmitter (optional)

-40 to +100 °C (-40 to +212 °F)

4.5.2 Transporting the product to the measuring point

WARNING

Incorrect transport!

Device or cable may become damaged, and there is a risk of injury!

- ▶ Transport measuring device in the original packaging.
- ▶ Follow the safety instructions and transport conditions for devices weighing more than 18 kg (39.6 lbs).

5 Installation

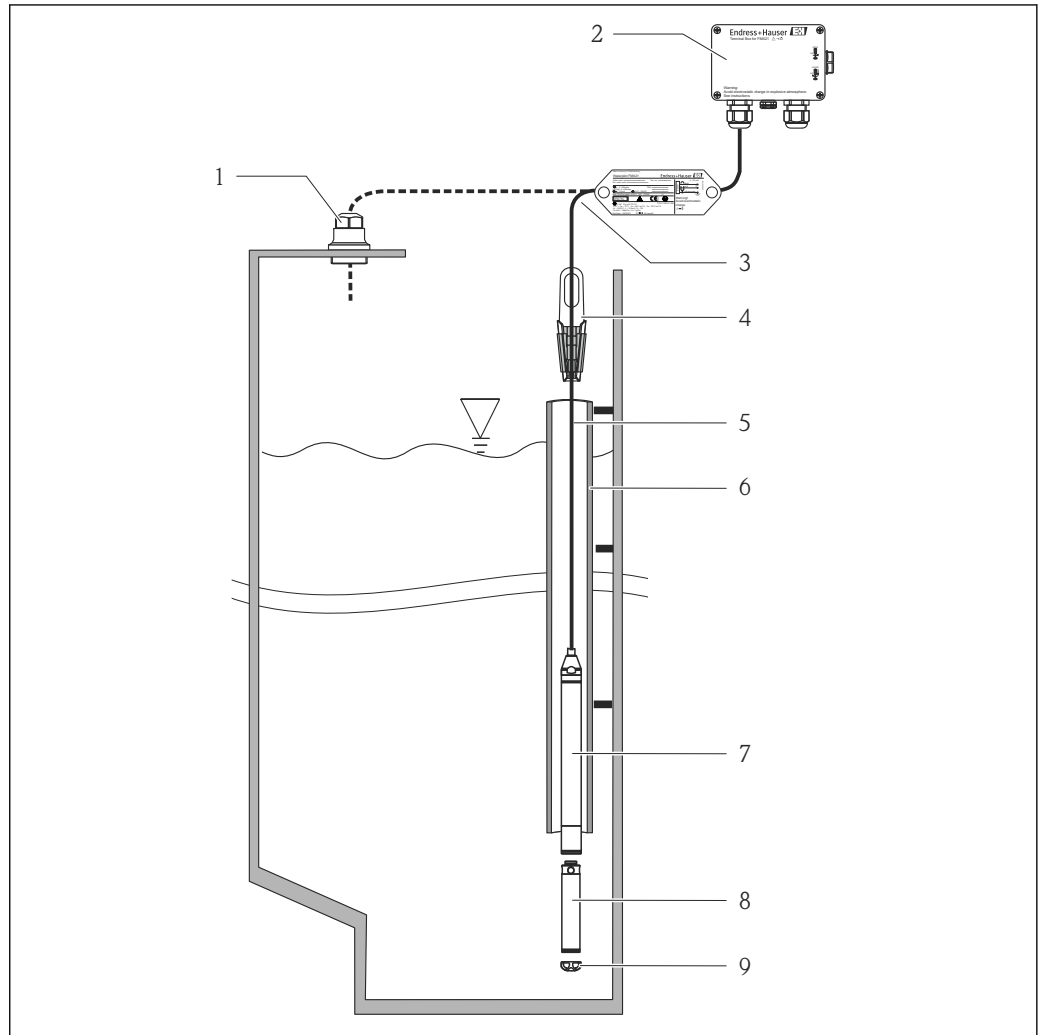

5.1 Installation requirements



A0018770

- 1 Cable mounting screw (can be ordered as an accessory)
- 2 Terminal box (can be ordered as an accessory)
- 3 Bending radius of extension cable > 120 mm (4.72 in)
- 4 Suspension clamp (can be ordered as an accessory)
- 5 Extension cable
- 6 Guide tube
- 7 Device
- 8 Additional weight can be ordered as an accessory for the device with external diameter of 22 mm (0.87 in) and 29 mm (1.14 in)
- 9 Protective cap

5.2 Additional mounting instructions

- Cable length
 - Customer-specific in meters or feet.
 - Limited cable length when performing installation with freely suspended device with cable mounting screw or mounting clamp, as well as for FM/CSA approval: max. 300 m (984 ft).
- Sideways movement of the level probe can result in measuring errors. For this reason, install the probe at a point free from flow and turbulence, or use a guide tube. The internal diameter of the guide tube should be at least 1 mm (0.04 in) greater than the external diameter of the selected FMX21.
- To avoid mechanical damage to the measuring cell, the device is equipped with a protection cap.
- The cable must end in a dry room or a suitable terminal box. The terminal box from Endress+Hauser provides humidity and climatic protection and is suitable for installation outdoors →  124.
- Cable length tolerance: < 5 m (16 ft): ± 17.5 mm (0.69 in); > 5 m (16 ft): ± 0.2 %
- If the cable is shortened, the filter at the pressure compensation tube must be reattached. Endress+Hauser offers a cable shortening kit for this purpose →  124 (documentation SD00552P/00/A6).
- Endress+Hauser recommends using twisted, shielded cable.
- In shipbuilding applications, measures are required to restrict the spread of fire along cable looms.
- The length of the extension cable depends on the intended level zero point. The height of the protection cap must be taken into consideration when designing the layout of the measuring point. The level zero point (E) corresponds to the position of the process isolating diaphragm. Level zero point = E; tip of probe = L (see the following diagram).

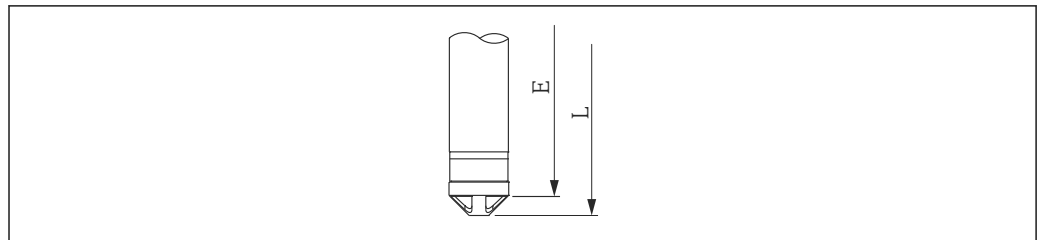

A0026013

5.3 Dimensions

For dimensions, see the Technical Information

5.4 Installation of the Waterpilot with a suspension clamp

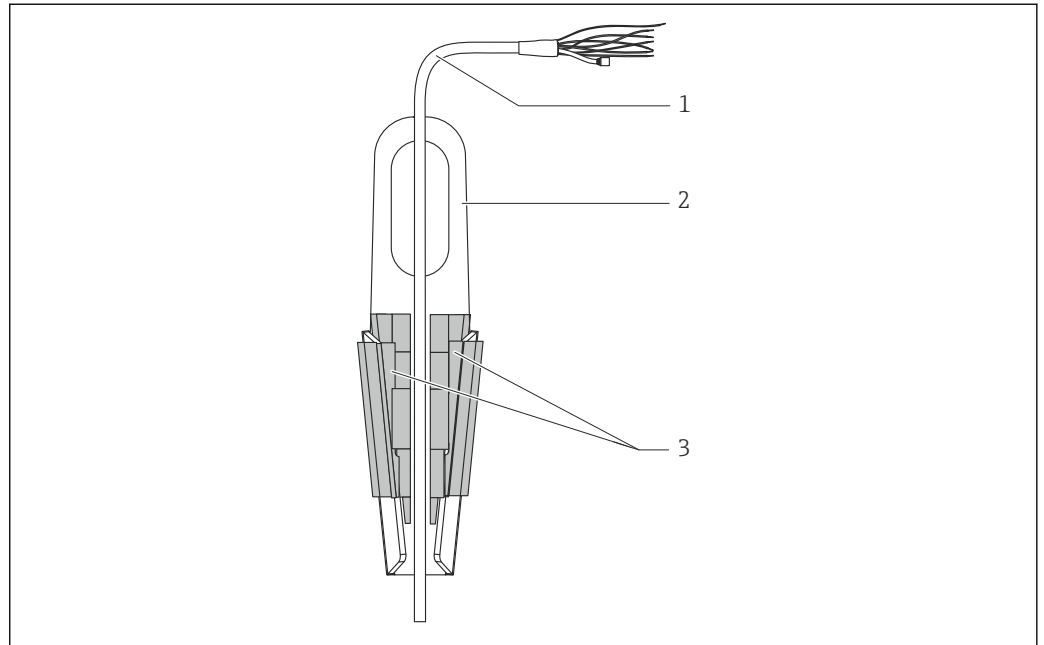

A0018793

- 1 Extension cable
- 2 Suspension clamp
- 3 Clamping jaw

5.4.1 Mounting the suspension clamp:

1. Mount the suspension clamp (item 2). Take the weight of the extension cable (item 1) and the device into account when selecting the fastening point.
2. Push up the clamping jaws (item 3). Place the extension cable (item 1) between the clamping jaws as shown in the graphic.
3. Hold the extension cable (item 1) in position and push the clamping jaws (item 3) back down. Tap the clamping jaws gently from above to fix them in place.

5.5 Mounting the device with a cable mounting screw

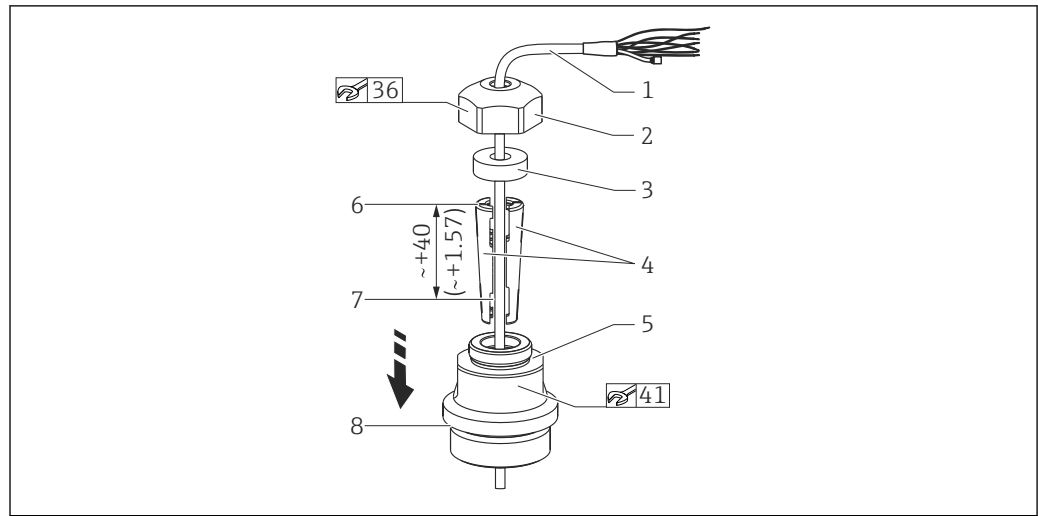

1 Illustrated with G 1½" thread. Unit of measurement mm (in)

- 1 Extension cable
- 2 Cover for cable mounting screw
- 3 Sealing ring
- 4 Clamping sleeves
- 5 Adapter for cable mounting screw
- 6 Top edge of clamping sleeve
- 7 Desired length of extension cable and Waterpilot probe prior to assembly
- 8 After assembly, item 7 is located next to the mounting screw with G 1½" thread: height of sealing surface of the adapter or NPT 1½" thread height of thread run-out of adapter

i If you want to lower the level probe to a certain depth, position the top edge of the clamping sleeve 40 mm (4.57 in) higher than the required depth. Then push the extension cable and the clamping sleeve into the adapter as described in Step 6 in the following section.

5.5.1 Mounting the cable mounting screw with a G 1½" or NPT 1½" thread:

1. Mark the desired length of extension cable on the extension cable.
2. Insert the probe through the measuring aperture and carefully lower on the extension cable. Fix the extension cable to prevent it from slipping.
3. Slide the adapter (item 5) over the extension cable and screw it tightly into the measuring aperture.
4. Slide the sealing ring (item 3) and cover (item 2) onto the cable from above. Press the sealing ring into the cover.
5. Place the clamping sleeves (item 4) around the extension cable (item 1) at the marked point as illustrated in the graphic.
6. Slide the extension cable with the clamping sleeves (item 4) into the adapter (item 5)
7. Fit the cover (item 2) with the sealing ring (item 3) onto the adapter (item 5) and securely screw together with the adapter.

i To remove the cable mounting screw, perform this sequence of steps in reverse.

CAUTION

Risk of injury!

- Use only in unpressurized vessels.

5.6 Mounting the terminal box

The optional terminal box is mounted using four screws (M4). For the dimensions of the terminal box, see the Technical Information

5.7 Mounting the TMT72 temperature head transmitter with terminal box

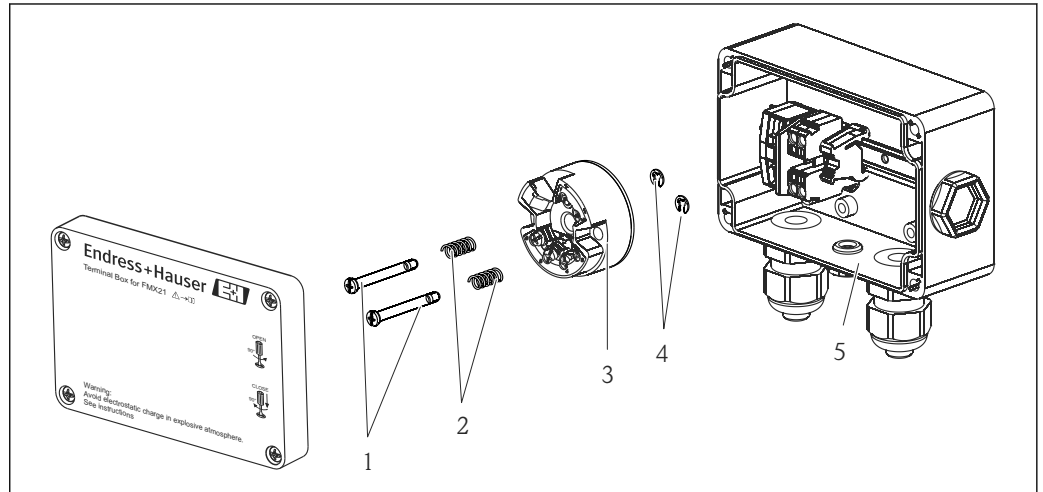

- 1 Mounting screws
- 2 Mounting springs
- 3 TMT72 temperature head transmitter
- 4 Retaining rings
- 5 Terminal box

i Only open the terminal box with a screwdriver.

WARNING

Explosion hazard!

- ▶ The TMT72 is not designed for use in hazardous areas.

5.7.1 Mounting the temperature head transmitter:

1. Guide the mounting screws (item 1) with the mounting springs (item 2) through the bore of the temperature head transmitter (item 3)
2. Secure the mounting screws with the circlips (item 4). Circlips, mounting screws and springs are included in the scope of delivery for the temperature head transmitter.
3. Screw the temperature head transmitter into the field housing tightly. (Width of screwdriver blade max. 6 mm (0.24 in))

NOTICE

Avoid damage to the temperature head transmitter.

- ▶ Do not overtighten the mounting screw.

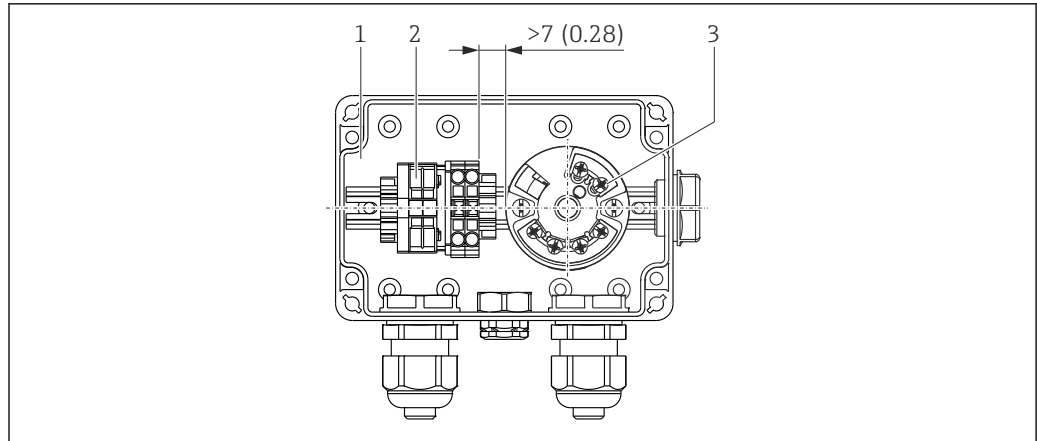

A0018696

Unit of measurement mm (in)

- 1 Terminal box
- 2 Terminal strip
- 3 TMT72 temperature head transmitter

NOTICE

Incorrect connection!

- ▶ A distance of > 7 mm (28 in) must be maintained between the terminal strip and the TMT72 temperature head transmitter.

5.8 Mounting the terminal strip for the Pt100 passive (without TMT72)

If the FMX21 with optional Pt100 is supplied without the optional TMT72 temperature head transmitter, a terminal strip is provided with the terminal box for the purpose of wiring the Pt100.

⚠ WARNING

Explosion hazard!

- ▶ The Pt100, as well as the terminal strip, are not designed for use in hazardous areas.

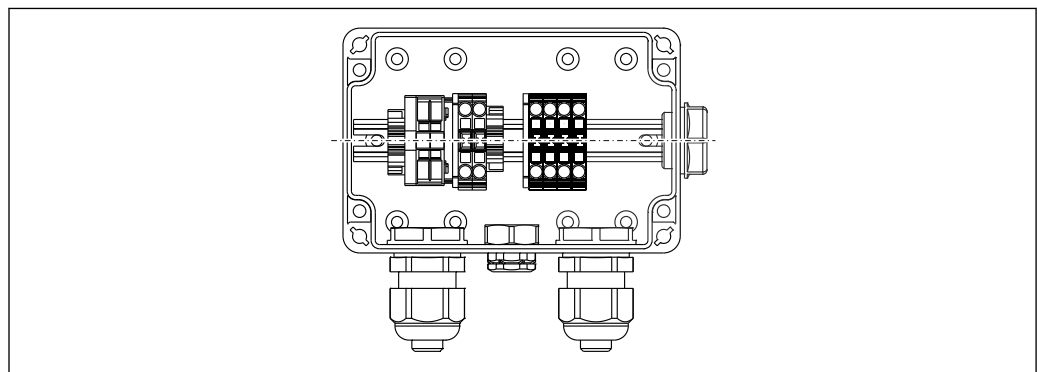

A0018815

5.9 Inserting the cable into the RIA15 field housing

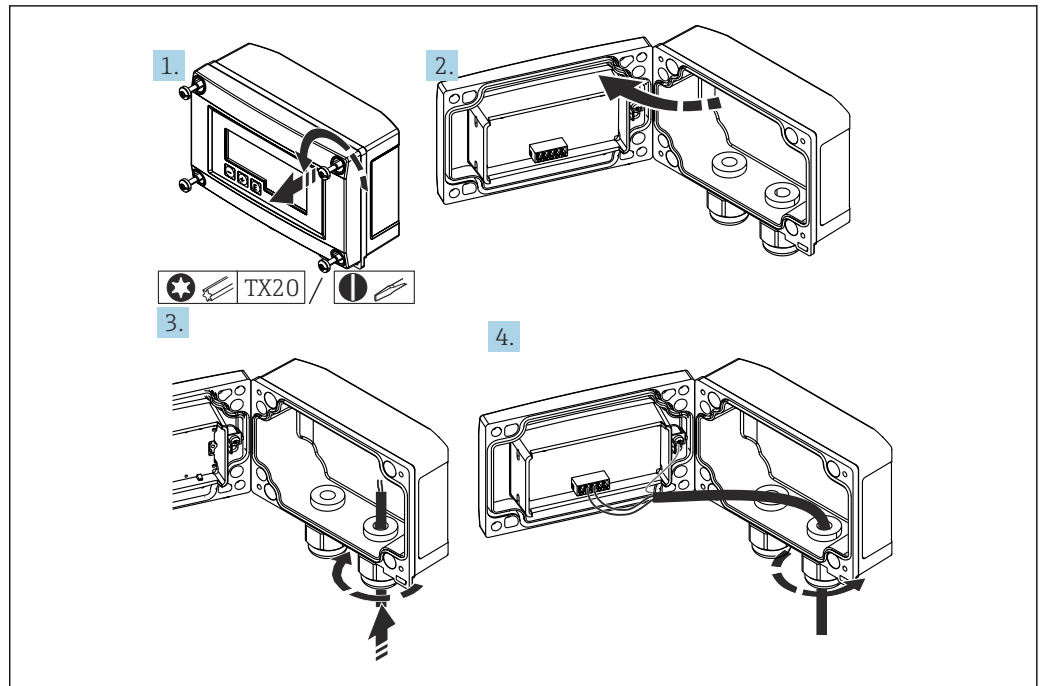

A0017830

Inserting the cable, field housing, connection without transmitter power supply (example)

1. Release the housing screws.
2. Opening the housing
3. Open the cable gland (M16) and insert the cable.
4. Connect the cable including the functional grounding and close the cable gland.

i Compensation of the atmospheric pressure must be ensured for the installation. A black, vented cable gland is supplied for this purpose.

If using the communication resistance module in the RIA15, the cable of the device must be inserted into the right gland when connecting the device so that the integrated pressure compensation tube is not pinched.

5.10 Cable marking

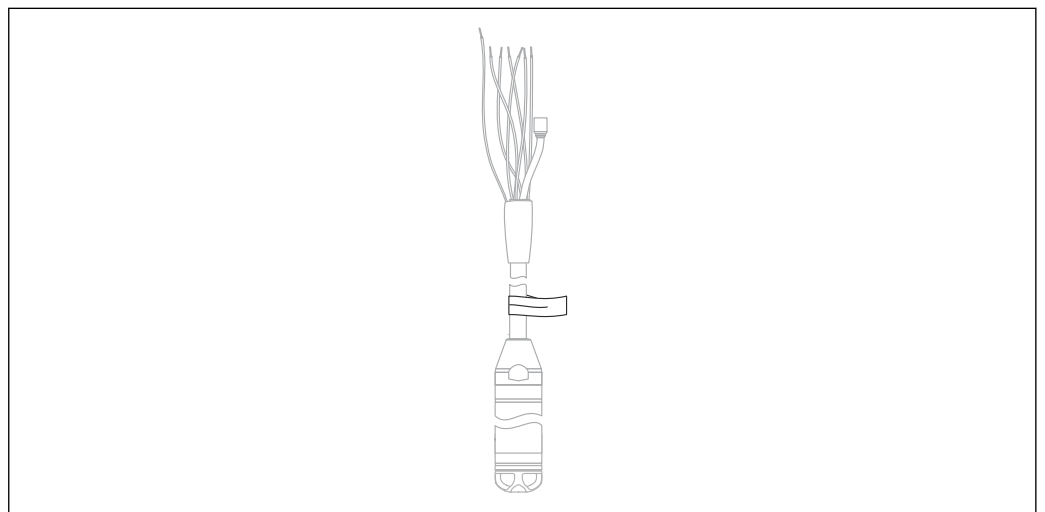

A0030955

- To make installation easier, Endress+Hauser marks the extension cable if a customer-specific length has been ordered.
- Cable marking tolerance (distance to lower end of level probe):
 - Cable length < 5 m (16 ft): ± 17.5 mm (0.69 in)
 - Cable length > 5 m (16 ft): ± 0.2 %
- Material: PET, stick-on label: acrylic
- Temperature resistance: -30 to $+100$ °C (-22 to $+212$ °F)

NOTICE

The marking is used exclusively for installation purposes.

- ▶ The mark must be thoroughly removed without trace in the case of devices with drinking water approval. The extension cable must not be damaged in the process.

 Not for the use of the device in hazardous areas.

5.11 Cable shortening kit

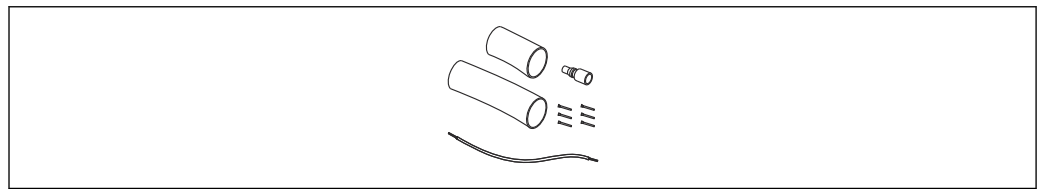

A0030948

The cable shortening kit is used to shorten a cable easily and professionally.

 The cable shortening kit is not designed for the device with FM/CSA approval.

- Ordering information: see Product Configurator
- Associated documentation SD00552P/00/A6.

5.12 Post-mounting check

- Is the device undamaged (visual inspection)?
- Does the device conform to the measuring point specifications?
 - Process temperature
 - Process pressure
 - Ambient temperature
 - Measuring range
- Are the measuring point identification and labeling correct (visual inspection)?
- Check that all screws are firmly seated

6 Electrical connection

⚠ WARNING

Reduced electrical safety due to incorrect connection!

- ▶ When using the measuring instrument in hazardous areas, the applicable national standards and regulations, as well as the safety instructions (XAs) and Installation or Control Drawings (ZDs) must also be observed. All data relating to explosion protection can be found in separate documentation which is available on request. This documentation is supplied with the devices as standard.

6.1 Connecting the device

⚠ WARNING

Reduced electrical safety due to incorrect connection!

- ▶ The supply voltage must match the supply voltage specified on the nameplate
- ▶ Switch off the supply voltage before connecting the device.
- ▶ The cable must end in a dry room or a suitable terminal box. The IP66/IP67 terminal box with GORE-TEX® filter from Endress+Hauser is suitable for outdoor installation. → 19
- ▶ Connect the device in accordance with the following diagrams. Reverse polarity protection is integrated in the device and the temperature head transmitter. Changing the polarities will not result in the destruction of the devices.
- ▶ A suitable circuit breaker should be provided for the device in accordance with IEC/EN 61010.

6.1.1 Device with Pt100

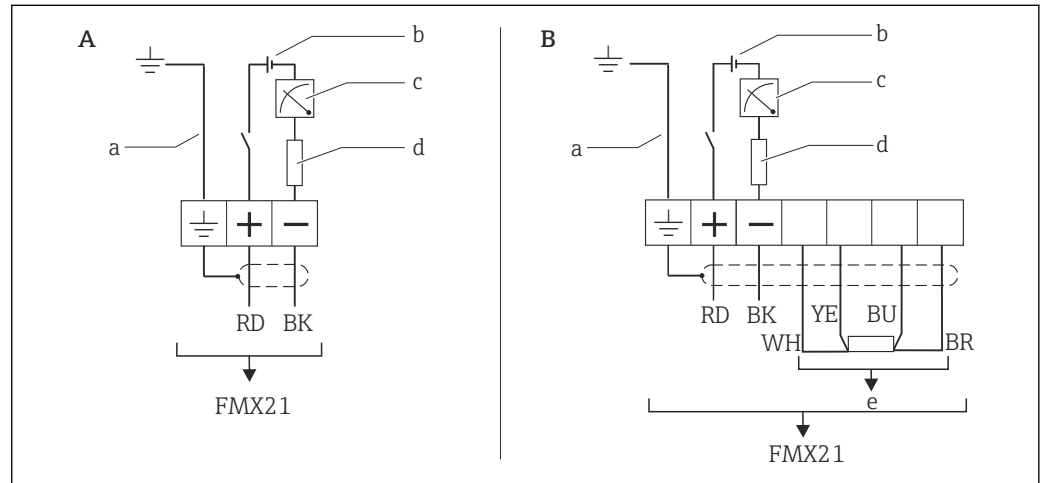

A0019441

- A Device
 B Device with Pt100 (not for use in hazardous areas)
 a Not for devices with external diameter of 29 mm (1.14 in)
 b 10.5 to 30 V_{DC} (hazardous area), 10.5 to 35 V_{DC}
 c 4 to 20 mA
 d Resistance (R_I)
 e Pt100

6.1.2 Device with Pt100 and TMT72 temperature head transmitter

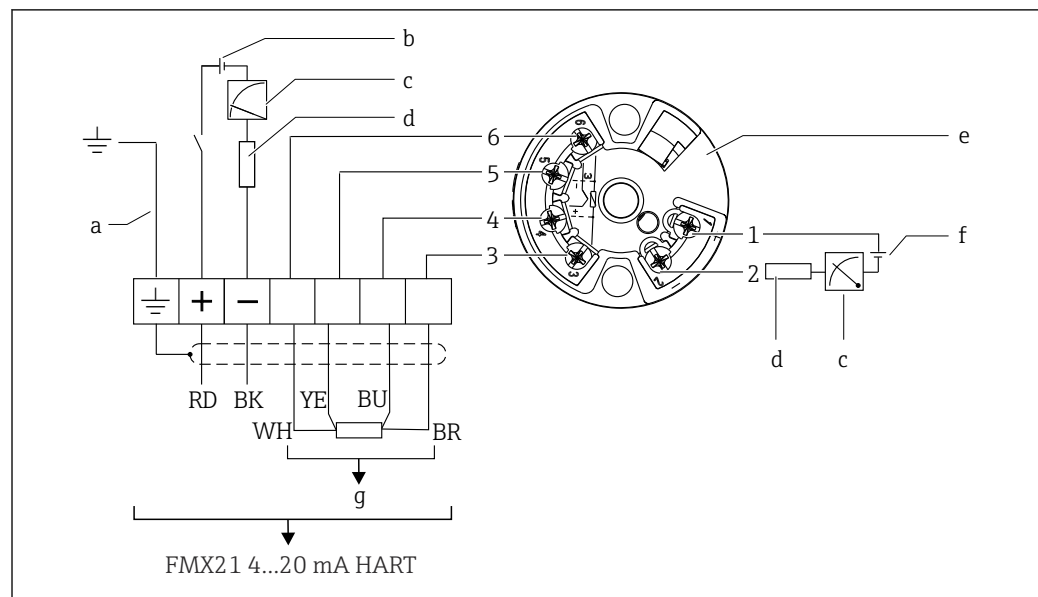

A0018780

- a* Not for devices with external diameter of 29 mm (1.14 in)
- b* 10.5 to 35 V_{DC}
- c* 4 to 20 mA
- d* Resistance (R_L)
- e* TMT72 temperature head transmitter (4 to 20 mA) (not for use in hazardous areas)
- f* 11.5 to 35 V_{DC}
- g* Pt100
- 1...6 Pin assignment

6.1.3 Device with RIA15

i The RIA15 remote display (for Ex or non-Ex area) can be ordered together with the device. See the Product Configurator.

Compensation of the atmospheric pressure must be ensured for the installation. A black, vented cable gland is supplied for this purpose.

i The RIA15 process indicator is loop-powered and does not require any external power supply.

The voltage drop to be taken into account is:

- ≤ 1 V in the standard version with 4 to 20 mA communication
- ≤ 1.9 V with HART communication
- and an additional 2.9 V if display light is used

Without backlighting

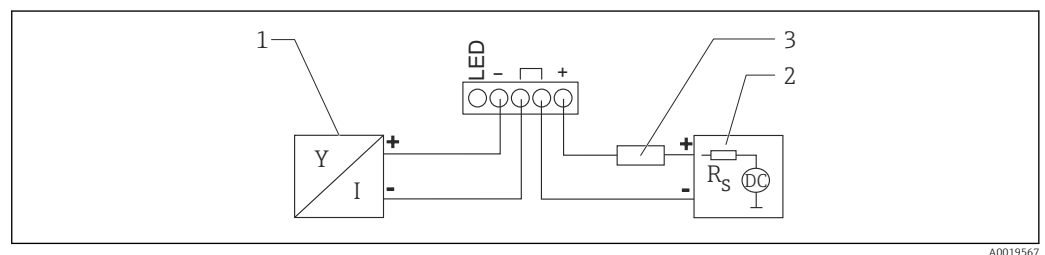

2 Block diagram; connection of the device with HART communication and RIA15 without backlighting

- 1 Device
- 2 Current supply
- 3 HART resistor

With backlighting

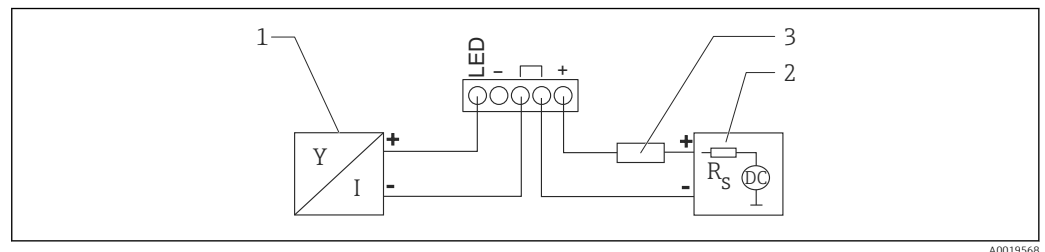

3 Block diagram; connection of the device with HART communication and RIA15 with backlighting

- 1 Device
- 2 Current supply
- 3 HART resistor

6.1.4 Device, RIA15 with installed HART communication resistor module

 The HART communication module for installation in the RIA15 (for Ex or non-Ex areas) can be ordered together with the device.

The **voltage drop** to be taken into account is max. **7 V**

 Compensation of the atmospheric pressure must be ensured for the installation. A black, vented cable gland is supplied for this purpose.

Without backlighting

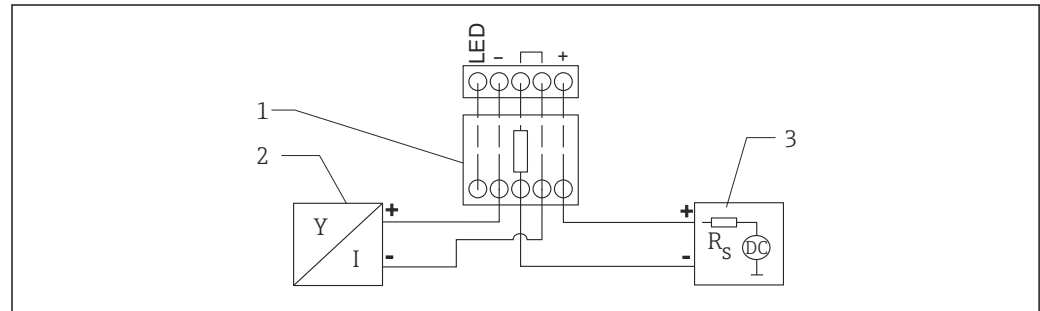

A0020839

 4 Block diagram; device connection, RIA15 without light, HART communication resistor

- 1 HART communication resistance module
- 2 Device
- 3 Current supply

With backlighting

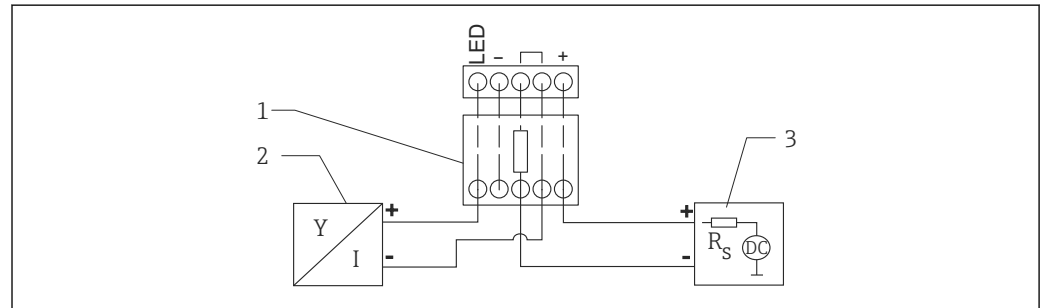

A0020840

 5 Block diagram; device connection, RIA15 with light, HART communication resistor module

- 1 HART communication resistance module
- 2 Device
- 3 Current supply

6.1.5 Wire colors

RD = red, BK = black, WH = white, YE = yellow, BU = blue, BR = brown

6.1.6 Connection data

Connection classification as per IEC 61010-1:

- Overvoltage category 1
- Pollution level 1

Connection data in the hazardous area

See relevant XA.

6.2 Supply voltage

WARNING

Supply voltage might be connected!

Risk of electric shock and/or explosion!

- ▶ When using the measuring device in hazardous areas, installation must comply with the corresponding national standards and regulations as well as the Safety Instructions.
- ▶ All explosion protection data are given in separate Ex documentation, which is available upon request. The Ex documentation is supplied as standard with all devices approved for use in explosion hazardous areas.

6.2.1 Device + Pt100 (optional)

- 10.5 to 35 V (non-hazardous area)
- 10.5 to 30 V (hazardous area)

6.2.2 TMT72 temperature head transmitter (optional)

11.5 to 35 V_{DC}

6.3 Cable specifications

Endress+Hauser recommends using shielded, twisted-pair two-wire cables.

 The probe cables are shielded for device versions with outer diameters of 22 mm (0.87 in) and 42 mm (1.65 in).

6.3.1 Device + Pt100 (optional)

- Commercially available instrument cable
- Terminals, terminal box: 0.08 to 2.5 mm² (28 to 14 AWG)

6.3.2 TMT72 temperature head transmitter (optional)

- Commercially available instrument cable
- Terminals, terminal box: 0.08 to 2.5 mm² (28 to 14 AWG)
- Transmitter connection: max. 1.75 mm² (15 AWG)

6.4 Power consumption

6.4.1 Device + Pt100 (optional)

- ≤ 0.805 W at 35 V_{DC} (non-hazardous area)
- ≤ 0.690 W at 30 V_{DC} (hazardous area)

6.4.2 TMT72 temperature head transmitter (optional)

≤ 0.805 W at 35 V_{DC}

6.5 Current consumption

6.5.1 Device + Pt100 (optional)

Max. current consumption: ≤ 23 mA

Min. current consumption: ≥ 3.6 mA

6.5.2 TMT72 temperature head transmitter (optional)

- Max. current consumption: ≤ 23 mA
- Min. current consumption: ≥ 3.5 mA

6.6 Connecting the measuring unit

6.6.1 Overvoltage protection

To protect the Waterpilot and the TMT72 temperature head transmitter from large interference voltage peaks, Endress+Hauser recommends installing overvoltage protection upstream and downstream of the display and/or evaluation unit as shown in the graphic.

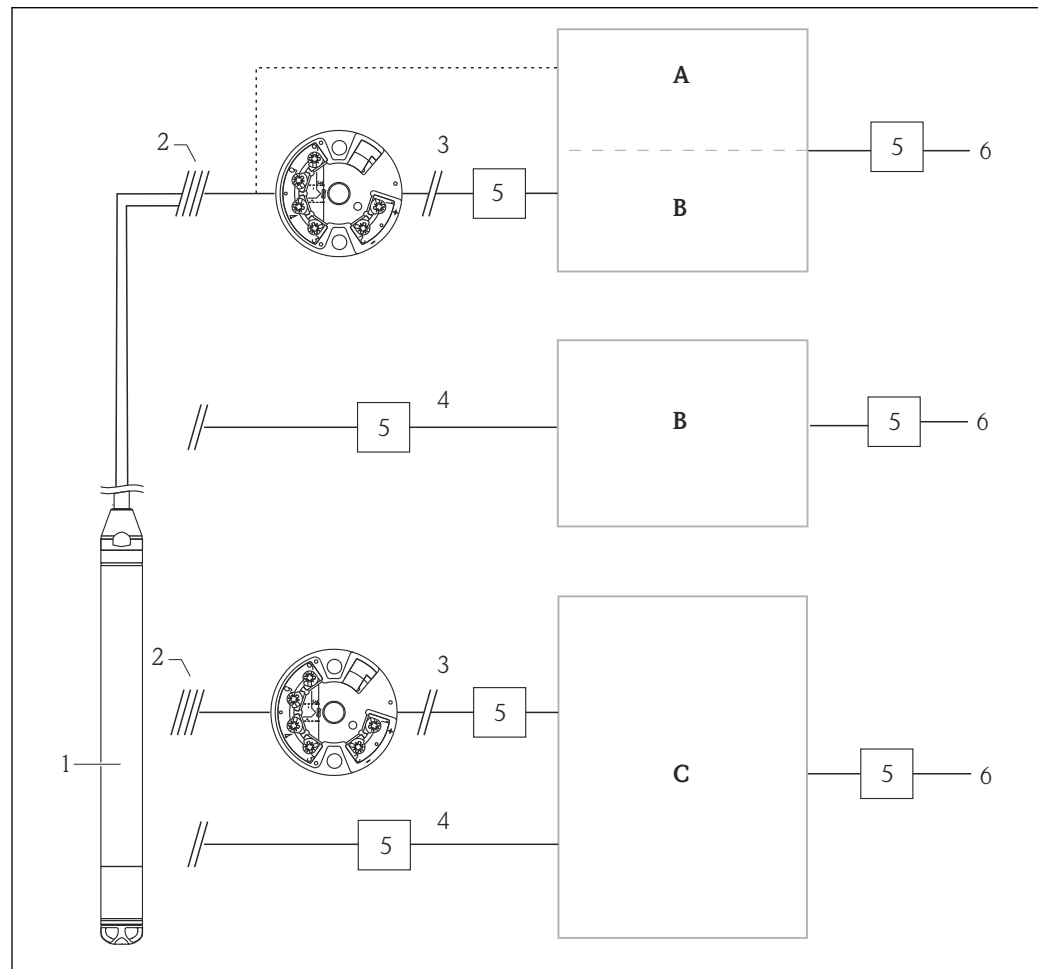

A0018941

- A Power supply, display and evaluation unit with one input for Pt100
 B Power supply, display and evaluation unit with one input for 4 to 20 mA
 C Power supply, display and evaluation unit with two inputs for 4 to 20 mA
 1 Device
 2 Connection for integrated Pt100 in the FMX21
 3 4 to 20 mA HART (temperature)
 4 4 to 20 mA HART (level)
 5 Overvoltage protection, e.g. HAW from Endress+Hauser (not for use in hazardous areas.)
 6 Power supply

i Further information on the TMT72 temperature head transmitter for HART applications from Endress+Hauser can be found in the Technical Information TI01392T.

6.6.2 Connecting the Commubox FXA195

The Commubox FXA195 connects transmitters with the HART protocol to the USB interface of a computer. This enables remote operation of the transmitter using the Endress+Hauser operating program FieldCare/DeviceCare. Power is supplied to the Commubox via the USB port. The Commubox is also suitable for connecting to intrinsically safe circuits. For further information, see the Technical Information TI00404F/00/EN.

6.6.3 Connecting the Field Xpert SFX

Compact, flexible and robust industrial handheld terminal for remote configuration and for obtaining measured values via the HART current output (4 to 20 mA). For details, see Operating Instructions BA00060S/04/EN.

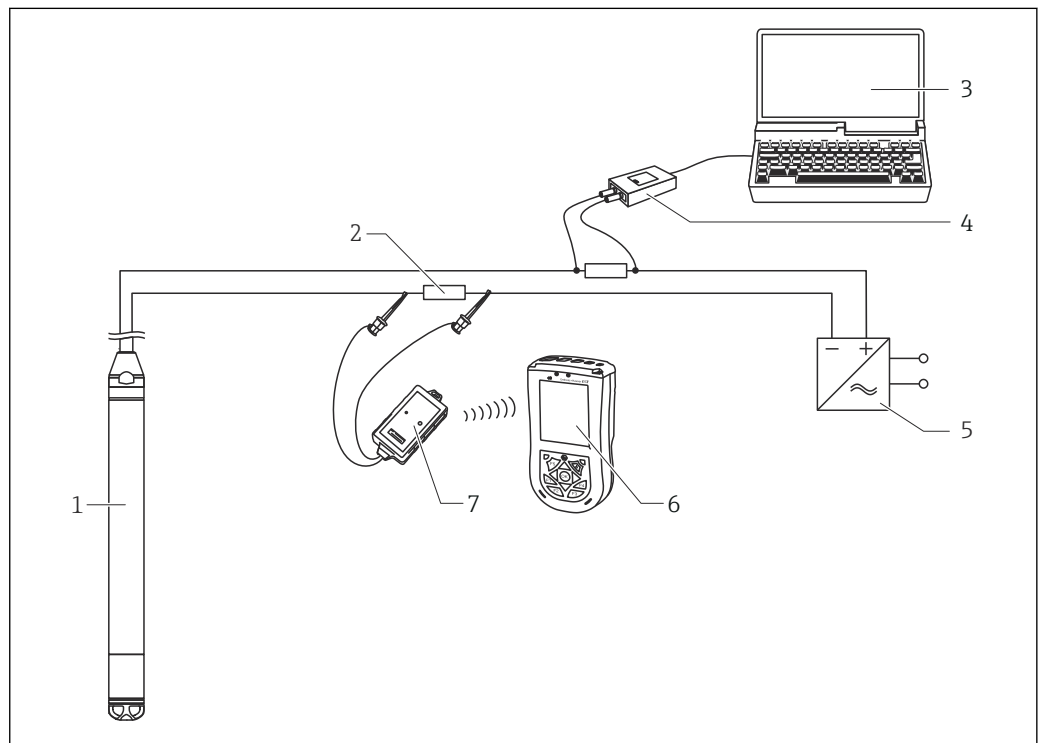

A0018811

- 1 Device
- 2 Required communication resistor $\geq 250 \Omega$
- 3 Computer with operating tool (e.g. FieldCare)
- 4 Commubox FXA195 (USB)
- 5 Transmitter power supply unit, e.g. RN221N (with communication resistor)
- 6 Field Xpert SFX
- 7 VIATOR Bluetooth modem with connecting cable



Only use certified operating devices in hazardous area!

WARNING

Explosion hazard!

- ▶ Do not change the battery of the handheld terminal in the hazardous area.
- ▶ When using the measuring instrument in hazardous areas, the applicable national standards and regulations and the Safety Instructions (XAs) or the Installation or Control Drawings (ZDs) must also be observed.

6.6.4 Connecting for air pressure compensation with external measured value

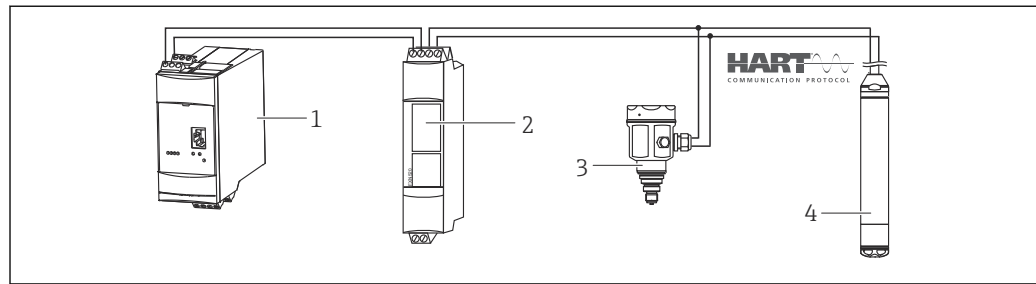

A0018757

- 1 Fieldgate FXA520
- 2 Multidrop Connector FXN520
- 3 Cerabar
- 4 Waterpilot FMX21

For applications in which condensation may occur, the use of an absolute pressure probe is recommended. For level measurement using an absolute pressure probe, the measured value is affected by fluctuations in the atmospheric pressure. To correct the resulting measurement error, you can connect an external absolute pressure sensor (e.g. Cerabar) to the HART signal line, switch the Waterpilot to burst mode and operate the Cerabar in the "Electr. Delta P" mode.

When you switch on the "Electr. Delta P" application, the external absolute pressure sensor calculates the difference between the two pressure signals and can thus determine the level precisely. Only one level measured value can be corrected in this way.

For additional information, see → 53.

If using intrinsically safe devices, the regulations which apply to interconnecting intrinsically safe circuits as outlined in IEC 60079-14 (proof of intrinsic safety) must be observed.

6.6.5 Connecting an external temperature sensor/temperature head transmitter for density compensation

The device can correct measurement errors that result from fluctuations in the density of the water caused by temperature. Users can choose from the following options:

Use the internally measured sensor temperature of the device

The internally measured sensor temperature is calculated in the device for density compensation. The level signal is thus corrected according to the density characteristic line of water.

Use the optional internal Pt100 temperature sensor for density compensation in a suitable HART master (e.g. PLC)

The Waterpilot FMX21 is available with an optional Pt100 temperature sensor. To convert the Pt100 signal to a 4 to 20 mA HART signal, Endress+Hauser also offers the TMT72 temperature head transmitter. The temperature and pressure signal is queried by a HART master (e.g. PLC), where a corrected level value can be generated using a stored linearization table or density function (of a chosen medium).

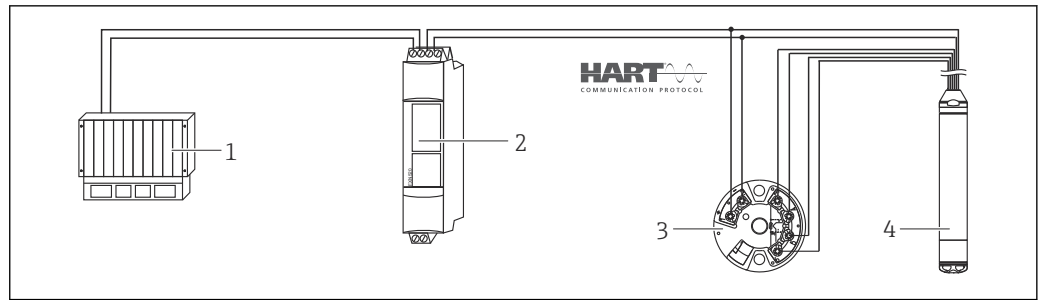

A0018763

- 1 HART master, e.g. PLC (programmable logic controller)
- 2 Multidrop Connector FXN520
- 3 TMT72 temperature head transmitter
- 4 Device

Use an external temperature signal which is transmitted to the FMX21 via HART burst mode

The device is available with an optional Pt100 temperature sensor. With this option, the signal of the Pt100 is evaluated with a HART-compliant temperature head transmitter (min. HART 5.0) that supports the burst mode. The temperature signal can be transmitted to the device in this way. The device uses this signal for density correction of the level signal.

i The TMT72 temperature head transmitter is not suitable for this configuration.

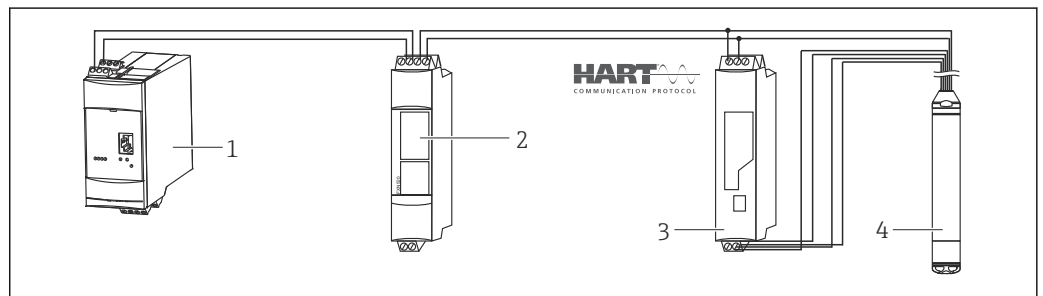

A0018764

- 1 Fieldgate FXA520
- 2 Multidrop Connector FXN520
- 3 HART-compatible temperature transmitter with burst function (e.g. TMT82)
- 4 Device

Without additional compensation due to the anomaly of water, errors of up to 4 % may occur at a temperature of +70 °C (+158 °F), for example. With density compensation, this error is less than 0.5 % in the entire temperature range from 0 to +70 °C (+32 to +158 °F).

For additional information, see → 55.

i For further information on the devices, please refer to the relevant Technical Information:

- TI01010T: temperature transmitter TMT82 (4 to 20 mA HART)
- TI00369F: Fieldgate FXA520
- TI00400F: Multidrop Connector FXN520

6.7 Post-connection check

- Are the device and cables free from damage (visual check)?
- Do the cables used comply with the requirements?
- Are the mounted cables strain-relieved?

- Are all cable glands installed, securely tightened and leak-tight?
- Does the supply voltage match the specifications on the nameplate?
- Is the terminal assignment correct?

7 Operation options

Endress+Hauser offers comprehensive measuring point solutions with display and/or evaluation units for the Waterpilot FMX21 HART and TMT72 temperature head transmitter.

 Your Endress+Hauser service organization would be glad to be of service if you have any other questions. Contact addresses are available at: www.endress.com/worldwide

7.1 Overview of operation options

7.1.1 Operation using Endress+Hauser operating program

FieldCare

The FieldCare operating program is an Endress+Hauser asset management tool based on FDT technology. With FieldCare, you can configure all Endress+Hauser devices as well as devices from other manufacturers that support the FDT standard.

Hardware and software requirements can be found on the Internet:

www.de.endress.com → Search: FieldCare → FieldCare → Technical data.

FieldCare supports the following functions:

- Configuration of transmitters in online/offline mode
- Loading and saving of instrument data (upload/download)
- Documenting the measuring point

Connection options:

- HART via Commubox FXA195 and USB interface of a computer
- HART via Fieldgate FXA520

-  Further information on FieldCare and software download can be found on the internet (www.de.endress.com ® Downloads ® Text Search: FieldCare).
- Connecting the Commubox FXA195
 - As not all internal device dependencies can be mapped in offline operation, the consistency of the parameters must be checked once again before they are transmitted to the device.

DeviceCare

Function scope

Tool for connecting and configuring Endress+Hauser field devices.

The fastest way to configure Endress+Hauser field devices is with the dedicated "DeviceCare" tool. Together with the device type managers (DTMs) it presents a convenient, comprehensive solution.

 For details, see Innovation Brochure IN01047S.

7.1.2 Operation via Field Xpert SFX

Compact, flexible and robust industrial handheld terminal for remote parameterization and for obtaining measured values via the HART current output or FOUNDATION fieldbus. For details, see the Operating Instructions BA00060S/04.

7.1.3 Operation via RIA15

The RIA15 can be used as a local display unit and for the basic configuration of the Waterpilot FMX21 hydrostatic level sensor via HART.

The following parameters can be configured on the FMX21 using the 3 operating keys on the front of the RIA15:

- Pressure engineering unit, level, temperature
- Zero adjustment (only for gauge pressure measuring cells)
- Empty and full pressure adjustment
- Empty and full level calibration
- Reset to factory defaults

Further information on the operating parameters →  63

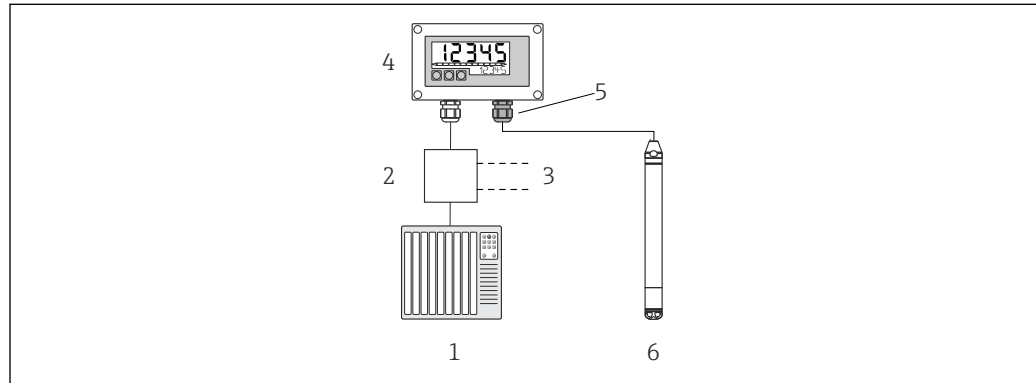

 6 Remote operation of the device via the RIA15

- 1 PLC
- 2 Transmitter power supply, e.g. RN221N (with communication resistor)
- 3 Connection for Commubox FXA195 and Field Communicator 375, 475
- 4 Loop-powered RIA15 process indicator
- 5 Cable gland M16 with pressure compensation membrane
- 6 Device

7.2 Operation concept

Operation with an operating menu is based on an operation concept with "user roles".

■ Operator

Operators are responsible for the devices during normal "operation". This is usually limited to the reading of process values. If the work with the devices goes beyond reading values, it is limited to simple, application-specific functions used in operation. In the event of a fault, these users simply forward the information on the faults but do not intervene themselves.

■ Maintenance

Service engineers usually work with the devices in the phases following device commissioning. Their primary tasks are maintenance and troubleshooting, which require basic settings to be made on the device. Technicians work with the devices over the entire life cycle of the product. Thus, commissioning and advanced settings and configurations are some of the tasks they have to carry out.

■ Expert

Experts work with the devices over the entire life cycle of the device and in some cases have advanced requirements for the devices. Individual parameters/functions from the overall functionality of the devices are required for this purpose time and again. In addition to technical, process-oriented tasks, experts can also perform administrative tasks (e.g. user administration). The "Expert" has access to the entire parameter set.

7.3 Structure of the operating menu

▪ Operator

Submenu: Display/operat.

Contains parameters that are needed to configure the measured value display (selecting the values displayed, display format, etc.). With this submenu, users can change the measured value display without affecting the actual measurement.

▪ Maintenance

Submenu: Setup

Contains all the parameters that are needed to commission measuring operations. This submenu has the following structure:

▪ Standard setup parameters

A wide range of parameters, which can be used to configure a typical application, is available at the start. The measuring mode selected determines which parameters are available. After making settings for all these parameters, the measuring operation should be completely configured in the majority of cases.

▪ "Extended setup" submenu

The "Extended setup" submenu contains additional parameters for more accurate configuration of the measurement, for converting the measured value and for scaling the output signal. This menu is split into additional submenus depending on the measuring mode selected.

▪ Maintenance

Submenu: Diagnostics

Contains all parameters that are needed to detect and analyze operating errors. This submenu has the following structure:

▪ Diagnostic list

Contains up to 10 currently active error messages.

▪ Event logbook

Contains the last 10 error messages (no longer pending).

▪ Instrument info

Contains information for identifying the device.

▪ Measured values

Contains all current measured values.

▪ Simulation

Is used to simulate pressure, level, current and alarm/warning.

▪ Enter reset code

▪ Expert

Submenu: Expert

Contains all the parameters of the device (including those already in one of the other submenus). The "Expert" submenu is structured by the function blocks of the device. It thus contains the following submenus:

▪ System

Contains all device parameters that do not relate to measurement or integration into a control system.

▪ Measurement

Contains all parameters for configuring the measurement.

▪ Output

Contains all parameters for configuring the current output.

▪ Communication

contains all parameters for configuring the HART interface.

▪ Diagnostics



Contains all parameters that are needed to detect and analyze operating errors.

7.4 Locking/unlocking operation



Once you have entered all the parameters, you can lock your entries against unauthorized and undesired access.

The "Operator code" parameter is used to lock/unlock the device.

User code

Navigation	  Setup → Extended setup → User code
Read permission	Operator/Maintenance/Expert
Write permission	Operator/Maintenance/Expert
Description	Use this function to enter a code to lock or unlock operation.
User entry	<ul style="list-style-type: none"> ■ To lock: Enter a number ≠ the release code (value range: 1 to 65535). ■ To unlock: Enter the release code.
Factory setting	0
Note	<p>The release code is "0" in the order configuration. Another release code can be defined in the "Code definition" parameter. If the user has forgotten the release code, the release code can be made visible by entering the number "5864".</p> <p>The release code is defined in the "Code definition" parameter.</p>

Code definition

Navigation	  Setup → Extended setup → Code definition
Read permission	Operator/Maintenance/Expert
Write permission	Operator/Maintenance/Expert
Description	Use this function to enter a release code that can be used to unlock the device.
User entry	A number from 0 to 9999
Factory setting	0
Note	<p>The device setup can also be disabled on the RIA15 via a 4-digit user code. Additional information is available in the RIA15 Operating Instructions BA01170K.</p>

8 Integrating device via HART® protocol

Version data for the device

- Firmware version: 01.00.zz
 - On the title page of the Operating Instructions
 - On the nameplate
 - **Firmware Version** parameter: Diagnosis → Instrument info → Firmware Version
- Manufacturer ID: 17 (0x11)
 - **Manufacturer ID** parameter: Diagnosis → Instrument info → Manufacturer ID
- Device type code: 36 (0x24)
 - **Device ID** parameter: Diagnosis → Instrument info → Device ID
- HART protocol revision: 6.0
 -
- Device revision: 1
 - On the nameplate
 - **Device revision** parameter: Diagnosis → Instrument info → Device revision

The suitable device description file (DD) for the individual operating tools is listed in the table below, along with information on where the file can be acquired.

Operating tools

- FieldCare
 - www.endress.com → Download area
 - CD-ROM (contact Endress+Hauser)
 - DVD (contact Endress+Hauser)
- AMS Device Manager (Emerson Process Management)
 - www.endress.com → Download area
- SIMATIC PDM (Siemens)
 - www.endress.com → Download area
- Field Communicator 375, 475 (Emerson Process Management)
 - Use update function of handheld terminal

8.1 HART process variables and measured values

The following numbers are assigned to the process variables in the factory:

Process variable	Pressure	Level	
		Linear	Table active
First process variable (Primary variable)	0 (Pressure measured)	8 (Level before linearization)	9 (Tank content)
Second process variable (Secondary variable)	2 (Corrected press.)	0 (Pressure measured)	8 (Level before linearization)
Third process variable (Tertiary variable)	3 (Sensor pressure)	2 (Corrected press.)	0 (Pressure measured)
Fourth process variable (Quaternary variable)	4 (Sensor temp.)		

 The assignment of the device variables to the process variable is displayed in the **Expert → Communication → HART output** menu.

The assignment of the device variables to the process variable (SV, TV, QV) can be changed using HART command 51.

An overview of the possible device variables can be found in the following section.

8.2 Device variables and measured values

The following measured values are assigned to the individual device variables:

Device variable code	Device variable	Measured value	Operating mode
0	PRESSURE_1_FINAL_VALUE	Pressure measured	All
1	PRESSURE_1_AFTER_DAMPING	Pressure af. damp	All
2	PRESSURE_1_AFTER_CALIBRATION	Corrected pressure	All
3	PRESSURE_1_AFTER_SENSOR	Corrected pressure	All
4	MEASURED_TEMPERATURE_1	Sensor temp.	All
8	MEASURED_LEVEL_AFTER_SIMULATION	Level before lin.	Only level
9	MEASURED_TANK_CONTENT_AFTER_SIMULATION	Tank content	Only level
10	CORRECTED_MEASUREMENT_DENSITY	Process density	Only level
12	HART_INPUT_VALUE ¹⁾	HART input value	-
251	None (no device variable is mapped)	-	All (but only for quaternary variable)

1) Cannot be selected as an output

 The device variables can be queried by a HART® master using HART® command 9 or 33.

9 Commissioning

NOTICE

If a pressure smaller than the minimum permitted pressure or greater than the maximum permitted pressure is present at the device, the following messages are output in succession:

- ▶ "S140 Working range P" or "F140 Working range P" (depending on the setting in the "Alarm behav. P" parameter)
- ▶ "S841 Sensor range" or "F841 Sensor range" (depending on the setting in the "Alarm behav. P" parameter)
- ▶ "S971 Adjustment" (depending on setting in "Alarm behav. P" parameter)

9.1 Function check

Before commissioning the measuring point, check that the post-installation and post-connection checks have been performed:

-  "Post-mounting check" section
-  "Post-connection check" section

9.2 Unlocking/locking configuration

If the device is locked to prevent configuration, it must first be unlocked.

9.2.1 Locking/unlocking software

If the device is locked via the software (device access code), the key symbol appears in the measured value display. If an attempt is made to write to a parameter, a prompt for the device access code appears. To unlock, enter the user-defined access code.

9.3 Commissioning

Commissioning comprises the following steps:

- Function check
- Selection of the measuring mode and pressure unit
- Position adjustment
- Configuring measurement:
 - Pressure measurement
 - Level measurement

9.4 Selecting the measuring mode

 The device is configured for the "Pressure" measuring mode as standard. The measuring range and the unit in which the measured value is transmitted correspond to the specifications on the nameplate.

WARNING

Changing the measuring mode affects the span (upper range value)

This situation can result in product overflow.

- ▶ If the measuring mode is changed, the setting for the span (upper range value) must be checked in the "Setup" operating menu and readjusted if necessary.

Navigation	 Setup → Measuring mode
Write permission	Operator/Maintenance/Expert
Description	Select the measuring mode. The operating menu is structured differently depending on the measuring mode selected.
Selection	<ul style="list-style-type: none"> ■ Pressure ■ Level
Factory setting	Level

9.5 Selecting the pressure engineering unit

Press. eng. unit

Navigation	 Setup → Press. eng. unit
Write permission	Operator/Maintenance/Expert
Description	Select the pressure engineering unit. If a new pressure engineering unit is selected, all pressure-specific parameters are converted and displayed with the new unit.
Selection	<ul style="list-style-type: none"> ■ mbar, bar ■ mmH₂O, mH₂O, inH₂O ■ ftH₂O ■ Pa, kPa, MPa ■ psi ■ mmHg, inHg ■ kgf/cm²
Factory setting	mbar or bar depending on the nominal measuring range of the sensor module, or as per order specifications.

9.6 Position adjustment

A pressure shift resulting from the orientation of the measuring instrument can be corrected by the position adjustment.

Pos. zero adjust (gauge pressure measuring cell)

Navigation	 Setup → Pos. zero adjust
Write permission	Operator/Maintenance/Expert
Description	Pos. zero adjustment – the pressure difference between zero (set point) and the measured pressure need not be known.

Selection	<ul style="list-style-type: none"> ■ Confirm ■ Cancel
Example	<ul style="list-style-type: none"> ■ Measured value = 2.2 mbar (0.033 psi) ■ You correct the measured value via the "Pos. zero adjust" parameter with the "Confirm" option. This means that you are assigning the value 0.0 to the pressure present. ■ Measured value (after pos. zero adjust) = 0.0 mbar ■ The current value is also corrected.
Factory setting	Cancel



Calib. offset

Write permission	Maintenance/Expert
Description	Position adjustment – the pressure difference between the set point and the measured pressure must be known.
Example	<ul style="list-style-type: none"> ■ Measured value = 982.2 mbar (14.73 psi) ■ You correct the measured value with the value entered, e.g. 2.2 mbar (0.033 psi) via the "Calib. offset" parameter. This means that you are assigning the value 980 mbar (14.7 psi) to the pressure present. ■ Measured value (after pos. zero adjustment) = 980 mbar (14.7 psi) ■ The current value is also corrected.
Factory setting	0,0

9.7 Configuring the damping

The output signal follows measured value changes with the delay time. This can be configured via the operating menu.

Damping

Navigation	  Setup → Damping
Write permission	Operator/Maintenance/Expert (if the "Damping" DIP switch is set to "on")
Description	Enter damping time (time constant τ) ("Damping" DIP switch set to "on") Display damping time (time constant τ) ("Damping" DIP switch set to "off"). The damping affects the speed at which the measured value reacts to changes in pressure.
Input range	0.0 to 999.0 s
Factory setting	2 s or according to order specifications

9.8 Configuring pressure measurement

9.8.1 Calibration with reference pressure (wet calibration)

Example:

In this example, a device with a 400 mbar (6 psi) sensor module is configured for the 0 to +300 mbar (0 to 4.5 psi) measuring range, i.e. 0 mbar and 300 mbar (4.5 psi) are assigned, respectively, to the 4 mA value and the 20 mA value.

Prerequisite:

The pressure values 0 mbar and 300 mbar (4.5 psi) can be specified. The device is already mounted, for example.

i Due to the orientation of the device, there may be pressure shifts in the measured value, i.e. the measured value is not zero in an unpressurized state. For information on how to perform position adjustment, see →  40.

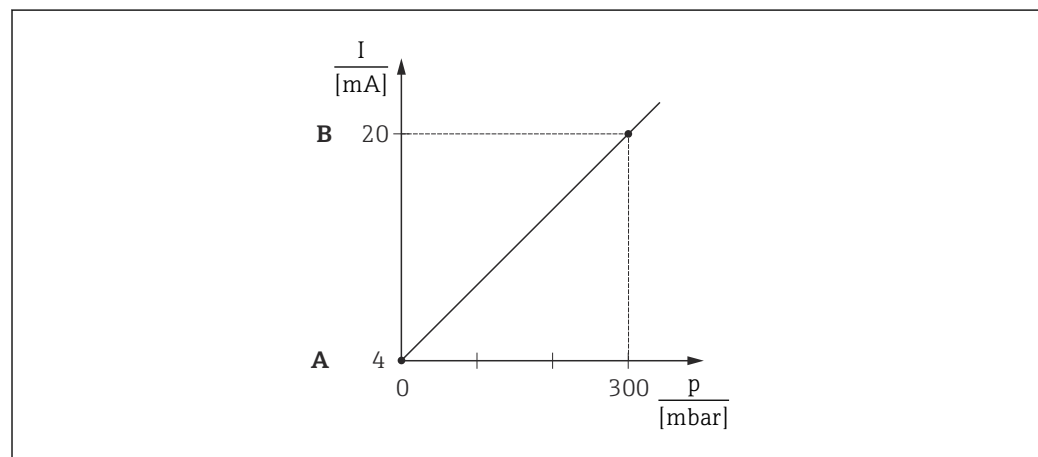

A0031032

A See step 3

B See step 4

1. Select the "Pressure" measuring mode via the "Measuring mode" parameter.
 - ↳ Menu path: Setup → Measuring mode

⚠ WARNING

Changing the measuring mode affects the span (upper range value)

This situation can result in product overflow.

- ▶ If the measuring mode is changed, the setting for the span (upper range value) must be checked in the "Setup" operating menu and readjusted if necessary.

2. Select a pressure unit via the "Press. eng. unit" parameter, here "mbar" for example.
 - ↳ Menu path: Setup → Press. eng. unit
3. The pressure for the LRV (4 mA value) is present at the device, here 0 mbar for example. Select the "Get LRV" parameter. Confirm the value present at the device by selecting "Apply". The pressure value present at the device is assigned to the lower current value (4 mA).
 - ↳ Menu path: Setup → Extended setup → Current output → Get LRV

4. The pressure for the URV (20 mA value) is present at the device, here 300 mbar (4.5 psi) for example. Select the "Get URV" parameter. Confirm the value present at the device by selecting "Apply". The pressure value present at the device is assigned to the upper current value (20 mA).

↳ Menu path: Setup → Extended setup → Current output → Get URV

The measuring range is configured for 0 to +300 mbar (0 to 4.5 psi).

9.8.2 Calibration without reference pressure (dry calibration)

Example:

In this example, a device with a 400 mbar (6 psi) sensor module is configured for the 0 to +300 mbar (0 to 4.5 psi) measuring range, i.e. 0 mbar and 300 mbar (4.5 psi) are assigned, respectively, to the 4 mA value and the 20 mA value.

Prerequisite:

This is a theoretical calibration, i.e. the pressure values for the lower and upper range are known.

- i** Due to the orientation of the device, there may be pressure shifts in the measured value, i.e. the measured value is not zero in an unpressurized state. For information on how to perform position adjustment, see → [40](#).

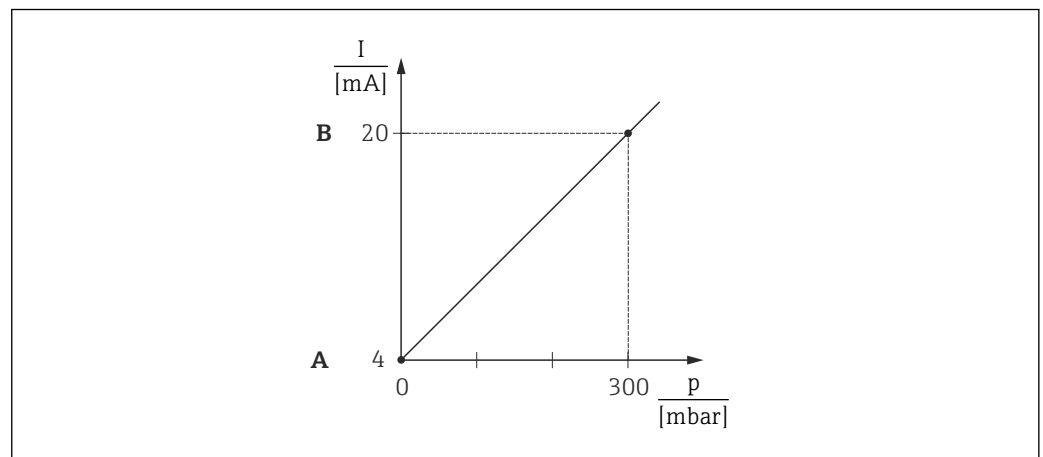

A See step 3

B See step 4

1. Select the "Pressure" measuring mode via the "Measuring mode" parameter.

↳ Menu path: Setup → Measuring mode

⚠ WARNING

Changing the measuring mode affects the span (upper range value)

This situation can result in product overflow.

- ▶ If the measuring mode is changed, the setting for the span (upper range value) must be checked in the "Setup" operating menu and readjusted if necessary.

2. Select a pressure unit via the "Press. eng. unit" parameter, here "mbar" for example.

↳ Menu path: Setup → Press. eng. unit

3. Select the "Set LRV" parameter. Enter the value for the "Set LRV" parameter (here 0 mbar) and confirm. This pressure value is assigned to the lower current value (4 mA).

↳ Menu path: Setup → Extended setup → Current output → Set LRV

4. Select the "Set URV" parameter. Enter the value for the "Set URV" parameter (here 300 mbar (4.5 psi)) and confirm. This pressure value is assigned to the upper current value (20 mA).

↳ Menu path: Setup → Extended setup → Current output → Set URV

The measuring range is configured for 0 to +300 mbar (0 to 4.5 psi).

9.9 Configuring level measurement

9.9.1 Information on level measurement



i You have a choice of two methods for calculating the level: "In pressure" and "In height". The table in the "Overview of level measurement" section that follows provides you with an overview of these two measuring tasks.

- The limit values are not checked, i.e. the values entered must be appropriate for the sensor module and the measuring task for the measuring instrument to be able to measure correctly.
- Customer-specific units are not possible.
- The values entered for "Empty calib./Full calib.", "Empty pressure/Full pressure", "Empty height/Full height" and "Set LRV/Set URV" must be at least 1 % apart. The value will be rejected, and a message displayed, if the values are too close together.

9.9.2 Overview of level measurement



"In pressure" level selection

Calibration is performed by entering two pressure/level value pairs.

- Via the "Output unit" parameter: select %, level, volume or mass units
- Description:
 - Calibration with reference pressure (wet calibration) →  46
 - Calibration without reference pressure (dry calibration) →  44
- The measured value display and the "Level before lin" parameter display the measured value.

"In height" level selection

Calibration is performed by entering the density and two height/level value pairs.

- Via the "Output unit" parameter: select %, level, volume or mass units
- Description:
 - Calibration with reference pressure (wet calibration) →  50
 - Calibration without reference pressure (dry calibration) →  48
- The measured value display and the "Level before lin" parameter display the measured value.

9.9.3 "In pressure" level selection Calibration without reference pressure (dry calibration)

Example:

In this example, the volume in a tank should be measured in liters. The maximum volume of 1000 l (264 gal) corresponds to a pressure of 400 mbar (6 psi).

The minimum volume of 0 liters corresponds to a pressure of 0 mbar since the process membrane of the probe is at the start of the level measuring range.

Prerequisite:

- The measured variable is in direct proportion to the pressure.
- This is a theoretical calibration i.e. the pressure and volume values for the lower and upper calibration point must be known.
- i** ■ The values entered for "Empty calib./Full calib.", "Empty pressure/Full pressure" and "Set LRV/Set URV" must be at least 1% apart. The value will be rejected, and a message displayed, if the values are too close together. Further limit values are not checked, i.e. the values entered must be appropriate for the sensor module and the measuring task for the measuring instrument to be able to measure correctly.
- Due to the orientation of the device, there may be pressure shifts in the measured value, i.e. when the vessel is empty or partly filled, the measured value is not zero. For information on how to perform position adjustment, see → 40.

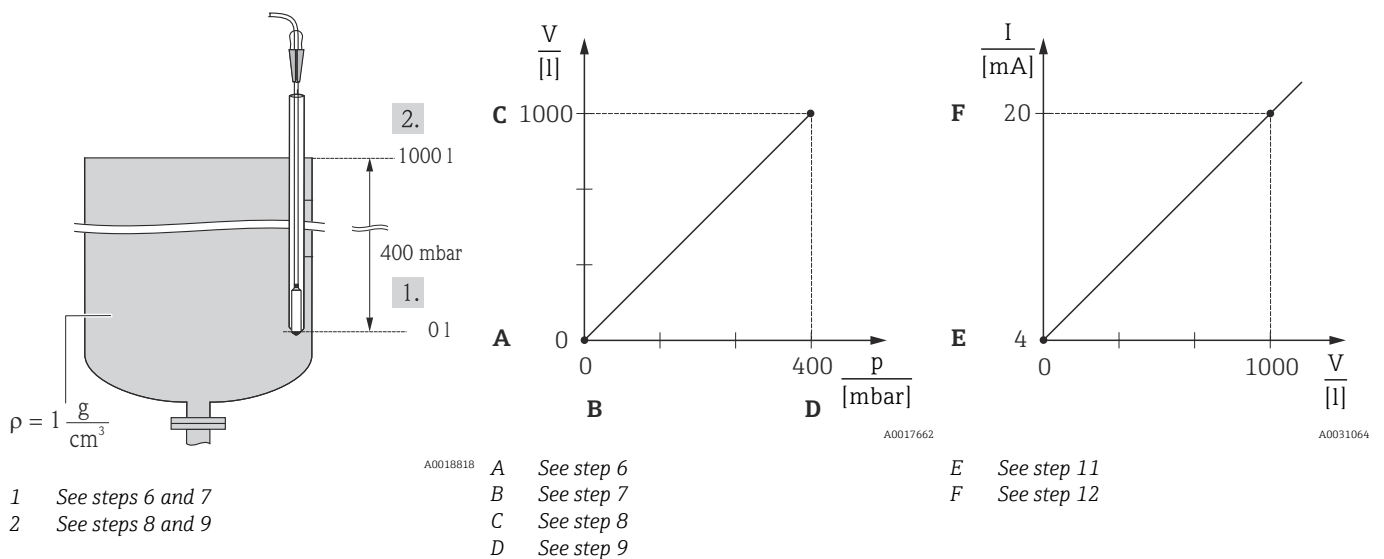

1. Select the "Level" measuring mode via the "Measuring mode" parameter.
↳ Menu path: Setup → Measuring mode

⚠ WARNING**Changing the measuring mode affects the span (upper range value)**

This situation can result in product overflow.

- ▶ If the measuring mode is changed, the setting for the span (upper range value) must be checked in the "Setup" operating menu and readjusted if necessary.

2. Select a pressure unit via the "Press. eng. unit" parameter, here "mbar" for example.
↳ Menu path: Setup → Press. eng. unit
3. Select the "In pressure" level mode via the "Level selection" parameter.
↳ Menu path: Setup → Extended setup → Level → Level selection
4. Select a volume unit via the "Output unit" parameter, here "l" (liters) for example.
↳ Menu path: Setup → Extended setup → Level → Output unit
5. Select the "Dry" option via the "Calibration mode" parameter.
↳ Menu path: Setup → Extended setup → Level → Calibration mode
6. Enter the volume value for the lower calibration point via the "Empty calib." parameter, here 0 liters for example.
↳ Menu path: Setup → Extended setup → Level → Empty calib.
7. Enter the pressure value for the lower calibration point via the "Empty pressure" parameter, here "0 mbar" for example.
↳ Menu path: Setup → Extended setup → Level → Empty pressure

8. Enter the volume value for the upper calibration point via the "Full calib." parameter, here 1 000 l (264 gal) for example.
↳ Menu path: Setup → Extended setup → Level → Full calib.
9. Enter the pressure value for the upper calibration point via the "Full pressure" parameter, here 400 mbar (6 psi) for example.
↳ Menu path: Setup → Extended setup → Level → Full pressure
10. "Adjust density" contains the factory setting 1.0 but can be changed if required. The value pairs subsequently entered must correspond to this density
↳ Menu path: Setup → Extended setup → Level → Adjust density
11. Set the volume value for the lower current value (4 mA) via the "Set LRV" parameter (0 l).
↳ Menu path: Setup → Extended setup → Current output → Set LRV
12. Set the volume value for the upper current value (20 mA) via the "Set URV" parameter (1 000 l (264 gal)).
↳ Menu path: Setup → Extended setup → Current output → Set URV
13. If the process uses a medium other than that on which the calibration was based, the new density must be specified in the "Process density" parameter.
↳ Menu path: Setup → Extended setup → Level → Density → Process density
14. If density correction is required, assign the temperature probe in the "Auto dens. corr." parameter. A density correction is only possible for water. A temperature-density curve that is saved in the device is used. For this reason, the "Adjust density" (step 10) and "Process density" (step 13) parameters are not used here.
↳ Menu path: Expert → Application → Auto dens. corr.

The measuring range is configured for 0 to 1 000 l (0 to 264 gal).

 For this level mode, the measured variables %, level, volume and mass are available, see "Output unit" →  94.

9.9.4 "In pressure" level selection Calibration with reference pressure (wet calibration)

Example:

In this example, the level in a tank should be measured in "m". The maximum level is 3 m (9.8 ft).

The pressure range is derived from the level and the density of the medium. In this situation, the device sets the pressure range to 0 to +300 mbar (0 to 4.5 psi).

Prerequisite:

- The measured variable is in direct proportion to the pressure.
- The tank can be filled and emptied.

 The values entered for "Empty calib./Full calib." and "Set LRV/Set URV" and the pressures present must be at least 1 % apart. The value will be rejected, and a message displayed, if the values are too close together. Other limit values are not checked, i.e. the values entered must be appropriate for the sensor and the measuring task for the device to be able to measure correctly.

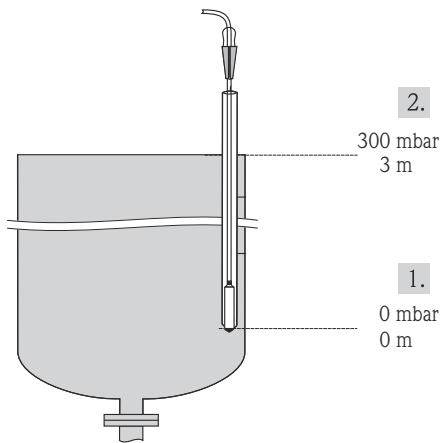

- 1 See step 9
2 See step 10

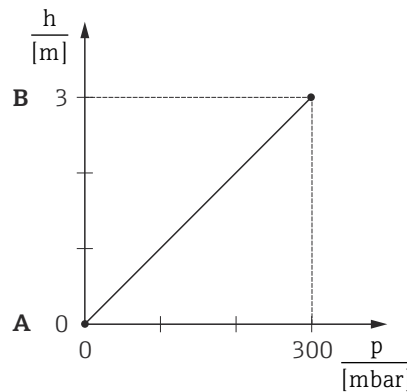

- A0018824 A See step 9
B See step 10

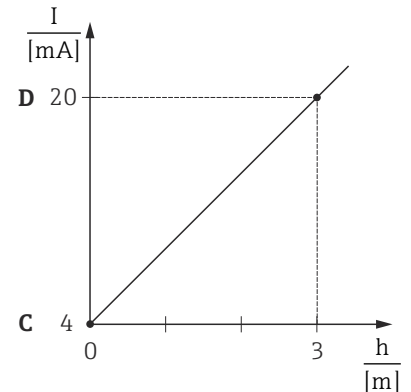

- C See step 11
D See step 12

1. Perform "position adjustment" → 40.
2. Select the "Level" measuring mode via the "Measuring mode" parameter.
↳ Menu path: Setup → Measuring mode

WARNING

Changing the measuring mode affects the span (upper range value)

This situation can result in product overflow.

- ▶ If the measuring mode is changed, the setting for the span (upper range value) must be checked in the "Setup" operating menu and readjusted if necessary.

3. Select a pressure unit via the "Press. eng. unit" parameter, here "mbar" for example.
↳ Menu path: Setup → Press. eng. unit
4. Select the "In pressure" level mode via the "Level selection" parameter.
↳ Menu path: Setup → Extended setup → Level → Level selection.
5. If density correction is required, assign the temperature probe in the "Auto dens. corr." parameter. A density correction is only possible for water. A temperature-density curve that is saved in the device is used. For this reason, the "Adjust density" (step 8) and "Process density" (step 13) parameters are not used here.
↳ Menu path: Expert → Application → Auto dens. corr.
6. Select a level unit via the "Output unit" parameter, here "m" for example.
↳ Menu path: Setup → Extended setup → Level → Output unit
7. Select the "Wet" option via the "Calibration mode" parameter.
↳ Menu path: Setup → Extended setup → Level → Calibration mode
8. If the calibration is performed with a medium other than the process medium, enter the density of the calibration medium in the "Adjust density" parameter.
↳ Menu path: Setup → Extended setup → Level → Adjust density



i The process density can be changed only if automatic density correction is switched off (see step 5).

9. The hydrostatic pressure for the lower calibration point is present at the device, here "0 mbar" for example. Select the "Empty calib." parameter. Enter the level value, here 0 m for example. Confirming the value assigns the applied pressure value to the lower level value.
↳ Menu path: Setup → Extended setup → Level → Empty calib.

10. The hydrostatic pressure for the upper calibration point is present at the device, here 300 mbar (4.35 psi) for example. Select the "Full calib." parameter. Enter the level value, here 3 m (9.8 ft) for example. Confirming the value assigns the applied pressure value to the upper level value.
 - ↳ Menu path: Setup → Extended setup → Level → Full calib.
11. Use the "Set LRV" parameter to set the level value for the lower current value (4 mA), here "0 m" for example.
 - ↳ Menu path: Setup → Extended setup → Current output → Set LRV
12. Use the "Set URV" parameter to set the level value for the upper current value (20 mA) (3 m (9.8 ft)).
 - ↳ Menu path: Setup → Extended setup → Current output → Set URV
13. If the process uses a medium other than that on which the calibration was based, the new density must be specified in the "Process density" parameter.
 - ↳ Menu path: Setup → Extended setup → Level → Process density.

 The process density can be changed only if automatic density correction is switched off (see step 5).

The measuring range is configured for 0 to 3 m (0 to 9.8 ft).



 For this level mode, the measured variables %, level, volume and mass are available, see "Output unit" →  94.

9.9.5 "In height" level selection Calibration without reference pressure (dry calibration)

Example:

In this example, the volume in a tank should be measured in liters. The maximum volume of 1000 l (264 gal) corresponds to a level of 4 m (13 ft). The minimum volume of 0 liters corresponds to a level of 0 m since the process membrane of the probe is at the start of the level measuring range.

Prerequisite:

- The measured variable is in direct proportion to the pressure.
 - This is a theoretical calibration i.e. the height and volume values for the lower and upper calibration point must be known.
-  ▪ The values entered for "Empty calib./Full calib.", "Empty height/Full height" and "Set LRV/Set URV" must be at least 1% apart. The value will be rejected, and a message displayed, if the values are too close together. Other limit values are not checked, i.e. the values entered must be appropriate for the sensor and the measuring task for the device to be able to measure correctly.
- Due to the orientation of the device, there may be pressure shifts in the measured value, i.e. when the vessel is empty or partly filled, the measured value is not zero. For information on how to perform position adjustment, see →  40.

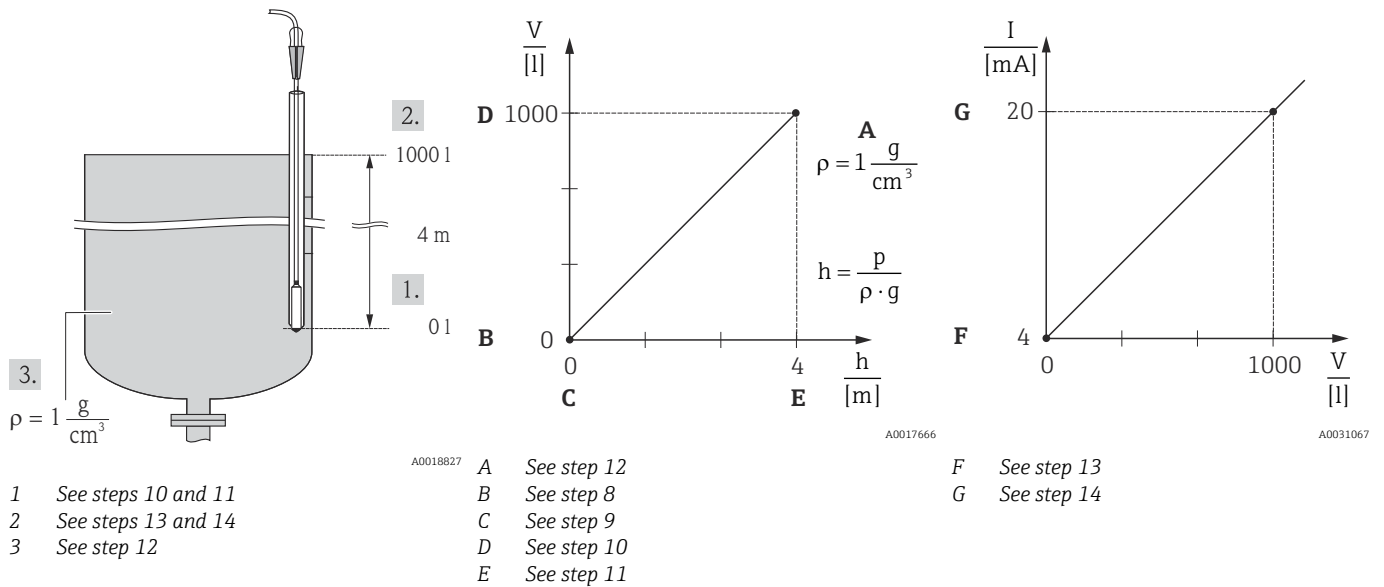

- 1 See steps 10 and 11
- 2 See steps 13 and 14
- 3 See step 12

1. Select the "Level" measuring mode via the "Measuring mode" parameter.
 ↳ Menu path: Setup → Measuring mode

⚠ WARNING

Changing the measuring mode affects the span (upper range value)



This situation can result in product overflow.

- ▶ If the measuring mode is changed, the setting for the span (upper range value) must be checked in the "Setup" operating menu and readjusted if necessary.

2. Select a pressure unit via the "Press. eng. unit" parameter, here "mbar" for example.
 ↳ Menu path: Setup → Press. eng. unit
3. Select the "In height" level mode via the "Level selection" parameter.
 ↳ Menu path: Setup → Extended setup → Level → Level selection.
4. If density correction is required, assign the temperature probe in the "Auto dens. corr." parameter.
 ↳ Menu path: Setup → Extended setup → Level → Level selection.
5. Select a volume unit via the "Output unit" parameter, here "l" (liters) for example. A density correction is only possible for water. A temperature-density curve that is saved in the device is used. For this reason, the "Adjust density" (step 12) and "Process density" (step 15) parameters are not used here.
 ↳ Menu path: Setup → Extended setup → Level → Output unit
6. Select a volume unit via the "Output unit" parameter, here "l" (liters) for example.
 ↳ Menu path: Setup → Extended setup → Level → Output unit
7. Select a level unit via the "Height unit" parameter, here "m" for example.
 ↳ Menu path: Setup → Extended setup → Level → Height unit
8. Select the "Dry" option via the "Calibration mode" parameter.
 ↳ Menu path: Setup → Extended setup → Level → Calibration mode
9. Enter the volume value for the lower calibration point via the "Empty calib." parameter, here 0 liters for example.
 ↳ Menu path: Setup → Extended setup → Level → Empty calib.
10. Enter the height value for the lower calibration point via the "Empty height" parameter, here 0 m for example.
 ↳ Menu path: Setup → Extended setup → Level → Empty height

11. Enter the volume value for the upper calibration point via the "Full calib." parameter, here 1 000 l (264 gal) for example.
↳ Menu path: Setup → Extended setup → Level → Full calib.
 12. Enter the height value for the upper calibration point via the "Full height" parameter, here 4 m (13 ft) for example.
↳ Menu path: Setup → Extended setup → Level → Full height
 13. Enter the density of the medium via the "Adjust density" parameter, here "1 g/cm³" (1 SGU) for example.
↳ Menu path: Setup → Extended setup → Level → Adjust density
 14. Set the volume value for the lower current value (4 mA) via the "Set LRV" parameter (0 l).
↳ Menu path: Setup → Extended setup → Current output → Set LRV
 15. Set the volume value for the upper current value (20 mA) via the "Set URV" parameter (1 000 l (264 gal)).
↳ Menu path: Setup → Extended setup → Current output → Set URV
 16. If the process uses a medium other than that on which the calibration was based, the new density must be specified in the "Process density" parameter.
↳ Menu path: Setup → Extended setup → Level → Process density
-  The process density can only be changed if automatic density correction is switched off (see Step 4).

The measuring range is configured for 0 to 1 000 l (0 to 264 gal).

 For this level mode, the measured variables %, level, volume and mass are available; see "Output unit" →  94.

9.9.6 "In height" level selection Calibration with reference pressure (wet calibration)

Example:

In this example, the volume in a tank should be measured in liters. The maximum volume of 1 000 l (264 gal) corresponds to a level of 4 m (13 ft).

The minimum volume of 0 liters corresponds to a level of 0 m since the process membrane of the probe is at the start of the level measuring range. The density of the medium is 1 g/cm³ (1 SGU).

Prerequisite:

- The measured variable is in direct proportion to the pressure.
- The tank can be filled and emptied.

 The values entered for "Empty calib./Full calib." and "Set LRV/Set URV" and the pressures present must be at least 1% apart. The value will be rejected, and a message displayed, if the values are too close together. Other limit values are not checked, i.e. the values entered must be appropriate for the sensor and the measuring task for the device to be able to measure correctly.

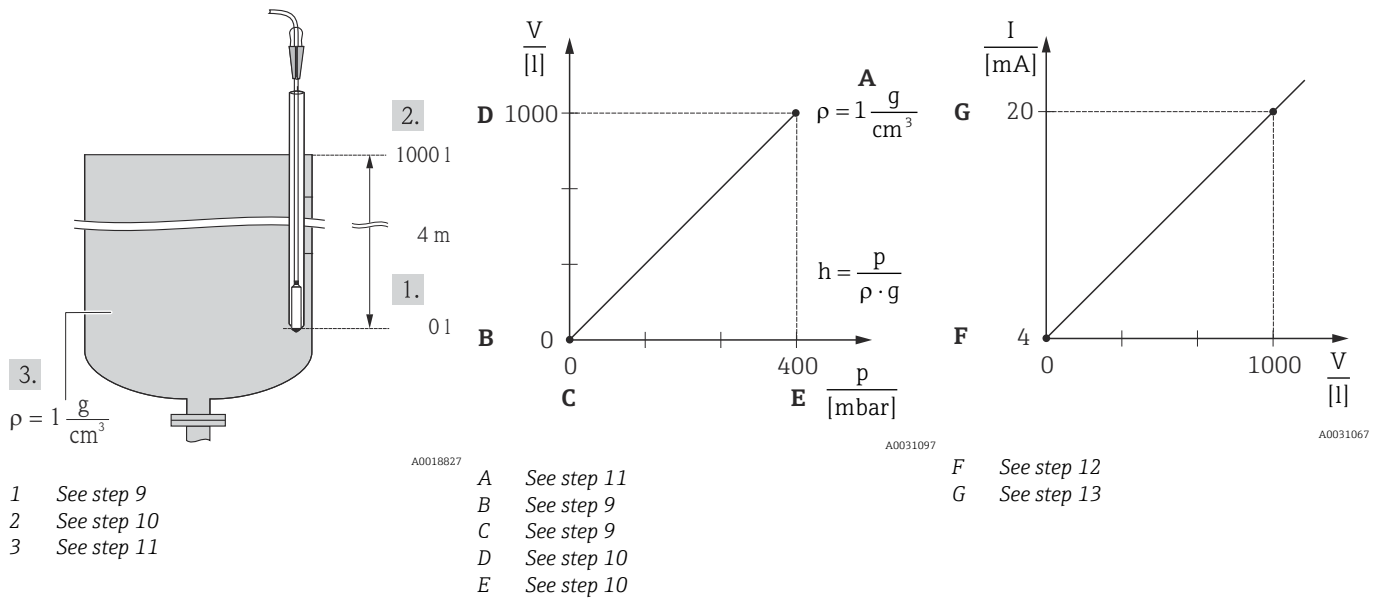

1. Perform "position adjustment" → 40.
2. Select the "Level" measuring mode via the "Measuring mode" parameter.
 - ↳ Menu path: Setup → Measuring mode



⚠ WARNING

Changing the measuring mode affects the span (upper range value)



This situation can result in product overflow.

- ▶ If the measuring mode is changed, the setting for the span (upper range value) must be checked in the "Setup" operating menu and readjusted if necessary.

3. Select the "In height" level mode via the "Level selection" parameter.
 - ↳ Menu path: Setup → Extended setup → Level → Level selection.
4. If density correction is required, assign the temperature probe in the "Auto dens. corr." parameter. A density correction is only possible for water. A temperature-density curve that is saved in the device is used. For this reason, the "Adjust density" (step 11) and "Process density" (step 14) parameters are not used here.
 - ↳ Menu path: Expert → Application → Auto dens. corr.
5. Select a pressure unit via the "Press. eng. unit" parameter, here "mbar" for example.
 - ↳ Menu path: Setup → Press. eng. unit
6. Select a volume unit via the "Output unit" parameter, here "l" (liters) for example.
 - ↳ Menu path: Setup → Extended setup → Level → Output unit
7. Select a height unit via the "Height unit" parameter, here "m" for example.
 - ↳ Menu path: Setup → Extended setup → Level → Height unit
8. Select the "Wet" option via the "Calibration mode" parameter.
 - ↳ Menu path: Setup → Extended setup → Level → Calibration mode
9. The hydrostatic pressure for the lower calibration point is present at the device, here "0 mbar" for example. Enter the volume value for the lower calibration point via the "Empty calib." parameter, here "0 liters" for example.
 - ↳ Menu path: Setup → Extended setup → Level → Empty calib.
10. The hydrostatic pressure for the upper calibration point is present at the device, here "400 mbar (6 psi)" for example. Enter the volume value for the upper calibration point via the "Full calib." parameter, here 1000 l (264 gal) for example.
 - ↳ Menu path: Setup → Extended setup → Level → Full calib.

11. If the calibration is performed with a medium other than the process medium, enter the density of the calibration medium in the "Adjust density" parameter. Here 1 g/cm³ (1 SGU), for example.
↳ Menu path: Setup → Extended setup → Level → Adjust density
-  The process density can only be changed if automatic density correction is switched off (see Step 4).
12. Set the volume value for the lower current value (4 mA) via the "Set LRV" parameter (0 l).
↳ Menu path: Setup → Extended setup → Current output → Set LRV
13. Set the volume value for the upper current value (20 mA) via the "Set URV" parameter (1 000 l (264 gal)).
↳ Menu path: Setup → Extended setup → Current output → Set URV
14. If the process uses a medium other than that on which the calibration was based, the new density must be specified in the "Process density" parameter.
↳ Menu path: Setup → Extended setup → Level → Process density.
-  The process density can only be changed if automatic density correction is switched off (see Step 4).

The measuring range is configured for 0 to 1 000 l (0 to 264 gal).

-  For this level mode, the measured variables %, level, volume and mass are available, see "Output unit" →  94.

9.9.7 Calibration with partially filled vessel (wet calibration)

Example:

This example describes a wet calibration for situations in which it is not possible to empty the vessel and then fill it to 100 %.

During this wet calibration, a level of 20 % is used as the calibration point for "Empty" and a level of "25 %" is used as the calibration point for "Full".

The calibration is then extended to 0 to 100 % and the lower range value (LRV)/upper range value (URV) are adapted accordingly.

Prerequisite:

- The default value in level mode for the calibration mode is "Wet".
- This value can be configured: Menu path: Setup → Extended setup → Level → Calibration mode

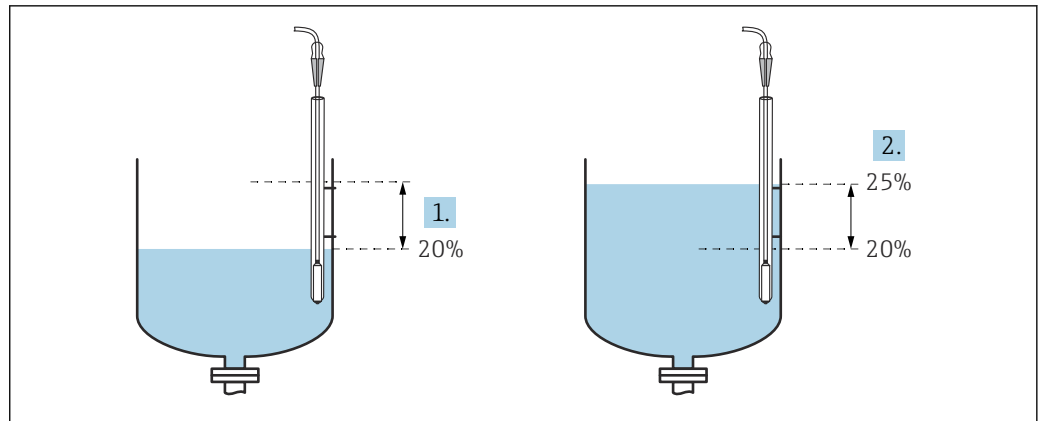

A0018841

- 1 See step 2
- 2 See step 3

1. Select the "Level" measuring mode via the "Measuring mode" parameter.
↳ Menu path: Setup → Measuring mode

⚠ WARNING

Changing the measuring mode affects the span (upper range value)

This situation can result in product overflow.

- ▶ If the measuring mode is changed, the setting for the span (upper range value) must be checked in the "Setup" operating menu and readjusted if necessary.

2. Set the value for "Empty calib." with the differential pressure for the level, e.g. 20 %
↳ Menu path: Setup → Extended setup → Level → Empty calib.
3. Set the value for "Full calib." with the differential pressure for the level, e.g. 25 %
↳ Menu path: Setup → Extended setup → Level → Full calib.
4. The values for the pressure when the vessel is full or empty are measured automatically during adjustment. The transmitter automatically sets the pressure values that are most suitable for "Empty calib." and "Full calib." as the minimum and maximum pressure which generates the output current. For this reason, the correct upper range value (URV) and the correct lower range value (LRV) must be set.

i If the process uses a medium other than that on which the calibration was based, the new density must be specified in the "Process density" parameter. In this case, you must enter the various densities via the following menu path:

- Setup → Extended setup → Level → Adjust density (034) (e.g. 1.0 kg/11.0 kg/l for water)
- Setup → Extended setup → Level → Process density (035) (e.g. 0.8 kg/l for oil)

9.9.8 Level measurement with absolute pressure probe and external pressure signal (electrical differential pressure)

Example:

In this example, a Waterpilot FMX21 and a Cerabar M (each with an absolute pressure measuring cell) are connected via the common communication bus. The level can thus be measured in a deep well, with simultaneous compensation for the effect of atmospheric pressure.

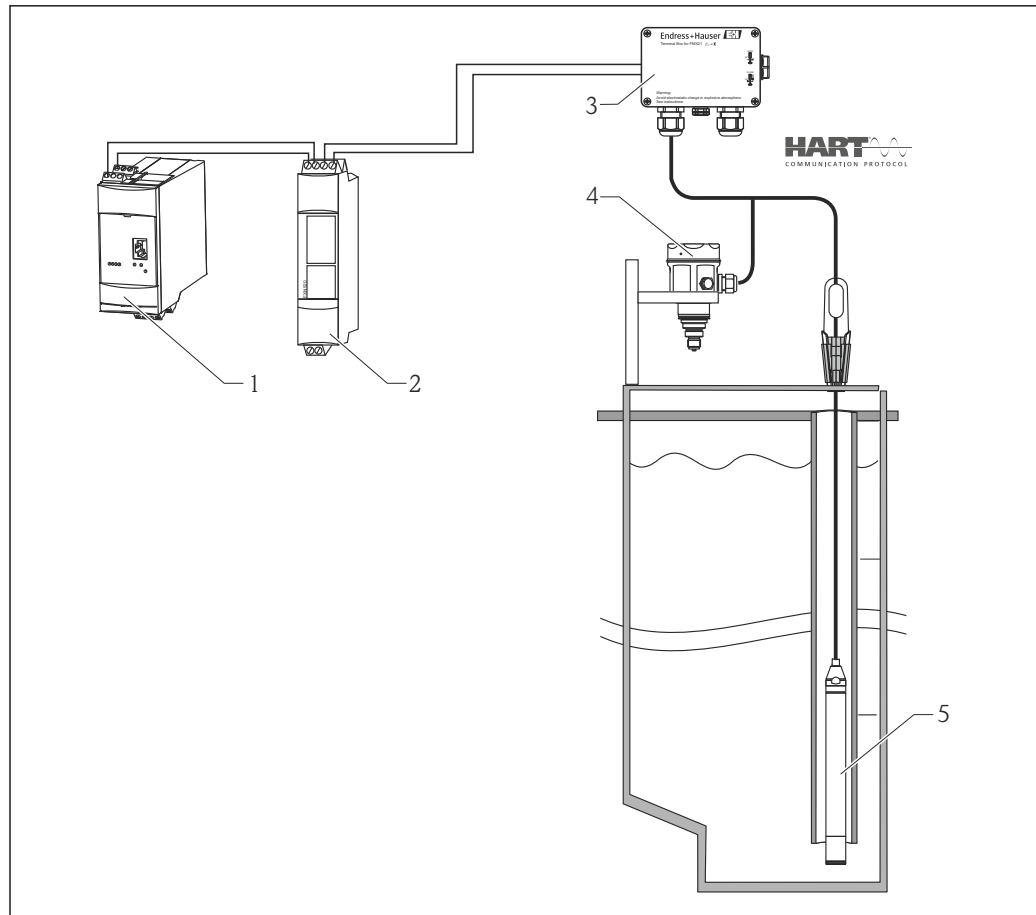

A0018821

- 1 Fieldgate FXA520
- 2 Multidrop Connector FXN520
- 3 Terminal box (can be ordered as an accessory)
- 4 Cerabar M absolute pressure (level)
- 5 Waterpilot absolute pressure (pressure)

Sensor level adjustment (Waterpilot)

1. Select the "Pressure" measuring mode via the "Measuring mode" parameter.
↳ Menu path: Setup → Measuring mode

⚠ WARNING

Changing the measuring mode affects the span (upper range value)

This situation can result in product overflow.

- ▶ If the measuring mode is changed, the setting for the span (upper range value) must be checked in the "Setup" operating menu and readjusted if necessary.

2. Select a pressure unit via the "Press. eng. unit" parameter, here "mbar" for example.
↳ Menu path: Setup → Press. eng. unit
3. The sensor is unpressurized; perform a position adjustment → 40
4. Switch on the burst mode via the "Burst mode" parameter.
↳ Menu path: Expert → Communication → HART config
5. Set the output current to "Fixed" 4 mA via the "Current mode" parameter.
↳ Menu path: Expert → Communication → HART config
6. Via the "Bus address" parameter, set an address that is not equal to "0", e.g. the bus address = 1. (HART 5.0 master: range 0 to 15, where address = "0" calls up the "Signaling" setting; HART 6.0 master: range 0 to 63)
↳ Menu path: Expert → Communication → HART config

Sensor level adjustment (Cerabar)

1. Select the "Level" measuring mode via the "Measuring mode" parameter.
 - ↳ Menu path: Setup → Measuring mode

⚠ WARNING

Changing the measuring mode affects the span (upper range value)

This situation can result in product overflow.

- ▶ If the measuring mode is changed, the setting for the span (upper range value) must be checked in the "Setup" operating menu and readjusted if necessary.

2. Select a pressure unit via the "Press. eng. unit" parameter, here "mbar" for example.
 - ↳ Menu path: Setup → Press. eng. unit
3. The sensor is unpressurized; perform a position adjustment → 📄 40
4. Set the output current to "Fixed" 4 mA via the "Current mode" parameter.
 - ↳ Menu path: Expert → Communication → HART config
5. Via the "Bus address" parameter, set an address that is not equal to "0", e.g. the bus address = 2. (HART 5.0 master: range 0 to 15, where address = "0" calls up the "Signaling" setting; HART 6.0 master: range 0 to 63)
 - ↳ Menu path: Expert → Communication → HART config
6. Activate the reading of a value sent externally in burst mode via the "Electr. Delta P" parameter.
 - ↳ Menu path: Expert → Application
7. Perform level calibration (wet or dry)

Result: The measured value output by the atmospheric pressure sensor equals the level in the deep well (differential signal) and can be read out by means of a HART request for the address of the atmospheric pressure sensor.

- It is not permitted to reverse the assignment of the measuring points to the direction of communication.
- The measured value of the transmitting device (via burst) must always be greater than the measured value of the receiving device (via "Electr. Delta P" mode).
- Adjustments that involve an offset in the pressure values (e.g. position adjustment, trim) must always suit the individual sensor and the sensor's orientation irrespective of the "Electr. Delta P" application.
- Other settings result in non-permitted use of the "Electr. Delta P" mode and can lead to incorrect measured values.

9.10 Automatic density compensation

9.10.1 Automatic density compensation with the internally measured sensor temperature

Example:

In this example, the device is used for level measurement in water. The change in the water density caused by changing temperatures is automatically factored into the level signal by activating the automatic density compensation.

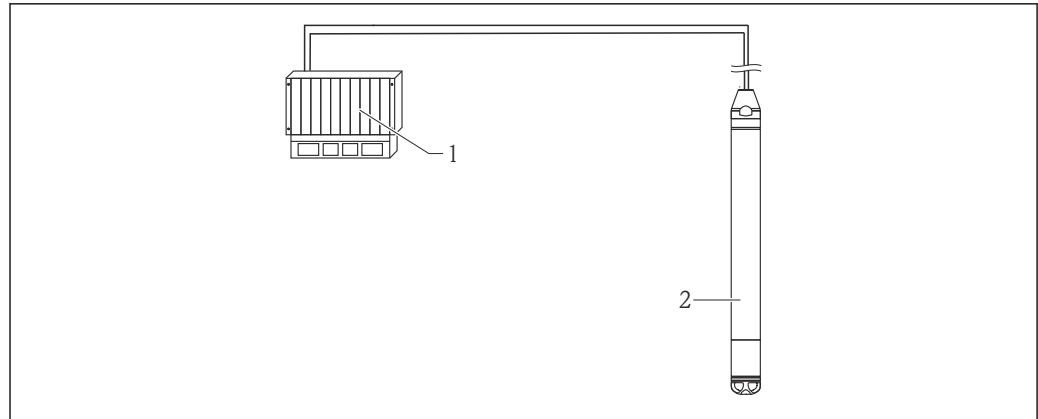

A0018822

- 1 HART master, e.g. PLC (programmable logic controller)
 2 Device

Device adjustment for level measurement

1. Select the "Level" measuring mode via the "Measuring mode" parameter.
 ↳ Menu path: Setup → Measuring mode

⚠ WARNING

Changing the measuring mode affects the span (upper range value)

This situation can result in product overflow.

- ▶ If the measuring mode is changed, the setting for the span (upper range value) must be checked in the "Setup" operating menu and readjusted if necessary.

2. Select a pressure unit via the "Press. eng. unit" parameter, here "mbar" for example.
 ↳ Menu path: Setup → Press. eng. unit
3. The sensor is unpressurized; perform a position adjustment → 📄 40
4. Set the "Auto dens. corr." parameter to Sensor temperature.
 ↳ Menu path: Expert → Application
5. Perform level calibration (wet or dry)

The measured value output by the device corresponds to the level in the deep well corrected by means of the density characteristic line of water.

9.10.2 Automatic density compensation using an integrated Pt100 for calculation in a suitable HART master (e.g. PLC)

Example:

In this example, the device with an integrated Pt100 is connected via the common communication bus to any temperature head transmitter with HART communication (e.g. TMT72). The temperature and pressure signal is transmitted to the HART master (e.g. PLC), where a corrected level value can be generated using a stored linearization table or density function (of a chosen medium). A pressure signal and a temperature signal can thus be generated with a chosen density function to compensate for a level.

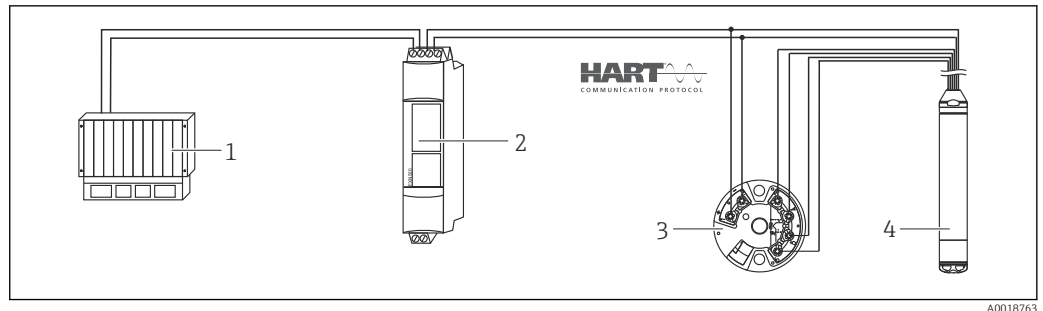

- 1 HART master, PLC (programmable logic controller)
- 2 Multidrop Connector FXN520
- 3 TMT72 temperature head transmitter
- 4 Device

Device adjustment for level measurement

1. Select the "Level" measuring mode via the "Measuring mode" parameter.
 - ↳ Menu path: Setup → Measuring mode

WARNING

Changing the measuring mode affects the span (upper range value)

This situation can result in product overflow.

- ▶ If the measuring mode is changed, the setting for the span (upper range value) must be checked in the "Setup" operating menu and readjusted if necessary.
2. Select a pressure unit via the "Press. eng. unit" parameter, here "mbar" for example.
 - ↳ Menu path: Setup → Press. eng. unit
 3. The sensor is unpressurized; perform a position adjustment →  40
 4. Set the output current to "Fixed" 4 mA via the "Current mode" parameter.
 - ↳ Menu path: Expert → Communication → HART config
 5. Perform level calibration (wet or dry)
 6. Via the "Bus address" parameter, set an address that is not equal to "0", e.g. the bus address = 1. (HART 5.0 master: range 0 to 15, where address = "0" calls up the "Signaling" setting; HART 6.0 master: range 0 to 63)
 - ↳ Menu path: Expert → Communication → HART config

 The output current of the temperature head transmitter used must also be set to "Fixed" and have a HART address other than zero (e.g. address = 2).

- ▶ Switch on the burst mode via the "Burst mode" parameter.
 - ↳ Menu path: Expert → Communication → HART config

By balancing the pressure signal and temperature signal in a suitable HART master (e.g. PLC), a corrected level value can be determined for any medium by using a suitable density function.

9.10.3 Automatic density compensation using an external temperature signal for calculation in the device

Example:

In this example, the device with an integrated Pt100 is connected to a HART-compliant temperature transmitter via the common communication bus. With this option, the signal of the Pt100 is evaluated with a HART-compliant temperature head transmitter (min. HART 5.0) that supports the burst mode. The change in the water density caused by changing temperatures is automatically factored into the level signal by activating the automatic density compensation.

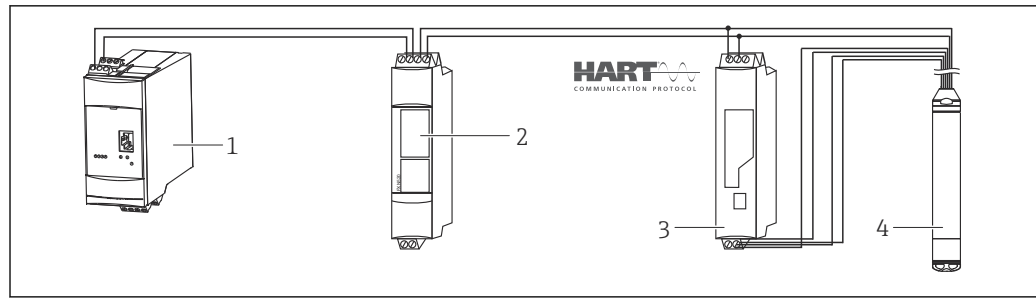

A0018764

- 1 Fieldgate FXA520
- 2 Multidrop Connector FXN520
- 3 HART-compatible temperature transmitter (e.g. TMT82)
- 4 Device

Configuring the HART-compliant temperature head transmitter (min. HART 5.0) with burst function

The output current of the temperature transmitter used should be set to "Fixed" and a HART address other than zero (e.g. address = 1) must be set. The burst function must then be switched on with HART command 1. This step should be performed before the procedure described below in order to avoid a HART input error of the device being output during commissioning.

1. Select the "Level" measuring mode via the "Measuring mode" parameter.
 - ↳ Menu path: Setup → Measuring mode

⚠ WARNING

Changing the measuring mode affects the span (upper range value)

This situation can result in product overflow.

- ▶ If the measuring mode is changed, the setting for the span (upper range value) must be checked in the "Setup" operating menu and readjusted if necessary.

2. Select a pressure unit via the "Press. eng. unit" parameter, here "mbar" for example.
 - ↳ Menu path: Setup → Press. eng. unit
3. The sensor is unpressurized; perform a position adjustment → 40
4. Set the "Auto dens. corr." parameter to "External value".
 - ↳ Menu path: Expert → Application
5. Perform level calibration (wet or dry)

Result: The measured value output by the Waterpilot corresponds to the level in the deep well corrected by means of the density characteristic line of water.

The TMT72 temperature head transmitter is not suitable for this configuration.

9.11 Linearization

9.11.1 Semi-automatic entry of a linearization table

Example:

In this example, the volume in a tank with a conical outlet should be measured in m³.

Prerequisite:

- The tank can be filled or emptied. The linearization characteristic must rise or fall continuously.
- The "Level" measuring mode has been selected.
- A level calibration has been performed.
- For a description of the parameters mentioned, see the "Description of device parameters" section →  86.

⚠ WARNING**Changing the measuring mode affects the span (upper range value)**

This situation can result in product overflow.

- ▶ If the measuring mode is changed, the setting for the span (upper range value) must be checked in the "Setup" operating menu and readjusted if necessary.

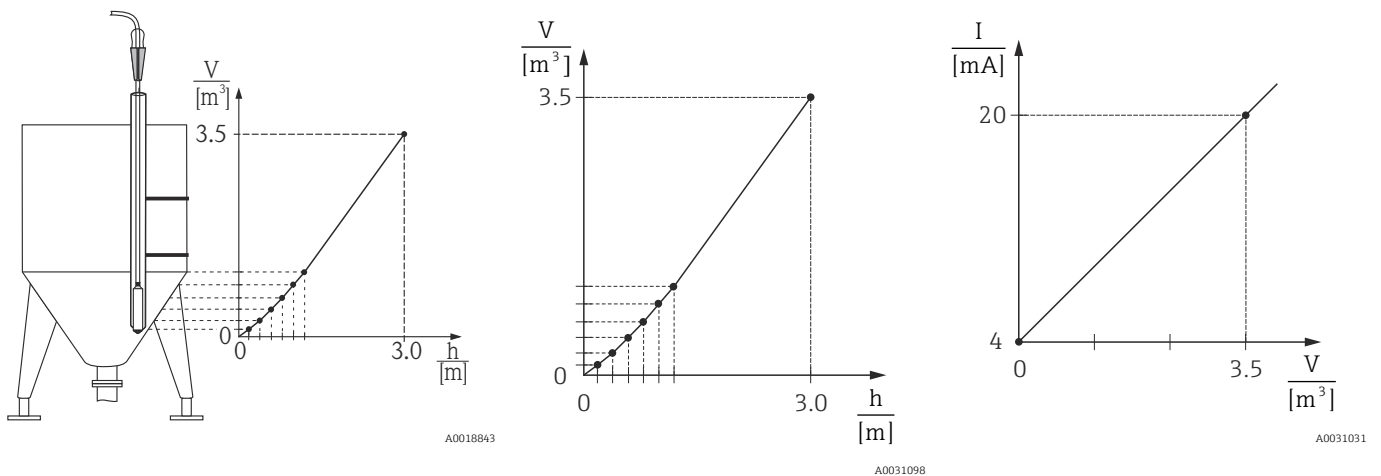

1. Select the "Semiautom. entry" option via the "Lin. mode" parameter.
 - ↳ Menu path: Setup → Extended setup → Linearization → Lin. mode
2. Via the parameter select "Unit after lin." e.g. m^3 .
 - ↳ Menu path: Setup → Extended setup → Linearization → Unit after lin.
3. Fill the tank to the height of the 1st point.
4. The following options are available:
 - ↳ Enter the number of the point in the table using the "Line-numb" parameter e.g. 1.
Menu path: Setup → Extended setup → Linearization → Line numb.
The current level is displayed via the "X-value" parameter.
Menu path: Setup → Extended setup → Linearization → X-value
Using the "Y-val." parameter, enter the corresponding volume value, here $0 m^3$ for example, and confirm the value.
Menu path: Setup → Extended setup → Linearization → Y-value
5. To enter another point in the table, continue filling the tank and select the "Next point" option via the "Edit table" parameter. Enter the next point as explained in Step 4.
 - ↳ Menu path: Setup → Extended setup → Linearization → Edit table
6. Once all the points have been entered in the table, select the "Activate table" option via the "Lin. mode" parameter.
 - ↳ Menu path: Setup → Extended setup → Linearization → Lin. mode

The measured value after linearization is displayed.

- i
 - Error message F510 "Linearization" and alarm current as long as the table is being entered and until the table is activated.
 - The lower range value (= 4 mA) is defined by the smallest point in the table. The upper range value (= 20 mA) is defined by the largest point in the table.
 - Using the parameters "Set LRV" and "Set URV", you can change the allocation of the volume/mass values to the current values.

9.11.2 Manual entry of a linearization table

Example:

In this example, the volume in a tank with a conical outlet should be measured in m^3 .

Prerequisite:

- This is a theoretical calibration, i.e. the points for the linearization table are known.
- The "Level" measuring mode has been selected.
- A level calibration has been performed.
- The linearization characteristic must rise or fall continuously.
- For a description of the parameters mentioned, see the "Description of device parameters" section →  86.

⚠ WARNING

Changing the measuring mode affects the span (upper range value)

This situation can result in product overflow.

- ▶ If the measuring mode is changed, the setting for the span (upper range value) must be checked in the "Setup" operating menu and readjusted if necessary.

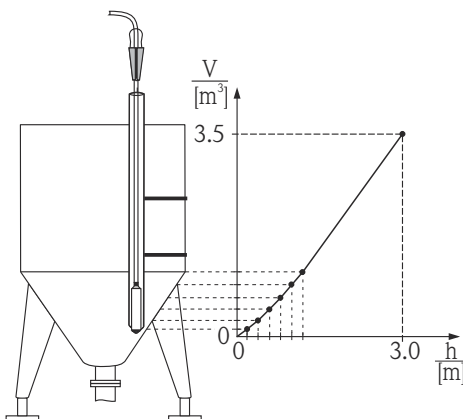

A0018843

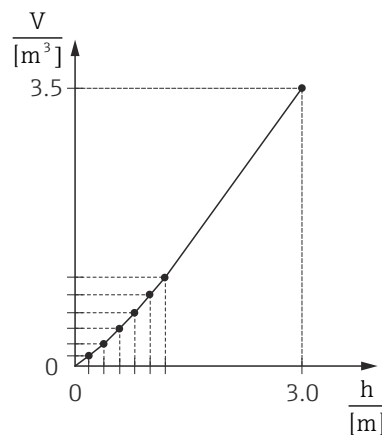

A0031098

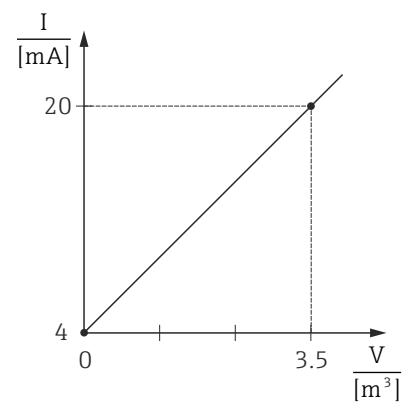

A0031031

1. Select the "Manual entry" option via the "Lin. mode" parameter.
 - ↳ Menu path: Setup → Extended setup → Linearization → Lin. mode
2. Via the parameter select "Unit after lin." e.g. m^3 .
 - ↳ Menu path: Setup → Extended setup → Linearization → Unit after lin.

3. The following options are available:
 - ↳ Enter the number of the point in the table using the "Line-numb" parameter e.g. 1.
Menu path: Setup → Extended setup → Linearization → Line numb.
The level is entered via the "X-value" parameter, here 0 m for example. Confirm your entry.
Menu path: Setup → Extended setup → Linearization → X-value
Using the "Y-val." parameter, enter the corresponding volume value, here 0 m³ for example, and confirm the value.
Menu path: Setup → Extended setup → Linearization → Y-value
4. To enter another point in the table, select the "Next point" option via the "Edit table" parameter. Enter the next point as explained in Step 3.
 - ↳ Menu path: Setup → Extended setup → Linearization → Edit table
5. Once all the points have been entered in the table, select the "Activate table" option via the "Lin. mode" parameter.
 - ↳ Menu path: Setup → Extended setup → Linearization → Lin. mode

The measured value after linearization is displayed.

-  Error message F510 "Linearization" and alarm current as long as the table is being entered and until the table is activated.
- Error message F511/F512 "Linearization" and alarm current as long as the linearization table consists of fewer than 2 points.
- The lower range value (= 4 mA) is defined by the smallest point in the table. The upper range value (= 20 mA) is defined by the largest point in the table.
- Using the parameters "Set LRV" and "Set URV", you can change the allocation of the volume/mass values to the current values.

9.12 Manual entry of a linearization table via operating tool

Using an operating tool based on FDT technology (e.g. FieldCare), you can enter the linearization using a module specially designed for this purpose. This provides you with an overview of the selected linearization, even during entry. In addition, it is possible to configure different tank shapes in FieldCare ("Device operation" → "Device functions" → "Additional functions" → "Linearization table" menu).

-  The linearization table may also be entered manually point by point in the operating tool menu (see Section →  86).

9.13 Backing up or duplicating the device data

The following options are available to you with an operating tool that is based on FDT technology (e.g. FieldCare):

- Storage/recovery of configuration data.
- Duplication of device parameters.
- Transfer of all relevant parameters when replacing electronic inserts.

Use the following parameter for this:

Download select. (visible only in FieldCare)

Navigation

 Expert → System → Management → Download select.

Write permission

Operator/Maintenance/Expert

Description	Selection of data packages for up/download function in Fieldcare and PDM.
Prerequisite	DIP switch set to "SW" and "Damping" set to "on". If you download using the factory setting "Configuration copy", all parameters required for a measurement will be downloaded. The functionality of the "Electronics replace" setting is reserved for Endress+Hauser Service and can be accessed only if the correct device access code is entered.
Selection	<ul style="list-style-type: none"> ■ Configuration copy: This option overwrites general configuration parameters with the exception of the serial number, order number, calibration, position adjustment, application and tag information. ■ Device replacement: This option overwrites general configuration parameters with the exception of the serial number, order number, calibration and position adjustment. ■ Electronics replace: This option overwrites general configuration parameters.
Factory setting	Configuration copy

9.14 Operation and settings via RIA15

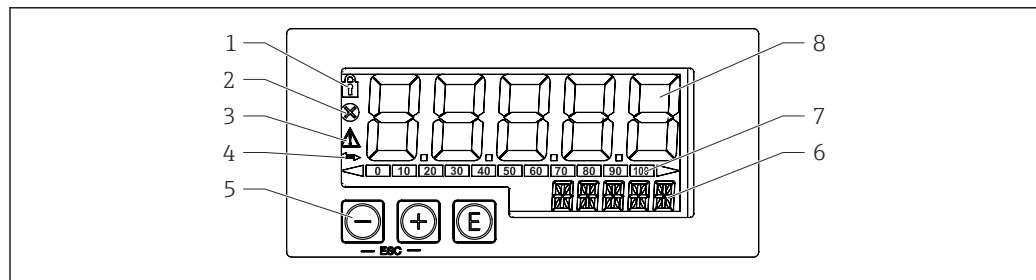

A0017719

 7 Display and operating elements of the process indicator

- 1 Symbol: operating menu disabled
- 2 Symbol: error
- 3 Symbol: warning
- 4 Symbol: HART communication active
- 5 Operating keys "-", "+", "E"
- 6 14-segment display for unit/TAG
- 7 Bar graph with indicators for under range and over range
- 8 5-digit 7-segment display for measured value, digit height 17 mm (0.67 in)

The device is operated using three operating keys on the front of the housing. The device setup can be disabled with a 4-digit user code. If the setup is disabled, a padlock symbol appears on the display when an operating parameter is selected.



Enter key; for calling up the operating menu, confirming the selection/configuration of parameters in the operating menu



Selecting and setting/changing values in the operating menu; pressing the '-' and '+' keys simultaneously takes the user back up a menu level. The configured value is not saved

9.14.1 Operating functions

The operating functions of the process indicator are divided into the following menus. The individual parameters and settings are described in the "Commissioning" section.

 If the operating menu is disabled by means of a user code, the individual menus and parameters can be displayed but not changed. To change a parameter, the user code must be entered. As the display unit can only display digits in the 7-segment display and not alphanumeric characters, the procedure for number parameters is different to that for text parameters. If the operating position contains only numbers as parameters, the operating position is displayed in the 14-segment display and the configured parameter is displayed in the 7-segment display. To edit, press the 'E'-button followed by the user code. If the operating position contains text parameters, only the operating position is initially displayed in the 14-segment display. If the 'E' button is pressed again, the configured parameter is displayed in the 14-segment display. To edit, press the '+' button followed by the user code.

- Setup (SETUP)
Basic device settings
- Diagnostics (DIAG)
Device information, display of error messages
- Expert (EXPRT)
Expert settings for device setup. The Expert menu is protected from editing by an access code (default 0000).

9.14.2 Modes of operation

The process indicator can be used in two different operating modes:

- 4 to 20 mA mode:
In this operating mode, the process indicator is incorporated into the 4 to 20 mA current loop and measures the transmitted current. The variable calculated based on the current value and range limits is displayed in digital form on the 5-digit LCD. In addition, the associated unit and a bar graph can be displayed.
- HART mode:
The indicator is powered via the current loop.
The device can be adjusted under the "Level" menu (see operating matrix). The measured value displayed corresponds to the measured level.
HART communication operates according to the master/slave principle.

For additional information, see BA01170K.

9.14.3 Operating matrix

After power-up:

- ▶ Press the  key twice
 - ↳ The "Level" menu is then available

Using the following operating matrix, a display in percent can be set. To do this, select "Mode" parameter => 4-20 and "Unit" parameter =>%

 The LEVEL menu is only visible if the RIA15 has been ordered with the "Level" option and the indicator is operated in the HART mode (MODE = HART). The basic settings for the device can be made via the RIA15 with this menu.

Menu Setup → Level (LEVEL)

- RIA15 parameter: LEVEL ¹⁾
- Corresponds to device parameter: Level before linearization
- Visible with "Level" option, MODE = HART, device is connected
- Description:

This menu contains the parameters for configuring the pressure gauge for hydrostatic level measurement.

The basic settings for the device can be made via the RIA15 with this menu.

i Once the LEVEL menu item is opened, the following parameters are automatically adjusted in the device for easier operation:

- Operating mode: level
- Calibration mode: Dry
- Level selection: In pressure
- Lin mode: Linear

It is possible to reset these parameters to the factory default settings by performing a reset.

Menu Setup → Level (LEVEL) → PUNIT

- RIA15 parameter: PUNIT
- Corresponds to device parameter: Press. eng. unit
- Values (default in bold)
 - **mbar** ²⁾
 - **bar** ²⁾
 - kPa
 - PSI
- Description: Use this function to select the unit for pressure

Menu Setup → Level (LEVEL) → LUNIT

- RIA15 parameter: LUNIT
- Corresponds to device parameter: Output unit
- Values (default in bold)
 - %
 - m
 - inch
 - feet
- Description: Use this function to select the unit for level

Menu Setup → Level (LEVEL) → TUNIT

- RIA15 parameter: TUNIT
- Corresponds to device parameter: Temperature unit
- Values (default in bold)
 - °C
 - °F
 - K
- Description: Use this function to select the unit for temperature

1) If the measured value that is read out is too large, it is displayed as "9999.9", for example. To display a valid measured value, the pressure unit (PUNIT) (or level unit (LUNIT)) must be set to suit the measuring range.

2) Default: depends on the sensor nominal range or as per order specifications

Menu Setup → Level (LEVEL) → ZERO

- RIA15 parameter: ZERO
- Corresponds to device parameter: Pos. zero adjust
- Values (default in bold)
 - **NO**
 - YES
- Visible with: gauge pressure measuring cell
- Description:
 - For performing a position adjustment (gauge pressure measuring cell).
 - The value 0.0 is assigned to the pressure value present. The current value is also corrected.

Menu Setup → Level (LEVEL) → P_LRV

- RIA15 parameter: P_LRV
- Corresponds to device parameter: Empty pressure
- Values (default in bold)
 - -1999.9 ... 9999.9
 - **Gauge pressure measuring cell: Sensor LRL**
 - Absolute pressure sensor: 0
- Description:

Pressure-based empty calibration using keys -, +, E. Detailed description/valid value range: any value within the specified range ^{1) 3)}. Number of decimal places depends on the configured pressure unit.

Menu Setup → Level (LEVEL) → P_URV

- RIA15 parameter: P_URV
- Corresponds to device parameter: Full pressure
- Values (default in bold)
 - -1999.9 ... 9999.9
 - **Sensor URL**
- Description:

Pressure-based full calibration using keys -, +, E. Detailed description/valid value range: any value within the specified range ^{1) 3)}. Number of decimal places depends on the configured pressure unit.

Menu Setup → Level (LEVEL) → EMPTY

- RIA15 parameter: EMPTY
- Corresponds to device parameter: Empty calibration
- Values (default in bold)
 - -1999.9 ... 9999.9
 - **0**
- Description:

Level-based empty calibration using keys -, +, E. Detailed description/valid value range: any value within the specified range ^{1) 3)}. Number of decimal places depends on the configured level unit.

Menu Setup → Level (LEVEL) → FULL

- RIA15 parameter: FULL
- Corresponds to device parameter: Full calibration
- Values (default in bold)
 - -1999.9 ... 9999.9
 - **100**
- Description:

Level-based full calibration using keys -, +, E. Detailed description/valid value range: any value within the specified range ^{1) 3)}. Number of decimal places depends on the configured level unit.

3) The values entered for "Empty calib./Full calib.", "Empty pressure/Full pressure" and "Set LRV/Set URV" must be at least 1% apart. The value will be rejected, and a message displayed, if the values are too close together. Further limit values are not checked, i.e. the values entered must be appropriate for the sensor module and the measuring task for the measuring instrument to be able to measure correctly.

Menu Setup → Level (LEVEL) → LEVEL

- RIA15 parameter: LEVEL
- Corresponds to device parameter: Level before linearization
- Values (default in bold)
Measured value
- Description:
Displays the measured level. Number of decimal places depends on the configured level unit.

Menu Setup → Level (LEVEL) → RESET

- RIA15 parameter: RESET
- Corresponds to device parameter: Enter reset code
- Values (default in bold)
 - **No**
 - YES
- Description:
Reset the device to factory settings

 Any additional settings such as linearizations must be made using FieldCare or DeviceCare.

 Additional information is available in the RIA15 Operating Instructions BA01170K.

10 Diagnostics and troubleshooting

10.1 General troubleshooting

Device is not responding

- Supply voltage does not match the voltage specified on the nameplate.
 - ↳ Apply correct voltage.
- Supply voltage has incorrect polarity.
 - ↳ Correct the polarity.
- Connecting cables are not making contact with the terminals.
 - ↳ Check the connection of the cables and correct if necessary.

Output current < 3.6 mA

Signal cable is not wired correctly.

Electronics unit is defective.

- ↳ Check wiring.

Device measuring incorrectly

Parameter configuration error

- ↳ Check and correct parameter configuration (see below).

HART communication is not working

- Missing or incorrectly installed communication resistor
 - ↳ Install the communication resistor (250 Ω) correctly.
- Commubox is not properly connected.
 - ↳ Connect Commubox correctly.
- Commubox is not set to "HART".
 - ↳ Set Commubox selector switch to "HART".

RIA15 no display

- The polarity of the supply voltage is wrong
 - ↳ Correct the polarity
- Connecting cables are not in contact with the terminals
 - ↳ Ensure electrical contact between the cable and the terminal
- RIA15 defective
 - ↳ Replace RIA15

RIA15 start sequence keeps running through

Supply voltage too low

- ↳ Increase supply voltage
- ↳ Switch off backlight

10.2 Diagnostic events in the operating tool

10.2.1 Diagnostic message

Faults detected by the self-monitoring system of the measuring instrument are displayed as a diagnostic message in alternation with the measured value display.

Status signals

The table lists the messages that may occur. The ALARM STATUS parameter shows the message with the highest priority. The device has four different status information codes according to NE 107:

F Failure

A device fault has occurred. The measured value is no longer valid.

M Maintenance required

Maintenance is required. The measured value is still valid.

C Function check

The device is in the service mode (e.g. during a simulation).

S Out of specification

The device is being operated:

- Outside its technical specifications (e.g. during startup or cleaning)
- Outside the configuration performed by the user (e.g. level outside the configured range)

Diagnostic event and event text

The fault can be identified by means of the diagnostic event.

The event text helps you by providing information about the error.

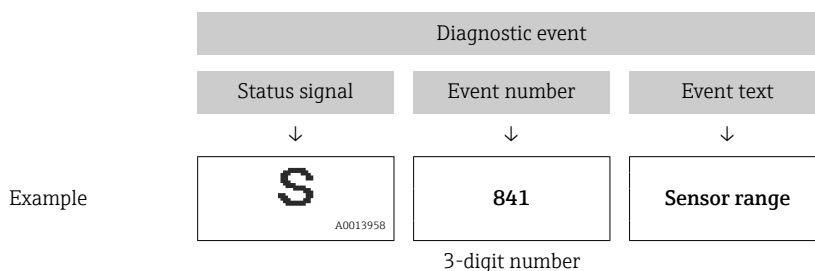

If several diagnostic events are pending at the same time, only the diagnostic message with the highest priority is displayed.





Other diagnostic messages that are pending can be viewed in the **Diagnostic list** submenu →  120.

 Past diagnostic messages that are no longer pending are shown in the **Event logbook** submenu →  121.

10.2.2 Diagnostic event in RIA15

A device diagnostic event is not directly shown in the RIA15. The fault F911 only appears directly on the RIA15 in the event of a device alarm.

Displaying a diagnostic event in the RIA15

1. Navigate to: DIAG/TERR
2. Press 
3. Press 
4. Press 
5. Press  3 times
6. Press 
 - ↳ The device diagnostic event is shown on the RIA15 display.

10.2.3 Diagnostic list

General messages

Code: 0

- Description: no fault
- Cause: -
- Corrective measure: -

"F" messages**Code: F002**

- Description: Sensor unknown
- Cause: Sensor does not suit the device (electronic sensor module nameplate)
- Corrective measure: Contact Endress+Hauser Service

Code: F062

- Description: Sensor conn.
- Cause:
 - Sensor defective
 - Electromagnetic effects are greater than specifications in the technical data. This message appears for a short time only
- Corrective measure:
 - Check the sensor module cable
 - Contact Endress+Hauser Service.

Code: F081

- Description: Initialization
- Cause:
 - Sensor defective
 - Electromagnetic effects are greater than specifications in the technical data. This message appears for a short time only
- Corrective measure:
 - Check sensor cable
 - Contact Endress+Hauser Service.

Code: F083

- Description: Memory content
- Cause:
 - Sensor defective
 - Electromagnetic effects outside the permitted range. This message appears for a short time only
- Corrective measure:
 - Restart the device.
 - Contact Endress+Hauser Service.

Code: F140

- Description: Working range P
- Cause:
 - Overpressure and low pressure present
 - Electromagnetic effects outside the permitted range
 - Faulty sensor.
- Corrective measure:
 - Check the process pressure.
 - Check the sensor range.

Code: F261

- Description: Electronic module
- Cause:
 - Main electronics defective.
 - Fault in the main electronics.
- Corrective measure: Restart the device

Code: F282

- Description: Memory
- Cause:
 - Fault in the main electronics.
 - Main electronics defective.
- Corrective measure: Restart the device

Code: F283

- Description: Memory content
- Cause:
 - Main electronics defective
 - Electromagnetic effects are greater than specifications in the technical data.
 - The supply voltage is disconnected when writing.
 - An error occurred when writing.
- Corrective measure: Perform a reset

Code: F411

- Description: Up-/download
- Cause:
 - Upload/download
 - During the download, the data are not correctly transmitted to the processor, e.g. because of open cable connections, spikes (ripple) on the supply voltage or electromagnetic effects
- Corrective measure:
 - Repeat download
 - Use other file
 - Perform a reset

Code: F510

- Description: Linearization
- Cause: The linearization table is being edited.
- Corrective measure:
 - Conclude entries
 - Select "linear"

Code: F511

- Description: Linearization
- Cause: The linearization table consists of less than 2 points.
- Corrective measure:
 - Table too small
 - Correct the table.
 - Accept the table.

Code: F512

- Description: Linearization
- Cause: The linearization table is not monotonic increasing or decreasing.
- Corrective measure:
 - Table not monotonic
 - Correct the table.
 - Accept the table.

Code: F841

- Description: Sensor range
- Cause:
 - Overpressure or low pressure present
 - Sensor defective
- Corrective measure:
 - Check the pressure value.
 - Contact Endress+Hauser Service

Code: F882

- Description: Input signal
- Cause: External measured value is not received or displays a failure status.
- Corrective measure:
 - Check the bus
 - Check the source device
 - Check the setting.

"M" messages**Code: M002**

- Description: Sens. unknown
- Cause: Sensor module does not suit the device (electronic sensor nameplate). Device continues measuring.
- Corrective measure: Contact Endress+Hauser Service

Code: M283

- Description: Memory content
- Cause:
 - Cause as indicated for F283
 - Correct measurement can continue as long as you do not need the peakhold indicator function.
- Corrective measure: Perform a reset

Code: M431

- Description: Adjustment
- Cause: The adjustment performed would cause the nominal sensor range to be exceeded or undershot.
- Corrective measure:
 - Check the measuring range.
 - Check position adjustment
 - Check the setting.

Code: M434

- Description: Scaling
- Cause:
 - Values for calibration (e.g. lower range value and upper range value) are too close together.
 - Lower range value and/or upper range value exceed or fall below the sensor range limits.
 - The sensor was replaced and the customer-specific configuration does not suit the sensor module.
 - Unsuitable download carried out.
- Corrective measure:
 - Check the measuring range.
 - Check the setting.
 - Contact Endress+Hauser Service

Code: M438

- Description: Data set
- Cause:
 - The supply voltage is disconnected when writing.
 - An error occurred when writing.
- Corrective measure:
 - Check the setting.
 - Restart the device.

Code: M882

- Description: Input signal
- Cause: External measured value displays a warning status.
- Corrective measure:
 - Check the bus
 - Check the source device
 - Check the setting.

"C" messages**Code: C412**

- Description: Backup in progress
- Cause: Downloading
- Corrective measure: Wait for download to complete

Code: C482

- Description: Simul. output
- Cause: Simulation of the current output is switched on, i.e. the device is not measuring at present.
- Corrective measure: End the simulation

Code: C484

- Description: Error simul.
- Cause: Fault state simulation is switched on, i.e. the device is not measuring at present.
- Corrective measure: End the simulation

Code: C485

- Description: Simulation value
- Cause: Simulation is switched on, i.e. the device is not measuring at present.
- Corrective measure: End the simulation

Code: C824

- Description: Process pressure
- Cause:
 - Overpressure or low pressure present.
 - Electromagnetic effects outside the permitted range. (This message appears for a short time only)
- Corrective measure:
 - Check the pressure value.
 - Restart the device.
 - Perform a reset

"S" messages**Code: S110**

- Description: Working range T
- Cause:
 - Excess temperature or low temperature present
 - Electromagnetic effects outside the permitted range
 - Sensor defective
- Corrective measure:
 - Check the process temperature
 - Check the temperature range

Code: S140

- Description: Working range P LP/HP
- Cause:
 - Overpressure or low pressure present
 - Electromagnetic effects outside the permitted range
 - Sensor defective
- Corrective measure:
 - Check the process pressure.
 - Check the sensor range.

Code: S822

- Description: Process temp. LP/HP
- Cause:
 - The temperature measured in the sensor is greater than the upper nominal temperature of the sensor
 - The temperature measured in the sensor is lower than the lower nominal temperature of the sensor
- Corrective measure:
 - Check the temperature.
 - Check the setting.

Code: S841

- Description: Sensor range
- Cause:
 - Overpressure or low pressure present
 - Sensor defective
- Corrective measure:
 - Check the pressure value.
 - Contact Endress+Hauser Service

Code: S971

- Description: Adjustment
- Cause:
 - The current is outside the permitted range 3.8 to 20.5 mA
 - The present pressure value is outside the configured measuring range (but may be within the sensor module range)
 - The adjustment performed would cause the nominal sensor range to be exceeded or undershot.
- Corrective measure:
 - Check the pressure value.
 - Check the measuring range.
 - Check the setting.

10.3 Troubleshooting specific to the device with optional Pt100

No measuring signal

- 4 to 20 mA cable not connected correctly
 - ↳ Connect device as per →  23
- No power supplied via the 4 to 20 mA cable
 - ↳ Check current loop
- Supply voltage too low (min. 10.5 V_{DC})
 - ↳ Check supply voltage
 - ↳ Overall resistance greater than max. load resistance
- Device is defective
 - ↳ Replace the device

Temperature measured value is inaccurate/incorrect (only for device with Pt100)

Pt100 connected in 2-wire circuit, cable resistance was not compensated for, cable not correct



- ↳ Compensate for the cable resistance
- ↳ Connect Pt100 as 3-wire or 4-wire circuit

10.4 Troubleshooting specific to TMT72 temperature head transmitter

No measuring signal

- 4 to 20 mA cable not connected correctly
 - ↳ Connect device as per →  23
- No power supplied via the 4 to 20 mA cable
 - ↳ Check current loop
- Supply voltage too low (min. 10.5 V_{DC})
 - ↳ Check supply voltage
 - ↳ Overall resistance greater than max. load resistance

Failure current ≤ 3.6 mA or ≥ 21 mA

- Pt100 not connected correctly
 - ↳ Connect device as per →  23
- 4 to 20 mA cable not connected correctly
 - ↳ Connect device as per →  23
- Pt100 resistance thermometer defective
 - ↳ Replace the device
- Temperature head transmitter defective
 - ↳ Replace the temperature head transmitter

Measured value is inaccurate/incorrect

Pt100 connected in 2-wire circuit, cable resistance was not compensated for

- ↳ Compensate for the cable resistance
- ↳ Connect Pt100 as 3-wire or 4-wire circuit

10.5 Response of output to failures

The behavior of the current output in the event of faults is defined in the following parameters:

- "Alarm behav. P (050)"
- "Output fail mode (190)"
- "High Alarm Curr. (052)"

10.6 Resetting the device

10.6.1 Resetting to factory settings (reset)

 By entering a certain code, you can completely or partially reset the entries for the parameters to the factory settings ⁴⁾. Enter the code via the "Enter reset code" parameter (menu path: "Diagnosis" → "Enter reset code").

There are various reset codes for the device. The following table illustrates which parameters are reset by the particular reset codes. To perform a reset, operation must be unlocked (see the "Locking/unlocking operation" section). →  35

Any customer-specific configuration carried out at the factory is not affected by a reset (customer-specific configuration remains). If you want to change the customer-specific configuration carried out at the factory, please contact Endress+Hauser Service. As there is no separate service level, the order code and serial number can be changed without a specific release code.

4) The factory setting for the individual parameters is specified in the parameter description

Reset code ⁵⁾

- **62** (PowerUp reset (warm start))
 - The device is restarted.
 - Data is read back anew from the EEPROM (process is reinitialized).
 - Any simulation which may be running is ended.
 - **333** (User reset)
 - This code resets all the parameters apart from: device tag, linearization table, operating hours, event logbook, current trim 4 mA , current trim 20 mA
 - Any simulation which may be running is ended.
 - The device is restarted.
 - **7864** (Total reset)
 - This code resets all the parameters apart from: operating hours, event logbook
 - Any simulation which may be running is ended.
 - The device is restarted.
-  After a "Total reset" in FieldCare you have to press the "refresh" button in order to ensure that the units are also reset.

5) To be entered in "System" → "Management" → "Enter reset code"

11 Maintenance

- Terminal box: Keep the GORE-TEX® filter free from contamination
- Device extension cable: Keep the Teflon filter in the pressure compensation tube free from contamination
- Check the process membrane for buildup at suitable intervals.

11.1 Exterior cleaning

Please note the following points when cleaning the device:

- The cleaning agents used should not corrode the surface and the seals.
- Mechanical damage to the process membrane, e.g. due to sharp objects, must be avoided.
- Only clean the terminal box with water or with a cloth dampened with very diluted ethanol.

12 Repair

12.1 General information

12.1.1 Repair concept

Repairs are not possible.

12.1.2 Replacing a device

Once a complete device has been replaced, the parameters can be transferred back into the device using FieldCare:

Prerequisite: The configuration of the old device was saved previously to the computer using FieldCare.

You can continue to measure without performing a new calibration.

12.2 Spare parts

Product spare parts that are currently available can be found online at:

www.endress.com/onlinetools



Measuring instrument serial number:

- Located on the device and spare part nameplate.
- Can be read out via the "Serial number" parameter in the "Instrument info" submenu.

12.3 Return

The requirements for safe device return can vary depending on the device type and national legislation.

1. Refer to the web page for information: <https://www.endress.com>
2. If returning the device, pack the device in such a way that it is reliably protected against impact and external influences. The original packaging offers the best protection.

12.4 Disposal



If required by the Directive 2012/19/EU on waste electrical and electronic equipment (WEEE), the product is marked with the depicted symbol in order to minimize the disposal of WEEE as unsorted municipal waste. Do not dispose of products bearing this marking as unsorted municipal waste. Instead, return them to the manufacturer for disposal under the applicable conditions.

13 Overview of the operating menu

i Depending on the parameter configuration, not all submenus and parameters are available. Information on this can be found in the parameter description under "Prerequisite".

Setup	Description
Operating mode	→ 89
Press. eng. unit	→ 91
Corrected press.	→ 93
Pos. zero adjust (relative pressure sensor)	→ 90
Calib. offset (absolute pressure sensor)	→ 90
Empty calib. ("Level" measuring mode and "Calibration mode" = wet)	→ 95
Full calib. ("Level" measuring mode and "Calibration mode" = wet)	→ 96
Set LRV ("Pressure" measuring mode)	→ 92
Set URV ("Pressure" measuring mode)	→ 92
Damping	→ 90
Level before Lin ("Level" measuring mode)	→ 98
Pressure af.damp	→ 93

Setup →	Extended setup	Description
	Code definition	→ 86
	Device tag	→ 87
	Operator code	→ 86

Setup →	Extended setup →	Level ("Level" measuring mode)	Description
		Level selection	→ 94
		Output unit	→ 94
		Height unit	→ 94
		Calibration mode	→ 95
		Empty calib.	→ 95
		Empty pressure	→ 95
		Empty height	→ 96
		Full calib.	→ 96
		Full pressure	→ 96
		Full height	→ 97
		Adjust density	→ 97
		Process density	→ 97
		Level before lin	→ 98

Setup →	Extended setup →	Linearization	Description
		Lin. mode	→ 99
		Unit after lin.	→ 99
		Line-numb:	→ 99





Setup →	Extended setup →	Linearization	Description
		X-val	→ 100
		Y-val	→ 100
		Edit table	→ 100
		Tank description	→ 101
		Tank content	→ 101













Setup →	Extended setup →	Current output	Description
		Alarm behav. P	→ 104
		Output fail mode	→ 104
		Max. alarm curr.	→ 104
		Set min. current	→ 105
		Output current	→ 104
		Get LRV (only "Pressure")	→ 105
		Set LRV	→ 105
		Get URV (only "Pressure")	→ 105
		Set URV	→ 106







Diagnosis	Description
Diagnostic code	→ 118
Last diag. code	→ 118
Min. meas. press.	→ 118
Max. meas. press.	→ 118







Diagnosis →	Diagnostics List	Description
	Diagnostic 1	→ 120
	Diagnostic 2	→ 120
	Diagnostic 3	→ 120
	Diagnostics 4	→ 120
	Diagnostics 5	→ 120
	Diagnostics 6	→ 120
	Diagnostics 7	→ 120
	Diagnostics 8	→ 120
	Diagnostics 9	→ 120
	Diagnostics 10	→ 120

Diagnosis →	Event logbook	Description
	Last diag. 1	→ 121
	Last diag. 2	→ 121
	Last diag. 3	→ 121
	Last diag. 4	→ 121
	Last diag. 5	→ 121
	Last diag. 6	→ 121

Diagnosis →	Event logbook	Description
	Last diag. 7	→  121
	Last diag. 8	→  121
	Last diag. 9	→  121
	Last diag. 10	→  121

Diagnosis →	Instrument Info	Description
	Firmware Version	→  87
	Serial number	→  87
	Ext. order code	→  87
	Order Identifier	→  88
	Cust. tag number	→  87
	Device tag	→  87
	ENP version	→  88
	Config. counter	→  119
	LRL sensor	→  102
	URL sensor	→  102
	Manufacturer ID	→  110
	Device type code	→  110
	Device revision	→  110

Diagnosis →	Measured values	Description
	Level before lin	→  98
	Tank content	→  101
	Pressure measured	→  92
	Sensor pressure	→  92
	Corrected press.	→  93
	Pressure af.damp	→  93
	Sensor temp.	→  91



Diagnosis →	Simulation	Description
	Simulation mode	→  122
	Sim. pressure	→  122
	Sim. level	→  122
	Sim. tank cont.	→  123
	Sim. current	→  123
	Sim. alarm/warning	→  123









Diagnosis →	Enter reset code	Description
	Enter reset code	→  89

13.1 Overview of parameters in the "Expert" menu

 The following table lists all of the parameters that can be included in the "Expert" menu. The page reference indicates where a description of the parameter can be found in the manual.







Depending on the device version and the parameter configuration, not all submenus and parameters are available in every device. Information on this can be found in the parameter description under "Prerequisite".







Expert →	System	Description
	Code definition	→  86
	Operator code	→  86

Expert →	System →	Instrument Info	Description
		Cust. tag number	→  87
		Device tag	→  87
		Serial number	→  87
		Firmware Version	→  87
		Ext. order code	→  87
		Order Identifier	→  88
		ENP version	→  88
		Electr.Serial No	→  88
		Sensor serial no.	→  88

Expert →	System →	Administration	Description
		Enter reset code	→  89

Expert →	Measurement	Description
	Operating mode	→  89

Expert →	Measurement →	Basic Setup	Description
		Pos. zero adjust	→  90
		Calib. Offset	→  90
		Damping	→  90
		Press. eng. unit	→  91
		Temp. Eng. Unit	→  91
		Sensor temp.	→  91

Expert →	Measurement →	Pressure	Description
		Set LRV	→  92
		Set URV	→  92
		Pressure measured	→  92
		Sensor pressure	→  92
		Corrected press.	→  93
		Pressure af.damp	→  93

Expert →	Measurement →	Level	Description
		Level selection	→ 94
		Output unit	→ 94
		Height unit	→ 94
		Calibration mode	→ 95
		Empty calib.	→ 95
		Empty pressure	→ 95
		Empty height	→ 96
		Full calib.	→ 96
		Full pressure	→ 96
		Full height	→ 97
		Density unit	→ 97
		Adjust density	→ 97
		Process density	→ 97
		Level before lin.	→ 98

Expert →	Measurement →	Linearization	Description
		Lin. mode	→ 99
		Unit after lin.	→ 99
		Line-numb:	→ 99
		X-val	→ 100
		Y-val	→ 100
		Edit table	→ 100
		Tank description	→ 101
		Tank content	→ 101

Expert →	Measurement →	Sensor limits	Description
		Lower range limit	→ 102
		URL sensor	→ 102

Expert →	Measurement →	Sensor trim	Description
		Lo trim measured	→ 103
		Hi trim measured	→ 103
		Lo Trim Sensor	→ 103
		Hi Trim Sensor	→ 103

Expert →	Output →	Current output	Description
		Output current	→ 104
		Alarm behav. P	→ 104
		Output fail mode	→ 104
		Max. alarm curr.	→ 104
		Set min. current	→ 105

Expert →	Output→	Current output	Description
		Get LRV ("Pressure" only)	→ 105
		Set LRV	→ 105
		Get URV ("Pressure" only)	→ 105
		Set URV	→ 106
		Startcurrent	→ 106
		Curr. Trim 4 mA	→ 106
		Curr. Trim 20 mA	→ 107
		Offset Trim 4 mA	→ 107
		Offset Trim 20 mA	→ 107

Expert →	Communication→	HART Config	Description
		Burst Mode	→ 108
		Burst Option	→ 108
		Current Mode	→ 108
		Bus Address	→ 108
		Preamble Number	→ 109

Expert →	Communication→	HART Info	Description
		Device type code	→ 110
		Device revision	→ 110
		Manufacturer ID	→ 110
		HART version	→ 110
		Descriptor	→ 110
		HART Message	→ 110
		HART Date	→ 111

Expert →	Communication→	HART Output	Description
		Primary value is	→ 112
		Primary value	→ 112
		Secondary val. is	→ 112
		Secondary value	→ 112
		Third value is	→ 113
		Third value	→ 113
		4th value is	→ 113
		4th value	→ 114

Expert →	Communication→	HART Input	Description
		HART input val.	→ 115
		HART input stat.	→ 115







Expert →	Communication→	HART Input	Description
		HART input unit	→ 115
		HART input form.	→ 115

Expert →	Application	Description
	Electr. Delta P	→ 117
	Fixed ext. value	→ 117
	Auto dens. corr.	→ 117

Expert →	Diagnosis	Description
	Diagnostic code	→ 118
	Last diag. code	→ 118
	Reset Logbook	→ 118
	Min. meas. press.	→ 118
	Max. meas. press.	→ 118
	Reset Peakhold	→ 119
	Operating hours	→ 119
	Config. counter	→ 119

Expert →	Diagnosis→	Diagnostics List	Description
		Diagnostic 1	→ 120
		Diagnostic 2	→ 120
		Diagnostic 3	→ 120
		Diagnostics 4	→ 120
		Diagnostics 5	→ 120
		Diagnostics 6	→ 120
		Diagnostics 7	→ 120
		Diagnostics 8	→ 120
		Diagnostics 9	→ 120
		Diagnostics 10	→ 120

Expert →	Diagnosis→	Event logbook	Description
		Last diag. 1	→ 121
		Last diag. 2	→ 121
		Last diag. 3	→ 121
		Last diag. 4	→ 121
		Last diag. 5	→ 121
		Last diag. 6	→ 121
		Last diag. 7	→ 121
		Last diag. 8	→ 121
		Last diag. 9	→ 121
		Last diag. 10	→ 121

Expert →	Diagnosis→	Simulation	Description
		Simulation mode	→  122
		Sim. pressure	→  122
		Sim. level	→  122
		Sim. tank cont.	→  123
		Sim. current	→  123
		Sim. alarm/warning	→  123

14 Description of device parameters

14.1 Expert → System

Operator code	
<hr/>	
Write permission	Operators/Service engineers/Expert
Description	Use this function to enter a code to lock or unlock operation.
User entry	<ul style="list-style-type: none"> ■ To lock: Enter a number ≠ the release code (value range: 1 to 9999). ■ To unlock: Enter the release code.
Note	The release code is "0" in the order configuration. Another release code can be defined in the "Code definition" parameter. If the user has forgotten the release code, the release code can be visible by entering the number "5864".
Factory setting	0

Code definition	
<hr/>	
Write permission	Operators/Service engineers/Expert
Description	Use this function to enter a release code with which the device can be unlocked.
Options	A number from 0 to 9999
Factory setting	0

14.2 Expert → System → Instrument info

Cust. tag number

Write permission	Operators/Service engineers/Expert
Description	Enter the device tag, e.g. TAG number (max. 8 alphanumeric characters).
Factory setting	No entry or according to order specifications

Device tag

Write permission	Operators/Service engineers/Expert
Description	Enter the device tag, e.g. TAG number (max. 32 alphanumeric characters).
Factory setting	No entry or according to order specifications

Serial number

Write permission	Parameter is read only. Only Endress+Hauser Service has write permission.
Description	Displays the serial number of the device (11 alphanumeric characters).

Firmware Version

Write permission	No write permissions. Parameter is read only.
Description	Displays the firmware version.

Ext. order code

Write permission	Parameter is read only. Only Endress+Hauser Service has write permission.
Description	Displays extended order number.
Factory setting	According to order specifications

Order identifier

Write permission	Parameter is read only. Only Endress+Hauser Service has write permission.
Description	Displays the order identifier.
Factory setting	According to order specifications

ENP version

Write permission	No write permissions. Parameter is read only.
Description	Displays the ENP version (ENP = electronic nameplate)

Electr.serial no.

Write permission	No write permissions. Parameter is read only.
Description	Displays the serial number of the main electronics (11 alphanumeric characters).

Sensor serial no.

Write permission	No write permissions. Parameter is read only.
Description	Displays the serial number of the main electronics (11 alphanumeric characters).

14.3 Expert → System → Management

Enter reset code

Write permission	Operators/Service engineers/Expert
Description	Reset parameters completely or partially to the factory values or order configuration by entering a reset code, see "Resetting to factory settings (reset)" section.
Factory setting	0

14.4 Expert → Measurement → Measuring mode

Measuring mode

⚠ WARNING

Changing the measuring mode affects the span (URV)

This situation can result in product overflow.

- ▶ If the measuring mode is changed, the setting for the span (URV) must be checked in the "Setup" operating menu and readjusted if necessary.

Write permission	Operators/Service engineers/Expert
Description	Select the measuring mode. The operating menu is structured differently depending on the measuring mode selected.
Options	<ul style="list-style-type: none"> ▪ Pressure ▪ Level
Factory setting	Pressure or according to order specifications

14.5 Expert → Measurement → Basic setup

Pos. zero adjust

Write permission	Operators/Service engineers/Expert
Description	Position adjustment – the pressure difference between zero (set point) and the measured pressure need not be known.
Example	<ul style="list-style-type: none"> ■ Measured value = 2.2 mbar (0.033 psi) ■ You correct the measured value via the "Pos. zero adjust" parameter with the "Confirm" option. This means that you are assigning the value 0.0 to the pressure present. ■ Measured value (after position adjustment) = 0.0 mbar ■ The current value is also corrected.
Options	<ul style="list-style-type: none"> ■ Confirm ■ Cancel
Factory setting	Cancel

Calib. offset

Write permission	Service engineers/Expert
Description	Position adjustment – the pressure difference between the set point and the measured pressure must be known.
Example	<ul style="list-style-type: none"> ■ Measured value = 982.2 mbar (14.73 psi) ■ You correct the measured value with the value entered (e.g. 2.2 mbar (0.033 psi)) via the "Calib. Offset" parameter. This means that you are assigning the value 980.0 (14.7 psi) to the pressure present. ■ Measured value (after pos. zero adjust) = 980.0 mbar (14.7 psi) ■ The current value is also corrected.
Factory setting	0.0

Damping

Write permission	Operators/Service engineers/Expert (if the "Damping" DIP switch is set to "on")
Description	Enter damping time (time constant τ). The damping affects the speed at which the measured value reacts to changes in pressure.
Input range	0.0 to 999.0 s
Factory setting	2.0 sec. or according to order specifications

Press. eng. unit

Write permission	Operators/Service engineers/Expert
Description	Select the pressure engineering unit. If a new pressure engineering unit is selected, all pressure-specific parameters are converted and displayed with the new unit.
Options	<ul style="list-style-type: none"> ■ mbar, bar ■ mmH2O, mH2O, inH2O ■ ftH2O ■ Pa, kPa, MPa ■ psi ■ mmHg, inHg ■ kgf/cm²
Factory setting	mbar or bar depending on the nominal measuring range of the sensor module, or as per order specifications

Temp. eng. unit

Write permission	Service engineers/Expert
Description	Select the unit for the temperature measured values.
Options	<ul style="list-style-type: none"> ■ °C ■ °F ■ K
Note	The setting affects the unit for the "Sensor temp." parameter.
Factory setting	°C

Sensor temp.

Write permission	No write permissions. Parameter is read only.
Description	Displays the temperature currently measured in the sensor module. This can deviate from the process temperature.

14.6 Expert → Measurement → Pressure

Set LRV

Write permission	Operators/Service engineers/Expert
Description	Set the pressure value, level or content for the lower current value (4 mA).
Factory setting	<ul style="list-style-type: none"> ■ 0.0 % in Level measuring mode ■ 0.0 mbar/bar or in accordance with ordering information in Pressure measuring mode

Set URV

Write permission	Operators/Service engineers/Expert
Description	Set the pressure value, level or content for the upper current value (20 mA).
Factory setting	<ul style="list-style-type: none"> ■ 100.0 % in Level measuring mode ■ URL Sensor or according to ordering information in Pressure measuring mode

Meas. pressure

Write permission	No write permissions. Parameter is read only.
Description	Displays the measured pressure after sensor trim, position adjustment and damping.

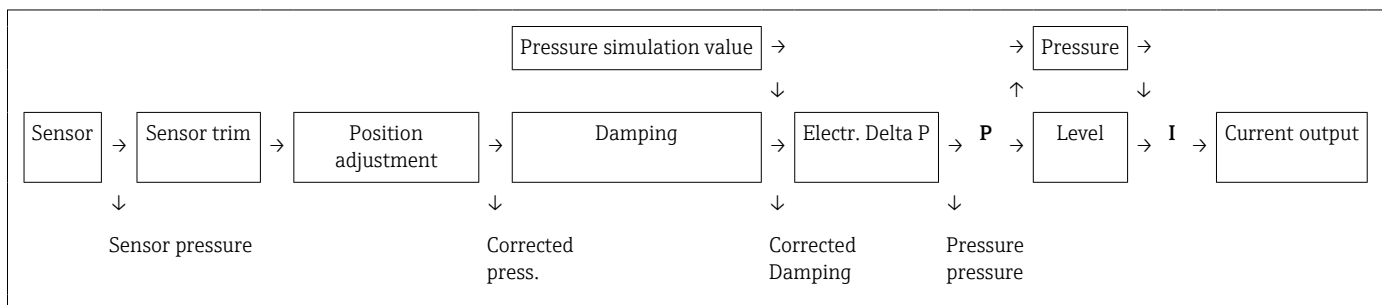

Sensor pressure

Write permission	No write permissions. Parameter is read only.
Description	Displays the measured pressure before the sensor trim.

Corrected press.

Write permission No write permissions. Parameter is read only.

Description Displays the measured pressure after sensor trim and position adjustment.

Pressure af.damp

Write permission No write permissions. Parameter is read only.

Description Displays the measured pressure after sensor trim, position adjustment and damping.

14.7 Expert → Measurement → Level

Level selection	
Write permission	Operator/Maintenance/Expert
Description	Select the method for calculating the level
Options	<ul style="list-style-type: none"> ▪ In pressure If this option is selected, specify two pressure/level value pairs. The level value is displayed directly in the unit that you select via the "Output unit" parameter. ▪ In height If this option is selected, specify two height/level value pairs. From the measured pressure, the device first calculates the height using the density. This information is then used to calculate the level in the "Output unit" selected using the two value pairs specified.
Factory setting	In pressure
Output unit	
Description	Select the unit for the measured value display for the level before linearization.
Note	The selected unit is used only to describe the measured value i.e. when a new output unit is selected, the measured value is not converted.
Example	<ul style="list-style-type: none"> ▪ Current measured value: 0.3 ft ▪ New output unit: m ▪ New measured value: 0.3 m
Options	<ul style="list-style-type: none"> ▪ % ▪ mm, cm, dm, m ▪ ft, inch ▪ m³, in³ ▪ l, hl ▪ ft³ ▪ gal, lgal ▪ kg, t ▪ lb
Factory setting	%
Height unit	
Write permission	Operator/Maintenance/Expert

Description	Select the height unit. The measured pressure is converted to the selected height unit using the "Adjust density" parameter.
Prerequisite	"Level selection" = In height
Options	<ul style="list-style-type: none"> ■ mm ■ m ■ in ■ ft
Factory setting	m

Calibration mode

Write permission	Operator/Maintenance/Expert
Description	Select the calibration mode.
Options	<ul style="list-style-type: none"> ■ Wet Wet calibration is performed by filling and emptying the vessel. In the event of two different levels, the level, volume, mass or percentage value entered is assigned to the pressure measured at this point in time ("Empty calib." and "Full calib." parameters). ■ Dry Dry calibration is a theoretical calibration. For this calibration, you specify two pressure-level value pairs or height-level value pairs via the following parameters: "Empty calib.", "Empty pressure", "Empty height", "Full calib.", "Full pressure", "Full height".
Factory setting	Wet

Empty calib.

Write permission	Operator/Maintenance/Expert
Description	Enter the output value for the lower calibration point (vessel is empty). The unit defined in "Output unit" must be used.
Note	<ul style="list-style-type: none"> ■ In the case of wet calibration, the level (e.g. vessel empty or partially filled) must actually be available. The associated pressure is then automatically recorded by the device. ■ In the case of dry calibration, the level (vessel empty) does not have to be available. For the "In pressure" level selection, the associated pressure must be entered in the "Empty pressure" parameter. For the "In height" level selection, the associated height must be entered in the "Empty height" parameter.
Factory setting	0.0

Empty pressure

Write permission	Operator/Maintenance/Expert
Description	Enter the pressure value for the lower calibration point (vessel empty). See also "Empty calib."
Prerequisite	<ul style="list-style-type: none"> ■ "Level selection" = In pressure ■ "Calibration mode" = Dry -> entry ■ "Calibration mode" = Wet -> display
Factory setting	0.0

Empty height

Write permission	Operator/Maintenance/Expert
Description	Enter the height value for the lower calibration point (vessel empty). The unit is selected via the "Height unit" parameter.
Prerequisite	<ul style="list-style-type: none"> ■ "Level selection" = In height ■ "Calibration mode" = Dry -> entry ■ "Calibration mode" = Wet -> display
Factory setting	0.0

Full calib.

Write permission	Operator/Maintenance/Expert
Description	Enter the output value for the upper calibration point (vessel full). The unit defined in "Output unit" must be used.
Note	<ul style="list-style-type: none"> ■ In the case of wet calibration, the level (e.g. vessel full or partially filled) must actually be available. The associated pressure is then automatically recorded by the device. ■ In the case of dry calibration, the level (vessel full) does not have to be available. For the "In pressure" level selection, the associated pressure must be entered in the "Full pressure" parameter. The associated height has to be entered in the "Full height" parameter for the "In height" level selection.
Factory setting	100.0

Full pressure

Write permission	Operator/Maintenance/Expert
Description	Enter the pressure value for the upper calibration point (vessel full). See also "Full calib."

Prerequisite

- "Level selection" = In pressure
- "Calibration mode" = Dry -> entry
- "Calibration mode" = Wet -> display

Factory setting URL of the sensor module

Full height

Write permission Operator/Maintenance/Expert

Description Enter the height value for the upper calibration point (vessel full). The unit is selected via the "Height unit" parameter.

Prerequisite

- "Level selection" = In height
- "Calibration mode" = Dry -> entry
- "Calibration mode" = Wet -> display

Factory setting Upper range limit (URL) is converted to a level unit

Density unit

Write permission Maintenance/Expert

Description The measured pressure is converted to a height using the "Height unit", "Adjust density" and "Process density" parameters.

Factory setting g/cm³

Adjust density

Write permission Operator/Maintenance/Expert

Description Enter the density of the medium used to perform the calibration. The measured pressure is converted to a height using the "Height unit" and "Adjust density" parameters.
 Input: Auto dens. corr. = Off
 Display: Auto dens. corr. ≠ Off

Factory setting 1.0

Process density

Write permission Operator/Maintenance/Expert

Description	Enter a new density value for density correction. The calibration was carried out with the medium water, for example. Now the vessel is to be used for another medium with another density. The calibration is corrected appropriately by entering the new density value in the "Process Density" parameter. Input: Auto dens. corr. = Off Display: Auto dens. corr. ≠ Off
Note	If, after completing a wet calibration, you change to dry calibration using the "Calibration mode" parameter, the density for the "Adjust density" and "Process density" parameters must be entered correctly before changing the calibration mode.
Factory setting	1.0

Level before lin.

Write permission	No write permissions. Parameter is read only.
Description	Displays the level value prior to linearization.

14.8 Expert → Measurement → Linearization

Lin. mode

Write permission	Operators/Service engineers/Expert
Description	Select the linearization mode.
Options	<ul style="list-style-type: none"> ▪ Linear The level is output without being converted beforehand. "Level before lin" is output. ▪ Erase table The existing linearization table is deleted. ▪ Manual entry (sets the table to edit mode, an alarm is output): The value pairs of the table (X-value and Y-value) are entered manually. ▪ Semi-automatic entry (sets the table to edit mode, an alarm is output): The vessel is emptied or filled in stages in this entry mode. The device automatically records the level value (X-value). The associated volume, mass or % value is entered manually (Y-value). ▪ Activate table The table entered is activated and checked with this option. The device shows the level after linearization.
Factory setting	Linear

Unit after lin.

Write permission	Operators/Service engineers/Expert
Description	Select volume unit, mass, height or % (unit of the Y-value).
Options	<ul style="list-style-type: none"> ▪ % ▪ cm, dm, m, mm ▪ hl ▪ in³, ft³, m³, ▪ l ▪ in, ft ▪ kg, t ▪ lb ▪ gal ▪ lgal
Factory setting	%

Line-numb

Write permission	Operators/Service engineers/Expert
-------------------------	------------------------------------

Description Enter the number of the current point in the table. Subsequent entries in "X-val" and "Y-val" relate to this point.

Input range 1...32

X-val

Write permission Operators/Service engineers/Expert

Description Enter the X-value (level before linearization) for the specific point in the table and confirm.

Note

- If "Lin. mode" = "Manual", the level value must be entered.
- If "Lin. mode" = "Semiautomatic", the level value is displayed and must be confirmed by entering the paired Y-value.

Y-value

Write permission Operators/Service engineers/Expert

Description Enter the Y-value (value after linearization) for the specific point in the table. The unit is determined by "Unit after lin.".

Note The linearization table must be monotonic (increasing or decreasing).

Edit table

Write permission Operators/Service engineers/Expert

Description Select the function for entering the table.

Options

- Next point: Enter the next point.
- Current point: stay on the current point to correct a mistake for example.
- Last input point: skip back to previous point to correct a mistake for example.
- Insert point: Insert an additional point (see example below).
- Delete point: Delete the current point (see example below).

Example

Add point, in this case between the 4th and 5th point for example

- Select point 5 via the "Line-numb" parameter.
- Select the "Insert point" option via the "Edit table" parameter.
- Point 5 is displayed for the "Line-numb" parameter. Enter new values for the "X-val" and "Y-val" parameters.

Delete point, in this case the 5th point for example

- Select point 5 via the "Line-numb" parameter.
- Select the "Delete point" option via the "Edit table" parameter.
- The 5th point is deleted. All of the following points are pushed up one number i.e. following deletion, the 6th point becomes Point 5.

Factory setting Current point

Tank description

Write permission Operators/Service engineers/Expert

Description Enter the tank description (max. 32 alphanumeric characters)

Tank content

Write permission No write permissions. Parameter is read only.

Description Displays the level value after linearization.

14.9 Expert → Measurement → Sensor limits

LRL sensor

Write permission No write permissions. Parameter is read only.

Description Displays the lower-range limit of the sensor.

URL sensor

Write permission No write permissions. Parameter is read only.

Description Displays the upper-range limit of the sensor.

14.10 Expert → Measurement → Sensor trim

Lo trim measured

Write permission Parameter is read only. Only Endress+Hauser Service has write permission.

Description Displays the reference pressure present to be accepted for the lower calibration point.

Hi trim measured

Write permission Parameter is read only. Only Endress+Hauser Service has write permission.

Description Displays the reference pressure present to be accepted for the upper calibration point.

Lo trim sensor

Write permission No write permissions. Parameter is read only.

Description Sensor module recalibration by entering a target pressure while simultaneously and automatically accepting a reference pressure present for the lower calibration point.

Hi trim sensor

Write permission No write permissions. Parameter is read only.

Description Sensor module recalibration by entering a target pressure while simultaneously and automatically accepting a reference pressure present for the upper calibration point.

14.11 Expert → Output → Current output

Output current

Write permission Operators/Service engineers/Expert

Description Displays the current current value.

Alarm behav. P

Write permission Operators/Service engineers/Expert

Description Configure the response of the current output if sensor module limits are overshoot or undershoot.

Options

- Warning
The device continues to measure. An error message is displayed.
- Alarm
The output signal assumes a value that can be specified by the "Output fail mode" function.

Factory setting Warning

Output fail mode

Write permission Operators/Service engineers/Expert

Description Select Output fail mode. In the event of an alarm, the current assumes the current value specified with this parameter.

Options

- Max: can be set from 21 to 23 mA, see also "High alarm curr."
- Hold: last measured value is held.
- Min: 3.6 mA

Factory setting Max (22 mA)

Max. alarm curr.

Write permission Operators/Service engineers/Expert

Description Enter the current value for maximum alarm current. See also "Output fail mode".

Input range 21 to 23 mA

Factory setting 22 mA

Set min. current

Write permission Operators/Service engineers/Expert

Description Enter lower current limit.
Some switching units accept no current smaller than 4.0 mA.

Options ■ 3.8 mA
 ■ 4.0 mA

Factory setting 3.8 mA

Get LRV

Write permission Operators/Service engineers/Expert

Description Set the lower-range value – reference pressure is present at the device. The pressure for the lower current value (4 mA) is present at the device. Use the "Confirm" option to assign the lower current value to the applied pressure value.

Prerequisite: Pressure measuring mode

Options ■ Cancel
 ■ Confirm

Factory setting Cancel

Set LRV

Write permission Operators/Service engineers/Expert

Description Set the pressure value, level or content for the lower current value (4 mA).

Factory setting ■ 0.0 % in Level measuring mode
 ■ 0.0 mbar/bar or in accordance with ordering information in Pressure measuring mode

Get URV (pressure measuring mode)

Write permission Operators/Service engineers/Expert

Description	Set the upper-range value – reference pressure is present at the device. The pressure for the upper current value (20 mA) is present at the device. Use the "Confirm" option to assign the applied pressure value to the upper current value.
Prerequisite:	Pressure measuring mode
Options	<ul style="list-style-type: none"> ■ Cancel ■ Confirm
Factory setting	Cancel

Set URV

Write permission	Operators/Service engineers/Expert
Description	Set the pressure value, level or content for the upper current value (20 mA).
Factory setting	<ul style="list-style-type: none"> ■ 100.0 % in Level measuring mode ■ URL Sensor or according to ordering information in Pressure measuring mode

Startcurrent

Write permission	Service engineers/Expert
Description	Entry of the start current. This setting also applies in the HART Multidrop mode.
Options	<ul style="list-style-type: none"> ■ 12 mA ■ Max alarm (22 mA, cannot be set)
Factory setting	12 mA

Curr. trim 4mA

Write permission	Service engineers/Expert
Description	Enter the pressure value for the lower point (4 mA) of the current partial regression lines. Using this parameter and "Curr. trim 20 mA", you can adapt the current output to the transmission conditions.
Options	<p>Carry out the current trim for the lower point as follows.</p> <ul style="list-style-type: none"> ■ Select the "Current" option in the "Simulation mode" parameter. ■ In the "Sim current" parameter, configure the "4 mA value". ■ Enter the current value measured using the switching unit in the "Curr. trim 4mA" parameter.
Input range	Measured current ± 0.2 mA

Factory setting 4 mA

Curr. trim 20mA

Write permission Service engineers/Expert

Description Enter the pressure value for the upper point (20 mA) of the current partial regression lines. Using this parameter and "Curr. Trim 4 mA", you can adapt the current output to the transmission conditions.

Options Carry out the current trim for the upper point as follows:

- Select the "Current" option in the "Simulation mode" parameter.
- In the "Sim current" parameter, configure the value "20 mA".
- Enter the current value measured using the switching unit in the "Curr. trim 20mA" parameter.

Input range Measured current ± 1 mA

Factory setting 20 mA

Offset trim 4mA

Write permission Service engineers/Expert

Description Display/enter the difference between 4 mA and the value entered for the parameter "Curr. trim 4mA".

Factory setting 0

Offset trim 20mA

Write permission Service engineers/Expert

Description Display/enter the difference between 20 mA and the value entered for the parameter "Curr. trim 20mA".

Factory setting 0

14.12 Expert → Communication → HART config.

Burst mode

Write permission	Service engineers/Expert
Description	Switching burst mode on and off.
Options	<ul style="list-style-type: none"> ■ On ■ Off
Factory setting	Off

Burst option

Write permission	Service engineers/Expert
Description	You can use this parameter to define which command is sent to the master.
Options	<ul style="list-style-type: none"> ■ 1 (HART command 1) ■ 2 (HART command 2) ■ 3 (HART command 3) ■ 9 (HART command 9) ■ 33 (HART command 33)
Factory setting	1 (HART command 1)

Current mode

Write permission	Service engineers/Expert
Description	Configure current mode for HART communication.
Options	<ul style="list-style-type: none"> ■ Signaling Measured value transmission by the current value ■ Fixed Fixed current 4.0 mA (Multidrop mode) (Measured value transmission via HART digital communication only)
Factory setting	Signaling

Bus address

Write permission	Service engineers/Expert
Description	Use this function to enter the address via which a data exchange is to take place via HART protocol. (HART 5.0 master: Range 0 to 15, where address = 0 calls up the "Signaling" setting; HART 6.0 master: Range 0 to 63)
Factory setting	0

Preamble number

Write permission	Service engineers/Expert
Description	Use this function to enter the number of preambles in the HART protocol. (Synchronization of the modem components along a transmission path, each modem component could "swallow" one byte, at least 2 bytes must be the preamble.)
Input range	2...20
Factory setting	5

14.13 Expert → Communication → HART info

Device type code

Write permission No write permissions. Parameter is read only.

Description Display of the numerical ID of the device
Waterpilot FMX21: 36

Device revision

Write permission No write permissions. Parameter is read only.

Description Display of Device Revision (e.g. 1)

Manufacturer ID

Write permission No write permissions. Parameter is read only.

Description Displays the HART manufacturer ID in a decimal digit format.
Here: 17 (Endress+Hauser)

HART version

Write permission No write permissions. Parameter is read only.

Description Displays HART version .
Waterpilot FMX21: 6

Description

Write permission Service engineers/Expert

Description Enter the tag description (max. 16 alphanumeric characters)

HART message

Write permission	Service engineers/Expert
Description	Enter the message (max. 32 alphanumeric characters) Upon request from the master, this message is sent via the HART protocol.

HART date

Write permission	Service engineers/Expert
Description	Enter the date of the last configuration change.
Factory setting	DD/MM/YY (date of the final test)

14.14 Expert → Communication → HART output

Primary value is

Write permission	No write permissions. Parameter is read only.
Description	Indicates which measured value is transmitted via the HART protocol as the primary process value.
Factory setting	Depending on the selected measuring mode, the following measured values can be displayed: <ul style="list-style-type: none"> ■ "Pressure" measuring mode: "Meas. pressure" ■ "Level" measuring mode, Lin. mode "Linear": "Level before Lin" ■ "Level" measuring mode, Lin. mode "Activate table": "Tank content"

Primary value

Write permission	No write permissions. Parameter is read only.
Description	The primary value is displayed.

Secondary val.is

Write permission	No write permissions. Parameter is read only.
Description	Indicates which measured value is transmitted via the HART protocol as the secondary process value. The process value is configured via HART command 51.
Factory setting	<ul style="list-style-type: none"> ■ "Pressure" measuring mode: "Corrected press." ■ "Level" measuring mode, "Linear" lin. mode: "Meas. pressure" ■ "Level" measuring mode, Lin. mode "Activate table": "Level before linearization"
Display	Depending on the selected measuring mode, the following measured values can be displayed: <ul style="list-style-type: none"> ■ "Meas. pressure" ■ "Sensor pressure" ■ "Corrected press." ■ "Pressure af.damp" ■ "Sensor temp." ■ "Level before Lin" ■ "Tank content" ■ "Process density" (corrected)

Secondary value

Write permission No write permissions. Parameter is read only.

Description The secondary value is displayed.

Third value is

Write permission No write permissions. Parameter is read only.

Description Indicates which measured value is transmitted via the HART protocol as the third process value. The process value is configured via HART command 51.

Factory setting

- "Pressure" measuring mode: "Sensor pressure"
- "Level" measuring mode, "Linear" lin. mode: "Corrected press."
- "Level" measuring mode, "Activate table" lin. mode: "Meas. pressure"

Display Depending on the selected measuring mode, the following measured values can be displayed:

- "Meas. pressure"
- "Sensor pressure"
- "Corrected press."
- "Pressure af.damp"
- "Sensor temp."
- "Level before Lin"
- "Tank content"
- "Process density" (corrected)

Third value is

Write permission No write permissions. Parameter is read only.

Description The third value is displayed.

4th value is

Write permission No write permissions. Parameter is read only.

Description Indicates which measured value is transmitted via the HART protocol as the fourth process value. The process value is configured via HART command 51.

Factory setting

- "Pressure" measuring mode: "Sensor temp"
- "Level" measuring mode, "Linear" lin. mode: "Sensor temp."
- "Level" measuring mode, "Activate table" lin. mode: "Sensor temp."

Display Depending on the selected measuring mode, the following measured values can be displayed:

- "Meas. pressure"
- "Sensor pressure"
- "Corrected press."
- "Pressure af.damp"
- "Sensor temp."
- "Level before Lin"
- "Tank content"
- "Process density" (corrected)

4th value

Write permission No write permissions. Parameter is read only.

Description The fourth value is displayed.

14.15 Expert → Communication → HART input

HART input value

Write permission No write permissions. Parameter is read only.

Description Display of the HART input value

HART input stat.

Write permission No write permissions. Parameter is read only.

Description Display of the HART input status
Bad / Uncertain / Good

HART input unit

Write permission No write permissions. Parameter is read only.

Description Display of the unit for the HART input value.

Display

- Unknown
- mbar, bar
- mmH2O, ftH2O, inH2O
- Pa, hPa, kPa, MPa
- psi
- mmHg, inHg
- Torr
- g/cm², kg/cm²
- lb/ft²
- atm
- °C, °F, K, R

Factory setting Unknown

HART input form.

Write permission Operators/Service engineers/Expert

Description Number of decimal places of the displayed input value.

Options

- x.x
- x.xx
- x.xxx
- x.xxxx
- x.xxxxx

Factory setting

x.x

14.16 Expert → Application

Electr. Delta P

Write permission	Operators/Service engineers/Expert
Description	For switching the Electr. Delta P application off or on with an external or constant value.
Options	<ul style="list-style-type: none"> ■ Off ■ External value ■ Constant
Factory setting	Off

Fixed ext. value

Write permission	Operators/Service engineers/Expert
Description	Use this function to enter the constant value. The value refers to "HART input unit"
Factory setting	0.0

Auto dens. corr.

Write permission	Operators/Service engineers/Expert
Description	<p>For switching the auto dens. corr. application off or on with an external or internal temperature value.</p> <p>Before performing a calibration (dry or wet), auto-density compensation must be switched on if this function is to be used. As soon as "Auto dens. corr." is switched on, the field for entering the "Process density" and "Adjust density" is disabled.</p> <p>The calibration density remains the last value until it is overwritten by a calibration. The process density remains the last value until it is overwritten when the system recalculates the value.</p> <p>Automatic density compensation is performed for the 0 to 70 °C (32 to 158 °F) temperature range. The density values for water are used for this density compensation.</p>
Prerequisite	Level mode
Options	<ul style="list-style-type: none"> ■ Off ■ Sensor temperature ■ External value (only if Off or Constant is selected for Electr. Delta P)
Factory setting	<ul style="list-style-type: none"> ■ Off ■ On (if the option "IC" was selected in the "Service" order code when ordering)

14.17 Expert → Diagnosis

Diagnostic code

Write permission No write permissions. Parameter is read only.

Description Displays the diagnostic message with the highest priority currently present.

Last diag. code

Write permission No write permissions. Parameter is read only.

Description Displays the last diagnostic message that occurred and was rectified.

Note

- Digital communication: the last message is displayed.
- Use the "Reset logbook" parameter to clear the messages listed in the parameter "Last diag. code".

Reset logbook

Write permission Service engineers/Expert

Description Use this parameter to reset all messages of the parameter "Last diag. code" and the event logbook "Last diag. 1" to "Last diag. 10".

Options

- Cancel
- Confirm

Factory setting Cancel

Min. meas. press.

Write permission No write permissions. Parameter is read only.

Description Displays the lowest pressure value measured (peakhold indicator). You can reset this indicator by means of the "Reset peakhold" parameter.

Max. meas. press.

Write permission No write permissions. Parameter is read only.

Description Displays the highest pressure value measured (peakhold indicator). You can reset this indicator by means of the "Reset peakhold" parameter.

Reset peakhold

Write permission Service engineers/Expert

Description You can reset the "Min. meas. press." and "Max. meas. press." indicators with this parameter.

Options

- Cancel
- Confirm

Factory setting Cancel

Operating hours

Write permission No write permissions. Parameter is read only.

Description Displays the hours of operation. This parameter cannot be reset.

Config. counter

Write permission Operators/Service engineers/Expert

Description Displays the configuration counter.
This counter is increased by one every time a parameter or group is changed. The counter counts up to 65535 and then starts again at zero.

14.18 Expert → Diagnosis → Diagnostic list

Diagnostic 1 (075)
Diagnostic 2 (076)
Diagnostic 3 (077)
Diagnostic 4 (078)
Diagnostic 5 (079)
Diagnostic 6 (080)
Diagnostic 7 (081)
Diagnostic 8 (082)
Diagnostic 9 (083)
Diagnostic 10 (084)

Write permission

No write permissions. Parameter is read only.

Description

This parameter contains up to ten diagnosis messages that are currently pending, arranged in order of priority.

14.19 Expert → Diagnosis → Event logbook

Last diag. 1 (085)
Last diag. 2 (086)
Last diag. 3 (087)
Last diag. 4 (088)
Last diag. 5 (089)
Last diag. 6 (090)
Last diag. 7 (091)
Last diag. 8 (092)
Last diag. 9 (093)
Last diag. 10 (094)

Write permission

No write permissions. Parameter is read only.

Description

This parameter contains the last 10 diagnosis messages to occur and be rectified. They can be reset using the "Reset logbook" parameter.
Errors which have occurred multiple times are displayed once only.
Errors may also appear multiple times if another error has occurred in the meantime. The messages are displayed in chronological order.

14.20 Expert → Diagnosis → Simulation

Simulation mode

Write permission

Operators/Service engineers/Expert

Description

Switch on simulation and select the simulation mode. When changing the measuring mode or the "Lin. mode" level type or when the device is restarted, any simulation that may be running is switched off.

Options

- None
- Pressure → see this table, "Sim. pressure" parameter
- Level, → see this table, "Sim. level" parameter
- Tank content, → see this table, "Sim. tank cont." parameter
- Current, → see this table, "Sim. current" parameter
- Alarm/warning, → see this table, "Sim. error no."

Factory setting

None

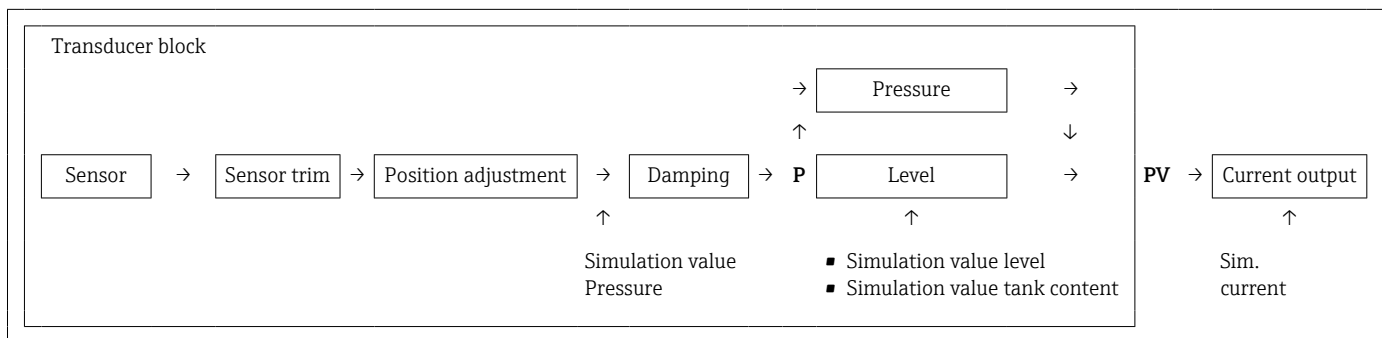

Sim. pressure

Write permission

Operators/Service engineers/Expert

Description

Enter the simulation value. See also "Simulation mode".

Prerequisite

"Simulation mode" = Pressure

Value at switch-on

Current pressure measured value

Sim. level

Write permission

Operators/Service engineers/Expert

Description

Enter the simulation value. See also "Simulation mode".

Prerequisite	"Measuring mode" = Level and "Simulation mode" = Level
Value at switch-on	Current level measured value

Sim. tank cont.

Write permission	Operators/Service engineers/Expert
Description	Enter the simulation value. See also "Simulation mode".
Prerequisite	"Measuring Mode" = level, Lin mode "Activate table" and "Simulation Mode" = Tank content
Value at switch-on	Current tank content



Sim. current

Write permission	Operators/Service engineers/Expert
Description	Enter the simulation value. See also "Simulation mode".
Prerequisite	"Simulation Mode" = Current value
Value at switch-on	Current current value

Sim. alarm/warning

Write permission	Operators/Service engineers/Expert
Description	Enter the simulation value. See also "Simulation mode".
Prerequisite	"Simulation Mode" = Alarm/Warning
Factory setting:	484 (Simulation active)

15 Accessories

- i** ■ Observe the additional information in the individual sections!
- For additional information, see the sections "Mechanical construction" (in the Technical Information), "Environment", →  135, "Process" →  137 and "Mounting" →  15.

15.1 Device-specific accessories

Suspension clamp

For easy installation of the device, Endress+Hauser offers a suspension clamp.

- Product Configurator: the suspension clamp is optionally available
- Order number: 52006151

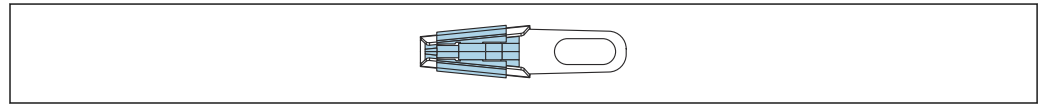

A0030950

Terminal box

Terminal box for terminal strip, temperature head transmitter and Pt100.

- Product Configurator: the terminal box is optionally available
- Order number: 52006152

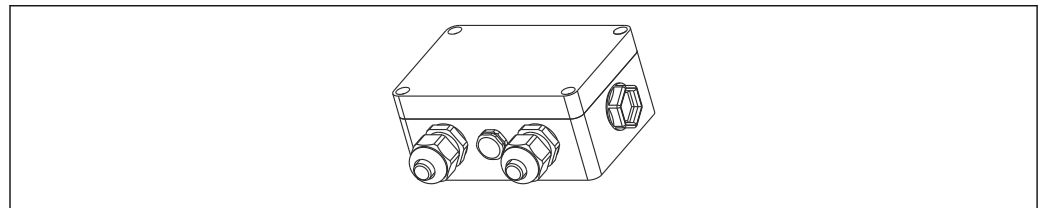

A0030967

4-terminal strip/terminals

4-terminal strip for wiring

Order number: 52008938

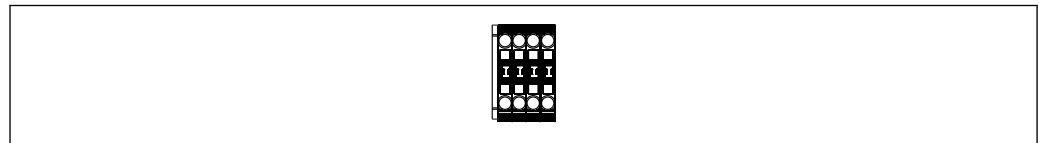

A0030951

Temperature head transmitter TMT71 for FMX21 4 to 20 mA analog

PC-programmable (PCP) temperature head transmitter for the conversion of various input signals.

- Product Configurator: the temperature head transmitter TMT71 is optionally available
→  124
- Order number: 71593573

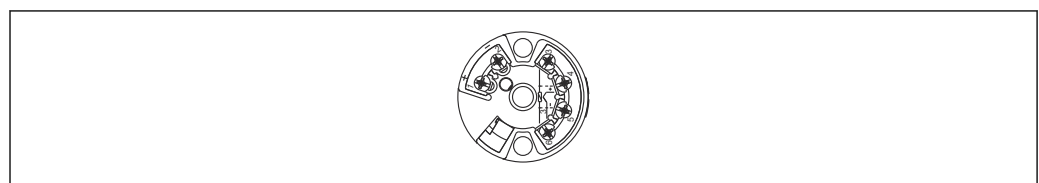

A0030952

Temperature head transmitter TMT72 for FMX21 4 to 20 mA HART

PC-programmable (PCP) temperature head transmitter for the conversion of various input signals.

- Product Configurator: the temperature head transmitter TMT72 is optionally available
- Order number: 71593576

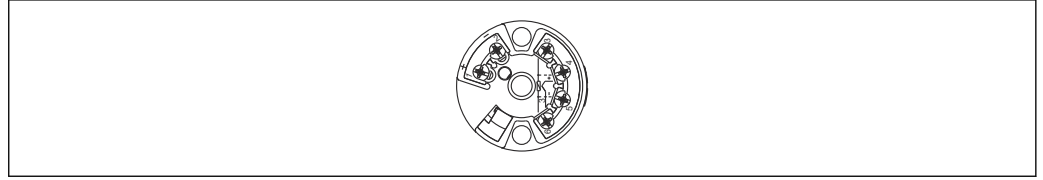

A0030952

Cable mounting screws

Endress+Hauser offers a cable mounting screw for easy device mounting and to seal the measuring aperture.

- G 1½" A
Order number: 52008264
- NPT 1½"
Order number: 52009311
- Product Configurator: the cable mounting screws are optionally available

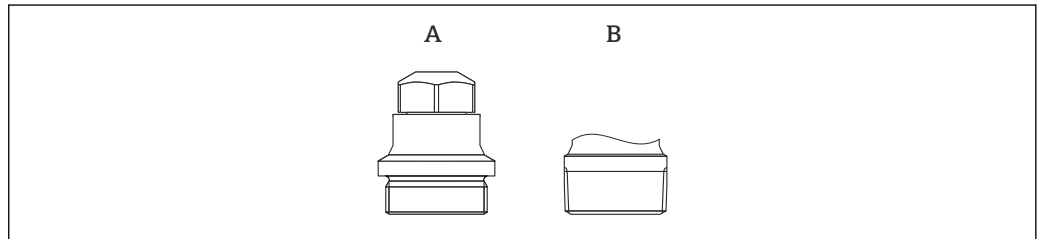

A0030953

- A G 1½" A
B NPT 1½"

Additional weight for device with an outer diameter of 22 mm (0.87 in) or 29 mm (1.14 in)

Endress+Hauser offers additional weights to prevent sideways movement that results in measurement errors, or to make it easier to lower the device in a guide tube.

- Product Configurator: the additional weight is optionally available
- Order number: 52006153

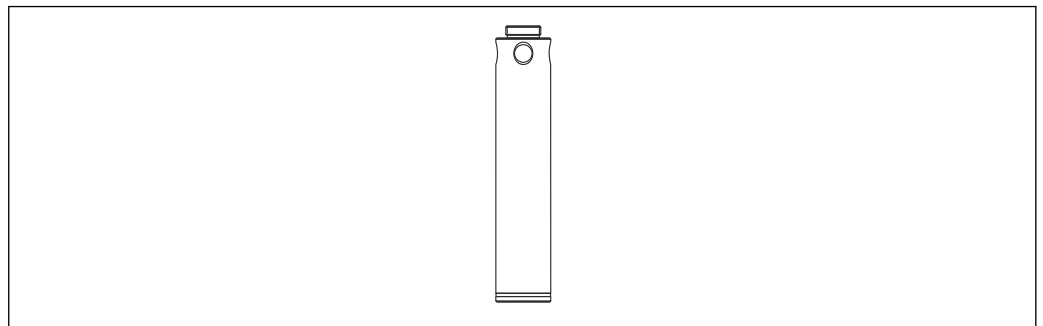

A0030954

Cable shortening kit

The cable shortening kit is used to shorten a cable easily and professionally.

- Product Configurator: the cable shortening kit is optionally available
- Order number: 71222671

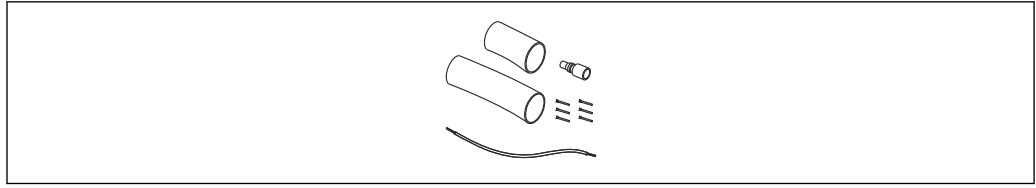

A0030948

Testing adapter for devices with an external diameter of 22 mm (0.87 in) or 29 mm (1.14 in)

Endress+Hauser offers a testing adapter to ease function-testing of the level probes.

- Product Configurator: the testing adapter is optionally available
- Order number: 52011868

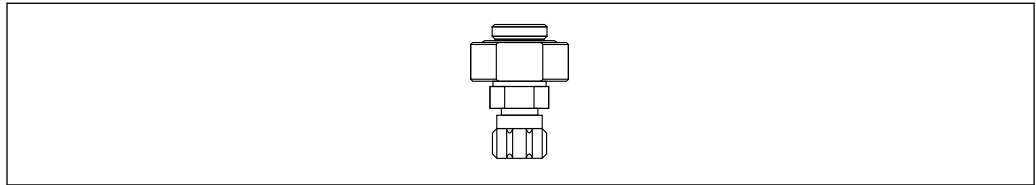

A0030956

Testing adapter for devices with an external diameter of 42 mm (1.65 in)

Endress+Hauser offers a testing adapter to ease function-testing of the level probes.

- Observe the maximum pressure for compressed air hose and maximum overload for level probe
- Maximum pressure for the quick coupling piece provided: 10 bar (145 psi)
- Order number: 71110310

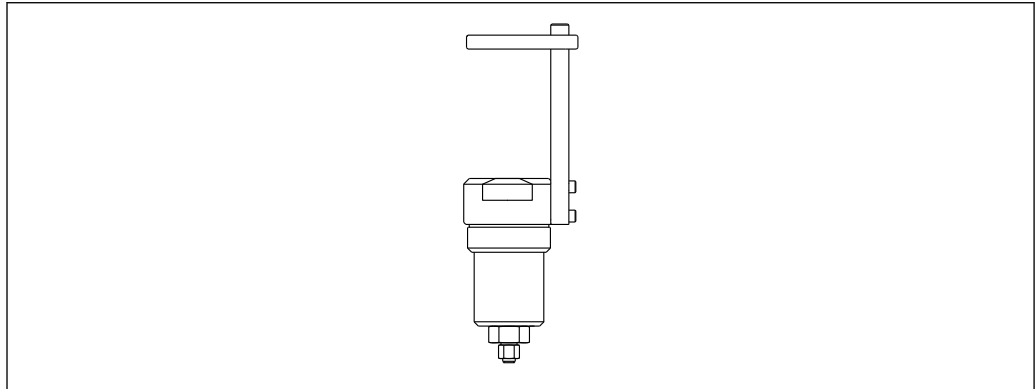

A0030957

RIA15 in the field housing

- Remote display RIA15 non-hazardous
 - ↳ Product structure: the display is optionally available
- Remote display RIA15 hazardous
 - ↳ Product structure: the display is optionally available

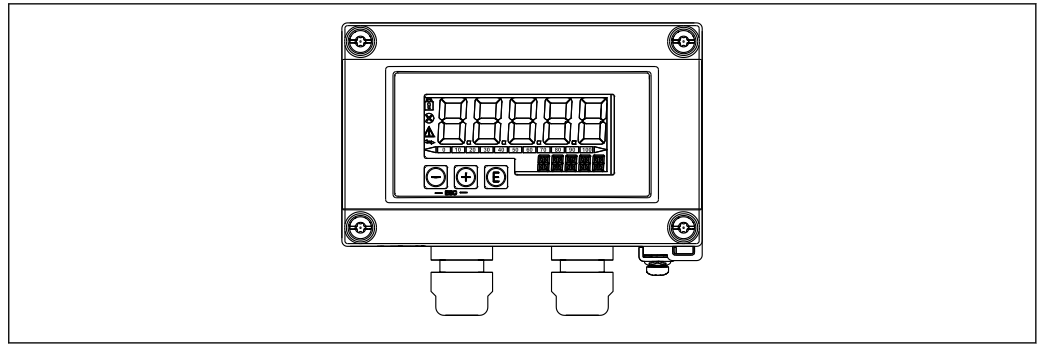

A0036164

HART communication resistor

- HART communication resistor hazardous/non-hazardous area, for use with RIA15
- Product structure: the HART communication resistor is optionally available

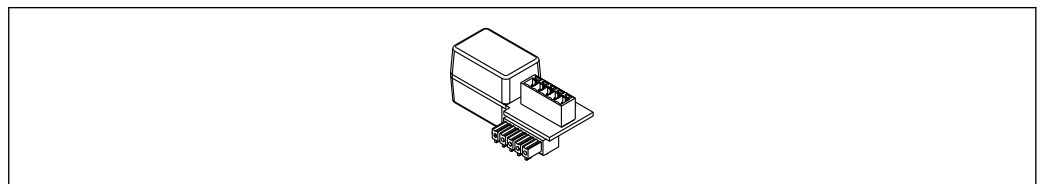

A0036165

15.2 Service-specific accessories

DeviceCare SFE100

DeviceCare is an Endress+Hauser configuration tool for field devices using the following communication protocols: HART, PROFIBUS DP/PA, FOUNDATION Fieldbus, IO/Link, Modbus, CDI and Endress+Hauser Common Data Interfaces.



Technical Information TI01134S

www.endress.com/sfe100

FieldCare SFE500

FieldCare is a configuration tool for Endress+Hauser and third-party field devices based on DTM technology.

The following communication protocols are supported: HART, WirelessHART, PROFIBUS, FOUNDATION Fieldbus, Modbus, IO-Link, EtherNet/IP, PROFINET and PROFINET APL.



Technical Information TI00028S

www.endress.com/sfe500

Applicator

Software for selecting and sizing Endress+Hauser measuring devices:

- Calculation of all the necessary data for identifying the optimum measuring device: e.g. pressure loss, accuracy or process connections.
- Graphic illustration of the calculation results

Administration, documentation and access to all project-related data and parameters over the entire life cycle of a project.

Applicator is available:

<https://portal.endress.com/webapp/applicator>

16 Technical data

16.1 Input

16.1.1 Measured variable

FMX21 + Pt100 (optional)

- Hydrostatic pressure of a liquid
- Pt100: Temperature

TMT72 temperature head transmitter (optional)

Temperature

16.1.2 Measuring range

- Customer-specific measuring ranges or calibration that has been preset in the factory
- Temperature measurement of -10 to +70 °C (+14 to +158 °F) with Pt100 (optional)

Gauge pressure

Sensor measuring range	Lowest calibratable span ¹⁾	Vacuum resistance	Option ²⁾
0.1 bar (1.5 psi)	0.01 bar (0.15 psi)	0.3 bar _{abs} (4.5 psi _{abs})	1C
0.2 bar (3.0 psi)	0.02 bar (0.3 psi)	0.3 bar _{abs} (4.5 psi _{abs})	1D
0.4 bar (6.0 psi)	0.04 bar (1.0 psi)	0 bar _{abs} (0 psi _{abs})	1F
0.6 bar (9.0 psi)	0.06 bar (1.0 psi)	0 bar _{abs} (0 psi _{abs})	1G
1.0 bar (15.0 psi)	0.1 bar (1.5 psi)	0 bar _{abs} (0 psi _{abs})	1H
2.0 bar (30.0 psi)	0.2 bar (3.0 psi)	0 bar _{abs} (0 psi _{abs})	1K
4.0 bar (60.0 psi)	0.4 bar (6.0 psi)	0 bar _{abs} (0 psi _{abs})	1M
10.0 bar (150 psi) ³⁾	1.0 bar (15.0 psi)	0 bar _{abs} (0 psi _{abs})	1P
20.0 bar (300 psi) ³⁾	2.0 bar (30.0 psi)	0 bar _{abs} (0 psi _{abs})	1Q

1) Largest turn down that can be configured at the factory: 10:1, higher turn down can be configured on request or in the device (for FMX21 4 to 20 mA HART).

2) Product Configurator order code for "070"

3) These measuring ranges are not available for the probe version with plastic insulation, outer diameter of 29 mm (1.14 in).

Absolute pressure

Sensor measuring range	Lowest calibratable span ¹⁾	Vacuum resistance	Option ²⁾
2.0 bar (30.0 psi)	0.2 bar (3.0 psi)	0 bar _{abs} (0 psi _{abs})	2K
4.0 bar (60.0 psi)	0.4 bar (6.0 psi)	0 bar _{abs} (0 psi _{abs})	2M
10.0 bar (150 psi) ³⁾	1.0 bar (15.0 psi)	0 bar _{abs} (0 psi _{abs})	2P
20.0 bar (300 psi) ³⁾	2.0 bar (30.0 psi)	0 bar _{abs} (0 psi _{abs})	2Q

1) Largest turn down that can be configured at the factory: 10:1, higher turn down can be configured on request or in the device (for FMX21 4 to 20 mA HART).

2) Product Configurator order code for "070"

3) These measuring ranges are not available for the probe version with plastic insulation, outer diameter of 29 mm (1.14 in).

16.1.3 Input signal

FMX21 + Pt100 (optional)

- Change in capacitance
- Pt100: Change in resistance

TMT72 temperature head transmitter (optional)

Pt100 resistance signal, 4 wire

16.2 Output

16.2.1 Output signal

Device + Pt100 (optional)

- 4 to 20 mA HART with superimposed digital communication protocol HART 6.0, 2-wire for hydrostatic pressure measured value.

Options:

- Max. alarm (factory setting 22 mA): can be set from 21 to 23 mA
- Hold measured value: last measured value is held
- Min. alarm: 3.6 mA
- Pt100: temperature-dependent resistance value

TMT72 temperature head transmitter (optional)

4 to 20 mA HART with superimposed digital communication protocol HART 5.0 for temperature measured value, 2-wire

16.2.2 Signal range

3.8 to 20.5 mA

16.2.3 Maximum load

The maximum load resistance depends on the supply voltage (U) and must be determined individually for each current loop, see formula and diagrams for the device and temperature head transmitter. The total resistance resulting from the resistances of the connected devices, the connecting cable and, where applicable, the resistance of the extension cable may not exceed the load resistance value.

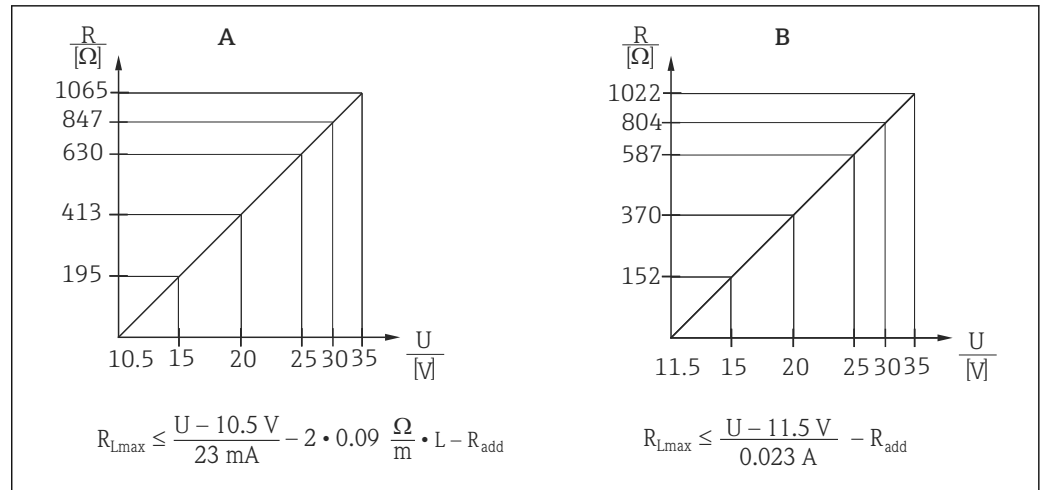

A Load diagram for device 4 to 20 mA HART for an approximate calculation of the load resistance. Additional resistances, such as the resistance of the extension cable, have to be subtracted from the value calculated as shown in the equation.

B Load diagram for TMT72 temperature head transmitter for estimating the load resistance. Additional resistances must be subtracted from the value calculated as shown in the equation

R_{Lmax} Max. load resistance [Ω]

R_{add} Additional resistances such as resistance of evaluating device and/or display unit, cable resistance [Ω]

U Supply voltage [V]

L Basic length of extension cable [m] (cable resistance per wire $\leq 0.09 \Omega/m$)



- When using the measuring instrument in hazardous areas, the applicable national standards and regulations, as well as the safety instructions and Installation or Control Drawings (XA) must be observed.
- When operating via a handheld terminal or via a PC with an operating program, a minimum communication resistance of 250 Ω must be taken into account.

16.2.4 Protocol-specific data

- Manufacturer ID: 17 (11 hex)
- Device type ID: 25 (19 hex)
- Device revision: 01 (01 hex) - SW version 01.00.zz
- HART specification: 6
- DD revision: 01
- Device description files (DTM, DD):
 - www.endress.com
 - www.fieldcommgroup.org
- HART load: min. 250 Ω
- HART device variables. The dynamic variables SV, TV and QV may be assigned to any device variable:
 - Standard process values for SV, TV (second and third device variable) are dependent on the measuring mode: pressure, level
 - Standard process value for QV (fourth device variable) is the sensor temperature: temperature
 - Measured values for PV (first device variable) are dependent on the measuring mode: pressure, level, tank content
- Supported functions:
 - Burst mode
 - Additional transmitter status
 - Device locking
 - Alternative measuring modes
 - Catch variable
 - Long tag

16.3 Performance characteristics

16.3.1 Reference operating conditions

Device + Pt100 (optional)

- As per IEC 60770
- Ambient temperature T_A = constant, in the range of: +21 to +33 °C (+70 to +91 °F)
- Humidity φ = constant, in the range of: 20 to 80 % rH
- Atmospheric pressure p_A = constant, in the range of:
860 to 1060 mbar (12.47 to 15.37 psi)
- Position of the measuring cell constant, vertical in the range of $\pm 1^\circ$
- Input of LOW SENSOR TRIM and HIGH SENSOR TRIM for lower range value and upper range value (only for HART)
- Supply voltage constant: 21 to 27 V_{DC}
- Load: 250 Ω
- Pt100: DIN EN 60770, $T_A = +25^\circ\text{C}$ (+77 °F)

TMT72 temperature head transmitter (optional)

Calibration temperature: +25 °C (+77 °F) ± 5 K

16.3.2 Reference accuracy

Device + Pt100 (optional)

The reference accuracy comprises the non-linearity after limit point configuration, hysteresis and non-reproducibility in accordance IEC 60770.

Standard version:

Setting ± 0.2 %

- to TD 5:1: < 0.2 % of set span
- from TD 5:1 to TD 20:1 $\pm(0.02 \times \text{TD} + 0.1)$

Platinum version:

- Setting ± 0.1 % (optional)
 - to TD 5:1: < 0.1 % of set span
 - from TD 5:1 to TD 20:1 $\pm(0.02 \times \text{TD})$
- Class B as per DIN EN 60751
Pt100: max. ± 1 K

TMT72 temperature head transmitter (optional)

- ± 0.2 K
- With Pt100: max. ± 0.9 K

16.3.3 Resolution

Current output: 1 μA

Reading cycle

HART commands: on average 2 to 3 per second

16.3.4 Long-term stability

Device + Pt100 (optional)

- ≤ 0.1 % of URL/year
- ≤ 0.25 % of URL/5 years

TMT72 temperature head transmitter (optional)

≤ 0.1 K per year

16.3.5 Influence of medium temperature

- Thermal change in the zero output and the output span:
 - 0 to 30 °C (+32 to 86 °F): $< (0.15 + 0.15 \times \text{TD})\%$ of set span
 - 10 to +70 °C (+14 to 158 °F): $< (0.4 + 0.4 \times \text{TD})\%$ of set span
- Temperature coefficient (T_K) of the zero output and the output span
 - 10 to +70 °C (+14 to 158 °F): 0.1 % / 10 K of URL

16.3.6 Warm-up time

Device + Pt100 (optional)

- Device: < 6 s
- Pt100: 300 s

TMT72 temperature head transmitter (optional)

4 s

16.3.7 Response time

Device + Pt100 (optional)

- Device: 400 ms (T90 time), 500 ms (T99 time)
- Pt100: 160 s (T90 time), 300 s (T99 time)

16.4 Environment

16.4.1 Ambient temperature range

Device + Pt100 (optional)

- With external diameter of 22 mm (0.87 in) and 42 mm (1.65 in):
-10 to +70 °C (+14 to +158 °F) (= medium temperature)
- With external diameter of 29 mm (1.14 in):
0 to +50 °C (+32 to +122 °F) (= medium temperature)

Cables

(when mounted in a fixed position)

- With PE: -30 to +70 °C (-22 to +158 °F)
- With FEP: -40 to +70 °C (-40 to +158 °F)
- With PUR: -40 to +70 °C (-40 to +158 °F)

Terminal box

-40 to +80 °C (-40 to +176 °F)

TMT72 temperature head transmitter (optional)

-40 to +85 °C (-40 to +185 °F)

Temperature head transmitter 2-wire, configured for a measuring range of -20 to +80 °C (-4 to +176 °F). This configuration allows the temperature range of 100 K to be displayed with good resolution. Note that the Pt100 resistance thermometer is suitable for a temperature range of -10 to +70 °C (14 to +158 °F)

 The TMT72 temperature head transmitter is not designed for use in hazardous areas incl. CSA GP.

16.4.2 Storage temperature range

Device + Pt100 (optional)

-40 to +80 °C (-40 to +176 °F)

Cable

(when mounted in a fixed position)

- With PE: -30 to +70 °C (-22 to +158 °F)
- With FEP: -30 to +80 °C (-22 to +176 °F)
- With PUR: -40 to +80 °C (-40 to +176 °F)

Terminal box

-40 to +80 °C (-40 to +176 °F)

TMT72 temperature head transmitter (optional)

-40 to +100 °C (-40 to +212 °F)

16.4.3 Degree of protection

Device + Pt100 (optional)

IP68, permanently hermetically sealed at 20 bar (290 psi) (~200 m H₂O)

Terminal box (optional)

IP66, IP67

TMT72 temperature head transmitter (optional)

IP00, condensation permitted

16.4.4 Electromagnetic compatibility (EMC)**Device + Pt100 (optional)**

- EMC in accordance with all relevant requirements of EN 61326 series. For details, refer to the Declaration of Conformity.
- Maximum deviation: < 0.5 % of span.

TMT72 temperature head transmitter (optional)

EMC in accordance with all relevant requirements of EN 61326 series. For details, refer to the Declaration of Conformity.

16.5 Process

16.5.1 Medium temperature range

Device + Pt100 (optional)

- With external diameter of 22 mm (0.87 in) and 42 mm (1.65 in):
-10 to +70 °C (+14 to +158 °F)
- With external diameter of 29 mm (1.14 in):
0 to +50 °C (+32 to +122 °F)

TMT72 temperature head transmitter (optional)

-40 to +85 °C (-40 to +185 °F)

(= ambient temperature), install temperature head transmitter outside the medium.

Temperature head transmitter 2-wire, configured for a measuring range of -20 to +80 °C (-4 to +176 °F). This configuration offers a temperature range of 100 K which can be displayed with good resolution. Please note that the Pt100 resistance temperature detector is suitable for a temperature range of -10 to +70 °C (14 to +158 °F)

 The TMT72 temperature head transmitter is not designed for use in hazardous areas incl. CSA GP.

16.5.2 Medium temperature limit

Device + Pt100 (optional)

With external diameter of 22 mm (0.87 in) and 42 mm (1.65 in):
-20 to +70 °C (-4 to +158 °F)

 In hazardous areas incl. CSA GP, the medium temperature limit is -10 to +70 °C (+14 to +158 °F).

With external diameter of 29 mm (1.14 in): 0 to +50 °C (+32 to +122 °F)

 The FMX21 may be operated in this temperature range. The specification values, such as measurement accuracy, may be exceeded.

16.5.3 Process pressure range

Pressure specifications

 The maximum pressure for the device depends on the lowest-rated element with regard to pressure.

Components are: process connection, optional mounting parts, or accessories.

⚠ WARNING**Incorrect design or use of the device may cause injury due to bursting parts!**

- ▶ Only operate the device within the specified limits for the components!
- ▶ MWP (maximum working pressure): The maximum working pressure is specified on the nameplate. This value refers to a reference temperature of +20 °C (+68 °F) and may be applied to the device for an unlimited time. Note temperature dependence of MWP.
- ▶ The overpressure limit is the maximum pressure that a device may be subjected to during a test. The overpressure limit exceeds the maximum working pressure by a certain factor.
- ▶ The Pressure Equipment Directive (2014/68/EU) uses the abbreviation "PS". The abbreviation "PS" corresponds to the MWP (maximum working pressure) of the device.
- ▶ The Pressure Equipment Directive (2014/68/EU) uses the abbreviation "PT". The abbreviation "PT" corresponds to the OPL (Over Pressure Limit) of the device. OPL (Over Pressure Limit) is a test pressure.
- ▶ In the case of measuring cell range and process connection combinations where the overpressure limit (OPL) of the process connection is less than the nominal value of the measuring cell, the device is set at the factory, at the very maximum, to the OPL value of the process connection. If the full measuring cell range is to be used, select a process connection with a higher OPL value.
- ▶ Avoid steam hammering! Steam hammering can cause zero point drift.
Recommendation: Residue (water droplets or condensation) may remain on the process membrane following CIP cleaning and can result in local steam hammering the next time steam cleaning takes place. Drying the process membrane (e.g. by blowing off excess moisture) has proven effective in avoiding steam hammering.

16.6 Additional technical data

See Technical Information TI00431P.

Index

0 ... 9

4th value	114
4th value is	113

A

Adjust density	97
Alarm behav. P	104
Applications	10
Auto dens. corr.	117

B

Burst Mode	108
Burst Option	108
Bus Address	108

C

Calib. offset	41
Calib. Offset	90
Calibration mode	95
CE mark	11
Cleaning	76
Code definition	86
Config. counter	119
Configuration of a level measurement	44
Configuration of a pressure measurement	42
Configure measuring mode	39
Configuring level measurement	44
Configuring pressure measurement	42
Configuring the pressure engineering unit	40
Corrected press.	93
Curr. trim 4mA	106
Curr. trim 20mA	107
Current Mode	108
Cust. tag number	87

D

Damping	41, 90
Declaration of Conformity	11
Density correction	117
Density unit	97
Description	110
Device replacement	77
Device revision	110
Device tag	87
Device type code	110
DeviceCare	33
Diagnostic 1 (075)	120
Diagnostic 2 (076)	120
Diagnostic 3 (077)	120
Diagnostic 4 (078)	120
Diagnostic 5 (079)	120
Diagnostic 6 (080)	120
Diagnostic 7 (081)	120
Diagnostic 8 (082)	120
Diagnostic 9 (083)	120
Diagnostic 10 (084)	120
Diagnostic code	118

Diagnostic event	68
Diagnostic event in RIA15	68
Diagnostic events	67
Diagnostic message	67
Diagnostics	
Symbols	67
Disposal	77

E

Edit table	100
Electr. Delta P	117
Electr. serial no.	88
Empty calib.	95
Empty height	96
Empty pressure	95
ENP version	88
Enter reset code	89
Event text	68
Ext. order code	87
Exterior cleaning	76

F

Fault identification	67
Firmware Version	87
Fixed ext. value	117
Full calib.	96
Full height	97
Full pressure	96

G

Get LRV	105
Get URV (pressure measuring mode)	105

H

HART Date	111
HART input form.	115
HART input stat.	115
HART input unit	115
HART input val.	115
HART Message	110
HART version	110
HART® protocol	
Operating tools	37
Process variables	37
Version data for the device	37
Height unit	94
Hi trim measured	103
Hi trim sensor	103

I

Intended use	10
--------------	----

L

Last diag. 1 (085)	121
Last diag. 2 (086)	121
Last diag. 3 (087)	121
Last diag. 4 (088)	121

Last diag. 5 (089)	121
Last diag. 6 (090)	121
Last diag. 7 (091)	121
Last diag. 8 (092)	121
Last diag. 9 (093)	121
Last diag. 10 (094)	121
Last diag. code	118
Level before lin.	98
Level selection	94
Lin. mode	99
Line-numb.	99
Lo trim measured	103
Lo trim sensor	103
Local display see Diagnostic message see In alarm condition	
LRL sensor	102
M	
Maintenance	76
Manufacturer ID	110
Max. alarm curr.	104
Max. meas. press.	118
Media	10
Menu Overview	78, 81
Parameter description	86
Min. meas. press.	118
O	
Offset trim 4mA	107
Offset trim 20mA	107
Operating hours	119
Operating menu Overview	78, 81
Parameter description	86
Operating mode	89
Operational safety	10
Operator code	86
Order Identifier	88
Output current	104
Output fail mode	104
Output unit	94
P	
Pos. zero adjust	90
Preamble Number	109
Press. eng. unit	91
Pressure af.damp	93
Pressure measured	92
Primary value	112
Primary value is	112
Process density	97
Product safety	11
R	
Repair concept	77
Replacing a device	77
Requirements for personnel	10
Reset Logbook	118

Reset Peakhold	119
Return	77

S

Safety Instructions (XA)	7
Safety requirements Basic	10
Secondary val. is	112
Secondary value	112
Sensor pressure	92
Sensor serial no.	88
Sensor temp.	91
Serial number	87
Set LRV	92, 105
Set min. current	105
Set URV	92, 106
Sim. alarm/warning	123
Sim. current	123
Sim. level	122
Sim. pressure	122
Sim. tank cont.	123
Simulation mode	122
Spare parts	77
Nameplate	77
Startcurrent	106
Status signals	67

T

Tank content	101
Tank description	101
Temp. Eng. Unit	91
Third value	113
Third value is	113

U

Unit after lin.	99
URL sensor	102
Use of measuring instruments Borderline cases	10
Incorrect use	10
Use of the measuring instrument see Intended use	

W

W@M Device Viewer	77
Workplace safety	10

X

X-value	100
-------------------	-----

Y

Y-value	100
-------------------	-----



71762963

www.addresses.endress.com
