

Technical Information

Gamma Modulator FHG65

Synchronizer FHG66

Radiometric Level Measurement



Effective Suppression of Background Radiation and Extraneous Radiation at the Gammapilot M FMG60

Application

- **Gamma Modulator FHG65**
Improving the measurement results of radioactive measurement through the effective suppression of background radiation and extraneous radiation (e.g. from nondestructive material testing) at the Gammapilot FMG60
- **Synchronizer FHG66**
Synchronization of an unlimited number of Gamma Modulators FHG65 and operating status display for easy diagnosis of the modulators FHG65.

Your benefits

- Unhindered measurement with Gammapilot M FMG60 in the event of
 - Interference radiation from nondestructive material testing up to 50 $\mu\text{Sv/h}$
 - Fluctuating background radiation
- Easy integration into existing systems
- No maintenance required
- Easy installation in conjunction with FQG61/62 source containers





Table of contents

Document information	3
Symbols	3
Function and system design	4
System Design	4
System requirements at Gammapilot M FMG60	4
Gamma Modulator FHG65	4
Synchronizer FHG66	5
Cascading multiple Synchronizers FHG66	6
Gamma Modulator FHG65	7
Technical data	7
Electrical connection	9
Installation	10
Mounting multiple Gamma Modulators FHG65	11
Mounting at diagonally irradiated pipes	12
Water cooling	12
Mechanical construction	13
Ordering information	16
Synchronizer FHG66	17
Technical data	17
Electrical connection	19
Installation	20
Mechanical construction	21
Human interface	22
Ordering information	23
Certificates and approvals	24
CE mark	24
Explosion protection	24
Other approvals	24
Overspill protection	24
Other standards and guidelines	24
Documentation	24
Gamma Modulator FHG65, Synchronizer FHG66	24
FQG61/FQG62 source containers	24
Gamma emitter FSG60/FSG61	24
Gammapilot M FMG60	24

Document information

Symbols



Safety symbols

Symbol	Meaning
 <small>A0011189-DE</small>	DANGER! This symbol alerts you to a dangerous situation. Failure to avoid this situation will result in serious or fatal injury.
 <small>A0011190-DE</small>	WARNING! This symbol alerts you to a dangerous situation. Failure to avoid this situation can result in serious or fatal injury.
 <small>A0011191-DE</small>	CAUTION! This symbol alerts you to a dangerous situation. Failure to avoid this situation can result in minor or medium injury.
 <small>A0011192-DE</small>	NOTICE! This symbol contains information on procedures and other facts which do not result in personal injury.



Electrical symbols

Symbol	Meaning
 <small>A0018339</small>	Protective ground connection A terminal which must be connected to ground prior to establishing any other connections.

Symbols for certain types of information

Symbol	Meaning
 <small>A0011182</small>	Allowed Indicates procedures, processes or actions that are allowed.
 <small>A0011184</small>	Forbidden Indicates procedures, processes or actions that are forbidden.
 <small>A0015484</small>	Reference to page Refers to the corresponding page number.

Symbols in graphics

Symbol	Meaning
1, 2, 3, 4, ...	Item numbers
1., 2., ...	Series of steps
A, B, C, D, ...	Views
 <small>A0011187</small>	Hazardous area Indicates a hazardous area.
 <small>A0011188</small>	Safe area (non-hazardous area) Indicates a non-hazardous location.

Function and system design

System Design

A measuring point with the Gamma Modulator FHG65 consists of the following components:

- Gamma Modulator FHG65
- Gammapilot M FMG60
- Radiation Source Container FQG61 or FQG62
- Radiation source ^{137}Cs or ^{60}Co
- If multiple Gamma Modulators are used or to diagnose: Synchronizer FHG66

System requirements at Gammapilot M FMG60

In order to be able to evaluate the signal created by the Gamma Modulator FHG65, the Gammapilot M FMG60 must be equipped with at least one of the following software versions:

- HART electronics
 - For SIL devices of short level limit detectors (200 mm or 400 mm): SW 01.02.02 or higher
 - For all other device types: SW 01.03.02 or higher
- PROFIBUS PA electronics
 - SW 01.03.02 or higher
- FOUNDATION Fieldbus electronics
 - SW 01.03.02 or higher

Gamma Modulator FHG65

In a radiometric measuring point with Gammapilot FMG60, the Gamma Modulator FHG65 is mounted in front of the radiation exit channel of the source container. It contains a shaft slotted along the longitudinal axis. This shaft rotates continuously and alternately screens off the gamma beam at a frequency of 1 Hz or allows it through.

Due to this frequency, the useful beam differs from fluctuating ambient interference radiation and from interference radiation occurring sporadically (e.g. from nondestructive material testing). Using a frequency filter, the Gammapilot M FMG60 can thus separate the useful signal from interference radiation. In this way, it is possible to continue measuring even if interference radiation occurs, which, in turn, increases the measuring certainty and system availability.

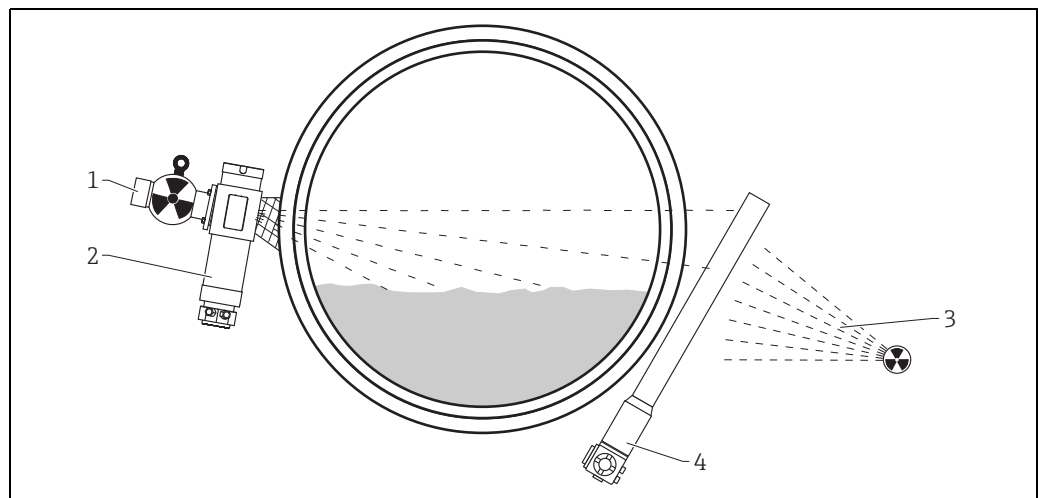

- 1 FQG61, FQG62
 2 FHG65
 3 Interference radiation
 4 Gammapilot M FMG60

A0018245

NOTICE

The Gamma Modulator FHG65 and the Gammapilot M FMG60 are not interconnected electrically. When commissioning the Gammapilot FMG60, the "beam type" (*02) parameter must be set to "modulated".

Synchronizer FHG66

In a measuring point with multiple radiation sources, a Gamma Modulator FHG65 has to be mounted on every source container. The Synchronizer FHG66 synchronizes the individual modulators to common mode. A Synchronizer FHG66 can synchronize up to three Gamma Modulators FHG65. (For more than 3 modulators refer to → 6)

In addition, the Synchronizer offers a straightforward diagnostic solution for the connected FHG65 modulators, which is also of benefit when only one FHG65 modulator is in operation.

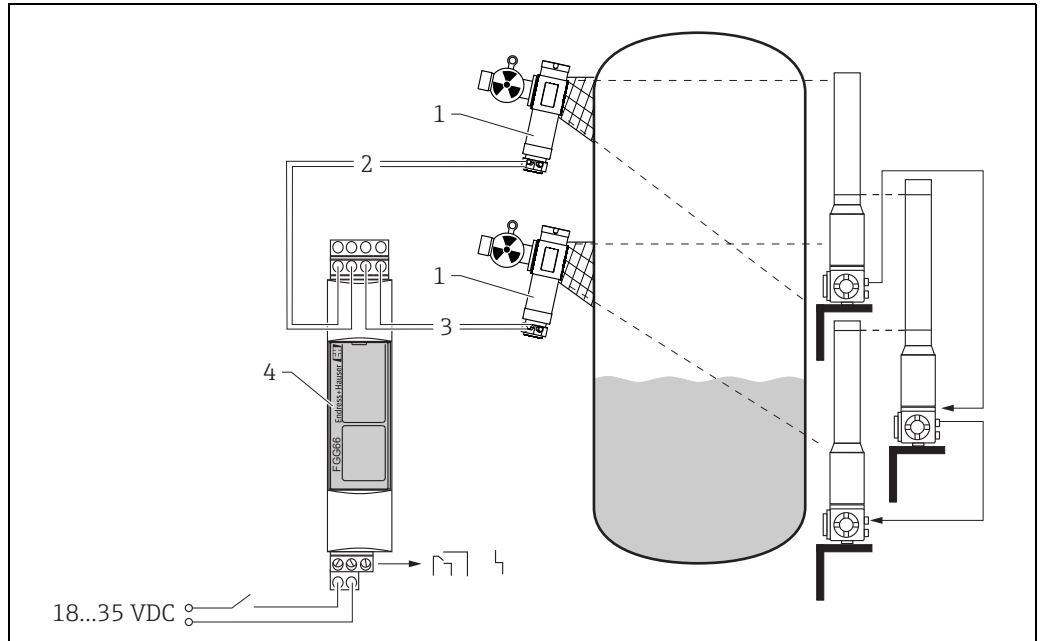

- 1 FHG66
- 2 FHG65

NOTICE

It is recommended to install the switch for the supply voltage in the proximity of the instrument and to mark it as a disconnecter for the instrument.

NOTICE

For minimum point level detection, use of the FHG66 Synchronizer, in particular of its alarm output, is recommended due to the fact that an undetected error in the FHG65 modulator may result in faulty switching behavior.

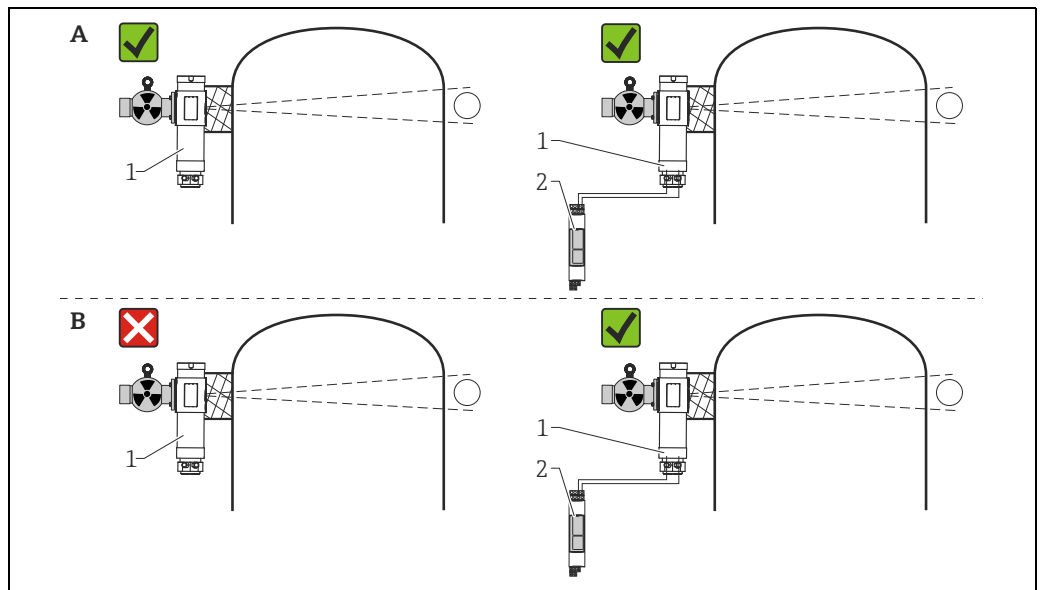

- A Maximum point level detection
- B Minimum point level detection

- 1 FHG65
- 2 FHG66

Cascading multiple Synchronizers FHG66

If more than three radiation sources are used, the synchronization chain must be extended by cascading, where another Synchronizer (3) is connected to one of the outputs of the Synchronizer (2) instead of a modulator.

All connected Gamma Modulators then operate in common mode. By interconnecting this cascading function, any number of modulators can be synchronized with one another.

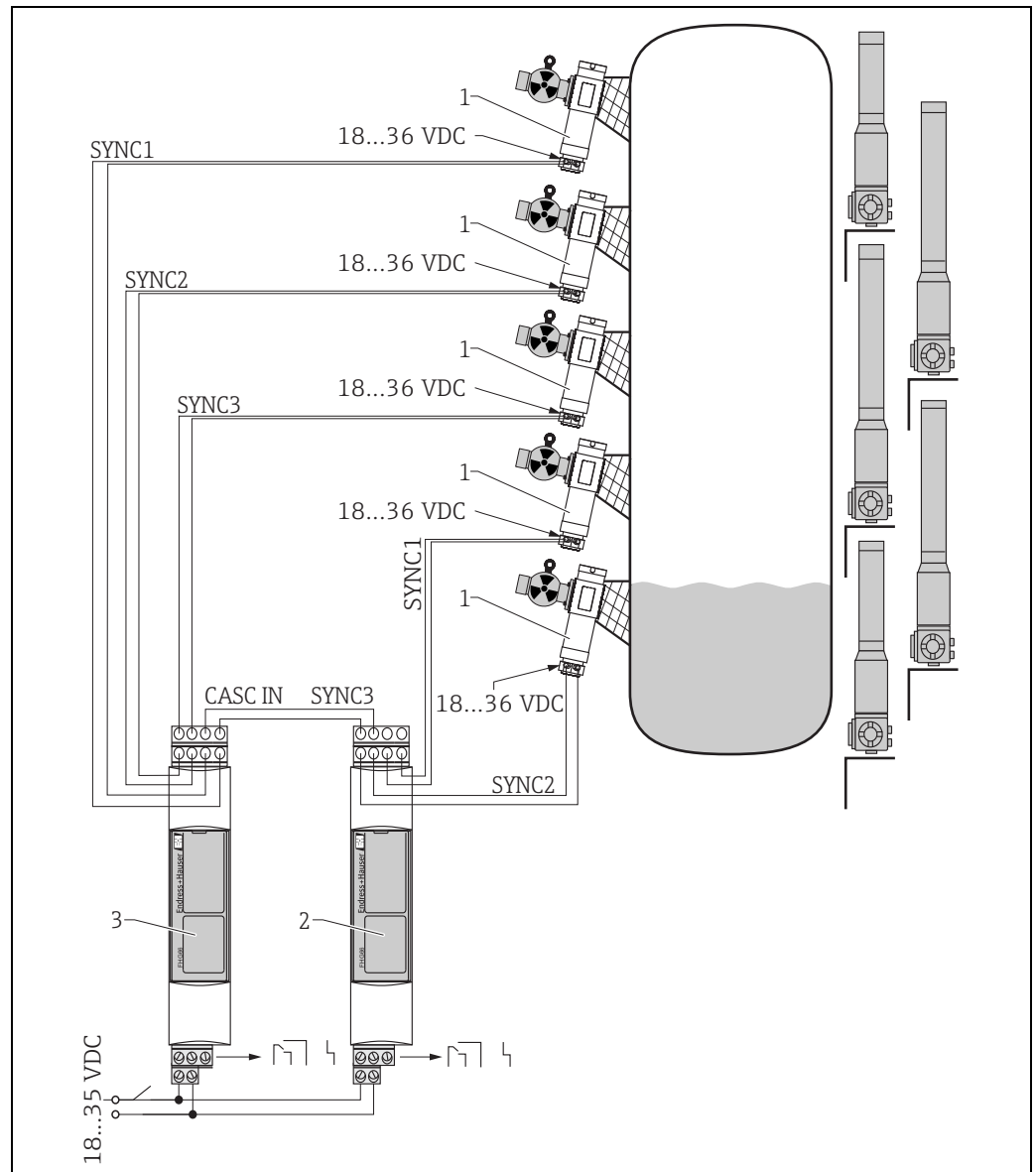

A0018541

- 1 FHG65
- 2 Primary Synchronizer
- 3 Cascaded Synchronizer

Gamma Modulator FHG65

Technical data

Power supply

Supply voltage	18 to 36 VDC
Power consumption	3.2 W
Overtoltage category	II
Protection class	1
Potential equalization	Present

Alarm output

The Gamma Modulator FHG65 does not have an alarm output of its own. Errors are indicated in the following way:

- If a Synchronizer FHG66 is connected:
The error is reported via the synchronization terminals to the Synchronizer FHG66. The alarm relay of the FHG66 indicates the error.
- If no Synchronizer FHG66 is connected:
In the case of an error, the FHG65 switches its motor off. This reduces the current consumption to less than 30 mA, which can be detected and indicated by an external current monitoring device (e.g. Dold IK9076.11, DC24V, < 0.1 A).

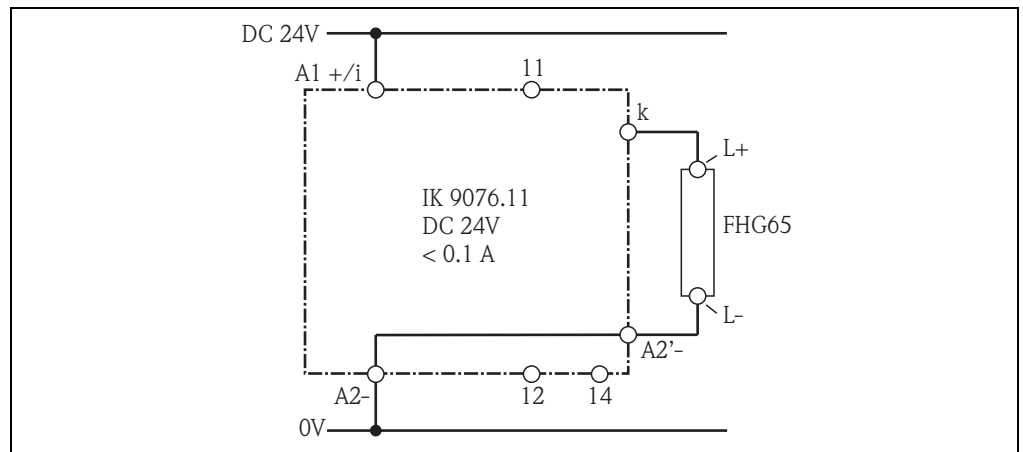

A0018539

Environment

Ambient temperature range	<ul style="list-style-type: none"> ■ Without water cooling: -40 to +60 °C (-40 to +140 °F) ■ With water cooling: <ul style="list-style-type: none"> - at the water cooling jacket: 0 to +120 °C (32 °F to +248 °F) - at the terminal housing: max. +75 °C (+167 °F)
Storage temperature	-40 to +75 °C (-40 to +167 °F)
Housing degree of protection	IP66/67; TYPE 4X/6
Climate class	DIN EN 60068-2-38 examination Z/AD
Vibration resistance	DIN EN 60068-2-64 test Fh; 10 to 2000 Hz, 1 (m/s ²) ² /Hz
Shock resistance	DIN EN 60068-2-27; test Ea; 30 g, 18 ms, 3 shocks/direction/axis
Electromagnetic compatibility	Interference emission to EN 61326, Appendix A (Industrial) and NAMUR Recommendation NE21

Interference suppression

Max. 10 $\mu\text{S/h}$ per 1000 mm (39.4 in) measuring length

Measuring range [mm (in)]	Maximum interference suppression [$\mu\text{Sv/h}$]
200 (7.87)	50
800 (31.5)	12.5
2000 (78.7)	5
10000 (394) - cascading	1

Electrical connection

Connection compartment

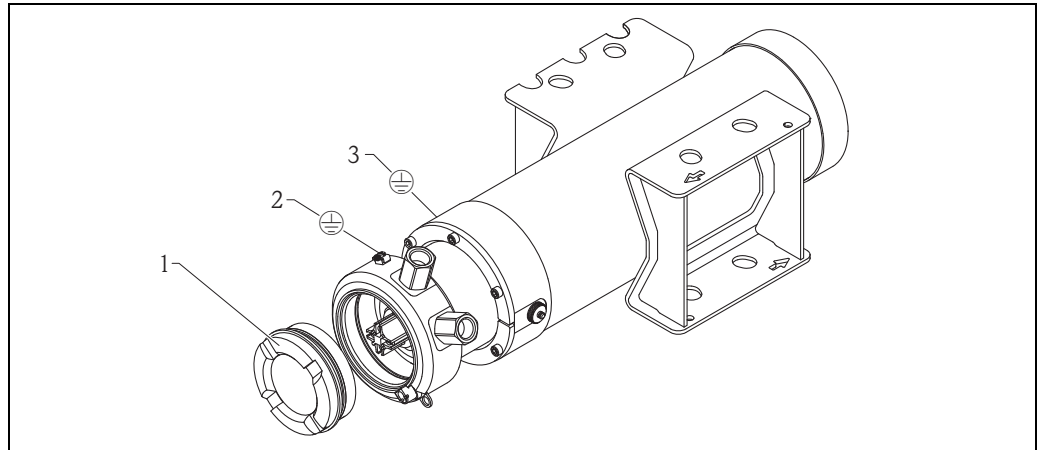

- 1 Cover of the connection compartment
- 2 Ground terminal of the modulator
- 3 Ground terminal of the water cooling jacket

Cable entries

2 cable entries (for supply voltage and synchronization connection). Versions:

- M20 gland
- M20 thread
- G ½ thread
- NPT ½ thread

Terminal assignment

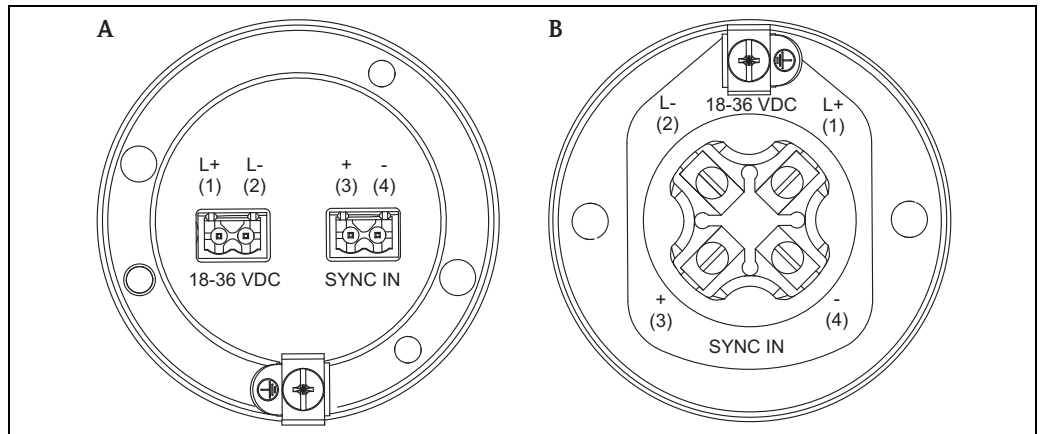

- A Ex d, Ex t, non-Ex - version
- B Ex de - version

Terminal	Name	Meaning
1	L+	Supply voltage; 18 to 36 VDC
2	L-	
3	SYNC +	Synchronization connection (to connect the Synchronizer FHG66) 12 VDC, 5 mA
4	SYNC -	

- Install a circuit breaker in the supply line.
- Use wires of $\geq 0.5 \text{ mm}^2$ (20 AWG) cross section.
- The flag of the ground connector has to be mounted in the direction indicated in the figure.

Installation

General installation conditions

- The Gamma Modulator FHG65 is mounted directly on the mounting flange of the FQG61 or FQG62 source container.¹⁾

⚠ CAUTION

It is absolutely essential to ensure the device is oriented correctly when mounting since the radiation exit channel is not located in the middle of the source container. The arrow on the mounting plate of the Gamma Modulator must point in the direction of the transporting lug of the source container. Measurement is not possible otherwise.

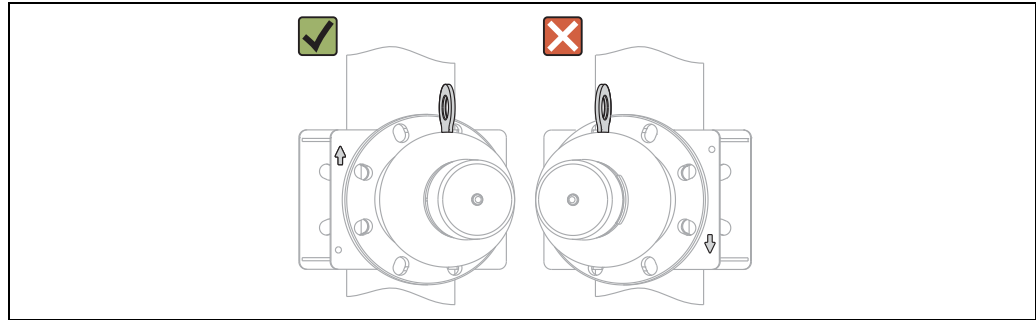

A0018532

- The source container together with the Gamma Modulator must be mounted as close as possible to the tank or measuring tube.
- The unit must be mounted on a low-vibration construction.
- Use at least 4 threaded bolts (M16);
Torque:
 - Steel: 210 Nm (154.88 lbf ft)
 - Stainless Steel: 144 Nm (106.20 lbf ft)
- When mounting, attention must be paid to the total weight consisting of the source container and Gamma Modulator FHG65. Ensure sufficient stability is guaranteed. Where necessary, an additional support must be provided.
- After mounting, the local dose rate in the vicinity of the source container and the Gamma Modulator must be measured. Any control zones must be cordoned off, see TI00435F/00 (FQG61/FQG62)
- Through to the use of the Modulator the effective useful horizontal radiation beam angle is reduced from 6° to 2°.
 - ▶ Please check if detector is completely covered by the radiation beam.

1) For applications with the FQG66 source container: please contact your local Endress+Hauser sales office.

**Mounting multiple
Gamma Modulators FHG65**

If multiple Gamma Modulators FHG65 are used in a measuring point, they have to run synchronously. The Synchronizer FHG66 is used for this purpose.

NOTICE

The synchronization requires that all the Gamma Modulators FHG65 be aligned the same. A mark is provided at the top of the Gamma Modulator FHG65 to align the units. This mark must be aligned in the same way relative to the source container on all the participating Gamma Modulators FHG65.

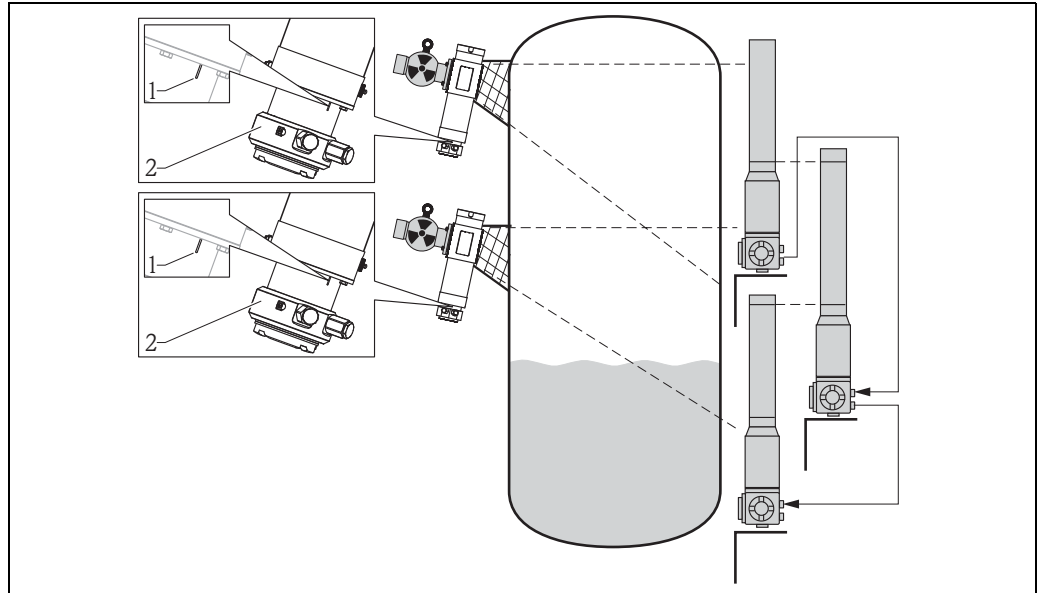

- 1 Marking for aligning multiple Gamma Modulators
This mark must be aligned in the same way relative to the source container on all the Gamma Modulators in a measuring point.
- 2 FHG65

A0018533

Mounting at diagonally irradiated pipes

With diagonally irradiated pipes the clamping device FHG61 must be used for mounting. For details see Mounting Instructions KA00261F/00.

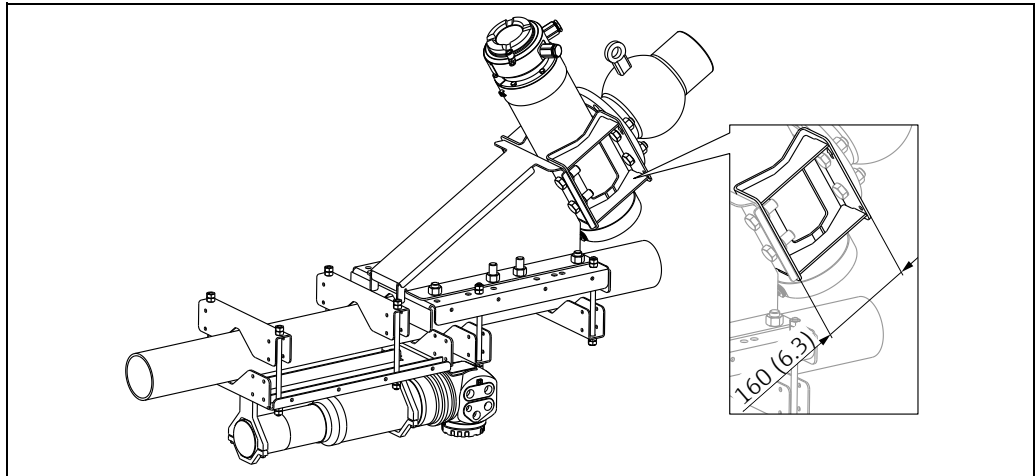

A0018534

Dimensions: mm (in)

Water cooling

The following applies to the FMG60 Gamma Modulator with water cooling:

- Material: 316L and 304
- Water connection: 2 x G 1/4"A, DIN ISO 228
- Return temperature: max. 40 °C (104 °F); temperature monitoring recommended
- Water pressure: 4 to 6 bar (58 to 87 psi)
- Water flow rate: min. 60 l/h
- Drain sensor with cooling tube or protect against freezing.

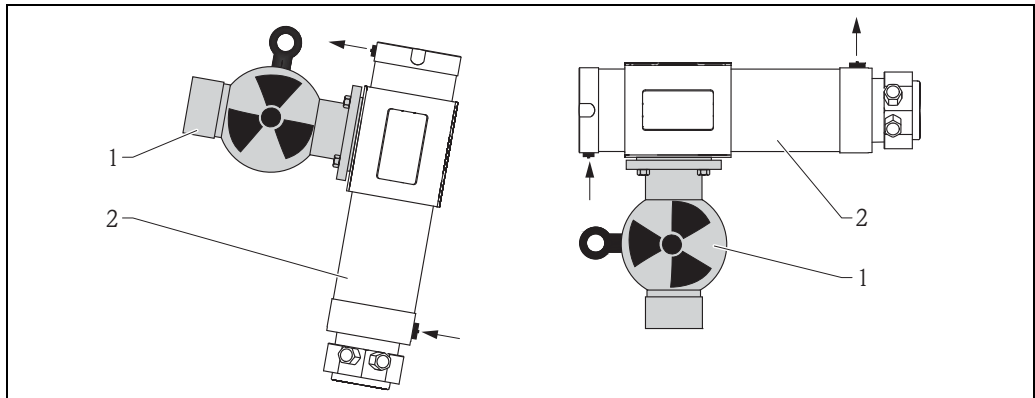

A0018535

- 1 FQG61, FQG62
- 2 FHG65

⚠ CAUTION

The water must always be let in from the bottom to ensure that the water jacket is completely filled.

Mechanical construction

Dimensions Gamma Modulator

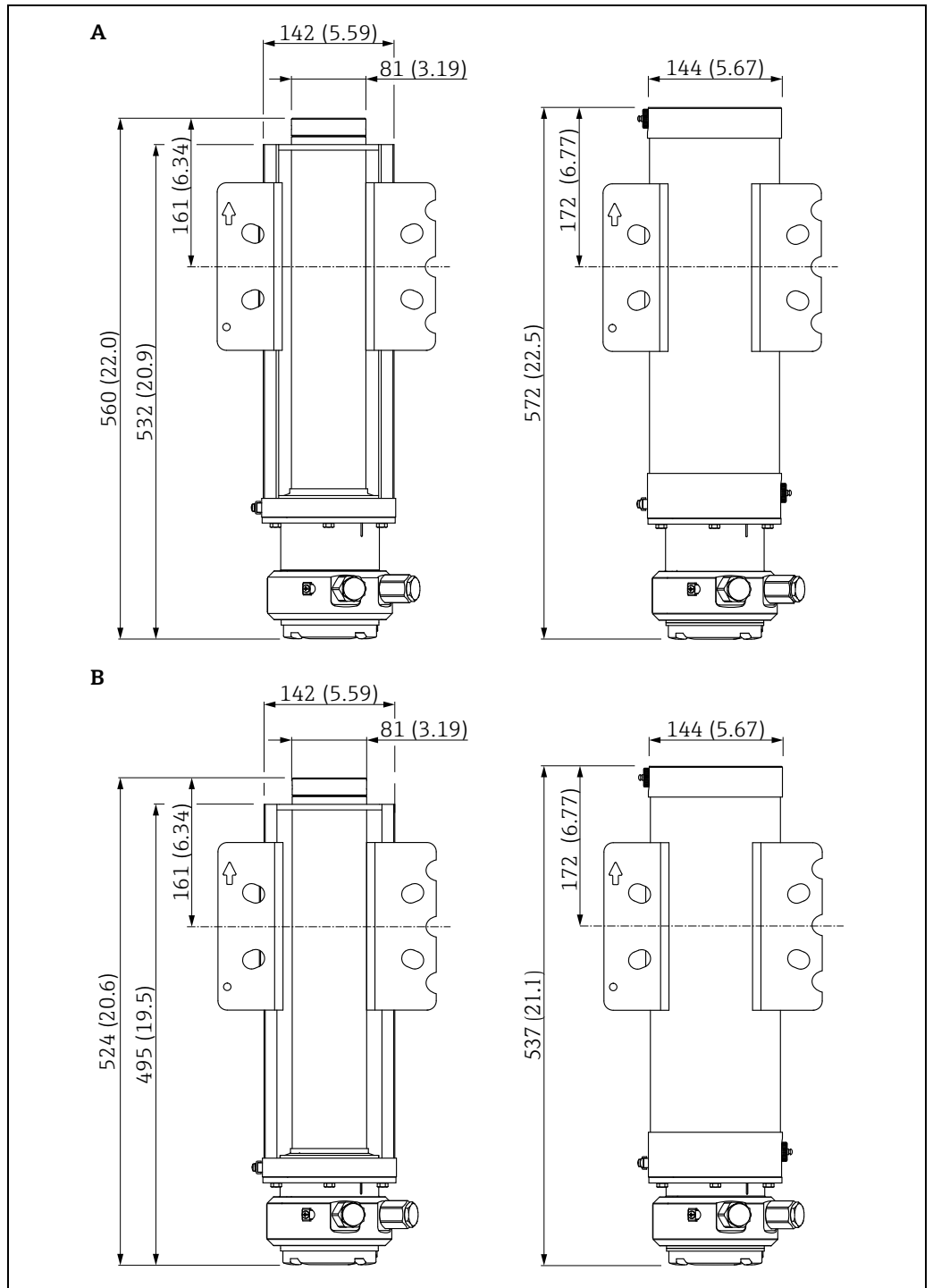

A0018530

Dimensions: mm (in)

A Ex de - version (left: without water jacket; right: with water jacket)

B Ex d, Ex t, non-Ex - version (left: without water jacket; right: with water jacket)

Examples of mounting brackets (supplied by customer)

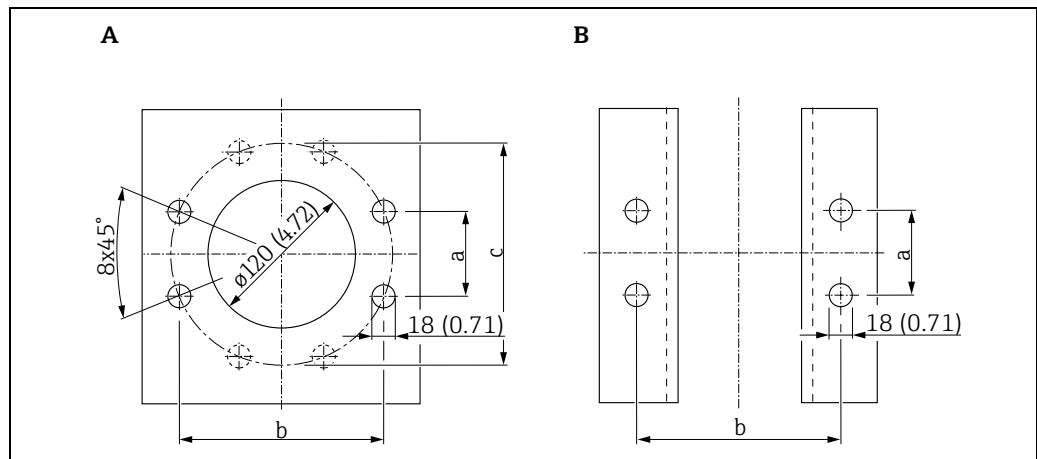

Dimensions: mm (in)

A Mounting plate (Bolt circle according to DN 100 PN 16 or ANSI 4" 150 psi)

B L profile

Weight

- Without water cooling jacket: max. 18 kg (39.69 lbs)
- With water cooling jacket (empty): max. 21 kg (46.31 lbs)
- With water cooling jacket (full): max. 25 kg (55.13 lbs)

Durability of the bearings

36 years at maximum load in continuous operation.

Material

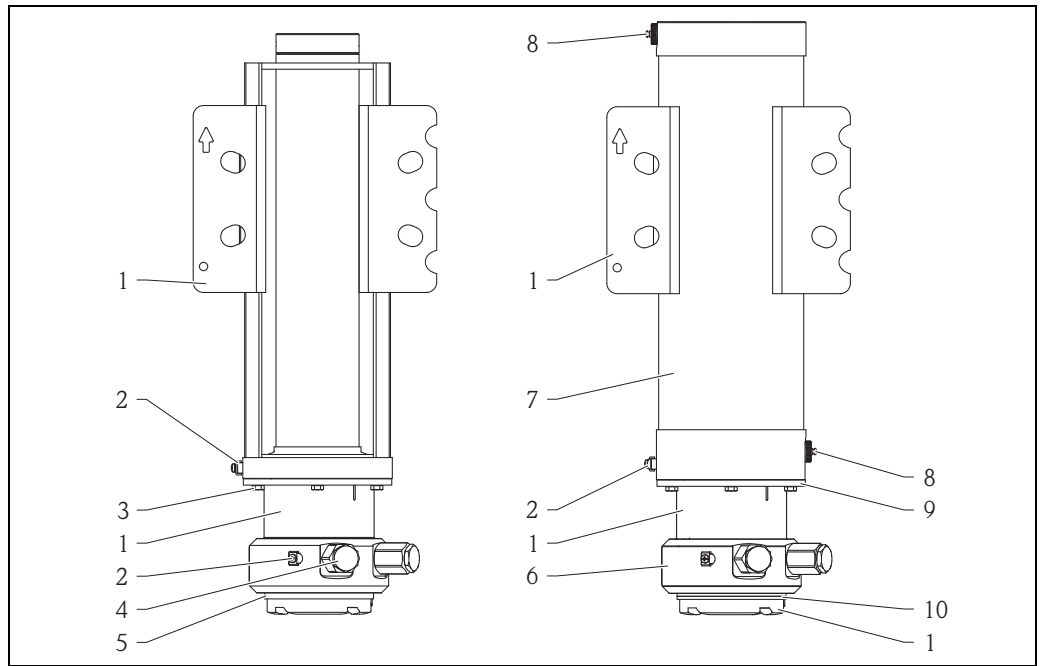

A0018555

Number	Part	Material
1	Housing	304 (1.4301)
2	Ground terminal	316Ti (1.4571); 304 (1.4301); A2 ; A4
3	Screws	A2-70
4	O-ring	FKM 70
5	Cable entry	see table below
6	Nameplate and grooved pins	304 (1.4301); A2
7	Water cooling jacket	316L (1.4404)
8	Cooling water connection	PA66
9	O-ring	FKM 70
10	Safety pin for the lid	304 (1.4301); 1.4581 ; A2

Material of cable entry and seal

Feature 040: "Cable entry, power supply"	316L (1.4404/1.4435)	12L13 (1.0718)	304 (1.4301)	MS	EPDM70+PTFE
A: M20 gland	✓	✓		✓	✓
B: M20 thread	✓	✓			✓
C: G 1/2 thread	✓	✓	✓		✓
D: NPT 1/2 thread		✓	✓		✓

Ordering information

Detailed ordering information is available from the following sources:

- In the Product Configurator on the Endress+Hauser website: www.endress.com → Select your country → Products → Select measuring technology, software or components → Select the product (picklist: measurement method, product family etc.) → Device support (right-hand column): Configure the selected product → The Product Configurator for the selected product opens
- From your Endress+Hauser Sales Center: www.addresses.endress.com

**Product Configurator - the tool for individual product configuration**

- Up-to-the-minute configuration data
- Depending on the device: Direct input of measuring point-specific information such as measuring range or operating language
- Automatic verification of exclusion criteria
- Automatic creation of the order code and its breakdown in PDF or Excel output format
- Ability to order directly in the Endress+Hauser Online Shop

Synchronizer FHG66

Technical data

Input

Cascading input

- For connection of an additional Synchronizer FHG66
- Galvanically isolated from power supply and output
- Connecting cable: twin-core; shielding not required (apart from in the event of strong electromagnetic interference)
- Cable requirements:
 - Max. capacitance: 120 nF
 - Max. resistance 1000 Ω
 - Max. inductance: 0.65 mH
 - Cable: not shielded/not twisted
- Signal transmission: closed current loop with 0 to 5 mA, max. 12 V

Output

Alarm relay

Type	Floating changeover contact
Switching delay	0 to 3 s
Switching capacity	<ul style="list-style-type: none"> ■ U~ maximum 250V ■ I~ maximum 2 A ■ P~ maximum 500 VA at $\cos\phi \geq 0.7$ ■ U- maximum 40 V ■ I- maximum 2 A ■ P- maximum 80 W
Operating life	Min. 10^5 switching cycles with maximum contact load
Function indicator	Light emitting diodes for operation, faults and error assignment; device detects and reports errors in the configuration and in the connected devices
Overvoltage category	II
Protection class	2 (double/reinforced insulation)

Signal on alarm

- Fault indicated by red LED
- Fault assigned by yellow LEDs
- Alarm relay deenergized

Power supply

Supply voltage	18 to 35 VDC (power supply with safe isolation required)
Power consumption	≤ 1 W
Overvoltage category	II
Protection class	2
Contamination level	2

Environment

Ambient temperature range	<ul style="list-style-type: none"> ▪ Mounted individually: -20 to +60 °C (-4 to +140 °F) ▪ Mounted in a row without lateral spacing: -20 to +50 °C (-4 to +122 °F) ▪ When installed in protective housing: -20 to +40 °C (-4 to +104 °F)
Storage temperature	-20 to +85 °C (-4 to +185 °F) (preferably at 20 °C (68 °F))
Climate and mechanical application class	<ul style="list-style-type: none"> ▪ 3C3 in accordance with DIN EN 60721-3-3 ▪ 3M2 in accordance with DIN EN 60721-3-3
Degree of protection	IP20 Mechanical degree of protection IK06 (1J) according to IEC 62262
Electromagnetic compatibility	<ul style="list-style-type: none"> ▪ Interference emission to EN 61326, class B equipment ▪ Interference immunity to EN 61326, Appendix A (Industrial) and NAMUR Recommendation NE 21

Installation

Mounting location

The Synchronizer FHG66 must be housed in a cabinet outside the hazardous area and protected against mechanical influences. If mounting outdoors, a protective housing (min. IP65) must be used.

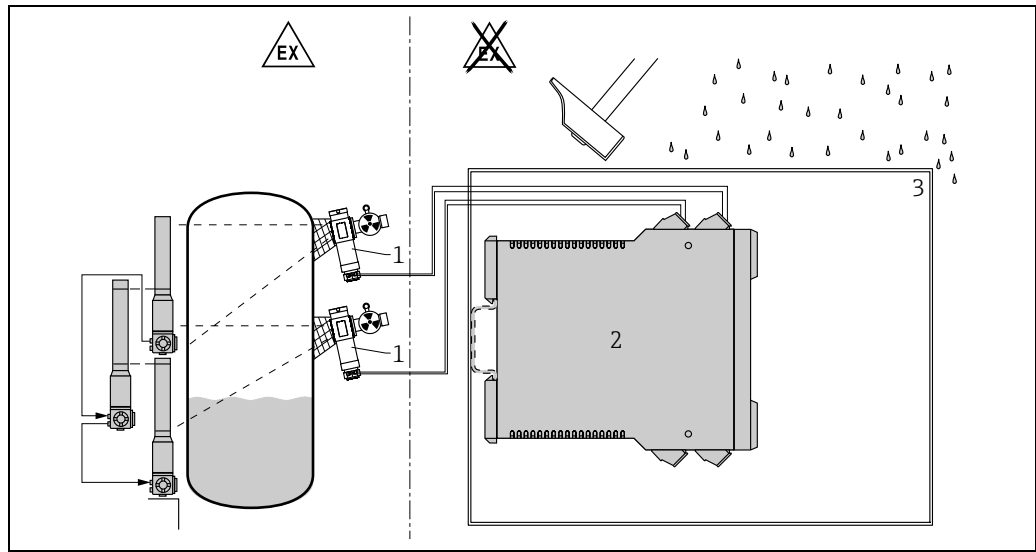

- 1 FHG65
2 FHG66
3 min. IP65

CAUTION

Observe the following conditions:

- ▶ Mechanical degree of protection for FHG66: see "Technical data", → 17
- ▶ The ventilation slots of the housing must not be blocked

Installation instructions

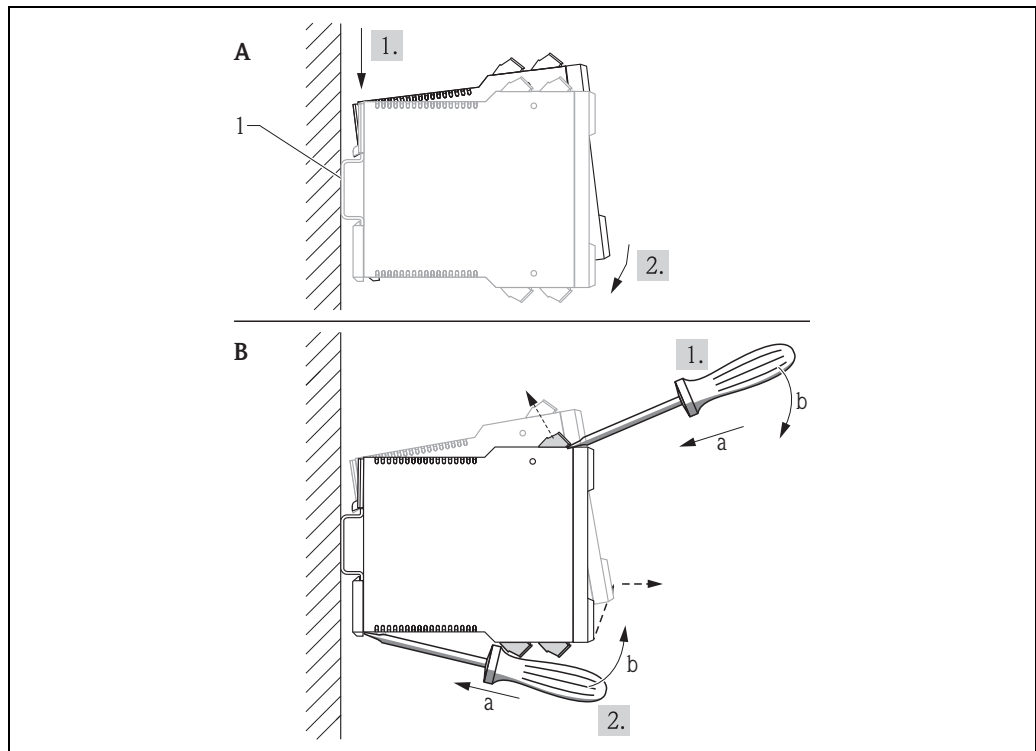

- A Mounting on top-hat rail
B Disassembly (1. Remove terminal blocks; 2. Remove device)

Mechanical construction

Dimensions

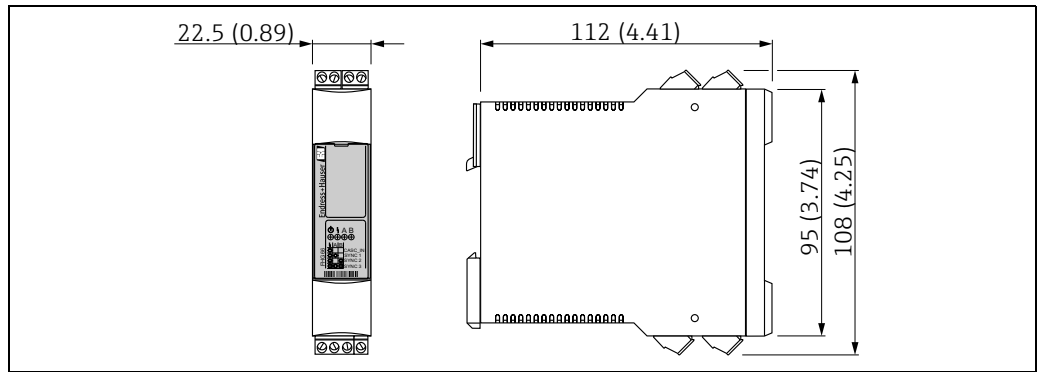

Dimensions: mm (in)

A0018543

Weight

Approx. 150 g (5.291 oz)

Material

Part	Material
Housing	Polycarbonate
Front cover	Polyamide PA6
Fixing slide (to secure to top-hat rail)	Polyamide PA6

Human interface

Display elements

LEDs are visible when the front panel is closed.

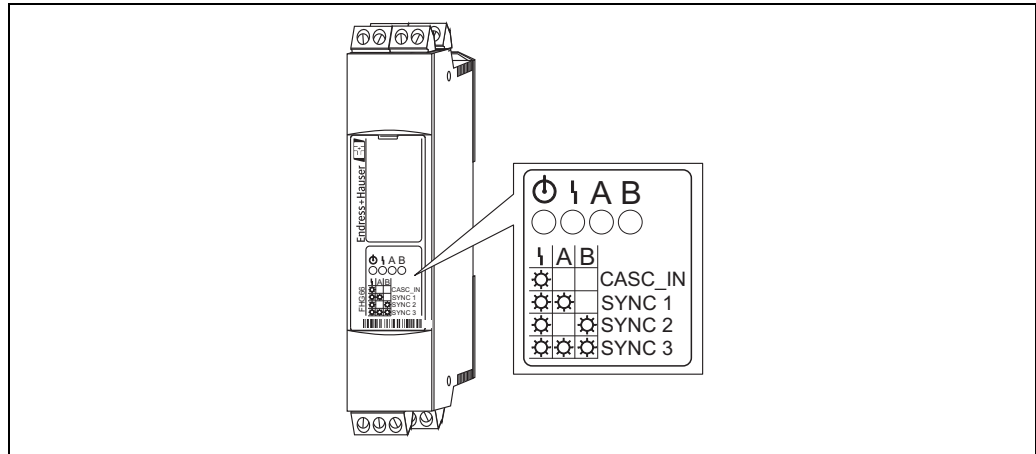

A0018547

LED	Color	Meaning
⏻	Green	Operational Is lit as soon as the supply voltage is switched on.
⚡	Red	Error Is lit if an error is present at one of the synchronization outputs or the cascading input.
A,B	Yellow	Error identifier Indicates the synchronization output where the error is present: <ul style="list-style-type: none"> ▪ A: Error at SYNC 1 ▪ B: Error at SYNC 2 ▪ A and B: Error at SYNC 3 ▪ A and B off, but red LED lit: Error at the cascading input (CASC_IN)

Operating elements

DIP switches are behind the swing-back front panel.

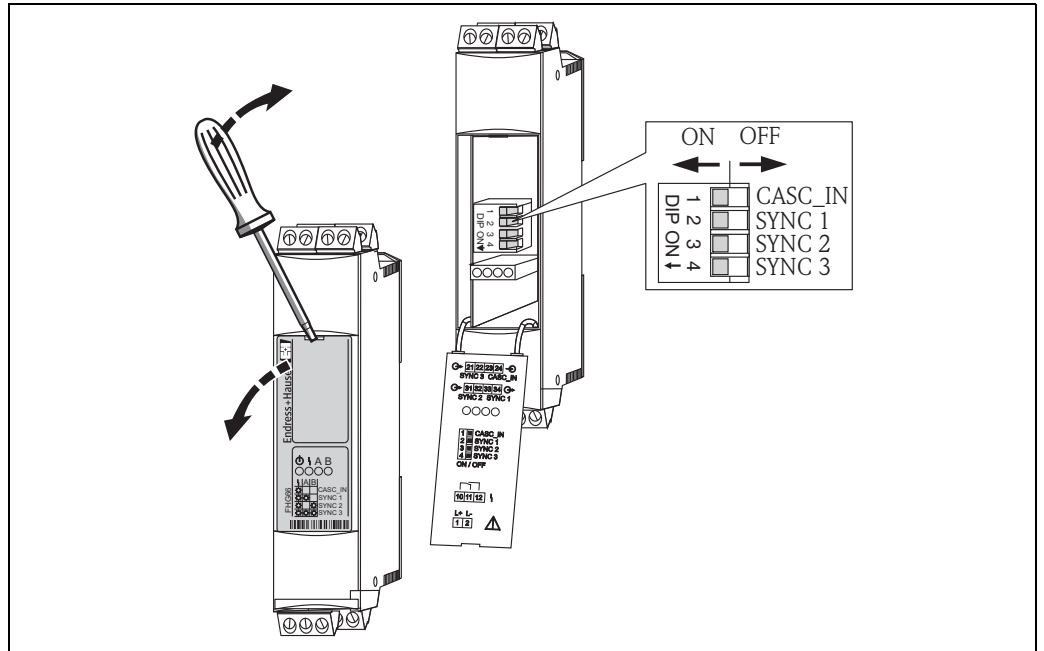

A0018548

The DIP switches are used to switch the synchronization outputs and the cascading input on and off in accordance with the diagram above.

DIP switches	Input/output
1	Cascading input (terminals 23/24)
2	Synchronization output 1 (terminals 33/34)
3	Synchronization output 2 (terminals 31/32)
4	Synchronization output 3 (terminals 21/22)

Ordering information

Order code: 71060806

Certificates and approvals

CE mark	The measuring system meets the legal requirements of the EC Directives. Endress+Hauser confirms successful testing of the device by affixing to it the CE mark.
Explosion protection	Gamma Modulator FHG65
Other approvals	Synchronizer FHG66 CSA GP
Overspill protection	<ul style="list-style-type: none"> ▪ May be applied in max-level applications in connection with the Gammapilot M FMG60 (200/400 mm) in SIL 2/3 according to IEC 61508. ▪ Not tested for overspill protection according to WHG
Other standards and guidelines	<p>IEC 60529 Degrees of protection by housing (IP code)</p> <p>IEC 61326 Electromagnetic compatibility (EMC requirements)</p> <p>IEC 61010 Protection measures for electrical equipment for measurement, control, regulation and laboratory procedures.</p> <p>NAMUR Association for Standards for Control and Regulation in the Chemical Industry</p>

Documentation

Gamma Modulator FHG65, Synchronizer FHG66	BA00373F/00 Operating Instructions for Gamma Modulator FHG65 and Synchronizer FHG66
FQG61/FQG62 source containers	TI00435F/00 Technical Information for source containers FQG61 and FQG62 (in phase out)
Gamma emitter FSG60/FSG61	TI00439F/00 Technical Information for gamma emitters FSG60/FSG61
Gammapilot M FMG60	<p>TI00363F/00 Technical Information for FMG60 Gammapilot M</p> <p>BA00236F/00 Operating Instructions for FMG60 Gammapilot M, HART</p> <p>BA00329F/00 Operating Instructions for FMG60 Gammapilot M, PROFIBUS PA</p> <p>BA00330F/00 Operating Instructions for FMG60 Gammapilot M, Foundation Fieldbus</p> <p>BA00287F/00 Description of Device Functions for FMG60 Gammapilot M</p>



71314969

www.addresses.endress.com
