

Technical Information

CUD33 compact turbidity device

Optical device for phase separation



Application

The CUD33 compact turbidity device is suitable for detecting and distinguishing between different products in:

- Phase separation between dairy products and water
- Phase separation between yeast and water in breweries, e.g. for yeast recovery

Benefits

- Maximized product yield: Detect the phases of your CIP process quickly and avoid product losses through accurate and rapid identification of phase changes.
- Compact design: Benefit from compact dimensions, space-saving installation and use of the device for phase separation even in confined spaces.
- Easy handling and truly maintenance-free by design: Only annual cleaning of the ball lens is required, regardless of CIP cycles. The innovative design without replaceable sealing materials eliminates the need for O-ring replacement and ongoing maintenance.
- Reliable measurement: The unique ball lens prevents interference caused by air bubbles.
- Simple to install: Various process connections enable easy installation in pipes. No further configuration is required, as the compact device provides measured values immediately after connection to the PLC.
- Material compliance: The phase separation device complies with Regulation (EC) 1935/2004 and FDA 21 CFR.
- Hygiene-compliant design: Some versions have 3-A and EHEDG certification.

Table of contents

Function and system design	3
Product design	3
Input	3
Measured variable	3
Measuring range	3
Power supply	3
Electrical connection	3
Performance characteristics	4
Resolution	4
Accuracy	4
Reproducibility	4
Wavelength	4
Light source	4
Installation	4
Installation instructions	4
Electrical data	5
Supply voltage	5
Output	5
Output signal	5
Environment	5
Ambient temperature range	5
Storage temperature	5
Process	5
Process temperature range	5
Max. permitted process pressure	5
Max. permitted sterilization temperature	5
Mechanical construction	5
Dimensions	5
Weight	5
Materials	6
Certificates and approvals	6
Additional certifications and declarations	6
Ordering information	6
Product page	6
Product Configurator	6
Scope of delivery	6

Function and system design

Product design

The device monitors the turbidity of liquids, reliably detects changes and enables continuous process control. It is particularly suitable for phase separation but also for turbidity-dependent concentration measurements, e.g. filter monitoring. The device is mounted on vessels or pipes via the process connection (item 2). The optical sensor head (item 1) extends into the process fluid and measures physical properties by backscattering the irradiated light.

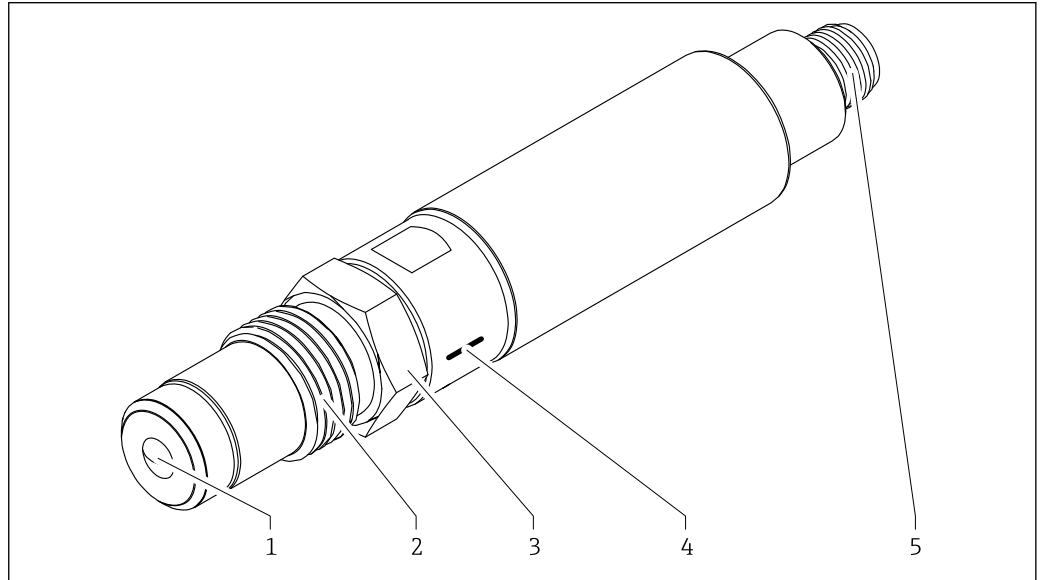

A0061286

- ☐ 1 *Optical device for phase separation*
- 1 *Optical sensor head (sapphire lens)*
 - 2 *Process connection*
 - 3 *Compression fitting*
 - 4 *Laser marking for reference standards*
 - 5 *M12 plug connection*

Input

Measured variable	Turbidity
Measuring range	0 to 100 %

Power supply

Electrical connection

Requirements for the electrical connection:

- The connecting cable must run entirely within a building and must not exit it.
- The maximum cable length is 30 m (98.4 ft).
- Use an unshielded standard cable M12 (5-pin) with a suitable connector.

M12 plug, 3-pin

Pin	Color	Description
1	Brown	DC + (24 V _{DC})
2	-	-
3	Blue	DC - (GND)
4	Black	Analog output 4 to 20 mA
5	-	-

A0061334

Performance characteristics

Resolution	0.1 %
Accuracy	± 1.5 %
Reproducibility	≤ 1 % of full scale value
Wavelength	850 nm
Light source	LED

Installation

The process connection integrates the device directly into pipelines or vessels. Adapters connect the device to existing process connections. The minimum permitted pipe diameter depends on the process connection or adapter selected. The insertion depth of the weld-in nozzle or the nozzle height of a Tri-Clamp connection determines the required pipe size.

Installation instructions

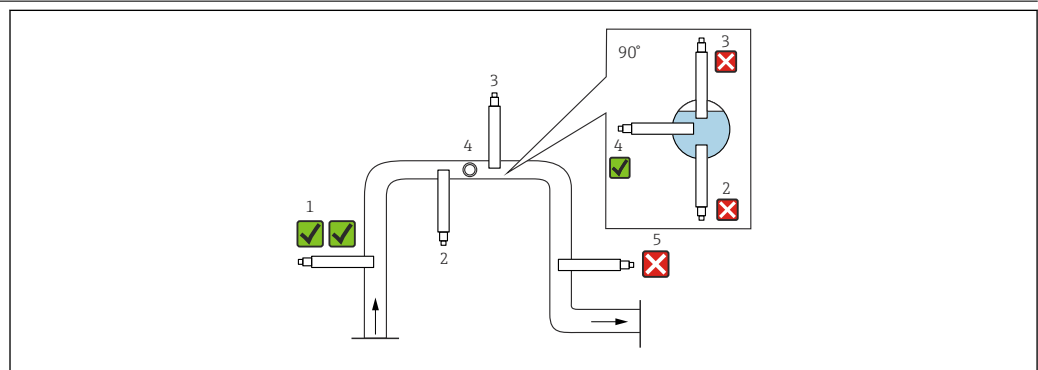

2 Permitted orientations in pipelines

- Install the device at locations with uniform flow conditions.
- The best installation location is in a riser pipe (item 1).
- Installation in a horizontal pipe (item 4) is also possible.
- Avoid installation in down pipes (item 5).
- Do not install the device in the following locations:
 - In the case of strong turbulence in the medium (air bubbles may form)
 - Directly after a pipe bend or inlet into the pipeline
- Minimum pipeline diameter DN10.

Electrical data

Supply voltage 24 V DC

Output

Output signal 4 to 20 mA

Environment

Ambient temperature range -10 to 70 °C (14 to 158 °F)

Storage temperature -20 to 80 °C (-4 to 176 °F)

Process

Process temperature range -10 to 100 °C (14 to 212 °F)

Max. permitted process pressure 20 bar (290 psi) nominal

Max. permitted sterilization temperature 135 °C (275 °F) (max. 2 hours)

Mechanical construction

Dimensions

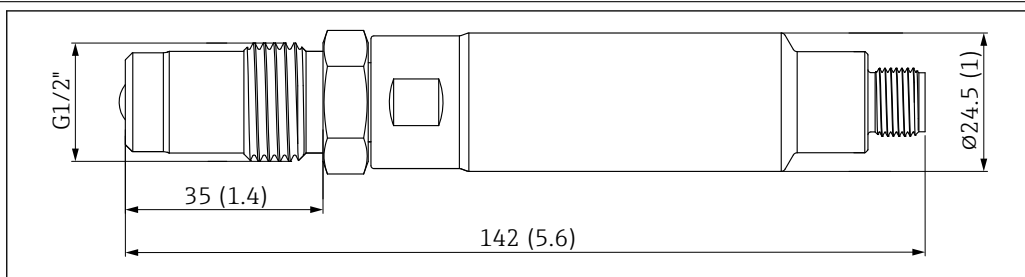

3 Dimensions with process connection G1/2". Unit: mm (in)

Weight

Device	Weight
Device without process adapter (with G1/2" connection)	195 g (6.9 oz)
Device with process adapter Tri-Clamp 1½"	260 g (9.2 oz)
Device with process adapter Tri-Clamp 2"	315 g (11.1 oz)
Device with process adapter Varivent N DN 40-125	770 g (27.2 oz)

Materials

Component	Material
Device	Stainless steel 1.4435 (316L) Surface roughness <0.37 µm (14.6 µin)
Optical window	Sapphire
Seal	AgCuTi (Lot)

Certificates and approvals

Current certificates and approvals for the product are available at www.endress.com on the relevant product page:

1. Select the product using the filters and search field.
2. Open the product page.
3. Select **Downloads**.

Additional certifications and declarations

The following test certificates, attestations and declarations (e.g. certificates of conformity) are available for the product depending on the selected version:

- EHEDG EL Class I
- 3-A
- US Food Contact Materials FDA CFR 21
- EU Food Contact Materials (EC) 1935/2004

Ordering information

Product page

www.endress.com/cud33

Product Configurator

1. **Configure:** Click this button on the product page.
 2. Select **Extended selection**.
 - ↳ The Configurator opens in a separate window.
 3. Configure the device according to your requirements by selecting the desired option for each feature.
 - ↳ In this way, you receive a valid and complete order code for the device.
 4. **Accept:** Add the configured product to the shopping cart.
-  For many products, you also have the option of downloading CAD or 2D drawings of the selected product version.
5. **CAD:** Open this tab.
 - ↳ The drawing window is displayed. You have a choice between different views. You can download these in selectable formats.

Scope of delivery

- The scope of delivery comprises:
- Device, version as ordered
 - Protective sleeve the optical measuring system
 - Operating instructions



71763862

www.addresses.endress.com
