

# Safety Instructions

## **OUSAF12, OUSAF21, OUSAF22, OUSAF44, OUSAF46, OUSTF10**

Process photometer

ATEX II 2G Ex db IIC T5 Gb  
FM Cl.1, Div. 1, Groups B, C, D



---

# OUSAF12, OUSAF21, OUSAF22, OUSAF44, OUSAF46, OUSTF10

Process photometer

## Table of contents

Related documentation .....	4
Supplementary documentation .....	4
Certificates and declarations .....	4
Identification .....	4
Safety instructions .....	5
Specific conditions of use .....	6
Temperature tables .....	6
Connection .....	6
Installation conditions .....	11

**Related documentation**

This document is an integral part of the following Operating Instructions:

- Operating Instructions OUSAF12, BA00497C
- Operating Instructions OUSAF21, BA00471C
- Operating Instructions OUSAF22, BA00472C
- Operating Instructions OUSAF44, BA00416C
- Operating Instructions OUSTF10, BA00500C

**Supplementary documentation**

Competence Brochure CP00021Z

- Explosion Protection: Guidelines and General Principles
- [www.endress.com](http://www.endress.com)

**Certificates and declarations**

The certificates and declarations of conformity are available in the Download area of the Endress+Hauser website:

[www.endress.com/download](http://www.endress.com/download)

**EU declaration of conformity**

EC\_00310

**EU-type examination certificate**

Sira 03 ATEX 1279 X

**Identification****Nameplate**

The following information on the device can be found on the nameplate:

- Manufacturer identification
- Order code
- Extended order code
- Serial number
- Safety information and warnings
- Ex markings
- Certificate number

► Compare the information on the nameplate with the order.

**Type code**

Type	Version				
OUSAF12- OUSAF21- OUSAF22- OUSTF10-	*	*	A/B/C/D C/D C/D B	1 1 1 1	* * * *
	Wavelength, calibration, no Ex-relevance		For use in hazardous areas, FM Cl.1, Div. 1, Groups B, C, D		Assembly, no Ex- relevance
OUSAF12- OUSAF21- OUSAF22- OUSTF10-	*	*	A/B/C/D C/D C/D B	2 2 2 2	* * * *
	Wavelength, calibration, no Ex-relevance		For use in hazardous areas, ATEX II 2G Ex db IIC T5 Gb		Assembly, no Ex- relevance

Type	Version				
OUSAF44-	*	*	B		*
	Wavelength, calibration, no Ex-relevance		For use in hazardous areas, FM Cl.1, Div. 1, Groups B, C, D		Assembly, no Ex- relevance
OUSAF44-	*	*	C		*

Type	Version		
	Wavelength, calibration, no Ex-relevance	For use in hazardous areas, ATEX II 2G Ex db IIC T5 Gb	Assembly, no Ex-relevance
OUSAF46-	*   *	B	*
	Wavelength, calibration, no Ex-relevance	For use in hazardous areas, FM Cl.1, Div. 1, Groups B, C, D	Assembly, no Ex-relevance
OUSAF46-	*   *	C	*
	Wavelength, calibration, no Ex-relevance	For use in hazardous areas, ATEX II 2G Ex db IIC T5 Gb	Assembly, no Ex-relevance

**Ex approvals**

- ATEX II 2G Ex db IIC T5 Gb
- CSA C/US XP Cl. I Div. 1&2 GP B-D T5 + CSA C/US IS Cl. I Div. 1&2 GP B-D T5 (detector)

**Notified bodies**

**CSA Group Netherlands B.V.**

Utrechtseweg 310, Building B42, 6812AR Arnhem, The Netherlands

**FM Approvals**

1151 Boston Providence Turnpike, P.O. Box 9102 Norwood, MA 02062 USA

**Safety instructions**

The process photometer measuring station, consisting of the certified process photometers OUSAF12, OUSAF21, OUSAF22, OUSAF44, OUSAF46 or OUSTF10 and cable set CUK80 may only be connected to a transmitter via the certified safety barrier MTL7760AC. The connecting requirements for the transmitter are 2 to 18 V, 6 VA (e.g. CM44P).

- The electrical connection must be established as illustrated in the relevant control drawings in this document and the installation instructions in the Operating Instructions for the process photometer.
- The process photometers may be used in environments that contain flammable gases and vapors and are assigned to equipment groups IIA, IIB, IIC (ATEX) and B, C, D (CAN/US), temperature class T5.
- Installation must be performed by trained personnel in compliance with applicable standards and guidelines, e.g. IEC/EN 60079-14 and EN/IEC 60079-17 or ANSI/NFPA-70 and as specified in the Operating Instructions for the particular process photometer and the transmitter to be connected.
- Sensor repairs must be performed by trained personnel in compliance with applicable standards and guidelines, e.g. IEC/EN 60079-19 and as specified in the sensor's Operating Instructions and the Operating Instructions for the transmitter to be connected.
- Component parts which are installed as accessories or replacement parts in these process photometers must be mounted by trained personnel in compliance with the manufacturer's documentation.
- If the process photometer can come into contact with aggressive substances, the user must take suitable protective measures to ensure that the confirmed level of protection of the measuring system is not compromised. Examples of aggressive substances include acidic liquids or gases that corrode metal, or solvents that can damage polymeric materials. Suitable protective measures involve regular checks as part of routine inspections, or checks to verify the resistance of the materials to special chemicals using the material data sheet.
- The optical receiver with photodiodes is operated in the current mode. The photodiodes generate energy below the voltage, current and power limits that are specified in IEC/EN 60079-11, Section 5.7. Therefore the equipment is categorized as a simple apparatus.
- The process photometers are classified as temperature class T5, permitting a maximum surface temperature of 100 °C (212 °F).
- Separation between the safe area and the hazardous area is achieved through the use of one or two approved MTL7760AC safety barriers. The safety barriers must be connected as illustrated in the relevant control drawings in this document, the installation instructions in the Operating Instructions for the process photometers, and the Operating Instructions for the safety barriers.
- If the transmitter and safety barrier are located in a hazardous area, observe the following requirements:
  - Cable set CUK80 must be installed in a conduit or other suitable wiring method approved for use with hazardous area equipment, in accordance with the ATEX Directive, NEC or CEC.
  - Only certified devices that are approved for the relevant hazardous areas may be used.

- The wiring between the sensor and transmitter must comply with the applicable safety standards. Seals and conduits must be provided by the customer.
- Do not remove covers during operation.
- Cable set CUK80 must be protected against electrostatic charge when routed through ATEX Zone 0.
- The OUA260/CUA261 flow assemblies may only be used in the hazardous area with stainless steel adapters.
- Do not remove the sensor (lamp and/or detector) from the flow assembly if the process temperature exceeds 95 °C (203 °F).

### Specific conditions of use

- The hazardous area lamp EXP-1 must cool down before the housing is opened. After switching off the power supply, first wait for 5 minutes before you open the photometer housing.
- The hazardous area lamp EXP-1 must be installed in such a way that the front window is protected against mechanical damage.
- The hazardous area lamp EXP-1 has a permanently connected cable end which must be connected to an external circuit according to the instructions in these Operating Instructions and the installation instructions in the Operating Instructions for the process photometer.
- In accordance with Section 7.5 IEC/EN 60079-0, the devices must be grounded and the resistance must not exceed  $10^9 \Omega$ .

### Temperature tables

Photometer	Process temperature	Ambient temperature	Temperature class
OUSAF12	0 to 90 °C (32 °F to 194 °F) (continuous operation) max. 130 °C (266 °F), for max. 2 h	-20 to 40 °C (0 to 100 °F)	T5 ≤ 100 °C (≤ 212 °F)
OUSAF21			
OUSAF22			
OUSAF44			
OUSAF46			
OUSTF10			

If the specified process temperatures are complied with, temperatures that are not permitted for the respective temperature class will not occur on the equipment.

### Connection



For further information on terminal assignment, see the corresponding Operating Instructions for the photometer sensor.

#### Connecting the detector using a safety barrier

The photometer sensors use silicon photovoltaic cells as detectors which are operated in the current mode. The detectors are intrinsically safe and can be deployed in Zone 1 and Class I, Division 1 environments.

Separation between the safe area and the hazardous area is achieved by means of one or two MTL7760AC safety barriers.

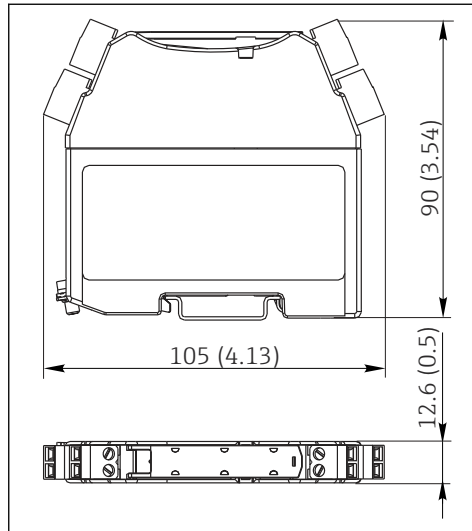

1 Safety barrier, dimensions in mm (inch)

**i** The safety barrier may only have a very low leak current since the optical signals from the sensor can be in the nanoampere range. Therefore, the sensor cable shield is connected to the ground terminal of the barrier.

The detector cable of the CUK80 is supplied factory-wired to the safety barrier(s).

1. Mount the safety barrier(s), including the grounding module, on a DIN rail.

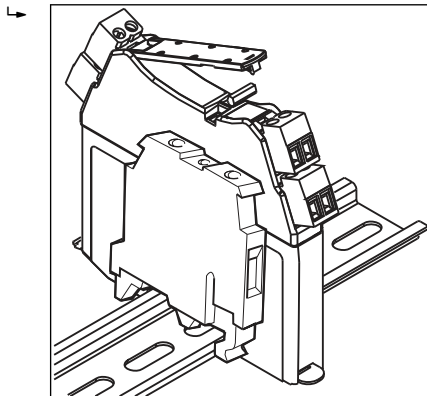

2 OUSAF12, OUSAF44

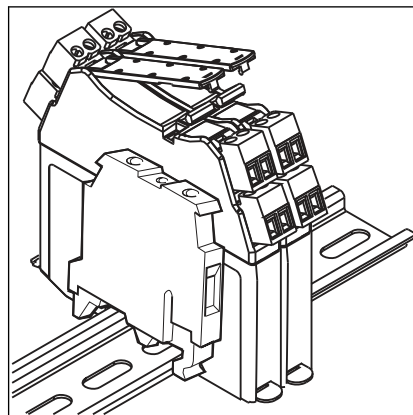

3 OUSAF21, OUSAF22, OUSAF46, OUSTF10

2. Connect the detector plug of the cable to the detector.
3. Connect the other end of the cable to the transmitter.

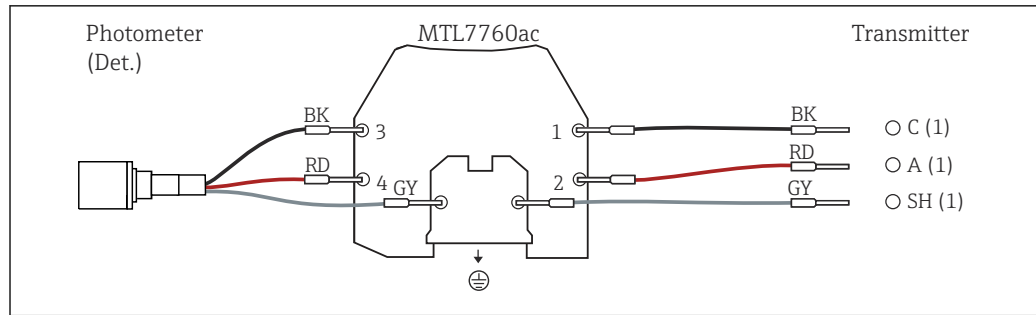

4 OUSAF12, OUSAF44

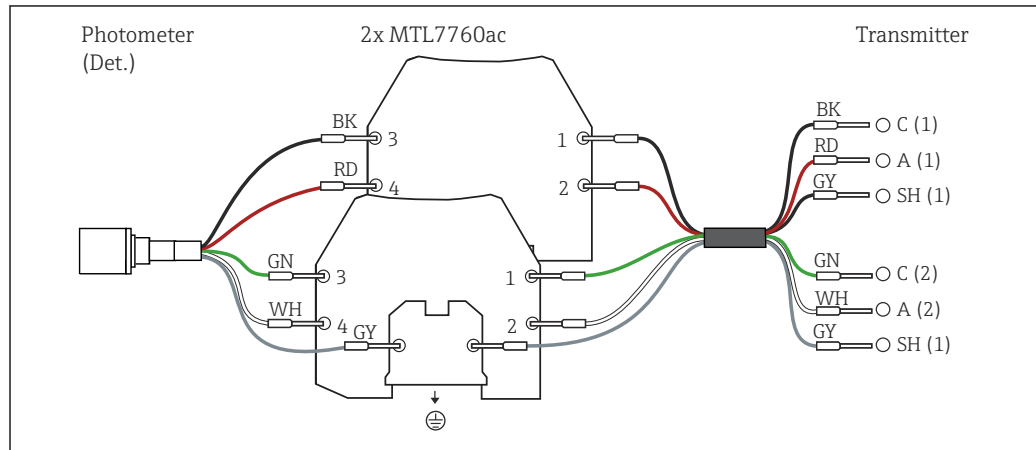

5 OUSAF21, OUSAF22, OUSAF46, OUSTF10

#### Connecting the hazardous area lamp to the transmitter via a junction box

The hazardous area lamp (EXP-1) must be connected to the transmitter using a certified junction box.

**i** For versions with FM approval, the junction box is included in the delivery and already pre-terminated on the lamp side. You simply have to connect the cable of the transmitter (CUK80) to the terminals of the junction box.

For versions with ATEX approval, the junction box is not included in the delivery and it and the cable glands required must be provided by the customer at the place of installation. You must connect the cables entirely on your own (CUK80 of transmitter and lamp cable of photometer sensor).

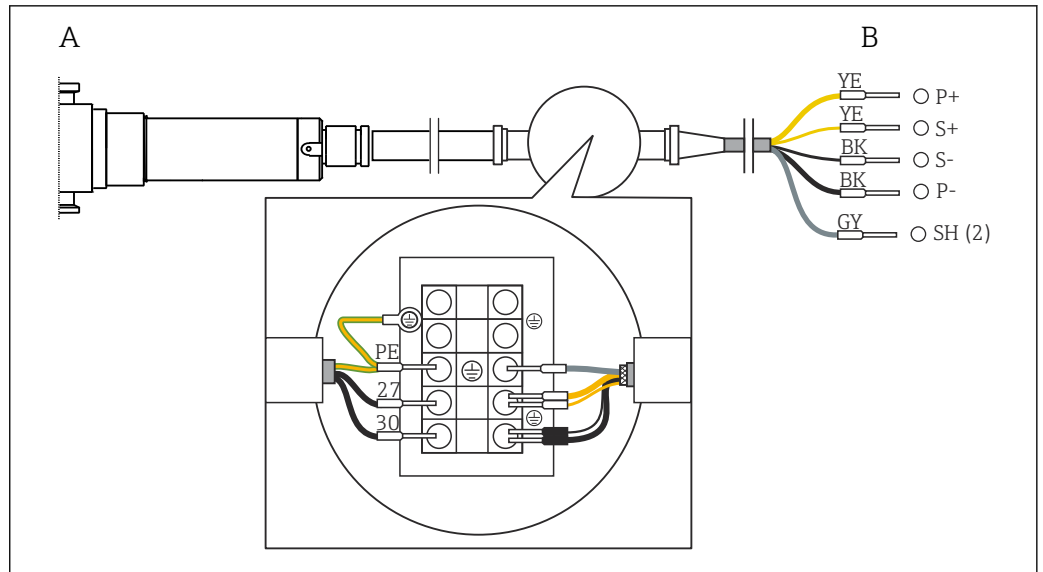

A0062145

6 OUSAF12, OUSAF21, OUSAF22, OUSTF10: Connecting the hazardous area lamp to the transmitter via the junction box

- A Hazardous area lamp (EXP-1)
- B Transmitter

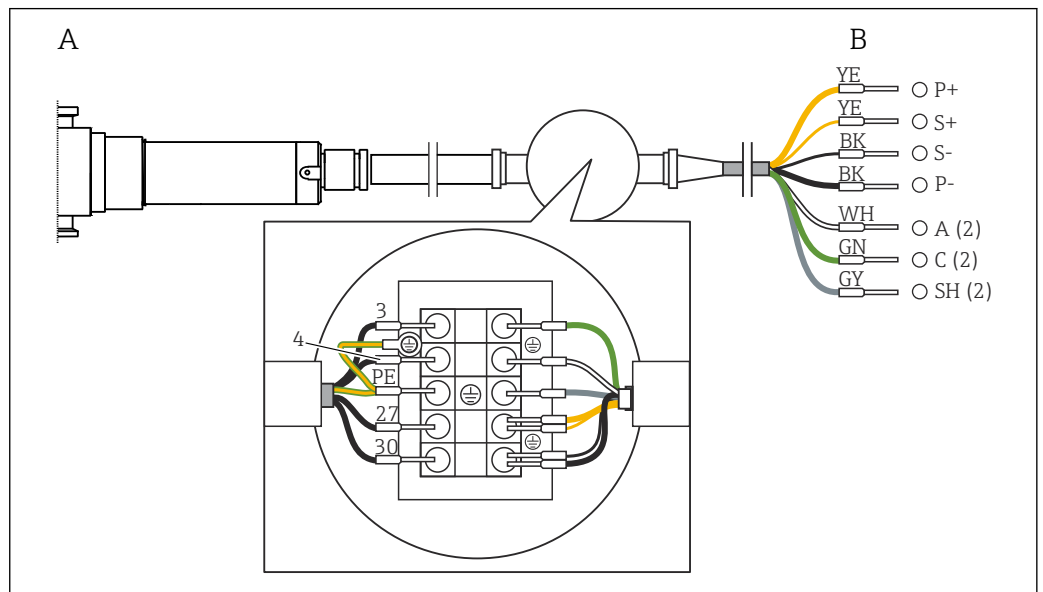

A0062146

7 OUSAF44: Connecting the hazardous area lamp to the transmitter via the junction box

- A Hazardous area lamp (EXP-1)
- B Transmitter

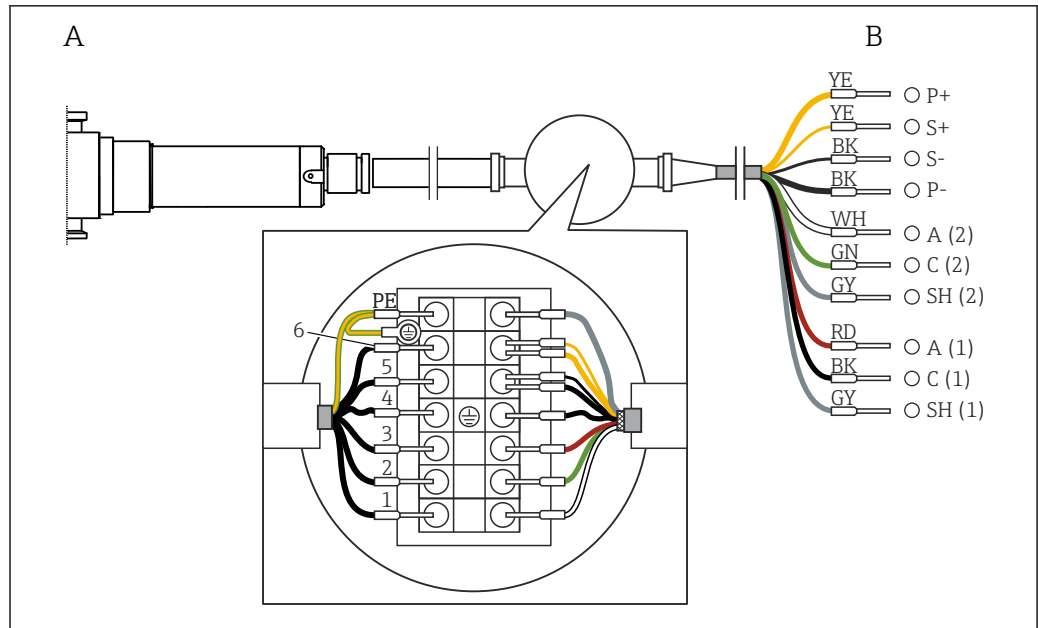

A0062162

8 OUSAF46: Connecting the hazardous area lamp to the transmitter via the junction box

- A Hazardous area lamp (EXP-1)
- B Transmitter

Installation conditions

FM

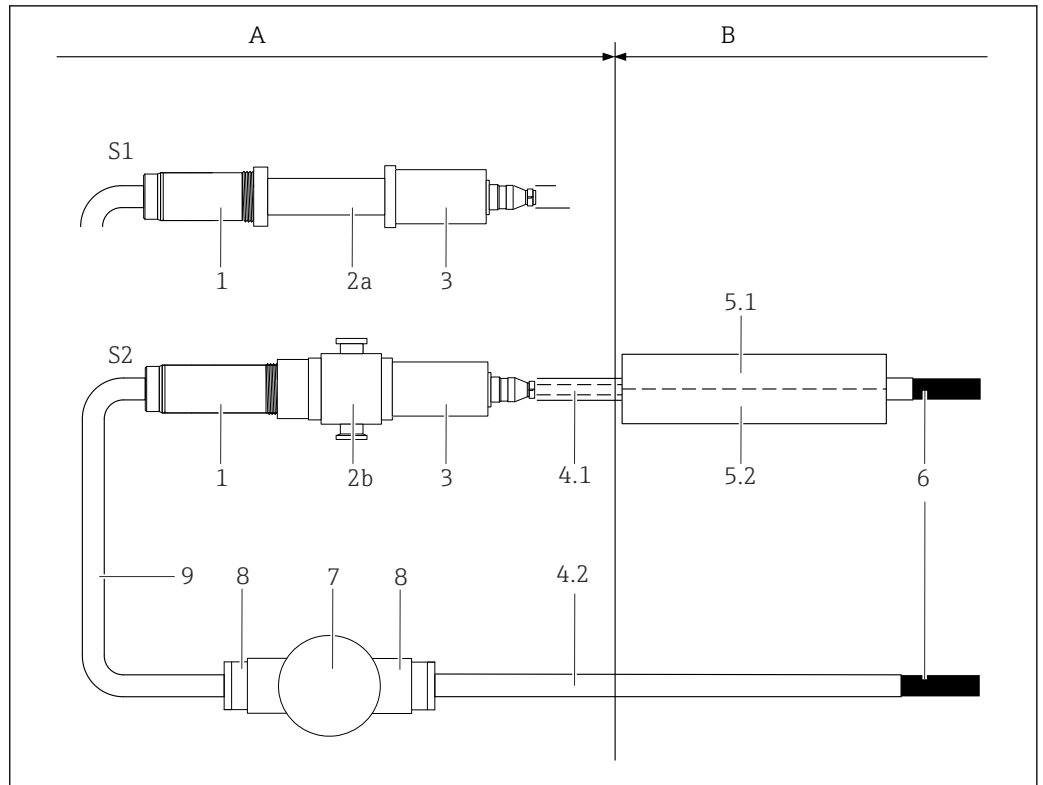

A0059499

9 Control drawing FM

A Hazardous area, class I, division 1, gas groups B, C, D, temperature class T5

B Non-hazardous area or hazardous area

1 EXP-1 lamp (FM approved)

2a Assembly for OUSAF21

2b Assembly OUA260 or CUA261 for OUSAF12, OUSAF22, OUSAF44, OUSAF46 or OUSTF10

3 Intrinsically safe optical detector

4.1 Cable set CUK80 or other suitable wiring method for intrinsically safe wiring

4.2 Cable set CUK80 must be routed in a conduit. Alternatively, another suitable wiring method suitable for the intended environment and permitted for use with flameproof equipment in accordance with NEC or CEC must be used.

5.1 MTL7760AC safety barrier (included in CUK80 delivery, connect to ground). Follow the manufacturer's instructions, particularly for installation in hazardous areas.

5.2 Second MTL7760AC safety barrier for OUSAF21, OUSAF22, OUSAF46 or OUSTF10 (see 5.1)

6 Connection to the transmitter e.g. CM44P. If the transmitter and safety barrier are located in a hazardous area, carry out installation using a suitable wiring method in accordance with the NEC or CEC that is approved for use with hazardous equipment.

7 Hazardous area junction box, FM approved, included in the scope of delivery (connect to ground)

8 Hazardous area cable gland, FM approved (to be provided in part by the customer)

9 Flexible conduit (integrated into the EXP-1 lamp)

## ATEX

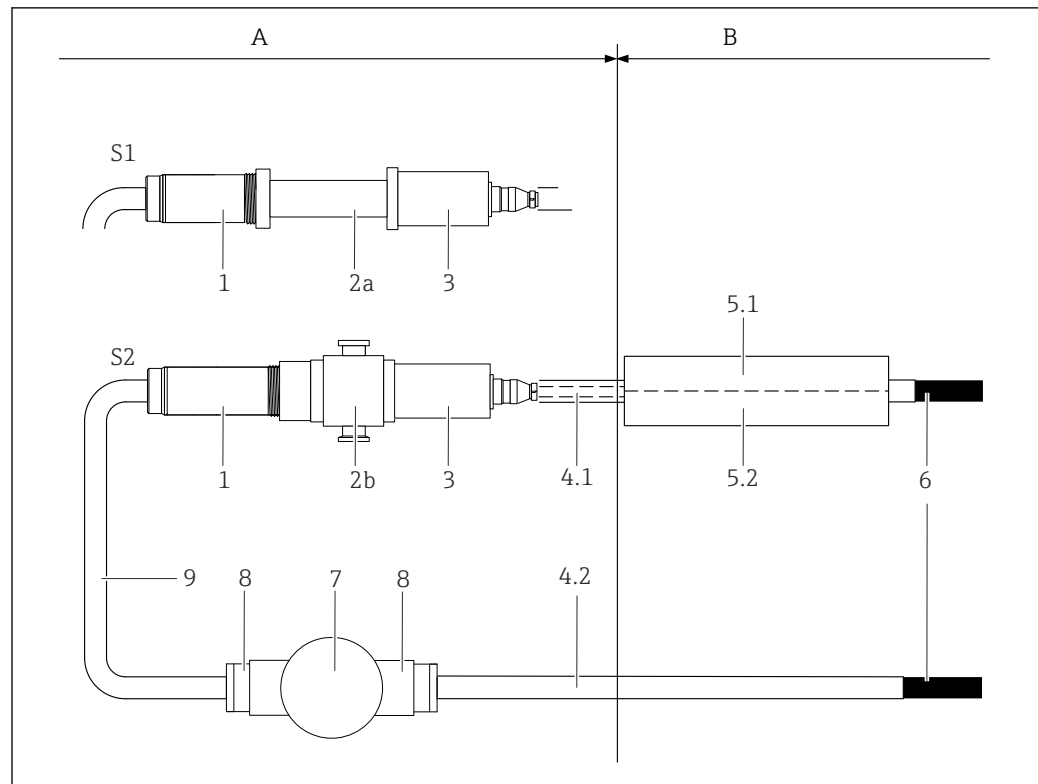

A0059499

■ 10 Control drawing ATEX

A Hazardous area, zone 1, gas groups IIC, IIB, IIA, temperature class T5

B Non-hazardous area or hazardous area

1 EXP-1 lamp (ATEX-compliant)

2a Assembly for OUSAF21

2b Assembly OUA260 or CUA261 for OUSAF 12, OUSAF22, OUSAF44, OUSAF46 or OUSTF10

3 Intrinsically safe optical detector

4.1 Cable set CUK80 or other suitable wiring method for intrinsically safe wiring

4.2 Cable set CUK80 must be routed in a conduit. Alternatively, another suitable wiring method suitable for the intended environment and permitted for use with flameproof equipment in accordance with the ATEX Directive must be used.

5.1 MTL7760AC safety barrier (included in CUK80 delivery, connect to ground). Follow the manufacturer's instructions, particularly for installation in hazardous areas.

5.2 Second MTL7760AC safety barrier for OUSAF21, OUSAF22, OUSAF46 or OUSTF10 (see 5.1)

6 Connection to the transmitter e.g. CM44P. If the transmitter and safety barrier are located in a hazardous area, carry out installation using a suitable wiring method in accordance with the ATEX Directive that is approved for use with hazardous area equipment.

7 Hazardous area junction box, ATEX-compliant, not included in the scope of delivery (connect to ground)

8 Hazardous area cable gland, ATEX-compliant (to be provided in part by the customer)

9 Flexible conduit (integrated into the EXP-1 lamp)

---

---

---



[www.addresses.endress.com](http://www.addresses.endress.com)

---