

Safety Instructions

iTHERM TrustSens TM371

Ex ia IIC T6...T1 Ga/Gb

Ex ia IIIC T₂₀₀85 °C...T₂₀₀450 °C Da/

Ex ia IIIC T85 °C...T450 °C Db



iTHERM TrustSens TM371

Table of contents

| | |
|---|---|
| About this document | 3 |
| Associated documentation | 3 |
| Supplementary documentation | 3 |
| Certificates and declarations | 3 |
| Manufacturer address | 3 |
| Safety instructions | 4 |
| Safety instructions: Installation | 4 |
| Safety instructions: Installation in equipment of Group III | 5 |
| Safety instructions for intrinsic safety: Installation | 5 |
| Safety instructions: Partition wall | 5 |
| Safety instructions: Specific conditions of use | 5 |
| Temperature tables | 6 |
| Connection data | 7 |

About this document

The document number of these Safety Instructions (XA) must match the information on the nameplate.

Associated documentation

To commission the device, please observe the Operating Instructions pertaining to the device:

www.endress.com/<product code>, e.g. iTHERM TM371

Supplementary documentation

Explosion protection brochure: CP00021Z

The explosion protection brochure is available on the Internet:

www.endress.com/Downloads

Certificates and declarations**NEPSI certificate**

Certificate number: GYJ26.1082X

Affixing the certificate number certifies conformity with the following standards (depending on the device version)

- GB/T 3836.1-2021
- GB/T 3836.4-2021



Please refer to NEPSI/CCC certificates for conditions of safe use.

Manufacturer address

Endress+Hauser Wetzer GmbH + Co. KG

Obere Wank 1

87484 Nesselwang, Germany

Endress+Hauser Wetzer (Suzhou) Co. Ltd.

No.31 JiangTianLilu

Suzhou Industrial Park (SIP) Suzhou 215126, China

Safety instructions

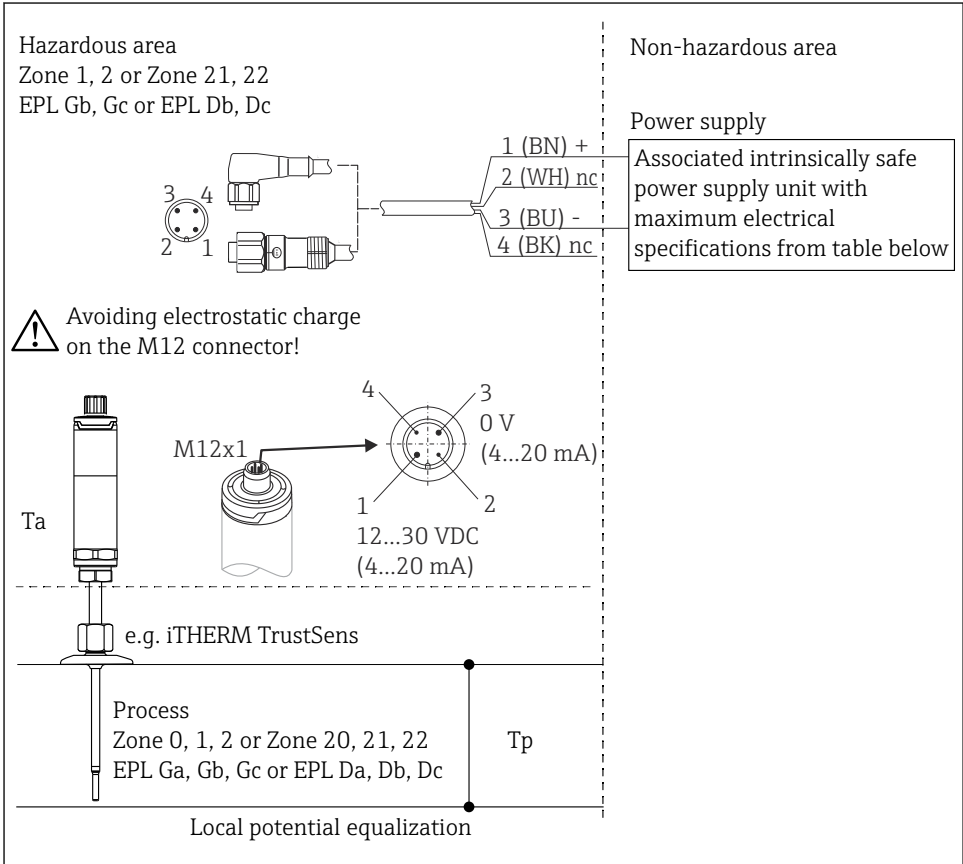

A0049293

**Safety instructions:
Installation**

- Comply with the installation and safety instructions in the Operating Instructions.
- Install the device according to the manufacturer's instructions and any other valid standards and regulations (e.g. EN/IEC 60079-14).
- The housing of the thermometer must be connected to the local potential equalization or installed in a grounded metallic piping or tank respectively.
- It cannot be taken for granted that when using compression fittings with non-metallic olives that there is a secure grounding when installing in a metal system. This means that an additional safe connection to the local potential equalization needs to be used.

Safety instructions: Installation in equipment of Group III

The device must be installed and maintained so, that even in the event of rare incidents, an ignition source due to impact or friction between the enclosure and iron/steel is excluded.

Safety instructions for intrinsic safety: Installation

- The type of protection changes as follows when the devices are connected to certified intrinsically safe circuits of category ib: Ex ib IIC. When connecting to an intrinsically safe ib circuit, do not operate the sensor at Zone 0 without any thermowell according to EN/IEC 60079-26.
- The thermometer is not isolated to the metallic enclosure in conformance with EN/IEC 60079-11 chapter 6.3.13.
- Associated equipment with galvanic isolation between the intrinsically safe and non-intrinsically safe circuits is required for supplying.
- For interconnecting the thermometer with the optionally provided cable sets following parameters can be assumed: $C_c = 200 \mu\text{F}/\text{m}$ and $L_c = 1 \mu\text{H}/\text{m}$.

Safety instructions: Partition wall

- Install the thermometer in a partition wall which is in compliance with EN/IEC 60079-26 in reference to its ultimate application.
- The provided thermowells per option code are out of AISI 316L/1.4404 or 1.4435 with a wall thickness $\geq 1 \text{ mm}$

Safety instructions: Specific conditions of use

- The suffix "X" placed after the certificate number indicates that this product is subject to special conditions for safe use, that is:
- From the safety point of view, the thermometer shall be considered to be connected to earth. For details, the instruction manual, provided with the equipment, shall be observed.
- Only isolated barriers may be selected for the associated apparatus.
- It is not permitted to use the configuration pins 2 and 4 when the thermometer is connected to electrical supply.

- Electrostatic charge on the M12 connector shall be avoided in dust explosive atmospheres during operation and maintenance.
- For installation, use and maintenance of this product, the end user shall observe the instruction manual and the following standards:
 - GB/T 3836.13-2021 “Explosive atmospheres- Part 13: Equipment repair, overhaul, reclamation and modification”.
 - GB 3836.15-2024 “Explosive atmospheres- Part 15: Electrical installations design, selection and erection”.
 - GB 3836.16-2024 “Explosive atmospheres- Part 16: Electrical installations inspection and maintenance”.
 - GB 3836.18-2024 “Explosive atmospheres- Part 18: Intrinsically safe electrical systems”.
 - GB50257-2014 “Code for construction and acceptance of electric equipment on fire and device for explosion hazard electrical installation engineering”.
 - GB15577-2018 “Safety regulations for dust explosion prevention and protection”
- The relationship between the product's ambient temperature range and maximum medium temperature and its explosion protection marking and temperature class:

Temperature tables

| Type | Temperature class | Ambient temperature range housing Ta | Maximum surface temperature housing |
|------------------------|-------------------|---|-------------------------------------|
| iTHERM TrustSens TM371 | T6 | $-40\text{ °C} \leq T_a \leq +55\text{ °C}$ | T85 °C |
| | T5 | $-40\text{ °C} \leq T_a \leq +70\text{ °C}$ | T100 °C |
| | T4 | $-40\text{ °C} \leq T_a \leq +85\text{ °C}$ | T135 °C |

| Type | Insert diameter | Process temperature range Tp | Temperature class/ Maximum surface temperature sensor |
|------------------------|-----------------|--|--|
| iTHERM TrustSens TM371 | 3 mm 6 mm | $-50\text{ °C} \leq T_p \leq +75\text{ °C}$ | T6/T85 °C |
| | | $-50\text{ °C} \leq T_p \leq +90\text{ °C}$ | T5/T100 °C |
| | | $-50\text{ °C} \leq T_p \leq +125\text{ °C}$ | T4/T135 °C |
| | | $-50\text{ °C} \leq T_p \leq +190\text{ °C}$ | T3/T200 °C |
| | | $-50\text{ °C} \leq T_p \leq +285\text{ °C}$ | T2/T300 °C |
| | | $-50\text{ °C} \leq T_p \leq +435\text{ °C}$ | T1/T450 °C |

Connection data

| Type | | Electrical data |
|------------------------|--|--|
| iTHERM TrustSens TM371 | Power supply Connecting socket Pin 1(+) and 3(-) | $U_i \leq 30 V_{DC}$ $I_i \leq 100 \text{ mA}$ $P_i = 750 \text{ mW}$ $P_i = 600 \text{ mW}$ (for dust applications only) $C_i = \text{negligibly small}$ $L_i = \text{negligibly small}$ |
| | Configuration Connecting socket Pin 2 and 4 | $U_i \leq 30 V_{DC}$ $I_i \leq 100 \text{ mA}$ $P_i = 600 \text{ mW}$ (for dust applications only) $C_i = \text{negligibly small}$ $L_i = \text{negligibly small}$ |



71771293

www.addresses.endress.com
