

Technical Information

Fermentation Monitor

QWX43

Continuous monitoring of key parameters such as alcohol content, extract content and original gravity in beer



Application

High-precision multi-sensor technology for measuring density, sound velocity, viscosity, and temperature of liquids. Compact device for continuous monitoring of fermentation processes in breweries.

- Installation in tanks with IP66/67 housing protection
- Hygienic sensor made of 316L, constructed in accordance with 3-A and EHEDG specifications and certified in accordance with 3-A
- Sensor lengths up to 2 m (6.6 ft)
- Ideal alternative to costly laboratory measurements in the brewery sector
- Two variants: "Direct integration" variant for process control in an existing control system or "Netilion Server platform" variant with a web interface for monitoring

Your benefits

- Minute-by-minute updating of key parameters in fermentation process – enables continuous monitoring
- No on-site presence required - accurate and repeatable measurements replace laboratory analysis
- Information can be accessed anytime and anywhere – via smartphone, tablet, PC or control system
- Automatic notifications, for example when desired fermentation levels are reached – for more efficient cooling and green beer transfer, among other things
- Comparison of values from previous batches – enables data-based process improvements
- Automatic creation, storage and download of batches and values – reduces the effort involved in documentation and filing and replaces manual batch tracking

Table of contents

Document information	3	Mechanical construction	19
Symbols	3	Design, dimensions	19
Function and system design	5	Dimensions	20
Measuring principle	5	Weight	23
System configuration: Direct integration version	5	Materials	24
System design of Netilion server platform version	5	Surface roughness	24
Input	7	Operability	25
Measured variable	7	Direct integration	25
Measuring range	9	Netilion server platform	25
Output	10	Certificates and approvals	26
Output signal	10	CE mark	26
Signal on alarm	10	Sanitary compatibility	26
Protocol-specific data	10	3-A	26
Information on wireless connection	10	Radio approvals	26
Power supply	12	Accessories	26
Supply voltage	12	Weather protection cover for single-compartment housing	26
Power consumption	12	Plug-in jack with connecting cable	26
Current consumption	12	Wireless access point for direct integration version	27
Electrical connection	12	Ordering information	27
Overvoltage protection	12	Scope of delivery	27
Performance characteristics	13	Supplementary documentation	28
Response time	13	Standard documentation QWX43	28
Reference conditions	13	Registered trademarks	29
Measured value resolution	13		
Measurement error	13		
Repeatability	13		
Measurement uncertainty	13		
Design fundamentals	13		
Vibration effects	13		
Mounting	14		
Mounting location	14		
Installation instructions	14		
Environment	17		
Ambient temperature range	17		
Storage temperature	17		
Operating height	17		
Humidity	17		
Climate class	17		
Degree of protection	17		
Shock and vibration resistant	17		
Mechanical stress	17		
Internal cleaning	17		
Electromagnetic compatibility (EMC)	17		
Process	18		
Process temperature range	18		
Process pressure range	18		

Document information

Symbols

Safety symbols



This symbol alerts you to a dangerous situation. Failure to avoid this situation will result in serious or fatal injury.



This symbol alerts you to a dangerous situation. Failure to avoid this situation can result in serious or fatal injury.



This symbol alerts you to a dangerous situation. Failure to avoid this situation can result in minor or medium injury.



This symbol contains information on procedures and other facts which do not result in personal injury.

Electrical symbols



Direct current



Alternating current



Direct and alternating current



Ground connection

Grounded clamp, which is grounded via a grounding system.



Protective earth (PE)

Ground terminals, which must be grounded prior to establishing any other connections. The ground terminals are located on the inside and outside of the device.

Symbols for certain types of Information



Permitted

Procedures, processes or actions that are permitted



Preferred

Procedures, processes or actions that are preferred



Forbidden

Procedures, processes or actions that are forbidden



Tip

Indicates additional information



Reference to documentation



Reference to page



Reference to graphic



Visual inspection

Reference to graphic

Visual inspection

Symbols in graphics

1, 2, 3, ...

Item numbers

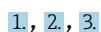

1, 2, 3

Series of steps

A, B, C, ...

Views

A-A, B-B, C-C etc.

Sections

 **Hazardous area**

Indicates the hazardous area

 **Safe area (non-hazardous area)**

Indicates the non-hazardous area

Function and system design

Measuring principle

The Fermentation Monitor QWX43 is a measuring instrument for monitoring temperature, density, viscosity and sound velocity. The device is specifically used for monitoring the concentration of beer-specific values such as extract and alcohol.

The measuring principle is based on a combination of the vibronic principle with an integrated temperature measurement and a sound velocity measurement using ultrasound. The compact device is installed directly in the tank and is powered by a separate supply voltage. The IP66/67-rated housing contains a web server via which the sensor measured values are either sent to a PLC or to the Netilion server platform, irrespective of the version.

Two versions of the Fermentation Monitor QWX43 are available: the "Netilion server platform" version and the version for "Direct integration".

Direct integration version

The web server integrated in the housing sends the sensor measured values to a wireless access point outside the Internet, from where they are forwarded to the customer's automation system via a wired connection and the TCP/IP protocol.

Netilion server platform version

The web server integrated in the housing is connected to the Internet and sends the measured values directly to the Endress+Hauser Netilion server platform via the user's Internet interface. The values can be called up and saved via the Endress+Hauser hosted Netilion server platform by means of the Netilion Fermentation app.

System configuration: Direct integration version

The QWX43 can be Fermentation Monitor connected to the web server and commissioned via a function block in the control system.

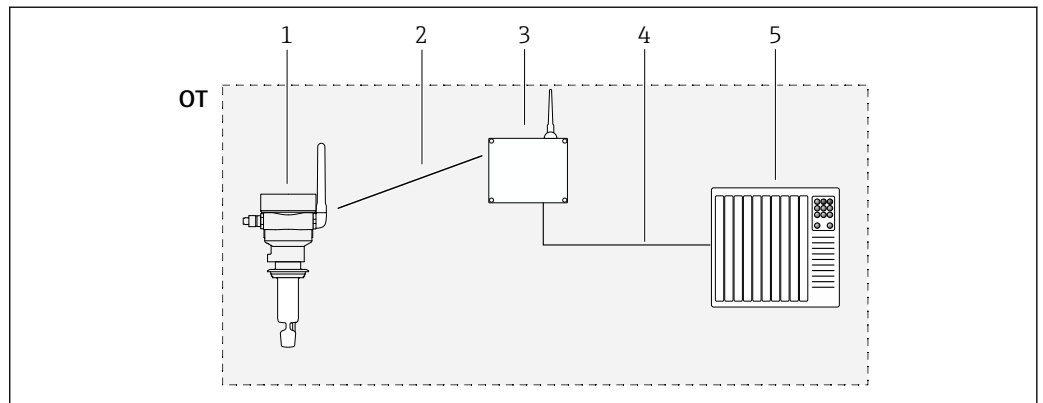

1 System configuration Fermentation Monitor QWX43 – Direct integration

- OT Operational Technology, in this context, fieldbus network outside the Internet
- 1 Fermentation Monitor QWX43
 - 2 WLAN connection (wireless connection)
 - 3 Wireless access point
 - 4 Wired connection: control system (TCP/IP)
 - 5 Automation system

System design of Netilion server platform version

The Fermentation Monitor QWX43 can be put into operation with the following digital application: Netilion Fermentation: <https://Netilion.endress.com/app/fermentation>

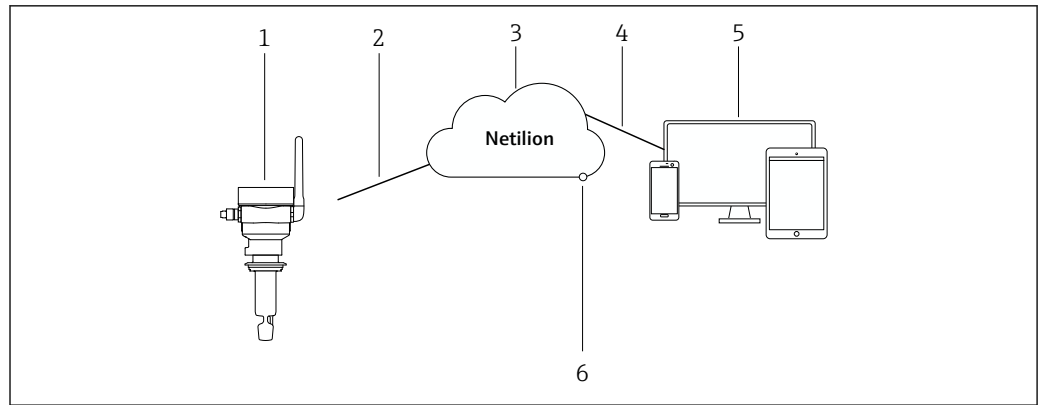

A0046711

2 System design of Fermentation Monitor QWX43

- 1 Fermentation Monitor QWX43
- 2 WLAN HTTPS Internet connection (mTLS 1.2)
- 3 Netilion server platform
- 4 https Internet connection
- 5 Netilion Services: browser-based Netilion service app
- 6 Netilion Connect: Application Programming Interface (API)

Detailed information on the Netilion server platform: <https://netilion.endress.com>

Input

Measured variable

Measured process variables

- Viscosity in mPa·s
- Density in g/cm³
- Temperature in °C
- Sound velocity in m/s

Calculated process variables

Process variable	Unit	Notes
Temperature	°F	Temperature of medium in °F
Density (20 °C)	g/cm ³	Density, standardized to 20 °C
Density (15.6 °C)	g/cm ³	Density, standardized to 15.6 °C
SG (20 °C) ¹⁾ (Specific density (20 °C))	–	Specific density calculated from the density of the medium and the density of water at 20 °C
Viscosity (20 °C)	mPa·s	Viscosity, temperature-compensated and standardized to 20 °C
Original gravity	°Plato ²⁾	Original gravity back-calculated from the alcohol and extract content
Real extract	%w/w ³⁾	Real extract, calculated from the combination of ultrasonic and density measurement
Apparent extract	%w/w ³⁾	Apparent extract based on density measurement and conversion according to Balling formula
Alcohol (% w/w)	%mass	Alcoholic content calculated from the combination of ultrasonic and density measurement, standardized to 20 °C
Alcohol (%vol)	%vol	Alcoholic content calculated from the combination of ultrasonic and density measurement, standardized to 20 °C
Alcohol (%vol) (15 °C) ¹⁾	%vol	Alcoholic content calculated from the combination of ultrasonic and density measurement, standardized to 15.6 °C
Real fermentation degree	%	Real fermentation degree based on the measured actual extract
Apparent fermentation degree	%	Apparent fermentation degree based on the measured apparent extract
Fermentable sugars	%w/w ³⁾	Percentage of fermentable sugars (Maltotriose, maltose, glucose, fructose, etc.) from the original wort shown from 1 %vol alcohol during the fermentation process
Non-fermentable sugars	%w/w ³⁾	Percentage of non-fermentable sugars (dextrin) from the original wort shown from 1 %vol alcohol during the fermentation process
Concentration CO ₂	%mass	In the case of the direct integration version, this process variable is made available to the PLC as a service parameter. The value is not representative of the actual CO ₂ concentration in the beer. Calculated from the equilibrium pressure depending on the tank top pressure and medium temperature

Process variable	Unit	Notes
Fermentation speed	%vol/h	Calculated from the rate of alcohol production per hour
Density (20 °C)_MEBAK	g/cm ³	Density, standardized to 20 °C, corrected based on the MEBAK correction ⁴⁾
Density (15.6 °C)_MEBAK	g/cm ³	Density, standardized to 15.6 °C, corrected based on the MEBAK correction ⁴⁾
SG (20 °C)_MEBAK (Specific density (20 °C)_MEBAK)	–	Specific density calculated from the density of the medium and that of the water at 20 °C, corrected based on the MEBAK correction
Original gravity_MEBAK	°Plato ²⁾	Original gravity back-calculated from the alcohol and extract content and corrected based on the MEBAK correction
Real extract_MEBAK	%w/w ³⁾	Real extract, calculated from the combination of ultrasonic and density measurement, corrected based on the MEBAK correction ⁴⁾
Apparent extract_MEBAK	%w/w ³⁾	Apparent extract based on density measurement and conversion according to Balling formula, corrected based on the MEBAK correction ⁴⁾
Alcohol (%w/w)_MEBAK	%mass	Alcohol content standardized to 20 °C, calculated from the combination of ultrasonic and density measurement, corrected based on the MEBAK correction ⁴⁾
Alcohol (%vol)_MEBAK	%vol	Alcohol content standardized to 20 °C, calculated from the combination of ultrasonic and density measurement, corrected based on the MEBAK correction ⁴⁾
Alcohol (%vol) (15 °C)_MEBAK ¹⁾	%vol	Alcohol content calculated from the combination of ultrasonic and density measurement, standardized to 15.6 °C, corrected based on the MEBAK correction ⁴⁾
Real fermentation degree_MEBAK	%	Real fermentation degree, based on the measured real extract, corrected based on the MEBAK correction ⁴⁾
Apparent fermentation degree_MEBAK	%	Apparent fermentation degree, based on the measured apparent extract, corrected based on the MEBAK correction
TS original gravity	%mass	Total solids measured gravimetrically that remain in the oven after drying the wort at 120 °C. Represents all the substances in the wort apart from alcohol and water.
TS real extract	%mass	Total solids of the real extract measured gravimetrically that remain in the oven after drying the wort at 120 °C. Represents all the substances in the wort apart from alcohol and water.

1) From software version 4.2

2) °Plato: Equivalent to the density of a correspondingly concentrated sucrose solution at 20 °C

3) The unit %w/w corresponds to the unit °Plato. The unit was adapted with software version 4.2.

4) MEBAK allows for a specific type of laboratory sample preparation, in particular filtering, which physically changes the sample. These changes are taken into account using the "MEBAK correction" of the measured values within the sensor to ensure comparability of laboratory measured values with the measurements in the tank.

Measuring range

Measured process variables

- Viscosity: 0 to 20 mPa·s
- Density: 0.95 to 1.15 g/cm³
- Temperature for fermentation: -5 to +35 °C (+23 to +95 °F)
- Sound velocity: 1 200 to 1 800 m/s

Calculated process variables

- Original gravity/extract: up to 32 °Plato
- Alcohol: Up to 12 %mass

If 32 °Plato and/or 12 %mass or 15 %vol alcohol are exceeded, no measured value is output.

Output

Output signal

Direct integration

A web server is integrated in the Fermentation Monitor. The Fermentation Monitor is configured using this web server and is thus connected to a wireless access point or integrated into the customer network of the automation system.

- Wireless connection (WLAN 2.4 GHz): TCP/IP
- Encryption: WPA2-PSK
- Wired connection to a TCP/IP control system (LAN 10/100 Mbit/s Ethernet)
 - The following control systems are supported:
 - Siemens S7
 - Rockwell CompactLogix
 - Rockwell ControlLogix
- Transmission rate: 1/min

Netilion server platform

A web server is integrated in the Fermentation Monitor. This web server is used to connect the Fermentation Monitor to the Endress+Hauser Netilion server platform via the customer WLAN.

- WLAN: 2.4 GHz
- Encryption: WPA2-PSK
- Ports: TCP Port 443, SNMP Port 123
- Protocol: mTLS (protocol versions: TLS 1.2/TLS 1.3)
- Transmission rate: 1/min

In the event of a network failure, the measured data are stored in the device for a maximum of one week.

Signal on alarm

Direct integration

- LED signaling directly on the device
- Diagnostic messages via error bits within the data module to the control system

Netilion server platform

- LED signaling directly on the device
- Diagnostic messages via Netilion Fermentation

Protocol-specific data

Direct integration

The Fermentation Monitor QWX43 uses:

- Direct connection protocol: TCP/IP
- Application layer protocol: TCP/IP-based Open User Communication (OUC)
- Function blocks for Siemens PLCs and Add-on Instructions (AOIs) for Rockwell PLCs

Function blocks for Siemens S7 PLCs:

- SIMATIC S7-300 and S7-400, compatible with STEP V5.5 and higher
- SIMATIC S7-1500, compatible with TIA Portal V15-V17
- SIMATIC S7-1500, compatible with TIA Portal V18 and higher

Add-On Instructions (AOIs) for Rockwell PLCs:

Rockwell CompactLogix 5370/5380 and ControlLogix 5580, compatible with RSLogix 5000 V18.00.00 and higher and Studio 5000 V21.00.04 and higher



Detailed information and files: www.endress.com (Product page > Documents > Software)

Netilion server platform

The Fermentation Monitor QWX43 uses:

- Internet protocol TCP/IP and the secure transport layer TLS (v1.2)
- Application layer protocol: HTTPS

Information on wireless connection

- Wireless technology: Wi-Fi 2.4 GHz
- Frequency channels: 1 to 13
- Frequency range: 2 401 to 2 483 MHz
- Bandwidth: 20 MHz

- Wi-Fi standard: IEEE 802.11 b/g/n
- Antenna type, external antenna: 2 dBi Gain
- Max. output power: +18.7 dBm(FCC MPE measurement/calculation)

Power supply

Supply voltage

Recommended supply voltage: 24 V DC

Permitted supply voltage: 20 to 35 V DC

The power unit must provide safe electrical separation and be tested to ensure it meets safety requirements (e.g., PELV, SELV, Class 2).

A suitable circuit breaker should be provided for the device in accordance with IEC/EN 61010.

Power consumption

2.4 W

Current consumption

100 mA at 24 V DC

Electrical connection

The device is powered via the M12 plug.

NOTICE

Non-compatible wiring of the customer connecting cable

Device malfunction

- ▶ Ensure that the wiring of the M12 socket of the connecting cable matches the PIN assignment of the M12 plug on the device.
- ▶ Order a suitable connecting cable with plug-in jack with the device → 26.

i You can order a connecting cable with plug-in jack with the device → 26.

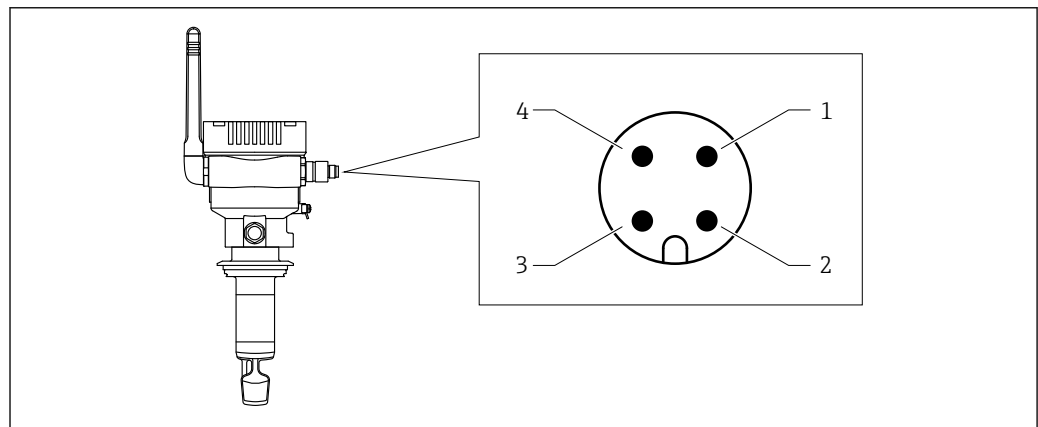

3 PIN assignment of M12 plug, M12 plug mounted on the device

- 1 Minus (-), blue
- 2 N.C.
- 3 Plus (+), brown
- 4 Shielding

i Position the connecting cable so that it is pointing downwards to ensure that no moisture can penetrate the connection compartment.

If necessary, create a drip loop or use a weather protection cover.

Overvoltage protection

Overvoltage protection must be installed on the customer side in the following cases:

- The power supply line to the Fermentation Monitor is longer than 30 meters
- The power supply line to the Fermentation Monitor goes outside the building
- Other devices are connected to the supply unit for the Fermentation Monitor in parallel

Install the overvoltage protection as close as possible to the Fermentation Monitor.

You can use the Endress+Hauser HAW569 or HAW562 modules, for example, for overvoltage protection.

The proposed overvoltage protection is included with the Fermentation Monitor QWX43 when delivered.

Performance characteristics

Response time	20 s
Reference conditions	<ul style="list-style-type: none"> ■ Distilled water, degassed: +10 °C (+50 °F) ■ Density: 999.7 kg/m³ ■ Atmospheric pressure: constant in the range of 860 to 1060 mbar (12.47 to 15.37 psi)
Measured value resolution	<ul style="list-style-type: none"> ■ Viscosity: 0.01 mPa·s ■ Density: 0.0001 g/cm³ ■ Temperature: 0.01 °C ■ Sound velocity: 0.05 m/s
Measurement error	<p>As per DIN EN IEC 62828-1. The measurement error satisfies ± 2 sigma.</p> <p>Under reference conditions</p> <ul style="list-style-type: none"> ■ Viscosity: 0.02 mPa·s ■ Density: 0.0001 g/cm³ ■ Temperature: 0.08 °C ■ Sound velocity: 0.23 m/s <p>Resulting measurement errors</p> <ul style="list-style-type: none"> ■ Extract: 0.02 %mass ■ Extract: 0.02 °Plato ■ Alcohol: 0.02 %vol
Repeatability	<p>As per DIN EN IEC 62828-1. The repeatability satisfies ± 2 sigma.</p> <p>Under reference conditions</p> <ul style="list-style-type: none"> ■ Viscosity: 0.01 mPa·s ■ Density: 0.00006 g/cm³ ■ Temperature: 0.05 °C ■ Sound velocity: 0.06 m/s <p>Resulting measurement errors</p> <ul style="list-style-type: none"> ■ Extract: 0.01 %mass ■ Extract: 0.01 °Plato ■ Alcohol: 0.01 %vol
Measurement uncertainty	<p>Under reference conditions</p> <ul style="list-style-type: none"> ■ Viscosity: 0.02 mPa·s ■ Density: 0.00008 g/cm³ ■ Temperature: 0.07 °C ■ Sound velocity: 0.14 m/s <p>Resulting measurement uncertainties</p> <ul style="list-style-type: none"> ■ Extract: 0.02 %mass ■ Extract: 0.02 °Plato ■ Alcohol: 0.02 %vol
Design fundamentals	<p>The measured process density is primarily used to calculate process variables that are referred to as "apparent" variables. For example, the process density can be used in the "Balling formula" to calculate the alcohol content (according to Balling).</p> <p>Balling formula: $P = ((A * 2.0665 + Wr) * 100\%) / (100 + A * 1.0665)$</p> <ul style="list-style-type: none"> ■ P: original gravity ■ Wr: actual residual gravity in %mass ■ A: alcohol content in %mass
Vibration effects	<p>Mount the device in such a way that the device is not exposed to any vibrations. Vibrations affect the accuracy of the measured value.</p>

Mounting

Mounting location

Recommended mounting locations

- On the side of the tank (horizontal orientation)
- Minimum distance of sensor tip to tank wall: 10 cm (3.94 inch)
- The measuring elements must be fully immersed in the medium
- The measuring elements should be in the bottom third of the tank but above the cone for optimized measurement during fermentation

An engraved marking on the device neck indicates the correct alignment of the measuring elements for mounting.

Avoid the following mounting locations

Mounting locations where a buildup of yeast or gas is likely to occur such as at the bottom of the tank or near the filling limit for example

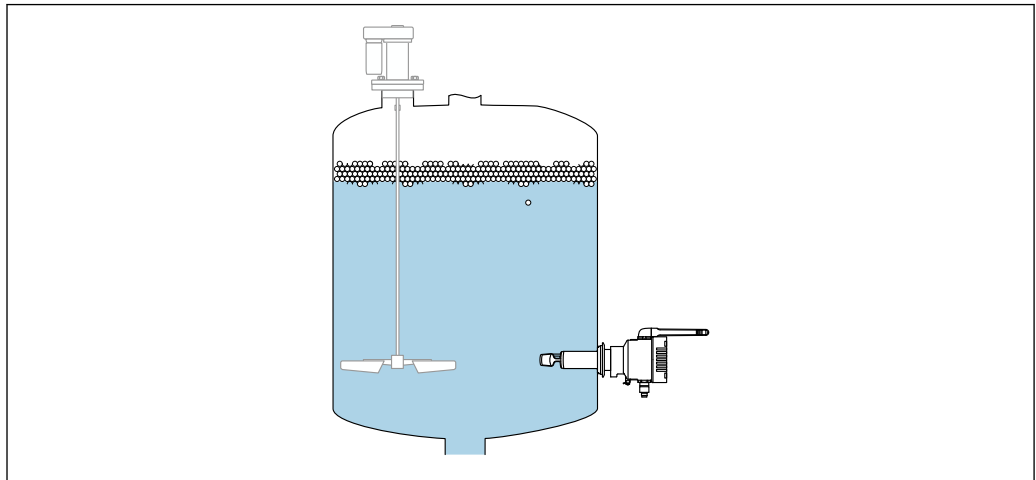

A0055886

4 Possible orientation

Installation instructions

Take clearance into consideration

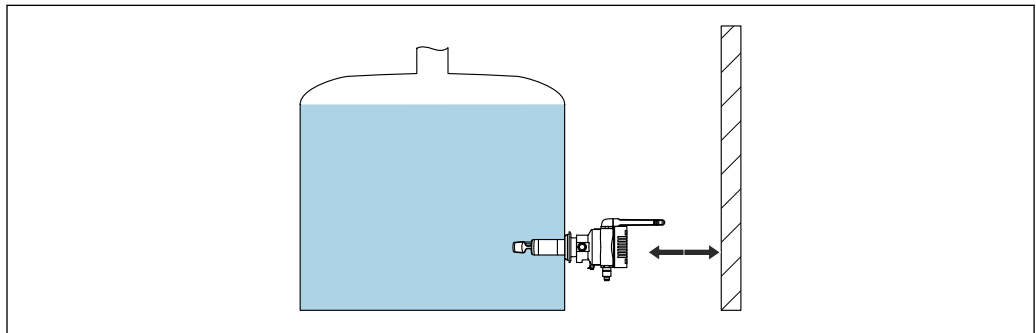

A0055886

5 Take clearance into consideration

Allow sufficient space for mounting and electrical connection.

M12 connector

The M12 connector is used to supply power to the device.

- i** Position the connecting cable so that it is pointing downwards to ensure that no moisture can penetrate the connection compartment.

If necessary, create a drip loop or use a weather protection cover.

Aligning the housing

The housing can be rotated after releasing the hexagonal-headed bolt on the device neck. This allows you to align the connection and the antenna.

Positioning the antenna

To optimize the transmission quality, position the antenna in such a way that it is not emitting its signal directly on metal. You can rotate the antenna within an angle of 270°.

NOTICE

Angle of rotation of antenna too large!

Damage to internal wiring.

- ▶ Rotate the antenna within a maximum angle of 270°.

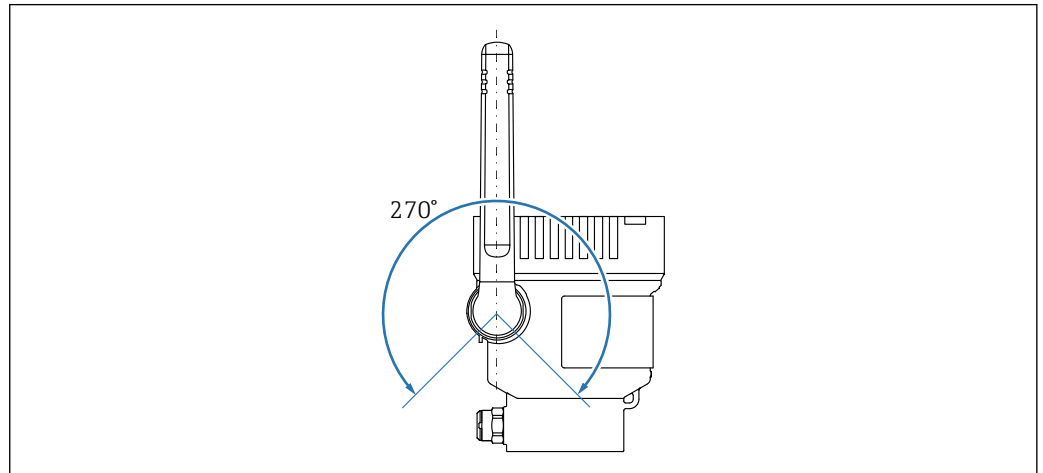

 6 Possible angle of rotation of the antenna

A0046889

Remote antenna for Fermentation Monitor QWX43

Special version TSP no.: 71641142

Endress+Hauser offers a version with remote antenna for mounting on tanks that are set up outdoors and have a 360° metal shielded mounting location for the device to enable an undisturbed transmission path. Please contact your Endress+Hauser sales representative for further information.

Wireless access point for direct integration version

Note the following for the mounting location:

- If possible, mount the wireless access point on a ceiling
- If possible, ensure clear, unobstructed visibility between the Fermentation Monitor and the wireless access point
- Maximum distance between the Fermentation Monitor and the wireless access point without additional interference influences: 25 m
- Align the antenna of the Fermentation Monitor and the antenna of the wireless access point parallel to each other.
- If installing outdoors, protect the wireless access point from the effects of the weather, e.g. use a housing

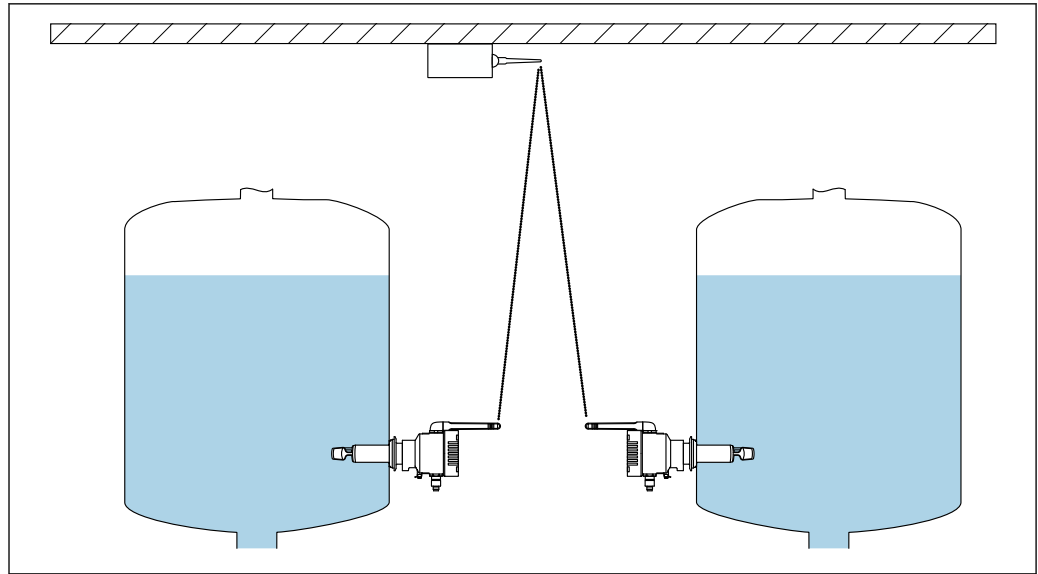

A0052180

7 Recommendations for the wireless access point mounting location

Environment

Ambient temperature range	<p>–20 to +60 °C (–4 to +140 °F)</p> <p>The device is also suitable for outdoor operation.</p> <p>Outdoor operation in strong sunlight:</p> <ul style="list-style-type: none"> ■ Mount the device in the shade. ■ Avoid direct sunlight, particularly in warmer climactic regions. ■ Use a weather protection cover.
Storage temperature	<p> Store indoors if possible</p> <p>–20 to +60 °C (–4 to +140 °F)</p>
Operating height	<p>As per IEC 61010-1 Ed.3: 2 000 m (6 562 ft) above sea level</p>
Humidity	<p>Operate up to 100%. Do not open in a condensing atmosphere.</p>
Climate class	<p>As per IEC 60068-2-38 test Z/AD</p>
Degree of protection	<p>IP66/67, NEMA Type 4X</p> <p>IP66/67</p> <ul style="list-style-type: none"> ■ Complete protection against contact and complete protection against dust (dust-proof) ■ Protected against powerful water jets or protected against temporary immersion in water <p>NEMA Type 4X Indoor or outdoor installation, protects against windblown dust and rain, splashing water, water jets and corrosion</p>
Shock and vibration resistant	<p>Vibration resistance according to EN60068-2-64 and shock resistance according to DIN EN60068-2-27</p>
Mechanical stress	<p>NOTICE</p> <p>Mechanical deformation of the fork tines or shocks to the fork tines Device malfunction, e.g. impacting the measurement accuracy</p> <ul style="list-style-type: none"> ▶ Protect the fork tines against mechanical deformation. ▶ Avoid impact on the fork tines.
Internal cleaning	<p>CIP cleaning</p> <p>Suitable for CIP cleaning with a constant temperature of 110 °C (230 °F) maximum</p>
Electromagnetic compatibility (EMC)	<p>As per IEC/EN 61326 series</p> <p>Overvoltage category II</p> <p>Maximum deviation under interference influence: < 1 % of measuring range</p> <p>Overvoltage protection must be installed at the customer site in the following cases:</p> <ul style="list-style-type: none"> ■ The power supply line to the Fermentation Monitor is longer than 30 meters. ■ The power supply line to the Fermentation Monitor leaves the building. ■ Other consumers are connected in parallel to the power supply unit for the Fermentation Monitor. <p>Install the overvoltage protection as close to the Fermentation Monitor as possible.</p> <p>You can install Endress+Hauser surge arresters HAW569 or HAW562, for example, as an overvoltage protection.</p>

Process

Process temperature range -10 to +110 °C (+14 to +230 °F)

Process pressure range 0 to 16 bar (0 to 232.1 psi) depending on the selected process connection and possible certificate-related restrictions (e.g. CRN)

Mechanical construction

Design, dimensions

Device height

The device height is calculated from the following components:

- Housing including cover
- Antenna
- Process connection
- Probe design: compact version or pipe extension



You can rotate the antenna.

The individual heights of the components can be found in the following sections:

- Determine the height of the device and add the individual heights.
- Take the installation space into account (the space required to install the device)

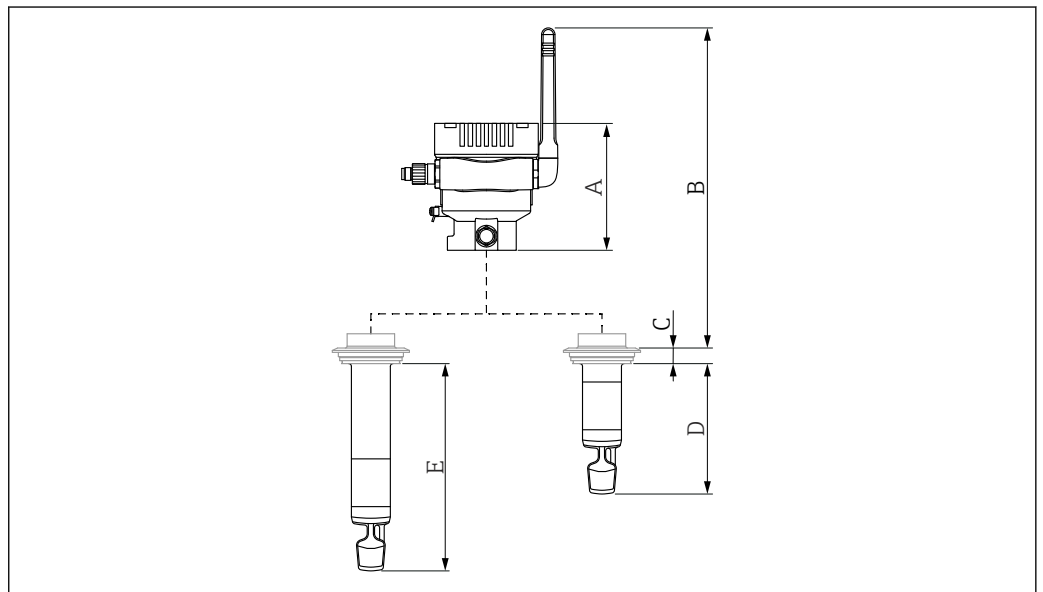

A0046639

8 Components for determining the height of the device

- A Housing including cover
- B Maximum height of housing with antenna
- C Height of process connection
- D Probe design: compact version
- E Probe design: pipe extension

Dimensions

Housing

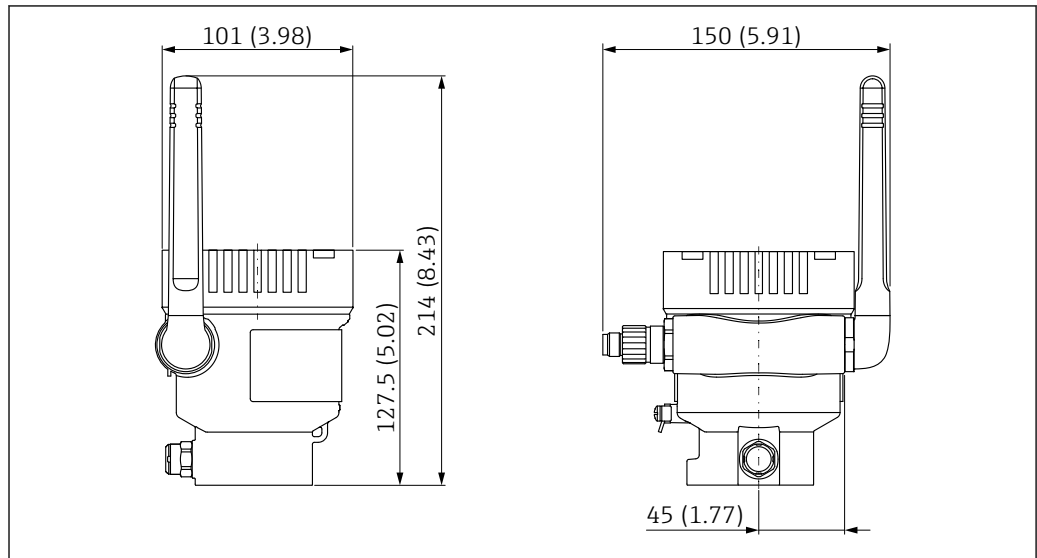

A0045366

9 Single compartment housing. Unit of measurement mm (in)

Probe design

Compact version

Material: 316L

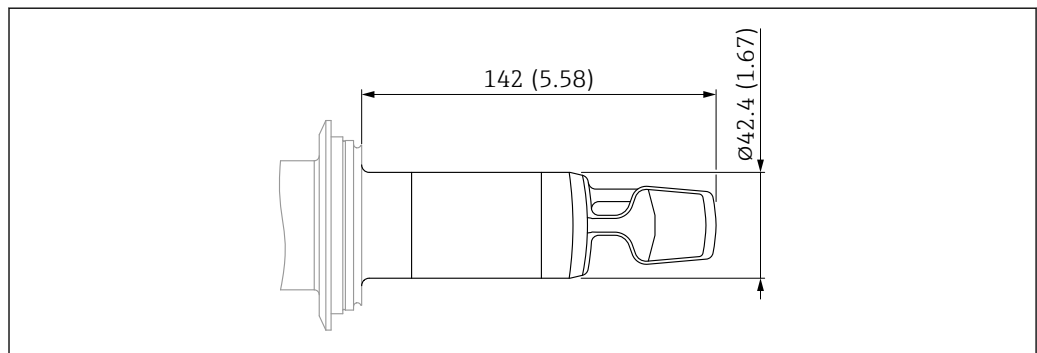

A0046702

10 Probe design: compact version. Unit of measurement mm (in)

Pipe extension

Material: 316L

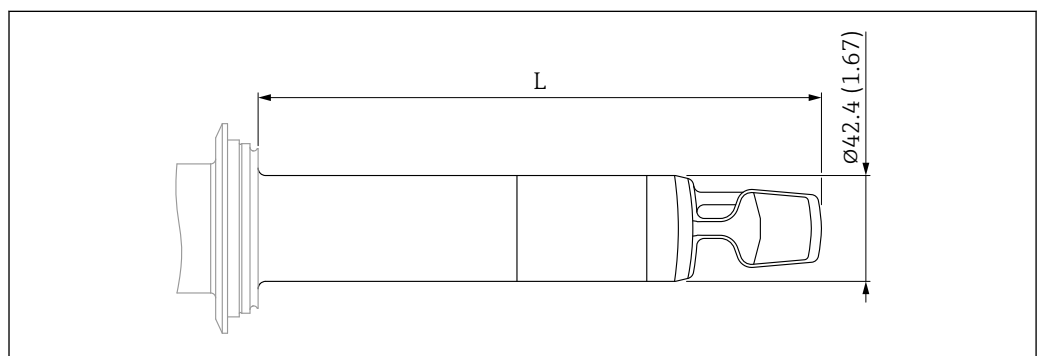

A0046703

11 Probe design: pipe extension. Unit of measurement mm (in)

L Sensor length

Sensor length L

- 280 mm (11.0) for use in non-flush tank connections such as Tri-Clamp or DIN11851
- 400 mm (15.8 in)
- 1000 mm (39.4 in)
- 1500 mm (59.1 in)
- 2000 mm (78.7 in)

Measuring elements

Material: 316L

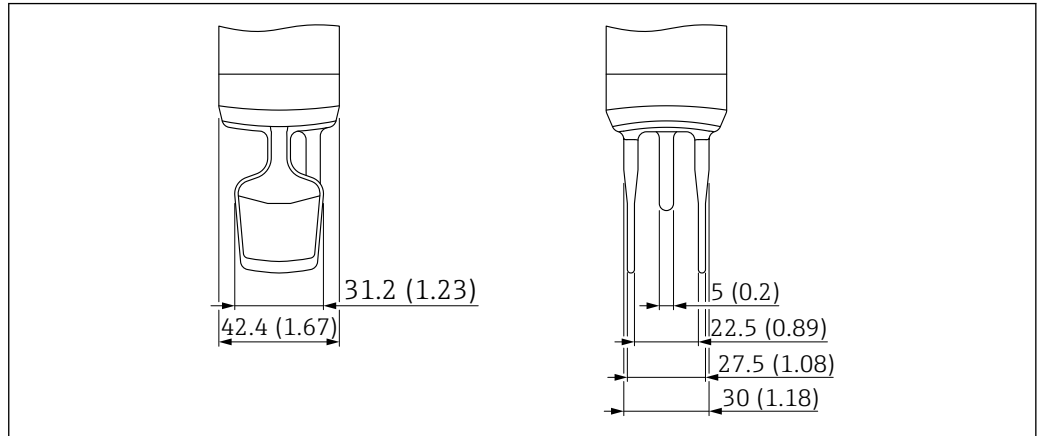

12 Measuring elements. Unit of measurement mm (in)

Process connections

Material: 316L

Varivent N DN50 PN40

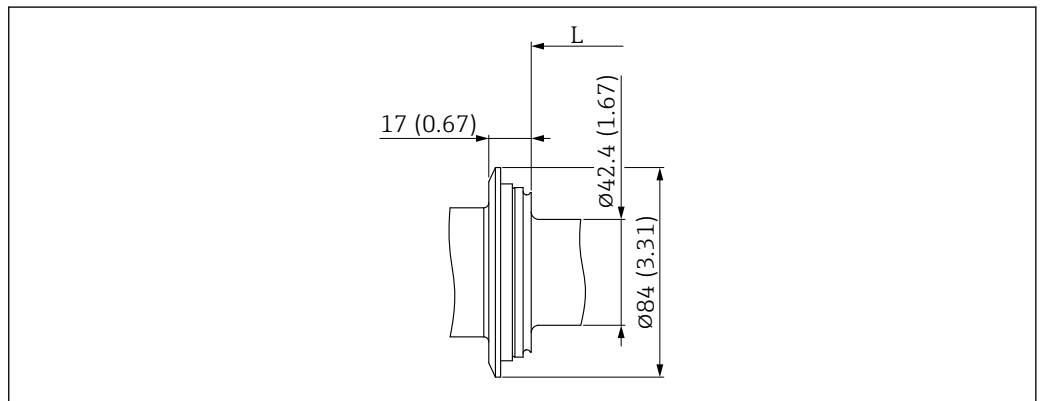

13 Varivent N DN50 PN40. Unit of measurement mm (in)

Tri-Clamp 2"

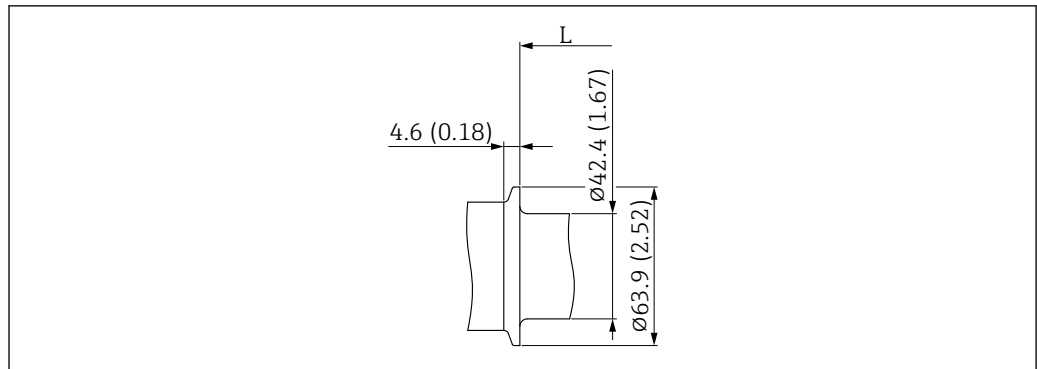

A0046706

14 Tri-Clamp 2". Unit of measurement mm (in)

2.5" Tri-Clamp

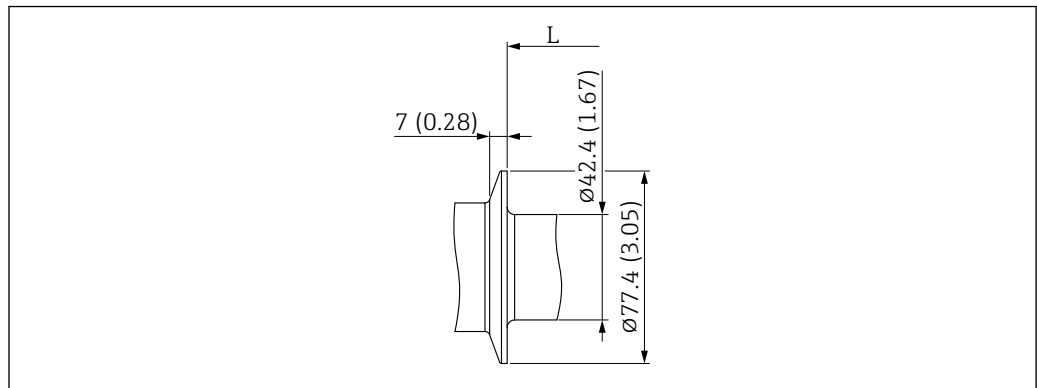

A0046707

15 2.5" Tri-Clamp. Unit of measurement mm (in)

4" Tri-Clamp

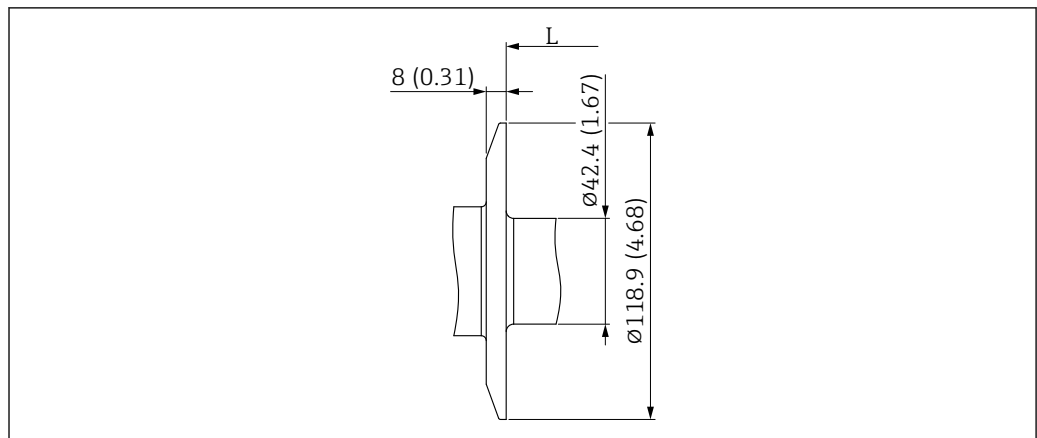

A0046708

16 4" Tri-Clamp . Unit of measurement mm (in)

DIN11851 DN50 PN25

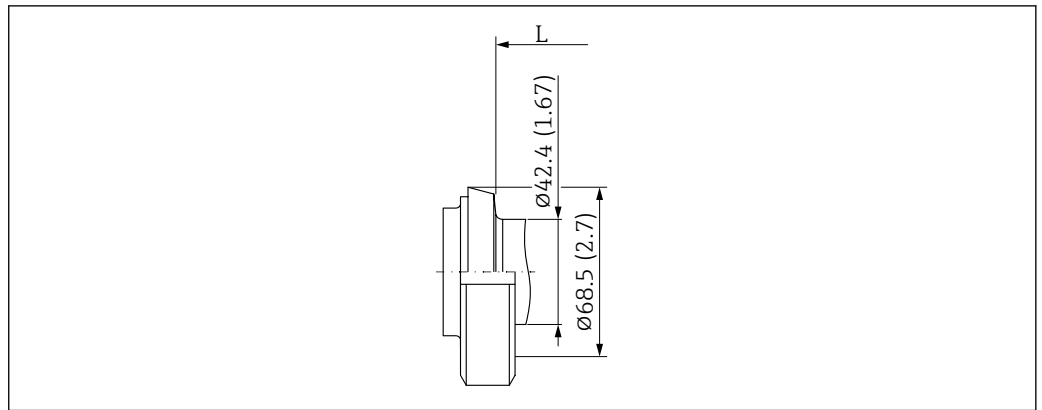

A0046709

17 DIN11851 DN50 PN25. Unit of measurement mm (in)

DRD DN50 PN25

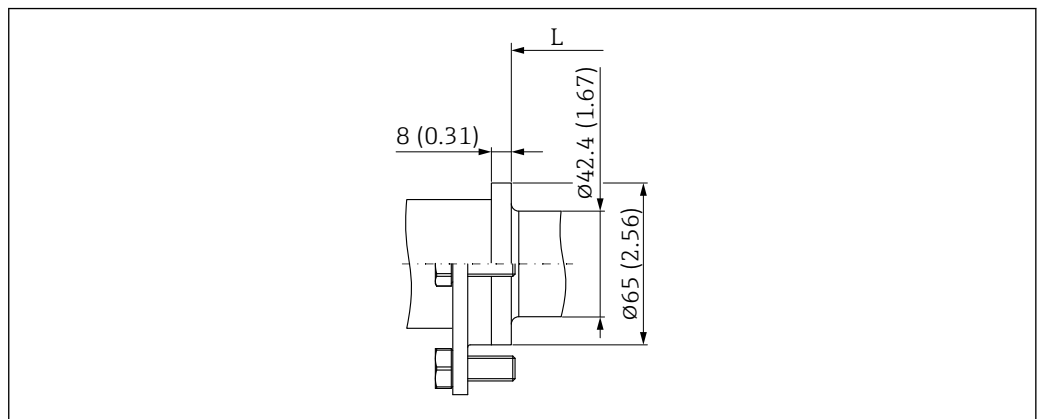

A0046710

18 DRD DN50 PN25. Unit of measurement mm (in)

Weight

- Compact version with Varivent N process connection: approx. 2.5 kg (5.5 lb)
- Pipe extension 1000 mm, additional weight: approx. 2 kg (4.4 lb)

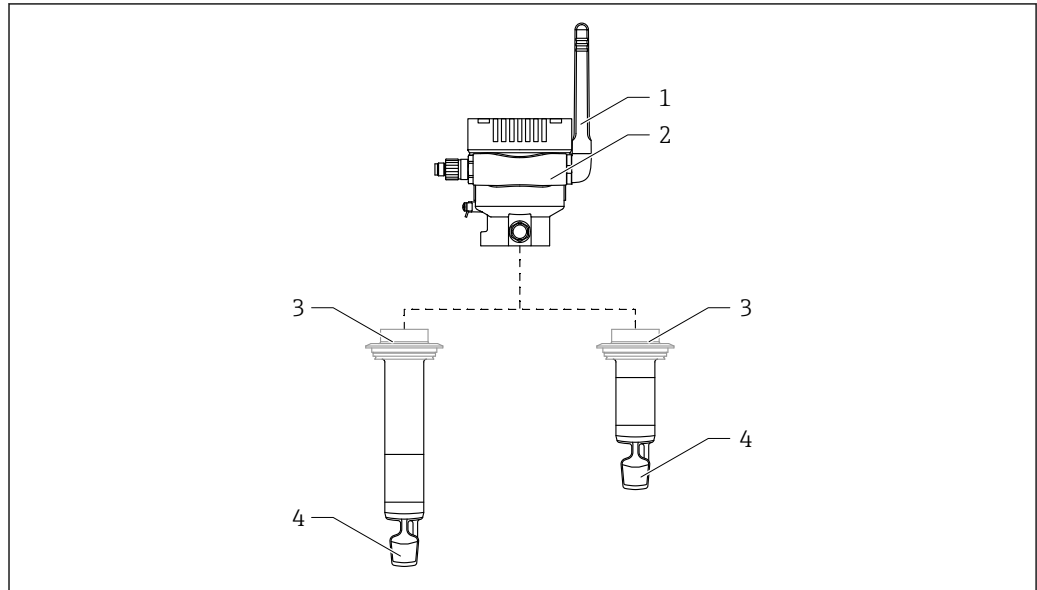
Materials**19 Materials**

- 1 Omnidirectional dipole antenna: polyester
- 2 Single-compartment housing with cover: polyester powder coating on aluminum as per EN 1706 AC-43400, adhesive label made of plastic
- 3 Process connection: 1.4404/316L
- 4 Measuring elements: 1.4404/316L

Also for versions with pipe extension: filler metal 1.4430

Surface roughness

Ra: < 0.76 µm of wetted surfaces

Operability

Direct integration

The device does not have a display. It has LEDs that provide feedback signals. Operating keys are available for maintenance work.

All read and write parameters are provided via a data module/function block for the automation system for further processing.



Protocol-specific data: → 📄 10



Detailed information and files: www.endress.com (Product page > Documents > Software)

Netilion server platform

The device does not have a display. It has LEDs that provide feedback signals. Operating keys are available for maintenance work.

Once the device is supplied with voltage and logged onto the Endress+Hauser Netilion server platform via WLAN, the measured data are transmitted immediately to Netilion. The device is connected to the Endress+Hauser Netilion server platform via the customer's WLAN. You can configure and operate the device using the Netilion Fermentation app.



- Detailed information on the Netilion server platform: <https://netilion.endress.com>
- Detailed information on Netilion Fermentation: <https://Netilion.endress.com/app/fermentation>
- Netilion Help & Learning (Troubleshooting, Tips & Tutorials, Getting Started: <https://help.netilion.endress.com>)

Certificates and approvals

Current certificates and approvals for the product are available at www.endress.com on the relevant product page:

1. Select the product using the filters and search field.
2. Open the product page.
3. Select **Downloads**.

CE mark	The device meets the legal requirements of the relevant EU/EC directives. Endress+Hauser confirms successful testing of the device by affixing to it the CE mark.
Sanitary compatibility	<p>All materials in contact with foodstuffs comply with framework regulation (EC) 1935/2004. The device is available with hygienic process connections (overview: see order code).</p> <p>The Fermentation Monitor QWX43 meets the hygiene requirements for food processing machinery as per EN 1672-2:2005+A1:2009. The product is designed in accordance with EHEDG hygienic design principles.</p>
3-A	The device is 3-A certified.
Radio approvals	<p>The relevant radio approval is available for the following countries:</p> <p>Europe, USA, Canada, Argentina, Australia, Bolivia, Brazil, Chile, China, Ecuador, India, Japan, Colombia, Laos, Malaysia, Mexico, Nepal, New Zealand, Panama, Paraguay, Peru, Republic of Korea, South Africa, Thailand, Uruguay, Vietnam</p>

Accessories

- Weather protection cover for single-compartment housing**
- Material: plastic
 - Order number: 71438291

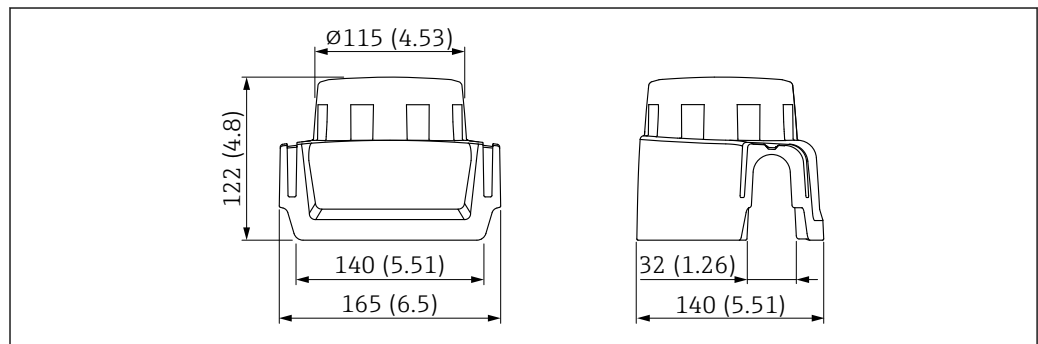

20 Weather protection cover for single-compartment housing. Unit of measurement mm (in)

- Plug-in jack with connecting cable**
- You can order the plug-in jack with the device.

Ordering information: → 27

Plug-in jack M12 IP67

- Elbowed 90°
- 5 m (16 ft) PVC cable (gray)
- Slotted nut Cu Sn/Ni
- Body: PUR (black)
- Operating temperature range: -25 to +70 °C (-13 to +158 °F)
- Order number: 52010285

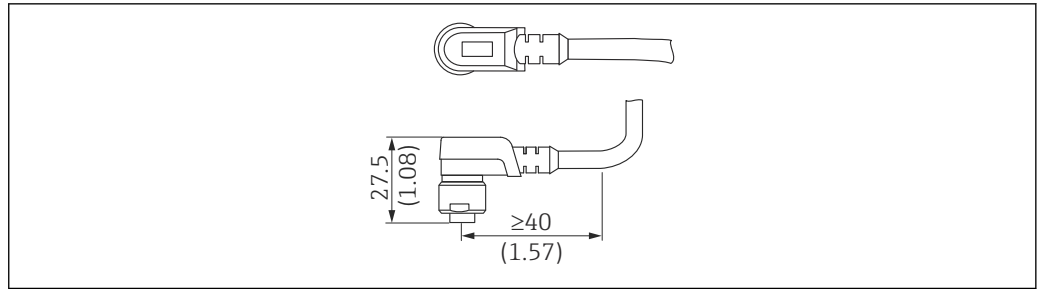

A002292

21 Plug-in jack M12 IP67. Unit of measurement mm (in)

Wireless access point for direct integration version

i Accessories for the "direct integration" version. You can order a wireless access point as an "enclosed accessory".

Ordering information: → **27**

Power supply

- Supply voltage: 100 to 240 VAC
- Input voltage: 9 to 30 VDC via power unit supplied
- Power consumption: < 5 W

Environment

- Operating temperature: -40 to +75 °C (-40 to +167 °F)
- Storage temperature: -45 to +80 °C (-49 to +176 °F)
- Relative humidity (operation): 10 % to 90 % non-condensating
- Relative humidity (storage): 5 % to 95 % non-condensating

Mechanical construction

- Dimensions (width x depth x height): 83 mm x 74 mm x 25 mm
- Weight: 125 g

i Pay attention to the installation instructions: → **15**

Ordering information

Detailed ordering information is available from your nearest sales organization www.addresses.endress.com or in the Product Configuration at www.endress.com :

1. Click Corporate
2. Select the country
3. Click Products
4. Select the product using the filters and search field
5. Open the product page

The Configuration button to the right of the product image opens the Product Configurator.

i **Product Configurator - the tool for individual product configuration**

- Up-to-the-minute configuration data
- Depending on the device: direct input of information specific to the measuring point, such as the measuring range or operating language
- Automatic verification of exclusion criteria
- Automatic creation of the order code and its breakdown in PDF or Excel output format
- Ability to order directly in the Endress+Hauser Online Shop

Scope of delivery

Fermentation Monitor QWX43

Supplementary documentation

All associated documents for the Fermentation Monitor QWX43 are available in the download area of the Endress+Hauser web site (www.endress.com/downloads).



For an overview of the scope of the associated Technical Documentation, refer to the following:

- *Device Viewer* (www.endress.com/deviceviewer): Enter the serial number from the nameplate
- *Endress+Hauser Operations app*: Enter serial number from nameplate or scan matrix code on nameplate.

Standard documentation
QWX43

Operating Instructions
BA02162F

Special Documentation
SD02875F: Commissioning, safety instructions and radio approvals

Registered trademarks

TRI-CLAMP®

Registered trademark of Ladish & Co., Inc., Kenosha, USA

VARIVENT® N

Registered trademark of GEA Group AG, Düsseldorf, Germany



71705262

www.addresses.endress.com
