

Functional Safety Manual

Micropilot

FMR50/51/52/53/54/56/57

Functional Safety Manual



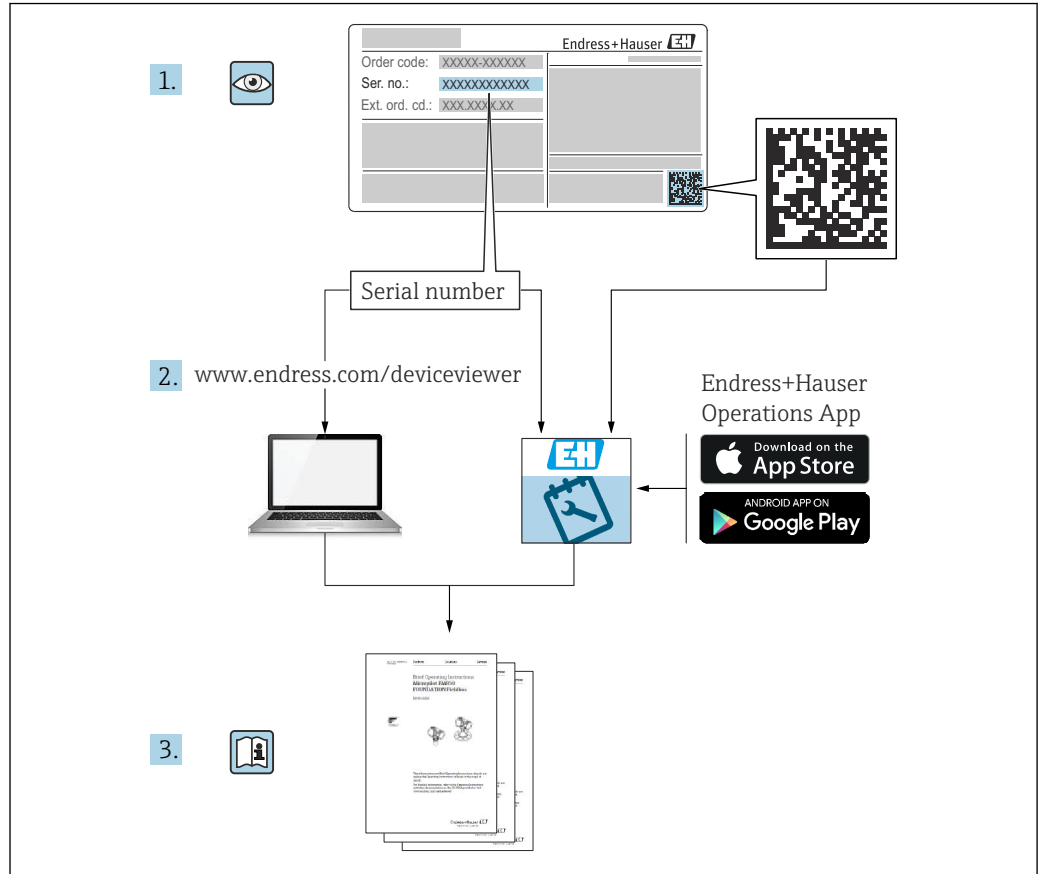

A0023555

Table of contents

1	Declaration of Conformity	4	6.6	Repairs	31
1.1	Other safety-related characteristic values	5	6.7	Modification	32
1.2	Useful lifetime of electrical components	6	7	Appendix	33
2	Document information	7	7.1	Structure of the measuring system	33
2.1	Document function	7	7.1.1	System components	33
2.2	Using this document	7	7.1.2	Description of use as a protective system	33
2.2.1	Information on the document structure	7	7.2	Proof-testing	35
2.3	Symbols used	7	7.3	Notes on the redundant use of multiple sensors	35
2.3.1	Safety symbols	7	7.4	Further information	36
2.3.2	Symbols for certain types of information	7			
2.3.3	Symbols in graphics	8			
2.4	Supplementary device documentation	8			
3	Permitted device types	9			
3.1	SIL label on the nameplate	10			
4	Safety function	10			
4.1	Definition of the safety function	10			
4.2	Safety-related signal	10			
4.3	Restrictions for use in safety-related applications	11			
4.3.1	Dangerous undetected failures in this scenario	12			
5	Use in protective systems	13			
5.1	Device behavior during operation	13			
5.1.1	Device behavior in SIL-locked state ...	13			
5.1.2	Device behavior during power-up ...	13			
5.1.3	Device behavior in safety function demand mode	13			
5.1.4	Device behavior in event of alarms and warnings	13			
5.1.5	Alarm and warning messages	13			
5.2	Parameter configuration for safety-related applications	14			
5.2.1	Calibration of the measuring point ...	14			
5.2.2	Methods of device configuration ...	14			
5.3	Proof-testing	23			
5.3.1	Test sequence A	24			
5.3.2	Test sequence B	25			
5.3.3	Test sequence C	26			
5.3.4	Test sequence D	28			
6	Life cycle	30			
6.1	Requirements for personnel	30			
6.2	Installation	30			
6.3	Commissioning	30			
6.4	Operation	30			
6.5	Maintenance	30			

1 Declaration of Conformity

SIL_00246_03.26

Endress+Hauser 
People for Process Automation

Declaration of Conformity

Functional Safety according to IEC 61508

Based on NE 130 Form B.1

Endress+Hauser SE+Co. KG, Hauptstraße 1, 79689 Maulburg

being the manufacturer, declares that the product

Micropilot FMR5x

is suitable for the use in safety-instrumented systems according to IEC 61508. The instructions of the corresponding functional safety manual must be followed.

This declaration of conformity is exclusively valid for the listed products and accessories in delivery status.

Maulburg, January 15, 2026
Endress+Hauser SE+Co. KG

i. V.

E-SIGNED by Simon Greth
on 15 January 2026 10:40:25 CET

Simon Greth
Dept. Man. R&D Devices Level Continuous
Research & Development

i. V.

E-SIGNED by Stefan Jäger
on 15 January 2026 10:18:03 CET

Stefan Jäger
Dept. Man. R&D Quality Management/FSM
Research & Development

A0036048

SIL_00246_03.26



General			
Device designation and permissible types ¹⁾	Micropilot FMR5x ** A,B,C,K * * * * * ** + [LA]		
	x = 0, 1, 2, 3, 4, 6, 7		
Safety-related output signal	4...20 mA		
Fault signal	≤ 3.6 mA / ≥ 21 mA		
Process variable/function	Level measurement		
Safety function(s)	MIN / MAX / RANGE		
Device type acc. to IEC 61508-2	<input type="checkbox"/> Type A	<input checked="" type="checkbox"/> Type B	
Operating mode	<input checked="" type="checkbox"/> Low Demand Mode	<input checked="" type="checkbox"/> High Demand or Continuous Mode	
Valid hardware version	Manufacturing date after Dec. 17,2012		
Valid software version	As of version 01.00.zz (zz: any number)		
Safety manual	FY01097F		
Type of evaluation (check only <u>one</u> box)	<input checked="" type="checkbox"/>	Complete HW/SW evaluation parallel to development incl. FMEDA and change request acc. to IEC 61508-2, 3	
	<input type="checkbox"/>	Evaluation of "proven in use" performance for HW/SW incl. FMEDA and change request acc. to IEC 61508-2, 3	
	<input type="checkbox"/>	Evaluation of HW/SW field data to verify „prior use“ acc. to IEC 61511	
	<input type="checkbox"/>	Evaluation by FMEDA acc. to IEC 61508-2 for devices w/o software	
Evaluation through – report/certificate no.	TÜV Rheinland 968/EL 882		
Test documents	Development documents	Test reports	Data sheets
SIL – Integrity			
Systematic safety integrity		<input type="checkbox"/> SC 2	<input checked="" type="checkbox"/> SC 3
Hardware safety integrity	Single channel use (HFT = 0)	<input checked="" type="checkbox"/> SIL 2 capable	<input type="checkbox"/> SIL 3 capable
	Multi channel use (HFT ≥ 1)	<input type="checkbox"/> SIL 2 capable	<input checked="" type="checkbox"/> SIL 3 capable
FMEDA			
Safety function	MIN	MAX	RANGE
$\lambda_{DU}^{2),3)}$	243 FIT	243 FIT	243 FIT
$\lambda_{DD}^{2),3)}$	2653 FIT	2653 FIT	2653 FIT
$\lambda_S^{2),3)}$	768 FIT	768 FIT	768 FIT
SFF	93%	93%	93%
PFD _{avg} (T ₁ = 1 year) ³⁾ (single channel architecture)	1.08 · 10 ⁻³	1.08 · 10 ⁻³	1.08 · 10 ⁻³
PFH	2.43 · 10 ⁻⁷ 1/h	2.43 · 10 ⁻⁷ 1/h	2.43 · 10 ⁻⁷ 1/h
PTC ⁴⁾ A / B / C / D	99% / 99% / 56% / 93%	99% / 99% / 56% / 93%	99% / 99% / 56% / 93%
Diagnostic test interval ⁵⁾	≤ 30 min	≤ 30 min	≤ 30 min
Fault reaction time ⁶⁾	≤ 30 s	≤ 30 s	≤ 30 s
Comments			
-			
Declaration			
<input checked="" type="checkbox"/>	Our internal company quality management system ensures information on safety-related systematic faults which become evident in the future		

¹⁾ Valid order codes and order code exclusions are maintained in the E+H ordering system
²⁾ FIT = Failure In Time, number of failures per 10⁹ h
³⁾ Valid for average ambient temperature up to +40 °C (+104 °F)
 For continuous operation at ambient temperature close to +60 °C (+140 °F), a factor of 2.1 should be applied
⁴⁾ PTC = Proof Test Coverage
⁵⁾ All diagnostic functions are performed at least once within the diagnostic test interval
⁶⁾ Maximum time between error recognition and error response

A0036049

1.1 Other safety-related characteristic values

Characteristic value as per IEC 61508

System reaction time as per DIN EN 61298-2

In "Increased safety mode":

For "Medium type = Liquid":

Depends on the "Tank type" parameter:

- "Workbench test" (not recommended during operation): < 1 s
- "Bypass/pipe": < 8 s
- "Storage vessel": <50 s
- all others: <20 s

For "Medium type = Solid":

Depending on the "Max. filling speed" and "Max. draining speed" parameters, for filling or draining respectively:

- "No filter/test" (not recommended during operation): 1 s
- "Very fast >8 m (26 ft)/h": <10 s
- "Fast <8 m (26 ft)/h": <75 s
- "Medium <4 m (13 ft)/h": <170 s
- "Standard <2 m (6.6 ft)/h": <340 s
- "Slow <1 m (3.3 ft)/h": <730 s
- "Very slow <0.5 m (1.6 ft)/h": <910 s

In "Expert mode":

Free configurable, shortest response time:

For level measurement: 1 s

1.2 Useful lifetime of electrical components

The established failure rates of electrical components apply within the useful lifetime as per IEC 61508-2:2010, section 7.4.9.5, note 3. In accordance with DIN EN 61508-2:2011, section 7.4.9.5, national footnote N3, appropriate measures taken by the manufacturer and operator can extend the useful lifetime.

2 Document information

2.1 Document function

The document is part of the Operating Instructions and serves as a reference for application-specific parameters and notes.

-  General information about functional safety: SIL
- General information about SIL is available:
In the Download Area of the Endress+Hauser Internet site:
www.de.endress.com/SIL





2.2 Using this document

2.2.1 Information on the document structure





 For the arrangement of the parameters as per the **Operation** menu, **Setup** menu, **Diagnostics** menu, along with a short description, see the Operating Instructions for the device

2.3 Symbols used

2.3.1 Safety symbols

Symbol	Meaning
	DANGER! This symbol alerts you to a dangerous situation. Failure to avoid this situation will result in serious or fatal injury.
	WARNING! This symbol alerts you to a dangerous situation. Failure to avoid this situation can result in serious or fatal injury.
	CAUTION! This symbol alerts you to a dangerous situation. Failure to avoid this situation can result in minor or medium injury.
	NOTE! This symbol contains information on procedures and other facts which do not result in personal injury.

2.3.2 Symbols for certain types of information

Symbol	Meaning
 <small>A0011193</small>	Tip Indicates additional information.
	Reference to documentation
	Reference to page
	Reference to graphic
	Series of steps

2.3.3 Symbols in graphics

Symbol	Meaning
1, 2, 3,...	Item numbers
1, 2, 3...	Series of steps
A, B, C, ...	Views

2.4 Supplementary device documentation

Micropilot FMR50, FMR51, FMR52, FMR53, FMR54, FMR56, FMR57

Documentation	Comment
Technical Information: <ul style="list-style-type: none"> ■ TI01039F/00 (FMR50) ■ TI01040F/00 (FMR51/52) ■ TI01041F/00 (FMR53/54) ■ TI01042F/00 (FMR56/57) 	The documentation is available on the Internet: → www.endress.com
Operating Instructions (HART): <ul style="list-style-type: none"> ■ BA01045F/00 (FMR50) ■ BA01049F/00 (FMR51/52) ■ BA01050F/00 (FMR53/54) ■ BA01048F/00 (FMR56/57) 	The documentation is available on the Internet: → www.endress.com
Brief Operating Instructions (HART): <ul style="list-style-type: none"> ■ KA01099F/00 (FMR50) ■ KA01100F/00 (FMR51/52) ■ KA01101F/00 (FMR53/54) ■ KA01102F/00 (FMR56/57) 	<ul style="list-style-type: none"> ■ The document is provided with the device. ■ The documentation is available on the Internet: → www.endress.com
Description of Device Parameters: GP01014F/00	The documentation is available on the Internet: → www.endress.com
Safety instructions depending on the selected option "Approval".	Additional safety instructions (XA, ZE) are supplied with certified device version. Please refer to the nameplate for the relevant safety instructions.



This supplementary Safety Manual applies in addition to the Operating Instructions, Technical Information and ATEX Safety Instructions. The supplementary device documentation must be observed during installation, commissioning and operation. The requirements specific for the protection function are described in this Safety Manual.

3 Permitted device types

The details pertaining to functional safety in this manual relate to the device versions listed below and are valid as of the specified software and hardware version. Unless otherwise specified, all subsequent versions can also be used for safety functions. A modification process according to IEC 61508 is applied for any device modifications.



Valid device versions for safety-related use:

Order code	Designation	Option
010	Approval	all
020	Power Supply; Output	<ul style="list-style-type: none"> ▪ A 2-wire; 4-20 mA HART ▪ B ¹⁾ 2-wire; 4-20 mA HART, switch output ▪ C ²⁾ 2-wire; 4-20 mA HART, 4-20 mA ▪ K 4-wire 90-253 VAC; 4-20 mA HART
030	Display; Operation	all
040	Housing	all
050	Electrical connection	all
070	Antenna	all
090	Seal (only FMR51/54/57)	all
100	Process connection	all
110	Purge-air connection (FMR57 only)	all
500	Additional Operation Language	all
540	Application Package	all
550	Calibration	all
570	Service	all
580	Test; certificate (only FMR51/52/53/54/56)	all
590	Additional Approval	LA ³⁾ SIL
610	Accessory Mounted	all
620	Accessory Enclosed	all
850	Firmware version	<p>If no version is selected here, the latest SW with SIL capability is supplied. Alternatively, the following SW version may be selected:</p> <ul style="list-style-type: none"> ▪ 75 01.01.zz, HART 6, DevRev02 ▪ 72 01.02.zz, HART 7, DevRev03

- 1) In this version with one current output and one switch output, only the current output (terminals 1 and 2) is approved for safety functions. The switching output can, if necessary, be wired for non-safety-oriented purposes.
- 2) In this version with two current outputs, only the first output (terminals 1 and 2) is approved for safety functions. The second output can, if necessary, be wired for non-safety-oriented purposes.
- 3) An additional selection of any additional versions is possible.

- Valid firmware version: as of 01.00.zz (→ nameplate of the device)
- Valid hardware version (electronics): as of date of production 17.12.2012 (→ nameplate of the device)

3.1 SIL label on the nameplate

 SIL certified devices are marked with the following symbol on the nameplate: 

4 Safety function

4.1 Definition of the safety function

The device's safety functions are:

- Maximum level limit monitoring (overflow protection)
- Minimum level limit monitoring (dry run protection)
- Level range monitoring

The safety functions include level measurement of a liquid or bulk solid.

4.2 Safety-related signal

The safety-related signal is the analog output signal: 4 to 20 mA. All safety measures refer to this signal exclusively.

For devices with current output and switch output (ordering feature 020 "Power Supply; Output", option B "2-wire; 4-20 mA HART, switch output"), only the current output (terminals 1 and 2) is approved for safety functions. The switch output (terminals 3 and 4) can, if necessary, be wired for non-safety-oriented purposes.

For devices with two current outputs (ordering feature 020 "Power Supply; Output", option C "2-wire; 4-20 mA HART + 4-20 mA analog"), only the first current output (terminals 1 and 2) is approved for safety functions. The second output (terminals 3 and 4) can, if necessary, be wired for non-safety-oriented purposes.



The device additionally communicates for information only via HART and contains all HART features with additional device information.



The safety-related output signal is fed to a downstream logic unit, e.g. a programmable logic controller or a limit signal transmitter where it is monitored for the following:

- Exceed and/or fall below a specific level limit.
- The occurrence of a fault, e.g. failure current (≤ 3.6 mA, ≥ 21.0 mA, interruption or short-circuit of the signal line).

 In case of fault it must be ensured that the equipment under control achieves or maintains a safe state.

4.3 Restrictions for use in safety-related applications

- The measuring system must be used correctly for the specific application, taken into account the medium properties and ambient conditions. Carefully follow instructions pertaining to critical process situations and installation conditions from the Operating Instructions. The application-specific limits must be observed.
- Information on the safety-related signal, (→  10).
- The specifications from the Operating Instructions must not be exceeded, (→  8).
- The following restrictions also applies to safety-related use:
 - Strong, pulse-like EMC interference on the power supply line can cause transient (< 1 s) deviations $\geq \pm 2\%$ in the output signal. For this reason, filtering with a time constant of ≥ 1 s should be performed in the downstream logic unit.
 - The error range is device specific and is defined according to FMEDA (Failure Modes, Effects and Diagnostic Analysis) on delivery. It includes all influential factors described in the Technical Information (e.g. non-linearity, non-repeatability, hysteresis, zero drift, temperature drift, EMC influences).
According to IEC / EN 61508 the safety related failures are classified into different categories, see the following table. The table shows the implications for the safety related output signal and the measuring uncertainty.

Safety related error	Explanation	Implications for the safety related output signal	Implications for the measuring uncertainty (Position, see figure →  12)
No device error	Safe: No error	None	1 Is within the specification (see TI, BA, ...)
λ_{SD}	Safe detected: Safe failure which can be detected	Causes the output signal to signal the failsafe mode (see, →  13)	3 No implications
λ_{SU}	Safe undetected: Safe failure which cannot be detected	Is within the defined error range	2 May be beyond the specification
λ_{DD}	Dangerous detected: Dangerous failure which can be detected (Diagnostic within the device)	Causes the output signal to signal the failsafe mode (see, →  13)	3 No implications
λ_{DU}	Dangerous undetected: Dangerous failure which cannot be detected	May be outside the defined error range	4 May be outside the defined error range

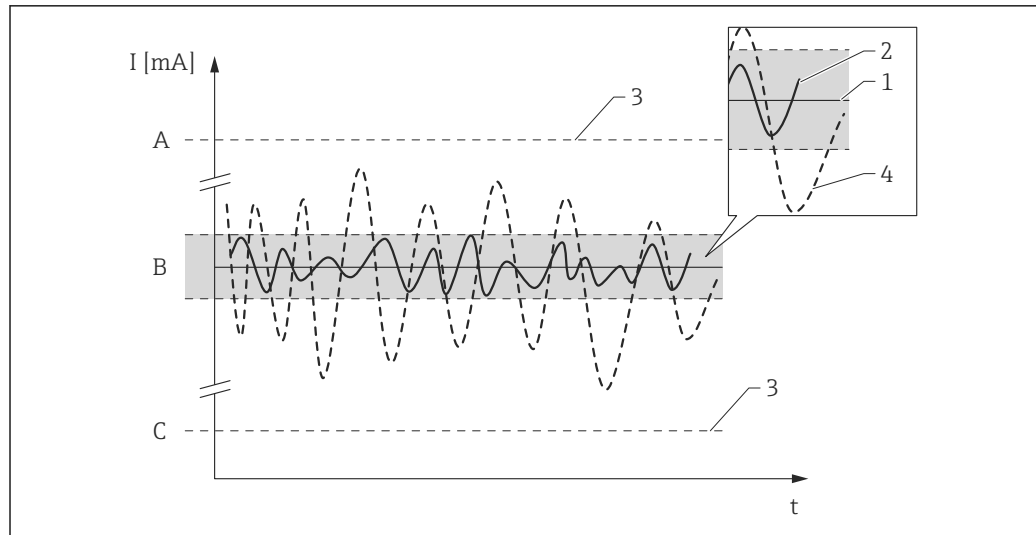

A0025264

- A HI-Alarm ≥ 21 mA
- B Error range ± 2 %
- C LO-Alarm ≤ 3.6 mA



4.3.1 Dangerous undetected failures in this scenario

An incorrect output signal that deviates from the real value by more than 2 % but is still in the range of 4 to 20 mA is considered a dangerous, undetected failure.

5 Use in protective systems

5.1 Device behavior during operation

5.1.1 Device behavior in SIL-locked state

 After SIL locking, additional diagnostics are active and critical parameters in the safety path are set to safe values →  18. Therefore, the behavior of the device in the "SIL-locked state" may deviate from the "non-SIL-locked state". If a test phase takes place before the system is finally put into production, it is recommended that this test phase be run in the locked state in order to obtain the most conclusive results possible.

5.1.2 Device behavior during power-up

Once switched on, the device runs through a diagnostic phase of approx. 30 seconds. The current output is set to failure current during this time. For approx. 5 seconds of this diagnostic phase, this current is ≤ 3.6 mA. After that, depending on the setting of the "Start-up mode" parameter, the current is:

- at the MIN value: ≤ 3.6 mA
- at the MAX value : ≥ 21.0 mA

During the diagnostic phase, no communication is possible via the service interface (CDI) or via HART.

5.1.3 Device behavior in safety function demand mode

The device outputs a current value corresponding to the limit value to be monitored. This value must be monitored and processed further in an attached logic unit.

5.1.4 Device behavior in event of alarms and warnings

The output current on alarm can be set to a value ≤ 3.6 mA or ≥ 21.0 mA.

In some cases (e.g. failure of power supply, a cable open circuit and faults in the current output itself, where the failure current ≥ 21.0 mA cannot be set), output currents ≤ 3.6 mA irrespective of the configured failure current can occur.

In some other cases (e.g. short circuit of cabling), output currents of ≥ 21.0 mA occur irrespective of the configured failure current.

For alarm monitoring, the downstream logic unit must be capable of detecting failure currents of the upper level for signal on alarm (≥ 21.0 mA) and the lower level for signal on alarm (≤ 3.6 mA).

5.1.5 Alarm and warning messages

Additional information is provided by the alarm and warning messages in the form of error codes and associated clear text messages.

The following table shows the correlation between the error code and the current output:

Error code ¹⁾	Current output (message type)	Note
Fxxx	≥ 21.0 mA or ≤ 3.6 mA	xxx = three-digit number
Mxxx	corresponding to measuring mode	xxx = three-digit number

Error code ¹⁾	Current output (message type)	Note
Cxxx	corresponding to measuring mode	xxx = three-digit number
Sxxx	corresponding to measuring mode	xxx = three-digit number

1) The error codes are listed in the Operating Instructions.

Exceptions:

Error code ¹⁾	Current output (message type)	Note
M272	$\geq 21.0 \text{ mA}$ or $\leq 3.6 \text{ mA}$	Main electronic failure
C484	$\geq 21.0 \text{ mA}$ or $\leq 3.6 \text{ mA}$	Simulation failure mode
S942	$\geq 21.0 \text{ mA}$ or $\leq 3.6 \text{ mA}$	In safety distance

1) The error codes are listed in the Operating Instructions.

 When SIL locking is active on the device, additional diagnostics are activated (e.g. a comparison between the readback-current with the nominal value). If one of these diagnostics results in an error message (e.g. F803 loop current) and the SIL locking is then deactivated, the error message remains while the error persists, even if the diagnostic is no longer active in the unlock state. In this case, the device must be disconnected briefly from the power supply (e.g. by unplugging the terminals). When the device is then restarted, a self-check is carried out, and the error message is reset where applicable.

5.2 Parameter configuration for safety-related applications

5.2.1 Calibration of the measuring point

The adjustment of the measuring point is described in the Operating Instructions →  8.

Check the initial factory setting of the E (zero point) and F (range) parameters in accordance with the desired measuring range and correct if necessary.

5.2.2 Methods of device configuration

When using the devices in process control safety systems, the device configuration must comply with two requirements:

- Confirmation concept:
Proven, independent testing of safety-related parameters entered.
- Locking concept:
Locking of the device following parameter configuration (as per IEC 61511-1 : 2016 Section 11.6.3).

To activate the SIL mode, the device must run through an operating sequence, during which the device can be operated by means of the device display or any asset management tool (FieldCare, Pactware, AMS, PDM, Field Communicator 375/475, ...) for which integration is available.

Two methods of configuring the device are provided, which differ mainly with regard to the confirmation concept:

- "Increased safety mode"

While running through the commissioning sequence here, critical parameters which control functions in the safety path are either set automatically by the device to safe values or transferred to the display/operating tool via an alternative data format, to enable checking of the setting.

This mode can be used for standard applications. As there are only a few safety-related parameters which can be freely configured, the risk of operating errors is greatly reduced, and the level in the tank does not need to be changed during commissioning in order to check the settings.

- "Expert mode"

A larger number of safety-related parameters can be freely configured here. This means that the device can be adapted to difficult applications. However, the settings must be checked by directly approaching the level in the tank or a similar method.





A mechanical swivel reflector can be used for example as a method for checking in the case of MAX monitoring. If a swivel reflector is used, the device must be operated with the "Very fast" setting in the operating menu under "Setup > Advanced setup > Level > Max. filling speed liquid".

A detailed description of both modes is provided in the following sections.

 It is only in the case of SIL devices (ordering feature 590 "Additional Approval", option LA "SIL") that the SIL commissioning sequence is visible on the display and in external operating tools. For this reason, SIL locking can only be activated on these devices.

Locking in "Increased safety mode"

To commission the device, carry out and document the following steps in the order shown →  35.

1. Reset device. This resets all parameters to defined values. To do this, select: "Diagnostics > Device reset > To factory defaults" or "Diagnostics > Device reset > To delivery settings"
2. Carry out configuration. The configuration procedure and the meaning of the individual parameters are described in the Operating Instructions →  8. Observe the following parameter settings →  18.
3. Carry out "Device check". Activate the "Diagnostics > Device check > Start device check" parameter (more information available in the Operating Instructions →  8). The signal quality is tested here and possible installation errors are detected.
4. Start SIL/WHG confirmation sequence. To do this, enter the appropriate locking code (WHG: 7450; SIL: 7452; SIL and WHG: 7454) in the "Setup > Advanced setup > SIL/WHG confirmation > Set write prot." parameter.
 -  In this way, forbidden parameter changes (e.g. via external operating tools if the confirmation sequence is performed at the device display) are prevented already during the SIL/WHG confirmation sequence.
5. For "Commissioning" select the "Increased safety" entry from the list. The device checks the parameter settings in accordance with the table and forces the switching of parameters if necessary. Once testing is complete, "SIL/WHG prepar.: Finished" is displayed, and the commissioning sequence can continue.
 -  ■ If configuration was not performed in accordance with the specifications in point 2, only "Expert mode" can be selected at this point.
 - The commissioning mode must not be changed during completion of the SIL confirmation sequence. If the wrong option has been selected, the sequence must be canceled and started again.

6. Simulate the distance values using the "Value sim. dist." parameter checking that the current output responds as it should. For MIN monitoring and MAX monitoring, in each case simulate a distance directly above and below the switch point. For range monitoring, 5 distance values should be simulated which cover the entire measuring range.



⚠ CAUTION

During distance simulation, the loop current does not correspond to the measured value.



- ▶ It must be ensured that there is no risk of danger arising from this.
7. Confirm that the distance simulation is correct. To do so, select the "Yes" value for the "Sim. correct" parameter.
 8. Compare the character string which is now output ("0123456789+-,.") with the reference string printed here, and confirm if the output is correct.
 9. The parameters previously configured and which require confirmation are transferred via an independent data format to the display/operating tool. Check the parameters one after the other and confirm if correct.
 10. Enter the locking code (WHG: 7450; SIL: 7452; SIL and WHG: 7454) once again under "Set write prot.". The locking status must be checked after SIL locking: The parameter "Setup > Advanced setup > Locking status > SIL locked" must be confirmed with an "X".
 11. As an option, hardware locking can also be activated (via the dip switch marked "WP" on the main electronics).

Locking in "Expert mode"

To commission the device, carry out and document the following steps in the order shown →  35.

1. Reset device. This resets all parameters to defined values. To do this, select: "Diagnostics > Device reset > To factory defaults" or "Diagnostics > Device reset > To delivery settings"
2. Carry out configuration. The configuration procedure and the meaning of the individual parameters are described in the Operating Instructions →  8. Observe the following parameter settings →  18.
3. Carry out "Device check". Activate the "Diagnostics > Device check > Start device check" parameter (more information available in the Operating Instructions →  8). The signal quality is tested here and possible installation errors are detected.
4. Start SIL/WHG confirmation sequence. To do this, enter the appropriate locking code (WHG: 7450; SIL: 7452; SIL and WHG: 7454) in the "Setup > Advanced setup > SIL/WHG confirmation > Set write prot." parameter.
5. For "Commissioning" select the "Expert mode" entry from the list. The device checks the parameter settings in accordance with the table and forces the switching of parameters if necessary. Once testing is complete, "SIL/WHG prepar.: Finished" is displayed, and the commissioning sequence can continue.

 The commissioning mode must not be changed during completion of the SIL confirmation sequence. If the wrong option has been selected, the sequence must be canceled and started again.

6. Carry out function test. For MIN and MAX monitoring, at least one level below (MIN monitoring) or above (MAX monitoring) the switch point must be approached. For range monitoring, 5 distance values should be approached which cover the entire measuring range. Verify in each case that the response of the current output is correct.
If it is not possible to approach the required level values, a test in accordance with test sequence D (proof test →  28) can be performed prior to locking. However, this does not detect all possible errors (e.g. insufficient adjustment). For this reason, we recommend that the measured values be tested and documented in accordance with test sequence A (proof test →  24) at a time when the required point level/levels have been reached.
7. Confirm that the function test has been successful. To do so, select the "Yes" entry for "Conf. funct. test".
8. Enter the locking code (WHG: 7450; SIL: 7452; SIL and WHG: 7454) once again under "Set write prot.". The locking status must be checked after SIL locking: The parameter "Setup > Advanced setup > Locking status > SIL locked" must be confirmed with an "X".
9. As an option, hardware locking can also be activated (via the dip switch marked "WP" on the main electronics).
 For step 6: In accordance with IEC 61508-1 : 2010, Section 7.14, this test is included in the "Overall safety validation" and is the responsibility of the operator.

Further parameter settings

The following parameters affect the safety function. However, they may be freely configured in accordance with the application. In increased safety mode, it is necessary to confirm the configured values during the remainder of the commissioning process. Confirmation is not required in expert mode. It is recommended to note down the configured values!

Parameter	Parameter name
Setup	Tank type ¹⁾
	Tube diameter ^{1) 2)}
	Bin type ³⁾
	Max. filling speed solid ³⁾
	Max. draining speed solid ³⁾
	Empty calibration
	Full calibration
	Advanced setup → Level → Advanced process conditions
	Advanced setup → Level → Tank/silo height

- 1) Only for liquid measurement
- 2) Only for pipe/bypass
- 3) Only for bulk solids measurement

The following parameters affect the safety function and are not freely configurable in the increased safety mode. Instead, they are automatically changed by the device at the start of the SIL/WHG confirmation to the safety-oriented values mentioned. If these parameters are to be set to other values, expert mode must be selected.

Parameter	Preset value
Setup → Advanced setup → Level → Level correction	0
Setup → Advanced setup → Linearization → Linearization type	None
Setup → Advanced setup → Current output 1 → Assign current output	Level linearized
Setup → Advanced setup → Current output 1 → Damping output (0363-1)	0
Setup → Advanced setup → Display → Backlight	Disable
Expert → Sensor → Level → Distance offset	0
Expert → Sensor → Level → L max. drain speed	0
Expert → Sensor → Level → L max. fill speed	0
Expert → Sensor → Level → Level limit mode	Off
Expert → Sensor → Level → Output mode	Level linearized
Expert → Sensor → Safety settings → Jump delay echo lost	Off
Expert → Sensor → Safety settings → Delay time echo lost	3 s
Expert → Output → Current output 1 → Assign current output	
Expert → Output → Current output 1 → Turn down	Off
Expert → Output → Current output 1 → Measuring mode	Standard
Expert → Communication → Configuration → HART address	0

The following parameters affect the safety function and are automatically adapted by the device when configuring higher-ranking parameters (known as application parameters). This indirect setting is permitted in increased safety mode. However, it is not permitted to

change the parameters directly. If these parameters were changed directly, only expert mode is available for selection in the SIL/WHG confirmation.

Parameter	Parameter name
Setup	Advanced setup → Level → Max. draining speed liquid
	Advanced setup → Level → Max. filling speed liquid
	Advanced setup → Level → Blocking distance
Expert	Sensor → Envelope curve → Envelope curve statistic
	Sensor → Envelope curve → Envelope Curve Statistic in window down
	Sensor → Envelope curve → Envelope Curve Statistic in window up
	Sensor → Envelope curve → Envelope Curve Statistic out window down
	Sensor → Envelope curve → Envelope Curve Statistic out window up
	Sensor → Envelope curve → Envelope Curve Statistic window size
	Sensor → Envelope curve → Envelope smoothing mode
	Sensor → Envelope curve → Asymmetric envelope smoothing near down
	Sensor → Envelope curve → Asymmetric envelope smoothing near up
	Sensor → Envelope curve → Asymmetric envelope smoothing far down
	Sensor → Envelope curve → Asymmetric envelope smoothing far up
	Sensor → Envelope curve → Envelope smoothing
	Sensor → Sensor properties → HF module mode
	Sensor → Distance → Dead time
	Sensor → Distance → Integration time
	Sensor → Distance → Max. integration time
	Sensor → Distance → Delta at integration time
	Sensor → Safety settings → Echo lost window right
	Sensor → Safety settings → Echo lost window left
	Sensor → Safety settings → Draining filter
	Sensor → Safety settings → Filling filter
	Sensor → Weighting curves → Weighting curve selection
	Sensor → Weighting curves → FAC window size
	Sensor → Weighting curves → FAC offset
	Sensor → Weighting curves → FMC window size
	Sensor → Weighting curves → FMC offset
	Sensor → Weighting curves → IEC offset
	Sensor → Mapping → Map offset
	Sensor → Mapping → Mapping window size
	Sensor → First echo factor → First echo mode
	Sensor → First echo factor → First echo factor
	Sensor → Echo fine adjustment → Fine adjustment mode
	Sensor → Echo fine adjustment → Parabolic fit window size
	Sensor → Echo fine adjustment → Merge echo distance
	Sensor → Echo fine adjustment → Merging echo window
	Sensor → Echo fine adjustment → Merging ratio
Sensor → Tank bottom evaluation → Tank bottom range	

Parameter	Parameter name
	Sensor → Tank bottom evaluation → Min. amplitude TBD
	Sensor → Tank bottom evaluation → Lower level area
	Sensor → Echo tracking → Evaluation mode
	Sensor → Echo tracking → Window size tracking
	Sensor → Echo tracking → Maximal track counter

The following parameters affect the safety function and cannot be freely configured in increased safety mode or in expert mode. Instead they are automatically changed by the device at the start of the SIL/WHG confirmation to the safety-oriented values mentioned.

Parameter	Preset value
Setup → Advanced setup → Safety settings → Output echo lost	Alarm
Diagnostics → Simulation → Assign measurement variable	Off
Diagnostics → Simulation → Current output 1 simulation	Off
Diagnostics → Simulation → Device alarm simulation	Off
Diagnostics → Simulation → Diagnostic event simulation	65533
Expert → Sensor → Distance → Hysteresis	0
Expert → Sensor → Distance → Velocity filter	Off
Expert → Output → Current output 1 → Trim	

The following parameters affect the safety function. If the settings differ from the as-delivered state of the device, only the expert mode is available for selection in the SIL/WHG confirmation.

Parameter	Parameter name
Setup	Advanced setup → Level → Medium type
	Advanced setup → Level → Blocking distance
	Advanced setup → Current output 1 → Current span
Expert	Sensor → Envelope curve → Envelope curve statistic
	Sensor → Envelope curve → Asymmetric envelope smoothing near dist.
	Sensor → Sensor properties → Sensor type
	Sensor → Sensor properties → Antenna ext.len.
	Sensor → Sensor properties → Antenna ext. diameter
	Sensor → Sensor properties → Microfactor
	Sensor → Sensor properties → Antenna zero distance
	Sensor → Sensor properties → Cable zero distance
	Sensor → Sensor properties → Inactive length
	Sensor → Distance → Blocking distance evaluation mode
	Sensor → Gas phase compensation → GPC mode
	Sensor → Gas phase compensation → Gas phase compensation factor
	Sensor → Gas phase compensation → Reference distance
	Sensor → Gas phase compensation → Reference echo window
	Sensor → Gas phase compensation → Reference echo threshold
Sensor → Gas phase compensation → Const. GPC factor	



Parameter	Parameter name
	Sensor → Weighting curves → Max Value EWC
	Sensor → Mapping → Map gap
	Sensor → Mapping → Map gap
	Sensor → First echo factor → Fix factor EWC
	Sensor → First echo factor → First echo factor threshold
	Sensor → Echo fine adjustment → Merge echo distance
	Sensor → Echo fine adjustment → Merging echo window
	Sensor → Echo fine adjustment → Merging ratio
	Sensor → Echo fine adjustment → Edge correction

The following parameters affect the safety function. If the settings differ from the permitted values mentioned, the SIL/WHG confirmation is canceled automatically, and the device cannot be locked neither in increased safety mode nor in expert mode.

Parameter	Preset value
Setup → Advanced setup → Current output 1 → Assign current output	
Setup → Advanced setup → Current output 1 → Failure mode	Min. or Max.
Expert → Output → Current output 1 → Assign current output	
Expert → Output → Current output 1 → Start-up mode	Min. or Max.
Expert → Communication → Output → Assign PV	

-  Those parameters which are not mentioned do not affect the safety function and can be configured to any meaningful values. The visibility of the parameters mentioned in the operating menu depends in part on the user role, the SW options ordered and on the configuration of other parameters.
- In the SIL mode, the device must not be operated in HART-Multidrop mode, as otherwise the current output will assume a fixed value. For this reason, only the setting "Expert > Communication > HART address = 0" is permitted in the SIL mode and in the combined SIL/WHG mode when in the increased safety mode. In pure WHG mode, HART Multidrop is permitted in the expert mode as long as the HART signal is evaluated in an external switching unit (e.g. Tank Side Monitor NRF590) that complies with the approval principles as per WHG.

Unlocking a SIL-device

When SIL locking is active on a device, the device is protected against unauthorized operation by means of a locking code and, as an additional option, by means of a hardware write protection switch. The device must be unlocked in order to change the configuration, to perform proof tests as per test sequence B →  25, test sequence C →  26 or test sequence D →  28, as well as to reset self-holding diagnostic messages.

 CAUTION

Unlocking the device deactivates diagnostic functions, and the device may not be able to carry out its safety function when unlocked.

- ▶ Therefore, independent measures must be taken to ensure that there is no risk of danger while the device is unlocked.

To unlock, proceed as follows:

1. Check the position of the hardware write protection switch (dip switch marked "WP" on main electronics), and set this switch to "Off".

2. Select "Setup > Advanced setup > Deactiv. SIL/WHG" and enter the appropriate unlocking code (WHG: 7450; SIL: 7452; SIL and WHG: 7454) for the "Res. write prot." parameter.
 - ↳ The "End of sequence" message indicates that the device was successfully unlocked.

5.3 Proof-testing

Check the operativeness and safety of safety functions at appropriate intervals! The operator must determine the time intervals.

The values and graphics in the "Additional safety-related characteristics" section can be used for this purpose →  5. The test must be carried out in such a way that it verifies the correct operation of the protective system in interaction with all of the components.

 In a single-channel architecture, the PFD_{avg} value to be used depends on the diagnostic rate of coverage for the proof-test (PTC = Proof Test Coverage) and the intended lifetime (LT = Lifetime), as specified in the following formula:

$$PFD_{avg} = \frac{1}{2} \cdot PTC \cdot \lambda_{DU} \cdot T_1 + \lambda_{DD} \cdot MTTR + \frac{1}{2} \cdot (1 - PTC) \cdot \lambda_{DU} \cdot LT$$

A0024244

For the proof-tests described as follows, the respective proof test coverages are specified, which may be used for calculation.

Proof-testing of the device can be performed as follows:

1. Approaching the level in the original tank (→ test sequence A).
2. Remove the device and test using a test vessel (→ test sequence B).
3. Device self-test and level simulation (→ test sequence C). No change of level in the tank is necessary for this sequence.
4. Device self-test and level simulation. No change of level in the tank is necessary for this sequence. Additional check of the measurement at an arbitrary level within the measuring range (→ test sequence D). This achieves a higher diagnostic rate of coverage than with test sequence C without changing the level.

You must also check that all cover seals and cable entries are sealing correctly.

CAUTION

To ensure process safety.

- ▶ During the proof-test, alternative monitoring measures must be taken to ensure process safety.

 If one of the test criteria from the following test sequences is not fulfilled, the device may no longer be used as part of a protective system. The purpose of proof-testing is to detect random device failures (λ_{du}). The impact of systematic faults on the safety function is not covered by this test and must be assessed separately. Systematic faults can be caused, for example, by process material properties, operating conditions, build-up or corrosion.

5.3.1 Test sequence A



Preparation

1. Connect suitable measuring device (recommended accuracy better than ± 0.1 mA) to the current output.
2. Determine the safety setting (level limit or range monitoring).

Procedure for level limit monitoring

1. Check safety function: Approach one level immediately above (MAX monitoring) or below (MIN monitoring) the limit to be monitored. A mechanical swivel reflector can be used for example as a method for checking in the case of MAX monitoring. If a swivel reflector is used, the device must be put into operation for the first time with the "Very fast > 2m (80in) /min" setting in the operating menu under "Setup > Advanced setup > Level > Max. filling speed liquid".
2. Check safety function: Read the output current, record it and assess for accuracy.
3. If (as an option) the function of the measuring point is to be checked immediately in front of the switch point: Checks the function in front of MIN or MAX switch point: Approach level immediately below (MAX monitoring) or above (MIN monitoring) the limit to be monitored. Read the output current, record it and assess for accuracy. This does not check the safety function of the device.
4. The test is to be considered successful if the current values trigger or ensure the required function.

Procedure for range monitoring

1. Approach five levels within the range to be monitored.
 2. Read the output current at each level value, record it and assess for accuracy.
 3. The test is to be considered successful if the current values in step 2 are within the required level of accuracy.
-  The proof-test is to be considered to have failed if the expected current value deviates for a specific level by $> \pm 2$ %. For troubleshooting, refer to the Operating Instructions →  8. 99 % of dangerous, undetected failures are detected using this test (Proof test coverage, PTC = 0.99).

5.3.2 Test sequence B

Preparation

1. It is recommended to perform the test using the medium to be measured or using a medium with comparable properties, e.g. comparable dielectric constant. To do so, prepare a test vessel (may be open or closed). For installation instructions, refer to the Operating Instructions →  8. If this is not possible, the function can also be checked using another medium (e.g. water) or using a mechanical swivel reflector.
2. Deactivate SIL mode. To do so, enter the appropriate unlocking code (WHG: 7450; SIL: 7452; SIL and WHG: 7454) in the "Setup > Advanced setup > Deactiv. SIL/WHG" operating menu.
3. Remove the device and mount it in a closed test tank or above an open test tank.
4. Connect suitable measuring device (recommended accuracy better than ± 0.1 mA) to the current output.
5. Perform interference echo mapping if the shape and size of the test tank is different.
6. Determine the safety setting (level limit or range monitoring).

Procedure for level limit monitoring

1. Approach a level directly below (MAX monitoring) or directly above (MIN monitoring) the level limit to be monitored.
2. Read the output current, record it and assess for accuracy.
3. Approach the level directly above (MAX monitoring) or directly below (MIN monitoring) the level limit to be monitored.
4. Read the output current, record it and assess for accuracy.
5. The test is to be considered successful if the current in step 2 does not result in activation of the safety function but the current in step 4 does.

Procedure for range monitoring

1. Approach five levels within the range to be monitored.
2. Read the output current at each level value, record it and assess for accuracy.
3. The test is to be considered successful if the current values in step 2 are within the required level of accuracy.



The proof-test is to be considered to have failed if the expected current value deviates for a specific level by $> \pm 2$ %. For troubleshooting, refer to the Operating Instructions →  8. 99 % of dangerous, undetected failures are detected using this test (Proof test coverage, PTC = 0.99).

CAUTION

Re-installation in the original tank

SIL mode is not activated.

- ▶ SIL mode must be reactivated →  14.
- ▶ If an interference echo mapping was performed in the test tank, it is necessary following installation in the original tank to carry out another interference echo mapping that is valid for that tank.

5.3.3 Test sequence C

Preparation

1. Deactivate SIL mode. (WHG: 7450; SIL: 7452; SIL and WHG: 7454) in the "Setup > Advanced setup > Deactiv. SIL/WHG" operating menu.
2. Connect suitable measuring device (recommended accuracy better than ± 0.1 mA) to the current output.
3. Determine the safety setting (level limit or range monitoring).

Procedure for level limit monitoring

1. Perform device self-check. To do so, select the value "Yes" in the "Expert > Sensor > Sensor diag. > Start self check" list. After performing the test, read the test results in the "Expert > Sensor > Sensor diag. > Result self check" parameter. This part of the test has been passed only when "OK" is displayed here.
2. Simulate a level directly below (MAX monitoring) or directly above (MIN monitoring) the level limit to be monitored. To do so, select the value "Level" in the operating menu in the "Diagnostics > Simulation > Assign meas. var." list and enter the value in the "Diagnostics > Simulation > Process variable value" parameter.
3. Read the output current, record it and assess for accuracy.
4. Simulate a level directly above (MAX monitoring) or directly below (MIN monitoring) the level limit to be monitored.
5. Read the output current, record it and assess for accuracy.
6. The test is to be considered successful if the current in step 2 does not result in activation of the safety function but the current in step 4 does.

 When selecting the "Expert" menu group, a prompt for the access code appears on the display. If an access code was defined under "Setup > Advanced setup > Def. access code" this must be entered here. If no access code was defined, the prompt can be acknowledged by pressing the "E" key.

Procedure for range monitoring

1. Perform device self-check. To do so, select the value "Yes" in the "Expert > Sensor > Sensor diag. > Start self check" list. After performing the test, read the test results in the "Expert > Sensor > Sensor diag. > Result self check" parameter. This part of the test has been passed only when "OK" is displayed here.
2. Simulate five levels within the range to be monitored. Procedure, → Limit value monitoring, step 2.
3. Read the output current at each level value, record it and assess for accuracy.
4. The test is to be considered successful if the current values in step 2 are within the required level of accuracy.

 When selecting the "Expert" menu group, a prompt for the access code appears on the display. If an access code was defined under "Setup > Advanced setup > Def. access code" this must be entered here. If no access code was defined, the prompt can be acknowledged by pressing the "E" key.

- The proof-test is to be considered to have failed if the expected current value deviates for a specific level by $> \pm 2$ %. For troubleshooting, refer to the Operating Instructions →  8. 56 % of dangerous, undetected failures are detected using this test (Proof test coverage, PTC = 0.56).
A number of sensor (antenna) faults and faults in the sensor electronics are not detected.

⚠ CAUTION

Once test sequence C has been completed, the SIL mode is no longer activated.

- ▶ The SIL mode must be activated again in accordance with "Device parameter configuration for safety-related applications" → 14
- ▶ The following steps do not need to be performed again in this case: Steps 1 and 2 were performed in the context of (initial) commissioning/configuration. Steps 3 and 6 were performed in the context of this proof test with the relevant diagnostic coverage.

5.3.4 Test sequence D

Preparation

1. Deactivate SIL mode. (WHG: 7450; SIL: 7452; SIL and WHG: 7454) in the "Setup > Advanced setup > Deactiv. SIL/WHG" operating menu.
2. Connect suitable measuring device (recommended accuracy better than ± 0.1 mA) to the current output.
3. Determine the safety setting (level limit or range monitoring).

Procedure for level limit monitoring



1. Perform device self-check. To do so, select the value "Yes" in the "Expert > Sensor > Sensor diag. > Start self check" list. After performing the test, read the test results in the "Expert > Sensor > Sensor diag. > Result self check" parameter. This part of the test has been passed only when "OK" is displayed here.
2. Read the actual measured value displayed by the device at an arbitrary level within the measuring range or determine the actual output current and compare it with the set point defined by the current level. This part of the test is deemed successful if the values are within the required level of accuracy.
3. Simulate a level directly below (MAX monitoring) or directly above (MIN monitoring) the level limit to be monitored. To do so, select the value "Level" in the operating menu in the "Diagnostics > Simulation > Assign meas. var." list and enter the value in the "Diagnostics > Simulation > Process variable value" parameter.
4. Read the output current, record it and assess for accuracy.
5. Simulate a level directly above (MAX monitoring) or directly below (MIN monitoring) the level limit to be monitored.
6. Read the output current, record it and assess for accuracy.
7. The test is to be considered successful if the current in step 2 does not result in activation of the safety function but the current in step 4 does.



When selecting the "Expert" menu group, a prompt for the access code appears on the display. If an access code was defined under "Setup > Advanced setup > Def. access code" this must be entered here. If no access code was defined, the prompt can be acknowledged by pressing the "E" key.

Procedure for range monitoring

1. Perform device self-check. To do so, select the value "Yes" in the "Expert > Sensor > Sensor diag. > Start self check" list. After performing the test, read the test results in the "Expert > Sensor > Sensor diag. > Result self check" parameter. This part of the test has been passed only when "OK" is displayed here.
2. Read the actual measured value displayed by the device at an arbitrary level within the measuring range or determine the actual output current and compare it with the set point defined by the current level. This part of the test is deemed successful if the values are within the required level of accuracy.
3. Simulate five levels within the range to be monitored. Procedure, → Limit value monitoring, step 2.
4. Read the output current at each level value, record it and assess for accuracy.

5. The test is to be considered successful if the current values in step 2 are within the required level of accuracy.
 -  When selecting the "Expert" menu group, a prompt for the access code appears on the display. If an access code was defined under "Setup > Advanced setup > Def. access code" this must be entered here. If no access code was defined, the prompt can be acknowledged by pressing the "E" key.
 - When selecting the "Expert" menu group, a prompt for the access code appears on the display. If an access code was defined under "Setup > Advanced setup > Def. access code" this must be entered here. If no access code was defined, the prompt can be acknowledged by pressing the "E" key.
 - The proof-test is to be considered to have failed if the expected current value deviates for a specific level by $> \pm 2\%$. For troubleshooting, refer to the Operating Instructions →  8. 93 % of dangerous, undetected failures are detected using this test (Proof test coverage, PTC = 0.93).

 CAUTION

Once test sequence D has been completed, the SIL mode is no longer activated.

- ▶ The SIL mode must be activated again in accordance with "Device parameter configuration for safety-related applications" →  14
- ▶ The following steps do not need to be performed again in this case: Steps 1 and 2 were performed in the context of (initial) commissioning/configuration. Steps 3 and 6 were performed in the context of this proof test with the relevant diagnostic coverage.

6 Life cycle

6.1 Requirements for personnel

The personnel for installation, commissioning, diagnostics, repair and maintenance must meet the following requirements:

- Trained, qualified specialists must have a relevant qualification for this specific function and task
- Are authorized by the plant owner/operator
- Are familiar with federal/national regulations
- Before beginning work, the specialist staff must have read and understood the instructions in the manuals and supplementary documentation as well as in the certificates (depending on the application)
- Follow instructions and comply with basic conditions

The operating personnel must meet the following requirements:

- Are instructed and authorized according to the requirements of the task by the facility's owner-operator
- Follow the instructions in this manual

6.2 Installation

The installation of the device is described in the relevant Operating Instructions →  8.

6.3 Commissioning

The commissioning of the device is described in the relevant Operating Instructions →  8.

6.4 Operation

The operation of the device is described in the relevant Operating Instructions →  8.

6.5 Maintenance

Please refer to the relevant Operating Instructions for information on maintenance and recalibration →  8.

 Alternative monitoring measures must be taken to ensure process safety during configuration, proof-testing and maintenance work on the device.

6.6 Repairs



Repair means restoring functional integrity by replacing defective components. Components of the same type must be used for this purpose. We recommend documenting the repair. This includes specifying the device serial number, the repair date, the type of repair and the individual who performed the repair.

The following components may be replaced by the customer's technical staff if genuine spare parts are used and the appropriate installation instructions are followed:

Component	Installation Instructions	Checking the device after repair
Antennas	EA01069F/00 (FMR51) EA01071F/00 (FMR50, FMR52, FMR53, FMR56)	<ul style="list-style-type: none"> ▪ Visual inspection to check whether all parts are present and properly mounted ▪ Interference echo mapping must be recorded again ▪ Proof check; test sequence A or B
Antenna horns	EA01070F/00 (FMR54) EA01068F/00 (FMR57)	<ul style="list-style-type: none"> ▪ Visual inspection to check whether all parts are present and properly mounted ▪ Check the measurement at an arbitrary level
Slip-on flange	EA01103F/00 (FMR50, FMR56)	<ul style="list-style-type: none"> ▪ Visual inspection to check whether all parts are present and properly mounted ▪ Proof check; test sequence A or B
HF cable	EA01067F/00	<ul style="list-style-type: none"> ▪ Visual inspection to check whether all parts are present and properly mounted ▪ Interference echo mapping must be recorded again ▪ Proof check; test sequence A or B
Seal between antenna and housing	EA00036F/00	<ul style="list-style-type: none"> ▪ Visual inspection to check whether all parts are present and properly mounted ▪ Proof check; test sequence A or B
Display SD02/SD03	EA00102D/06	Visual inspection to check whether all parts are present and properly mounted
Transmitter electronics of the remote display FHX50	EA01064F/00	Visual inspection to check whether all parts are present and properly mounted
Cable of the remote display FHX50	General safety data sheet: EA01062F/00	Visual inspection to check whether all parts are present and properly mounted
Main electronics	EA00041F/00	<ul style="list-style-type: none"> ▪ Visual inspection to check whether all parts are present and properly mounted ▪ Interference echo mapping must be recorded again ▪ Proof check; test sequence A or B
I/O-Module	EA00039F/00	<ul style="list-style-type: none"> ▪ Visual inspection to check whether all parts are present and properly mounted ▪ Check the measurement at an arbitrary level
Overvoltage protection OVP10/20	SD01090F/00	<ul style="list-style-type: none"> ▪ Visual inspection to check whether all parts are present and properly mounted ▪ Check the measurement at an arbitrary level
Terminals for I/O modules	EA00040F/00	<ul style="list-style-type: none"> ▪ Visual inspection to check whether all parts are present and properly mounted ▪ Check the measurement at an arbitrary level
Housing cover	EA00035F/00	Visual inspection to check whether all parts are present and properly mounted
Housing cover seals	EA00036F/00	Visual inspection to check whether all parts are present and properly mounted

Component	Installation Instructions	Checking the device after repair
Housing filters (vent plugs)	EA00037F/00	Visual inspection to check whether all parts are present and properly mounted
Safety clamps, housing	EA00038F/00	Visual inspection to check whether all parts are present and properly mounted

Installation Instructions, see the Download Area at www.endress.com.

The replaced component must be sent to Endress+Hauser for the purpose of fault analysis if the device has been operated in a protective system and a device error cannot be ruled out. In this case, always enclose the "Declaration of Hazardous Material and Decontamination" with the note "Used as SIL device in protection system" when returning the defective device. In this case, please refer to the "Return" section of the Operating Instructions.

6.7 Modification

 Modifications are changes to SIL capable devices already delivered or installed.

Modifications to SIL capable devices are usually performed in the Endress+Hauser manufacturing center.

Modifications to SIL capable devices onsite at the user's plant are possible following approval by the Endress+Hauser manufacturing center. In this case, the modifications must be performed and documented by an Endress+Hauser service technician.

Modifications to SIL capable devices by the user are not permitted.

7 Appendix

7.1 Structure of the measuring system

7.1.1 System components

The measuring system's devices are displayed in the following diagram (example):

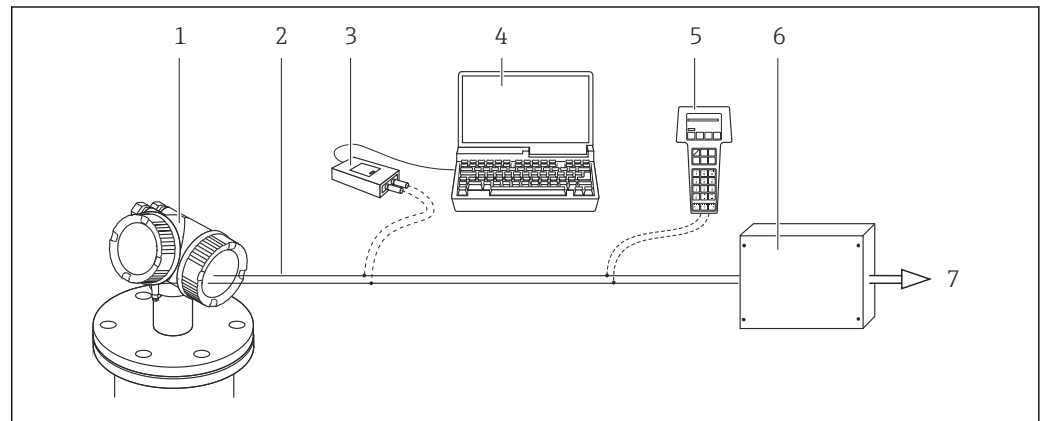

- 1 Micropilot (optional with display module SD02/SD03)
- 2 4 to 20 mA line
- 3 Commubox FXA191/195
- 4 Computer with operating tool, e.g. FieldCare
- 5 Field Communicator 375/475
- 6 Logic Unit, e.g. PLC, limit signal transmitter
- 7 Actuator

An analog signal (4 to 20 mA) in proportion to the level is generated in the transmitter. This is sent to a downstream logic unit (e.g. PLC, limit signal transmitter, ...) where it is monitored to determine whether it is below or above a specified limit value.

For fault monitoring, the logic unit must recognize both HI-alarms (≥ 21.0 mA) and LO-alarms (≤ 3.6 mA).

7.1.2 Description of use as a protective system

The Micropilot is a "downward-looking" measuring system, operating based on the time-of-flight method (ToF). The distance from the reference point (process connection of the measuring device) to the product surface is measured. High-frequency pulses are emitted via an antenna. The pulses are reflected by the product surface, received by the electronic evaluation unit and converted into level information. This method is also known as level-radar.

Typical measuring arrangement:

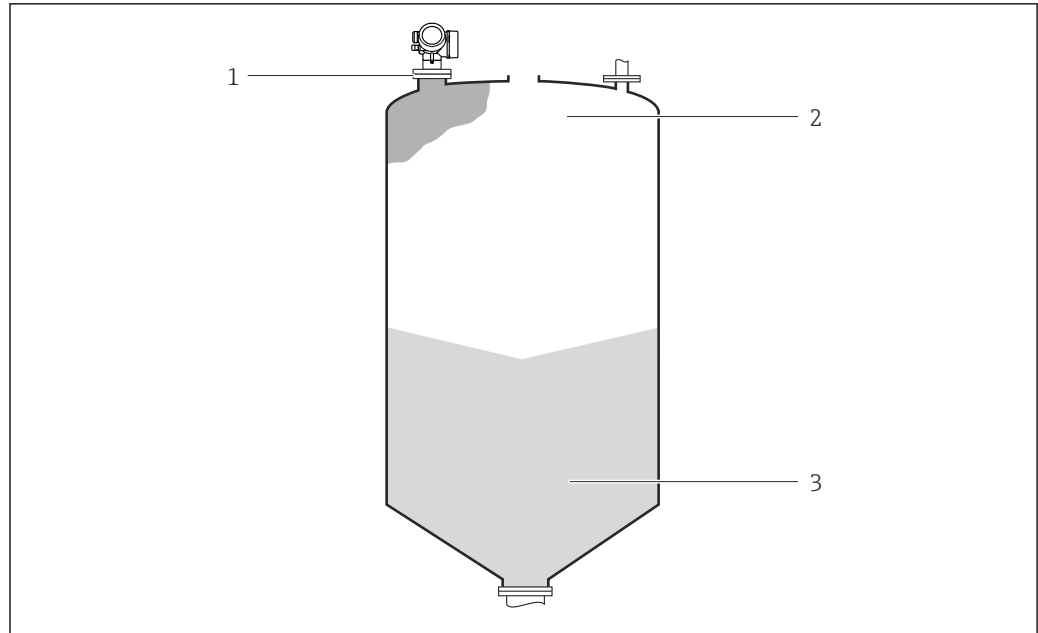

A0024238

- 1 Flange: Reference point of measurement
- 2 20 mA, 100%
- 3 4 mA, 0%

The device can be used in this arrangement in safety instrumented systems for MIN safety, MAX safety and range monitoring.

 Correct installation is a prerequisite for safe operation of the device.

7.2 Proof-testing

System-specific data		
Company		
Measuring point/TAG no.		
Facility		
Device type/Order code		
Serial number of device		
Name		
Date		
Access code (if individual to each device)		
Locking code used	WHG <input type="checkbox"/> 7450 SIL <input type="checkbox"/> 7452 SIL and WHG <input type="checkbox"/> 7454	
Signature		

Device-specific commissioning parameters (only in "Increased safety mode")	
Tank type (liquid measurement)	
Tube diameter (liquid measurement; pipe/bypass)	
Bin type (bulk solids)	
Max. filling speed (bulk solids measurement)	
Max. draining speed (bulk solids measurement)	
Empty calib.	
Full calibration	
Advanced process conditions	
Tank/silo height	

Proof-test protocol		
Test step	Set point	Actual value
1. Current value 1		
2. Current value 2		
3. Current value 3 (if necessary)		
4. Current value 4 (if necessary)		
5. Current value 5 (if necessary)		

7.3 Notes on the redundant use of multiple sensors

This section provides additional information regarding the use of homogeneous redundancy sensors e.g. 1oo2 or 2oo3 architectures.

The common cause factors β and β_D indicated in the table below are minimum values for the Micropilot. These must be used when designing the sensor subsystem.

Minimum value β with homogeneous redundant use	2 %
Minimum value β_D with homogeneous redundant use	1 %

The device meets the requirements for SIL 3 in homogeneous redundancy.

The following must be taken into account in proof-testing:

If an error is detected in one of the redundantly operated devices, the other devices must be checked to see if there is the same error.

7.4 Further information



General information on functional safety (SIL) is available at:

www.de.endress.com/SIL (Germany) or www.endress.com/SIL (English) and in the Competence Brochure CP01008Z/11 "Functional Safety in the Process Industry- Risk Reduction with Safety Instrumented Systems".



71758167

www.addresses.endress.com
