

# Operating Instructions

## Ecograph T RSG35

### Datenmanager



## Table of contents

<b>1</b>	<b>About this document</b> . . . . .	<b>5</b>		
1.1	Document function . . . . .	5		
1.2	Symbols . . . . .	5		
1.2.1	Safety symbols . . . . .	5		
1.2.2	Electrical symbols . . . . .	5		
1.2.3	Symbols for certain types of information . . . . .	5		
1.2.4	Symbols in graphics . . . . .	6		
1.3	Documentation . . . . .	6		
1.4	Change history . . . . .	7		
1.5	Registered trademarks . . . . .	7		
<b>2</b>	<b>Basic safety instructions</b> . . . . .	<b>8</b>		
2.1	Requirements for the personnel . . . . .	8		
2.2	Intended use . . . . .	8		
2.2.1	Product liability . . . . .	8		
2.3	Workplace safety . . . . .	8		
2.4	Operational safety . . . . .	8		
2.5	Product safety . . . . .	9		
2.6	Safety information for desktop version (option) . . . . .	9		
2.7	IT security . . . . .	9		
<b>3</b>	<b>Product description</b> . . . . .	<b>9</b>		
3.1	Product design . . . . .	9		
<b>4</b>	<b>Incoming acceptance and product identification</b> . . . . .	<b>10</b>		
4.1	Incoming acceptance . . . . .	10		
4.1.1	Scope of delivery . . . . .	10		
4.1.2	Product identification . . . . .	10		
4.2	Storage and transport . . . . .	11		
<b>5</b>	<b>Installation</b> . . . . .	<b>11</b>		
5.1	Installation requirements . . . . .	11		
5.1.1	Installation dimensions . . . . .	11		
5.2	Installing the measuring instrument . . . . .	12		
5.3	Post-installation check . . . . .	12		
<b>6</b>	<b>Electrical connection</b> . . . . .	<b>13</b>		
6.1	Connecting requirements . . . . .	13		
6.2	Special connection instructions . . . . .	13		
6.2.1	Cable specifications . . . . .	13		
6.3	Connecting the device . . . . .	14		
6.3.1	Terminal assignment on the rear of the device . . . . .	14		
6.3.2	Supply voltage . . . . .	15		
6.3.3	Relays . . . . .	15		
6.3.4	Digital inputs, auxiliary voltage output . . . . .	15		
6.3.5	Analog inputs . . . . .	16		
6.3.6	Connection example: Auxiliary voltage output as transmitter power supply for 2-wire sensors . . . . .	17		
6.3.7	Connection example: Auxiliary voltage output as transmitter power supply for 4-wire sensors . . . . .	18		
6.3.8	Option: RS232/RS485 interface (rear of device) . . . . .	18		
6.3.9	Ethernet connection (rear of device) . . . . .	19		
6.3.10	Option: Ethernet Modbus TCP slave . . . . .	20		
6.3.11	Option: Modbus RTU slave . . . . .	20		
6.3.12	Connections at front of device . . . . .	20		
6.4	Post-connection check . . . . .	21		
<b>7</b>	<b>Operating options</b> . . . . .	<b>22</b>		
7.1	Overview of operating options . . . . .	22		
7.2	Structure and function of the operating menu . . . . .	22		
7.2.1	Operating menu for operators and maintenance personnel . . . . .	23		
7.2.2	Operating menu for experts . . . . .	24		
7.2.3	Submenus and users . . . . .	24		
7.3	Measured value display and operating elements . . . . .	26		
7.4	Display representation of symbols used in operation . . . . .	27		
7.4.1	Symbols in operating menus . . . . .	28		
7.4.2	Symbols in the event logbook . . . . .	28		
7.5	Entering text and numbers (virtual keyboard) . . . . .	28		
7.6	Channel color assignment . . . . .	29		
7.7	Access to operating menu via local display . . . . .	29		
7.8	Device access via operating tools . . . . .	29		
7.8.1	Field Data Manager (FDM) analysis software (SQL database support) . . . . .	29		
7.8.2	Web server . . . . .	30		
7.8.3	OPC server (optional) . . . . .	30		
7.8.4	FieldCare/DeviceCare configuration software . . . . .	30		
<b>8</b>	<b>System integration</b> . . . . .	<b>31</b>		
8.1	Integrating the measuring instrument into the system . . . . .	31		
8.1.1	General information . . . . .	31		
8.1.2	Ethernet . . . . .	31		
8.1.3	Web server with "Ethernet over USB" function . . . . .	31		
8.1.4	Modbus RTU/TCP slave . . . . .	33		
<b>9</b>	<b>Commissioning</b> . . . . .	<b>33</b>		
9.1	Function check . . . . .	33		
9.2	Switching on the measuring instrument . . . . .	33		
9.3	Configuring the operating language . . . . .	34		

9.4	Configuring the measuring instrument (Setup menu) . . . . .	34	10.16	Data analysis and visualization with the Field Data Manager software (FDM) . . . . .	55
9.4.1	Step-by-step: to the first measured value . . . . .	34	10.16.1	Structure/layout of a CSV file . . . . .	55
9.4.2	Step-by-step: setting or deleting the limit values . . . . .	35	10.16.2	Importing UTF-8-encoded CSV files into spreadsheets . . . . .	56
9.4.3	Device setup . . . . .	35	<b>11</b>	<b>Diagnostics and troubleshooting . . . . .</b>	<b>56</b>
9.4.4	Setup via SD card or USB stick . . . . .	36	11.1	General troubleshooting . . . . .	57
9.4.5	Setup via web server . . . . .	36	11.2	Troubleshooting . . . . .	57
9.4.6	Setup via FieldCare/DeviceCare configuration software . . . . .	37	11.2.1	Device error/alarm relay . . . . .	57
9.5	Advanced settings (Expert menu) . . . . .	37	11.3	Diagnostic information on the local display . . . . .	57
9.6	Configuration management . . . . .	38	11.4	Pending, current diagnostic messages . . . . .	62
9.7	Simulation . . . . .	38	11.5	Diagnostic list . . . . .	62
9.8	Access protection and security concept . . . . .	38	11.6	Event logbook . . . . .	62
9.9	HTTPS web server setup . . . . .	39	11.7	Device information . . . . .	62
<b>10</b>	<b>Operation . . . . .</b>	<b>41</b>	11.8	Diagnostics of measured values . . . . .	62
10.1	Displaying and modifying current Ethernet settings . . . . .	41	11.9	Diagnostics of outputs . . . . .	62
10.2	Reading off the device locking status . . . . .	41	11.10	Simulation . . . . .	63
10.3	Reading off measured values (display devices) . . . . .	42	11.10.1	E-mail test . . . . .	63
10.4	Web server . . . . .	42	11.10.2	Testing the WebDAV client . . . . .	63
10.4.1	Access to the web server via HTTP (HTML) . . . . .	43	11.10.3	Testing time synchronization/SNTP . . . . .	63
10.4.2	Access to the web server via XML . . . . .	43	11.10.4	Relay test . . . . .	63
10.4.3	Setup, operation and service via the web server . . . . .	44	11.11	Initializing the modem . . . . .	63
10.4.4	Remote control via the web server . . . . .	48	11.12	Resetting the measuring instrument . . . . .	63
10.5	Changing group . . . . .	48	11.13	Clear memory . . . . .	64
10.6	Locking operation . . . . .	48	11.14	Reset analysis . . . . .	64
10.7	Logging in/logging out . . . . .	49	11.15	Updating the device software ("firmware") . . . . .	64
10.8	SD card/USB stick . . . . .	49	<b>12</b>	<b>Maintenance . . . . .</b>	<b>64</b>
10.8.1	Operating principle of SD card and USB stick . . . . .	49	12.1	Cleaning . . . . .	65
10.8.2	Functions relating to the SD card or USB stick . . . . .	49	12.1.1	Cleaning of surfaces not in contact with the medium . . . . .	65
10.8.3	Notes on e-mail encryption . . . . .	50	<b>13</b>	<b>Repair . . . . .</b>	<b>65</b>
10.8.4	Notes on WebDAV encryption . . . . .	51	13.1	General notes . . . . .	65
10.8.5	SSL certificates . . . . .	51	13.2	Spare parts . . . . .	65
10.9	Show data logging . . . . .	52	13.3	Return . . . . .	65
10.9.1	Historical data: Change group . . . . .	52	13.4	Disposal . . . . .	65
10.9.2	Historical data: scroll speed . . . . .	52	13.4.1	IT security . . . . .	65
10.9.3	Historical data: Time scaling . . . . .	53	13.4.2	Removing the measuring instrument . . . . .	65
10.9.4	Historical data: Time range displayed . . . . .	53	13.4.3	Disposing of the measuring instrument . . . . .	66
10.9.5	Historical data: Screenshot . . . . .	53	<b>14</b>	<b>Accessories . . . . .</b>	<b>66</b>
10.9.6	Historical data: Change the display mode . . . . .	53	14.1	Device-specific accessories . . . . .	66
10.10	Signal analysis . . . . .	53	14.2	Communication-specific accessories . . . . .	67
10.11	Search in trace . . . . .	54	14.3	Service-specific accessories . . . . .	68
10.12	Changing the display mode . . . . .	54	14.3.1	Software . . . . .	68
10.13	Adjusting the brightness of the display . . . . .	54	14.4	Online tools . . . . .	68
10.14	Limit values . . . . .	54	14.5	System components . . . . .	68
10.15	WebDAV client . . . . .	54	14.6	Instructions for enabling a software option . . . . .	69
10.15.1	Access to the WebDAV server via HTTP (HTML) . . . . .	55	<b>15</b>	<b>Technical data . . . . .</b>	<b>70</b>
			15.1	Function and system design . . . . .	70
			15.2	Input . . . . .	71

---

15.3	Output .....	74
15.4	Electrical connection .....	75
15.5	Performance characteristics .....	77
15.6	Installation .....	78
15.7	Environment .....	79
15.8	Mechanical construction .....	80
15.9	Display and operating elements .....	80
15.10	Certificates and approvals .....	83
15.11	Ordering information .....	83
<b>16</b>	<b>Appendix .....</b>	<b>84</b>
16.1	Operating items in the "Expert" menu .....	84
16.1.1	"System" submenu .....	84
16.1.2	"Inputs" submenu .....	103
16.1.3	"Outputs" submenu .....	126
16.1.4	"Communication" submenu .....	127
16.1.5	"Application" submenu .....	142
16.1.6	"Diagnostics" submenu .....	172

# 1 About this document

## 1.1 Document function

These Operating Instructions contain all the information required in the various life cycle phases of the device: from product identification, incoming acceptance and storage, to installation, connection, operation and commissioning, through to troubleshooting, maintenance and disposal.

## 1.2 Symbols

### 1.2.1 Safety symbols

** DANGER**

This symbol alerts you to a dangerous situation. Failure to avoid this situation will result in serious or fatal injury.

** WARNING**

This symbol alerts you to a potentially dangerous situation. Failure to avoid this situation can result in serious or fatal injury.





** CAUTION**

This symbol alerts you to a potentially dangerous situation. Failure to avoid this situation can result in minor or medium injury.



**NOTICE**









This symbol alerts you to a potentially harmful situation. Failure to avoid this situation can result in damage to the product or something in its vicinity.

### 1.2.2 Electrical symbols



Symbol	Meaning
	Direct current
	Alternating current
	Direct current and alternating current
	<b>Ground connection</b> A grounded terminal which, as far as the operator is concerned, is grounded via a grounding system.
	<b>Protective earth (PE)</b> Ground terminals that must be connected to ground prior to establishing any other connections.  The ground terminals are located on the interior and exterior of the device: <ul style="list-style-type: none"> <li>▪ Interior ground terminal: protective earth is connected to the mains supply.</li> <li>▪ Exterior ground terminal: device is connected to the plant grounding system.</li> </ul>

### 1.2.3 Symbols for certain types of information

Symbol	Meaning
	<b>Permitted</b> Procedures, processes or actions that are permitted.
	<b>Preferred</b> Procedures, processes or actions that are preferred.

Symbol	Meaning
	<b>Forbidden</b> Procedures, processes or actions that are forbidden.
	<b>Tip</b> Indicates additional information.
	Reference to documentation
	Reference to page
	Reference to graphic
	Notice or individual step to be observed
1, 2, 3...	Series of steps
	Result of a step
	Help in the event of a problem
	Visual inspection

### 1.2.4 Symbols in graphics

Symbol	Meaning	Symbol	Meaning
1, 2, 3,...	Item numbers	1, 2, 3...	Series of steps
A, B, C, ...	Views	A-A, B-B, C-C, ...	Sections
	Hazardous area		Safe area (non-hazardous area)

## 1.3 Documentation

 For an overview of the scope of the associated Technical Documentation, refer to the following:

- *Device Viewer* ([www.endress.com/deviceviewer](http://www.endress.com/deviceviewer)): Enter the serial number from the nameplate
- *Endress+Hauser Operations app*: Enter serial number from nameplate or scan matrix code on nameplate.

The following document types are available in the Downloads area of the Endress+Hauser website ([www.endress.com/downloads](http://www.endress.com/downloads)), depending on the product configuration:

Document type	Purpose and content of the document
Technical Information (TI)	<b>Planning aid</b> This document contains all the technical data on the product and provides an overview of everything that can be ordered with the product.
Brief Operating Instructions (KA)	<b>Quick guide to obtaining the first measured value</b> The Operating Instructions contain all the essential information about the product from incoming acceptance to initial commissioning.
Operating Instructions (BA)	<b>Reference</b> The Operating Instructions contain the information that is required in the various phases of the life cycle of the product: From product identification, incoming acceptance and storage, to mounting, connection, operation and commissioning through to troubleshooting, maintenance and disposal.

Document type	Purpose and content of the document
Description of Device Parameters (GP)	<b>Reference for parameters</b> The document contains detailed explanations of readable or configurable parameters in the product. The description is aimed at those who work with the product over its entire life cycle and perform specific configurations.
Safety Instructions (XA)	Safety Instructions for electrical equipment in hazardous areas are supplied with the product depending on the approval. These are an integral part of the Operating Instructions.  The nameplate indicates the Safety Instructions (XA) that are relevant to the product.
Supplementary device-dependent documentation (SD/FY)	Always comply strictly with the instructions in the relevant supplementary documentation. The supplementary documentation is an integral part of the product documentation.

## 1.4 Change history

Device software Version/date	Software changes	FDM analysis software version	Version of OPC server	Operating Instructions
V01.00.00/07.2013	Original software	V01.01.02.10 and higher	V5.00.02.04 and higher	BA01146R/01.13
V01.01.00/02.2014	E-mail via SSL; extended functionality	V01.02.00.08 and higher	V5.00.02.04 and higher	BA01146R/02.14
V02.00.00/08.2015	Extended functionality	V01.03.00.00 and higher	V5.00.03.00 and higher	BA01146R/03.15
V02.01.00/04.2016	Extended functionality/bug fixes	V01.03.01.00 and higher	V5.00.03.00 and higher	BA01146R/04.16
V02.01.05/11.2016	Extended functionality/bug fixes	V01.03.01.01 and higher	V5.00.03.00 and higher	BA01146R/05.16
V02.02.00/11.2017	Ethernet function via USB	V01.04.00 and higher	V5.00.04.00 and higher	BA01146R/06.17
V02.04.00/09.2018	Web server extension	V01.04.02 and higher	V5.00.04.01 and higher	BA01146R/07.18
V02.04.05/08.2021	Support for HTTPS server; bug fixes	V01.04.02 and higher	V5.00.04.01 and higher	BA01146R/08.21
V02.04.09/05.2025	Bug fixes	V01.04.02 and higher	V5.00.04.01 and higher	BA01146R/07.25

## 1.5 Registered trademarks

### Modbus®

Registered trademark of SCHNEIDER AUTOMATION, INC.

### Microsoft®

Registered trademark of Microsoft Corporation, Redmond, Washington, USA

### Google Chrome™ browser

Registered trademark of Google LLC in Mountain View, California, USA

### Internet Explorer®

Registered trademark of Microsoft Corporation

### Microsoft Edge™

Registered trademark of Microsoft Corporation

**Excel™**

Registered trademark of Microsoft Corporation

**Mozilla Firefox®**

Registered trademark of the Mozilla Foundation

**Opera®**

Registered trademark of Opera Software ASA.

## 2 Basic safety instructions

The reliable and safe operation of the device is only ensured if the user reads these Operating Instructions and complies with the safety instructions they contain.

### 2.1 Requirements for the personnel

The personnel for installation, commissioning, diagnostics and maintenance must fulfill the following requirements:

- ▶ Trained, qualified specialists must have a relevant qualification for this specific function and task.
- ▶ Are authorized by the plant owner/operator.
- ▶ Are familiar with federal/national regulations.
- ▶ Before starting work, read and understand the instructions in the manual and supplementary documentation as well as the certificates (depending on the application).
- ▶ Follow instructions and comply with basic conditions.

The operating personnel must fulfill the following requirements:

- ▶ Are instructed and authorized according to the requirements of the task by the facility's owner-operator.
- ▶ Follow the instructions in this manual.

### 2.2 Intended use

 The device is designed for installation in a panel and must only be operated in an installed state.

The device is intended for the electronic capture, display, recording, analysis, remote transmission and archiving of analog and digital input signals in non-hazardous areas.

#### 2.2.1 Product liability

The manufacturer does not accept any responsibility for damage that results from non-designated use and from failure to comply with the instructions in this manual.

### 2.3 Workplace safety

For work on and with the device:

- ▶ Wear the required personal protective equipment according to federal/national regulations.

### 2.4 Operational safety

Damage to the device!

- ▶ Operate the device in proper technical condition and fail-safe condition only.
- ▶ The operator is responsible for the interference-free operation of the device.

### Modifications to the device

Unauthorized modifications to the device are not permitted and can lead to unforeseeable dangers!

- ▶ If modifications are nevertheless required, consult with the manufacturer.

### Repair

To ensure continued operational safety and reliability:

- ▶ Carry out repairs on the device only if they are expressly permitted.
- ▶ Observe federal/national regulations pertaining to the repair of an electrical device.
- ▶ Use only original spare parts and accessories.

## 2.5 Product safety

This state-of-the-art device is designed and tested in accordance with good engineering practice to meet operational safety standards. It left the factory in a condition in which it is safe to operate.

It meets general safety standards and legal requirements. It also complies with the EU directives listed in the device-specific EU declaration of conformity. The manufacturer confirms this by affixing the CE mark.

## 2.6 Safety information for desktop version (option)

- The mains plug should only be inserted into a socket with a ground contact.
- The protective effect may not be suspended by an extension cable without a protective ground.
- Relay outputs:  $U(\max) = 30 V_{\text{eff}}(\text{AC})/60 \text{ V}(\text{DC})$

## 2.7 IT security

The manufacturer only provides a warranty if the device is installed and used as described in the Operating Instructions. The device is equipped with security mechanisms to protect it against any inadvertent changes to the device settings.

IT security measures in line with operators' security standards and designed to provide additional protection for the device and device data transfer must be implemented by the operators themselves.

# 3 Product description

## 3.1 Product design

This device is best suited for the electronic acquisition, display, recording, analysis, remote transmission and archiving of analog and digital input signals.

The device is intended for installation in a panel or cabinet. Operation in a desktop or field housing is possible as an option.

## 4 Incoming acceptance and product identification

### 4.1 Incoming acceptance

On receipt of the delivery:

1. Check the packaging for damage.
  - ↳ Report all damage immediately to the manufacturer.  
Do not install damaged components.
2. Check the scope of delivery using the delivery note.
3. Compare the data on the nameplate with the order specifications on the delivery note.
4. Check the technical documentation and all other necessary documents, e.g. certificates, to ensure they are complete.

 If one of the conditions is not satisfied, contact the manufacturer.

#### 4.1.1 Scope of delivery

The scope of delivery of the device comprises:

- Device (with terminals, according to order)
- Panel-mounted device: 2 screw fastening clips
- USB cable
- Optional: industrial grade SD card (card is located in the SD slot behind the flap on the front of the device)
- "Field Data Manager (FDM)" analysis software (Essential, Demo or Professional version, depending on order)
- Delivery note
- Multilingual Brief Operating Instructions as hard copy

#### 4.1.2 Product identification

The following options are available for identification of the device:

- Nameplate specifications
- Enter the serial number from the nameplate into *Device Viewer* ([www.endress.com/deviceviewer](http://www.endress.com/deviceviewer)): all the information about the device and an overview of the technical documentation supplied with the device are displayed.
- Enter the serial number from the nameplate into the *Endress+Hauser Operations app* or scan the 2-D matrix code (QR code) on the nameplate with the *Endress+Hauser Operations app*: all the information about the device and the technical documentation pertaining to the device is displayed.

#### Nameplate

##### Do you have the correct device?

The nameplate provides you with the following information on the device:

- Manufacturer identification, device designation
- Order code
- Extended order code
- Serial number
- Tag name (TAG) (optional)
- Technical values such as supply voltage, current consumption, ambient temperature, communication-specific data (optional)

- Degree of protection
  - Approvals with symbols
  - Reference to Safety Instructions (XA) (optional)
- Compare the information on the nameplate with the order.

#### Name and address of manufacturer

<b>Name of manufacturer:</b>	Endress+Hauser Wetzer GmbH + Co. KG
<b>Address of manufacturer:</b>	Obere Wank 1, D-87484 Nesselwang or <a href="http://www.endress.com">www.endress.com</a>

## 4.2 Storage and transport

Note the following points:

The permitted storage temperature is  $-20$  to  $+60$  °C ( $-4$  to  $+140$  °F)

-  Pack the device for storage and transportation in such a way that it is reliably protected against impact and external influences. The original packaging offers the best protection.

Avoid the following environmental influences during storage:

- Direct sunlight
- Proximity to hot objects
- Mechanical vibration
- Aggressive media

# 5 Installation

## 5.1 Installation requirements

### NOTICE

#### Overheating due to buildup of heat in the device

- Always ensure adequate cooling of the device to prevent heat accumulation.

The device is designed for use in a panel in non-hazardous areas.

- Ambient temperature range:  $-10$  to  $+50$  °C ( $14$  to  $122$  °F)
- Climate class as per IEC 60654-1: Class B2
- Degree of protection at front: IP65 (NEMA Type 4x encl.)
- Degree of protection at rear: IP20

### 5.1.1 Installation dimensions

- Installation depth: approx. 158 mm (6.22 in) for device incl. terminals and fastening clips
- Panel cutout: 138 to 139 mm (5.43 to 5.47 in) x 138 to 139 mm (5.43 to 5.47 in)
- Panel thickness: 2 to 40 mm (0.08 to 1.58 in)
- Angle of vision: from the midpoint axis of the display,  $75^\circ$  to the left and right,  $65^\circ$  above and below
- A minimum distance of 15 mm (0.59 in) between the devices must be observed if aligning the devices in the Y direction (vertically above one another). A minimum distance of 10 mm (0.39 in) between the devices must be observed if aligning the devices in the X direction (horizontally beside one another).
- Securing to DIN 43 834

## 5.2 Installing the measuring instrument

**i** Mounting tool: A screwdriver is required for installation in the panel.

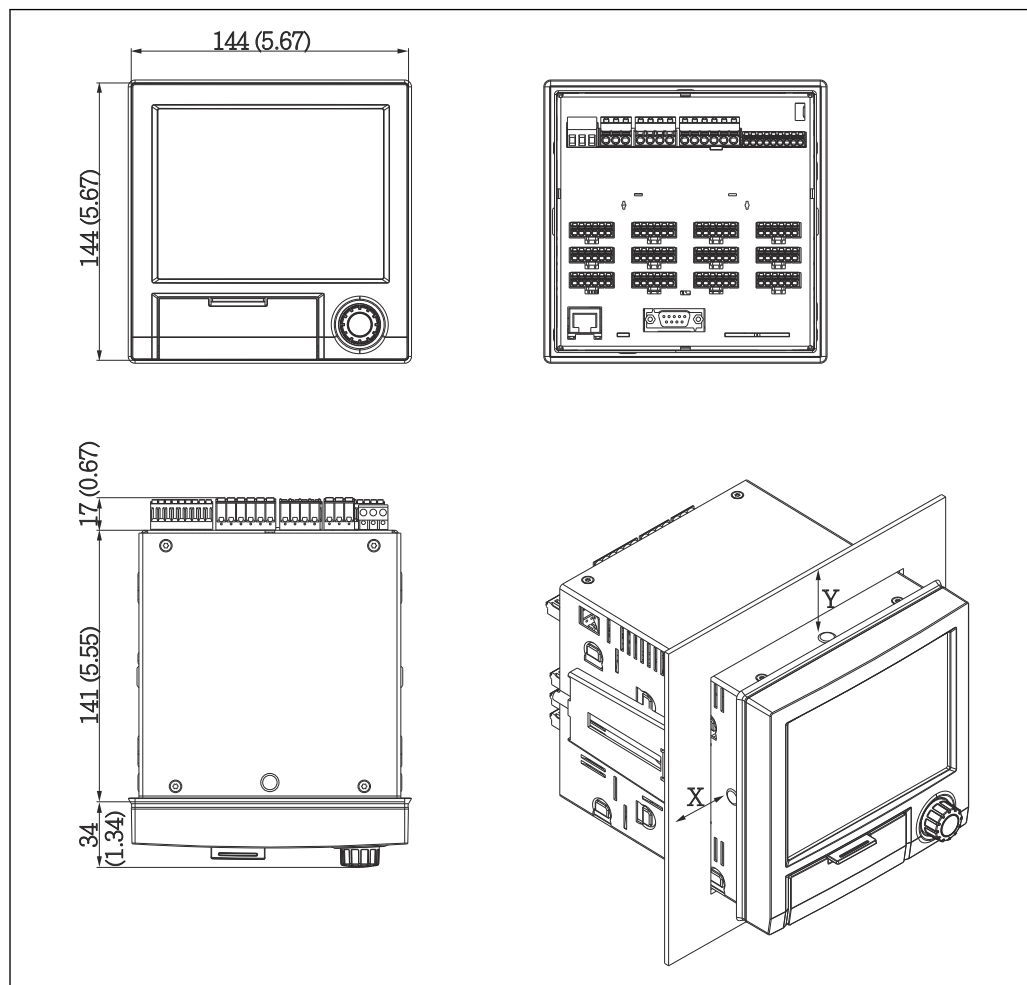

A0019301

**1** Panel mounting and dimensions in mm (inch)

1. Push the device through the panel cutout from the front. To avoid heat buildup, maintain a distance of  $> 15$  mm ( $> 0.59$  in) from walls and other devices.
2. Hold the device level and hook the fastening clips into the openings (1 x left, 1 x right).
3. Evenly tighten the screws on the fastening clip using a screwdriver to guarantee a secure seal to the panel (torque 100 Ncm).

## 5.3 Post-installation check

- Is the sealing ring undamaged?
- Does the seal run all around the housing collar?
- Are the threaded rods properly tightened?
- Is the device fixed firmly in the center of the panel cutout?

## 6 Electrical connection

### 6.1 Connecting requirements

#### WARNING

##### **Danger! Electric voltage**

- ▶ The entire connection of the device must take place while the device is de-energized.
- ▶ The mixed connection of safety extra-low voltage and dangerous contact voltage at the relays is **not** permitted.
- ▶ Apart from the relays and the supply voltage, only energy-limited circuits according to IEC/EN 61010-1 may be connected.

Danger if protective ground is disconnected

- ▶ The protective ground connection must be established before all other connections.

#### NOTICE

##### **Cable heat load**

- ▶ Use suitable cables for temperatures that are 5 °C (9 °F) above the ambient temperature.

Incorrect supply voltage can damage the device or cause malfunctions

- ▶ Before commissioning the device, make sure that the supply voltage matches the voltage specifications on the nameplate.

Check emergency shutdown for device

- ▶ Provide suitable switch or circuit breaker in building installation. This switch must be provided close to the device and marked as a circuit breaker.

Protect the device from overload

- ▶ An overload protection unit (rated current = 10 A) is required for the power cable.

Incorrect wiring may result in the device being destroyed

- ▶ Note terminal designation on the rear of the device.

Energy-rich transients in the case of long signal cables

- ▶ Connect a suitable overvoltage protection system in series upstream (HAW562).

### 6.2 Special connection instructions

#### 6.2.1 Cable specifications

##### **Cable specification, spring terminals**

All connections on the rear of the device are designed as pluggable screw or spring terminal blocks with reverse polarity protection. The spring terminals are unlocked with a slotted screwdriver (size 0).

Note the following when connecting:

- Wire cross-section, auxiliary voltage output, digital I/O and analog I/O: max. 1.5 mm<sup>2</sup> (14 AWG) (spring terminals)
- Wire cross-section, mains: max. 2.5 mm<sup>2</sup> (13 AWG) (screw terminals)
- Wire cross-section, relays: max. 2.5 mm<sup>2</sup> (13 AWG) (spring terminals)
- Stripping length: 10 mm (0.39 in)

 No ferrules must be used when connecting flexible wires to spring terminals.

### Shielding and grounding

Optimum electromagnetic compatibility (EMC) can only be guaranteed if the system components and the cables - both sensor and communication cables - are shielded and the shielding forms as complete a cover as possible. A shielded cable must be used for sensor cables that are longer than 30 m (100 ft). A shield coverage of 90% is ideal. Make sure that the communication cables and sensor cables do not cross when routing them. Connect the shielding as often as possible to the reference ground to ensure optimum EMC protection for the different communication protocols and the connected sensors.

To comply with requirements, three different types of shielding are possible:

- Shielding at both ends
- Shielding at one end on the supply side with capacitance termination at the device
- Shielding at one end on the feed side

The best results are achieved in installations with shielding at one end on the supply side (without capacitance termination at the device). Appropriate internal device wiring measures must be taken to allow unrestricted operation when EMC interference is present. These measures have been taken into account for this device. Operation in the event of disturbance variables as per NAMUR NE21 is thus guaranteed.

Observe national installation requirements and guidelines during installation. Where there are large differences in potential between the individual grounding points, only one point of the shielding is connected directly with the reference ground.

**i** If the shielding of the cable is grounded at more than one point in systems without potential matching, mains frequency equalizing currents can occur. These can damage the signal cable and significantly impact signal transmission. In such cases, the shield of the signal cable should be grounded on one side only and must not be connected to the ground terminal of the housing. The unconnected shield must be insulated.

## 6.3 Connecting the device

### 6.3.1 Terminal assignment on the rear of the device

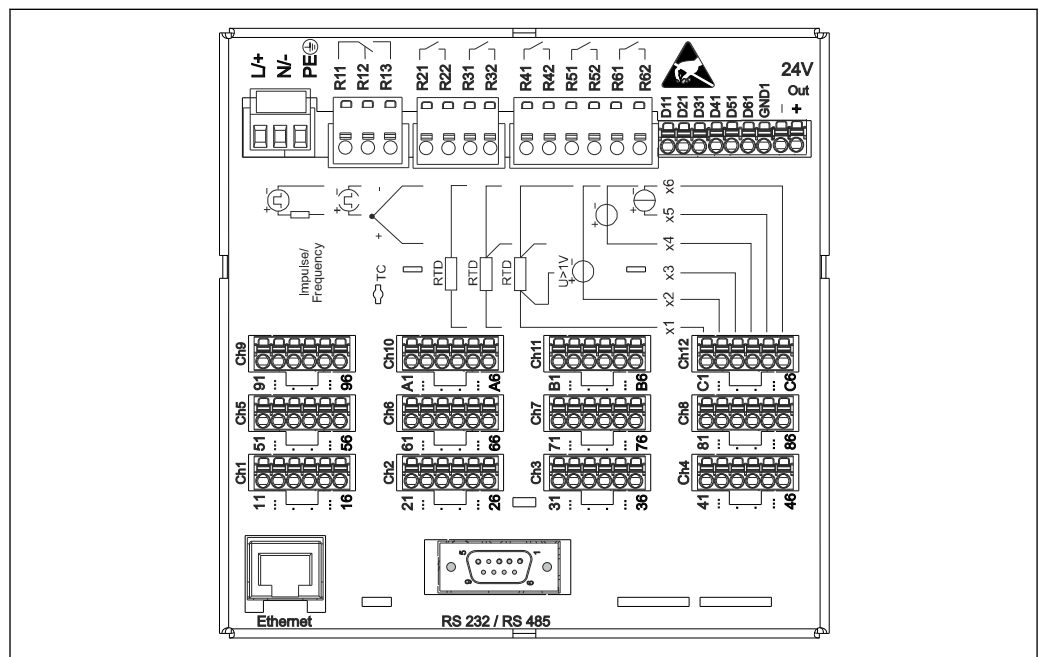

A0019304

**2** Terminals on the rear of the device

### 6.3.2 Supply voltage

Power unit type	Terminal		
100 to 230 V <sub>AC</sub>	L+	N-	PE
	Phase L	Zero conductor N	Ground
24 V AC/DC	L+	N-	PE
	Phase L or +	Zero conductor N or -	Ground

### 6.3.3 Relays

Type	Terminal (max. 250 V, 3 A)				
Alarm relay 1	R11	R12	R13		
	Change-over contact	Normally closed contact (NC) <sup>1)</sup>	Normally open contact (NO) <sup>2)</sup>		
Relays 2 to 6				Rx1	Rx2
				Switching contact	Normally open contact (NO) <sup>2)</sup>

- 1) NC = normally closed (breaker)
- 2) NO = normally open (maker)

### 6.3.4 Digital inputs, auxiliary voltage output

Type	Terminal			
Digital inputs 1 to 6	D11 to D61	GND1		
	Digital input 1 to 6 (+)	Ground (-) for digital inputs 1 to 6		
Auxiliary voltage output, not stabilized, max. 250 mA			24 V Out -	24 V Out +
			- Ground	+ 24 V (±15%)

### 6.3.5 Analog inputs

The first digit (x) of the two-digit terminal number corresponds to the associated channel:

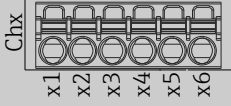
Type	Terminal					
	x1	x2	x3	x4	x5	x6
						
						A0019303
Current/pulse/frequency input <sup>1)</sup>					(+)	(-)
Voltage > 1 V		(+)				(-)
Voltage ≤ 1 V				(+)		(-)
Resistance thermometer RTD (2-wire)	(A)					(B)
Resistance thermometer RTD (3-wire)	(A)			b (sense)		(B)
Resistance thermometer RTD (4-wire)	(A)		a (sense)	b (sense)		(B)
Thermocouples TC				(+)		(-)

- 1) If a universal input is used as a frequency or pulse input and the voltage is > 2.5 V, a series resistor must be used in series connection with the voltage source. Example: 1.2 kΩ series resistor at 24 V

### 6.3.6 Connection example: Auxiliary voltage output as transmitter power supply for 2-wire sensors

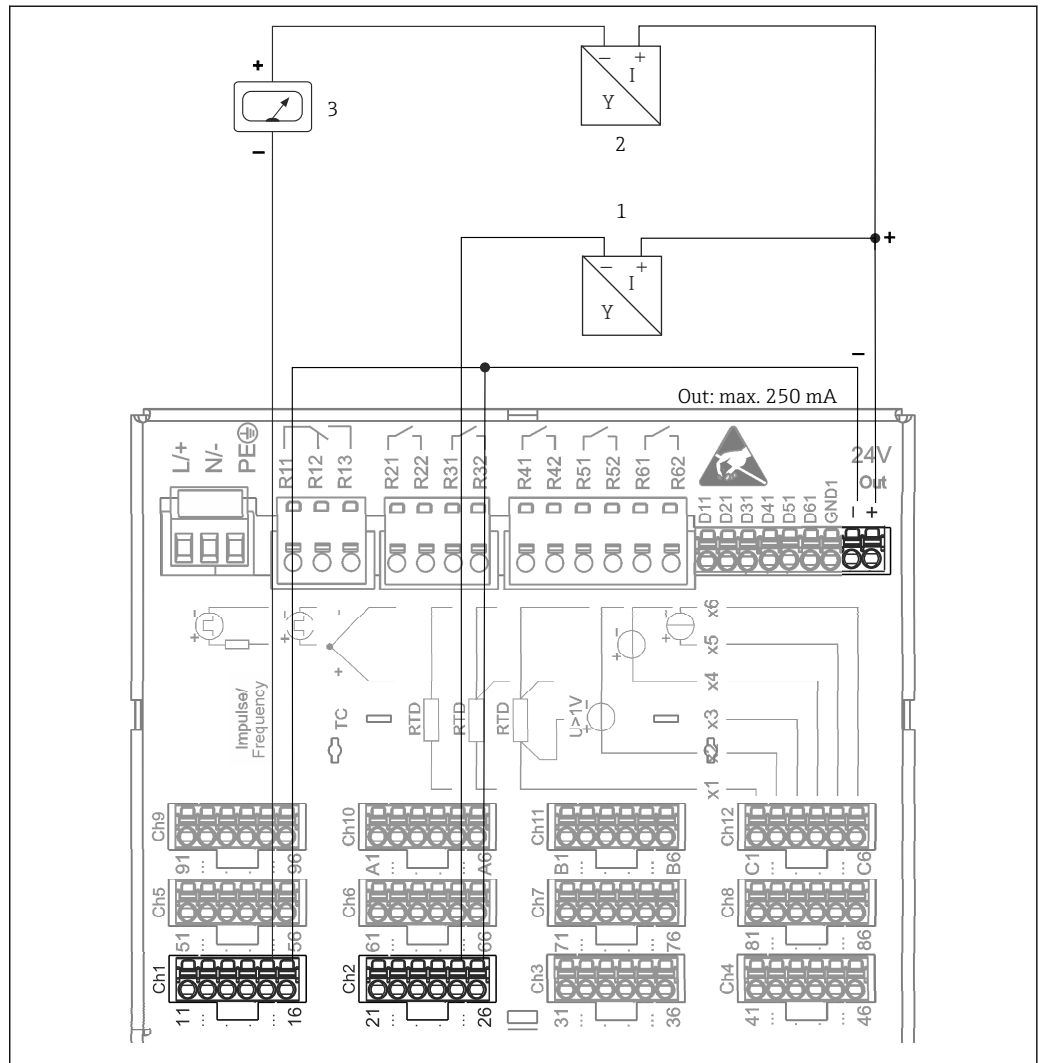

A0020259

3 Connection of the auxiliary voltage output when using as a transmitter power supply for 2-wire sensors in the current measuring range. (When connecting channel CH3-12, see pin assignment CH1-2.)

- 1 Sensor 1 (e.g., Cerabar from Endress+Hauser)
- 2 Sensor 2
- 3 External indicator (optional) (e.g., RIA16 from Endress+Hauser)

### 6.3.7 Connection example: Auxiliary voltage output as transmitter power supply for 4-wire sensors

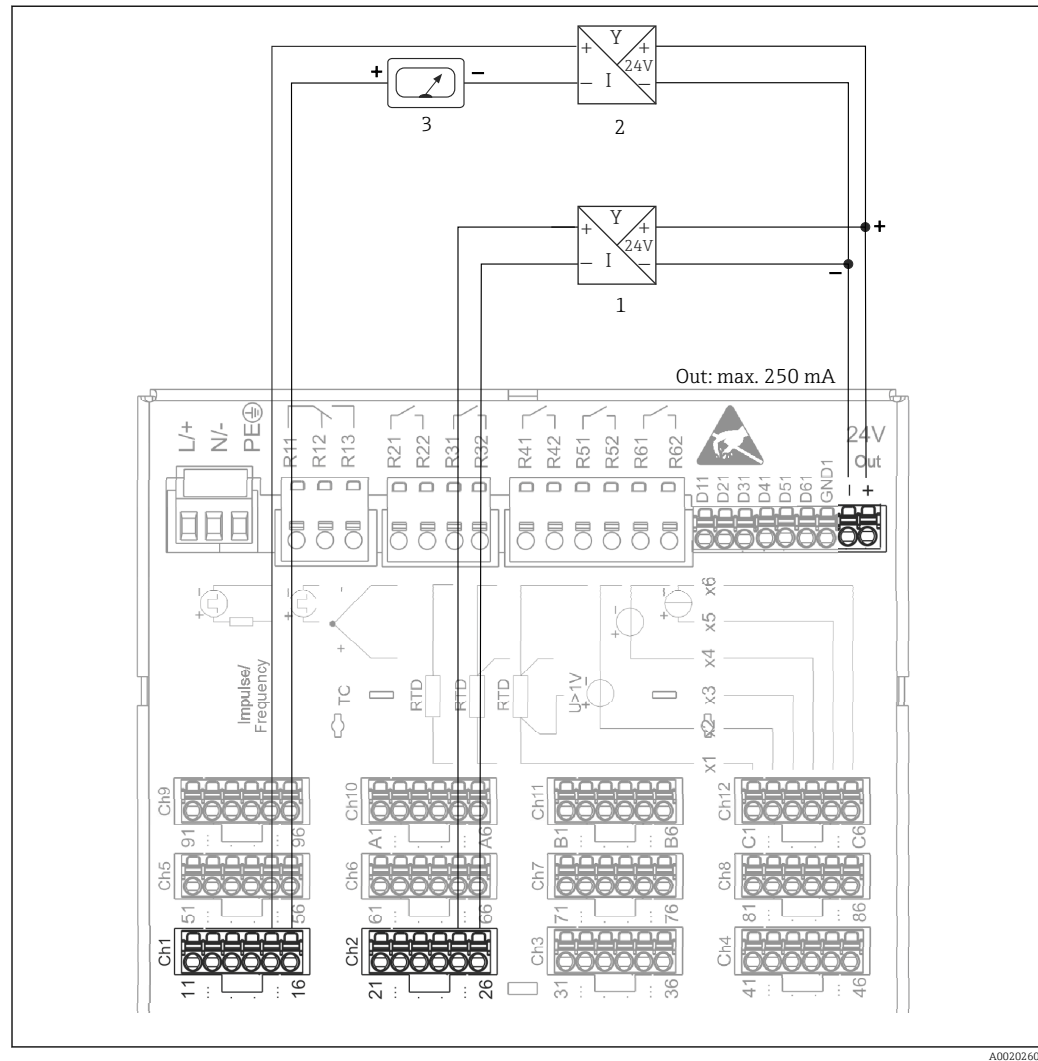

4 Connection of the auxiliary voltage output when using as a transmitter power supply for 4-wire sensors in the current measuring range. (When connecting channel CH3-12, see pin assignment CH1-2.)

- 1 Sensor 1 (e.g., Thermaphant T TTR31 from Endress+Hauser)
- 2 Sensor 2
- 3 External indicator (optional) (e.g., RIA16 from Endress+Hauser)

### 6.3.8 Option: RS232/RS485 interface (rear of device)

 Use shielded signal cables for serial interfaces.

A combined RS232/RS485 connection is available on a shielded SUB D9 socket at the rear of the device. This can be used for data transfer and to connect a modem. For communication via modem, we recommend an industrial modem with a watchdog function.

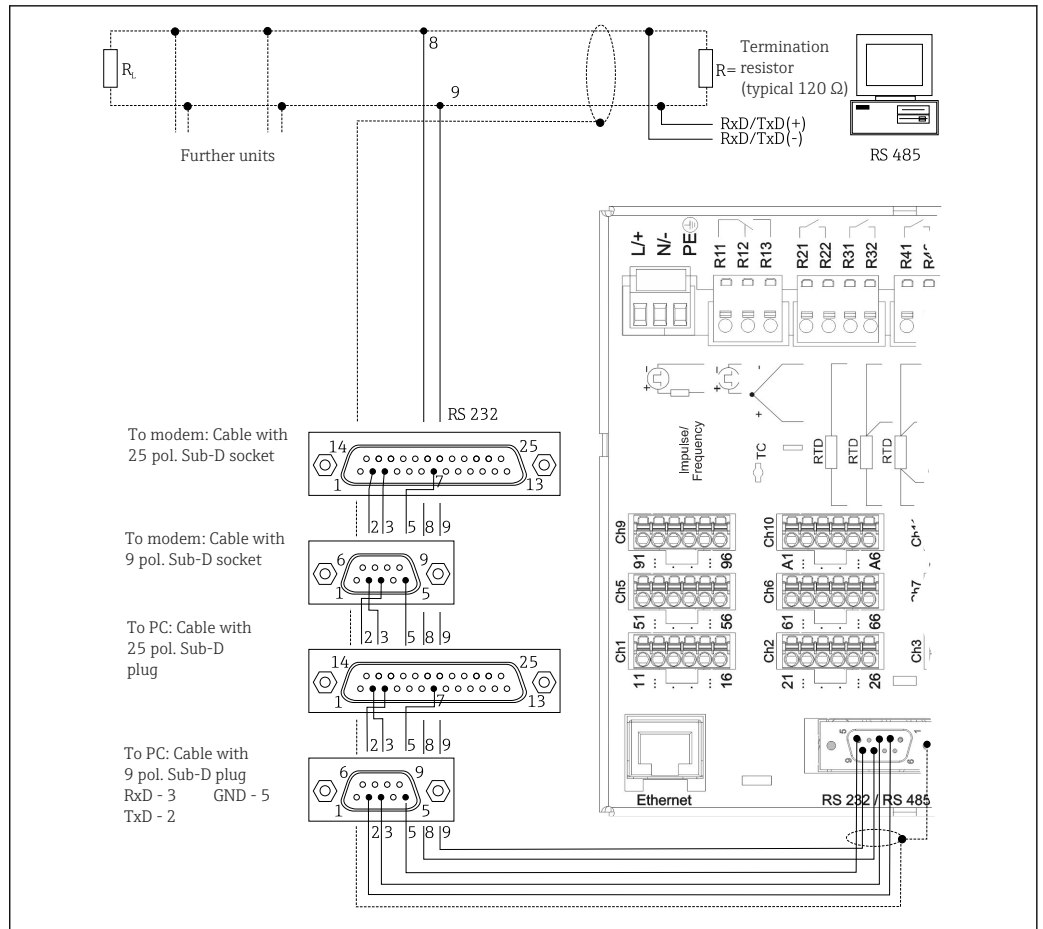

A0019305-EN

Type	Pin of the SUB-D9 socket								
	1	2	3	4	5	6	7	8	9
<b>RS232 assignment</b>		TxD (data output)	RxD (data input)		GND				
<b>RS485 assignment</b>					GND			RxD/TxD -	RxD/TxD +

Unoccupied connections should be left empty.  
 Maximum cable length:  
 RS232: 2 m (6.6 ft)  
 RS485: 1 000 m (3 280 ft)

**i** Only one interface can be used at any one time (RS232 or RS485).

### 6.3.9 Ethernet connection (rear of device)

The Ethernet interface can be used to integrate the device into a PC network (TCP/IP Ethernet) via a hub or switch. A standard patch cable (e.g., CAT5E) can be used for the connection. Using DHCP, the device can be fully integrated into an existing network without the need for additional configuration. The device can be accessed from every PC in the network.

- Standard: 10/100 Base T/TX (IEEE 802.3)
- Socket: RJ-45
- Max. cable length: 100 m
- Galvanic isolation

### Meaning of the LEDs

Beneath the Ethernet connection (see rear of device) there are two light emitting diodes which indicate the status of the Ethernet interface.

- Yellow LED: link signal; is lit when the device is connected to a network. If this LED is not lit, communication is not possible.
- Green LED: Tx/Rx; flashes irregularly if the device is transmitting or receiving data.

### 6.3.10 Option: Ethernet Modbus TCP slave

The Modbus TCP interface is used to connect to higher-ranking SCADA systems (Modbus master) to transmit all measured values and process values. Up to 12 analog inputs and 6 digital inputs can be transmitted via Modbus and stored in the device. The Modbus TCP interface is physically identical to the Ethernet interface.

### 6.3.11 Option: Modbus RTU slave

The Modbus RTU (RS485) interface is galvanically isolated and is used to connect to higher-level systems to transmit all measured values and process values. Up to 12 analog inputs and 6 digital inputs can be transmitted via Modbus and stored in the device. Connection is via the combined RS232/RS485 interface.

 Modbus TCP and Modbus RTU cannot be used at the same time.

### 6.3.12 Connections at front of device

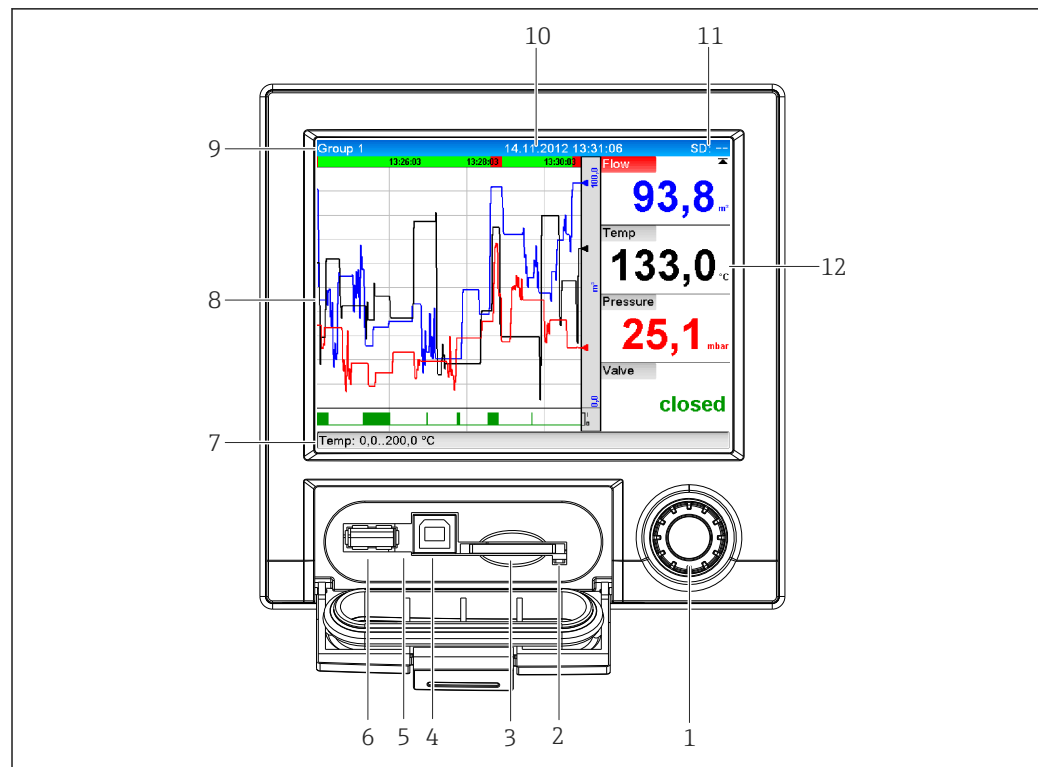

 5 Front of device with open flap

- 1 Navigator
- 2 LED at SD slot. Orange LED flashes when the device is writing to or reading from the SD card.
- 3 Slot for SD card
- 4 USB-B socket "Function", e.g., to connect to PC or laptop
- 5 Green LED lit: power supply present
- 6 USB-A socket "Host", e.g., for USB memory stick or external keyboard
- 7-12 For a description of the display formats, see the "Operation options" section

**USB connection type A (host)**

A USB 2.0 port is available on a shielded USB-A socket at the front of the device. A USB stick can be connected to this interface as a storage medium. An external keyboard or USB hub may also be connected.

**USB connection type B (function)**

A USB 2.0 port is available on a shielded USB-B socket at the front of the device. This can be used to connect the device to a laptop for communication. →  31

 USB-2.0 is compatible with USB-1.1 and USB-3.0, i.e., communication is possible.

**Information on USB devices**

*Requirements with regard to an external USB hub*

The USB devices are detected by the "plug-and-play" function. If several devices of the same type are connected, only the USB device that was connected first is available. Settings for the USB devices are made in the setup. A maximum of 8 external USB devices (incl. USB hub) can be connected if they do not exceed the maximum load of 500 mA. If overloaded, the corresponding USB devices are automatically disabled.

*Requirements with regard to the USB stick*

There is no guarantee that all manufacturers' USB sticks will function faultlessly. An industrial grade SD card is recommended to ensure the reliable recording of data. →  66

 The USB stick must be formatted to FAT/FAT32. NTFS format is not readable. The system supports only USB sticks with max. 32 GB.



 Do not connect the USB stick to the device via a USB hub. Interference from other USB devices may result in data loss.

*Requirements with regard to an external USB keyboard*

The system only supports keyboards which can be addressed using generic drivers (HID keyboard - Human Interface Device). Special buttons are not supported (e.g., the Windows button). Users can only enter characters that are available in the input character set of the device. All unsupported characters are rejected. It is not possible to connect a wireless keyboard. The following keyboard layouts are supported: DE, CH, FR, USA, USA International, UK, IT. See setting under "Setup -> Advanced setup -> System -> Keyboard layout".

**Requirements with regard to the SD card**

Industrial grade SD-HC cards with max. 32 GB are supported.

 Use only the industrial grade SD cards described in the "Accessories" section of the Operating Instructions. These have been tested by the manufacturer and are guaranteed to function correctly in the device. →  66

 The SD card must be formatted to FAT/FAT32. NTFS format is not readable.

**6.4 Post-connection check**

Device condition and specifications	Notes
Are cables or the device damaged?	Visual inspection
Electrical connection	Notes
Does the supply voltage match the information on the nameplate?	-

Are all terminals firmly engaged in their correct slot?	-
Are the mounted cables strain-relieved?	-
Are the power supply and signal cables correctly connected?	See connection diagram and rear of device.

## 7 Operating options

### 7.1 Overview of operating options

The device can be operated directly on site with the navigator and USB keyboard/mouse or via interfaces (serial, USB, Ethernet) and operating tools (web server); FieldCare/ DeviceCare configuration software).

### 7.2 Structure and function of the operating menu

 The layout and structure of the operating menu can differ slightly in parts on the web server.

### 7.2.1 Operating menu for operators and maintenance personnel

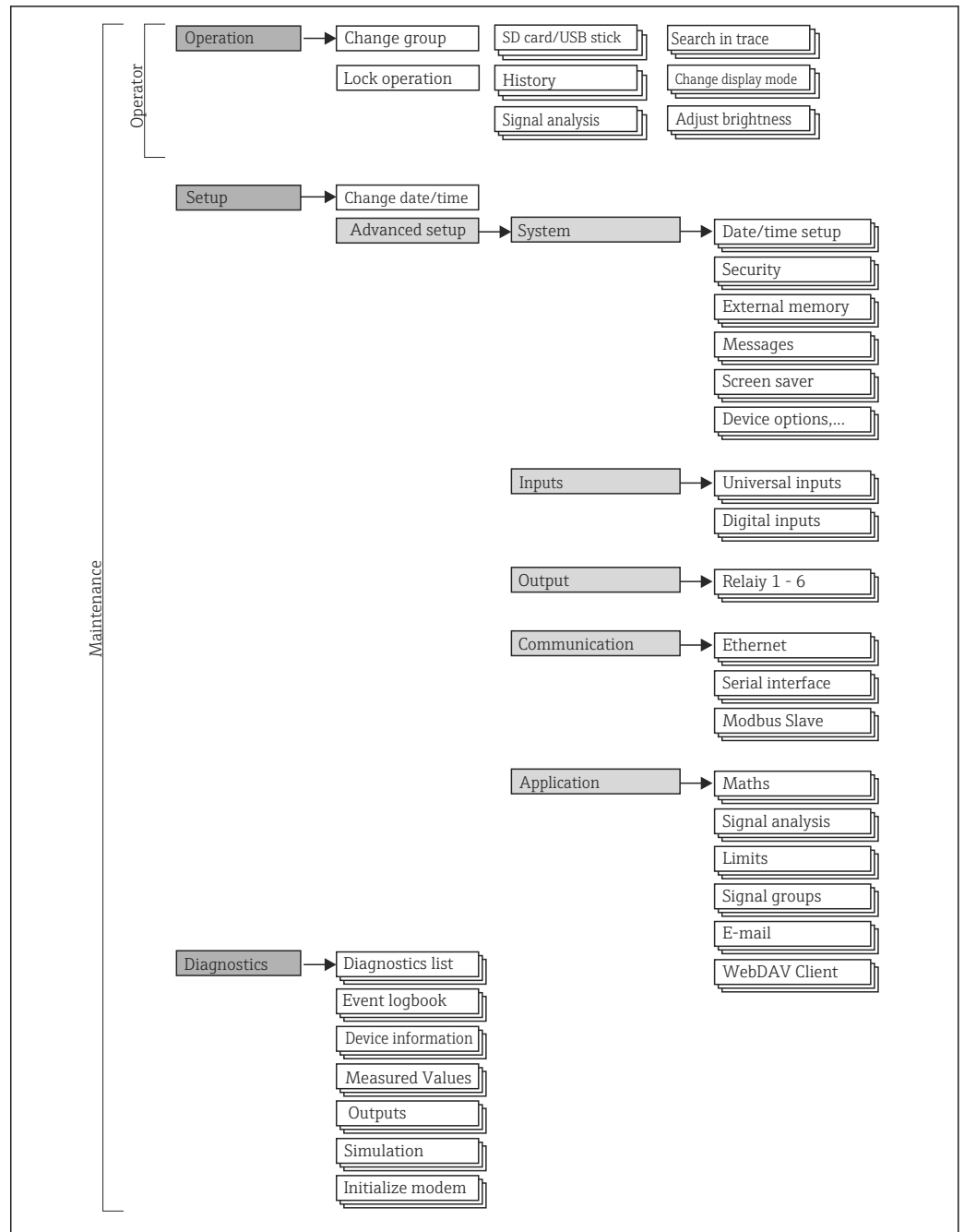

A0019594-EN

### 7.2.2 Operating menu for experts

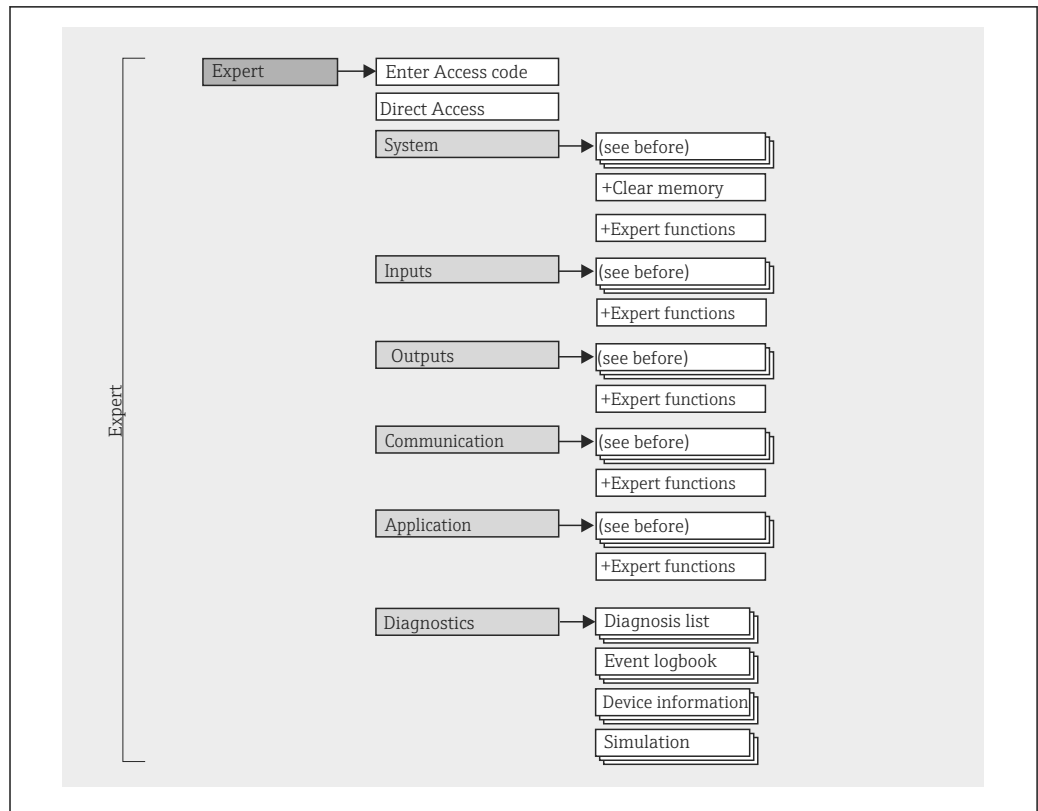

A0019596-EN

### 7.2.3 Submenus and users

Certain parts of the menu are assigned to certain user roles. Each user role corresponds to typical tasks within the life cycle of the device.

User role	Typical tasks	Menu	Content/meaning
Operator	Tasks during operation: <ul style="list-style-type: none"> <li>▪ Configuration of the display.</li> <li>▪ Reading measured values.</li> </ul>	"Operation"	Contains all the parameters that are required in ongoing operation: configuration of the measured value display (displayed values, display format, etc.).
Maintenance	Commissioning: <ul style="list-style-type: none"> <li>▪ Configuration of the measurement.</li> <li>▪ Configuration of data processing.</li> </ul>	"Setup"	Contains all of the parameters for commissioning: <ul style="list-style-type: none"> <li>▪ <b>Change date/time</b></li> <li>▪ <b>"Advanced setup" submenu</b> Contains additional submenus and parameters:                             <ul style="list-style-type: none"> <li>▪ <b>System:</b> Basic settings required for operating the device.</li> <li>▪ <b>Inputs:</b> Settings for analog and digital inputs.</li> <li>▪ <b>Outputs:</b> Settings required only if outputs (e.g., relays) are to be used.</li> <li>▪ <b>Communication:</b> Settings required if the USB, RS232, RS485 or Ethernet interface of the device is used (PC operation, serial data read-out, modem operation, etc.).</li> <li>▪ <b>Application:</b> Various application-specific settings (e.g., group settings, limit values etc.).</li> </ul> </li> </ul> Once values have been set for these parameters, the measurement should usually be fully configured.

User role	Typical tasks	Menu	Content/meaning
	<p>Troubleshooting:</p> <ul style="list-style-type: none"> <li>▪ Diagnosing and eliminating process errors.</li> <li>▪ Interpretation of device error messages and correcting associated errors.</li> </ul>	<p>"Diagnostics"</p>	<p>Contains all parameters for detecting and analyzing errors:</p> <ul style="list-style-type: none"> <li>▪ <b>Diagnostic list</b> All diagnostic messages are listed in chronological order.</li> <li>▪ <b>Event logbook</b> Events, such as limit value violations and power failures are listed in chronological order.</li> <li>▪ <b>Device information</b> Displays important device information (e.g., serial number, firmware version, device options for hardware and software, memory information, etc.).</li> <li>▪ <b>Measured values</b> Displays the current measured values of the device.</li> <li>▪ <b>Outputs</b> Displays the current status of the outputs, e.g., switch status of relay outputs.</li> <li>▪ <b>Simulation</b> Various functions/signals can be simulated for test purposes here. <b>Note:</b> In Simulation mode, normal recording of the measured values is interrupted and the intervention is logged in the event logbook.</li> <li>▪ <b>Initialize modem</b> Initializes the modem connected to the serial interface (for automatic call answering).</li> </ul>
<p>Expert</p>	<p>Tasks that require detailed knowledge of the device's functionality:</p> <ul style="list-style-type: none"> <li>▪ Commissioning measurements under difficult conditions.</li> <li>▪ Optimal adaptation of the measurement to difficult conditions.</li> <li>▪ Detailed configuration of the communication interface.</li> <li>▪ Error diagnostics in difficult cases.</li> </ul>	<p>"Expert"</p>	<p>Contains all the parameters of the device (including those already contained in one of the other menus). The expert menu is protected by a code. Factory setting: 0000. This menu is structured according to the function blocks of the device:</p> <ul style="list-style-type: none"> <li>▪ <b>"System" submenu</b> Contains all higher-level device parameters that do not affect measurement or measured value communication.</li> <li>▪ <b>"Inputs" submenu</b> Contains all parameters for configuring the analog and digital inputs.</li> <li>▪ <b>"Output" submenu</b> Contains all parameters for configuring the outputs (e.g., relays).</li> <li>▪ <b>"Communication" submenu</b> Contains all parameters for configuring the communication interfaces.</li> <li>▪ <b>"Application" submenu</b> Contains all the parameters for configuring the application-specific settings (e.g., group settings, limit values etc.).</li> <li>▪ <b>"Diagnostics" submenu</b> Contains all parameters needed to detect and analyze operational errors.</li> </ul>

### 7.3 Measured value display and operating elements

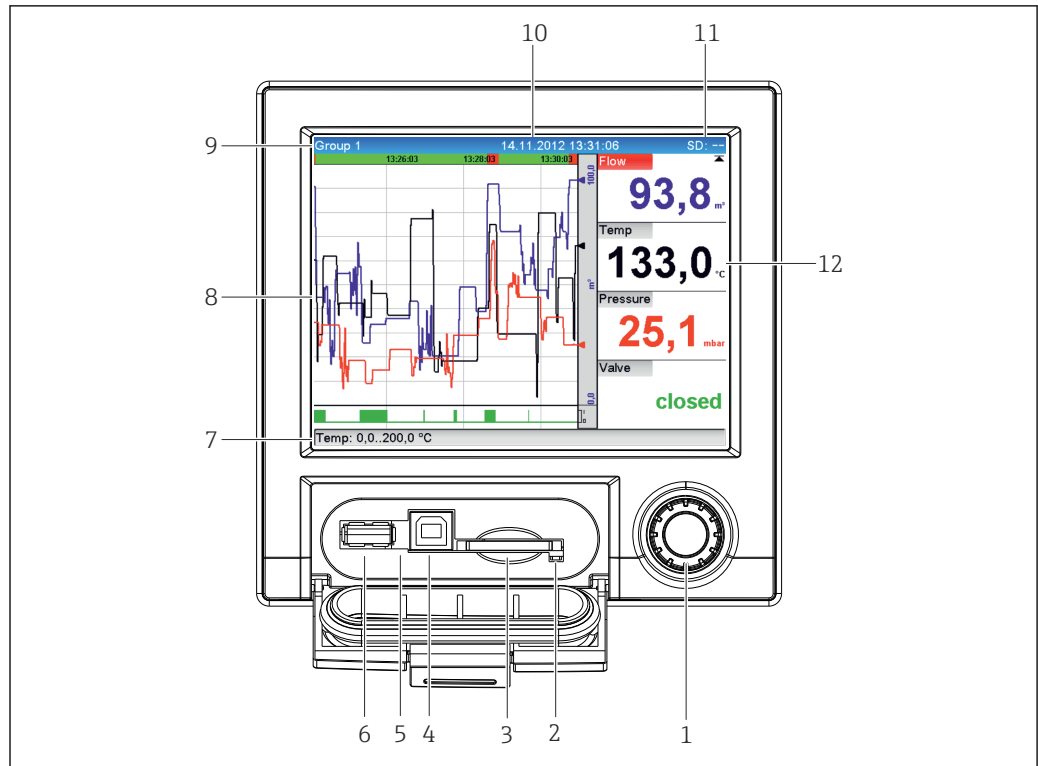





A0047011



6 Front of device with open flap

Item no.	Operating function (display mode = display of measured values) (Setup mode = operation in the Setup menu)
1	"Navigator": Jog/shuttle dial for operating with additional press/hold function.  In display mode: turn the dial to switch between the various signal groups. Press the dial to display the main menu.  In setup mode or in a selection menu: Turn the dial anticlockwise to move the bar or the cursor up or to the left, changes the parameter. Turning clockwise moves the bar or cursor down or clockwise, changes parameter. Press briefly (<2 sec.) = Select highlighted function, parameter change starts (ENTER key).  <b>i</b> Access online help: Press and hold navigator (>3 sec.) to show information on the selected function. To quit the menu immediately, press and hold "Back" (>3 sec.) in the navigator. The device switches to display mode.
2	LED at SD slot. Orange LED lit when the device is accessing the SD card. <b>Do not remove the SD card if the LED is lit! Risk of data loss!</b>
3	Slot for SD card
4	USB-B socket "Function", e.g., to connect to a PC or laptop
5	Green LED lit: power supply present
6	USB-A socket "Host", e.g., for USB memory stick or external keyboard
7	In display mode: alternating status display (e.g., set zoom range) of the analog or digital inputs in the appropriate color of the channel.  In setup mode: different information can be displayed here depending on the display type.
8	In display mode: window for measured value display (e.g., curve display).  In setup mode: displays the operating menu





Item no.	Operating function (display mode = display of measured values) (Setup mode = operation in the Setup menu)
9	In display mode: current group name, type of analysis  In setup mode: name of the current operating item (dialog title)
10	In display mode: displays current date/time In setup mode: --
11	In display mode: alternating display indicating the percentage space on the SD card or USB stick that has already been used. Status symbols are also displayed in alternation with the memory information (see the following table).  In setup mode: the current "direct access" operating code is displayed
12	In display mode: the current measured values are displayed and, in the event of an error/alarm condition, the status is displayed. In the case of counters, the type of counter is displayed as a symbol (see the following table).   If a measuring point has limit value status, the corresponding channel identifier is highlighted in red (quick detection of limit value violations). During a limit value violation and device operation, the acquisition of measured values continues uninterrupted.

## 7.4 Display representation of symbols used in operation









Item no.	Function	Description
8, 12	<b>Symbols for counters:</b>	
	ΣI	Intermediate analysis/external analysis
	ΣD	Daily analysis
	ΣM	Monthly analysis
	ΣY	Annual analysis
	Σ	Totalizer
8, 12	<b>Channel-related symbols:</b>	
		Violation of lower limit value
		Violation of upper limit value or limit value on counter
		Violation of upper and lower limit values at the same time
	<b>S</b>	<b>"Out of specification"</b> e.g., input signal too high/low
	<b>F</b>	<b>Error message "Failure detected"</b> An operating error has occurred. The measured value is no longer valid (e.g., a channel not displayed in the current group is defective).
	<b>M</b>	<b>"Maintenance required"</b> Maintenance is required. The measured value remains valid.
	-----	<b>Error, measured value not displayed.</b> Possible causes: Sensor / input error, line break, invalid value, input signal too high/low
11	<b>Symbol for status signals:</b>	
		<b>"Device locked"</b> Setup is locked via a control input. Disable setup lock via a control input.
	<b>S</b>	<b>"Out of specification"</b> The device is being operated outside its technical specifications (e.g., during startup or cleaning processes).
	<b>C</b>	<b>"Function check"</b> The device is in Service mode.

Item no.	Function	Description
	<b>M</b>	<b>"Maintenance required"</b> Maintenance is required. The measured value remains valid.
	<b>F</b>	<b>Error message "Failure detected"</b> An operating error has occurred. The measured value is no longer valid (e.g., a channel not displayed in the current group is defective).
		<b>"External communication"</b> The device is communicating externally (e.g., via Modbus).
	<b>SIM</b>	<b>"Simulation"</b> Simulation is active.
7		<b>"Historical data"</b> Historical data are currently shown on screen.

### 7.4.1 Symbols in operating menus

	Symbol for setup
	Symbol for diagnostics
	Symbol for expert setup
	Back The function "Back" appears at the end of each menu/submenu. Press "Back" briefly to go up one level in the menu structure.  Press and hold "Back" (>3 sec.) to quit the menu immediately. The device switches to display mode.

### 7.4.2 Symbols in the event logbook

	Setup changes
	Power on
	Power off
	Limit value on
	Limit value off
1	Digital on (on/off message)
0	Digital off (on/off message)
	Service
	Texts saved/comments added
<b>OK</b>	Acknowledging message
	Back
	Continue searching

## 7.5 Entering text and numbers (virtual keyboard)

A virtual keyboard is available for entering text and numbers. This is opened automatically if needed. The appropriate character is selected by turning and pressing the navigator.

The following characters are available for entering customized text:

0-9 a-z A-Z = + - \* / \ ^ 2 3 1/4 1/2 3/4 ( ) | | < > { } I ? ! ` " ' ^ % ° . , : \_ μ & # \$ € @ \$ £ ¥ ~

←	Jump one position to the left. If this symbol is selected, the cursor jumps one position to the left.
→	Jump one position to the right. If this symbol is selected, the cursor jumps one position to the right.
←x	Delete backwards. If this symbol is selected, the character to the left of the cursor position is deleted.
x→	Delete forwards. If this symbol is selected, the character to the right of the cursor position is deleted.
<b>C</b>	Delete all. If this symbol is selected, the entire entry is deleted.
<b>X</b>	Reject entry. If this symbol is selected, the entry is rejected and you quit editing mode. The previously set text remains.
✓	Accept entry. If this symbol is selected, the entry is applied at the position specified by the user, and you quit editing mode.

## 7.6 Channel color assignment

Channel color assignment is performed in the main menu under **"Setup -> Advanced setup -> Application -> Signal groups -> Group x"**. 8 predefined colors are available per group and can be assigned to the desired channels.

## 7.7 Access to operating menu via local display

Using the "Navigator" (jog/shuttle dial with additional press/hold function), all settings can be made directly on site at the device.

## 7.8 Device access via operating tools

### 7.8.1 Field Data Manager (FDM) analysis software (SQL database support)

The PC analysis software offers external, centralized data management with visualization for recorded data. The analysis software enables the complete archiving of all measuring point data, e.g., measured values, diagnostic events and protocols. The analysis software stores data in an SQL database. The database can be operated locally or in a network (client/server). Access is via RS232/RS485, USB or Ethernet interface (network).

Function scope:

- Export of saved data (measured values, analyses, event logbook)
- Visualization and processing of saved data (measured values, analyses, event logbook)
- Safe archiving of exported data in an SQL database

The following versions of the software are available:

- Essential version (free, with limited functionalities)
- Professional version (see Accessories →  66)
- Demo version (time-limited Professional version)



 An "Essential" version of the analysis software can be downloaded free of charge at [www.endress.com/ms20](http://www.endress.com/ms20).

 For details, see the online help in the analysis software and the Operating Instructions for the analysis software.

## 7.8.2 Web server

A web server is integrated into the device. This makes the current measured values of the device available in real time. Access is via an Ethernet interface from a PC in the network via the standard browser. The installation of additional software is not required. Alternatively, the web server can be operated via the USB-B interface in a point-to-point connection (Ethernet over USB) using a standard USB cable. →  31

The web server offers the following functionality:

- Display of current and historical data and measured value curves via a standard web browser →  41
- Easy configuration without additional installed software →  34
- Remote access to device and diagnostic information

## 7.8.3 OPC server (optional)

The OPC server makes it possible to access data on the device. These data are made available to OPC clients in real time. The OPC server meets the requirements of the OPC specifications regarding the supply of data to an OPC client. Access is via RS232/RS485, USB or Ethernet interface (network). Communication takes place using automatic device detection; the operator does not need to make any additional settings. The OPC server enables the flexible and powerful exchange of data and is easy and convenient to use.

The following instantaneous values can be provided:

- Analog channels
- Digital channels
- Mathematics
- Totalizer



For details, see Operating Instructions BA00223R

## 7.8.4 FieldCare/DeviceCare configuration software

### Function scope

The configuration software is an FDT/DTM-based system asset management tool. It can be used to configure all intelligent field units in a plant and helps you manage them. By using the status information, it is also a simple but effective way of checking their status and condition. Access is via USB or Ethernet interface (network).

Typical functions:

- Device configuration
- Loading and saving device data (upload/download)
- Documentation of the measuring point



Download at: [www.endress.com/download](http://www.endress.com/download)

*Overview of device description files (DTM)*

Information and files are available free of charge at:



See online at: [www.de.endress.com/fieldcare](http://www.de.endress.com/fieldcare)

## 8 System integration

### 8.1 Integrating the measuring instrument into the system

#### 8.1.1 General information

The device has (optional) fieldbus interfaces for exporting process values. Measured values and statuses can also be transmitted to the device via fieldbus.

Note: Counters cannot be transferred.

Depending on the bus system, alarms and faults occurring during data transmission are displayed (e.g., status byte).

The process values are transmitted in the same units that are used to display the values on the device.

#### 8.1.2 Ethernet

**Setup** → **Advanced setup** → **Communication** → **Ethernet**

The IP address can be entered manually (fixed IP address) or assigned automatically using DHCP.

The port for data communication is preset to 8000. The port can be changed in the **Expert** → **Communication** → **Ethernet** menu.

The following functions are implemented:

- Data communication with PC software (analysis software, configuration software, OPC server)
- Web server

The following connections are possible at the same time:

- 1x Port 8000 (configuration software, OPC server or analysis software)
- 1x Port 8002 (OPC server only)
- 4x Modbus slave TCP
- 5x Web server

 Ports can be changed.

As soon as the maximum number of connections has been reached, new connection attempts are blocked until an existing connection has been terminated.

#### 8.1.3 Web server with "Ethernet over USB" function

To provide easy and efficient access via web server for operation, setup and commissioning, the USB-B interface can be switched to the "Ethernet over USB" mode. Ethernet communication is established here via the USB interface. This has the advantage that the Ethernet interface in the case of commissioning laptops, for example, does not need to be reconfigured (IP address, ports, etc.). Instead, a standard USB cable can be used

to establish a point-to-point connection. The web server itself retains its complete range of functionality.

#### **Important information:**

- Do not connect several devices via USB to a laptop/PC at the same time.
- The PC should not be connected to the device via USB and to the network via Ethernet/RJ45 at the same time if the network uses the same address range as the device.
- Driver software (EH ECM device) must be installed on the PC.
- The "Ethernet over USB" mode is not a gateway, i.e., the Ethernet/RJ45 and USB networks are separate from each other (no two-way access).
- The USB cable should be disconnected from the device for at least 10 s before being reconnected (prevention of errors due to response time of system).
- It takes at least 10 s before the USB driver is activated by Windows and communication with the device is possible.
- Initialization of the USB interface takes place when the PC and device are connected via a USB cable.

#### **Supported services/functions**

The following services/functions are provided via the USB interface:

- Web server
- CDI TCP (port 8000)
- WebDAV server

All other services/functions are available only by Ethernet via RJ45.

#### **Driver installation at PC end**

To use the web server via USB, a driver must be installed once at the PC end.

1. Download "USB\_ECM.zip" at [www.endress.com](http://www.endress.com)
2. Execute the "setup.exe" and follow the instructions.

The necessary drivers are installed.

#### **Changing the USB-B mode to "Ethernet over USB" (panel version)**

Communication can be established only if the device has been configured accordingly.



1. Supply power to the device, restart and wait for start screen.
2. Open dropdown menu under **"Setup → Advanced setup → Communication → Function USB-B"**.
3. "Always USB" option: USB-B is always set to Standard USB.
4. "Always Ethernet over USB" option: Ethernet over USB is always set.
5. "As per user entry" option: A prompt for the mode (option) appears once a USB cable is plugged in.

The device is now ready to establish a connection.

#### **Establishing communication**

1. Using a standard USB cable, connect the device at the USB-B interface to any of the PC's USB interfaces.
2. With "Always Ethernet over USB" function: The web server can be started immediately.
3. With "As per user prompt" function: Once the USB cable has been plugged into the device, the "Select USB function" dropdown menu appears. Then select "Ethernet over USB" on the device. The device returns the IP address.
4. Open the browser, enter <http://192.168.1.212> and follow the instructions from section →  42

The device is now ready to communicate with the web server.

-  The IP address of the web server via USB is set permanently to <http://192.168.1.212>
-  If the USB cable is already connected to a PC when the device starts up, there is no prompt even if the "As per user entry" option is selected. Instead, the previously selected functionality is used.

### 8.1.4 Modbus RTU/TCP slave

The device can be connected to a Modbus system via RS485 or Ethernet interface. The general settings for the Ethernet connection are made in the **Setup** → **Advanced setup** → **Communication** → **Ethernet** menu. Modbus communication is configured in the **Setup** → **Advanced setup** → **Communication** → **Modbus Slave** menu.

Up to 12 analog inputs and 6 digital inputs can be transmitted via Modbus and stored in the device.

Menu item	RTU (RS485)	Ethernet
Device address:	1 to 247	IP address manual or automatic
Baud rate:	9600/ <b>19200</b> /38400/57600/115200	-
Parity:	Even/Odd/ <b>None</b>	-
Stop bits:	1/2	-
Port:	-	502

#### Transfer of values

The actual Modbus TCP protocol is located between layer 5 to 6 in the ISO/OSI model.



To transfer a value, 3 registers of 2 bytes each (2-byte status + 4-byte float) or 5 registers of 2 bytes each (2-byte status + 8-byte double) are used.

-  For more information on Modbus, see the supplementary documentation.

## 9 Commissioning

### 9.1 Function check

Perform the following checks prior to commissioning:

- "Post-installation check" checklist →  12.
- "Post-connection check" checklist →  21.

### 9.2 Switching on the measuring instrument

After the operating voltage is applied, the green LED lights up and the device is ready for operation.

If you are commissioning the device for the first time, program the setup as described in the following sections of the Operating Instructions.

If you are commissioning a device that is already configured or preset, the device starts measuring immediately as defined in the settings. The values of the channels currently activated are shown on the display.

-  Remove the protective film from the display as this would otherwise affect the readability of the display.



## 9.3 Configuring the operating language

Factory setting: English or ordered local language

### Calling the main menu, configuring the operating language:

1. Press the navigator.
2. The main menu appears on the display with the "Sprache/Language" option.
3. To change the set language: Press the navigator, turn the navigator to select the desired language and press the navigator to apply the change.
4. Use "Back" or "ESC" to quit the main menu.

The operating language has been changed.

 The function  "Back" appears at the end of each menu/submenu.

Press "Back" briefly to go up one level in the menu structure.

To quit the menu immediately and return to the measured value display, press and hold "Back" (>3 sec.). The changes made are accepted and saved.

## 9.4 Configuring the measuring instrument (Setup menu)

Access to the setup is enabled when the device leaves the factory and can be locked in various ways, e.g., by entering a 4-digit access code or via role-based password protection.

When locked, basic settings can be checked but not changed. The device can also be put into operation and configured via the PC.

Device configuration options:

- Setup directly at the device (panel-mounted device only)
- Setup via SD card or USB stick by transferring the parameters stored on it
- Setup via web server using Ethernet or Ethernet over USB
- Setup via FieldCare/DeviceCare configuration software

 **Information on configuration using FieldCare/DeviceCare configuration software**

- Offline configuration: Most of the parameters are available (depending on the device configuration).
- Online configuration: Only parameters labeled "Online configuration" are available.  
→  84

### 9.4.1 Step-by-step: to the first measured value

#### Procedure and necessary settings:

1. Check the date/time in the main menu under "**Setup**" and set it if necessary.
2. Configure settings for the interfaces and communication in the main menu under "**Setup -> Advanced setup -> Communication**".
3. Create universal or digital inputs in the main menu under "**Setup -> Advanced setup -> Inputs -> Universal inputs/Digital inputs**": **Add input: select "Universal input x" or "Digital input x"** with which the input signal should be detected. Then select and configure the new input that has been created.
4. Activate relays or analog outputs (optional) in the main menu under "**Setup -> Advanced setup -> Outputs**".
5. Assign activated inputs to a group in the main menu under "**Setup -> Advanced setup -> Application -> Signal groups -> Group x**".
6. Use "Back" or "ESC" to quit the menu. The changes made are accepted and saved.

The device is in the measured value display mode and displays the measured values.

### 9.4.2 Step-by-step: setting or deleting the limit values

**Procedure for setting limit values:**

1. Open the limit values in the main menu under **"Setup -> Advanced setup -> Application -> Limits"**.
2. Add a limit value: select **"Yes"**.
3. Select and configure **"Limit value x"**.
4. Use "Back" or "ESC" to quit the menu. The changes made are accepted and saved.

The device is in the measured value display mode and displays the measured values.

**Procedure for deleting limit values:**

1. Open the limit values in the main menu under **"Setup -> Advanced setup -> Application -> Limits"**.
2. Delete a limit value: select **"Yes"**.
3. Select the limit value to be deleted from the list.
4. Use "Back" or "ESC" to quit the menu. The changes made are accepted and saved.

The device is in the measured value display mode and displays the measured values.

### 9.4.3 Device setup

You can open the main menu by pressing the navigator during operation. Turn the navigator to navigate through the available menus. When the desired menu is displayed, press the navigator to open the menu.

In the **"Setup"** menu and in the **"Advanced setup"** submenu, you will find the **most important** settings for the device:

Parameter	Possible settings	Description
Change date/time	UTC time zone dd.mm.yyyy hh:mm:ss	Change the date and time.
Advanced setup		Advanced settings for the device, such as system settings, inputs, outputs, communication, application etc.
	System	Basic settings that are needed to operate the device (e.g., date/time, security, memory management, messages, etc.)
	Inputs	Settings for the analog and digital inputs.
	Outputs	Settings only required if outputs (e.g., relays or analog outputs) are to be used.
	Communication	Settings required if the USB, RS232/RS485 or Ethernet interface of the device is to be used (PC operation, serial data export, modem operation, etc.).  The different interfaces (USB, RS232/RS485, Ethernet) can be operated in parallel. However, simultaneous use of the RS232 and RS485 interface is not possible.
	Application	Various application-specific settings (e.g., group settings, limit values etc.).

 For a detailed overview of all the operating parameters, please refer to the Appendix of the Operating Instructions. →  84

### 9.4.4 Setup via SD card or USB stick

An existing device configuration ("Setup data" \*.DEH) from another Ecograph T RSG35 or from FieldCare/DeviceCare can be uploaded directly to the device.

**Import new setup directly at the device:** The function used to load the setup data can be found in the main menu under **"Operation -> SD card (or USB stick) -> Load setup -> Select directory -> Next"**.

### 9.4.5 Setup via web server

To configure the device via the web server, connect the device to a PC via Ethernet (or Ethernet over USB).

Observe instructions and communication settings for Ethernet (or Ethernet over USB) and web server at →  31.

 To configure the device via a web server, you must have Administrator or Service access. ID and password administration is performed in the main menu under **"Setup -> Advanced setup -> Communication -> Ethernet -> Configuration Web server -> Authentication"**.

ID default value: admin; Password: admin

Note: Change the password during commissioning.

#### Establishing a connection and setup

##### Procedure for setting up a connection:

1. Connect the PC to the device via Ethernet (or Ethernet over USB).
2. Start the browser on the PC; enter the IP address: http://<IP address> to open the web server for the device. Note: Leading zeros in IP addresses must not be entered (e.g., enter 192.168.1.11 instead of 192.168.001.011).
3. Enter ID and password, and confirm each by clicking "OK" (see also the "Web server" section of the Operating Instructions →  42).
4. The web server shows the instantaneous value display of the device. In the web server taskbar, click **"Menu -> Setup -> Advanced setup"**.
5. Start parameter configuration.

Continue with device configuration in accordance with the Operating Instructions for the device. The complete Setup menu, i.e., all of the parameters listed in the Operating Instructions, can also be found on the web server. After configuration, accept the setup with **"Save settings"**.

 Procedure to establish a direct connection via Ethernet (point-to-point connection):  
→  41

#### NOTICE

##### Undefined switching of outputs and relays

- ▶ When configuring using a web server, the device may adopt undefined states. This may result in the undefined switching of outputs and relays.

 An existing device configuration ("Setup data" \*.DEH) from another Ecograph T RSG35 or from FieldCare/DeviceCare can be uploaded directly to the device via the web server.

##### Procedure for uploading a new setup via the web server:

1. Make the connection to the device with the web server →  36.
2. Click **"Data management -> Import device settings"** in the web server taskbar.
3. Select the setup file and press **"OK"** to confirm.

4. The file is transferred, checked and accepted.
5. Once the device settings are accepted, information to this effect is displayed in the web server.

### 9.4.6 Setup via FieldCare/DeviceCare configuration software

To configure the device using the configuration software, connect the device to a PC via USB or Ethernet.

 Download at: [www.endress.com/download](http://www.endress.com/download)

#### Establishing a connection and setup

Continue with device configuration in accordance with the Operating Instructions for the device.

The complete Setup menu, i.e. all the parameters listed in the Operating Instructions, can also be found in the configuration software.

#### NOTICE

#### Undefined switching of outputs and relays

- ▶ During configuration using the configuration software, the device may assume undefined states. This may result in the undefined switching of outputs and relays.



## 9.5 Advanced settings (Expert menu)

You can open the main menu by pressing the navigator during operation. Turn the navigator to navigate to the **"Expert"** menu. Press the navigator to open the menu.

 The Expert menu is protected by the code **"0000"**. If an access code is set up under **"Setup -> Advanced setup -> System -> Security -> Protected by -> Access code"**, this must be entered here.

The **"Expert"** menu contains **all** of the device settings:

Parameter	Possible settings	Description
Direct access	000000-000	Direct access to parameters (fast access)
System		Basic settings that are needed to operate the device (e.g., date/time, security, memory management, messages, etc.)
Inputs		Settings for the analog and digital inputs.
Outputs		Settings only required if outputs (e.g., relays or analog outputs) are to be used.
Communication		Settings required if the USB, RS232/RS485 or Ethernet interface of the device is to be used (PC operation, serial data export, modem operation, etc.).  The different interfaces (USB, RS232/RS485, Ethernet) can be operated in parallel. However, simultaneous use of the RS232 and RS485 interface is not possible.
Application		Define various application-specific settings (e.g., group settings, limit values etc.).
Diagnostics		Device information and service functions for a quick device check.

 A detailed overview of all the operating parameters is provided in the appendix at the end of the Operating Instructions. →  84

## 9.6 Configuration management

**i** You can save the setup data ("Configuration") to an SD card or a USB stick, to a PC drive via the web server, and store them in a database using the configuration software. This allows additional devices to be configured very easily using the same settings.

**Save setup:** The function used to save the setup files can be found in the main menu under **"Operation -> SD card (or USB stick) -> Save setup"**.

### **CAUTION**

**If the SD card or USB stick is removed directly:**

Risk of data loss on SD card or USB stick

- ▶ To remove the SD card or the USB stick, always select **"Operation -> SD card (or USB stick) -> Remove safely"** in the main menu.

**Procedure for saving a setup via the web server:**

1. Make the connection to the device with the web server. → 36
2. Click **"Data management -> Save device settings"** in the web server taskbar.
3. Select the setup file.
4. Transfer the file.
5. Verify and accept.
6. Once the device settings are accepted, information to this effect is displayed in the web server.

**i** The function for saving the setup data must be enabled at the device for the web server under **"Setup -> Advanced setup -> Communication -> Ethernet -> Configuration Web server; Setup -> Yes"**.

## 9.7 Simulation

Various functions/signals can be simulated for test purposes here.

### **NOTICE**

**Selecting simulation: Simulation of the relays and the WebDAV client can be found in the main menu under "Diagnostics -> Simulation". The simulation of the measured values can be found in the main menu under "Expert -> Diagnostics -> Simulation".** Only the simulated values are recorded during simulation. The simulation is recorded in the event logbook.

- ▶ Do not start simulation if measured value recording must not be interrupted.

## 9.8 Access protection and security concept

To protect the setup from unauthorized access following commissioning, there are many options to ensure access protection to the setup settings and the user entries. Access and authorizations can be configured and assigned passwords.

**i** The user of the device is responsible for access protection and the security concept. In addition to the device functions listed, user policies and procedures, in particular, must also be applied (e.g., password allocation, password sharing, physical access barriers, etc.).

The following protection options and functionalities are available:

- Protection per control input
- Protection via access code
- Protection via user roles

### Overview of access protection and security concept

Access protection	User	Setup changes	Description
Open access	-	Permitted	No protection, not recommended, all setup and system settings are accessible.
Control input	-	Permitted	Access protection via digital input (e.g., via key switch), all setup and system settings are accessible if input actuated.
Access code	-	Permitted	Access protection via access code, access authorization (distribution of access code) must be defined via (in-house) regulations and securely controlled. All setup and system settings can be accessed after entering the access code.
Password-protected user roles			Protection levels and access authorization can be defined via 3 levels of access (user roles). Access authorization (distribution of passwords) must be defined via (in-house) regulations and securely controlled.
	Administrator	Permitted	Access protection via administrator password, all setup and system settings can be accessed after entering the password.
	Service	Permitted	Access protection via service password, all setup and system settings can be accessed after entering the password, advanced functions (e.g., preset) are possible in the service mode
	Operator	Locked	All setup and system settings are locked, access to device information and display values after entering the password.

In order to change any parameter, the correct code must first be entered or the device must be unlocked using the control input.

**Setup lock via control input:** The settings for the control input can be found in the main menu under "**Setup -> Advanced setup -> Inputs -> Digital inputs -> Digital input X -> Function: Control input; Action: Lock setup**".

 It is preferable to lock the setup using a control input.

**Setting up an access code:** The settings for the access code can be found in the main menu under "**Setup -> Advanced setup -> System -> Security -> Protected by -> Access code**". Factory setting: "open access", i.e. can be changed at any time.

 Make a note of the code and store in a safe place.

**Setting up user roles:** The settings for the user roles (operator, admin and service) are provided in the main menu under "**Setup -> Advanced setup -> System -> Security -> Protected by -> User roles**". Factory setting: "open access", i.e. can be changed at any time.

 Change the passwords during commissioning.

Make a note of the code and store in a safe place.

## 9.9 HTTPS web server setup

To operate the HTTPS web server, an X.509 certificate and a suitable private key must be installed on the device. For security reasons, installation is via a USB stick only.

 The certificate that is preinstalled on the device when delivered from the factory should not be used.

 Server certificates cannot be installed via the "USB stick/import SSL certificates" function!

## Requirements

Private key:

- X.509 PEM file (Base64 encoded)
- RSA key with max. 2048 bit
- May not be password-protected

Certificate:

- X.509 file (Base64 encoded PEM or binary DER format)
- V3 incl. extension required
- Signed by a certification authority (CA) or sub-certification authorities (recommended), or self-signed

Certificate and private key can be created or converted using openssl (<https://www.openssl.org>) for example. Contact the IT administrator to create the corresponding data.



Tip: More information on this topic is provided in our How To Videos <https://www.youtube.com/endresshauser>

Installation:

1. Copy the private key onto a USB stick into the root directory. File name: **key.pem**.
2. Copy the certificate onto a USB stick into the root directory. File name: **cert.pem** or **cert.der**.
3. Connect the USB stick to the device. The private key and the certificate are installed automatically. The installation is logged in the event logbook.
4. Remove the USB stick using the "**Safe removal**" function.



### Notes:

- Restart the device so the browser uses the new certificate.
- Delete the private key from the USB stick following installation.
- Keep the private key in a safe place.
- Use the private key and the certificate for one device only.
- To prevent unauthorized use, it is possible to disable the USB A port on the device. In this way, an attacker cannot replace the certificate or the private key ("Denial of Service"). Install a perimeter guard to prevent access to the device.

## Checking certificates

Check the certificate via "**Main menu -> Diagnostics -> Device information -> SSL certificates**". Select the "**Server certificate**" point under the certificate.



Replace the certificate in good time before it expires. The device will display a diagnostic message 14 days before the certificate expires.

## Uninstalling certificates and the private key

Check the certificate via "**Main menu -> Diagnostics -> Device information -> SSL certificates**". Select the "**Server certificate**" point under the certificate. Delete the certificate.



In this case, the preinstalled certificate is reused.

## Using self-signed certificates



Self-signed certificates must be stored in the PC's certificate memory under "Trusted Root Certification Authorities" so that the browser does not display a warning.

Alternatively, an exception can be saved in the browser.

## 10 Operation

The "Operation" menu is geared towards the tasks and activities of the operator. It contains all the parameters that are needed in ongoing operation. Historical values and analyses, for example, can be displayed in the "Operation" menu and display settings can be made. Any settings made for the local display have no effect on the measurement section or the configured device parameters, however.

The device's simple operating concept and the integrated help function enables you to perform operation for many applications without the need for hard-copy operating instructions.

### 10.1 Displaying and modifying current Ethernet settings

To establish communication with the device via Ethernet, the following settings must be known and modified where necessary:

**Display IP/MAC address** (only if DHCP is enabled): For the device's IP and MAC address, see the main menu under "**Diagnostics -> Device information -> Ethernet**".

**Display/change Ethernet settings**: For the device's Ethernet settings, see the main menu under "**Setup -> Advanced setup -> Communication -> Ethernet**".

**Procedure to establish a direct connection via Ethernet (point-to-point connection):**

1. Configure the PC (depends on operating system): e.g., IP address: 192.168.1.1; subnet mask: 255.255.255.0; gateway: 192.168.1.1
2. Disable DHCP on the device.
3. Specify the communication settings on the device: e.g., IP address: 192.168.1.2; subnet mask: 255.255.255.0; gateway: 192.168.1.1



A crossover cable is not required.

### 10.2 Reading off the device locking status

If setup is locked via a control input, a padlock symbol  appears on the top right of the screen. The setup must first be unlocked via the control input before device parameters can be edited.

**Setup lock via control input**: For the settings for the control input, see the main menu under "**Setup -> Advanced setup -> Inputs -> Digital inputs -> Digital input X -> Function: Control input; Action: Lock setup**".

If setup is locked via the access code, all the operating parameters can be displayed, and can also be edited as soon as the access code is entered.

### 10.3 Reading off measured values (display devices)

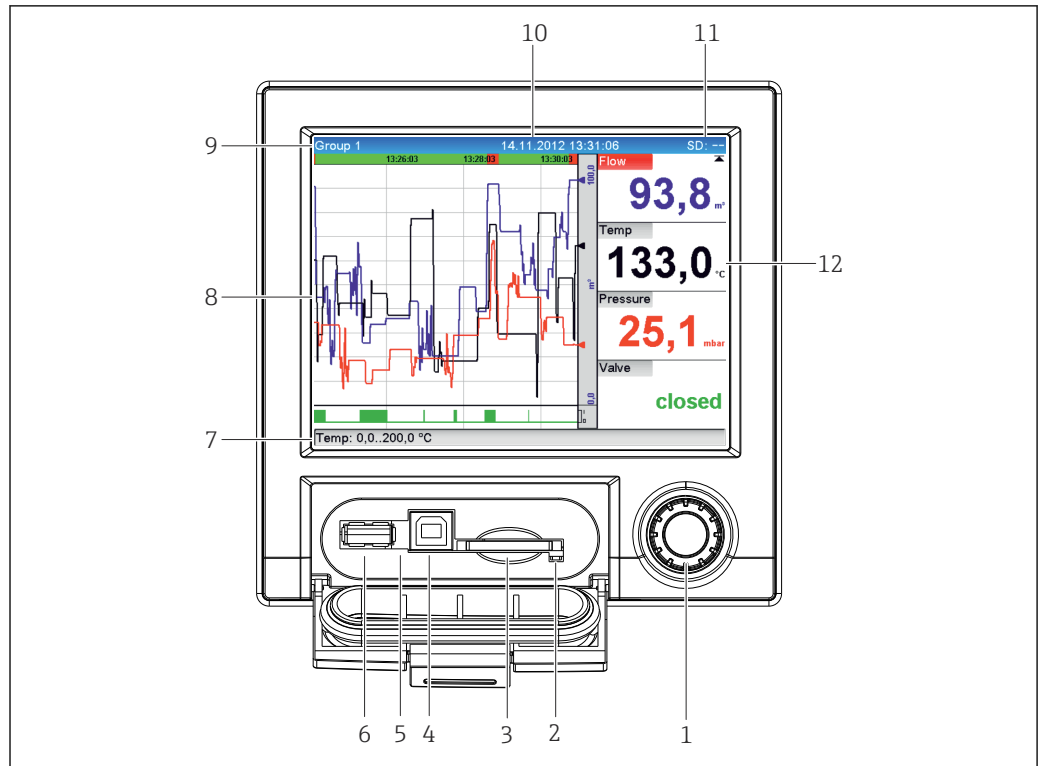

A0047011

7 Front of device with open flap

- 1 Navigator: press briefly to open the main menu and confirm messages (=Enter); press for longer to open the online help
- 2 Orange LED for read/write access to the SD card
- 3 Slot for SD card
- 4 USB-B socket "Function"
- 5 Green LED lit: power supply present
- 6 USB-A socket "Host"
- 7 Status bar
- 8 Area for measured value display (e.g., curve display)
- 9 Header: group name, analysis type
- 10 Header: current date/time
- 11 Header: alternating display indicating the percentage space on the SD card or USB stick that has already been used. Status symbols are also displayed in alternation with the memory information.
- 12 Display of current measured values and the status in the event of an error/alarm condition. In the case of counters, the type of counter is displayed as a symbol.

**i** An overview of all the symbols and icons is provided in the "Operation options" section. → 27

**i** If a measuring point has limit value status, the corresponding channel identifier is highlighted in red (quick detection of limit value violations). During a limit value violation and device operation, the acquisition of measured values continues uninterrupted.

**i** Information on how to rectify a problem if an error occurs is provided in the "Troubleshooting" section. → 56

### 10.4 Web server

The device features an integrated web server, which enables access via Ethernet (or Ethernet over USB). The web server is used for convenient device commissioning and configuration and to visualize measured values. Access is possible from any access point when the device is connected to an Ethernet network. An appropriate IT infrastructure,

security measures etc. must be implemented in accordance with the requirements of the plant. Point-to-point access via web server and Ethernet via USB is particularly well-suited for service purposes.

Activation of the web server in the menu **Setup** → **Advanced setup** → **Communication** → **Ethernet** → **Web server** → **Yes** or menu **Expert** → **Communication** → **Ethernet** → **Web server** → **Yes**

The web server port is preset to 80. The port can be changed in the **Expert** → **Communication** → **Ethernet** menu.

 If the network is protected by a firewall, the port may need to be activated.

The following web browsers are supported:

- MS Internet Explorer 11 and higher
- MS Edge
- Mozilla Firefox 52.1.0 and higher
- Opera 12.x and higher
- Google Chrome 66 and higher

 A minimum resolution of 1920x1080 (full HD) is recommended.

In order to use the full functionality of the web server, it is recommended that the latest version of the browser is used. To access the device via a web server, you must have Administrator, Service or Operator authentication →  38

 The web server is not optimized for visualization on smartphones.

When delivered, the following default values are set for the user roles in the device and web server:

- ID: admin; password: admin
- ID: service; password: service
- ID: operator; password: operator

 Note: Passwords should be changed during commissioning!

The ID and password can be changed in the main menu under "**Setup** → **Advanced setup** → **Communication** → **Ethernet** → **Configuration Web server** → **Authentication**".

#### 10.4.1 Access to the web server via HTTP (HTML)

When using an Internet browser, it is enough to enter the address **http://<IP address>** to display the information as HTML in the browser.

 Note: Leading zeros in IP addresses must not be entered (e.g., enter 192.168.1.11 instead of 192.168.001.011).

As in the case of the display, you can alternate between the display groups in the web server. The measured values are automatically updated. In addition to the measured values, status and limit value flags are displayed.

#### 10.4.2 Access to the web server via XML

XML format is available in addition to HTML format and contains all measured values of a group. This can be integrated into additional systems as the user wishes.

The XML file is available in ISO-8859-1 (Latin-1) coding at **http://<IP address>/values.xml** (alternative: **http://<IP address>/xml**). However, some special characters,

such as the Euro symbol, cannot be displayed in this file. Texts, such as digital status, are not transmitted.

**i** Note: Leading zeros in IP addresses must not be entered (e.g., enter 192.168.1.11 instead of 192.168.001.011).

**i** The decimal separator is always displayed as a period in the XML file. All times are given in UTC. The time difference in minutes is noted in the following entry.

The structure of the channel values for the XML file is explained as follows:

```
<device      id="AI01IV" tag="Channel 1" type="INTRN">
              <v1>50.0</v1>
              <u1>%</u1>
              <vtime>20130506-140903</vtime>
              <vstslv1>0</vstslv1>
              <hlsts1>L</hlsts1>
              <param><min>0.0</min><max>100.0</max><hh></hh><hi></hi><lo></lo><ll></ll></
              param>
              <tag>Channel 1</tag>
              <man>Manufacturer</man>
</device>
```

Tag	Description
device id	Unique ID of measuring point
tag	Channel identifier
type	Data type (INTRN, MODBUS)
v1	Measured value of channel as a decimal value
u1	Unit of measured value
vtime	Date and time
vstslv1	Error level 0 = OK, 1 = warning, 2 = error
hlsts1	Limit value status H = upper limit value, L = lower limit value, LH = upper and lower limit value violation
param	Parameter (optional)
min	Lower zoom
max	Upper zoom
hh	Upper alarm limit
hi	Upper warning limit
lo	Lower warning limit
ll	Lower alarm limit
MAN	Manufacturer

### 10.4.3 Setup, operation and service via the web server

#### Establishing a connection to the web server:

1. Connect the PC to the device via Ethernet (or Ethernet over USB)
2. Start the browser on the PC
3. Enter the device's IP address in the browser **http://<ip address>**
4. Log in with the ID and password

The startup screen of the web server appears.

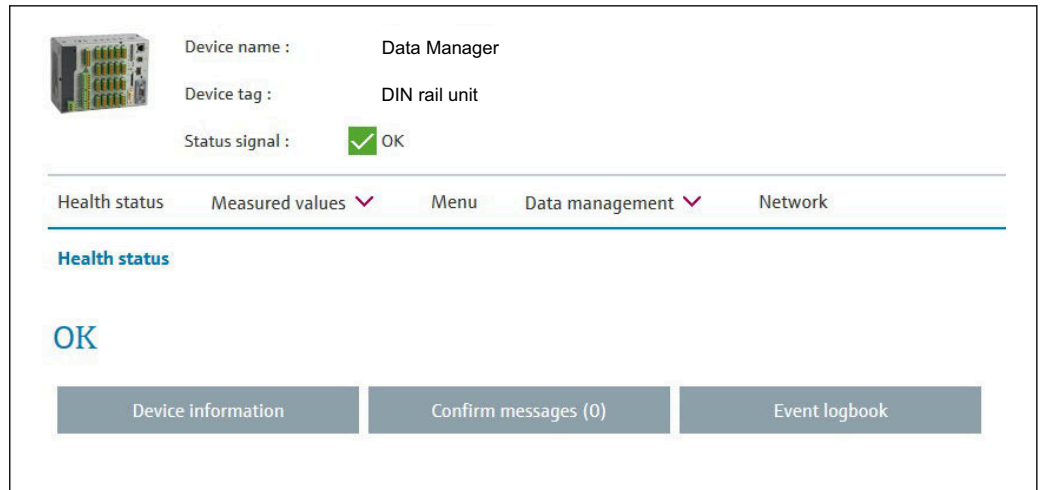

A0037114

General information regarding the **Device name**, **Device tag** and **Status signal** is displayed in the top section of the web server. The following functions can be accessed in the middle of the screen:

**Health status – Measured values – Menu – Data management - Network.**

Clicking the functions calls up the following submenus. The submenus are closed by selecting "Cancel" or by clicking "Back" several times.

**Health status (advanced device status)**

Function	Description
Device information	Advanced device status, Ethernet settings, hardware configuration, device options, memory information, SSL certificate
Confirm messages	Submenu to confirm system messages
Event logbook	Submenu for the event logbook

**Measured values (choice of measured value display)**

Function	Description
Instantaneous values	Measured values are displayed as numerical instantaneous values, the signal groups can be selected as tabs here
Instantaneous values as curves	The measured values are displayed as curves
History	Displays a history of the measured values

**Menu**

The menu structure displayed in the web server corresponds largely to the menu structure in the device

**Data management**

Update functions and parameters relating to the firmware, load/save setup, save setup as RTF, import SSL certificates

**Network**

Displays the Ethernet parameters (IP address, subnet mask, gateway, domain)

**Displays the current measured values and history data**

Under **Measured values** a selection window appears for **Instantaneous values – Instantaneous values as curves – History**. Click to display the corresponding display function.

 Current measured values can also be called up via the web server without logging in with the address **http://<IP address>/iv**. Device configuration is **not** possible in this case, however.

Note: The browser must support HTML5.

Optional command parameters:

- Syntax: `http://<ip address>/iv?group=<x>&refresh=<y>`
- `group=<x>` where `x = 1 to 4`
- `refresh=<y>` where `y = 3 to 3600` in seconds

Note: Pay attention to lower and upper case if using an optional parameter.

This function can be disabled in the setup. If this function is disabled, the option to export instantaneous values to XML is also disabled for security reasons.

**Instantaneous values**

The current measured values are displayed in numerical format. Clicking the tabs displays the signal groups defined in the setup.

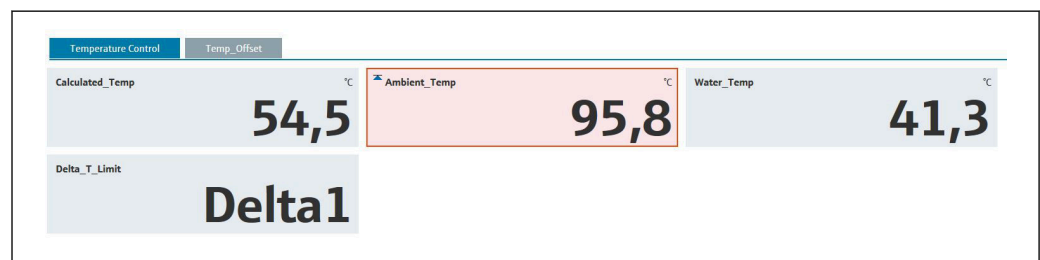

A0037118

**Instantaneous values as curves**

The current measured values are displayed as a curve and numerically over the time axis. The refresh rate can be set in a selection window. The display mode can be set to full screen. Clicking the tabs displays the signal groups defined in the setup.

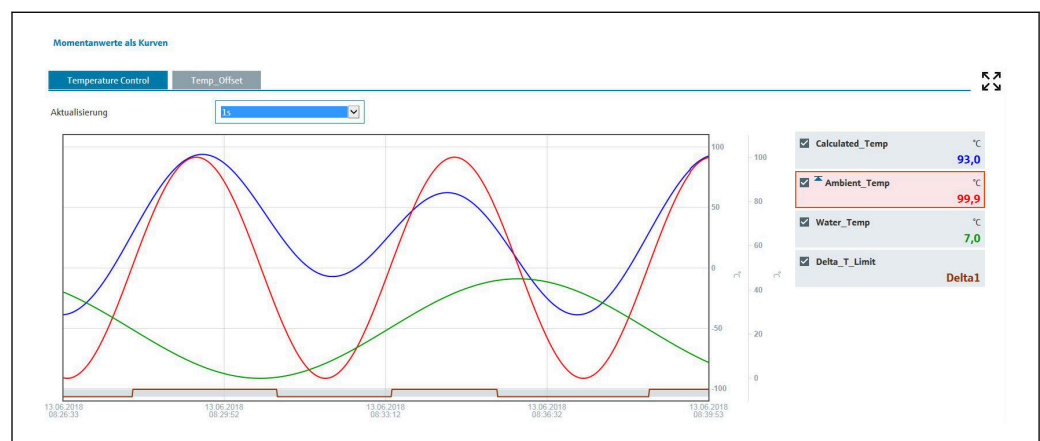

A0037117

**Display functions**

If the cursor is moved over one of the curves, the instantaneous value of the current point in the curve is displayed with the timestamp and unit. Channels can be displayed and hidden using the channel checkboxes in the legend.

### History (logged measured values)

Clicking the **History** button loads the data previously logged. This may take a few seconds depending on the data connection (USB, Ethernet, WLAN) and the number of measuring channels. The data for each channel is loaded to display the content of one screen. The logged (history) measured values are displayed as a curve and numerically over the time axis. The display mode can be set to full screen. Clicking the tabs displays the signal groups defined in the setup.

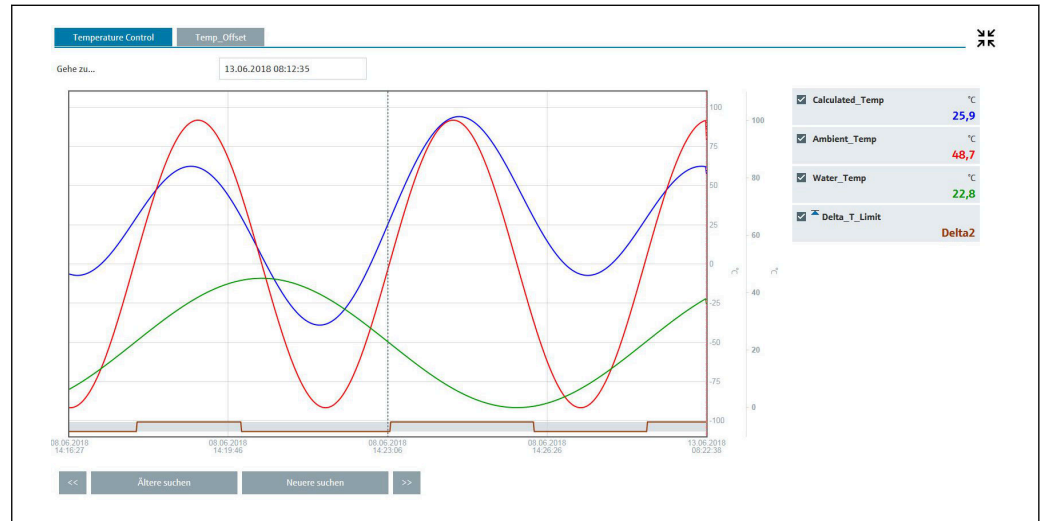

A0037115

### Display functions

If the cursor is moved over one of the curves, the instantaneous value of the current point in the curve is displayed with the timestamp and unit. Channels can be displayed and hidden using the channel checkboxes in the legend.

Moving the dashed cursor line along the time axis updates the numerical display of the measured values accordingly (on right).

**Go to ...:** Enter a point in time. The history is reloaded. If you enter a time for which no measured values are available, the next possible time where measured values are available is displayed.

**Search older:** The information displayed moves half a screen to the left (displays older measured values). Press the << button to move the information one entire screen to the left (older measured values).

**Search newer:** The information displayed moves half a screen to the right (displays more recent measured values). Press the >> button to shift the information one entire screen to the right (more recent measured values).

**Note:** If no measured values were recorded for a certain range of time (e.g., as there was no power supply), this is indicated by a symbol at the top of the window. The curves jump accordingly.

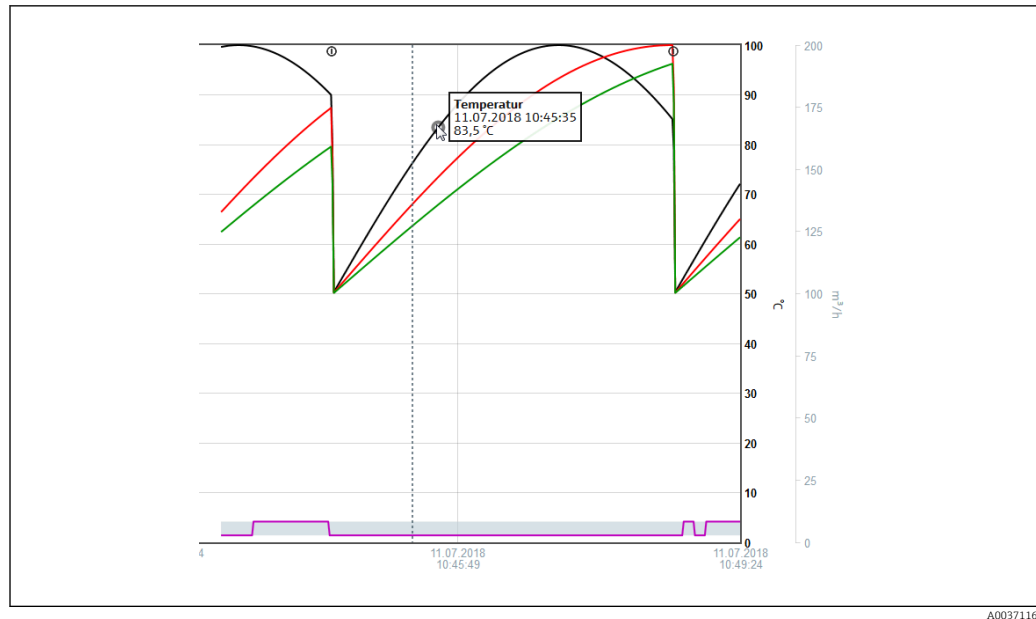

#### 10.4.4 Remote control via the web server

The device can be remote-controlled via the web server. In the web server, the remote control function can be found under **"Measured values -> Remote control"**. Here the display shown corresponds directly to the device display. The device is operated using buttons below this display. The interval for refreshing the display can be set in the **"Refresh"** menu.

**Enabling remote control on the device:**

1. In the menu **Setup -> Advanced setup -> Communication -> Ethernet -> Configuration Web server -> Remote control**, select **"Yes"** or under
2. **Expert -> Communication -> Ethernet -> Configuration Web server -> Remote control**, select **"Yes"**.

### 10.5 Changing group

The group to be displayed can be changed in the main menu under **"Operation -> Change group"**. Alternatively, the group can also be changed by turning the navigator.

- i** Only the **active** groups are displayed here. The settings for this can be made in the main menu under **"Setup -> Advanced setup -> Application -> Signal groups -> Group x"**.



### 10.6 Locking operation

Local operation can be blocked in the main menu under **"Operation -> Lock operation"** to prevent unintended or incorrect operation (e.g., when cleaning the device).

- i** The device is unlocked by pressing the navigator or the OK operating key for 3 s. When using an external keyboard, the device is unlocked with the key combination **"Ctrl-Alt-Del"**.

## 10.7 Logging in/logging out

Log onto the device or log off the user currently logged on.

 Only for role-based access protection →  38

## 10.8 SD card/USB stick



### 10.8.1 Operating principle of SD card and USB stick

Without affecting the internal memory, data packets are copied block by block (min. 1 x daily, midnight) to the SD card. Once a new SD card is inserted, the device starts saving the data automatically after 5 minutes. The use of a USB stick is only recommended if certain data ranges should be copied.

The USB stick is **not** used for the continuous storage of measured values, i.e. it is **not** updated automatically.

Data are saved in two different folders on the storage media depending on the storage method:

- All data are copied cyclically to the **rec\_data\_<Device name>** folder if a data packet is complete or the function **"Update"** is activated under **"Operation -> SD card/USB stick -> Update"**.
- The data for the selected time range that was selected under **"Operation -> SD card / USB stick -> Save measured value"** are copied to the **rng\_data\_<device name>** folder. Copying these data does not affect the storage of the data in the **rec\_data\_<device name>** folder.

- 
  - Only use new, formatted SD cards that are recommended by the manufacturer (see "Accessories" →  66).
  - During normal operation, the used memory space on the SD card or USB stick is displayed on the top right of the display ("SD: xx%" or "USB: xx%"). Dashes "-" on this display mean that no SD card is inserted.
  - The SD card must not be write-protected.
  - Prior to removing the external data carrier, select **"Operation -> SD card/USB stick -> Update"**. The current data block is closed and saved to the external data carrier. This ensures that all the current data (up until the last save) is included on the data carrier.
  - Depending on the device configuration (see **"Setup -> Advanced setup -> System -> Ext. memory -> Warning at"**), an acknowledgeable message on the display notifies the user that the external data carrier has to be changed before the data carrier is 100% full.
  - The device keeps track of which data have already been copied onto the SD card or USB stick. If the data carrier is not changed in time or if no SD card is inserted, the new external data carrier is filled with the missing data from the internal memory - insofar as the data are still in the memory. As measured value acquisition/recording is assigned the highest priority, it may take several minutes in this case for the data to be copied from the internal memory to the SD card or USB stick.

### 10.8.2 Functions relating to the SD card or USB stick

For functions to save measured data and device settings on a removable medium, see the main menu under **"Operation -> SD card / USB stick"** (only if an SD card or USB stick is provided).

#### Remove safely:

All internal access is terminated to ensure safe removal of the storage medium from the device. A message is displayed when the storage media can be removed. If the SD card is

not removed, the device automatically starts to save data to the storage medium again after 5 minutes.

 Only remove the data storage medium using this function; otherwise, data may be lost!

**Update:**

Measurement data not yet saved on the storage medium are now saved. This may take a moment. Measured value acquisition is running in parallel and has top priority.

 Data from several devices can be saved onto one storage medium.

▪ **Save measured values:**

A user-definable time range can be saved on the data storage medium.

▪ **Load setup:**

Loads device settings (setup) from the storage medium onto the device.

▪ **Save setup:**

All device settings (setup) are saved onto the storage medium. They can be archived or used for other devices.

▪ **Save setup as RTF:**

Saves the setup on the storage medium in a readable format as an RTF file (rich text format).

The RTF file can be opened and formatted using suitable word processing software (e.g., MS Word), making it easy to print.

▪ **Screenshot:**

Save the current measured value display as a bitmap on the SD card or USB stick.

▪ **Update firmware:**

Loads new firmware onto the device. Only visible if a firmware file is provided on the SD card or USB stick.

 Caution: The device will restart. Save the setup and measured values beforehand on the SD card or USB stick.

**Import SSL certificate:**

Uploads an SSL certificate (X.509) to the device. Certificates are needed so that an SSL connection can be established in order to send encrypted e-mails, for instance. Certificates are available from your network administrator or provider. The following are supported: DER, CER and CRT (binary or Base64-encoded).

Only visible if an SSL certificate is provided on the SD card or USB stick.

### 10.8.3 Notes on e-mail encryption

In addition to sending unencrypted e-mails, it is also possible to send encrypted e-mails via SSL (TLS). To do so, you can choose either of two ways:

▪ By **SMTPTS**: fully encrypted via port 465.

The complete connection runs over TLS. The port is 465 by default but this value can be changed in the Setup.

▪ Via port 25 or 587 using **STARTTLS**.

With this method the device first establishes a plain SMTP connection via port 25 and continues this connection following agreement and switchover to encryption.

The required process can be selected as follows: "**Setup -> Advanced setup -> Application -> E-mail -> Server requires SSL**" or under "**Expert -> Application -> E-mail -> Server requires SSL**".

TLS V1.0 (=SSL 3.1), V1.1 and V1.2 are supported. Older standards are not supported. The encryption method is automatically agreed with the counterparty.

A certificate must be installed in order to be able to send encrypted e-mails. These certificates can be obtained from your e-mail service provider. The following file formats are supported:

- \*.CER: DER- or Base64-encoded certificate
- \*.CRT: DER- or Base64-encoded certificate
- \*.DER: DER-encoded certificate

 The file name of the certificate may only contain the following characters: a-z, A-Z, 0-9, +, -, \_, #, (, ), !

To establish an SSL connection, the device automatically selects the certificate that best suits the counterparty from all the installed certificates. An error message is displayed if the device does not have any of the required certificates.

 When e-mail encryption is enabled, no e-mails can be sent if a valid certificate is not available or if the certificate has expired.

#### 10.8.4 Notes on WebDAV encryption

In addition to sending unencrypted data to the WebDAV server, it is also possible to send encrypted data via SSL (TLS). All data are sent in encrypted format via the SSL port of the external WebDAV server.

The complete connection runs over TLS. The port is 80 by default but this value can be changed in the Setup. The procedure to be used can be selected as follows: **"Setup -> Advanced setup -> Application -> WebDAV Client -> Enable -> Yes (SSL)"** or under **"Expert -> Application -> WebDAV Client -> Enable -> Yes (SSL)"**.

TLS V1.0 (=SSL 3.1), V1.1 and V1.2 are supported. Older standards are not supported. The encryption method is automatically agreed with the counterparty.

A certificate must be installed in order to be able to send encrypted data. These certificates can be obtained from your WebDAV server service provider. The following file formats are supported:

- \*.CER: DER- or Base64-encoded certificate
- \*.CRT: DER- or Base64-encoded certificate
- \*.DER: DER-encoded certificate

 The file name of the certificate may only contain the following characters: a-z, A-Z, 0-9, +, -, \_, #, (, ), !

To establish an SSL connection, the device automatically selects the certificate that best suits the counterparty from all the installed certificates. An error message is displayed if the device does not have any of the required certificates.

 When WebDAV client encryption is enabled, no data can be sent if a valid certificate is not available or if the certificate has expired.

#### 10.8.5 SSL certificates

##### Importing an SSL certificate

Installing a certificate via SD card or USB stick:

1. Copy a certificate on a PC to an SD card or USB stick
2. Insert the SD card or USB stick into the device
3. In the main menu, select **"Operation -> SD card (or USB stick) -> Import SSL certificate"**
4. Select the required certificate from the list and follow the dialog on the display.

Installing a certificate via the web server:

1. On the web server, select **"Data management --> Import SSL certificate"**

2. Select the file
3. Start the process by clicking **OK**

 Up to 3 certificates can be installed simultaneously.

### Verifying the installed SSL certificates

The installed certificates can be verified in the main menu under **"Diagnostics -> Device information -> SSL certificates"**. The parameter list displays the most important certificate information, such as the key identifier, organization, and validity period.

 Not all fields are completed on all the certificates. This is because the parties issuing the certificates do not make all the information available.

### Deleting an SSL certificate

In the main menu select the certificate to be deleted under **"Diagnostics -> Device information -> SSL certificate -> Certificate"** and select **"Yes"** under **"Delete certificate"**.



### Period of validity of certificates

Certificates are valid for a defined period (valid from ... to ...). The device checks the certificate validity once a day or each time the device is rebooted. 14 days before the certificate expires the device notifies the user daily (by e-mail, screen display, entry in event logbook) that the certificate will expire shortly.

If the certificate has expired the alarm relay switches (if activated) and a message is displayed on the screen. An entry is also made in the event logbook. If a certificate is deleted all errors related to this certificate are reset.

## 10.9 Show data logging

You can scroll through the saved measured values in the main menu under **"Operation -> History"**. Turn the navigator clockwise or counterclockwise to scroll back and forth between the measured value curves. Press the navigator to configure other settings for historical data (e.g., change the scroll speed, time scaling or display mode) and end display of historical data.

 The gray header on the screen and the  symbol in the status bar indicate that historical values are being displayed. In the instantaneous value display the color of the header is blue.

### 10.9.1 Historical data: Change group

It is possible to change the group to be displayed in the historical data under **"Operation -> Change group"** in the data history.

### 10.9.2 Historical data: scroll speed

Specify how fast the display should scroll when the navigator is turned.

It is possible to change the scroll speed in the historical data under **"Operation -> Scroll speed"** in the data history.

The scroll speed can also be set via the soft key with the arrow symbol < or >. The speed can be changed from < (slow) to <<<< (fast) by pressing the soft key repeatedly.

### 10.9.3 Historical data: Time scaling

It is possible to scale the displayed time range in the historical data under "**Operation -> Time scaling**" in the data history.



Notes:

- "1:1" option: Every measured value is displayed.
- "1:n" option: Only every nth measured value is displayed (increases the displayed time range).
- No interpolation is performed, nor is the mean value determined.
- If the value for "n" is large, this can result in extended loading times.
- Time scaling does not affect the process for storing the measured value.
- The time range displayed per screen for the currently set time scaling is also displayed in the menu.

### 10.9.4 Historical data: Time range displayed

The displayed time range is shown in the historical data under "**Operation -> Time range displayed**" in the data history. This tells the user which time range is displayed per screen in the standard memory cycle.



If the alarm cycle differs from the standard memory cycle, this is not taken into consideration.

### 10.9.5 Historical data: Screenshot

The current measured value display can be saved as a bitmap to an SD card or USB stick in the historical data under "**Operation -> Screenshot**".

### 10.9.6 Historical data: Change the display mode

It is possible to change the display mode of the active group in the historical data under "**Operation -> Change display mode**" in the data history.

The following display modes are possible: Curve, Curve in ranges, Waterfall, Waterfall in ranges.



The various display modes have no influence on the signal recording.

## 10.10 Signal analysis

The analyses saved in the device are displayed in the main menu under "**Operation -> Signal analysis**".

- **Actual intermediate analysis:**  
The current (i.e. not yet completed) intermediate analysis can be displayed here.
- **Actual day:**  
The current (i.e. not yet completed) daily analysis can be displayed here.
- **Actual month:**  
The current (i.e. not yet completed) monthly analysis can be displayed here.
- **Actual year:**  
The current (i.e. not yet completed) annual analysis can be displayed here.
- **Search:**  
Search and display of analyses. Select which analyses the system should search for/  
display: Intermediate analysis, Daily analysis, Monthly analysis, Annual analysis.

## 10.11 Search in trace

In the main menu, the internal memory can be searched for events or times under **"Operation -> Search in trace"**.

**Search for events:** The event logbook forms the basis for searches for events. To make it easier to search for specific events (e.g., setup changes), you can use the search filter to select and search for the desired events. In the standard all events are shown. In the event list displayed, it is possible to select an event and go directly to this point in the history (if still in the memory).

**Search for time:** When searching for a time in the past, the user can enter a date and a time to specify when the system should start displaying historical data. Once the date/time have been entered and confirmed, the display goes to the selected time in the active group.

## 10.12 Changing the display mode

The display mode of the active group can be changed in the main menu under **"Operation -> Change display mode"**.

The following display modes are possible: Curve, Curve in ranges, Waterfall, Waterfall in ranges, Bargraph and Digital display.

 The various display modes have no influence on the signal recording.

## 10.13 Adjusting the brightness of the display

You can adjust the brightness of the display in the main menu under **"Operation -> Adjust brightness"**:

Parameter	Possible settings	Description
Adjust brightness	0-100 Default: <b>80</b>	Sets the brightness of the display

## 10.14 Limit values

It is possible to change the limit values during operation in the main menu under **"Operation -> Limits"**.

 This function must be enabled beforehand in the main menu under **"Expert -> Application -> Limits -> Change limits: outside of setup also"**.

Detailed description of the limit values: →  155

## 10.15 WebDAV client

The function of the WebDAV client is to transmit recorded data automatically to a connected WebDAV server (e.g., NAS drive). The recorded data are sent to the connected WebDAV server cyclically every 15 minutes. The generated files correspond to the files that are automatically saved to the SD card.

The client is configured via **"Setup -> Advanced setup -> Application -> WebDAV Client"**. The settings under **"Setup -> Advanced setup -> System -> External memory"** are also used, with the exception of the settings for the SD card (Memory build-up, Warning and Relays). The memory is regarded as a stack memory.

Detailed description of the parameters: →  171

 Note: With the WebDAV client, the data are transmitted to the WebDAV server in accordance with the selection made in the .CSV or "Protected format".

### 10.15.1 Access to the WebDAV server via HTTP (HTML)

Address entry in browser: **http://<ip-address>/webdav**

The data are updated cyclically every 15 minutes. The data are automatically updated each time a user logs in.

 Note: Leading zeros in IP addresses must not be entered (e.g., enter 192.168.1.11 instead of 192.168.001.011).

 Administrator or service authentication is required. ID and password administration is performed in the main menu under **"Setup -> Advanced setup -> Communication -> Ethernet -> Configuration Web server -> Authentication"**.

ID default value: admin; Password: admin

Note: The password must be changed during commissioning.

Note: For devices with a stainless steel front and touchscreen, the data are always made available in "Protected format" via the WebDAV server.

## 10.16 Data analysis and visualization with the Field Data Manager software (FDM)

The analysis software offers centralized data management with visualization for recorded data.

This enables the data of a measuring point to be fully archived, e.g.:

- Measured values
- Diagnostic events
- Protocols

The analysis software stores data in an SQL database. The database can be operated locally or in a network (client/server). A free version of the Postgre<sup>TM</sup>SQL database can be enabled when FDM is installed.

 For details, see the online help in the analysis software and the Operating Instructions for the analysis software.

### 10.16.1 Structure/layout of a CSV file

The CSV files are comprised as follows:

File name (=serial number + file number + configuration number + date and start time + data type)	Description	Coding
H4000504428 0000000279 0000000185 2013-11-07 11-18-00 GROUP01.csv	Contains all the measured values of the group from the starting time indicated in the file name. An individual CSV file is created for each group.	ANSI
H4000504428 0000000279 0000000185 2013-11-07 11-30-00 ANALYSIS01.csv	Contains the signal analyses of the active channels from the starting time indicated in the file name. An individual CSV file is created for every analysis (01 - 04).	ANSI
H4000504428 0000000279 2013-11-07 11-18-34 EVENTS.csv	Contains the event logbook from the starting time indicated in the file name.	Unicode UTF-8 (see the notes in the following section)

*Meaning of the values under "Status" and "Limit" when analyzing a group:*

**Status of the channel:**

0: OK

1: Cable open circuit

**Status of the channel:**

- 2: Input signal too high
- 3: Input signal too low
- 4: Invalid measured value
- 6: Error value, i.e. not the calculated value (for mathematics if an input variable is invalid)
- 7: Sensor/input error
- Bit 8: Not assigned
- Bit 9: Alarm storage
- Bit 10..13: Not assigned
- Bit 14: Use error value
- Bit 15: Not assigned

**General status:**

- 1: High speed storage is active
- 2: Additional hour for summer/normal time changeover

Note: A combination of 1 and 2 is possible.

**Status of the limit value ("Limit"):**

- 0: OK, no limit value has been violated
- Bit 0: Lower limit value
- Bit 1: Upper limit value
- Bit 2: Increasing gradient
- Bit 4: Decreasing gradient

Note: A combination is possible.

### 10.16.2 Importing UTF-8-encoded CSV files into spreadsheets

You might encounter problems displaying information if importing UTF-8-encoded CSV files directly into more recent versions of MS Excel™ (2007 and higher).

#### Importing CSV data from the event logbook ("Events") into MS Excel™ (version 2007 and higher):

1. In the menu, select **"Data -> Get external data - From text"**
2. MS Office 365 and higher: In the menu select **"Data -> From text/CSV"**
3. Select the CSV file
4. Follow the instructions in the wizard
5. Select file origin **"Unicode UTF-8"**

## 11 Diagnostics and troubleshooting

The following section contains an overview of possible causes of errors to provide initial assistance during troubleshooting.

## 11.1 General troubleshooting

**⚠ WARNING**

**Danger! Electric voltage**

- ▶ Do not operate the device in an open condition for error diagnosis!

Display	Cause	Remedy
No measured value display; no LED lit	No supply voltage connected	Check supply voltage of device.
	Supply voltage is applied; device or power unit is defective	Replace the power unit or device.
Diagnostic message is displayed	For a list of diagnostic messages, see the next section.	

**i Dead pixels:** Dead pixels refer to pixels on LCD and TFT displays that are defective due to the technology or manufacturing techniques used. The TFT display used can have up to 10 dead pixels (Class III as per ISO 13406-2). These dead pixels do not entitle the user to a warranty claim.

## 11.2 Troubleshooting

The Diagnostics menu is used for the analysis of the device functions and offers comprehensive assistance during troubleshooting. Always proceed as follows to locate the cause of device errors or alarms.

### General troubleshooting procedure

1. Open diagnostic list: lists the 30 most recent diagnostic messages. This can be used to determine which errors are currently present and whether an error has repeatedly occurred.
2. Diagnosis of current measured values: Verify the input signals by displaying the current or scaled measuring ranges. To verify calculations, call up calculated auxiliary variables if necessary.
3. Most errors can be rectified by performing steps 1 and 2. If the error persists follow the troubleshooting instructions in the following sections.
4. If this does not rectify the problem, contact the Service Department. Any time you contact the Service Department please always have the diagnostic number and the information in the main menu under **"Diagnostics -> Device information"** (program name, serial number etc.) to hand.

The contact data for your Endress+Hauser representative can be found on the Internet at [www.endress.com/worldwide](http://www.endress.com/worldwide).

### 11.2.1 Device error/alarm relay

One relay can be used as an alarm relay. The selected output/relay switches if the device detects a system error (e.g., hardware defect) or a malfunction (e.g., cable open circuit). The alarm relay is assigned in the main menu under **"Setup -> Advanced setup -> System -> Fault switching -> Relay x"**. **Factory setting: Relay 1.**

This "alarm relay" switches if "F"-type or "S"-type errors occur, i.e. "M"-type or "C"-type errors do not switch the alarm relay.

## 11.3 Diagnostic information on the local display

The diagnostic message consists of a diagnostic code and event text.

The diagnostic code consists of the status signal as per NAMUR NE 107 and the event number.

Status signal (letter in front of event number)

- **F = Failure.** A malfunction has been detected.  
The measured value of the affected channel is no longer reliable. The cause of the malfunction is to be found in the measuring point. If a controller is connected, it should be switched to manual mode. This status signal can be assigned to an alarm relay in the advanced setup.
- **M = Maintenance required.** Action must be taken as soon as possible.  
The device still measures correctly. Immediate measures are not necessary. Proper maintenance efforts may prevent a possible malfunction in the future.
- **S = Out of specification.** The measuring point is being operated outside specifications. Operation is still possible. There is the risk of increased wear, a shorter operating life or less accurate measurements. The cause of the problem is to be found outside the measuring point.
- **C = Function check.** The device is in Service mode.

Diagnostic code	Event text	Description	Remedial action
F100	Sensor/input error!	Sensor/input error	Check connections and parameters.
F101	Cable open circuit	Cable open circuit	Check connections.
F105	Invalid value!	Measured value is invalid (when calculating --> NAN)	Check connections and process variables.
F201	Device fault	Device error	Contact the Service Department.
F261	Error: RAM	No access to RAM	Contact the Service Department.
F261	Error: Flash	No access to flash	Contact the Service Department.
F261	Error: SRAM	No access to SRAM	Contact the Service Department.
F261	Analog card x is out of order!	Hardware defect detected	Contact the Service Department, replace card.
F261	Power supply out of order!	Hardware defect detected	Contact the Service Department, replace power unit.
M284	Firmware update	Firmware has been updated	No action required. Message can be acknowledged.
M290	The internal flash memory has reached the end of its lifetime. Please replace the device.	The internal flash memory is defective	Replace device.
F301	Error: Cannot load setup	Setup defective	Switch the device off and then on again, re-configure, contact the Service Team.
M302	Setup restored from backup	Setup has been loaded from backup	Check setup.
F303	Error: Device data	Device data defective	Contact the Service Department.
M304	Backup: Device data	Device data defective. However, it was possible to continue working with the backup data	Check settings (serial number).
F307	Error: Customer preset value defective	Customer preset value defective	
F309	Error: Date/time is not set	Invalid date/time (e.g., internal battery is empty)	Device was switched off too long. The date/time must be set again. Battery needs to be replaced (contact the Service Team).
F310	Error: Cannot save setup	The setup could not be saved	Contact the Service Department.
F311	Error: Device data	The device data could not be saved	Contact the Service Department.
F312	Error: Calibration data defective	The calibration data could not be saved	Contact the Service Department.
F312	Analog card x is not calibrated!	Analog card x is not calibrated. The device works with default values, the measured values may be inaccurate under certain circumstances.	Contact the Service Department.

Diagnostic code	Event text	Description	Remedial action
M313	SRAM has been defragmented	SRAM was defragmented after firmware update	No action required. Message can be acknowledged.
F314	Error: Option code	Activation code is no longer correct (incorrect serial number/program name). Option has been switched off and setup preset has been performed.	Enter new code.
M315	No IP address could be obtained from the DHCP server!	No IP address could be obtained from the DHCP server	Check the network cable.
M316	Invalid MAC address!	No or incorrect MAC address	Contact the Service Department.
M317	Battery voltage < 2.5 V. Replace the battery!		Battery needs to be replaced (contact the Service Team).
F348	Firmware cannot be updated: <ul style="list-style-type: none"> <li>■ Checksum incorrect</li> <li>■ Firmware incompatible!</li> </ul>	Firmware update has been aborted because the firmware file is damaged or is not compatible with this device	Contact the Service Department.
M350	Measured value acquisition interrupted for calibration/service work.  Measured value acquisition restarted.	Measured value acquisition was interrupted/reactivated for service/maintenance purposes  Causes include: <ul style="list-style-type: none"> <li>■ Calibration of inputs/outputs</li> <li>■ Firmware update</li> </ul>	No action required. Message can be acknowledged.
M351	The device will restart.	The device is rebooting  Causes include: <ul style="list-style-type: none"> <li>■ Following a firmware update</li> <li>■ Change to device options</li> </ul>	No action required. Message can be acknowledged.
F431	Error: Calibration	Calibration data missing	Contact the Service Department.
M502	Device is locked!	Device is locked. The message appears when an attempt is made to update the firmware, for example	Check lock per digital channel.
F510	Setup was corrected	The device has detected that the configuration is no longer correct. All the parameters affected have been reset to the factory default settings.  Possible causes: <ul style="list-style-type: none"> <li>■ Input cards have been removed or replaced by another type</li> <li>■ An input card is no longer working correctly</li> </ul> A firmware update has caused compatibility problems.  Note: This error message appears each time the device is restarted until at least one change has been made to the configuration.	Check the configuration of the device. If hardware has been replaced, no other action is needed (recommendation: change the operating language so that the error message no longer appears after the next restart).
M520	SMTP: Name could not be resolved (DNS)!  SNTP: Name could not be resolved (DNS)!	Problem with name resolution (DNS)  SMTP: e-mail  SNTP: time synchronization	Check the corresponding settings.
M528	Setup is not compatible with this firmware	An attempt was made to load a setup which is not compatible with this firmware (e.g., another device type)	Check whether the correct file has been selected.
M530	Cannot copy setup.	An error occurred when a setup was loaded from an SD card or USB stick  An error occurred when a setup was saved to an SD card or USB stick	Replace the SD card or USB stick. Setup file defective?
S901	Input signal too low	Input signal too low	Check connections and parameters. Check connected sensor/transmitter.
S902	Input signal too high	Input signal too high	Check connections and parameters. Check connected sensor/transmitter.

Diagnostic code	Event text	Description	Remedial action
M905	Set point x	Set point x has been violated	Note: Diagnostic number only occurs if e-mails are sent.
M906	End limit value x	Set point x no longer violated	Note: Diagnostic number only occurs if e-mails are sent.
F910	This software is not enabled for this device.	The current firmware is not enabled for this hardware	Contact the Service Department.
M920	Too many messages that need to be acknowledged!	There are too many messages that need to be acknowledged. Another message could not be added.	Acknowledge messages.
M921	SD card x% full.	External memory is full	Replace SD card.
M922	No cyclic measurement transfer	The instantaneous values were not read out for a set time	
M922	No cyclic transfer	The device was not read out via fieldbus for a configurable time	Check the communication of the fieldbus. Check PLC.
M924	Error accessing SD card! Error accessing USB stick! SD card is not or wrong formatted! USB stick is not or wrong formatted!	Impossible to access the removable data medium. Causes include: Memory is larger than 32 GB Invalid format (only FAT or FAT32 are permitted)	Check/replace removable data medium.
M925	SD card is write-protected!	SD card is write-protected	Remove write protection.
M927	Insufficient space free on data storage medium!	An attempt was made to save to the SD card or USB stick (setup, screenshot, etc.), but not enough free memory space is available.	Use other SD card/USB stick. Delete files that are no longer needed from the SD card / USB stick.
M927	Insufficient space free on data storage medium!	An attempt was made to save to the WebDAV server but not enough free memory space is available.	Use other WebDAV server. Delete files that are no longer needed from the WebDAV server.
F929	File is damaged!	The file that should be loaded is damaged/invalid (e.g., wrong checksum).  This message can occur in connection with the following actions, for instance: <ul style="list-style-type: none"> <li>▪ Loading setup from SD card/USB stick</li> <li>▪ Firmware update</li> </ul>	Create file again, use other storage medium.
M940	E-mail could not be sent! (x)	E-mail could not be sent  Optional: Error code (x) from server: e.g.: <ul style="list-style-type: none"> <li>▪ 451: Requested action aborted: local processing error</li> <li>▪ 554: Transaction failed. Possible reason: e-mail was not sent as suspected of being SPAM</li> <li>▪ 1: No free buffer</li> <li>▪ 2: No receiver specified</li> </ul>	Check settings/network connection <ul style="list-style-type: none"> <li>▪ 451: Try again</li> <li>▪ 554: Use other e-mail provider</li> </ul>
M941	No connection to the e-mail server!	A connection to the e-mail server could not be established because <ul style="list-style-type: none"> <li>▪ The entered connection data are incorrect</li> <li>▪ The connection is lost</li> </ul>	Check settings/network connection.
M942	SMTP: Fault occurred (x).	An error occurred when sending an e-mail x= error code: 0: SMTP was switched off when the mail was being sent 3: TCP/IP connection was denied 4: TCP/IP connection error 5: SMTP server denied 6: Error during authentication 7: Connection unexpectedly lost 8: Server responded with error code 9: Timeout 10: Internal protocol error	Check settings/network connection.

Diagnostic code	Event text	Description	Remedial action
M944	SMTP: authentication failed!		Check settings/network connection.
M945	SNTP: Time was not synchronized!	Time could not be synchronized via SNTP Possible reasons: <ul style="list-style-type: none"> <li>■ SNTP server temporarily unavailable</li> <li>■ Settings not correct</li> </ul>	<ul style="list-style-type: none"> <li>■ Check settings.</li> <li>■ Check whether the error occurs often. If it does, choose another time server.</li> </ul>
M945	SNTP server 1 not responding. Try server 2.	Time could not be synchronized via SNTP Possible reasons: <ul style="list-style-type: none"> <li>■ SNTP server temporarily unavailable</li> <li>■ Settings not correct</li> </ul>	<ul style="list-style-type: none"> <li>■ Check settings.</li> <li>■ Check whether the error occurs often. If it does, choose another time server.</li> </ul>
M946	Screenshot could not be saved (x)!	Screenshot could not be created Possible causes (x): 0: Error when writing 1: Insufficient free space 2: Bitmap could not be created 3: SD card/USB stick not available or not yet ready	Check/replace the SD card or USB stick.
M947	Modem could not be initialized! Check the cable and modem.	The connected modem could not be initialized by the device	Check the cable and modem.
M950	Cannot load SSL certificate.	Cannot load SSL certificate. Cause: <ul style="list-style-type: none"> <li>■ Invalid file format</li> <li>■ File is damaged</li> </ul>	<ul style="list-style-type: none"> <li>■ Use a certificate with a valid file format.</li> <li>■ Import certificate to device again.</li> </ul>
F951	SSL certificate '...' has expired!	Certificates have an expiry date, i.e. they must be renewed from time to time	Install a new certificate.
M952	SSL certificate '...' expires on ...!	The device warns the user shortly before the certificate expires	Install a new certificate.
M953	x certificates have already been installed. Delete certificates that are no longer required.	The device can manage max. 3 X.509 certificates	Delete a certificate that is already installed and no longer required.
M954	SSL certificate not found: key ID = ...	Unable to establish SSL connection as a suitable certificate is not installed	Install a suitable certificate.
M955	SSL connection denied!		
M980	No connection to the WebDAV server	A connection to the WebDAV server could not be established because the entered connection data are incorrect or the connection has been interrupted	Check settings/network connection.
M981	WebDAV: authentication failed!		Check settings.
M982	WebDAV: directory or file could not be created!	Configured directory path not available.	Create a directory manually in the WebDAV server
M983	WebDAV: Fault	An unassigned error has occurred. The error is displayed in English.	
M984	No Ethernet connection.	The device is not connected by an Ethernet cable	Establish cable connection.
M985	The test cannot be carried out because data are currently being copied by WebDAV.		Repeat later.
M988	Server certificate cannot be loaded. Invalid format.	The file must be Base64-encoded Format: X.509 certificate V3 incl. extension	Create the certificate again according to the specifications.

Diagnostic code	Event text	Description	Remedial action
M989	Private key cannot be loaded. Invalid size/format.	The file must be Base64-encoded. Only RSA keys with max. 2048 bits are supported.	Create the certificate again according to the specifications.
M990	Server certificate cannot be installed.	General error. Unable to read or write to file.	Check the files on the USB stick and create again if necessary. If the error persists, contact the Service Department.

## 11.4 Pending, current diagnostic messages

The diagnostic message that is currently active, the last diagnostic message and the last device restart are displayed in the main menu under **"Diagnostics -> Actual diagnostics"**, **"Diagnostics -> Last diagnostics"** and under **"Diagnostics -> Last restart"**.

## 11.5 Diagnostic list

The last 30 diagnostic messages are displayed in the main menu under **"Diagnostics -> Diagnosis list"** (messages with Fxxx, Sxxx or Mxxx-type error numbers).

The diagnostic list is designed as a ring memory. When the memory is full, the oldest messages are automatically overwritten without generating a message.

The following information is saved:

- Diagnostic number
- Error text
- Date/time

## 11.6 Event logbook

Events such as limit value violations and power failures are displayed in chronological order in the event logbook. It can be found in the main menu under **"Diagnostics -> Event logbook"**. Individual events can be selected and details displayed.

## 11.7 Device information

Important device information such as serial number, firmware version, device name, device options, memory information, SSL certificates etc. are displayed in the main menu under **"Diagnostics -> Device information"**.

 For further information open the online help on the device.

## 11.8 Diagnostics of measured values

Displays the current measured values in the main menu under **"Diagnostics -> Measured values"**. The input signals can be verified here by displaying the scaled and calculated values. To verify calculations, call up calculated auxiliary variables.

## 11.9 Diagnostics of outputs

Displays the current states of the outputs (relays 1-6) in the main menu under **"Diagnostics -> Outputs"**.

## 11.10 Simulation

Various functions/signals can be simulated for test purposes here.

### NOTICE

**Invoke simulation: for the simulation of the relays, see the main menu under "Diagnostics -> Simulation". For the simulation of the measured values, see the main menu under "Expert -> Diagnostics -> Simulation".**

Only the simulated values are recorded during simulation. The simulation is recorded in the event logbook.

- ▶ Do not start simulation if measured value recording must not be interrupted!

### 11.10.1 E-mail test

A test mail can be sent to the selected recipient in the main menu under **"Diagnostics -> Simulation -> E-mail"**.

-  At least one e-mail address must be set beforehand.

### 11.10.2 Testing the WebDAV client

A test file can be sent to the selected WebDAV server in the main menu under **"Diagnostics -> Simulation -> WebDAV Client"**.

-  The settings for the WebDAV server to be addressed must be set beforehand under **"Setup -> Advanced setup -> Application -> WebDAV Client"**.

### 11.10.3 Testing time synchronization/SNTP

Time synchronization (SNTP setting) can be tested in the main menu under **"Diagnostics -> Simulation -> SNTP"**.

-  SNTP must be enabled beforehand in the main menu under **"Setup -> Advanced setup -> System -> Date/time set-up -> SNTP"**.



Note: The test can take some time.

### 11.10.4 Relay test

The relay selected under **"Diagnostics -> Simulation -> Relay x"** can be switched manually in the main menu.

## 11.11 Initializing the modem

Initializes the modem connected (to automatically answer calls). The modem must support the complete AT command syntax.

- 
  - Set the baud rate in the main menu under **"Setup -> Advanced setup -> Communication -> Serial interface"** and select **"RS232"** as the interface type.
  - Connect the modem to the RS232 interface of the device. Only use the modem cable, which is available as an accessory, for this purpose.
-  A GSM modem can only be initialized if a SIM card is inserted and the PIN is entered or the prompt to enter the PIN has been disabled.

## 11.12 Resetting the measuring instrument

The device can be reset to the as-delivered state with a PRESET. This function should only be performed by a service technician.

The function can be found in the main menu under **"Expert -> System -> PRESET"**

 PRESET is only visible under "Expert" once the service code has been entered.

### Procedure for resetting the measuring instrument

The PRESET returns all parameters to the factory default setup! The internal memory content is deleted!

- ▶ Save the setup and measured values on the USB stick or SD card. Then perform a PRESET.
  - ↳ The device is reset to the factory default settings.

## 11.13 Clear memory

 Clear internal memory after commissioning so that the analysis software does not contain any unnecessary data.

## 11.14 Reset analysis

 The analyses should be reset after commissioning so that the analysis software does not contain any unnecessary data.

## 11.15 Updating the device software ("firmware")

Update the device software ("firmware") via USB stick, SD card or web server.

 The function to update the firmware via the web server must be enabled under **"Expert -> Communication -> Ethernet -> Configuration Web server"**.

**There are two ways to update the firmware:**

- In the main menu under **"Operation -> SD card or USB stick -> Update firmware"**
- In the web server under **"Data management -> Update firmware"**

 Make sure that the setup and measured values are saved beforehand on the USB stick/SD card.

Only a service technician should update the device software ("firmware").

After the firmware update, the device restarts.

If an older firmware version (< V2.04.00) is installed on the device, the internal memory must be cleared under **"Expert -> System"**.

# 12 Maintenance

No special maintenance work is required for the device.

## 12.1 Cleaning

### 12.1.1 Cleaning of surfaces not in contact with the medium

- Recommendation: Use a lint-free cloth that is either dry or slightly dampened using water.
- Do not use any sharp objects or aggressive cleaning agents that corrode the surfaces (e.g. displays, housing) and seals.
- Do not use high-pressure steam.
- Observe the degree of protection of the device.

 The cleaning agent used must be compatible with the materials of the device configuration. Do not use cleaning agents with concentrated mineral acids, bases or organic solvents.

## 13 Repair

### 13.1 General notes

The device has a modular design and repairs can be carried out by the customer's electrotechnical personnel. For more information on service and spare parts, contact the supplier.

### 13.2 Spare parts

Product spare parts that are currently available can be found online at: [www.endress.com/onlinetools](http://www.endress.com/onlinetools)

### 13.3 Return

The requirements for safe device return can vary depending on the device type and national legislation.

1. Refer to the web page for information: <https://www.endress.com>
2. If returning the device, pack the device in such a way that it is reliably protected against impact and external influences. The original packaging offers the best protection.

### 13.4 Disposal

#### 13.4.1 IT security

Observe the following instructions before disposal:

1. Delete the data
2. Reset the device

#### 13.4.2 Removing the measuring instrument

1. Switch off the device
2. Carry out the mounting and connection steps from the "Installing the measuring instrument" and "Connecting the measuring instrument" sections in reverse order. Observe the safety instructions.

### 13.4.3 Disposing of the measuring instrument

 If required by the Directive 2012/19/EU on waste electrical and electronic equipment (WEEE), the product is marked with the depicted symbol in order to minimize the disposal of WEEE as unsorted municipal waste. Do not dispose of products bearing this marking as unsorted municipal waste. Instead, return them to the manufacturer for disposal under the applicable conditions.

## 14 Accessories



The accessories currently available for the product can be selected at [www.endress.com](http://www.endress.com):

1. Select the product using the filters and search field.
2. Open the product page.
3. Select **Spare parts & Accessories**.

### 14.1 Device-specific accessories

Description	Order no.
"Industrial Grade" SD card, industry standard, 1GB	71213190
Field Data Manager analysis software with SQL database support (1 x workstation license, Professional version on DVD)	MS20-A5
OPC server software (full version on CD)	RXO20-11

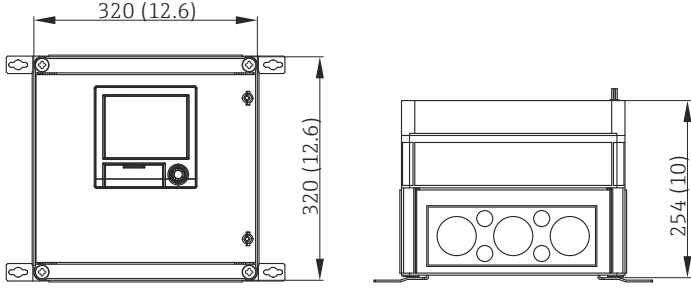
Description	Order no.
<b>Accessories for RXU10 data manager</b>	RXU10- _ _
<b>Designation:</b> Cable set RS232 for connection to PC or modem USB - RS232 converter Cable USB-A - USB-B, 1.8 m (5.9 ft) Configuration software "FieldCare Device Setup" + USB cable	RXU10-B _ RXU10-E _ RXU10-F _ RXU10-G _

Description	Order no.
Field housing IP65 (for panel-mounted device)	RXU10-H _
 <p> 8 Dimensions in mm (in)</p> <p style="text-align: right;">A0021773</p>	

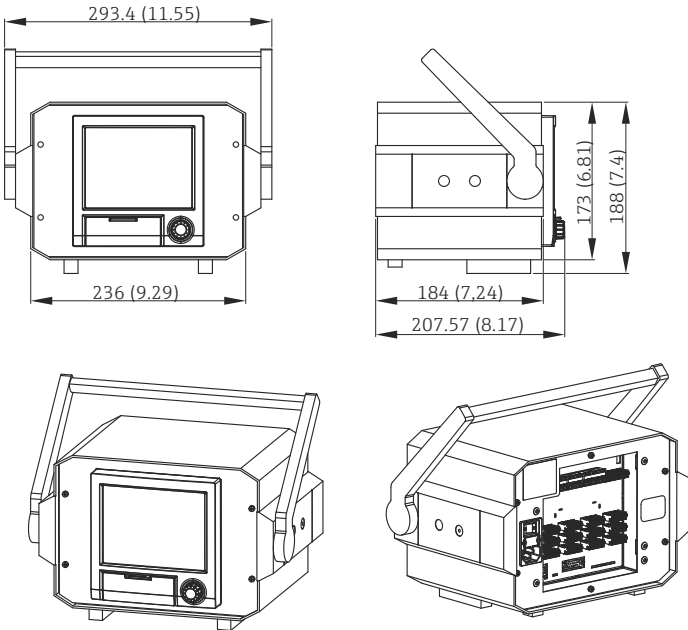
Description	Order no.
<p>Desktop housing (for panel-mounted device), cable with Schuko plug                      Desktop housing (for panel-mounted device), cable with US plug                      Desktop housing (for panel-mounted device), cable with Swiss plug</p>  <p>9 Dimensions in mm (in)</p>	<p>RXU10-I _                      RXU10-J _                      RXU10-K _</p>
<p><b>Version:</b>                      Standard                      Neutral</p>	<p>RXU10- _ 1                      RXU10- _ 2</p>

## 14.2 Communication-specific accessories

### Field Data Manager (FDM) analysis software MS20, MS21

- Field Data Manager (FDM) is a software which provides central data management and visualization. This enables the continuous, tamper-free archiving of process data, e.g. measured values and diagnostic events. "Live data" from connected devices is available. FDM saves the data in an SQL database.
- Supported databases: PostgreSQL (included in the delivery), Oracle or Microsoft SQL server.
- MS20 single-user license: Installing the software on a computer.
- MS21 multi-user license: Several simultaneous users, dependent on the number of available licenses.

 Technical Information TI01022R

[www.endress.com/ms20](http://www.endress.com/ms20)

[www.endress.com/ms21](http://www.endress.com/ms21)

### OPC DA server RXO20

The OPC DA server transmits process data such as instantaneous values or totalizers from connected Endress+Hauser field devices and provides them to the OPC clients in real time. These data can be visualized with OPC client software. Communication takes place via an RS232/RS485 interface or a TCP/IP connection. OPC is used in systems of various sizes in factory and process automation.

 Technical Information TI00122R

[www.endress.com/rxo20](http://www.endress.com/rxo20)

## 14.3 Service-specific accessories

### 14.3.1 Software

#### DeviceCare SFE100

DeviceCare is an Endress+Hauser configuration tool for field devices using the following communication protocols: HART, PROFIBUS DP/PA, FOUNDATION Fieldbus, IO/Link, Modbus, CDI and Endress+Hauser Common Data Interfaces.



Technical Information TI01134S

[www.endress.com/sfe100](http://www.endress.com/sfe100)

#### FieldCare SFE500

FieldCare is a configuration tool for Endress+Hauser and third-party field devices based on DTM technology.

The following communication protocols are supported: HART, WirelessHART, PROFIBUS, FOUNDATION Fieldbus, Modbus, IO-Link, EtherNet/IP, PROFINET and PROFINET APL.



Technical Information TI00028S

[www.endress.com/sfe500](http://www.endress.com/sfe500)

#### Netilion

With the Netilion IIoT ecosystem, Endress+Hauser enables the optimization of plant performance, digitization of workflows, sharing of knowledge and improved collaboration. Drawing upon decades of experience in process automation, Endress+Hauser offers the process industry an IIoT ecosystem designed to effortlessly extract insights from data. These insights allow process optimization, leading to increased plant availability, efficiency, reliability and ultimately a more profitable plant.



[www.netilion.endress.com](http://www.netilion.endress.com)

#### Field Xpert SMT50

Universal, high-performance tablet PC for device configuration.



Technical Information TI01555S

[www.endress.com/smt50](http://www.endress.com/smt50)

#### Field Xpert SMT77 via WLAN

Universal, high-performance tablet PC for device configuration in Ex Zone 1 areas.



Technical Information TI01418S

[www.endress.com/smt77](http://www.endress.com/smt77)

## 14.4 Online tools

Product information about the entire life cycle of the device is available at:

[www.endress.com/onlinetools](http://www.endress.com/onlinetools)

## 14.5 System components

### Surge arrester modules from the HAW product family

Surge arrester modules for DIN rail and field device mounting, for the protection of plants and measuring instruments with power supply and signal/communication lines.

More detailed information: [www.endress.com](http://www.endress.com)

### Process indicators from the RIA product family

Easily readable process indicators with various functions: loop-powered indicators for displaying 4-20 mA values, display of up to four HART variables, process indicators with control units, limit value monitoring, sensor power supply, and galvanic isolation.

Universal application thanks to international hazardous area approvals, suitable for panel mounting or field installation..

For more information, please refer to: [www.endress.com](http://www.endress.com)

#### **RN series active barrier**

Single- or two-channel active barrier for safe separation of 0/4 to -20 mA standard signal circuits with bidirectional HART transmission. In the signal duplicator option, the input signal is transmitted to two galvanically isolated outputs. The device has one active and one passive current input; the outputs can be operated actively or passively.

For more information, please refer to: [www.endress.com](http://www.endress.com)

## **14.6 Instructions for enabling a software option**

Various device options can be enabled via an activation code. Available options can be ordered as an accessory and can be ordered separately. →  66. Once you place your order, you will receive instructions on how to activate the option and a code which must be entered under "**Main menu -> Expert -> System -> Device options -> Activation code**".

## 15 Technical data

### 15.1 Function and system design

Measuring principle	<p>Electronic acquisition, display, recording, analysis, remote transmission and archiving of analog and digital input signals.</p> <p>The device is intended for installation in a panel or cabinet. Operation in a desktop/field housing is possible as an option.</p>
Measuring system	<p>Multichannel data recording system with multicolored TFT display (145 mm (5.7 in) screen size), galvanically isolated universal inputs (U, I, TC, RTD, pulse, frequency), digital inputs, transmitter power supply, limit relays, communication interfaces (USB, Ethernet, optionally RS232/485), optionally with Modbus protocol, 128 MB internal memory, external SD card and USB stick. A free version of the PostgreTMSQL database can be enabled when FDM is installed.</p> <p> The number of inputs available in the basic device can be individually increased using a maximum of 3 plug-in cards. The device supplies power directly to connected two-wire transmitters. The device is configured and operated via the navigator (jog/shuttle dial), via the integrated web server and a PC, or via an external keyboard. Online help facilitates local operation.</p>
Reliability	<p><b>Reliable function</b></p> <p>Depending on the device version, the MTBF is between 52 years and 24 years (calculated based on SN29500 standard at 40 °C)</p> <p><b>Maintainability</b></p> <p>Battery-backed time and data memory. Have the backup battery replaced by a service technician after 10 years.</p> <p><b>Real-time clock</b></p> <ul style="list-style-type: none"> <li>■ Configurable summer/normal time changeover</li> <li>■ Battery buffer. Have the backup battery replaced by a service technician after 10 years.</li> <li>■ Drift: &lt;10 min./year</li> <li>■ Time synchronization possible via SNTP or via digital input</li> </ul> <p><b>Standard diagnostic functions as per NAMUR NE 107</b></p> <p>The diagnostic code consists of the status signal as per Namur NE 107 and the event number.</p> <ul style="list-style-type: none"> <li>■ Cable open circuit, short-circuit</li> <li>■ Incorrect wiring</li> <li>■ Internal device errors</li> <li>■ Overrange/underrange detection</li> <li>■ Ambient temperature out-of-range detection</li> </ul> <p><b>Device error/alarm relay</b></p> <p>One relay can be used as an alarm relay. The selected output/relay switches if the device detects a system error (e.g., hardware defect) or a malfunction (e.g., cable open circuit).</p> <p>This "alarm relay" switches if "F"-type errors occur (F = failure), i.e. "M"-type errors (M= Maintenance required) do not switch the alarm relay.</p>

### Safety

The tamper-proof recorded data are saved and can be transferred to an external SQL database for archiving in a way that prevents subsequent manipulation.

## 15.2 Input

Measured variable	<b>Number of analog universal inputs</b> Standard version without universal inputs. Optional input cards (slot 1-3) with 4 universal inputs (4/8/12) each.
	<b>Number of digital inputs</b> 6 digital inputs
	<b>Number of mathematics channels</b> 4 mathematics channels (optional). Mathematics functions can be freely edited via a formula editor. Integration of calculated values e.g. for totalization.
	<b>Number of limit values</b> 30 limit values (individual channel assignment)
	<b>Function of analog universal inputs</b> You are free to choose between the following measured variables for each universal input: U, I, RTD, TC, pulse input or frequency input. Integration of input variable for totalization e.g. flow rate (m <sup>3</sup> /h) into volume (m <sup>3</sup> ).
	<b>Calculated process variables</b> The values of the universal inputs can be used to perform calculations in the mathematics channels.
Measuring range of analog universal inputs	According to IEC 60873-1: An additional display error of $\pm 1$ digit is permitted for every measured value.

*User-definable measuring ranges per universal input of the multifunction card:*

Measured variable	Measuring range	Maximum measurement error of measuring range (oMR), temperature drift	Input resistance
Current (I)	0 to 20 mA, 0 to 20 mA squared 0 to 5 mA 4 to 20 mA, 4 to 20 mA squared $\pm 20$ mA Overrange: up to 22 mA or -22 mA	$\pm 0.1\%$ oMR Temperature drift: $\pm 0.01\%/K$ oMR	Load: 50 $\Omega$ $\pm 1 \Omega$
Voltage (U) > 1 V	0 to 10 V, 0 to 10 V squared 0 to 5 V 1 to 5 V, 1 to 5 V squared $\pm 10$ V $\pm 30$ V	$\pm 0.1\%$ oMR Temperature drift: $\pm 0.01\%/K$ oMR	$\geq 1 \text{ M}\Omega$
Voltage (U) $\leq 1$ V	0 to 1 V; 0 to 1 V squared $\pm 1$ V $\pm 150$ mV	$\pm 0.1\%$ oMR Temperature drift: $\pm 0.01\%/K$ oMR	$\geq 2.5 \text{ M}\Omega$

Measured variable	Measuring range	Maximum measurement error of measuring range (oMR), temperature drift	Input resistance
Resistance thermometers (RTD)	Pt100: -200 to 850 °C (-328 to 1562 °F) (IEC 60751:2008, α=0.00385) Pt100: -200 to 510 °C (-328 to 950 °F) (JIS C 1604:1984, α=0.003916) Pt100: -200 to 850 °C (-328 to 1562 °F) (GOST 6651-94, α=0.00391) Pt500: -200 to 850 °C (-328 to 1562 °F) (IEC 60751:2008, α=0.00385) Pt500: -200 to 510 °C (-328 to 950 °F) (JIS C 1604:1984, α=0.003916) Pt1000: -200 to 600 °C (-328 to 1112 °F) (IEC 60751:2008, α=0.00385) Pt1000: -200 to 510 °C (-328 to 950 °F) (JIS C 1604:1984, α=0.003916)	4-wire: ±0.1% oMR 3-wire: ±(0.1% oMR + 0.8 K) 2-wire: ±(0.1% oMR + 1.5 K) Temperature drift: ±0.01%/K oMR	
	Cu50: -50 to 200 °C (-58 to 392 °F) (GOST 6651-94, α=4260) Cu50: -200 to 200 °C (-328 to 392 °F) (GOST 6651-94, α=4280) Pt50: -200 to 1100 °C (-328 to 2012 °F) (GOST 6651-94, α=0.00391) Cu100: -200 to 200 °C (-328 to 392 °F) (GOST 6651-94, α=4280)	4-wire: ±0.2% oMR 3-wire: ±(0.2% oMR + 0.8 K) 2-wire: ±(0.2% oMR + 1.5 K) Temperature drift: ±0.02%/K oMR	
	Pt46: -200 to 1100 °C (-328 to 2012 °F) (GOST 6651-94, α=0.00391) Cu53: -200 to 200 °C (-328 to 392 °F) (GOST 6651-94, α=4280)	4-wire: ±0.3% oMR 3-wire: ±(0.3% oMR + 0.8 K) 2-wire: ±(0.3% oMR + 1.5 K) Temperature drift: ±0.02%/K oMR	
Thermocouples (TC)	Type J (Fe-CuNi): -210 to 1200 °C (-346 to 2192 °F) (IEC 60584:2013) Type K (NiCr-Ni): -270 to 1300 °C (-454 to 2372 °F) (IEC 60584:2013) Type L (NiCr-CuNi): -200 to 800 °C (-328 to 1472 °F) (GOST R8.585:2001) Type L (Fe-CuNi): -200 to 900 °C (-328 to 1652 °F) (DIN 43710-1985) Type N (NiCrSi-NiSi): -270 to 1300 °C (-454 to 2372 °F) (IEC 60584:2013) Type T (Cu-CuNi): -270 to 400 °C (-454 to 752 °F) (IEC 60584:2013)	±0.1% oMR from -100 °C (-148 °F) ±0.1% oMR from -130 °C (-202 °F) ±0.1% oMR from -100 °C (-148 °F) ±0.1% oMR from -100 °C (-148 °F) ±0.1% oMR from -100 °C (-148 °F) ±0.1% oMR from -200 °C (-328 °F) Temperature drift: ±0.01%/K oMR	≥ 1 MΩ
	Type A (W5Re-W20Re): 0 to 2500 °C (32 to 4532 °F) (ASTME 988-96) Type B (Pt30Rh-Pt6Rh): 42 to 1820 °C (107.6 to 3308 °F) (IEC 60584:2013) Type C (W5Re-W26Re): 0 to 2315 °C (32 to 4199 °F) (ASTME 988-96) Type D (W3Re-W25Re): 0 to 2315 °C (32 to 4199 °F) (ASTME 988-96) Type R (Pt13Rh-Pt): -50 to 1768 °C (-58 to 3214 °F) (IEC 60584:2013) Type S (Pt10Rh-Pt): -50 to 1768 °C (-58 to 3214 °F) (IEC 60584:2013)	±0.15% oMR from 500 °C (932 °F) ±0.15% oMR from 600 °C (1112 °F) ±0.15% oMR from 500 °C (932 °F) ±0.15% oMR from 500 °C (932 °F) ±0.15% oMR from 100 °C (212 °F) ±0.15% oMR from 100 °C (212 °F) Temperature drift: ±0.01%/K oMR	≥ 1 MΩ
Pulse input (I) <sup>1)</sup>	Min. pulse length 40 µs Max. 12.5 kHz 0 to 7 mA = LOW 13 to 20 mA = HIGH		Load: 50 Ω ±1 Ω
Frequency input (I) <sup>1)</sup>	0 to 10 kHz Overrange: up to 12.5 kHz 0 to 7 mA = LOW 13 to 20 mA = HIGH	±0.02% @ f < 100 Hz of reading ±0.01% @ F ≥ 100 Hz of reading Temperature drift: 0.01% of measured value over the entire temperature range	

1) If a universal input is used as a frequency or pulse input, a series resistor must be used in series connection with the voltage source. Example: 1.2 Ω series resistor at 24 V

### Maximum load of inputs

Limit values for input voltage and current as well as cable open circuit detection/line influence/temperature compensation:

Measured variable	Limit values (steady-state, without destroying input)	Cable open circuit detection/line influence/temperature compensation
Current (I)	Maximum permitted input voltage: 2.5 V Maximum permitted input current: 50 mA	4 to 20 mA range with disengageable cable open circuit monitoring to NAMUR NE 43. The following error ranges apply when NE 43 is switched on: ≤ 3.8 mA: underrange ≥ 20.5 mA: overrange ≤ 3.6 mA or ≥ 21.0 mA: cable open circuit (display shows: - - - -)
Pulse, frequency (I)	Maximum permitted input voltage: 2.5 V Maximum permitted input current: 50 mA	No cable open circuit monitoring
Voltage (U) > 1 V	Maximum permitted input voltage: 35 V	1 to 5 V range with disengageable cable open circuit monitoring: < 0.8 V or > 5.2 V: cable open circuit (display shows: - - - -)
Voltage (U) ≤ 1 V	Maximum permitted input voltage: 24 V	

Measured variable	Limit values (steady-state, without destroying input)	Cable open circuit detection/line influence/temperature compensation
Resistance thermometers (RTD)	Measuring current: $\leq 1$ mA	Maximum barrier resistance (or line resistance): 4-wire: max. 200 $\Omega$ ; 3-wire: max. 40 $\Omega$ Maximum influence of barrier resistance (or line resistance) for Pt100, Pt500 and Pt1000: 4-wire: 2 ppm/ $\Omega$ , 3-wire: 20 ppm/ $\Omega$ Maximum influence of barrier resistance (or line resistance) for Pt46, Pt50, Cu50, Cu53, Cu100 and Cu500: 4-wire: 6 ppm/ $\Omega$ , 3-wire: 60 ppm/ $\Omega$ Cable open circuit monitoring if any connection is interrupted.
Thermocouples (TC)	Maximum permitted input voltage: 24 V	Influence of cable resistance: $<0.001\%/ \Omega$ Internal temperature compensation error: $\leq 2$ K

### Scan rate

Current/voltage/pulse/frequency input: 100 ms per channel

Thermocouples and resistance thermometer: 1 s per channel

### Data storage/save cycle

Selectable save cycle. Choose from: 1s / 2s / 3s / 4s / 5s / 10s / 15s / 20s / 30s / 1min / 2min / 3min / 4min / 5min / 10min / 15min / 30min / 1h

### Typical logging duration

Prerequisites for following tables:

- No limit value violation / integration
- Digital input not used
- Signal analysis 1: off, 2: day, 3: month, 4: year
- No active mathematics channels

 Frequent entries in the event logbook reduce the memory availability.

128 MB internal memory:

Analog inputs	Channels in groups	Storage cycle (weeks, days, hours)				
		5 min	1 min	30 s	10 s	1 s
1	1/0/0/0	668, 4, 14	135, 0, 5	67, 4, 4	22, 3, 20	2, 1, 18
4	4/0/0/0	491, 0, 10	99, 4, 17	49, 6, 12	16, 4, 15	1, 4, 16
8	4/4/0/0	246, 1, 14	49, 6, 1	24, 6, 19	8, 2, 7	0, 5, 20
12	4/4/4/0	164, 2, 4	33, 1, 18	16, 4, 13	5, 3, 21	0, 3, 21

External memory, 1 GB SD card:

Analog inputs	Channels in groups	Storage cycle (weeks, days, hours)				
		5 min	1 min	30 s	10 s	1 s
1	1/0/0/0	12825, 5, 20	2580, 4, 18	1291, 2, 5	430, 4, 14	43, 0, 12
4	4/0/0/0	8672, 5, 12	1749, 6, 13	875, 6, 13	292, 1, 8	29, 1, 14
8	4/4/0/0	4343, 1, 1	875, 1, 17	438, 0, 6	146, 0, 17	14, 4, 7
12	4/4/4/0	2896, 6, 13	583, 3, 21	292, 0, 6	97, 2, 20	9, 5, 4

 The available storage capacity of the internal and external memory can be displayed in the main menu under "**Diagnostics** → **Device information** → **Memory information**". The storage capacity depends on the specific device set-up.

**Converter resolution**

24 bit

**Totalization**

The interim, daily, monthly and yearly value and the total value can be determined (15-digit, 64 bit).

**Analysis**

Recording of quantity/operating time (standard function), also a min/max/median analysis within the set time frame.

Digital inputs

<b>Input level</b>	According to IEC 61131-2, logical "0" (corresponds to -3 to 5 V), activation with logical "1" (corresponds to 12 to 30 V)
<b>Input frequency</b>	Max. 25 Hz
<b>Pulse length</b>	Min. 20 ms (pulse counter)
<b>Pulse length</b>	Min. 100 ms (control input, messages, operating time)
<b>Input current</b>	Max. 2 mA
<b>Input voltage</b>	Max. 30 V

**Selectable functions**

- Functions of the digital input: control input, on/off event, pulse counter (15-digit, 64 bit), operating time, event + operating time, quantity from time, Modbus slave.
- Functions of the control input: start recording, screensaver on, lock setup, time synchronization, set point monitoring on/off, block keyboard/navigator, start/stop analysis.

## 15.3 Output

Auxiliary voltage output

The auxiliary voltage output can be used for loop power supply or to control the digital inputs. The auxiliary voltage is short-circuit proof and galvanically isolated.

<b>Output voltage</b>	24 V <sub>DC</sub> ±15%
<b>Output current</b>	Max. 250 mA

Relay output

A mix of low voltage (230 V) and safety extra low voltage (SELV circuits) is not permitted at the connections of the relay contacts.

**Alarm relay**

1 alarm relay with changeover contact

**Standard relay**

5 relays with NO contact, e.g. for limit value messages (can be configured as NC contact)

**Switching capacity**

- Max. switching capacity: 3 A @ 30 V<sub>DC</sub>
- Max. switching capacity: 3 A @ 250 V<sub>AC</sub>
- Min. switching load: 300 mW

**Switching cycles**

>10<sup>5</sup>

**Galvanic isolation**

The following connections are galvanically isolated from one another:

- Power supply
- Relay outputs
- Digital inputs (isolated from other connections but not from each other)
- Analog inputs
- Analog outputs
- Ethernet
- RS232/RS485
- USB
- Auxiliary voltage output

**15.4 Electrical connection**

Terminal assignment

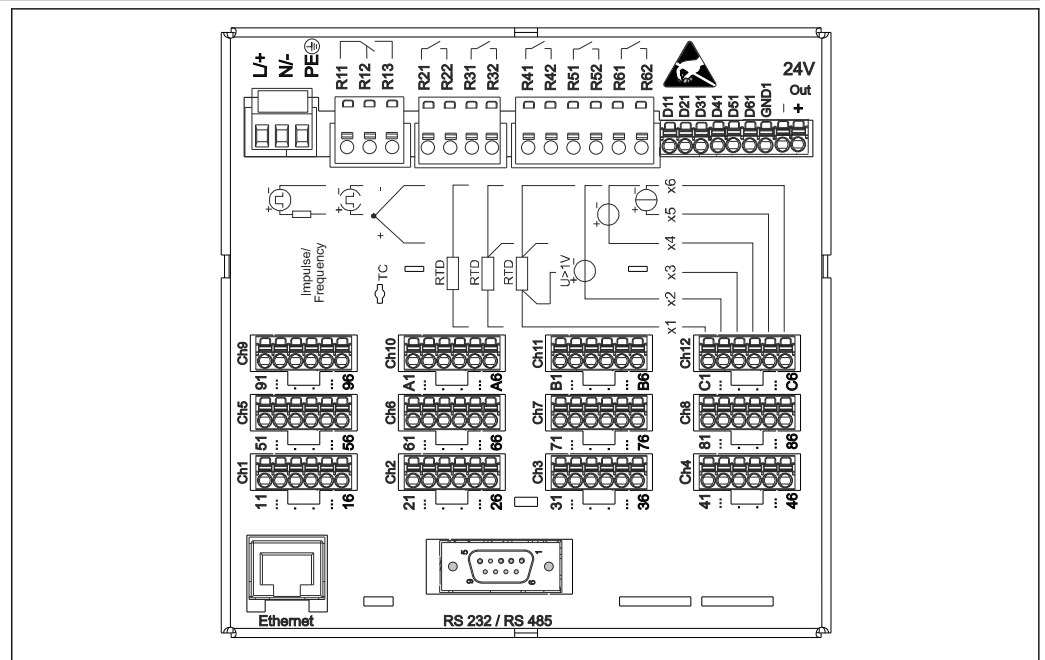

A0019304

10 Terminals on back of device

Available device plugs

- Panel-mounted device: connected to mains via plug-in screw terminals with reverse polarity protection
- Desktop version (option): connected to mains via IEC connector

Supply voltage

- Extra-low voltage power supply unit ±24 V AC/DC (-10% / +15%) 50/60Hz
- Low voltage power supply unit 100 to 230 V AC (±10%) 50/60Hz

**i** An overcurrent protection element (rated current ≤ 10 A) is required for the power cable.

Power consumption

- 100 to 230 V: max. 35 VA
- 24 V: max. 24 VA

The power actually consumed depends on the individual operating state and the device version (LPS, USB, brightness of screen, number of channels, etc.). The active power here is approx. 3 to 20 W.

Power supply failure

Battery-backed time and data memory. The device starts automatically following a power failure.

Electrical connection



Details about the electrical connection: → 13

Cable specifications

**Cable specification, spring terminals**

All connections on the rear of the device are designed as pluggable screw or spring terminal blocks with reverse polarity protection. The spring terminals are unlocked with a slotted screwdriver (size 0).

Note the following when connecting:

- Wire cross-section, auxiliary voltage output, digital I/O and analog I/O: max. 1.5 mm<sup>2</sup> (14 AWG) (spring terminals)
- Wire cross-section, mains: max. 2.5 mm<sup>2</sup> (13 AWG) (screw terminals)
- Wire cross-section, relays: max. 2.5 mm<sup>2</sup> (13 AWG) (spring terminals)
- Stripping length: 10 mm (0.39 in)



No ferrules must be used when connecting flexible wires to spring terminals.

**Shielding and grounding**

Optimum electromagnetic compatibility (EMC) can only be guaranteed if the system components and the cables - both sensor and communication cables - are shielded and the shielding forms as complete a cover as possible. A shielded cable must be used for sensor cables that are longer than 30 m (100 ft). A shield coverage of 90% is ideal. Make sure that the communication cables and sensor cables do not cross when routing them. Connect the shielding as often as possible to the reference ground to ensure optimum EMC protection for the different communication protocols and the connected sensors.

To comply with requirements, three different types of shielding are possible:

- Shielding at both ends
- Shielding at one end on the supply side with capacitance termination at the device
- Shielding at one end on the feed side

The best results are achieved in installations with shielding at one end on the supply side (without capacitance termination at the device). Appropriate internal device wiring measures must be taken to allow unrestricted operation when EMC interference is present. These measures have been taken into account for this device. Operation in the event of disturbance variables as per NAMUR NE21 is thus guaranteed.

Observe national installation requirements and guidelines during installation. Where there are large differences in potential between the individual grounding points, only one point of the shielding is connected directly with the reference ground.



If the shielding of the cable is grounded at more than one point in systems without potential matching, mains frequency equalizing currents can occur. These can damage the signal cable and significantly impact signal transmission. In such cases, the shield of the signal cable should be grounded on one side only and must not be connected to the ground terminal of the housing. The unconnected shield must be insulated.

Overvoltage protection

To avoid high-energy transients on long signal cables, connect a suitable surge arrester upstream (e.g. HAW562).

Connection data interface, communication

#### USB ports (standard):

*1 x USB port type A (host)*

A USB 2.0 port is available on a shielded USB-A socket at the front of the device. A USB stick, for example, can be connected to this interface as a storage medium. An external keyboard or USB hub may also be connected.

*1 x USB port type B (function)*

A USB 2.0 port is available on a shielded USB-B socket at the front of the device. This can be used to connect the device to a laptop for communication, for example.

#### Ethernet interface (standard):

Ethernet interface on back, 10/100 Base-T, plug type RJ45. Connect the device to a PC network (TCP/IP Ethernet) via the Ethernet interface using a hub or switch. Use a standard patch cable (e.g., CAT5E) for the connection. Using DHCP, the device can be fully integrated into an existing network without the need for additional configuration. The device can be accessed from every PC in the network. Normally only the automatic assignment of the IP address must be configured at the client. When the device is started, it can automatically retrieve the IP address, subnet mask and gateway from a DHCP server. Depending on the network to which the device is connected, the settings must be configured directly on the device without using DHCP. Two Ethernet function LEDs are located on the rear of the device.

The following functions are implemented:

- Data communication with PC software (analysis software, configuration software, OPC server)
- Web server
- WebDAV (Web-based Distributed Authoring and Versioning) is an open standard for the provisioning of files via the HTTP protocol. Read the data saved on the device's SD card using a PC. A web browser or a WebDAV client can be selected as the network drive for this on the PC side.

#### Serial RS232/RS485 interface (option):

A combined RS232/RS485 connection is available on a shielded SUB D9 socket at the rear of the device. This can be used for data transfer and to connect a modem. For communication via modem, we recommend an industrial modem with a watchdog function.

- The following baud rates are supported: 9600, 19200, 38400, 57600, 115200
- Max. cable length with shielded cable: 2 m (6.6 ft)(RS232), 1 000 m (3 281 ft)(RS485)

 Only one interface can be used at any one time (RS232 or RS485).

## 15.5 Performance characteristics

Response time

Input	Output	Time [ms]
Current, voltage, pulse	Relay	≤ 550
RTD	Relay	≤ 1150
TC <sup>1)</sup>	Relay	≤ 1550
Cable open circuit detection, current input	Relay	≤ 1150
Sensor error RTD, TC	Relay	≤ 5000
Digital input	Relay	≤ 350

1) If internal measuring point temperature compensation is used, otherwise values as for voltage

Reference operating conditions	<b>Reference temperature</b>	25 °C (77 °F) ±5 K
	<b>Warm-up period</b>	120 min.
	<b>Humidity</b>	20 to 60 % rel. humidity

Hysteresis Can be configured for limit values in the setup

Long-term drift As per IEC 61298-2: max. ±0.1%/year (of measuring range)

## 15.6 Installation

Mounting location and installation dimensions

**i** The device is designed for use in a panel in non-hazardous areas.

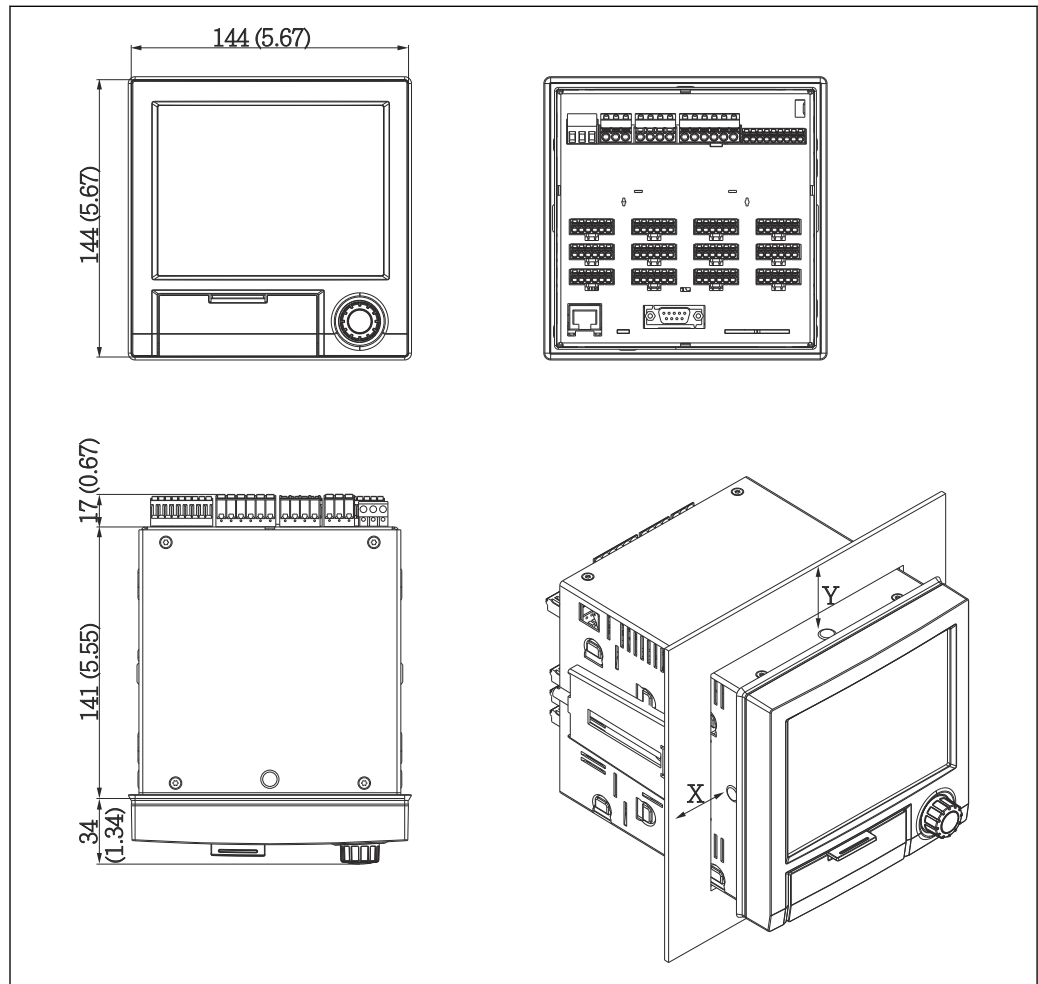

**11** Panel mounting and dimensions in mm (in)

Observe the installation depth of approx. 158 mm (6.22 in) for the device incl. terminals and fastening clips.

- Panel cutout: 138 to 139 mm (5.43 to 5.47 in) x 138 to 139 mm (5.43 to 5.47 in)
- Panel thickness: 2 to 40 mm (0.08 to 1.58 in)
- Angle of vision: from the midpoint axis of the display, 75° to the left and right, 65° above and below.
- A minimum distance of 15 mm (0.59 in) between the devices must be observed if aligning the devices in the Y direction (vertically above one another). A minimum distance of 10 mm (0.39 in) between the devices must be observed if aligning the devices in the X direction (horizontally beside one another).
- Securing to DIN 43 834

Field housing assembly and design (optional)	As an option, the device can be ordered ready-mounted in a field housing with IP65. Dimensions (B x H x D) approx.: 320 mm (12.6 in) x 320 mm (12.6 in) x 254 mm (10 in)
Desktop housing assembly and design (optional)	As an option, the device can be ordered ready-mounted in a desktop housing. Dimensions (W x H x D) approx.: 293 mm (11.5 in) x 188 mm (7.4 in) x 211 mm (8.3 in) (dimensions with bracket, feet and installed device)

## 15.7 Environment

Ambient temperature range	-10 to +50 °C (14 to 122 °F)
Storage temperature	-20 to +60 °C (-4 to +140 °F)
Relative humidity	5 to 85 %, non-condensing
Operating altitude	< 2 000 m (6 561 ft) above MSL
Climate class	To IEC 60654-1: Class B2
Electrical safety	Class I equipment, overvoltage category II Pollution degree 2
Degree of protection	<b>Degree of protection:</b> Panel-mounted device: Front: IP65, NEMA Type 4 encl. Rear: IP20
Electromagnetic compatibility	EMC in accordance with all relevant requirements of the IEC/EN 61326 series and NAMUR NE 21. For details, refer to the Declaration of Conformity. <ul style="list-style-type: none"> <li>■ Interference immunity: as per IEC/EN 61326 series (industrial environment)/NAMUR NE 21 Maximum measurement error &lt;1% of measuring range</li> <li>■ Interference emissions: as per IEC 61326-1 Class A</li> </ul>

## 15.8 Mechanical construction

Design and dimensions Information about design and dimensions →  78

Weight

- Panel-mounted device with maximum configuration: approx. 2.2 kg (4.85 lbs)
- Desktop housing (excluding device): approx. 2.3 kg (5 lbs)
- Field housing (excluding device): approx. 4 kg (8.8 lbs)

Materials	Front frame	Zinc die cast GD-Z410, powder-coated
	Sight glass	Transparent Makrolon plastic (FR clear 099) UL94-V2
	Flap; jog/shuttle dial	Plastic ABS UL94-V2
	Mounting guide rail for PCBs; motherboard fixing unit; display retainer plate	Plastic PA6-GF15 UL94-V2
	Seal to panel wall; seal to display; seal in flap; seal to navigator	Rubber EPDM 70 Shore A
	Casing; rear panel	Galvanized sheet steel St 12 ZE

 All materials are silicone-free.

### Materials of desktop housing

- Housing half-panels: sheet steel, electrolytically plated (powder-coated)
- Side sections: aluminum extruded section (powder-coated)
- Section ends: colored polyamide

## 15.9 Display and operating elements

Operating concept The device can be operated directly on site, or via remote configuration with the PC via interfaces and operating tools (web server, configuration software).

### Web server

A web server is integrated into the device. The web server offers the following range of functions:

- Easy configuration without additional installed software
- Instantaneous value display and diagnostics information
- Display of current measured value curves via web browser (remote control)
- Display of historical measured data in numerical format or as a curve
- Display of events and logbook entries
- Loading/saving of device configuration
- Device firmware update
- Printout of device configuration

### Integrated Operating Instructions

Thanks to the device's simple operating concept, it is possible to commission the device for many applications without a hard copy of the Operating Instructions. The device has an integrated help function and displays operating instructions directly on screen if the navigator (jog/shuttle dial) is pressed for longer than 3 seconds.

Languages The following languages can be selected in the operating menu: German, English, Spanish, French, Italian, Dutch, Swedish, Polish, Portuguese, Czech, Russian, Japanese, Chinese (Traditional), Chinese (Simplified)

Local operation

**Display elements**

*Type*

TFT color display

*Size (diagonal screen measurement)*

145 mm (5.7 in)

*Resolution*

VGA 307,200 pixels (640 x 480 pixels)

*Backlight*

70,000 h half-life (= half brightness)

*Number of colors*

262,000 viewable colors, 256 colors used

*Viewing angle*

Viewing angle: 130° vertical, 150° horizontal

*Screen displays*

- Background color white
- Active channels can be assigned to up to 4 groups. To clearly identify these groups, they can be assigned a name, such as "Temp. boiler 1" or "daily averages".
- Linear scaling
- Measured value history: Quick retrieval of historic data with zoom function
- Preformatted screen displays such as horizontal or vertical curve presentation, bar graph display or digital display.

**Operating elements**

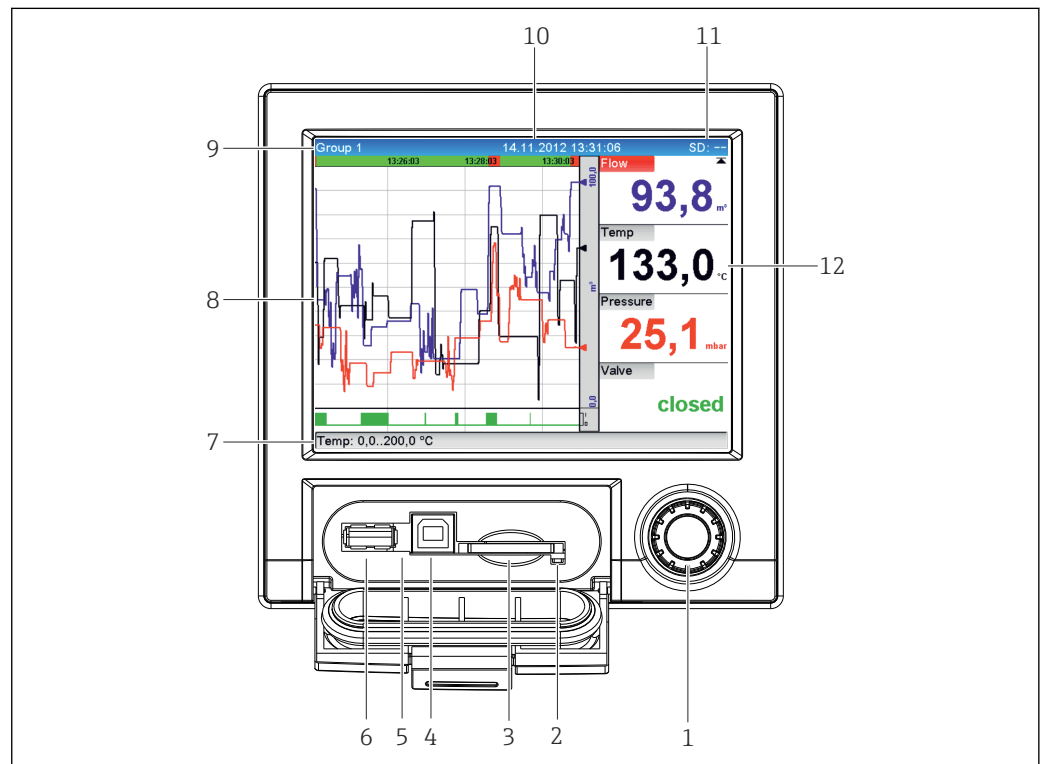

12 Front of device with open flap

A0047011

Item no.	Operating function (display mode = display of measured values) (Setup mode = operation in the Setup menu)
1	"Navigator": Jog/shuttle dial for operating with additional press/hold function. In display mode: turn the dial to switch between the various signal groups. Press the dial to display the main menu. In setup mode or in a selection menu: Turn the dial anticlockwise to move the bar or the cursor up or to the left, changes the parameter. Turning clockwise moves the bar or cursor down or to the right, changes the parameter.
2	LED at SD slot. Orange LED lit or flashing when the device is accessing the SD card. <b>Do not remove the SD card if the LED is lit or flashing! Risk of data loss!</b>
3	Slot for SD card
4	USB-B socket "Function", e.g., to connect to a PC or laptop
5	Green LED lit: power supply present
6	USB-A socket "Host", e.g., for USB memory stick or external keyboard
7	In display mode: alternating status display (e.g., set zoom range) of the analog or digital inputs in the appropriate color of the channel. In setup mode: different information can be displayed here depending on the display type.
8	In display mode: window for measured value display (e.g., curve display). In setup mode: display of operating menu
9	In display mode: current group name, evaluation type In setup mode: name of the current operating item (dialog title)
10	In display mode: displays current date/time In setup mode: --
11	In display mode: alternating display indicating the percentage space on the SD card or USB stick that has already been used. Status symbols are also displayed in alternation with the memory information. In setup mode: the current "direct access" operating code is displayed
12	In display mode: display of current measured values and the status in the event of an error/alarm condition. In the case of counters, the type of counter is displayed as a symbol.  If a measuring point has limit value status, the corresponding channel identifier is highlighted in red (quick detection of limit value violations). During a limit value violation and device operation, the acquisition of measured values continues uninterrupted.

Remote operation

**Device access via operating tools**

Device configuration and measured value retrieval can also be done via interfaces. The following operating tools are available for this purpose:

Operating tool	Functions	Access via
Field Data Manager (FDM) analysis software, SQL database support	<ul style="list-style-type: none"> <li>▪ Export of saved data (measured values, analyses, event logbook)</li> <li>▪ Visualization and processing of saved data (measured values, analyses, event logbook)</li> <li>▪ Safe archiving of exported data in an SQL database</li> </ul>	RS232/RS485, USB, Ethernet
Web server (integrated into the device; access via browser)	<ul style="list-style-type: none"> <li>▪ Display of current and historical data and measured value curves via the web browser</li> <li>▪ Easy configuration without additional installed software</li> <li>▪ Remote access to device and diagnostic information</li> </ul>	Ethernet, or Ethernet over USB
OPC server (optional)	The following instantaneous values can be provided: <ul style="list-style-type: none"> <li>▪ Analog channels</li> <li>▪ Digital channels</li> <li>▪ Mathematics</li> <li>▪ Totalizer</li> </ul>	RS232/RS485, USB, Ethernet
"FieldCare/ DeviceCare" configuration software	<ul style="list-style-type: none"> <li>▪ Device configuration</li> <li>▪ Loading and saving of instrument data (upload/download)</li> <li>▪ Documentation of the measuring point</li> </ul>	USB, Ethernet

---

**System integration**

The device has (optional) fieldbus interfaces for exporting process values. Measured values and statuses can also be transmitted to the device via fieldbus. Depending on the bus system, alarms and faults occurring during data transmission are displayed (e.g., status byte). The process values are transmitted in the same units that are used to display the values on the device.

**Ethernet**

The following functions are implemented:

- Data communication with PC software (analysis software, configuration software, OPC server)
- Web server

**Modbus RTU/TCP slave**

The device can be connected to a Modbus system via RS485 or Ethernet interface. Up to 12 analog inputs and 6 digital inputs can be transmitted via Modbus and stored in the device.

## 15.10 Certificates and approvals

Current certificates and approvals for the product are available at [www.endress.com](http://www.endress.com) on the relevant product page:

1. Select the product using the filters and search field.
2. Open the product page.
3. Select **Downloads**.

## 15.11 Ordering information

Detailed ordering information is available from your nearest sales organization [www.addresses.endress.com](http://www.addresses.endress.com) or in the Product Configurator at [www.endress.com](http://www.endress.com):

1. Select the product using the filters and search field.
2. Open the product page.
3. Select **Configuration**.

## 16 Appendix

### 16.1 Operating items in the "Expert" menu

The parameter groups for the Expert setup contain all the parameters of the operating menus: System, Input and Output Setup, Communication, Application, Diagnostics as well as other parameters that are reserved for experts only.

 For most settings, the "Setup" or "Expert" menu must be quit before the settings are adopted. However, settings such as the date/time are accepted immediately.

---

#### Direct access

---

<b>Navigation</b>	 Expert → Direct access
<b>Description</b>	Direct access to active operating items (rapid access). Entering the direct access code takes you directly to the desired operating parameter. The direct access code is displayed in the Setup menu on the top right of the display (e.g., 00000-000).
<b>Text entry</b>	(e.g., 00000-000)

#### 16.1.1 "System" submenu

Basic settings that are needed to operate the device (e.g., date, time, etc.)

---

#### Language

---

<b>Navigation</b>	 Expert → System → Language Direct access code: 010000-000
<b>Description</b>	Select the operating language of the device
<b>Options</b>	German, English, Spanish, French, Italian, Dutch, Polish, Portuguese, Russian, Swedish, Czech, Japanese, Chinese (Simplified), Chinese (Traditional)
<b>Factory setting</b>	English or preset to customer's preferred language

---

#### Device tag

---

<b>Navigation</b>	 Expert → System → Device tag Direct access code: 000031-000
<b>Description</b>	Individual device tag
<b>User entry</b>	Text entry (max. 32 characters)
<b>Factory setting</b>	Unit 1

---

**Temperature unit**



---

<b>Navigation</b>	 Expert → System → Temp. unit Direct access code: 100001-000
<b>Description</b>	Selection of temperature unit. All directly connected thermocouples or resistance thermometers (RTD) are displayed in the preset engineering units.
<b>Options</b>	°C, °F, K
<b>Factory setting</b>	°C

---

**Decimal separator**



---

<b>Navigation</b>	 Expert → System → Decimal separator Direct access code: 100003-000
<b>Description</b>	Select the decimal separator to be used when displaying numbers.
<b>Options</b>	Comma, point
<b>Factory setting</b>	Comma

---

**Fault switching**



---

<b>Navigation</b>	 Expert → System → Fault switching Direct access code: 100002-000
<b>Description</b>	The selected output/relay switches if the device detects a system error (e.g., hardware defect) or a malfunction (e.g., cable open circuit).
<b>Options</b>	Not used, Relay x All the available relays are displayed.
<b>Factory setting</b>	Relay 1

---

**Keyboard layout**

---

<b>Navigation</b>	 Expert → System → Keyboard layout Direct access code: 100020/000
<b>Description</b>	Select keyboard layout. Only relevant if external keyboard is used.

<b>Options</b>	Germany, Switzerland, France, USA, USA International, UK, Italy
<b>Factory setting</b>	Germany

---

### Swap mouse buttons

---

<b>Navigation</b>	 Expert → System → Swap mouse buttons Direct access code: 100050/000
-------------------	--

**Description** Swap function of left and right mouse button.

**Options** No, Yes

**Factory setting** No

---

### Paper size

---

<b>Navigation</b>	 Expert → System → Paper size Direct access code: 540004/000
-------------------	---

**Description** Select the paper size of the printer connected to the PC.

**Options** DIN A4, US Letter

**Factory setting** DIN A4

---

### Lock operation

---

<b>Navigation</b>	 Expert → System → Lock operation Direct access code: 100060/000
-------------------	--

**Description** Local operation is locked in cases of inactivity once the set time has elapsed to prevent inadvertent operation (e.g., when cleaning the device). The device is unlocked by pressing the navigator or the OK operating key for 3 s. When using an external keyboard, the device is unlocked with the key combination "Ctrl-Alt-Del".



**Options** Never, After 2 (5, 10, 15) minutes

**Factory setting** After 5 minutes

---

### PRESET

---

<b>Navigation</b>	 Expert → System → PRESET Direct access code: 000044-000
<b>Description</b>	Caution: Resets all the parameters to the factory settings!  Only visible/editable if the service code has been entered.
<b>Options</b>	No, Factory reset, Customer setting

---

### Clear memory

---

<b>Navigation</b>	 Expert → System → Clear memory Direct access code: 059000-000
<b>Description</b>	Clear internal memory
<b>Options</b>	No, Yes

---

### Confirm deletion

---

<b>Navigation</b>	 Expert → System → Confirm deletion Direct access code: 059001-000
<b>Description</b>	Confirm that you want to clear the memory.
<b>Options</b>	No, Yes
<b>Factory setting</b>	No

---

### "Date/time setup" (submenu)

---

<b>Navigation</b>	 Expert → System → Date/time setup
<b>Description</b>	Contains settings for date/time.

---

### Date format

---

<b>Navigation</b>	 Expert → System → Date/time setup → Date format Direct access code: 110000-000
<b>Description</b>	Select the format in which the date should be displayed.
<b>Options</b>	DD.MM.YYYY, MM/DD/YYYY, YYYY-MM-DD

---

**Factory setting** DD.MM.YYYY

---

### Time format

---

**Navigation**  Expert → System → Date/time setup → Time format  
Direct access code: 110001-000

**Description** Select the format in which the date should be displayed

.

**Options** 24 hour, 12 hour AM/PM

**Factory setting** 24 hour

---

### "Date/time" submenu

---

**Navigation**  Expert → System → Date/time setup → Date/time

**Description** Contains parameters for setting the date/time.

---

### UTC time zone

---

**Navigation**  Expert → System → Date/time setup → Date/time → UTC time zone  
Direct access code: 120000-000

**Description** Display of the current UTC time zone is on (UTC = universal time coordinated).

---

### Current date/time

---

**Navigation**  Expert → System → Date/time setup → Date/time → Current date/time  
Direct access code: 120003-000

**Description** Displays the current date and the current time.

---

### "Change date/time" submenu

---

**Description** Contains parameters for changing the date/time.

**Navigation**  Expert → System → Date/time setup → Change date/time

---

**UTC time zone**



---

<b>Navigation</b>	 Expert → System → Date/time setup → Date/time → Change date/time → UTC time zone Direct access code: 120010-000
<b>Description</b>	Set your UTC time zone (UTC = universal time coordinated).
<b>Options</b>	-12:00, -11:00: Samoa, -10:00: Hawaii, -09:30: Marquesas, -09:00: Alaska, -08:00: LA, -07:00: Denver, -06:00: Chicago, -05:00: New York, -04:00: Caracas, -03:30: St.John's, -03:00: Brasilia, -02:00: Atlantic, -01:00: Azores, +00:00: London, +01:00: Berlin, +02:00: Cairo, +03:00: Moscow, +03:30: Tehran, +04:00: Abu Dhabi, +04:30: Kabul, +05:00: Islamabad, +05:30: New Delhi, +05:45: Kathmandu, +06:00: Dhaka, +06:30: Pyinmana, +07:00: Bangkok, +08:00: Peking, +08:45, +09:00: Tokyo, +09:30: Adelaide, +10:00: Canberra, +10:30: Lord-Howe, +11:00:Solom.Isl., +11:30: Norfolk, +12:00: Auckland, +12:45: Chatham, +13:00, +14:00

---

**Date/time**



---

<b>Navigation</b>	 Expert → System → Date/time setup → Date/time → Change date/time → Date/time Direct access code: 120013-000
<b>Description</b>	Set the current date and time for the device.
<b>User entry</b>	Date/time in set format

---

**"NT/ST changeover" submenu**



---

<b>Navigation</b>	 Expert → System → Date/time setup → NT/ST changeover
<b>Description</b>	Contains settings for normal time/summer time changeover.

---

**NT/ST changeover**



---

<b>Navigation</b>	 Expert → System → Date/time setup → NT/ST changeover → NT/ST changeover Direct access code: 110002-000
<b>Description</b>	Function for summer/normal time changeover. Automatic: Changes to the local regional regulations; Manual: Changeover times can be set in the following addresses; Off: No changeover times required.
<b>Options</b>	Off, Manual, Automatic
<b>Factory setting</b>	Automatic

---

**NT/ST region**

---

<b>Navigation</b>	 Expert → System → Date/time setup → NT/ST changeover → NT/ST region Direct access code: 110003-000
<b>Description</b>	Selects the regional settings for summer/normal time changeover. Only visible if NT/ST changeover = Automatic.
<b>Options</b>	Europe, USA
<b>Factory setting</b>	Europe

---

**Begin summer time**



---



---

**Occurrence**



---

<b>Navigation</b>	 Expert → System → Date/time setup → NT/ST changeover → Occurrence Direct access code: 110005-000
<b>Description</b>	Day, when in the spring a change from normal to summer time occurs. Visible for NT/ST changeover = Automatic or Manual. Only editable if NT/ST changeover = Manual.
<b>Options</b>	1., 2., 3., 4., Last
<b>Factory setting</b>	Last

---

**Day**



---

<b>Navigation</b>	 Expert → System → Date/time setup → NT/ST changeover → Day Direct access code: 110006-000
<b>Description</b>	Day, when in the spring a change from normal to summer time occurs. Visible for NT/ST changeover = Automatic or Manual. Only editable if NT/ST changeover = Manual.
<b>Options</b>	Sunday, Monday, Tuesday, Wednesday, Thursday, Friday, Saturday
<b>Factory setting</b>	Sunday

---

**Month**



---

<b>Navigation</b>	 Expert → System → Date/time setup → NT/ST changeover → Month Direct access code: 110007-000
<b>Description</b>	Month, when in the spring a change from normal to summer time occurs. Visible for NT/ST changeover = Automatic or Manual. Only editable if NT/ST changeover = Manual.
<b>Options</b>	January, February, March, April, May, June, July, August, September, October, November, December
<b>Factory setting</b>	March

---

### Date

---

<b>Navigation</b>	 Expert → System → Date/time setup → NT/ST changeover → Date Direct access code: 110008-000
<b>Description</b>	Date next spring when a change from normal to summer time occurs. Only visible if NT/ST changeover = Automatic or Manual. Cannot be edited.

---

### Time

---

<b>Navigation</b>	 Expert → System → Date/time setup → NT/ST changeover → Time Direct access code: 110009-000
<b>Description</b>	Time at which the changeover from normal time to summer time is forwarded by one hour (format: hh:mm). Visible for NT/ST changeover = Automatic or Manual. Only editable if NT/ST changeover = Manual.
<b>User entry</b>	Time in set time format
<b>Factory setting</b>	02:00

---

### End summer time

---



---

### Occurrence

---

<b>Navigation</b>	 Expert → System → Date/time setup → NT/ST changeover → Occurrence Direct access code: 110011-000
<b>Description</b>	Day, when in the autumn a change from summer to normal time occurs. Visible for NT/ST changeover = Automatic or Manual. Only editable if NT/ST changeover = Manual.

**Options** 1., 2., 3., 4., Last

**Factory setting** Last

---

## Day

---

**Navigation**  Expert → System → Date/time setup → NT/ST changeover → Day  
Direct access code: 110012-000

**Description** Day, when in the autumn a change from summer to normal time occurs.  
Visible for NT/ST changeover = Automatic or Manual. Only editable if NT/ST changeover = Manual.

**Options** Sunday, Monday, Tuesday, Wednesday, Thursday, Friday, Saturday

**Factory setting** Sunday

---

## Month

---

**Navigation**  Expert → System → Date/time setup → NT/ST changeover → Month  
Direct access code: 110013-000

**Description** Month, when in the autumn a change from summer to normal time occurs.  
Visible for NT/ST changeover = Automatic or Manual. Only editable if NT/ST changeover = Manual.

**Options** January, February, March, April, May, June, July, August, September, October, November, December

**Factory setting** October

---

## Date

---

**Navigation**  Expert → System → Date/time setup → NT/ST changeover → Date  
Direct access code: 110014-000

**Description** Date next autumn when summer time changes back to normal time.  
Only visible if NT/ST changeover = Automatic or Manual. Cannot be edited.

---

## Time

---

<b>Navigation</b>	 Expert → System → Date/time setup → NT/ST changeover → Time Direct access code: 110015-000
<b>Description</b>	Time at which the changeover from summer time to normal time is turned back by one hour (in the set time format). Visible for NT/ST changeover = Automatic or Manual. Only editable if NT/ST changeover = Manual.
<b>User entry</b>	Time in set time format
<b>Factory setting</b>	02:00

---

### "SNTP" submenu

---

<b>Navigation</b>	 Expert → System → Date/time setup → SNTP
<b>Description</b>	Contains settings for time synchronization using the Simple Network Time Protocol (SNTP).

---

### SNTP

---

<b>Navigation</b>	 Expert → System → Date/time setup → SNTP Direct access code: 110020-000
<b>Description</b>	If switched on, time synchronization is carried out via SNTP once a day. Note: Only possible via Ethernet. Port 123 must be open in the firewall. The user/network administrator is responsible for the accuracy of the time server.
<b>Options</b>	No, Yes
<b>Factory setting</b>	No

---

### SNTP server 1

---

<b>Navigation</b>	 Expert → System → Date/time setup → SNTP server → SNTP server 1 Direct access code: 110021-000
<b>Description</b>	Please specify the address of the time server (or the IP address). Note: The DNS server must be configured (see Communication/Ethernet). Your administrator can provide the address where necessary.
<b>User entry</b>	Text field

---

### SNTP server 2

---

**Navigation**

 Expert → System → Date/time setup → SNTP server → SNTP server 2  
Direct access code: 110025-000

**Description**

Shows the IP address of the time server if it was automatically allocated via DHCP. Non-editable display text.

 An attempt is always made to synchronize the time via SNTP server 1 first (provided it is configured)  
DHCP must be switched on (see Communication/Ethernet).  
DHCP server: Option 42

---

**"Security" submenu**

---

**Navigation**

 Expert → System → Security

**Description**

Contains settings that protect the device against unauthorized operation and configuration.

---

**Protected by**

---

**Navigation**

 Expert → System → Security → Protected by  
Direct access code: 100006-000

**Description**

Configure how the device should be protected.

**Options**

Open access, Access code, User roles

**Factory setting**

Open access

---

**Access code**

---

**Navigation**

 Expert → System → Security → Access code  
Direct access code: 100000-000

**Description**

This code can be used to protect the setup from unauthorized access. In order to change any parameter, the correct code must be entered. Factory setting is "0", this means changes can be done at any time.

Hint: Make a note of the code and store in a safe place.

Only visible if "Protected by" = "Access code"

**User entry**

4-digit number



**Factory setting**

0

---

**Set point code**



---

<b>Navigation</b>	 Expert → System → Security → Set point code Direct access code: 100030-000
<b>Description</b>	<p>If the unit is protected by an access code a set point code can also be defined. The user can change the limit values once the set point code is entered. All other operating positions remain locked, however.</p> <p>Only visible if an activation code has been defined.</p> <p>Factory default: "0" means that alarm limit values can only be changed by entering the access code.</p> <p> Alarm set point code and access code should not be identical!</p>
<b>User entry</b>	4-digit number
<b>Factory setting</b>	0

---

### Lock hardware

---

<b>Navigation</b>	 Expert → System → Security → Lock hardware Direct access code: 100099-000
<b>Description</b>	<p>Device functions/interfaces that are not used can be switched off for security reasons.</p> <p> Fieldbus systems may also be affected in the case of Ethernet or the serial interface. Follow the operating instructions.</p>
<b>Options</b>	<b>Panel version:</b> Ethernet (all ports/services), USB-A socket front, USB-A socket back, USB-B socket front, serial interface, SD card
<b>Factory setting</b>	No lock

---

### "Authentication" submenu

---

<b>Navigation</b>	 Expert → System → Security → Authentication
<b>Description</b>	<p>Define a password for the relevant user role. This password allows access to device settings and functions depending on the user role in question.</p> <p>Only visible if "Protected by" = "User roles"</p>

---

### Operator ID: operator Password

---

<b>Navigation</b>	 Expert → System → Security → Authentication → Password Direct access code: 470105/000
<b>Description</b>	Enter the password for the user account.

**Options** Text entry max. 12 characters

**Factory setting** operator

---

### Administrator

**ID: admin**

**Password**

**Navigation**  Expert → System → Security → Authentication → Password  
Direct access code: 470102/000

**Description** Enter the password for the user account.

**Options** Text entry max. 12 characters

**Factory setting** admin

---

### Service

**ID: service**

**Password**

**Navigation**  Expert → System → Security → Authentication → Password  
Direct access code: 470101/000

**Description** Enter the password for the user account.

**Options** Text entry max. 12 characters

**Factory setting** service

---

### "External memory" submenu

**Navigation**  Expert → System → External memory

**Description** Settings for the external data carrier, amongst other things which data is to be stored in which format on the external data carrier.

---

### Save as

**Navigation**  Expert → System → External memory → Save as  
Direct access code: 140000-000

<b>Description</b>	"Protected format": All data is stored in a manipulation-protected encrypted format. This data can only be visualized by the PC analysis software. "Open format": Data is stored in a CSV format, this can be opened by a number of different programs (Attention: no manipulation protection).
<b>Options</b>	Protected format, Open format (*.csv)
<b>Factory setting</b>	Protected format

---

## SD card



---



---

## Memory build-up



---

<b>Navigation</b>	 Expert → System → External memory → Memory build-up Direct access code: 140001-000
<b>Description</b>	"Stack memory": No more data can be stored once the data carrier is full. "Ring memory": Once the data carrier is full, the oldest data is deleted so that new data can be stored (First in first out (FIFO)).  The "Ring memory" setting refers only to the automatic storage of measured values. Manual save functions ("Operation -> SD card -> Update/Save measured values") are not affected.
<b>Options</b>	Stack memory, Ring memory (FIFO)  "Ring memory" can be selected only if "Save as" is set to "Protected format" (and not "CSV").
<b>Factory setting</b>	Stack memory

---

## Warning at

---

<b>Navigation</b>	 Expert → System → External memory → Warning at Direct access code: 140005-000
<b>Description</b>	Issues a warning before the data carrier is x% full. A warning is indicated on the device and this is also stored in the event buffer. A relay can also be switched.  Only for external SD card (does not apply to USB stick)!
<b>User entry</b>	0 to 99%
<b>Factory setting</b>	90

---

**Switches relay**



---

<b>Navigation</b>	 Expert → System → External memory → Switches relay Direct access code: 140006-000
<b>Description</b>	When the warning "Data carrier full" is displayed, a relay can also be switched on.
<b>Options</b>	Not used, Relay x All the available relays are displayed.
<b>Factory setting</b>	Not used

---

**CSV settings**



---

 Also configurable if "Protected format" is set.

---

**Separator for CSV**



---

<b>Navigation</b>	 Expert → System → External memory → Separator for CSV Direct access code: 140002-000
<b>Description</b>	Specify the separator used in the application (e.g., in Excel: semicolon).
<b>Options</b>	Comma, Semicolon
<b>Factory setting</b>	Semicolon

---

**Date/time**



---

<b>Navigation</b>	 Expert → System → External memory → Date/time Direct access code: 140003-000
<b>Description</b>	Select if the date and time should be stored in one column or two separate columns when data is saved in CSV format.
<b>Options</b>	One column, Separate columns
<b>Factory setting</b>	Separate columns

---

**Operational time**



---

<b>Navigation</b>	 Expert → System → External memory → Operational time Direct access code: 140004-000
<b>Description</b>	Select the format in which operating times will be stored/displayed.
<b>Options</b>	0 seconds, 0.0000 hours, 0.00000 days, 0000h00:00
<b>Factory setting</b>	0000h00:00

---

### "Messages" submenu

---

<b>Navigation</b>	 Expert → System → Messages
<b>Description</b>	Contains settings for displaying/acknowledging messages. Examples of messages include: messages triggered by limit values; messages triggered by a digital input; error messages; etc.

---

### Acknowledging messages

---

<b>Navigation</b>	 Expert → System → Messages → Acknowledging messages Direct access code: 100040-000
<b>Description</b>	The time the message is acknowledged can be saved in the event logbook.
<b>Options</b>	Do not save, Save
<b>Factory setting</b>	Do not save

---

### Switches relay

---

<b>Navigation</b>	 Expert → System → Messages → Switches relay Direct access code: 100042-000
<b>Description</b>	A relay can be switched as soon as a message that has to be confirmed is displayed (e.g., on/off event, device errors etc.). The relay adopts the initial status as soon as all messages have been confirmed.
<b>Options</b>	Not used, Relay x All the available relays are displayed.
<b>Factory setting</b>	Not used

---

### "Screensaver" submenu

---

<b>Navigation</b>	 Expert → System → Screensaver
-------------------	---

**Description** To increase the life span of the LCD, the rear illumination can be switched off (= screensaver).

---

### Screensaver

---

**Navigation**  Expert → System → Screensaver → Screensaver  
Direct access code: 160000-000

**Description** "Switched off": LCD is always switched on  
"Switch on for x min.": Display goes dark after x minutes. All other functions remain in operation. Press an operating key: Illumination is switched back on.  
"Switched daily": Enter time span.

**Options** Switched off, On after 10 min, On after 30 min, On after 60 min, Switched daily, Control input

**Factory setting** Switched off  
This setting has no effect if the screensaver is controlled by a digital input.

---

### ON daily from

---

**Navigation**  Expert → System → Screensaver → ON daily from  
Direct access code: 160001-000

**Description** Set time (hh:mm) as of when the screensaver should be switched on (e.g., shift end time).

 The screensaver is switched off as soon as the device is operated via on-site operation. After 1 min of inactivity, it switches back on automatically.

Only visible if screensaver = Switched daily

**User entry** Time (hh:mm)

**Factory setting** 20:00

---

### OFF daily from

---

**Navigation**  Expert → System → Screensaver → OFF daily from  
Direct access code: 160002-000

**Description** Set time (hh:mm) as of when the screensaver should be switched off (e.g., shift start time).  
Only visible if screensaver = Switched daily



**User entry** Time (hh:mm)

**Factory setting** 07:00

---

**Alarm response**



---

<b>Navigation</b>	 Expert → System → Screensaver → Alarm response Direct access code: 160003-000
<b>Description</b>	"Off on alarm": If limit value violations occur or "Maintenance required (Mxxx)" or "Function check (Cxxx)" is active, the screensaver will be automatically deactivated. "Always on": If limit value violations occur, or "Maintenance required (Mxxx)" or "Function check (Cxxx)" is active, the screensaver will not be deactivated.  Active messages that require acknowledgment, as well as "Failure (Fxxx)" or "Out of specification (Sxxx)" events, deactivate the screensaver always.
<b>Options</b>	Off on alarm, Always on
<b>Factory setting</b>	Off on alarm

---

**"Device options" submenu**



---

<b>Navigation</b>	 Expert → System → Device options
<b>Description</b>	Hardware and software options of the device.

---

**Activation code**

---

<b>Navigation</b>	 Expert → System → Device options → Activation code Direct access code: 000057-000
<b>Description</b>	In the input field provided, enter a valid activation code to enable additional device options. The options that can be retrofitted can be found under "spare parts" Note: When an activation code is entered, the device is restarted in order to enable the new option.  <ul style="list-style-type: none"> <li>▪ The activation code entered is not displayed, i.e. this parameter is always empty following a restart.</li> <li>▪ Pay attention to case-sensitivity.</li> </ul>
<b>User entry</b>	Text

---

**Slot 1**

---

<b>Navigation</b>	 Expert → System → Device options → Slot 1 Direct access code: 990000-000
-------------------	---

**Description** Shows hardware/software options.  
Cannot be edited.

 The assignment can be specified in the PC operating software for offline configuration.

**Options** Not assigned, Universal inputs

---

### Slot 2

---

**Navigation**  Expert → System → Device options → Slot 2  
Direct access code: 990001-000

**Description** Shows hardware/software options.  
Cannot be edited.

 The assignment can be specified in the PC operating software for offline configuration.

**Options** Not assigned, Universal inputs

---

### Slot 3

---

**Navigation**  Expert → System → Device options → Slot 3  
Direct access code: 990002-000

**Description** Shows hardware/software options.  
Cannot be edited.

 The assignment can be specified in the PC operating software for offline configuration.

**Options** Not assigned, Universal inputs

---

### Communication

---

**Navigation**  Expert → System → Device options → Communication  
Direct access code: 990006-000

**Description** Shows hardware/software options.  
Cannot be edited.

**Options** USB + Ethernet, USB + Ethernet + RS232/485

---

### Fieldbus

---

**Navigation**  Expert → System → Device options → Fieldbus  
Direct access code: 990005-000

**Description** Shows hardware/software options.  
Cannot be edited.

**Options** Not available, Modbus Slave

---

### Application

---

**Navigation**  Expert → System → Device options → Application  
Direct access code: 990007-000

**Description** Shows hardware/software options.  
Cannot be edited.

**Options** Standard, Maths

### 16.1.2 "Inputs" submenu

Settings for the analog and digital inputs.

---

#### "Universal inputs" submenu

---

**Navigation**  Expert → System → Inputs → Universal inputs

**Description** Settings for the connected measuring points.

---

#### Add input

---

**Navigation**  Expert → System → Inputs → Universal inputs → Add input  
Direct access code: 222000/000

**Description** Addition of an input that must be switched on and configured according to the input signal.

**Options** No, Universal input x

**Factory setting** No

---

#### Delete input

---

**Navigation**  Expert → System → Inputs → Universal inputs → Delete input  
Direct access code: 222001/000

**Description** Delete an input configuration.

**Options** No, Universal input x

**Factory setting** No

---

### "Universal input x" submenu

---

**Navigation**  Expert → System → Inputs → Universal inputs → Universal input x

**Description** View or change settings for the selected channel.

 x = place holder for selected universal input

---

### Signal

---

**Navigation**  Expert → Inputs → Universal inputs → Universal input x → Signal  
Direct access code: 220000-0xx  
Examples: Universal input 1: 220000-000; Universal input 12: 220000-011

**Description** Select the connected signal type (current, voltage, etc.) from the list. The channel remains deactivated if no signal type is selected (factory setting).

**Options** Switched off, Current, Voltage, Resistance thermometer, Thermocouple, Pulse counter, Frequency input, Modbus Slave (option)

**Factory setting** Switched off

---

### Range

---

**Navigation**  Expert → Inputs → Universal inputs → Universal input x → Range  
Direct access code: 220001-0xx  
Examples: Universal input 1: 220001-000; Universal input 12: 220001-011

**Description** Select the input range or the connected resistance thermometer/thermocouple. The terminal assignment is specified in the operating manual or on the rear of the unit. Only visible if signal ≠ Switched off

<b>Options</b>	<p>Switched off</p> <p>Current: 4-20 mA, 0-20 mA, 0-5 mA, 0-20 mA squared, 4-20 mA squared, <math>\pm 20</math> mA</p> <p>Voltage: 0-1 V, 0-10 V, 0-5 V, 1-5 V, <math>\pm 150</math> mV, <math>\pm 1</math> V, <math>\pm 10</math> V, <math>\pm 30</math> V, 0-1 V squared, 0-10 V squared, 1-5 V squared</p> <p>Resistance thermometer: Pt100 (IEC), Pt100 (JIS), Pt100 (GOST), Pt500 (IEC), Pt500 (JIS), Pt1000 (IEC), Pt1000 (JIS), Pt46 (GOST), Pt50 (GOST), Cu50 (GOST, a=4260), Cu50 (GOST, a=4280), Cu53 (GOST, a=4280), Cu100 (GOST, a=4280)</p> <p>Thermocouple: Type A (W5Re-W20Re), type B (Pt30Rh-Pt6Rh), type C (W5Re-W26Re), type D (W3Re-W25Re), type J (Fe-CuNi), type K (NiCr-Ni), type L (Fe-CuNi), type L (NiCr-CuNi, GOST), type N (NiCrSi-NiSi), type R (Pt13Rh-Pt), type S (Pt10Rh-Pt), type T (Cu-CuNi)</p> <p>Pulse counter</p> <p>Frequency input</p> <p>Modbus (option)</p>
----------------	---

**Factory setting** Switched off

---

### Connection

---

**Navigation**  Expert → Inputs → Universal inputs → Universal input x → Connection  
 Direct access code: 220002-0xx  
 Examples: Universal input 1: 220002-000; Universal input 12: 220002-011

**Description** Specify whether the connected resistance thermometer is operated using 2-, 3- or 4-wire technology.  
 Only visible if signal = Resistance thermometer

**Options** 2-wire, 3-wire, 4-wire

**Factory setting** 4-wire

---

### Channel ident.

---

**Navigation**  Expert → Inputs → Universal inputs → Universal input x → Channel ident.  
 Direct access code: 220003-0xx  
 Examples: Universal input 1: 220003-000; Universal input 12: 220003-011

**Description** Name of the measuring point connected to this input.  
 Only visible if signal  $\neq$  Switched off

**User entry** Text (16 characters)

**Factory setting** Channel x

---

### Plot type

---

<b>Navigation</b>	 Expert → Inputs → Universal inputs → Universal input x → Plot type Direct access code: 220016-0xx Examples: Universal input 1: 220016-000; Universal input 12: 220016-011
<b>Description</b>	The analog inputs are scanned in a 100 ms cycle. Depending on the store cycle, the selected data is determined, saved, and displayed based on the scanned values.
<b>Options</b>	Instantaneous value, Average, Minimum value, Maximum value, Minimum + Maximum, Counter, Current value + Counter
<b>Factory setting</b>	Average

---

### Time base

---

<b>Navigation</b>	 Expert → Inputs → Universal inputs → Universal input x → Time base Direct access code: 220025-0xx Examples: Universal input 1: 220025-000; Universal input 12: 220025-011
<b>Description</b>	An instantaneous value can be determined from the counter reading with the aid of the time base, such as input liters, time base = second → instantaneous value = liters/second. Only visible if signal = "Pulse counter" and plot type = "Current value + Counter"
<b>Options</b>	Second (s), Minute (min), Hour (h), Day (d)
<b>Factory setting</b>	Second (s)

---

### Engineering unit

---

<b>Navigation</b>	 Expert → Inputs → Universal inputs → Universal input x → Engineering unit Direct access code: 220004-0xx Examples: Universal input 1: 220004-000; Universal input 12: 220004-011
<b>Description</b>	Specify the technical (physical) unit for the measuring point connected to this input. Only visible if signal ≠ Switched off
<b>User entry</b>	Text (6 characters)

---

### Unit/dimension counter

---

<b>Navigation</b>	 Expert → Inputs → Universal inputs → Universal input x → Unit/dimension counter Direct access code: 220024-00x Examples: Universal input 1: 220024-000; Universal input 12: 220024-011
<b>Description</b>	Technical unit of the count input, e.g., liter, m <sup>3</sup> , etc. Only visible if signal = "Pulse counter" and plot type = "Current value + Counter"

**User entry** Text (max. 6 characters)

---

### Pulse counter

---

**Navigation**  Expert → Inputs → Universal inputs → Universal input x → Pulse counter  
Direct access code: 220017-0xx  
Examples: Universal input 1: 220017-000; Universal input 12: 220017-011

**Description** Specify whether the pulse counter is a fast or slow (up to max. 25 Hz) counter. When recording the number of relay switching operations, select the to 25 Hz setting to ensure correct counting.  
Only visible if signal = Pulse counter

**Options** Up to 13kHz, Up to 25Hz

**Factory setting** Up to 13kHz

---

### Pulse value

---

**Navigation**  Expert → Inputs → Universal inputs → Universal input x → Pulse value  
Direct access code: 220010-0xx  
Examples: Universal input 1: 220010-000; Universal input 12: 220010-011

**Description** Factor, that when multiplied by the input signal results in the required physical value.  
Example: 1 pulse equals 5 m<sup>3</sup> -> enter a "5" here.  
Only visible if signal = Pulse counter

**User entry** Number, max. 8 digits

**Factory setting** 1

---

### Decimal point

---

**Navigation**  Expert → Inputs → Universal inputs → Universal input x → Decimal point  
Direct access code: 220005-0xx  
Examples: Universal input 1: 220005-000; Universal input 12: 220005-011

**Description** Number of places after decimal point for the display.  
Only visible if signal ≠ Switched off

**Options** None, One (X.Y), Two (X.YY), Three (X.YYY), Four (X.YYYY), Five (X.YYYYY)

**Factory setting** One (X.Y)

---

**Lower frequency**



---

<b>Navigation</b>	 Expert → Inputs → Universal inputs → Universal input x → Lower frequency Direct access code: 220018-0xx Examples: Universal input 1: 220018-000; Universal input 12: 220018-011
<b>Description</b>	Configure the lower frequency that corresponds to the start of the measuring range. Only visible if signal = Frequency input
<b>User entry</b>	0 to 12500 (Hz)
<b>Factory setting</b>	5.0 (Hz)

---

**Range start**



---

<b>Navigation</b>	 Expert → Inputs → Universal inputs → Universal input x → Range start Direct access code: 220006-0xx Examples: Universal input 1: 220006-000; Universal input 12: 220006-011
<b>Description</b>	Transmitters convert the physical measured variable to standardized signals. Enter the start of the measuring range.  <ul style="list-style-type: none"> <li>▪ The start and end of the measuring range may not be identical.</li> <li>▪ The start of the measuring range can also be greater than the end (e.g., for deep wells).</li> <li>▪ The parameter can be defined independently of the number of decimal places configured for the measured value as these are only taken into consideration for the display.</li> </ul>
<b>User entry</b>	Number (max. 8 digits)
<b>Factory setting</b>	0 (Depends on the input signal selected)

---

**Upper frequency**



---

<b>Navigation</b>	 Expert → Inputs → Universal inputs → Universal input x → Upper frequency Direct access code: 220019-0xx Examples: Universal input 1: 220019-000; Universal input 12: 220019-011
<b>Description</b>	Configure the upper frequency that corresponds to the upper range limit. Only visible if signal = Frequency input
<b>User entry</b>	0 to 12500 (Hz)
<b>Factory setting</b>	1000.0 (Hz)

---

**Meas. range end**



---

<b>Navigation</b>	 Expert → Inputs → Universal inputs → Universal input x → Meas. range end Direct access code: 220007-0xx Examples: Universal input 1: 220007-000; Universal input 12: 220007-011
<b>Description</b>	<p>Transmitters convert the physical measured variable to standardized signals. Enter the end of the measuring range.</p>  <ul style="list-style-type: none"> <li>▪ The start and end of the measuring range may not be identical.</li> <li>▪ The end of the measuring range can also be smaller than the start (e.g., for deep wells).</li> <li>▪ The parameter can be defined independently of the number of decimal places configured for the measured value as these are only taken into consideration for the display.</li> </ul>
<b>User entry</b>	Number (max. 8 digits)
<b>Factory setting</b>	100 (Depends on the input signal selected)

---

**Zoom start**



---

<b>Navigation</b>	 Expert → Inputs → Universal inputs → Universal input x → Zoom start Direct access code: 220011-0xx Examples: Universal input 1: 220011-000; Universal input 12: 220011-011
<b>Description</b>	<p>If the whole value range is not used, enter the lower value of the required range. The zoom only affects the display and has no influence on data storage.</p>  <ul style="list-style-type: none"> <li>▪ The zoom can also be set outside the measuring range. The only restriction is that the start and end of the zoom may not be identical.</li> <li>▪ If the signal/range is changed, the zoom is corrected if it no longer fits the measuring range.</li> <li>▪ The zoom start can also be larger than the zoom end. The device will automatically rotate the values on the display.</li> </ul>
<b>User entry</b>	Number (max. 8 digits)
<b>Factory setting</b>	0 (Depends on the input signal selected)

---

**Zoom end**

---

<b>Navigation</b>	 Expert → Inputs → Universal inputs → Universal input x → Zoom end Direct access code: 220012-0xx Examples: Universal input 1: 220012-000; Universal input 12: 220012-011
-------------------	--

<b>Description</b>	Like "Zoom start". Enter the upper value of the required range in the input box provided.  <ul style="list-style-type: none"> <li>▪ The zoom can also be set outside the measuring range. The only restriction is that the start and end of the zoom may not be identical.</li> <li>▪ If the signal/range is changed, the zoom is corrected if it no longer fits the measuring range.</li> <li>▪ The zoom end can also be smaller than the zoom start. The device will automatically rotate the values on the display.</li> </ul>
<b>User entry</b>	Number (max. 8 digits)
<b>Factory setting</b>	100 (Depends on the input signal selected)

---

### Damping

---

<b>Navigation</b>	 Expert → Inputs → Universal inputs → Universal input x → Damping Direct access code: 220008-0xx Examples: Universal input 1: 220008-000; Universal input 12: 220008-011
<b>Description</b>	The more unwanted interference there is on the measurement signal the higher the value that should be entered here. Result: Fast changes will be damped/suppressed. Only visible if signal = Current, Voltage, Resistance thermometer or Thermocouple
<b>User entry</b>	0 to 999.9 s
<b>Factory setting</b>	Current, voltage: 0.0 s Resistance thermometer, thermocouple: 0.2 s

---

### Comparison point

---

<b>Navigation</b>	 Expert → Inputs → Universal inputs → Universal input x → Comparison point Direct access code: 220013-0xx Examples: Universal input 1: 220013-000; Universal input 12: 220013-011
<b>Description</b>	Internal: Compensation of the voltage error by measuring the terminal temperature. External: Compensation of the voltage error by using an external controlled comparison measurement point. Only visible if signal = Thermocouple
<b>Options</b>	Internal, External
<b>Factory setting</b>	Internal

---

### Comparison temp.

---

<b>Navigation</b>	 Expert → Inputs → Universal inputs → Universal input x → Comparison temp. Direct access code: 220014-0xx Examples: Universal input 1: 220014-000; Universal input 12: 220014-011
<b>Description</b>	Settings for the external comparison temperature (only when connecting thermocouples). Only visible if comparison point = External
<b>User entry</b>	0 to 9999999 (Depends on the temperature unit selected)
<b>Factory setting</b>	0 (Depends on the temperature unit selected)

---

### Totalizer

---

<b>Navigation</b>	 Expert → Inputs → Universal inputs → Universal input x → Totalizer Direct access code: 220015-0xx Examples: Universal input 1: 220015-000; Universal input 12: 220015-011
<b>Description</b>	Initial setting for the totalizer. Useful when continuing measurements recorded to date with an (electro)-mechanical counter. Only visible if signal = Pulse counter
<b>User entry</b>	Number (max. 15 digits)
<b>Factory setting</b>	0

---

### "Meas.val. corrct." submenu

---

<b>Navigation</b>	 Expert → Inputs → Universal inputs → Universal input x → Meas.val. corrct.
<b>Description</b>	Determining the correction values to balance measurement tolerances. <b>Proceed as follows:</b> <ul style="list-style-type: none"> <li>■ Measure the current value at the lower measuring range.</li> <li>■ Measure the current value at the upper measuring range.</li> <li>■ Enter the lower and upper target and actual values in each case.</li> </ul>

---

### Offset

---

<b>Navigation</b>	 Expert → Inputs → Universal inputs → Universal input x → Meas.val. corrct. → Offset Direct access code: 220050-0xx Examples: Universal input 1: 220050-000; Universal input 12: 220050-011
<b>Description</b>	The set value is added to the actual measured input signal for further use (display, storage, set point monitoring). Only visible if signal = Resistance thermometer or Thermocouple
<b>User entry</b>	Number (max. 8 digits)

**Factory setting** 0

---

### Correction RPT

---

**Navigation**  Expert → Inputs → Universal inputs → Universal input x → Meas.val. corrct. → Correction RPT  
 Direct access code: 220057-0xx  
 Examples: Universal input 1: 220057-000; Universal input 12: 220057-011

**Description** Rear panel temperature correction value for this analog input (only required for thermocouples).

 Only visible/editable if the service code has been entered.

**User entry** Number (max. 8 digits)

**Factory setting** -3.0 for slot 1+2  
 -3.2 for slot 3

---

### Range start

---



---

### Target value

---

**Navigation**  Expert → Inputs → Universal inputs → Universal input x → Meas.val. corrct. → Target value  
 Direct access code: 220052-0xx  
 Examples: Universal input 1: 220052-000; Universal input 12: 220052-011

**Description** Enter the lower set point (example: measuring range 0 to 100 °C: 0 °C).  
 Only visible if signal = Current or Voltage

**User entry** Number (max. 8 digits)

**Factory setting** 0

---

### Actual value

---

**Navigation**  Expert → Inputs → Universal inputs → Universal input x → Meas.val. corrct. → Actual value  
 Direct access code: 220053-0xx  
 Examples: Universal input 1: 220053-000; Universal input 12: 220053-011

**Description** Enter the lower value actually measured (example: measuring range 0 to 100 °C: 0.5 °C measured).  
Only visible if signal = Current or Voltage

**User entry** Number (max. 8 digits)

**Factory setting** 0

---

### Meas. range end

---



---

### Target value

---

**Navigation**  Expert → Inputs → Universal inputs → Universal input x → Meas.val. corrct. → Target value  
Direct access code: 220055-0xx  
Examples: Universal input 1: 220055-000; Universal input 12: 220055-011

**Description** Enter the upper set point (example: measuring range 0 to 100 °C: 100 °C).  
Only visible if signal = Current or Voltage

**User entry** Number (max. 8 digits)

**Factory setting** 100

---

### Actual value

---

**Navigation**  Expert → Inputs → Universal inputs → Universal input x → Meas.val. corrct. → Actual value  
Direct access code: 220056-0xx  
Examples: Universal input 1: 220056-000; Universal input 12: 220056-011

**Description** Enter the upper value actually measured (example: measuring range 0 to 100 °C: 100.5 °C measured).  
Only visible if signal = Current or Voltage

**User entry** Number (max. 8 digits)

**Factory setting** 100

---

### "Totalization" submenu

---

**Navigation**  Expert → Inputs → Universal inputs → Universal input x → Totalization

**Description** Settings are only required if this analog measuring point is to be used for totalization (e.g., for flow calculation).

---

**Totalization**



---

<b>Navigation</b>	 Expert → Inputs → Universal inputs → Universal input x → Totalization → Totalization Direct access code: 220030-0xx Examples: Universal input 1: 220030-000; Universal input 12: 220030-011
<b>Description</b>	By totalizing the analog signal (e.g., flow rate in m <sup>3</sup> /h), quantities (in m <sup>3</sup> ) can be calculated.
<b>Options</b>	No, Yes
<b>Factory setting</b>	No

---

**Totalization base**



---

<b>Navigation</b>	 Expert → Inputs → Universal inputs → Universal input x → Totalization → Totalization base Direct access code: 220031-0xx Examples: Universal input 1: 220031-000; Universal input 12: 220031-011
<b>Description</b>	Select the required time base. Example: ml/s -> time base seconds (s); m <sup>3</sup> /h -> time base hours (h). Only visible if totalization = Yes
<b>Options</b>	Second (s), Minute (min), Hour (h), Day (d)
<b>Factory setting</b>	Second (s)

---

**Unit**



---

<b>Navigation</b>	 Expert → Inputs → Universal inputs → Universal input x → Totalization → Unit Direct access code: 220032-0xx Examples: Universal input 1: 220032-000; Universal input 12: 220032-011
<b>Description</b>	Enter the unit for the quantity calculated by totalization (e.g., "m <sup>3</sup> "). Only visible if totalization = Yes
<b>User entry</b>	Text (max. 6 characters)

---

**Low flow cut off**



---

<b>Navigation</b>	 Expert → Inputs → Universal inputs → Universal input x → Totalization → Low flow cut off Direct access code: 220033-0xx Examples: Universal input 1: 220033-000; Universal input 12: 220033-011
<b>Description</b>	If the volume flow recorded is below the set value, these quantities are not added to the counter. If the input is scaled from 0 to y, or if the pulse input is used, all values that are smaller than the set value are not recorded. If the input is scaled from -x to +y, all values around the zero point (i.e., also negative values) are not recorded. Only visible if totalization = Yes
<b>User entry</b>	Number (max. 8 digits)
<b>Factory setting</b>	0

---

**Calc. factor**



---

<b>Navigation</b>	 Expert → Inputs → Universal inputs → Universal input x → Totalization → Calc. factor Direct access code: 220034-0xx Examples: Universal input 1: 220034-000; Universal input 12: 220034-011
<b>Description</b>	Factor for calculating the integrated value (e.g., the transmitter delivers l/s -> totalization base = second -> engineering unit required is m <sup>3</sup> -> enter factor 0.001) Only visible if totalization = Yes
<b>User entry</b>	Number (max. 8 digits)
<b>Factory setting</b>	1.0

---

**Totalizer**



---

<b>Navigation</b>	 Expert → Inputs → Universal inputs → Universal input x → Totalization → Totalizer Direct access code: 220035-0xx Examples: Universal input 1: 220035-000; Universal input 12: 220035-011
<b>Description</b>	Initial setting for the totalizer. Useful when continuing measurements recorded to date with an (electro)-mechanical counter. Only visible if totalization = Yes
<b>User entry</b>	Number (max. 15 digits)
<b>Factory setting</b>	0

---

**"Fault mode" submenu**

---

 In the event of an error the alarm relay is switched if so configured →  85

**Navigation**

 Expert → Inputs → Universal inputs → Universal input x → Fault mode

**Description**

Contains settings that define how this channel responds under fault conditions (e.g., cable open circuit, overrange).

---

**NAMUR NE 43**

---

**Navigation**

 Expert → Inputs → Universal inputs → Universal input x → Fault mode → NAMUR NE 43  
Direct access code: 220060-0xx  
Examples: Universal input 1: 220060-000; Universal input 12: 220060-011

**Description**

Activate/deactivate the 4–20mA loop monitoring as per NAMUR recommendation NE 43. The following error ranges apply when NAMUR NE 43 is switched on:  
≤ 3.8 mA: under range  
≥ 20.5 mA: overrange  
≤ 3.6 mA or ≥ 21.0 mA: sensor error  
≤ 2 mA: cable open circuit  
Only visible if signal = "Current" and range = "4-20 mA" or "4-20 mA squared".

**Options**

Off, On

**Factory setting**

On

---

**Cable open circuit**

---

**Navigation**

 Expert → Inputs → Universal inputs → Universal input x → Fault mode → Cable open circuit  
Direct access code: 220060-0xx  
Examples: Universal input 1: 220060-000; Universal input 12: 220060-011

**Description**

Cable open circuit detection  
Only visible if signal = "Voltage" and range = "1-5 V" or "1-5 V squared".

**Options**

Off, On

**Factory setting**

On

---

**Lower error value**

---

<b>Navigation</b>	 Expert → Inputs → Universal inputs → Universal input x → Fault mode → Lower error value Direct access code: 220065-0xx Examples: Universal input 1: 220065-000; Universal input 12: 220065-011
<b>Description</b>	When NE 43 is switched off, defines the value that must be undershot for the device to output an error. Only visible if signal = "Current", range = "4-20 mA" and NAMUR NE 43 = "Off"
<b>User entry</b>	Number (max. 8 digits); 0 to 4 mA
<b>Factory setting</b>	3.9mA

---

### Upper error value

---

<b>Navigation</b>	 Expert → Inputs → Universal inputs → Universal input x → Fault mode → Upper error value Direct access code: 220066-0xx Examples: Universal input 1: 220066-000; Universal input 12: 220066-011
<b>Description</b>	When NE 43 is switched off, defines the value that must be exceeded for the device to output an error. Only visible if signal = "Current", range = "4-20 mA" and NAMUR NE 43 = "Off"
<b>User entry</b>	Number (max. 8 digits); 20 to 22mA
<b>Factory setting</b>	20.8mA

---

### Time delay

---

<b>Navigation</b>	 Expert → Inputs → Universal inputs → Universal input x → Fault mode → Time delay Direct access code: 220064-0xx Examples: Universal input 1: 220064-000; Universal input 12: 220064-011
<b>Description</b>	The device does not respond (e.g., with the switching of a relay) to a cable open circuit/ underrange/overrange until this state has been active for the preset time as a minimum. Only visible if NAMUR NE 43 = On
<b>User entry</b>	0 to 99 s
<b>Factory setting</b>	0s

---

### On error

---

**Navigation**  Expert → Inputs → Universal inputs → Universal input x → Fault mode → On error  
Direct access code: 220061-0xx  
Examples: Universal input 1: 220061-000; Universal input 12: 220061-011

**Description** Configure which value the device should continue working with (for calculations) if the measured value is not valid (e.g., cable open circuit).  
 In the event of an error value, all the dependent calculations are flagged accordingly as "error value". Counters are not flagged, however!

**Options** Invalid calculation, Error value

**Factory setting** Invalid calculation

---

### Error value

---

**Navigation**  Expert → Inputs → Universal inputs → Universal input x → Fault mode → Error value  
Direct access code: 220062-0xx  
Examples: Universal input 1: 220062-000; Universal input 12: 220062-011

**Description** The device continues calculating with this value in the event of an error.  
Only visible if on error = Error value

**User entry** Number (max. 8 digits)

**Factory setting** 0

---

### Save event

---

**Navigation**  Expert → Inputs → Universal inputs → Universal input x → Fault mode → Save event  
Direct access code: 220063-0xx  
Examples: Universal input 1: 220063-000; Universal input 12: 220063-011

**Description** Stores a message in the event logbook when a fault occurs.

**Options** No, Yes

**Factory setting** No

---

### Copy settings

---

**Navigation**  Expert → Inputs → Universal inputs → Universal input x → Copy settings  
Direct access code: 220200-0xx  
Examples: Universal input 1: 220200-000; Universal input 12: 220200-011

**Description** Copies settings from actual channel to selected channel.

**Options** Switched off, Universal input x  
Users can choose from all the available universal inputs.

**Factory setting** Switched off

---

### "Digital inputs -> Digital input x" submenu

---

**Navigation**  Expert → Inputs → Digital inputs → Digital input x

**Description** Settings only required if digital inputs (e.g., events) are to be used.

 x = place holder for selected digital input

---

### Add input

---

**Navigation**  Expert → System → Digital inputs → Add input  
Direct access code: 252000/000

**Description** Addition of a digital input that must be configured according to the function.

**Options** No, Digital input x

**Factory setting** No

---

### Delete input

---

**Navigation**  Expert → System → Digital inputs → Delete input  
Direct access code: 252001/000

**Description** Delete an input configuration.

**Options** No, Digital input x

**Factory setting** No

---

### Function

---

**Navigation**  Expert → Inputs → Digital inputs → Digital input x → Function  
Direct access code: 250000-00x  
Examples: Digital input 1: 250000-000; Digital input 6: 250000-005

**Description** Select the required function. Digital inputs are High active; this means the described effect is achieved by a high input.  
Low = -3 to +5 V  
High = +12 to +30 V

**Options** Switched off, Control input, On/off event, Pulse counter, Operational time, Event +operation time, Quantity from time, Modbus Slave (option)

**Factory setting** Switched off

---

## Function

---

**Navigation**  Expert → Inputs → Digital inputs → Digital input x → Function  
Direct access code: 250014-00x  
Examples: Digital input 1: 250014-000; Digital input 6: 250014-005

**Description** Specifies how the data from the fieldbus is interpreted/processed.  
Only visible if function = Modbus Slave

**Options** Switched off, Control input, On/off event, Pulse counter, Operational time, Event +operation time, Quantity from time

**Factory setting** Switched off

---

## Channel ident.

---

**Navigation**  Expert → Inputs → Digital inputs → Digital input x → Channel ident.  
Direct access code: 250001-00x  
Examples: Digital input 1: 250001-000; Digital input 6: 250001-005

**Description** Measuring point name (e.g., "Pump") or description of the function performed with this input (e.g., "Fault message").  
Only visible if function ≠ Switched off

**User entry** Text (max. 16 characters)

**Factory setting** Digital x

---

## Engineering unit

---

**Navigation**  Expert → Inputs → Digital inputs → Digital input x → Engineering unit  
Direct access code: 250002-00x  
Examples: Digital input 1: 250002-000; Digital input 6: 250002-005

**Description** Technical unit of the count input, e.g., liter, m<sup>3</sup>, etc.  
Only visible if function = Pulse counter or Quantity from time

**User entry** Text (max. 6 characters)

---

### Decimal point

---

**Navigation**  Expert → Inputs → Digital inputs → Digital input x → Decimal point  
Direct access code: 250004-00x  
Examples: Digital input 1: 250004-000; Digital input 6: 250004-005

**Description** Number of places after decimal point for the display.  
Only visible if function = Pulse counter or Quantity from time

**Options** None, One (X.Y), Two (X.YY), Three (X.YYY), Four (X.YYYY), Five (X.YYYYY)

**Factory setting** One (X.Y)

---

### Input factor in

---

**Navigation**  Expert → Inputs → Digital inputs → Digital input x → Input factor in  
Direct access code: 250019-00x  
Examples: Digital input 1: 250019-000; Digital input 6: 250019-005

**Description** Defines if the set up factor is respective to 1 second or 1 hour.  
Only visible if function = Quantity from time

**Options** Seconds, Hours

**Factory setting** Seconds

---

### Pulse value

---

**Navigation**  Expert → Inputs → Digital inputs → Digital input x → Pulse value  
Direct access code: 250005-00x  
Examples: Digital input 1: 250005-000; Digital input 6: 250005-005

**Description** Factor, that when multiplied by the input signal results in the required physical value.  
Examples:  
1 pulse equals 5 m<sup>3</sup>-> enter "5" here.  
Only visible if function = Pulse counter

**User entry** Number (max. 8 digits)

**Factory setting** 1

---

**1 second=/1 hour=** (depends on the setting in "Input factor in")

---

**Navigation**  Expert → Inputs → Digital inputs → Digital input x → 1 second= / 1 hour=  
Direct access code: 250005-00x  
Examples: Digital input 1: 250005-000; Digital input 6: 250005-005

**Description** Factor, that when multiplied by the operating time results in the required physical value.  
Examples:  
1 second equals 8 l -> enter "8" here.  
Only visible if function = Quantity from time

**User entry** Number (max. 8 digits)

**Factory setting** 1

---

### Time delay

---

**Navigation**  Expert → Inputs → Digital inputs → Digital input x → Time delay  
Direct access code: 250017-00x  
Examples: Digital input 1: 250017-000; Digital input 6: 250017-005

**Description** The high signal must be active for at least the preset time before the device changes the channel from low to high.  
The change from high to low is always immediate.  
Only visible if function = Control input, On/off event, Event+operation time

**User entry** 0 to 99 999 s

**Factory setting** 0

---

### Action

---

**Navigation**  Expert → Inputs → Digital inputs → Digital input x → Action  
Direct access code: 250003-00x  
Examples: Digital input 1: 250003-000; Digital input 6: 250003-005

**Description** Set up the function of the control input.  
Only visible if function = Control input

Action	Description
Start/stop recording	The device only saves data as long as a high signal is present
Screensaver on	Switches backlighting/display off, low = off, high = on
Lock setup	The user can only change the setup if a low signal is present
Time synchronization	If a high signal is applied, the device rounds the system time up or down (only for Low→ High change): 0 to 29 → round down; 30 to 59 → round up

Action	Description
Set point monitoring on/off	The entire set point monitoring function of the device can be switched on (for "High") or switched off (for "Low").
Block keyboard/navigator	The device can only be operated if a low signal is present. Otherwise, all key activation and navigator actions are discarded.
Start/stop analysis 1	Starts/ends the external analysis (the analysis only runs as long as the signal is high). Measured value acquisition for the graphic display continues.

**Options** Switched off, Start/stop recording, Screensaver on, Lock setup, Time synchronization, Set point monitoring on/off, Block keyboard/navigator, Start/stop analysis 1

**Factory setting** Switched off

---

**Switches relay**

---

**Navigation**  Expert → Inputs → Digital inputs → Digital input x → Switches relay  
 Direct access code: 250006-00x  
 Examples: Digital input 1: 250006-000; Digital input 6: 250006-005

**Description** Switches the corresponding relay when the digital input is low or high. Follow the connection instructions in the user manual!  
 Only visible if function = Control input, On/off event, Event+operation time

**Options** Not used, Relay x  
 All the available relays are displayed.

**Factory setting** Not used

---

**Description 'H'**

---

**Navigation**  Expert → Inputs → Digital inputs → Digital input x → Description 'H'  
 Direct access code: 250007-00x  
 Examples: Digital input 1: 250007-000; Digital input 6: 250007-005

**Description** Condition description when the digital input is active. This text is shown on the display and saved to memory.  
 Only visible if function = Control input, On/off event, Event+operation time

**User entry** Text (max. 6 characters)

**Factory setting** On

---

**Description 'L'**



---

<b>Navigation</b>	 Expert → Inputs → Digital inputs → Digital input x → Description 'L' Direct access code: 250008-00x Examples: Digital input 1: 250008-000; Digital input 6: 250008-005
<b>Description</b>	Condition description when the digital input is not active. This text is shown on the display and saved to memory. Only visible if function = Control input, On/off event, Event+operation time
<b>User entry</b>	Text (max. 6 characters)
<b>Factory setting</b>	Off

---

### Save event

---

<b>Navigation</b>	 Expert → Inputs → Digital inputs → Digital input x → Save event Direct access code: 250009-00x Examples: Digital input 1: 250009-000; Digital input 6: 250009-005
<b>Description</b>	Determines whether the condition change from low to high or high to low is stored in the event logbook.  Requires higher memory capacity. Only visible if function = Control input, On/off event, Event+operation time
<b>Options</b>	No, Yes, only "On" message
<b>Factory setting</b>	Yes

---

### Event message



---

<b>Navigation</b>	 Expert → Inputs → Digital inputs → Digital input x → Event message Direct access code: 250018-00x Examples: Digital input 1: 250018-000; Digital input 6: 250018-005
<b>Description</b>	"Do not acknowledge": No message is shown if the digital input switches. "Acknowledge": A message window is shown on the screen which has to be acknowledged by operating a push button. Only visible if function = Control input, On/off event, Event+operation time
<b>Options</b>	Do not acknowledge, Acknowledge
<b>Factory setting</b>	Do not acknowledge

---

### Event text L->H



---

<b>Navigation</b>	 Expert → Inputs → Digital inputs → Digital input x → Event text L->H Direct access code: 250010-00x Examples: Digital input 1: 250010-000; Digital input 6: 250010-005
<b>Description</b>	Description of condition change from low to high. Event text is stored (e.g., start filling).  If no event text has been configured, the device automatically generates an event text (factory setting), e.g., Digital 1 L->H. Only visible if function = Control input, On/off event, Event+operation time
<b>User entry</b>	Text (max. 22 characters)

---

**Event text H->L**



---

<b>Navigation</b>	 Expert → Inputs → Digital inputs → Digital input x → Event text H->L Direct access code: 250011-00x Examples: Digital input 1: 250011-000; Digital input 6: 250011-005
<b>Description</b>	Description of condition change from high to low. Event text is stored (e.g., stop filling).  If no event text has been configured, the device automatically generates an event text (factory setting), e.g., Digital 1 H->L. Only visible if function = Control input, On/off event, Event+operation time
<b>User entry</b>	Text (max. 22 characters)

---

**Record duration**



---

<b>Navigation</b>	 Expert → Inputs → Digital inputs → Digital input x → Record duration Direct access code: 250012-00x Examples: Digital input 1: 250012-000; Digital input 6: 250012-005
<b>Description</b>	The duration between "On" and "Off" can be recorded. The duration is appended to the "Off" event text (<hhhh>h<mm>:<ss>). Power failure times do not affect the duration. If the digital channel was "on" before the power failure and is still "on" after the power failure, the duration continues. Only visible if function = Control input, On/off event, Event+operation time
<b>Options</b>	No, Yes
<b>Factory setting</b>	No

---

**Totalizer**

---

<b>Navigation</b>	 Expert → Inputs → Digital inputs → Digital input x → Totalizer Direct access code: 250013-00x Examples: Digital input 1: 250013-000; Digital input 6: 250013-005
-------------------	--

<b>Description</b>	Initial setting for the totalizer. Useful when continuing measurements recorded to date with an (electro)-mechanical counter. Only visible if function = Pulse counter, Operational time, Event+operation time or Quantity from time
<b>User entry</b>	Number (max. 15 digits)
<b>Factory setting</b>	0

---

### Copy settings

---

<b>Navigation</b>	 Expert → Inputs → Digital inputs → Digital input x → Copy settings Direct access code: 250200-00x Examples: Digital input 1: 250200-000; Digital input 6: 250200-005
<b>Description</b>	Copies settings from actual channel to selected channel.
<b>Options</b>	No, Digital input x Users can choose from all the available digital inputs.
<b>Factory setting</b>	No



### 16.1.3 "Outputs" submenu

Settings only required if outputs (e.g., relays) are to be used.

---

### "Relay x" submenu

---

<b>Navigation</b>	 Expert → Outputs → Relay x
<b>Description</b>	Contains settings for the selected relay  x = place holder for selected relay

---

### Operating mode

---

<b>Navigation</b>	 Expert → Outputs → Relay x → Operating mode Direct access code: 330000-00x Examples: Relay 1:330000-000; Relay 6: 330000-005
<b>Description</b>	Relay function: NC contact: The relay is closed in its quiescent state (maximum safety). NO contact: The relay is open in its quiescent state.
<b>Options</b>	NO contact, NC contact
<b>Factory setting</b>	NO contact

---

**Identifier**

---

<b>Navigation</b>	 Expert → Outputs → Relay x → Identifier Direct access code: 330001-00x Examples: Relay 1:330001-000; Relay 6: 330001-005
<b>Description</b>	User-configurable relay identifier.
<b>User entry</b>	Text (max. 16 characters)
<b>Factory setting</b>	Relay x

### 16.1.4 “Communication” submenu

Settings required if the USB, RS232, RS485 or Ethernet interface of the device is used (PC operation, serial data read-out, modem operation, etc.).

 The various interfaces can be operated in parallel.

---

**Timeout cycl. readout**



---

<b>Navigation</b>	 Expert → Communication → Timeout Direct access code: 150200-000
<b>Description</b>	Monitors whether measured values are read out cyclically via OPC or Fieldbus. Timeout is modifiable between 1 and 99 seconds. 0 seconds means that the functionality is inactivated.
<b>User entry</b>	0 to 99 s
<b>Factory setting</b>	0 s

---

**Switches**



---

<b>Navigation</b>	 Expert → Communication → Switches Direct access code: 150201-000
<b>Description</b>	After the given timeout the dedicated relay/OC is active while no readout of actual measured values are in process.
<b>Options</b>	Not used, Relay x All the available relays are displayed.
<b>Factory setting</b>	Not used

---

**Timeout fieldbus**



---

<b>Navigation</b>	 Expert → Communication → Timeout fieldbus Direct access code: 150210-000
<b>Description</b>	Time within which measured values must be received via fieldbus (otherwise, an error will be set). Not relevant if only measured values are read out.
<b>User entry</b>	1 to 99 s
<b>Factory setting</b>	10 s

---

**Function USB-B**



---

<b>Navigation</b>	 Expert → Communication → Function USB-B Direct access code: 012001-000
<b>Description</b>	Determines the operating mode of the USB interface if a cable is connected to the device.
<b>Options</b>	Always USB Always Ethernet over USB By user input
<b>Factory setting</b>	Always USB

---

**"Ethernet" submenu**



---

<b>Navigation</b>	 Expert → Communication → Ethernet
<b>Description</b>	Contains settings required when using the device's Ethernet interface.

---

**MAC address**

---

<b>Navigation</b>	 Expert → Communication → Ethernet → MAC address Direct access code: 150000-000
<b>Description</b>	Displays the MAC address

---

**DHCP**

---

<b>Navigation</b>	 Expert → Communication → Ethernet → DHCP Direct access code: 150002-000
-------------------	--

<b>Description</b>	The device can get its Ethernet settings through DHCP. Caution: The settings determined are not displayed until after setup acceptance!  Note: The unit always gets the same IP address if the leasing time is set long enough on the DHCP server. The PC software needs the IP address determined to establish a connection!
<b>Options</b>	No, Yes
<b>Factory setting</b>	Yes

---

### IP address

---

<b>Navigation</b>	 Expert → Communication → Ethernet → IP address Direct access code: 150003-000
<b>Description</b>	Enter the IP address for the device. This is assigned by the network administrator. Contact your administrator if you have any questions Can only be edited if DHCP = No
<b>User entry</b>	IP address
<b>Factory setting</b>	000.000.000.000

---

### Subnetmask

---

<b>Navigation</b>	 Expert → Communication → Ethernet → Subnetmask Direct access code: 150004-000
<b>Description</b>	Enter the subnetmask (provided by the network administrator). Can only be edited if DHCP = No
<b>User entry</b>	IP address
<b>Factory setting</b>	255.255.255.000

---

### Gateway

---

<b>Navigation</b>	 Expert → Communication → Ethernet → Gateway Direct access code: 150005-000
<b>Description</b>	Enter the gateway (provided by the network administrator). Can only be edited if DHCP = No
<b>User entry</b>	IP address

**Factory setting** 000.000.000.000

---

### Domain Name System (DNS)

---

**Navigation**  Expert → Communication → Ethernet → Domain Name System (DNS)  
Direct access code: 150009-000

**Description** Enter the IP address of a DNS server (provided by the network administrator).  
Needed if you wish to use the name of the email server (e.g., smtp.example.org) instead of the IP address, for example, to send emails  
Can only be edited if DHCP = No

**User entry** IP address

**Factory setting** 000.000.000.000

---

### Disable port

---

**Navigation**  Expert → Communication → Ethernet → Disable port  
Direct access code: 150020-000

**Description** Ports that are not needed can be switched off for security reasons.  
CDI is the protocol that the configuration software/analysis software uses to communicate with the device.  
 All other ports (SNTP, SMTP, web server) are automatically disabled if the function is switched off.

**Options** CDI, OPC, Modbus Slave  
F

**Factory setting** ---- (no port disabled)

---

### Port

---

**Navigation**  Expert → Communication → Ethernet → Port  
Direct access code: 150001-000

**Description** The system communicates with the PC software through this communication port.  
 If the network is protected by a firewall, this port may have to be enabled. In this case, contact the network administrator.



**User entry** Number (max. 5 digits)

**Factory setting** 8000

---

**OPC port**



---

<b>Navigation</b>	 Expert → Communication → Ethernet → OPC port Direct access code: 150010-000
<b>Description</b>	Values can be read via OPC server using this communication port.  If the network is protected by a firewall, this port may have to be enabled. In this case, contact the network administrator.
<b>User entry</b>	Number (max. 5 digits)
<b>Factory setting</b>	8002

---

**Web server**



---

<b>Navigation</b>	 Expert → Communication → Ethernet → Web server Direct access code: 470000-000
<b>Description</b>	Enable or disable the web server function. The instantaneous values can only be displayed using an Internet browser when the web server is activated.  It is only possible to connect to the web server via the Ethernet interface!
<b>Options</b>	No (web server is off), Yes (web server is active)
<b>Factory setting</b>	Yes

---

**"Configuration Web server" submenu**



---

<b>Navigation</b>	 Expert → Communication → Ethernet → Configuration Web server
<b>Description</b>	Configure the web server or specify which functionality should be possible via the web server. Only visible if web server = Yes.  Instantaneous value display is always possible once the web server is switched on.

---

**Port**

---

<b>Navigation</b>	 Expert → Communication → Ethernet → Configuration Web server → Port Direct access code: 470003-000
<b>Description</b>	The web server communicates through this communication port.  If the network is protected by a firewall, this port may have to be enabled. In this case, contact the network administrator.

**User entry**                      Number (max. 5 digits)

**Factory setting**                80

---

### Setup

---

**Navigation**                          Expert → Communication → Ethernet → Configuration Web server → Setup  
Direct access code: 470001-000

**Description**                      The device can be configured via the web server.  
For security reasons it is advisable to switch off configuration via the web server after commissioning.  
Contact the network administrator for questions related to IT security.

**Options**                            No, Yes

**Factory setting**                Yes

---

### Firmware update

---

**Navigation**                          Expert → Communication → Ethernet → Configuration Web server → Firmware update  
Direct access code: 470002-000

**Description**                      Firmware can be updated via the web server.

**Options**                            No, Yes

**Factory setting**                No

---

### Remote control

---

**Navigation**                          Expert → Communication → Ethernet → Configuration Web server → Remote control  
Direct access code: 470004-000

**Description**                      The device can be remote-controlled via the web server.

**Options**                            No, Yes

**Factory setting**                No

---

### WebDAV server

---

<b>Navigation</b>	 Expert → Communication → Ethernet → Configuration Web server → WebDAV server Direct access code: 470006-000
<b>Description</b>	The SD card can be read out via the WebDAV client.
<b>Options</b>	No, Yes
<b>Factory setting</b>	No

**Meas. val. without login**

<b>Navigation</b>	 Expert → Communication → Ethernet → Configuration Web server → Meas. val. without login Direct access code: 470009-000
<b>Description</b>	Allow access to current measured values without logging in. URL: http:\\<ip>\liv
<b>Options</b>	Yes, No
<b>Factory setting</b>	Yes

**"Authentication" submenu**

**Navigation**  Expert → Communication → Ethernet → Configuration Web server → Authentication

**Description** Set the passwords for the different users who can access the device via the web server.

	Operator	Admin	Service
Measured value display	Yes	Yes	Yes
Display instrument health status	Yes	Yes	Yes
Configuration	No	Yes	Yes
Configuration incl. service parameter	No	No	Yes
Update firmware	No	Yes	Yes
WebDAV	Yes	Yes	Yes

 Change the following passwords during commissioning.

**Operator**

**ID**

---

**Navigation**  Expert → Communication → Ethernet → Configuration Web server → Authentication → ID  
Direct access code: 470104-000

**Description** ID required in order to access the device. Pay attention to case-sensitivity.  
Cannot be edited.

**Factory setting** operator

---

### Password

---

**Navigation**  Expert → Communication → Ethernet → Configuration Web server → Authentication → Password  
Direct access code: 470105-000

**Description** Enter the password for this user account.  
Pay attention to case-sensitivity.

**User entry** Text (max. 12 characters)

**Factory setting** operator

---

### Administrator

---



---

### ID

---

**Navigation**  Expert → Communication → Ethernet → Configuration Web server → Authentication → ID  
Direct access code: 470101-000

**Description** ID required in order to access the device. Pay attention to case-sensitivity.  
Cannot be edited.

**Factory setting** admin

---

### Password

---

**Navigation**  Expert → Communication → Ethernet → Configuration Web server → Authentication → Password  
Direct access code: 470102-000

**Description** Enter the password for this user account.  
Pay attention to case-sensitivity.

**User entry** Text (max. 12 characters)

**Factory setting** admin

---

### Service

---



---

### ID

---

**Navigation**  Expert → Communication → Ethernet → Configuration Web server → Authentication → ID  
Direct access code: 470107-000

**Description** ID required in order to access the device. Pay attention to case-sensitivity  
Cannot be edited.

**Factory setting** service

---

### Password

---

**Navigation**  Expert → Communication → Ethernet → Configuration Web server → Authentication → Password  
Direct access code: 470108-000

**Description** Enter the password for this user account.  
Pay attention to case-sensitivity.

**User entry** Text (max. 12 characters)

**Factory setting** service

---

### "Timeouts" submenu

---

**Navigation**  Expert → Communication → Ethernet → Configuration Web server → Timeouts

**Description** Timeouts for the web server. Only change settings if slow network connections are causing transmission problems.

 The settings are only adopted if the browser has been restarted or a new tab opened.  
Caution: Settings should only be changed by experts.

---

### Connection quality

---

**Navigation**  Expert → Communication → Ethernet → Configuration Web server → Timeouts → Connection quality  
Direct access code: 470200-000

**Description** Configuration of typical timeout values for the web server connection.

 The default values can be changed if necessary.

**Options** Please select, Local network (LAN/WLAN), Wireless/mobile (fast connect.), Wireless/mobile (slow connect)

**Factory setting** Please select

---

#### Get timeout

---

**Navigation**  Expert → Communication → Ethernet → Configuration Web server → Timeouts → Get timeout  
Direct access code: 470201-000

**Description** Maximum time to load a new page before the browser ends the connection.

**User entry** 5 to 999 s

**Factory setting** 25

---

#### Set timeout

---

**Navigation**  Expert → Communication → Ethernet → Configuration Web server → Timeouts → Set timeout  
Direct access code: 470202-000

**Description** Maximum time to write a value or execute an action before the browser ends the connection.

**User entry** 5 to 999 s

**Factory setting** 5

---

#### Put timeout

---

**Navigation**  Expert → Communication → Ethernet → Configuration Web server → Timeouts → Put timeout  
Direct access code: 470203-000

**Description** Maximum time to transmit files to or from the device before the browser ends the connection.

**User entry** 5 to 999 s

**Factory setting** 240

---

### Ping interval

---

**Navigation**  Expert → Communication → Ethernet → Configuration Web server → Timeouts → Ping interval  
Direct access code: 470204-000

**Description** Interval in which the browser checks device reachability.  
 The check is switched off if 0 s is set. This is for diagnostic purposes only and should not be set!

**User entry** 0 to 999 s

**Factory setting** 10

---

### Ping timeout

---

**Navigation**  Expert → Communication → Ethernet → Configuration Web server → Timeouts → Ping timeout  
Direct access code: 470205-000

**Description** Time in which the device must respond before the browser ends the connection.

**User entry** 5 to 99 s

**Factory setting** 15

---

### Ping retry

---

**Navigation**  Expert → Communication → Ethernet → Configuration Web server → Timeouts → Ping retry  
Direct access code: 470206-000

**Description** Number of retries if the device does not respond.

**User entry** 0 to 5

**Factory setting** 0

---

### Poll timeout

---

<b>Navigation</b>	 Expert → Communication → Ethernet → Configuration Web server → Timeouts → Poll timeout Direct access code: 470207-000
<b>Description</b>	Maximum permitted time to refresh the website.
<b>User entry</b>	5 to 99 s
<b>Factory setting</b>	5

---

### "Serial interface" submenu

---

<b>Navigation</b>	 Expert → Communication → Serial interface
<b>Description</b>	Contains the settings required if you are using the RS232 or RS485 interface of the device.

---

### Type

---

<b>Navigation</b>	 Expert → Communication → Serial interface → Type Direct access code: 150100-000
<b>Description</b>	Configure how the serial interface is used. Pay attention to the terminal assignment.
<b>Options</b>	RS232, RS485, Debug (only for service purposes)
<b>Factory setting</b>	RS232

---

### Protocol

---

<b>Navigation</b>	 Expert → Communication → Serial interface → Protocol Direct access code: 150105-000
<b>Description</b>	Define the serial interface protocol. Note: The device automatically disables incompatible settings.
<b>Options</b>	PC software, Modbus Slave (only if type = RS485)
<b>Factory setting</b>	PC software

---

### Baud rate

---

<b>Navigation</b>	 Expert → Communication → Serial interface → Baud rate Direct access code: 150101-000
-------------------	---

---

<b>Description</b>	Transmission speed ("Baud rate") - must be the same as the settings for the PC software.
<b>Options</b>	9600, 19200, 38400, 57600, 115200
<b>Factory setting</b>	19200

---

### Parity

---

<b>Navigation</b>	 Expert → Communication → Serial interface → Parity Direct access code: 150103-000
<b>Description</b>	Parity Only visible if protocol ≠ PC software
<b>Options</b>	None, Even, Odd
<b>Factory setting</b>	None

---

### Stop bits

---

<b>Navigation</b>	 Expert → Communication → Serial interface → Stop bits Direct access code: 150104-000
<b>Description</b>	Stop bits Only visible if protocol ≠ PC software
<b>Options</b>	1, 2
<b>Factory setting</b>	1

---

### Device address

---



<b>Navigation</b>	 Expert → Communication → Serial interface → Device address Direct access code: 150102-000
<b>Description</b>	Every device operated using RS232/RS485 must have an individual address (00-30). Only visible if type = RS485
<b>User entry</b>	0 to 30
<b>Factory setting</b>	0

---

### "Modbus Slave" submenu (option)

---

---

<b>Navigation</b>	 Expert → Communication → Modbus Slave
<b>Description</b>	Configure the Modbus settings for the device.  Detailed descriptions of this device option can be found in the associated documentation.

---

### Modbus

---

<b>Navigation</b>	 Expert → Communication → Modbus Slave → Modbus Direct access code: 480000-000
<b>Description</b>	Specify the physical interface to be used.
<b>Options</b>	Not used, RS485, Ethernet
<b>Factory setting</b>	Not used

---

### Device address

---

<b>Navigation</b>	 Expert → Communication → Modbus Slave → Device address Direct access code: 480001-000
<b>Description</b>	Enter the device address at which this device can be accessed on the bus. Only visible if Modbus = RS485
<b>User entry</b>	1 to 247
<b>Factory setting</b>	1

---

### Port

---

<b>Navigation</b>	 Expert → Communication → Modbus Slave → Port Direct access code: 480004-000
<b>Description</b>	Port via which the Modbus protocol can be activated. Only visible if Modbus = Ethernet
<b>User entry</b>	Number (max. 5 digits)
<b>Factory setting</b>	502

---

### "Serial interface" submenu

---

<b>Navigation</b>	 Expert → Communication → Modbus Slave → Serial interface
-------------------	--

---

**Description** Contains settings for the serial interface.  
Only visible if Modbus = RS485

---

### Baud rate

---

**Navigation**  Expert → Communication → Modbus Slave → Serial interface → Baud rate  
Direct access code: 150101-000

**Description** Transmission speed ("Baud rate") - must be the same as the settings for the PC software.  
Only visible if Modbus = RS485

**Options** 9600, 19200, 38400, 57600, 115200

**Factory setting** 19200

---

### Parity

---

**Navigation**  Expert → Communication → Modbus Slave → Serial interface → Parity  
Direct access code: 150103-000

**Description** Parity  
Only visible if Modbus = RS485

**Options** None, Even, Odd

**Factory setting** None

---

### Stop bits

---

**Navigation**  Expert → Communication → Modbus Slave → Serial interface → Stop bits  
Direct access code: 150104-000

**Description** Parity  
Only visible if Modbus = RS485 and parity = None

**Options** 1, 2

**Factory setting** 1



### 16.1.5 "Application" submenu

Define various application-specific settings (e.g., group settings, limit values etc.).

---

#### "Maths - Maths x" submenu

---

<b>Navigation</b>	 Expert → Application → Maths → Maths x
<b>Description</b>	Configuration of the mathematics channels.  x = place holder for selected mathematics channel

---

#### Function

---

<b>Navigation</b>	 Expert → Application → Maths → Maths x → Function Direct access code: 400000-000 Examples: Maths 1: 400000-000; Maths 4: 400000-003
<b>Description</b>	Switch mathematics channel on or off.
<b>Options</b>	Switched off, Formula editor
<b>Factory setting</b>	Switched off

---

#### Channel ident.

---

<b>Navigation</b>	 Expert → Application → Maths → Maths x → Channel ident. Direct access code: 400001-000 Examples: Maths 1: 400001-000; Maths 4: 400001-003
<b>Description</b>	Measuring point name (e.g., "Pump") or description of the function performed with this input (e.g., "Fault message").
<b>User entry</b>	Text (max. 16 characters)
<b>Factory setting</b>	Maths x

---

#### Formula

---

<b>Navigation</b>	 Expert → Application → Maths → Maths x → Formula Direct access code: 400002-000 Examples: Maths 1: 400002-000; Maths 4: 400002-003
-------------------	--

**Description** Enter the desired calculation formula.  
Analog, digital or already active mathematics channels can be used.  
Description of formula editor →  148  
Only visible if function = Formula editor

**User entry** Formula

---

### The result is

---

**Navigation**  Expert → Application → Maths → Maths x → The result is  
Direct access code: 400003-000  
Examples: Maths 1: 400003-000; Maths 4: 400003-003

**Description** Configure which data type the calculation returns. This setting affects how the channel saves and is displayed.  
If you add 2 analog channels, for example, the result is an "instantaneous value".  
Instantaneous value: If, for example, two analog channels are added ( $AI(1;1)+AI(1;2)$ ), the result is an instantaneous value.  
State: The state/status of an individual analog input can be output as the result. A relay can also be actuated as a result.  
Counter: If, for example, two counters from digital inputs are added ( $DI(3;1)+DI(3;5)$ ), the result is a counter.  
Operating time from status: The status (logical "1" or "0") of one or more digital inputs that are connected by addition can be analyzed. If the result of the calculation is not equal to 0, the counter for the operating time starts. The time is increased by 0.1 s every 100 ms.  
Operating time from total: If several digital inputs that are configured as "operational time" are added together, the result is the total of all the individual operating times.  
Control input: The function corresponds to a digital input that has been configured as a control input.

**Options** Instantaneous value, State, Counter, Operating time from status, Operating time from total, Control input

**Factory setting** Instantaneous value

---

### Plot type

---

**Navigation**  Expert → Application → Maths → Maths x → Plot type  
Direct access code: 400015-000  
Examples: Maths 1: 400015-000; Maths 4: 400015-003

**Description** The mathematics channels are recalculated every 100 ms.  
Depending on the save cycle, the selected data is determined/saved from the calculated values.

**Options** Instantaneous value, Average, Minimum value, Maximum value, Minimum + Maximum, Counter, Current value + Counter

**Factory setting** Average

Engineering unit	
<b>Navigation</b>	 Expert → Application → Maths → Maths x → Engineering unit Direct access code: 400004-000 Examples: Maths 1: 400004-000; Maths 4: 400004-003
<b>Description</b>	Unit of the calculated value. Only visible if the result is = Instantaneous value or Counter
<b>User entry</b>	Text (max. 6 characters)

Decimal point	
<b>Navigation</b>	 Expert → Application → Maths → Maths x → Decimal point Direct access code: 400005-000 Examples: Maths 1: 400005-000; Maths 4: 400005-003
<b>Description</b>	Number of places after decimal point for the display. Only visible if function = Formula editor and the result is = Instantaneous value or Counter
<b>Options</b>	None, One (X.Y), Two (X.YY), Three (X.YYY), Four (X.YYYY), Five (X.YYYYY)
<b>Factory setting</b>	One (X.Y)

Action	
<b>Navigation</b>	 Expert → Application → Maths → Maths x → Action Direct access code: 400006-000 Examples: Maths 1: 400006-000; Maths 4: 400006-003
<b>Description</b>	Set up the function of the control input. Only visible if the result is = Control input

Action	Description
Start/stop recording	The device only saves data as long as a high signal is present
Screensaver on	Switches backlighting/display off, low = off, high = on
Lock setup	The user can only change the setup if a low signal is present
Time synchronization	If a high signal is applied, the device rounds the system time up/down (only for Low → High change): 0 to 29 → round down; 30 to 59 → round up
Set point monitoring on/off	The entire set point monitoring function of the device can be switched on (for "High") or switched off (for "Low").
Block keyboard/navigator	The device can only be operated if a low signal is present. Otherwise, all key activation and navigator actions are discarded.
Start/stop analysis 1	Starts/ends the external analysis (the analysis only runs as long as the signal is high). Measured value acquisition for the graphic display continues.

**Options** Switched off, Start/stop recording, Screensaver on, Lock setup, Time synchronization, Set point monitoring on/off, Block keyboard/navigator, Start/stop analysis 1

**Factory setting** Switched off

---

### Switches relay

---

**Navigation**  Expert → Application → Maths → Maths x → Switches relay  
Direct access code: 400007-000  
Examples: Maths 1: 400007-000; Maths 4: 400007-003

**Description** Switches the relevant relay when the digital input is low/high.  
Only visible if the result is = Control input or State

**Options** Not used, Relay x  
All the available relays are displayed.

**Factory setting** Not used

---

### Description 'H'

---

**Navigation**  Expert → Application → Maths → Maths x → Description 'H'  
Direct access code: 400008-00x  
Examples: Maths 1: 400008-000; Maths 4: 400008-003

**Description** Condition description when the digital input is active. This text is shown on the display and saved to memory.  
Only visible if the result is = Control input or State

**User entry** Text (max. 6 characters)

**Factory setting** On

---

### Description 'L'

---

**Navigation**  Expert → Application → Maths → Maths x → Description 'L'  
Direct access code: 400009-00x  
Examples: Maths 1: 400009-000; Maths 4: 400009-003

**Description** Condition description when the digital input is not active. This text is shown on the display and saved to memory.  
Only visible if the result is = Control input or State



**User entry** Text (max. 6 characters)

**Factory setting** Off

---

<b>Save event</b>	
-------------------	--

---

<b>Navigation</b>	 Expert → Application → Maths → Maths x → Save event Direct access code: 400010-00x Examples: Maths 1: 400010-000; Maths 4: 400010-003
<b>Description</b>	Determines whether the condition change from low to high or high to low is stored in the event logbook.  Requires higher memory capacity. Only visible if the result is = Control input or State
<b>Options</b>	No, Yes, only "On" message
<b>Factory setting</b>	Yes

---

<b>Event message</b>	
----------------------	--

---

<b>Navigation</b>	 Expert → Application → Maths → Maths x → Event message Direct access code: 400018-00x Examples: Maths 1: 400018-000; Maths 4: 400018-003
<b>Description</b>	"Do not acknowledge": No message is shown if the state of the mathematics channel changes. "Acknowledge": A message window is shown on the screen which has to be acknowledged by operating a push button. Only visible if the result is = Control input or State
<b>Options</b>	Do not acknowledge, Acknowledge
<b>Factory setting</b>	Do not acknowledge

---

<b>Event text L-&gt;H</b>	
---------------------------	--

---

<b>Navigation</b>	 Expert → Application → Maths → Maths x → Event text L->H Direct access code: 400011-00x Examples: Maths 1: 400011-000; Maths 4: 400011-003
<b>Description</b>	Description of condition change from low to high. Event text is stored (e.g., start filling). Only visible if the result is = Control input or State
<b>User entry</b>	Text (max. 22 characters)

---

**Event text H->L**



---

<b>Navigation</b>	 Expert → Application → Maths → Maths x → Event text H->L Direct access code: 400012-00x Examples: Maths 1: 400012-000; Maths 4: 400012-003
<b>Description</b>	Description of condition change from high to low. Event text is stored (e.g., stop filling). Only visible if the result is = Control input or State
<b>User entry</b>	Text (max. 22 characters)

---

**Record duration**



---

<b>Navigation</b>	 Expert → Application → Maths → Maths x → Record duration Direct access code: 400013-00x Examples: Maths 1: 400013-000; Maths 4: 400013-003
<b>Description</b>	The duration between "On" and "Off" can be recorded. The duration is appended to the "Off" event text (<hhhh>h<mm>:<ss>). Power failure times do not affect the duration. If the digital channel was "on" before the power failure and is still "on" after the power failure, the duration continues. Only visible if the result is = Control input or State
<b>Options</b>	No, Yes
<b>Factory setting</b>	No

---

**Zoom start**



---

<b>Navigation</b>	 Expert → Application → Maths → Maths x → Zoom start Direct access code: 400016-00x Examples: Maths 1: 400016-000; Maths 4: 400016-003
<b>Description</b>	If the whole value range is not used, you can configure the lower value of the required range here. The zoom has no effect on saving. Only visible if the result is = Instantaneous value
<b>User entry</b>	Number (max. 8 digits)
<b>Factory setting</b>	0

---

**Zoom end**



---

<b>Navigation</b>	 Expert → Application → Maths → Maths x → Zoom end Direct access code: 400017-00x Examples: Maths 1: 400017-000; Maths 4: 400017-003
<b>Description</b>	Like "Zoom start". Enter the upper value of the required range. Only visible if the result is = Instantaneous value
<b>User entry</b>	Number (max. 8 digits)
<b>Factory setting</b>	100

---

### Totalizer

---

<b>Navigation</b>	 Expert → Application → Maths → Maths x → Totalizer Direct access code: 400014-00x Examples: Maths 1: 400014-000; Maths 4: 400014-003
<b>Description</b>	Initial setting for the totalizer. Useful when continuing measurements recorded to date with an (electro)-mechanical counter. Only visible if the result is = Counter, Operating time from status or Operating time from total
<b>User entry</b>	Number (max. 15 digits)
<b>Factory setting</b>	0

#### Formula editor



Enter the desired calculation formula.

Analog, digital or already active mathematics channels can be used.

---

### Formula editor

---

<b>Navigation</b>	 Expert → Application → Maths → Maths x → Formula Direct access code: 400002-000
	 x = place holder for selected mathematics channel
	 A text field with the formula currently used appears. If the field is empty a formula has not yet been defined for the mathematics channel.
<b>Description</b>	Individual channels can be mathematically linked and calculated with functions. The mathematics channels calculated in this way are treated as "real" channels, regardless of whether they are connected conventionally or via fieldbus. Enter the desired calculation formula. Analog and digital channels can be used, as can mathematics channels that are already active. A formula with up to 200 characters can be created using this editor. If the formula is finished, click OK to close the editor and accept the formula entered. The common entry and arithmetic operators and inputs are described in detail in the following sections.

*Inputs*

Inputs are described in the formula using the following syntax:

**Input type (signal type; channel number)**

Type of input	Description
AI	Analog inputs
DI	Digital inputs
MI	Mathematics inputs

Signal type	Description
1	Instantaneous value (measured value)
2	State
3	Counter/operating time
5	Validity: The validity of an analog channel or a mathematics channel is relayed. The relayed value of the function is 0 in the event of: <ul style="list-style-type: none"> <li>▪ Cable open circuit</li> <li>▪ Invalid measured value</li> <li>▪ Sensor error</li> <li>▪ Input signal too high/low</li> <li>▪ Error value</li> </ul> The relayed value of the function is 1 in the event of: Measured value OK, even if the limit value is breached
6	Delta count
7 to 10	Analysis 1 to 4
11	Totalizer
12	Duration

 Not all signal types are available for each input type. These depend on the respective device options.

**Channel number:**

Analog channel 1 = 1, analog channel 2 = 2, digital channel 1 = 1, ...

*Examples:*

DI(2;4)	State of digital channel 4
AI(1;1)	Instantaneous value of analog channel 1

**Status of a limit value:**

LMT (type, limit number)

Type	Description
1	"Instantaneous value": Currently set limit value
2	"State": The function returns the status of a limit value The result is 1 if the limit value is violated. The result is 0 if <ul style="list-style-type: none"> <li>▪ The limit value is not violated</li> <li>▪ The limit value is not switched on</li> <li>▪ Limit value monitoring is switched off (e.g., per control input)</li> </ul>

*Examples:*

LMT (1;1)	Instantaneous value of limit value 1
LMT (2;3)	State of limit value 3

*Priority of operators/functions*

The formula is processed based on universally applicable mathematics rules:

- Parentheses first
- Exponents before multiplication or division
- Multiplication or division before addition or subtraction
- Calculate from left to right

*Operators*

*Arithmetic operators:*

Operator	Function
+	Addition
-	Subtraction negative sign
*	Multiplication
/	Division

*Decimal separator*

Both the decimal point and the decimal comma can be used in the formula editor. Thousand separators are not supported.

*Check whether formula is valid or malfunctions*

A formula is invalid if:

- The channels used are not switched on or are in the wrong operating mode (is not verified during formula entry as the channel could be switched on subsequently)
- It contains invalid characters/formulas/functions/operators
- Syntax errors (e.g., wrong number of parameters) occur in the formulas
- There are incorrect parentheses in the formula (number of open parentheses unequal to number of closed parentheses)
- Division is by zero
- A channel refers to itself (infinite recursion)

Invalid formulas are deactivated when the setup is accepted or the device is started.

Undetectable errors: wherever possible, errors in the formula are reported immediately during input. However, given the possible complexity of the formula entered (e.g., nested formulas), it is not possible to detect every error.

---

## "Totalization" submenu

---

### Navigation

 Expert → Application → Maths → Maths x → Totalization

### Description

Settings only needed if the calculated value (e.g., for quantity calculation) should be integrated. Analysis time frames, see "Signal analysis".

---

## Totalization

---

<b>Navigation</b>	 Expert → Application → Maths → Maths x → Totalization → Totalization Direct access code: 400050-00x Examples: Maths 1: 400050-000; Maths 4: 400050-003
<b>Description</b>	Totalization allows the volume (in m <sup>3</sup> ) to be calculated from an analog signal (e.g., flow rate in m <sup>3</sup> /h).
<b>Options</b>	No, Yes
<b>Factory setting</b>	No

---

### Totalization base

---

<b>Navigation</b>	 Expert → Application → Maths → Maths x → Totalization → Totalization base Direct access code: 400051-00x Examples: Maths 1: 400051-000; Maths 4: 400051-003
<b>Description</b>	Select the required time base. Example: ml/s → time base seconds (s); m <sup>3</sup> /h → time base hours (h). Only visible if totalization = Yes
<b>Options</b>	Second (s), Minute (min), Hour (h), Day (d)
<b>Factory setting</b>	Second (s)

---

### Unit

---

<b>Navigation</b>	 Expert → Application → Maths → Maths x → Totalization → Unit Direct access code: 400052-00x Examples: Maths 1: 400052-000; Maths 4: 400052-003
<b>Description</b>	Enter the unit for the quantity calculated by totalization (e.g., "m <sup>3</sup> "). Only visible if totalization = Yes
<b>User entry</b>	Text (max. 6 characters)

---

### Low flow cut off

---

<b>Navigation</b>	 Expert → Application → Maths → Maths x → Totalization → Low flow cut off Direct access code: 400053-00x Examples: Maths 1: 400053-000; Maths 4: 400053-003
-------------------	--

**Description** If the volume flow recorded is below the set value, these quantities are not added to the counter.  
If the input is scaled from 0 to y, or if the pulse input is used, all values that are smaller than the set value are not recorded.  
If the input is scaled from -x to +y, all values around the zero point (i.e., also negative values) are not recorded.  
Only visible if totalization = Yes

**User entry** Number (max. 8 digits)

**Factory setting** 0

---

### Calc. factor

---

**Navigation**  Expert → Application → Maths → Maths x → Totalization → Calc. factor  
Direct access code: 400054-00x  
Examples: Maths 1: 400054-000; Maths 4: 400054-003

**Description** Factor for calculating the integrated value (e.g., the transmitter delivers l/s → totalization base = second → engineering unit required is m<sup>3</sup> → enter factor 0.001)  
Only visible if totalization = Yes

**User entry** Number (max. 8 digits)

**Factory setting** 1.0

---

### Totalizer

---

**Navigation**  Expert → Application → Maths → Maths x → Totalization → Totalizer  
Direct access code: 400055-00x  
Examples: Maths 1: 400055-000; Maths 4: 400055-003

**Description** Initial setting for the totalizer. Useful when continuing measurements recorded to date with an (electro)-mechanical counter.  
Only visible if totalization = Yes

**User entry** Number (max. 15 digits)

**Factory setting** 0

---

### "Fault mode" submenu

---

**Navigation**  Expert → Application → Maths → Maths x → Fault mode

**Description** Contains settings that define how this channel is to react under fault conditions (e.g., if an input channel has a cable open circuit or there is division by 0).

---

**On error**



---

<b>Navigation</b>	 Expert → Application → Maths → Maths x → Fault mode → On error Direct access code: 400060-00x Examples: Maths 1: 400060-000; Maths 4: 400060-003
<b>Description</b>	Configure which value the device should continue working with (for calculations) if the measured value is not valid (e.g., cable open circuit).
<b>Options</b>	Invalid calculation, Error value
<b>Factory setting</b>	Invalid calculation

---

**Error value**



---

<b>Navigation</b>	 Expert → Application → Maths → Maths x → Fault mode → Error value Direct access code: 400061-00x Examples: Maths 1: 400061-000; Maths 4: 400061-003
<b>Description</b>	The device continues calculating with this value in the event of an error. Only visible if on error = Error value
<b>User entry</b>	Number (max. 8 digits)
<b>Factory setting</b>	0

---

**Copy settings**



---

<b>Navigation</b>	 Expert → Application → Maths → Maths x → Copy settings Direct access code: 400200-00x Examples: Maths 1: 400200-000; Maths 4: 400200-003
<b>Description</b>	Copies settings from actual channel to selected channel.
<b>Options</b>	No, In maths. channel x Users can choose from all the available maths channels.
<b>Factory setting</b>	No

---

**"Signal analysis" submenu**



---

<b>Navigation</b>	 Expert → Application → Signal analysis
<b>Description</b>	Contains settings for signal analysis (saving).

---

**Analysis x**



---

<b>Navigation</b>	 Expert → Application → Signal analysis → Analysis x Direct access code: 44000x-000 Examples: Analysis 1: 440000-000; Analysis 4: 440003-000
<b>Description</b>	For the set timeframe, determines the minimum, maximum and average values, quantities and operating times.  If the "Controlled externally" option is to be used, a digital input or a maths channel must be set to "Function = Control input" and "Action = Start/stop analysis x". Only analysis 1 can be configured; analyses 2-4 are permanently set to daily analysis, monthly analysis and annual analysis
<b>Options</b>	Switched off, Controlled externally, 1min, 2min, 3min, 4min, 5min, 10min, 15min, 30min, 1h, 2h, 3h, 4h, 6h, 8h, 12h
<b>Factory setting</b>	Switched off

---

**Synchron. time**



---

<b>Navigation</b>	 Expert → Application → Signal analysis → Synchron. time Direct access code: 440004-000
<b>Description</b>	Time for completing the signal analysis. If, for example, 07:00 is entered, then the daily analysis will run from 07:00 on one day until 07:00 on the following day.
<b>User entry</b>	Time
<b>Factory setting</b>	00:00

---

**Reset to zero**



---

<b>Navigation</b>	 Expert → Application → Signal analysis → Reset to zero Direct access code: 440007-000
<b>Description</b>	Reset analysis. Note: Should only be executed after the device has adopted the setup.
<b>Options</b>	Please select, Analysis x, Totalizer, All
<b>Factory setting</b>	Please select

---

**Reset channel**



---

<b>Navigation</b>	 Expert → Application → Signal analysis → Reset channel Direct access code: 440010-000
<b>Description</b>	Reset analysis of a single channel. Note: Should only be executed after the device has adopted the setup.
<b>Options</b>	Please select, Universal input x, Digital input x, Maths x, Set point x, Relay x All active inputs are available for selection.
<b>Factory setting</b>	Please select

---

### "Limits" submenu

---

<b>Navigation</b>	 Expert → Application → Limits
<b>Description</b>	Limit values can monitor the measured values. In the event of an alarm violation relays can be switched, for example.

---

### Add limit value

---

<b>Navigation</b>	 Expert → Application → Limits → Add limit value Direct access code: 450300-000
<b>Description</b>	Add a new limit value.
<b>Options</b>	No, Yes
<b>Factory setting</b>	No

---

### Delete limit value

---

<b>Navigation</b>	 Expert → Application → Limits → Delete limit value Direct access code: 450301-000
<b>Description</b>	Delete a limit value from the list.
<b>Options</b>	No, limit value x
<b>Factory setting</b>	No

---

### "Limit x" submenu

---

<b>Navigation</b>	 Expert → Application → Limits → Limit x
-------------------	---

**Description** View or change the settings for the selected limit value.

 x = place holder for selected limit value

---

**Channel/value**

---

**Navigation**  Expert → Application → Limits → Limit x → Channel/value  
 Direct access code: 450000-0xx  
 Examples: Limit 1: 450000-000; Limit 30: 450000-029

**Description** Select which input/calculated value the limit value refers to.

**Options** Switched off, Universal input x, Digital input x, Maths x

**Factory setting** Switched off

---

**Type**

---

**Navigation**  Expert → Application → Limits → Limit x → Type  
 Direct access code: 450001-0xx  
 Examples: Limit 1: 450001-000; Limit 30: 450001-029

**Description** Type of limit value (depends on the input variable).

**Options** Switched off, Upper set point, Lower set point, Analysis x

*Description of the individual set point types*

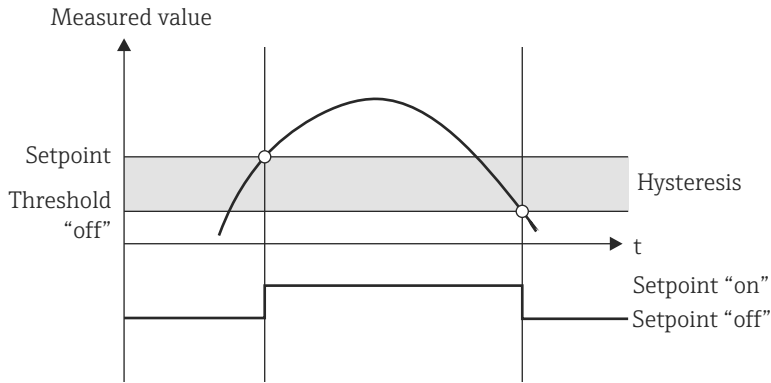
Set point type/function	Description
Hysteresis	For every set point, the switch point can be controlled via a hysteresis. The hysteresis is set as an absolute value (only positive values) in the unit of the respective channel (e.g., upper set point = 100 m, hysteresis = 1 m: set point on = 100 m, set point off = 99 m)
Upper set point	The limit value is active if the value exceeds the configured value. The limit value is switched off if the limit value, including hysteresis, is undershot.  

A0010187-EN

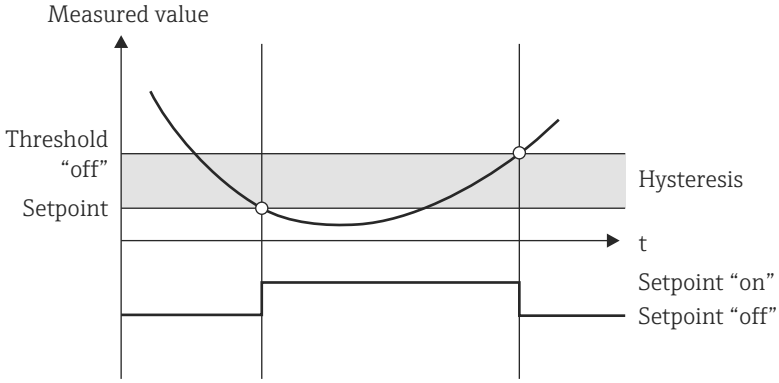
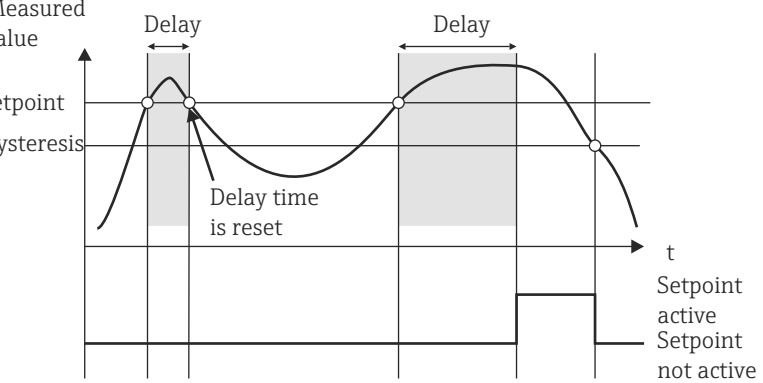
Set point type/function	Description
<p>Lower set point</p>	<p>The limit is active if the value drops below the configured value. The limit value is switched off if the limit value, including hysteresis, is exceeded.</p>  <p style="text-align: right;">A0010186-EN</p>
<p>Special case: Hysteresis and delay for one limit value</p>	<p>In the special case where the hysteresis and limit value delay are activated, a limit value is switched according to the following principle. If the hysteresis and the limit value delay are activated, the delay becomes active when a limit value is exceeded and measures the time since the start of limit value overshoot. If the measured value falls below the limit value, the delay is reset. This also occurs if the measured value falls below the limit value, but continues to be higher than the set hysteresis value. When the limit value is exceeded again, the time delay becomes active again and starts measuring from 0.</p>  <p style="text-align: right;">A0010193-EN</p>

**Factory setting** Switched off

**Identifier**

**Navigation**  Expert → Application → Limits → Limit x → Identifier  
 Direct access code: 450015-0xx  
 Examples: Limit 1: 450015-000; Limit 30: 450015-029

**Description** Name of the limit for identification purposes.

**User entry** Text (max. 16 characters)

**Factory setting** Limit x

---

**Set point**

---

**Navigation**  Expert → Application → Limits → Limit x → Set point  
 Direct access code: 450003-0xx  
 Examples: Limit 1: 450003-000; Limit 30: 450003-029

**Description** Limit value in the set process unit, e.g., in °C, m<sup>3</sup>/h

**User entry** Number (max. 10 digits)

**Factory setting** 0

---

**Hysteresis (abs.)**

---

**Navigation**  Expert → Application → Limits → Limit x → Hysteresis (abs.)  
 Direct access code: 450004-0xx  
 Examples: Limit 1: 450004-000; Limit 30: 450004-029

**Description** The alarm condition is only canceled when the signal has changed into the normal operation range by the preset value.

**User entry** Number (max. 8 digits)

**Factory setting** 0

---

**Time delay**

---

**Navigation**  Expert → Application → Limits → Limit x → Time delay  
 Direct access code: 450005-0xx  
 Examples: Limit 1: 450005-000; Limit 30: 450005-029

**Description** In order to be interpreted as a limit value, the signal must exceed or undercut the preset value by at least the configured time.

**User entry** 0 to 99999 s

**Factory setting** 0 s

---

**Switches**

---

**Navigation**  Expert → Application → Limits → Limit x → Switches  
 Direct access code: 450006-0xx  
 Examples: Limit 1: 450006-000; Limit 30: 450006-029

<b>Description</b>	Switches the appropriate output in the limit value state.
<b>Options</b>	Not used, Relay x
<b>Factory setting</b>	Not used

---

### LV messages

---

<b>Navigation</b>	 Expert → Application → Limits → Limit x → LV messages Direct access code: 450007-0xx Examples: Limit 1: 450007-000; Limit 30: 450007-029
<b>Description</b>	"Do not acknowledge": Alarm condition is signaled by highlighting the tag name in red (no message is output). "Acknowledge": In the event of an alarm, a message is also displayed. This message then has to be acknowledged.
<b>Options</b>	Do not acknowledge, Acknowledge
<b>Factory setting</b>	Do not acknowledge

---

### Save event

---

<b>Navigation</b>	 Expert → Application → Limits → Limit x → Save event Direct access code: 450008-0xx Examples: Limit 1: 450008-000; Limit 30: 450008-029
<b>Description</b>	Stores a message in the event logbook on limit value violation.
<b>Options</b>	No, Yes, only "On" message
<b>Factory setting</b>	Yes

---

### Event text LV on

---

<b>Navigation</b>	 Expert → Application → Limits → Limit x → Event text LV on Direct access code: 450009-0xx Examples: Limit 1: 450009-000; Limit 30: 450009-029
<b>Description</b>	This text (including date and time) is shown on the display and stored in the event logbook. Only available if "LV messages" is set to "Acknowledge" or "Save event" is set to "Yes". If no text is entered, the device generates its own text (e.g., Analog 1 > 100%).
<b>User entry</b>	Text (max. 22 characters)

---

**Event text LV off**



---

<b>Navigation</b>	 Expert → Application → Limits → Limit x → Event text LV off Direct access code: 450010-0xx Examples: Limit 1: 450010-000; Limit 30: 450010-029
<b>Description</b>	The same as "Event text LV on", but on return from alarm to normal condition.
<b>User entry</b>	Text (max. 22 characters)

---

**Record duration of LV on**



---

<b>Navigation</b>	 Expert → Application → Limits → Limit x → Record duration of LV on Direct access code: 450011-0xx Examples: Limit 1: 450011-000; Limit 30: 450011-029
<b>Description</b>	The duration of a limit value violation can be recorded. The duration is appended to the "Event text LV off" (format: <hhhh>h<mm>:<ss>). Power failure times do not affect the duration. If the set point was violated before the power failure and is still violated after the power failure, the duration continues.
<b>Options</b>	No, Yes
<b>Factory setting</b>	No

---

**Save cycle**



---

<b>Navigation</b>	 Expert → Application → Limits → Limit x → Save cycle Direct access code: 450012-0xx Examples: Limit 1: 450012-000; Limit 30: 450012-029
<b>Description</b>	Normal: Save in normal store cycle. Alarm cycle: Fast storage during an alarm violation, e.g., every second. Caution: Requires higher memory capacity!  <ul style="list-style-type: none"> <li>▪ The save cycle is set under signal groups .</li> <li>▪ In the event of an alarm violation, all the groups are saved in the alarm cycle.</li> </ul>
<b>Options</b>	Normal, Alarm cycle
<b>Factory setting</b>	Normal

---

**Draw help line**



---

<b>Navigation</b>	 Expert → Application → Limits → Limit x → Draw help line Direct access code: 450013-0xx Examples: Limit 1: 450013-000; Limit 30: 450013-029
<b>Description</b>	The user can configure whether this set point should be displayed in the graphic as a help line (in the color of the channel). Note: 4 lines can be shown per channel in a single group.
<b>Options</b>	No, Yes
<b>Factory setting</b>	No

---

### Copy settings



---

<b>Navigation</b>	 Expert → Application → Limits → Limit x → Copy settings Direct access code: 450200-0xx Examples: Limit 1: 450200-000; Limit 30: 450200-029
<b>Description</b>	Copies settings from actual channel to selected channel.
<b>Options</b>	No, in limit x (all the limit values are displayed)
<b>Factory setting</b>	No

---

### "Signal groups" submenu



---

<b>Navigation</b>	 Expert → Application → Signal groups
<b>Description</b>	Group the analog, digital and/or mathematics channels such that you can call up important information during operation (e.g., temperatures, signals in plant unit 1)  Maximum 8 channels per group!

---

### "Group x" submenu

---

<b>Navigation</b>	 Expert → Application → Signal groups → Group x
<b>Description</b>	 x = place holder for selected group General settings for displaying the measured value and saving data.

---

### Identifier

---

<b>Navigation</b>	 Expert → Application → Signal groups → Group x → Identifier Direct access code: 460000-0xx Examples: Group 1: 460000-000; Group 4: 460000-003
-------------------	---

**Description** Enter a name for these groups

**User entry** Text (max. 20 characters)

**Factory setting** Group x

---

### Save cycle

---

**Navigation**  Expert → Application → Signal groups → Group x → Save cycle  
Direct access code: 460001-0xx  
Examples: Group 1: 460001-000; Group 4: 460001-003

**Description** Configure the save cycle with which this group should be saved in normal conditions (see also set point / save cycle).

 The save cycle is independent of the measured value display (see Operating Instructions).

**Options** Off, 1s, 2s, 3s, 4s, 5s, 10s, 15s, 20s, 30s, 1min, 2min, 3min, 4min, 5min, 10min, 15min, 30min, 1h

**Factory setting** 1min

---

### Alarm cycle

---

**Navigation**  Expert → Application → Signal groups → Group x → Alarm cycle  
Direct access code: 460002-0xx  
Examples: Group 1: 460002-000; Group 4: 460002-003

**Description** Configure the save cycle with which this group should be saved in an alarm condition (limit value violation).  
Caution: Requires higher memory capacity

**Options** Off, 1s, 2s, 3s, 4s, 5s, 10s, 15s, 20s, 30s, 1min, 2min, 3min, 4min, 5min, 10min, 15min, 30min, 1h

**Factory setting** 1min

---

### Display blue

---

**Navigation**  Expert → Application → Signal groups → Group x → Display blue  
Direct access code: 460003-00x  
Examples: Group 1: 460003-000; Group 4: 460003-003

**Description** Choose which input/calculated variable is to be displayed in this group.

**Options** Switched off, Universal input x, Digital input x, Maths x

**Factory setting** Switched off

---

### Display

---

**Navigation**  Expert → Application → Signal groups → Group x → Display  
Direct access code: 460004-00x  
Examples: Group 1: 460004-000; Group 4: 460004-003

**Description** Select which data from the selected channel should be displayed.  
 If the "Everything" option is selected, the device switches cyclically between the various values of the channel (instantaneous value, analysis 1 etc.)

**Options** Instantaneous value/state, Analysis x, Totalizer, Everything

**Factory setting** Instantaneous value/state

---

### Display black

---

**Navigation**  Expert → Application → Signal groups → Group x → Display black  
Direct access code: 460005-00x  
Examples: Group 1: 460005-000; Group 4: 460005-003

**Description** Choose which input/calculated variable is to be displayed in this group.

**Options** Switched off, Universal input x, Digital input x, Maths x

**Factory setting** Switched off

---

### Display

---

**Navigation**  Expert → Application → Signal groups → Group x → Display  
Direct access code: 460006-0xx  
Examples: Group 1: 460006-000; Group 4: 460006-003

**Description** Select which data from the selected channel should be displayed.

**Options** Instantaneous value/state, Analysis x, Totalizer, Everything

**Factory setting** Instantaneous value/state

---

### Display red

---

<b>Navigation</b>	 Expert → Application → Signal groups → Group x → Display red Direct access code: 460007-00x Examples: Group 1: 460007-000; Group 4: 460007-003
<b>Description</b>	Choose which input/calculated variable is to be displayed in this group.
<b>Options</b>	Switched off, Universal input x, Digital input x, Maths x
<b>Factory setting</b>	Switched off

---

### Display

---

<b>Navigation</b>	 Expert → Application → Signal groups → Group x → Display Direct access code: 460008-0xx Examples: Group 1: 460008-000; Group 4: 460008-003
<b>Description</b>	Select which data from the selected channel should be displayed.
<b>Options</b>	Instantaneous value/state, Analysis x, Totalizer, Everything
<b>Factory setting</b>	Instantaneous value/state

---

### Display green

---

<b>Navigation</b>	 Expert → Application → Signal groups → Group x → Display green Direct access code: 460009-00x Examples: Group 1: 460009-000; Group 4: 460009-003
<b>Description</b>	Choose which input/calculated variable is to be displayed in this group.
<b>Options</b>	Switched off, Universal input x, Digital input x, Maths x
<b>Factory setting</b>	Switched off

---

### Display

---

<b>Navigation</b>	 Expert → Application → Signal groups → Group x → Display Direct access code: 460010-0xx Examples: Group 1: 460010-000; Group 4: 460010-003
<b>Description</b>	Select which data from the selected channel should be displayed.
<b>Options</b>	Instantaneous value/state, Analysis x, Totalizer, Everything
<b>Factory setting</b>	Instantaneous value/state

---

**Display violet**



---

<b>Navigation</b>	 Expert → Application → Signal groups → Group x → Display violet Direct access code: 460011-00x Examples: Group 1: 460011-000; Group 4: 460011-003
<b>Description</b>	Choose which input/calculated variable is to be displayed in this group.
<b>Options</b>	Switched off, Universal input x, Digital input x, Maths x
<b>Factory setting</b>	Switched off

---

**Display**



---

<b>Navigation</b>	 Expert → Application → Signal groups → Group x → Display Direct access code: 460012-0xx Examples: Group 1: 460012-000; Group 4: 460012-003
<b>Description</b>	Select which data from the selected channel should be displayed.
<b>Options</b>	Instantaneous value/state, Analysis x, Totalizer, Everything
<b>Factory setting</b>	Instantaneous value/state

---

**Display orange**



---

<b>Navigation</b>	 Expert → Application → Signal groups → Group x → Display orange Direct access code: 460013-00x Examples: Group 1: 460013-000; Group 4: 460013-003
<b>Description</b>	Choose which input/calculated variable is to be displayed in this group.
<b>Options</b>	Switched off, Universal input x, Digital input x, Maths x
<b>Factory setting</b>	Switched off

---

**Display**

---

<b>Navigation</b>	 Expert → Application → Signal groups → Group x → Display Direct access code: 460014-0xx Examples: Group 1: 460014-000; Group 4: 460014-003
<b>Description</b>	Select which data from the selected channel should be displayed.

**Options** Instantaneous value/state, Analysis x, Totalizer, Everything

**Factory setting** Instantaneous value/state

---

### Display cyan

---

**Navigation**  Expert → Application → Signal groups → Group x → Display cyan  
Direct access code: 460015-00x  
Examples: Group 1: 460015-000; Group 4: 460015-003

**Description** Choose which input/calculated variable is to be displayed in this group.

**Options** Switched off, Universal input x, Digital input x, Maths x

**Factory setting** Switched off

---

### Display

---

**Navigation**  Expert → Application → Signal groups → Group x → Display  
Direct access code: 460016-0xx  
Examples: Group 1: 460016-000; Group 4: 460016-003

**Description** Select which data from the selected channel should be displayed.

**Options** Instantaneous value/state, Analysis x, Totalizer, Everything

**Factory setting** Instantaneous value/state

---

### Display brown

---

**Navigation**  Expert → Application → Signal groups → Group x → Display brown  
Direct access code: 460017-00x  
Examples: Group 1: 460017-000; Group 4: 460017-003

**Description** Choose which input/calculated variable is to be displayed in this group.

**Options** Switched off, Universal input x, Digital input x, Maths x

**Factory setting** Switched off

---

### Display

---

<b>Navigation</b>	 Expert → Application → Signal groups → Group x → Display Direct access code: 460018-0xx Examples: Group 1: 460018-000; Group 4: 460018-003
<b>Description</b>	Select which data from the selected channel should be displayed.
<b>Options</b>	Instantaneous value/state, Analysis x, Totalizer, Everything
<b>Factory setting</b>	Instantaneous value/state

---

### Grid divisions

---

<b>Navigation</b>	 Expert → Application → Signal groups → Group x → Grid divisions Direct access code: 460019-0xx Examples: Group 1: 460019-000; Group 4: 460019-003
<b>Description</b>	Indicates the number of lines ("amplitude grid") that should be displayed. Example: display of 0 to 100%: select 10 divisions, display 0 to 14pH: select 14 divisions.
<b>Options</b>	1, 2, 3, 4, 5, 6, 7, 8, 9, 10, 11, 12, 13, 14, 15, 16, 17, 18, 19, 20
<b>Factory setting</b>	10

---

### Zoom



---

<b>Navigation</b>	 Expert → Application → Signal groups → Group x → Zoom Direct access code: 460028-0xx Examples: Group 1: 460028-000; Group 4: 460028-003
<b>Description</b>	Defines the zoom that is shown in "Curves" or "Waterfall" display mode. This setting does not affect other display modes (e.g., Curves in range, Bargraph, etc.).
<b>Options</b>	Do not display, Scroll display, Display blue, Display black, Display red, Display green, Display violet, Display orange, Display cyan, Display brown
<b>Factory setting</b>	Do not display

---

### "E-mail" submenu

---

<b>Navigation</b>	 Expert → Application → E-mail  In the case of the "Telealarm" option under Expert → Application → Telealarm → General → Setup e-mail
<b>Description</b>	Contains settings that are required if alarms are to be sent by e-mail.  Test the e-mail settings under Diagnostics → Simulation → E-mail.

---

**SMTP host**



---

<b>Navigation</b>	 Expert → Application → E-mail → SMTP host Direct access code: 510062-000
<b>Description</b>	Enter the SMTP host here. If necessary, contact your network administrator or e-mail provider.
<b>User entry</b>	Text (max. 40 characters)

---

**Server requires SSL**



---

<b>Navigation</b>	 Expert → Application → E-mail → Server requires SSL Direct access code: 510061-000
<b>Description</b>	Specify whether the e-mail server requires a secure connection (SSL). STARTTLS: Runs on the same TCP port as unencrypted SMTP (port 25 or 587). SMTPS: Completely encrypted with own TCP port (465). If necessary, contact your network administrator or e-mail provider.
<b>Options</b>	No, Yes (SMTPS), Yes (STARTTLS)
<b>Factory setting</b>	No

---

**Port**

---

<b>Navigation</b>	 Expert → Application → E-mail → Port Direct access code: 510063-000
<b>Description</b>	Enter the SMTP host here. If necessary, contact your network administrator or e-mail provider.
<b>User entry</b>	Number (max. 4 digits)
<b>Factory setting</b>	25

---

**Sender**

---

<b>Navigation</b>	 Expert → Application → E-mail → Sender Direct access code: 510064-000
-------------------	--

**Description** Enter the e-mail address of the device here (appears as the sender of the e-mail). If necessary, contact your network administrator or e-mail provider.

 If a valid e-mail address is not configured this might cause e-mail transmission problems, depending on the particular provider.

**User entry** Text (max. 60 characters)

---

### User name

---

**Navigation**  Expert → Application → E-mail → User name  
Direct access code: 510066-000

**Description** Specify the user name of the e-mail account. If necessary, contact your network administrator or e-mail provider.

**User entry** Text (max. 60 characters)

---

### Password

---

**Navigation**  Expert → Application → E-mail → Password  
Direct access code: 510067-000

**Description** Enter the password for authentication. If necessary, contact your network administrator or e-mail provider.

**User entry** Text (max. 22 characters)

---

### "E-mail addresses" submenu

---

**Navigation**  Expert → Application → E-mail → E-mail addresses

**Description** Enter all the e-mail addresses to which a message should be sent in the event of an alarm.

 Assignment to the alarms is performed later on.

---

### E-mail address x

---

**Navigation**  Expert → Application → E-mail → E-mail addresses → E-mail address x  
Direct access code:  
E-mail address 1: 510080-000  
to  
E-mail address 5: 510084-000

**Description** Enter an e-mail address to which a message should be sent.

 Assignment to the alarms is performed later on.

**User entry** Text (max. 60 characters)

---

### "Limit value violations" submenu

---

**Navigation**  Expert → Application → E-mail → Limit value violations

**Description** Specify who should receive e-mails when limit value violations occur (both on and off messages).

 Only for limit values where "Save event" is set to "Yes".

---

### Recipient x

---

**Navigation**  Expert → Application → E-mail → Limit value violations → Recipient x  
Direct access code:  
Recipient 1: 510110-000; Recipient 2: 510111-000

**Description** Select who should receive the e-mail.

**Options** Not used, E-mail address x

**Factory setting** Not used

---

### "On/off messages" submenu

---

**Navigation**  Expert → Application → E-mail → On/off messages

**Description** Specify who should receive e-mails when "on"/"off" events occur (for digital inputs or maths channels).

 Only for inputs where "Save event" is set to "Yes".

---

### Recipient x

---

**Navigation**  Expert → Application → E-mail → On/off messages → Recipient x  
Direct access code:  
Recipient 1: 510115-000; Recipient 2: 510116-000

**Description** Select who should receive the e-mail.

**Options** Not used, E-mail address x

**Factory setting** Not used

---

### "Errors (Fxxx/Sxxx)" submenu

---

**Navigation**  Expert → Application → E-mail → Errors (Fxxx/Sxxx)

**Description** Specify who should receive e-mails when errors occur (Fxxx and Sxxx messages).

---

### Recipient x

---

**Navigation**  Expert → Application → E-mail → Errors → Recipient x  
Direct access code:  
Recipient 1: 510120-000; Recipient 2: 510121-000

**Description** Select who should receive the e-mail.

**Options** Not used, E-mail address x

**Factory setting** Not used

---

### "Maintenance required" (submenu)

---

**Navigation**  Expert → Application → E-mail → Maintenance required

**Description** Specify who should receive e-mails when maintenance is required (Mxxx messages).

---

### Recipient x

---

**Navigation**  Expert → Application → E-mail → Maintenance required → Recipient x  
Direct access code:  
Recipient 1: 510130-000; Recipient 2: 510131-000

**Description** Select who should receive the e-mail.

**Options** Not used, E-mail address x

**Factory setting** Not used

---



### "WebDAV Client" submenu

---

**Navigation**  Expert → Application → WebDAV Client

**Description**

All recorded data is transferred to an external WebDAV server (e.g., NAS). The format can be specified or selected via **"Setup → Advanced setup → System → External memory → Save as"**.

Parameter	Description	Direct access code
Enable	Switch WebDAV Client functionality on/off. When active, the device copies the saved measured values automatically to the configured server.  Only possible using the Ethernet interface! <b>Options:</b> No, Yes, Yes (SSL) <b>Factory setting:</b> No	472000-000
IP address	Enter the IP address of the WebDAV server.  A DNS name can also be used. <b>User entry:</b> IP address <b>Factory setting:</b> 0.0.0.0	472001-000
Port	This communication port is used to communicate with the WebDAV Server.  If the network is protected by a firewall, this port may have to be enabled. In this case, contact the network administrator. <b>User entry:</b> Numbers (max. 5 digits) <b>Factory setting:</b> 80	472002-000
User name	Input of the user name that can access the WebDAV server. <b>User entry:</b> Text (max. 20 characters)	472004-000
Password	Password for accessing the WebDAV server. <b>User entry:</b> Text (max. 20 characters)	472007-000
Directory	Enter the directory in which the data should be saved. <b>User entry:</b> Text (max. 120 characters)	472005-000
Save as	"Protected format": All data is stored in a manipulation-protected encrypted format. This data can only be visualized by the PC analysis software. "Open format": Data is stored in a CSV format, this can be opened by a number of different programs (Attention: no manipulation protection). <b>Options:</b> Protected format, Open format (*.csv) <b>Factory setting:</b> Protected format	472010-000

 Test the WebDAV client settings under **"Diagnostics → Simulation → WebDAV client"**.

### 16.1.6 "Diagnostics" submenu

Device information and service functions for a quick device check.

 Only some of the diagnostic functions are available under Expert → Diagnostics! For other functions, see the Main menu → Diagnostics

---

## Actual diagnostics

---

**Navigation**

 Expert → Diagnostics → Actual diagnostics  
Direct access code: 050000-000

**Description**

Displays the current diagnostic message.

---

**Last diagnostics**

---

**Navigation**  Expert → Diagnostics → Last diagnostics  
Direct access code: 050005-000

**Description** Displays the last diagnostic message.

---

**Last restart**

---

**Navigation**  Expert → Diagnostics → Last restart  
Direct access code: 050010-000

**Description** Information as to when the device was last restarted (e.g., due to a power failure).

---

**"Event logbook" submenu**

---

**Navigation**  Expert → Diagnostics → Event logbook

**Description** Events such as a limit value violation and power failure are listed in the correct time sequence.

---

**"Device information" submenu**

---

**Navigation**  Expert → Diagnostics → Device information

**Description** Displays important device information.

---

**Device tag**

---

**Navigation**  Expert → Diagnostics → Device information → Device tag  
Direct access code: 000031-000

**Description** Individual device tag name/unit identifier (max. 32 characters).





---

**Serial number**



---

**Navigation**  Expert → Diagnostics → Device information → Serial number  
Direct access code: 000027-000

**Description** Individual serial number of the device. Provide these details when ordering spare parts or asking any questions about the unit.

Order code	
<b>Navigation</b>	 Expert → Diagnostics → Device information → Order code Direct access code: 000029-000
<b>Description</b>	<p>Displays the order code.</p> <p>The order code indicates the attribute of all the features of the product structure for the device and thus uniquely identifies the device. It can also be found on the nameplate.</p> <p> <b>Useful applications of the order code</b></p> <ul style="list-style-type: none"> <li>■ To order an identical replacement device.</li> <li>■ To check the ordered device features using the delivery note.</li> </ul>
Firmware version	
<b>Navigation</b>	 Expert → Diagnostics → Device information → Firmware version Direct access code: 000026-000
<b>Description</b>	<p>Displays the installed firmware version of the device. Please specify these details if you have any questions about the device.</p>
ENP version	
<b>Navigation</b>	 Expert → Diagnostics → Device information → ENP version Direct access code: 000032-000
<b>Description</b>	<p>Displays the version of the electronic nameplate. Please specify these details if you have any questions about the device.</p>
ENP device name	
<b>Navigation</b>	 Expert → Diagnostics → Device information → ENP device name Direct access code: 000020-000
<b>Description</b>	<p>Displays the ENP device name (electronic name plate). Please specify these details if you have any questions about the device.</p>
Device name	

---

<b>Navigation</b>	 Expert → Diagnostics → Device information → Device name Direct access code: 000021-000
<b>Description</b>	Displays the device name. Please specify these details if you have any questions about the device.

---

### Manufacturer ID

---

<b>Navigation</b>	 Expert → Diagnostics → Device information → Manufacturer ID Direct access code: 000022-000
<b>Description</b>	Displays the manufacturer ID. Please specify these details if you have any questions about the device.

---

### Manufacturer name

---

<b>Navigation</b>	 Expert → Diagnostics → Device information → Manufacturer name Direct access code: 000023-000
<b>Description</b>	Displays the manufacturer name. Please specify these details if you have any questions about the device.

---

### Firmware

---

<b>Navigation</b>	 Expert → Diagnostics → Device information → Firmware Direct access code: 009998-000
<b>Description</b>	Displays the installed firmware of the device. Please specify these details if you have any questions about the device.

---

### "Simulation" submenu

---

<b>Navigation</b>	 Expert → Diagnostics → Simulation
<b>Description</b>	Settings for simulation mode.

---

### Operating mode

---

<b>Navigation</b>	 Expert → Diagnostics → Simulation → Operating mode Direct access code: 010010-000
-------------------	--

<b>Description</b>	Normal operation: Unit plots the signals from the connected measurement points. Simulation: Instead of operating with the real measurement points the signals are simulated (using the actual settings).
<b>Options</b>	Normal operation, Simulation
<b>Factory setting</b>	Normal operation





[www.addresses.endress.com](http://www.addresses.endress.com)

---