



Level



Pressure



Flow



Temperature



Liquid  
Analysis



Registration



Systems  
Components



Services



Solutions

## Brief Operating Instructions

# Oxymax COS51D

Digital sensor for dissolved oxygen

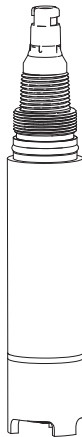

These instructions are Brief Operating Instructions.

For detailed information, please read the Operating Instructions and the special instructions on the supplied CD-ROM.

The complete device documentation comprises:

- these Brief Operating Instructions
- the Operating Instructions on the supplied CD-ROM
- if necessary, certificates and calibration protocols (depending on version).

KA00413C/07/EN/13.12  
71163823

**Endress+Hauser**







People for Process Automation





# 1 Documentation information

## Warnings

The structure, signal words and safety colors of the signs comply with the specifications of ANSI Z535.6 ("Product safety information in product manuals, instructions and other collateral materials").

Safety message structure	Meaning
 <b>DANGER</b> <b>Cause (/consequences)</b> Possible consequences if ignored ► Preventive measures	This symbol alerts you to a dangerous situation. Failure to avoid the situation <b>will</b> result in a fatal or serious injury.
 <b>WARNING</b> <b>Cause (/consequences)</b> Possible consequences if ignored ► Preventive measures	This symbol alerts you to a dangerous situation. Failure to avoid the situation <b>can</b> result in a fatal or serious injury.
 <b>CAUTION</b> <b>Cause (/consequences)</b> Possible consequences if ignored ► Preventive measures	This symbol alerts you to a dangerous situation. Failure to avoid this situation can result in minor or medium injury.
 <b>NOTICE</b> <b>Cause/situation</b> Possible consequences if ignored ► Action/note	This symbol alerts you to situations that can result in damage to property and equipment.

## Symbols used

-  1 This symbol indicates a cross reference to a defined page (e.g. p. 1).
-  2 This symbol indicates a cross reference to a defined figure (e.g. fig. 2).
-  Additional information, tips
-  Permitted or recommended
-  Forbidden or not recommended

---

# Table of contents

<b>1</b>	<b>Documentation information</b>	<b>2</b>
<b>2</b>	<b>Basic safety instructions</b>	<b>4</b>
2.1	Requirements for personnel	4
2.2	Designated use	4
2.3	Occupational safety	4
2.4	Operational safety	5
2.5	Product safety	5
<b>3</b>	<b>Sensor version for use in hazardous locations</b>	<b>5</b>
3.1	Special safety instructions COS51D-G*8*0*	5
3.2	Certificates and approvals	6
3.3	Notified body	6
3.4	Temperature classes	6
3.5	Declaration of conformity	7
<b>4</b>	<b>Installation</b>	<b>8</b>
4.1	Installation conditions	8
4.2	Installation instructions	8
4.3	Installation examples	9
<b>5</b>	<b>Wiring</b>	<b>13</b>
5.1	Quick wiring guide	13
5.2	Direct connection to the transmitter	14
5.3	Post-connection check	14
<b>6</b>	<b>Commissioning</b>	<b>14</b>
6.1	Function check	14
6.2	Polarization	15
6.3	Calibration	15

## 2 Basic safety instructions

### 2.1 Requirements for personnel

- ▶ Installation, commissioning, operation and maintenance of the measuring system must only be carried out by trained technical personnel.
- ▶ The technical personnel must be authorized by the plant operator to carry out the specified activities.
- ▶ The electrical connection may only be performed by an electrical technician.
- ▶ The technical personnel must have read and understood these Operating Instructions and must follow the instructions they contain.
- ▶ Measuring point faults may only be rectified by authorized and specially trained personnel.



Repairs not described in the enclosed Operating Instructions may only be carried out directly at the manufacturer's or by the service organization.

### 2.2 Designated use

The oxygen sensor is suitable for continuous measurement of dissolved oxygen in water.

Typical applications are:

- Measuring, monitoring and regulating the oxygen content in activated sludge basins.
- Monitoring the oxygen content in the sewage treatment plant outlet.
- Monitoring, measuring and regulating the oxygen content in public waters and fish farming water.
- Monitoring of oxygen enrichment in drinking water.

Any other use than the one described here compromises the safety of persons and the entire measuring system and is not permitted.

The manufacturer is not liable for damage caused by improper or non-designated use.

#### **NOTICE**

##### **Use in not specified applications**

Measurement errors and failures up to the breakdown of the measurement point possible

- ▶ Only use the product acc. to its specification.
- ▶ Observe the technical data of the nameplate.

### 2.3 Occupational safety

As the user, you are responsible for complying with the following safety conditions:

- Explosion protection regulations
- Installation instructions
- Local prevailing standards and regulations.

##### **Electromagnetic compatibility**

With regard to electromagnetic compatibility, this device has been tested in accordance with the applicable European standards for industrial applications.

The electromagnetic compatibility indicated only applies to a device that has been connected in accordance with the instructions in these Operating Instructions.

## 2.4 Operational safety

- ▶ Before commissioning the entire measuring point, make sure all the connections are correct. Ensure that electrical cables and hose connections are not damaged.
- ▶ Do not operate damaged products, and safeguard them to ensure that they are not operated inadvertently. Mark the damaged product as defective.
- ▶ If faults cannot be rectified, the products must be taken out of service and secured against unintentional commissioning.

### **⚠ CAUTION**

#### **The cleaning system is not switched off during calibration or maintenance activities**

Risk of injury due to medium or cleaning agent

- ▶ If a cleaning system is connected, switch it off before removing a sensor from the medium.
- ▶ If you are not switching off the cleaning system because you wish to test the cleaning function, wear protective clothing, goggles and gloves or take other appropriate measures.

## 2.5 Product safety

The product is designed to meet state-of-the-art safety requirements, has been tested and left the factory in a condition in which it is safe to operate. Relevant regulations and European standards have been observed.

# 3 Sensor version for use in hazardous locations

## 3.1 Special safety instructions COS51D-G\*8\*0\*

- The certified oxygen sensor Oxymax COS51D-G\*8\*0\* may only be connected via the measuring cable CYK10-G\*\*1 to approved intrinsically safe digital sensor circuits of the transmitter Liquiline M CM42-\*G\*. The electrical connection instruction must be followed.
- The measuring cable CYK10-G and its coupling must be protected from electrostatic charging, if installed through zone 0.
- The sensor may not be operated under process conditions where electrostatic charging is likely to occur. The designated use in media with a conductivity of at least 10 nS/cm can be assumed as electrostatic uncritical.
- Ex versions of digital sensors with Memosens technology are indicated by an orange-red ring on the plug-in head.
- The maximum permissible cable length is 100 m (330 ft).

## 3.2 Certificates and approvals

### 3.2.1 ATEX II 1G/IECEX Ex ia IIC T6 Ga

The inductive sensor-cable-plug-in system Memosens consisting of:

- oxygen sensor Oxymax W COS51D-G\*8\*0 and
- measuring cable CYK10-G\*\*1

is suitable for the use in explosion-hazardous locations acc. to the type-examination certificate BVS 04 ATEX E 121 X . The corresponding EC declaration of conformity is part of this document.

### 3.2.2 FM/CSA

#### Version COS51D-O\*\*\*\*

IS Class 1 Division 1 ABCD T4/T6

Class 1 Zone 0 AEx ia IIC T4/T6

## 3.3 Notified body

### DEKRA EXAM GmbH

Bochum (Germany)

## 3.4 Temperature classes

If the ambient temperatures indicated are observed, no temperatures which are impermissible for the temperature class in question will occur at the sensor.

	<b>Temperature class T6</b>
Ambient temperature $T_a$	-5 to +50 °C

### 3.5 Declaration of conformity

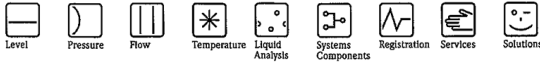

EG 156C/07/a3

## EG-Konformitätserklärung EC Declaration of Conformity CE Déclaration de Conformité

Endress+Hauser Conducta Gesellschaft für Mess- und Regeltechnik mbH+Co. KG  
Dieselstrasse 24, 70839 Gerlingen, Germany

erklärt in alleiniger Verantwortung, dass die Produkte  
declares in sole responsibility that the products  
déclare sous sa seule responsabilité que les produits

Memosens Sensoren / sensors / capteurs

**Oxymax**      **COS21D-\*12\*1**  
**Oxymax**      **COS22D-BA\*\*\*\*3**  
**Oxymax**      **COS51D-G\*8\*0**  
**CYK10-G\*\*1**

mit Kabel / with cable / avec câble

EG-Baumusterprüfbescheinigung:

**BVS 04 ATEX E 121 X**

EC type examination certificate:

Certificat de l'examen CE de type :

ausgestellt von / issued by / exposé par :

**DEKRA EXAM GmbH**

mit den Vorschriften folgender Europäischen Richtlinien übereinstimmen:  
are in conformity with the regulations of the following European Directives:  
sont conformes aux prescriptions et directives Européennes suivantes:

**94/9/EG**

(Geräte zur Verwendung in explosionsgefährdeten Bereichen)

(Equipment for use in potentially explosive atmospheres)

(Appareils et systèmes de protection en atmosphère explosive)

**2004/108/EG**

(Elektromagnetische Verträglichkeit)

(Electromagnetic Compatibility)

(Compatibilité électrotechnique)

Angewandte harmonisierte Normen oder normative Dokumente:

Applied harmonized standards or normative documents:

Normes harmonisées ou documents normatives appliquées:

**EN 60079-0:2009, EN 60079-11:2007, EN 60079-26:2007**

**EN 61326-1:2006, EN 61326-2-3:2006**

Benannte Stelle für QS-Überwachung:

DEKRA EXAM GmbH

Notified body for QA control:

Kennnummer / Identification number /

Organisme notifié pour l'assurance qualité :

numéro d'identification (0158)

Gerlingen, 2010-01-25

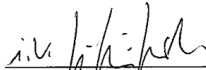
  
I.V. Jörg-Martin Müller  
Director Development

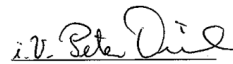
  
I.V. Peter Dierich  
Certifications and Approvals

**Endress+Hauser** 

People for Process Automation

## 4 Installation

### 4.1 Installation conditions

#### 4.1.1 Orientation

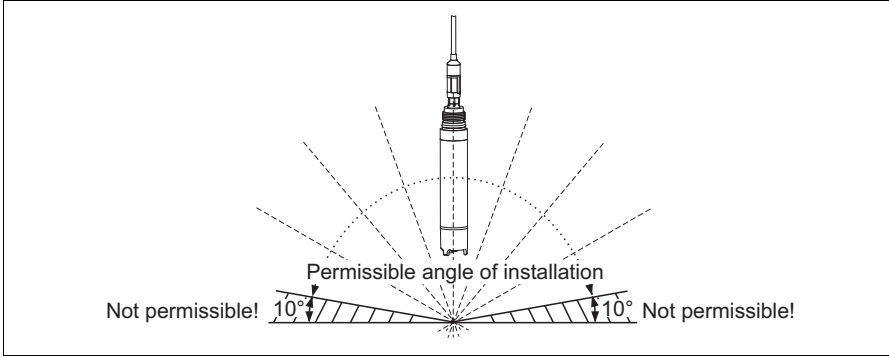

Fig. 1: Angle of installation

a0006741-en

A Recommended angle of installation: 0 ... 180 °

#### 4.1.2 Mounting location

- Select the installation location so that there is easy access for later calibration.
- Make sure that upright posts and assemblies are secured safely and vibration-free.
- Select an installation location which produces a typical oxygen concentration.

## 4.2 Installation instructions

### 4.2.1 Installing a measuring point

**i** For immersed operation, install the individual modules away from the basin on a solid base. Only carry out the final installation at the intended installation location.

For a complete installation of a measuring point, proceed as follows:

1. Install a retractable or a flow assembly (if used) into the process.
2. Connect the water supply to the rinse connections (if you use an assembly with cleaning function).
3. Install and connect the oxygen sensor.
4. Install an immersion or an suspension assembly (if used) into the process.

**NOTICE****No assembly used, sensor not correctly installed, grounding regulations not observed**

Risk of damaging the sensor cable, no protection to electromagnetic interferences

- ▶ For immersed operation, the sensor must be installed in an immersion assembly (e.g. CYA611). **Do not install the sensor suspended from the cable.**
- ▶ Screw the sensor into the assembly so that the cable is not twisted.
- ▶ Avoid exerting excessive tensile force on the cable (e.g. from jerky pulling).
- ▶ When using metallic assemblies and installation equipment, comply with national grounding regulations.
- ▶ Observe the sensor installation instructions of the Operating Instructions of the assembly used.

## 4.3 Installation examples

### 4.3.1 Immersion operation

#### Universal assembly holder and chain assembly

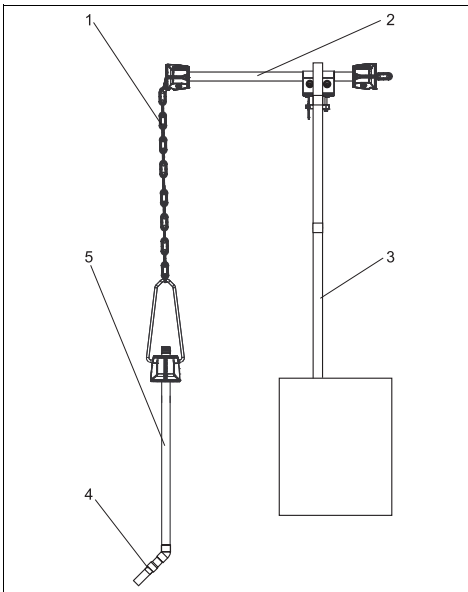

Fig. 2: Chain holder, rail mounted

- 1 Chain
- 2 Flexdip CYH112 holder
- 3 Rail
- 4 Oxymax sensor
- 5 Flexdip CYA112 wastewater assembly

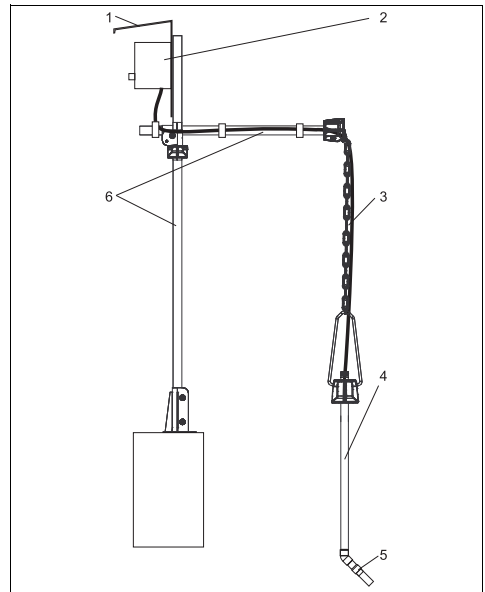
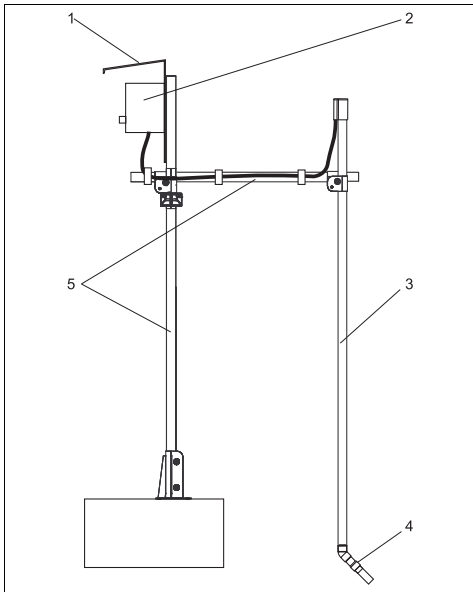

Fig. 3: Chain holder, mounted to a post

- 1 Weather protection cover
- 2 Controller / transmitter
- 3 Chain
- 4 Flexdip CYA112 wastewater assembly
- 5 Oxymax sensor
- 6 Flexdip CYH112 holder

## Universal assembly holder and fixed immersion assembly



a0013513

Fig. 4: Assembly holder with immersion tube

- 1 Weather protection cover
- 2 Controller / transmitter
- 3 Immersion assembly Flexdip CYA112
- 4 Oxymax sensor
- 5 Assembly holder Flexdip CYH112

### Basin rim mounting with immersion tube

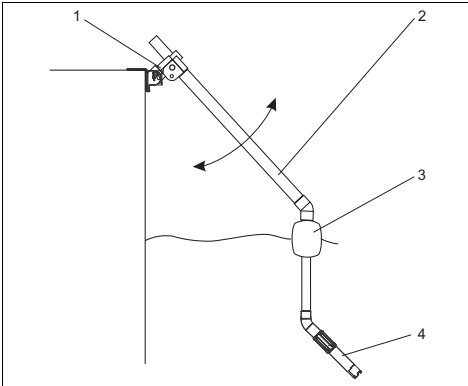

a0013693

Fig. 5: Basin rim mounting

- 1 Pentulum holder CYH112
- 2 Assembly Flexdip CYA112
- 3 Float of assembly CYA112
- 4 Oxymax sensor

### Floating body

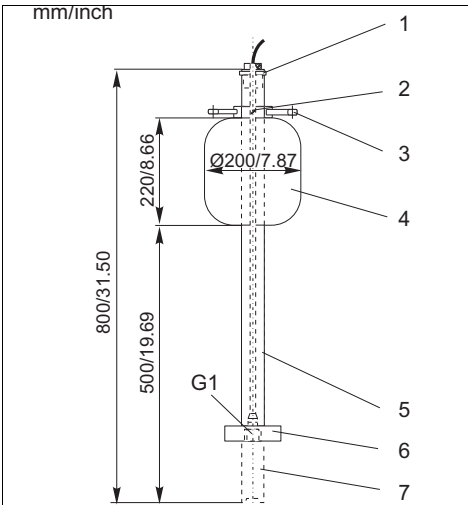

a0004108-en

Fig. 6: Floating body

- 1 Cable route with strain relief and rain protection
- 2 Mounting ring for ropes and chains with locking screw
- 3 Lugs Ø15, 3 x 120 ° for anchoring
- 4 Saltwater-resistant plastic float
- 5 Pipe 40x1, stainless steel 1.4571 (AISI 316Ti)
- 6 Shock absorber and weight
- 7 Oxygen sensor

### 4.3.2 Flow assembly

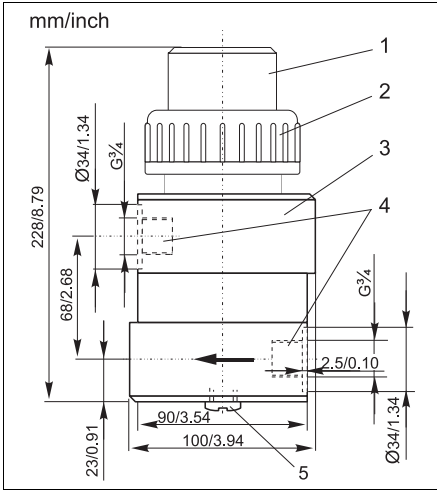

Fig. 7: Flow assembly COA250-B

- 1 Screw-in part for sensor
- 2 Screw ring
- 3 Meter body
- 4 Connection thread G $\frac{3}{4}$
- 5 Dummy plug (connection for spray head COR3)

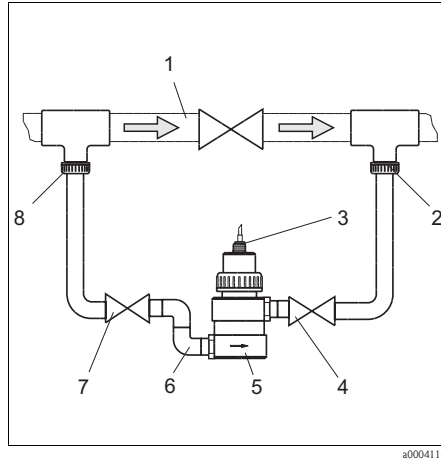

Fig. 8: Bypass installation

- 1 Main line
- 2 Medium return
- 3 Oxygen sensor
- 4, 7 Manually actuated or solenoid valves
- 5 Flow assembly COA250-B
- 6 90° pipe bracket
- 8 Medium removal

### 4.3.3 Retractable assembly

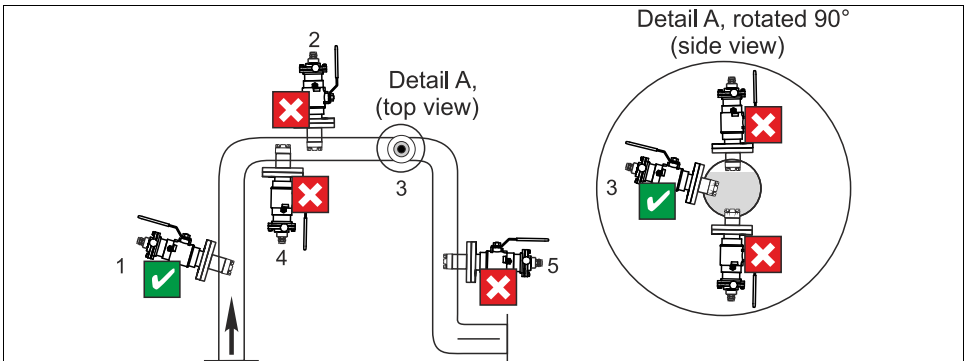
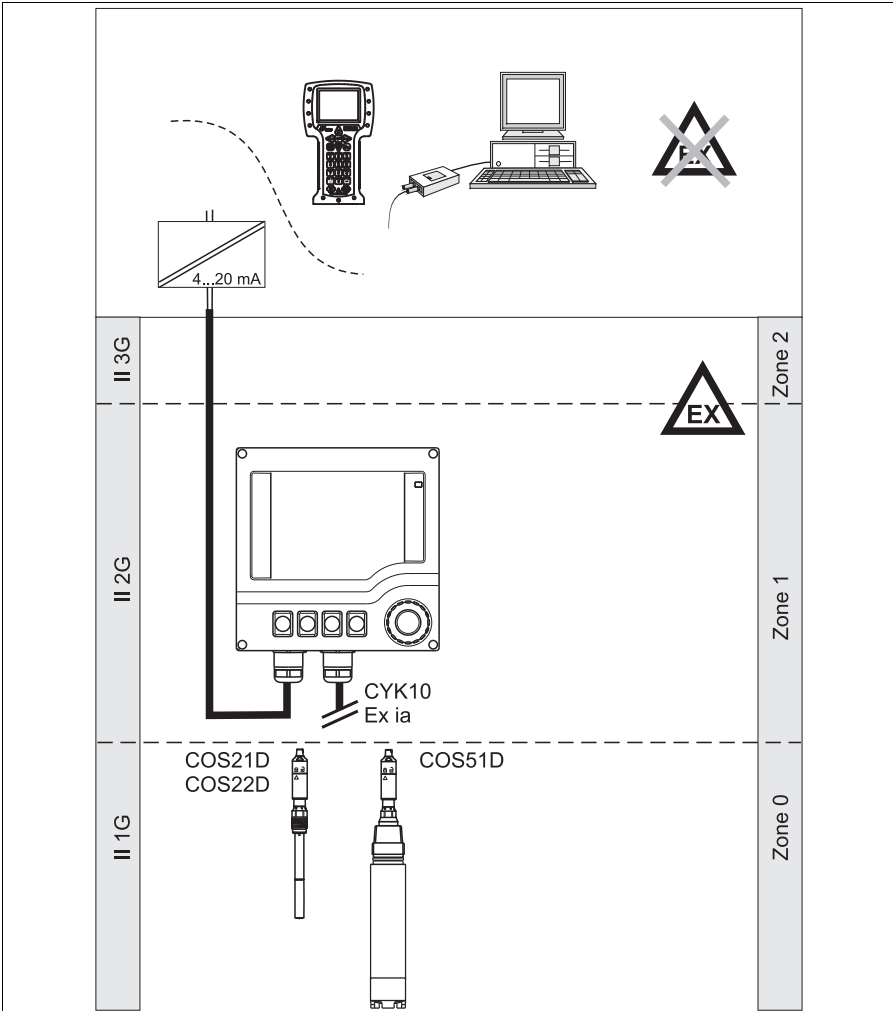

Fig. 9: Permissible and impermissible sensor installation positions with retractable assembly COA451

- 1 Ascending pipe, best position
- 2 Horizontal pipe, sensor top down, impermissible due to air cushion or foam bubble forming
- 3 Horizontal pipe, installation with permissible installation angle (acc. to sensor version)
- 4 Overhead installation, critical due to possible sediment buildup on fluorescence cap
- 5 Down pipe, impermissible

# 5 Wiring

## 5.1 Quick wiring guide



a0010056

Fig. 10: Connection in hazardous locations

## 5.2 Direct connection to the transmitter

### ⚠ WARNING

#### Device is energized

Improper connection can cause injury or death.

- ▶ The electrical connection must only be carried out by a certified electrician.
- ▶ Technical personnel must have read and understood the instructions in this manual and must adhere to them.
- ▶ **Prior to beginning** any wiring work, make sure voltage is not applied to any of the cables.

The sensor is connected to the transmitter via the measuring cable CYK10.

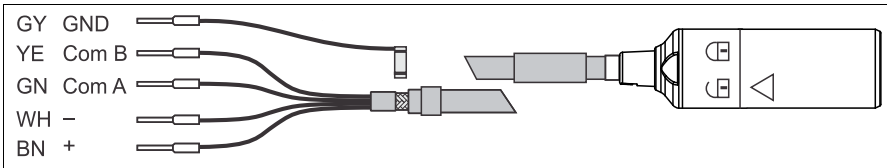

Fig. 11: Measuring cable CYK10

a0003350

## 5.3 Post-connection check

Instrument status and specifications	Remarks
Are the sensor, assembly, junction box or cable damaged?	Visual inspection
Electrical connection	Remarks
Are the installed cables strain-relieved and not twisted ?	
Long enough length of cable core stripped and correct in terminal?	Check seating (pull slightly)
Are all the screws terminals properly tightened ?	Tighten
Are all the cable entries installed, tightened and sealed ?	For cable entries lateral: cable loops downwards for water to be able to drip off.
Are all the cable entries installed downwards or lateral ?	

# 6 Commissioning

## 6.1 Function check

Before first commissioning, check if:

- the sensor is correctly installed
- the electrical connection is correct.

If using an assembly with automatic cleaning, check the correct connection of the cleaning agent (e.g. water or air).

### **▲ WARNING**

#### **Escaping process medium**

Risk of injury from high pressure, high temperatures or chemical hazards

- ▶ Before applying compressed air to an assembly with cleaning facility, make sure the connections are correctly fitted.
- ▶ Do not install the assembly in the process if you cannot make the correct connection reliably.

## **6.2 Polarization**

### **NOTICE**

#### **Measurement errors due to environmental conditions**

- ▶ Urgently protect the sensor from strong sunlight.
- ▶ Make sure you comply with the instructions for commissioning and calibration in the Operating Instructions of the transmitter.

The sensor was tested in the factory for perfect functionality and is supplied ready for operation.

To prepare for calibration, proceed as follows:

1. Remove the sensor protective cap.
2. Place the externally dry sensor in atmospheric air. The air should be saturated with water vapour. Therefore, install the sensor as close to the water surface as possible. When calibrating the sensor membrane, make sure the membrane remains dry. Therefore, avoid any direct contact with the water surface.
3. Connect the sensor to the transmitter and switch on the transmitter.
4. Switch-on the transmitter.  
If you connect the sensor to the transmitter, polarization is automatically performed after switching on the transmitter.
5. Wait for the polarization time to end.

## **6.3 Calibration**

Calibrate the sensor (calibration type "Air") immediately after it's polarization.

1. Remove the sensor from the medium.
2. Clean the outside of the sensor with a damp cloth.  
Then dry the sensor membrane e.g. by using a tissue.
3. Then wait while the sensor adjusts to the temperature of the ambient air. This takes about 20 minutes. Check that the sensor is not in direct sunlight during this time.
4. If the measured value display on the transmitter is stable, carry out the calibration in accordance with the Operating Instructions of the transmitter.
5. Place the sensor in the medium again.

 Make sure you comply with the instructions for calibration in the Operating Instructions of the transmitter.

[www.addresses.endress.com](http://www.addresses.endress.com)

---

**Endress+Hauser**   
People for Process Automation

---

KA00413C/07/EN/13.12  
FM10

