

Operating Instructions

Tankvision Multi Scan NXA83B

Tank Gauging
Installation and Maintenance Manual





A0023555

- Make sure the document is stored in a safe place such that it is always available when working on or with the device
- Avoid danger to individuals or the facility: read the "Basic safety instructions" section carefully, as well as all other safety instructions in the document that are specific to working procedures

The manufacturer reserves the right to modify technical data without prior notice. The Endress+Hauser sales organization will supply you with current information and updates to these instructions.

Change history

BA01290G/01.14

- Valid for software version: 3.0.10
- Initial version

BA01290G/02.15

- Valid for software version: 3.0.12
- Changes to the previous version:
 - Change of order code structure

BA01290G/03.16

- Valid for software version: 3.1.0 and 4.0.0
- Changes to the previous version:
 - Old V1 support and simplified configuration

BA01290G/04.18

- Valid for software version: 3.4.0 and 4.4.0
- Changes to the previous version:
 - Changes to V1 Driver and GBT calculations

BA01290G/05.21

- Valid for software version: 5.0.0
- Changes to the previous version:
 - Migration to Windows 10 IoT operating system

BA01290G/06.23-00

- Valid for software version: 5.1.0
- Changes to the previous version:
 - Introduction of a new Webserver

BA01290G/07.25-00

- Valid for software version: 5.1.0
- Changes to the previous version:
 - Chapter 6 "Communication Lights" added

Table of contents

1	About this document	6
1.1	Document function	6
1.2	Symbols	6
1.3	List of abbreviations	7
1.4	Documentation	7
1.5	Registered trademarks	7
2	Basic safety instructions	9
2.1	Requirements for the personnel	9
2.2	Intended use	9
2.3	Workplace safety	10
2.4	Operational safety	10
2.5	Product safety	10
2.6	IT security	11
3	Incoming acceptance and product identification	12
3.1	Incoming acceptance	12
3.2	Product identification	12
3.3	Order code and device version	13
4	Introduction	14
4.1	Device Support and Compatibility	15
4.2	Typical Connections	16
5	Installation	17
5.1	Mechanical Installation	17
5.2	Electrical Installation	18
5.3	Network and USB connections	19
5.4	Serial Ports	20
5.5	LED Module	20
5.6	Interface Connection Details	21
6	Communication Lights	26
6.1	Tankvision Multi Scan Communication Lights	26
6.2	Interpreting Communications Status	26
6.3	Input communications	27
6.4	Output interfaces	27

1 About this document

1.1 Document function

This manual is giving detailed information on the system capabilities and architecture. It supports project and sales engineers in designing the system architecture during acquisition and execution phase. Furthermore during operation time of the system all servicing personnel in need of detailed knowledge about the system capabilities.

1.2 Symbols

1.2.1 Safety symbols

DANGER

This symbol alerts you to a dangerous situation. Failure to avoid this situation will result in serious or fatal injury.

WARNING

This symbol alerts you to a potentially dangerous situation. Failure to avoid this situation can result in serious or fatal injury.

CAUTION

This symbol alerts you to a potentially dangerous situation. Failure to avoid this situation can result in minor or medium injury.

NOTICE

This symbol alerts you to a potentially harmful situation. Failure to avoid this situation can result in damage to the product or something in its vicinity.

1.2.2 Symbols for certain types of information

Tip

Indicates additional information



Reference to documentation



Notice or individual step to be observed

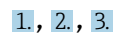

Series of steps



Result of a step

1.2.3 Symbols in graphics

1, 2, 3, ...

Item numbers



Series of steps

A, B, C, ...

Views

1.3 List of abbreviations

- BPM
Bi-Phase Mark
- LPG
Liquefied Petroleum Gas

1.4 Documentation

 For an overview of the scope of the associated Technical Documentation, refer to the following:

- *Device Viewer* (www.endress.com/deviceviewer): Enter the serial number from the nameplate
- *Endress+Hauser Operations app*: Enter serial number from nameplate or scan matrix code on nameplate.

The following document types are available in the Downloads area of the Endress+Hauser website (www.endress.com/downloads), depending on the device version:

Document type	Purpose and content of the document
Technical Information (TI)	Planning aid for your device The document contains all the technical data on the device and provides an overview of the accessories and other products that can be ordered for the device.
Brief Operating Instructions (KA)	Guide that takes you quickly to the 1st measured value The Brief Operating Instructions contain all the essential information from incoming acceptance to initial commissioning.
Operating Instructions (BA)	Your reference document The Operating Instructions contain all the information that is required in various phases of the life cycle of the device: from product identification, incoming acceptance and storage, to mounting, connection, operation and commissioning through to troubleshooting, maintenance and disposal.
Description of Device Parameters (GP)	Reference for your parameters The document provides a detailed explanation of each individual parameter. The description is aimed at those who work with the device over the entire life cycle and perform specific configurations.
Safety instructions (XA)	Depending on the approval, safety instructions for electrical equipment in hazardous areas are also supplied with the device. These are an integral part of the Operating Instructions.  The nameplate indicates which Safety Instructions (XA) apply to the device.
Supplementary device-dependent documentation (SD/FY)	Always comply strictly with the instructions in the relevant supplementary documentation. The supplementary documentation is a constituent part of the device documentation.

1.5 Registered trademarks

Modbus®

Registered trademark of SCHNEIDER AUTOMATION, INC.

Microsoft®, Windows® and Edge®

Microsoft®, Windows®, Edge® and the Microsoft logo are registered trademarks of the Microsoft Corporation.

Java®

Registered trademark of Sun Microsystems, Inc.

Mozilla® Firefox®

Registered trademark of the Mozilla Foundation

Enraf, Honeywell, Rosemount, Emerson, L&J, GPE, Varec, Ensite are registered trademarks and trademarks of these organizations and companies.

All other marks are property of their respective owners.

2 Basic safety instructions

2.1 Requirements for the personnel

The personnel for installation, commissioning, diagnostics and maintenance must fulfill the following requirements:

- ▶ Trained, qualified specialists must have a relevant qualification for this specific function and task.
- ▶ Are authorized by the plant owner/operator.
- ▶ Are familiar with federal/national regulations.
- ▶ Before starting work, read and understand the instructions in the manual and supplementary documentation as well as the certificates (depending on the application).
- ▶ Follow instructions and comply with basic conditions.

The operating personnel must fulfill the following requirements:

- ▶ Are instructed and authorized according to the requirements of the task by the facility's owner-operator.
- ▶ Follow the instructions in this manual.

2.2 Intended use

2.2.1 Applications

Inventory control

By using Tankvision Multi Scan to monitor the tank level and stored volume of valuable liquids remotely, owners or operators of tank farms or terminals for petroleum products and chemicals (liquids) can visualize the volume of the stored medium in real time. The data can be used to plan the inventory and distribution. The data can also be used to manage tank farm operations like pumping or transferring products. Tankvision has its unique concept using network technology. Without using proprietary software, the users can visualize and manage their valuable liquids stored in the tanks by a web browser. Tankvision Multi Scan is a flexible and cost effective solution due to its scalable architecture. The application coverage goes from small depots with only a few tanks up to refineries.

Inventory Calculations

Tankvision Multi Scan calculates based on measured variables and tank capacity tables:

- Observed or gross volumes
- Net volumes
- Mass

of products like:

- Hydrocarbons
- Liquefied gases
- Asphalt

They are corrected according to international standards, including API/ASTM tables 5A, 5B/6, 53A, 53B/54, 23/24, LPG.

This includes temperature corrections at 15 °C (60 °F) and alternative temperatures. Additionally, available pump able volumes and water volume are calculated.

Remote configuration of measuring equipment

Some on-site operations can be avoided using remote configuration of measuring equipment during commissioning or maintenance (the availability of this feature may depend on the system configuration).

Application areas

- Tank farms in refineries
- Ship loading terminals
- Marketing and distribution terminals
- Pipeline terminals
- Logistic terminals for tanks storing products like crude oils, refined white and black products, chemicals, LPG

2.3 Workplace safety

For work on and with the device:

- ▶ Wear the required personal protective equipment according to federal/national regulations.

Before connecting or disconnecting the device:

- ▶ Switch off the supply voltage.

2.4 Operational safety

Risk of injury!

- ▶ Operate the device only if it is in proper technical condition, free from errors and faults.
- ▶ The operator is responsible for interference-free operation of the device.

Modifications to the device

Unauthorized modifications to the device are not permitted and can lead to unforeseeable dangers!

- ▶ If modifications are nevertheless required, consult with the manufacturer.

Repair

To ensure continued operational safety and reliability:

- ▶ Carry out repairs on the device only if they are expressly permitted.
- ▶ Observe federal/national regulations pertaining to the repair of an electrical device.
- ▶ Use only original spare parts and accessories.

2.5 Product safety

This state-of-the-art device is designed and tested in accordance with good engineering practice to meet operational safety standards. It left the factory in a condition in which it is safe to operate.

Furthermore, the device meets the legal requirements of the applicable UK regulations (Statutory Instruments). These are listed in the UKCA Declaration of Conformity along with the designated standards.

By selecting the order option for UKCA marking, Endress+Hauser confirms a successful evaluation and testing of the device by affixing the UKCA mark.

Contact address Endress+Hauser UK:

Endress+Hauser Ltd.

Floats Road Manchester M23 9NF

United Kingdom

www.uk.endress.com

2.6 IT security

The manufacturer warranty is valid only if the product is installed and used as described in the Operating Instructions. The product is equipped with security mechanisms to protect it against any inadvertent changes to the settings.

IT security measures, which provide additional protection for the product and associated data transfer, must be implemented by the operators themselves in line with their security standards.

3 Incoming acceptance and product identification

3.1 Incoming acceptance

On receipt of the delivery:

1. Check the packaging for damage.
 - ↳ Report all damage immediately to the manufacturer.
Do not install damaged components.
2. Check the scope of delivery using the delivery note.
3. Compare the data on the nameplate with the order specifications on the delivery note.
4. Check the technical documentation and all other necessary documents, e.g. certificates, to ensure they are complete.

 If one of the conditions is not satisfied, contact the manufacturer.

3.2 Product identification

The following options are available for identification of the device:

- Nameplate specifications
- Order code with breakdown of the device features on the delivery note
- Enter the serial number from the nameplate in the *Device Viewer* (www.endress.com/deviceviewer): all the information about the device and an overview of the Technical Documentation supplied with the device are displayed.
- Enter the serial number on the nameplate into the *Endress+Hauser Operations App* or scan the 2-D matrix code (QR code) on the nameplate with the *Endress+Hauser Operations App*: all the information about the device and the technical documentation pertaining to the device is displayed.

3.2.1 Nameplate

Do you have the correct device?

The nameplate provides you with the following information on the device:

- Manufacturer identification, device designation
 - Order code
 - Extended order code
 - Serial number
 - Tag name (TAG) (optional)
 - Technical values, e.g. supply voltage, current consumption, ambient temperature, communication-specific data (optional)
 - Degree of protection
 - Approvals with symbols
 - Reference to Safety Instructions (XA) (optional)
- ▶ Compare the information on the nameplate with the order.

3.2.2 Manufacturer address

Endress+Hauser SE+Co. KG
Hauptstraße 1
79689 Maulburg, Germany
Place of manufacture: See nameplate.

3.3 Order code and device version



To find out the version of your device, enter the order code indicated on the nameplate in the search screen at the following address:

www.products.endress.com/order-ident

4 Introduction

The Multi Scan NXA83B is a configurable system designed for tank gauging and tank inventory management systems. It has been designed to fulfil a number of requirements some of which are listed below:

- Act as a foreign device gateway allowing old legacy equipment and devices with proprietary interfaces to interface with modern devices using OPC and Ethernet Technology.
- To provide a complete tank gauging and tank inventory management system for small sites. It can interface directly with a wide variety of tank gauging devices and provide a number of communication links to host devices. The Multi Scan NXA83B polls the field instruments maintaining an in-memory database of live and calculated data whilst also being able to service host computers for data.
- Up to 20 serial interfaces can be provided, capable of supporting a range of different electrical interfaces such as RS232, RS485, BPM, Current Loop etc. An Ethernet port and two USB ports are also provided.

The Multi Scan NXA83B is available as 19 in Rack Mount version. An option is to have a 7 in touch screen built into the front of the device to view and navigate through the different display options.



A0052569

 1 19 in Rack Mount

The Multi Scan is available in the following versions:

- 1 to 4 serial ports
- 1 to 12 serial ports
- 1 to 20 serial ports (16 in or outputs and 4 outputs)

The ports can be configured to be either inputs (from the field or host ports) or outputs (to host systems or slave ports). For the version 1 to 20 serial ports, 4 ports are reserved for outputs only.

4.1 Device Support and Compatibility

The Multi Scan NXA83B is designed to interface to the following gauge and transmitter types:

- Endress+Hauser:
 - NMR81 and NMR84 Micropilot
 - NRF81 Tankside Monitor
 - NMS80 and NMS81 Proservo
 - NRF590 Tank Side Monitor
 - NMS5 Proservo
- Enraf:
 - 811 Servo Gauge
 - 813 Servo Gauge
 - 854 Servo Gauge
 - 872 Radar Gauge
 - 873 Radar Gauge
 - 865 Temperature Selector
 - 911 Flexline Radar Gauge
- Whessoe:
 - 1311 Transmitter/1071 Outstation
 - 1315 Transmitter/2006 Mechanical float gauge, 1140 Servo gauge
 - ITG 50/60/70 Servo gauges
- Rosemount ("Saab"):
 - TRL/2
 - Rex
 - Pro Radar Gauges
- Motherwell:
 - 2800 Servo Gauge
- Varec:
 - 1800/1900 Mark/Space Transmitters

Additional protocols and variants upon request.

A range of gauge commands are supported but the availability of these commands depends on the gauge types. The host and field communication parameters are configurable, however, a number of the above devices operate with fixed parameters.

4.2 Typical Connections

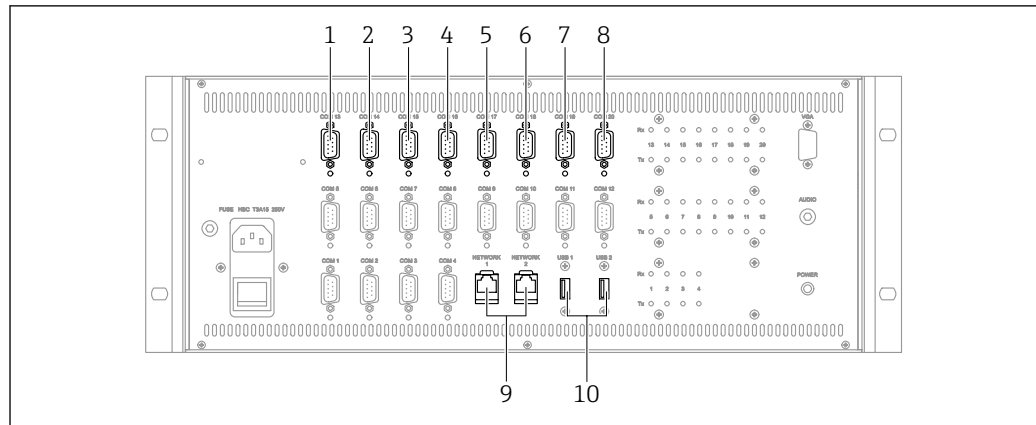

A0047372

- 1 "Saab" TRL/2
- 2 Ethernet (OPC)
- 3 Enraf BPM
- 4 DCS (Modbus)
- 5 Modbus Tank Gauges
- 6 Enraf CIU 858
- 7 Whessoe 550
- 8 Varec Mark/Space
- 9 Ethernet
- 10 USB

5 Installation

5.1 Mechanical Installation

The Multi Scan NXA83B is available as a 19 in Rack Mount. All versions of the Multi Scan NXA83B are intended for installation within a building and should not be mounted in hazardous areas.

The Rack mount version is housed in an aluminium 4U 19 in case, which has 4 front fixing holes suitable for M6 bolts.

All power and signal connectors are located on the rear panel of the enclosure.

5.1.1 Dimensions

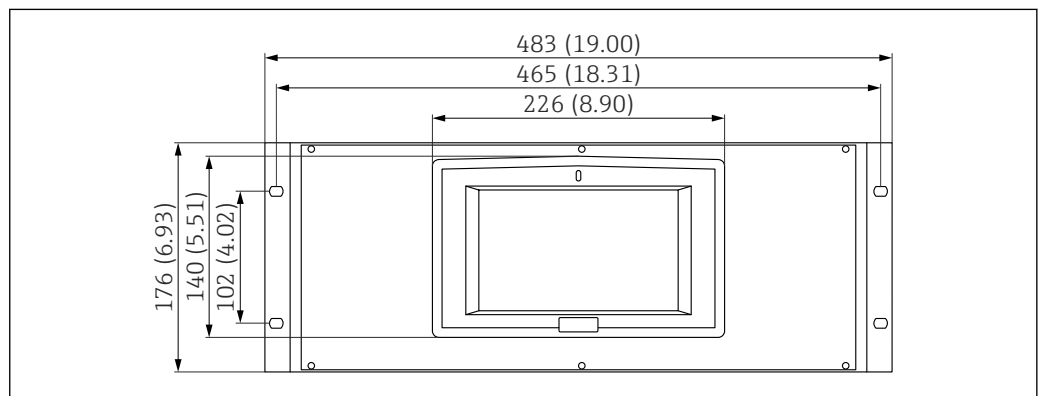

A0046364

Unit of measurement mm (in)

Depth of enclosure: 315 mm (12.4 in)

5.1.2 Backplane assembly variant 4 channels

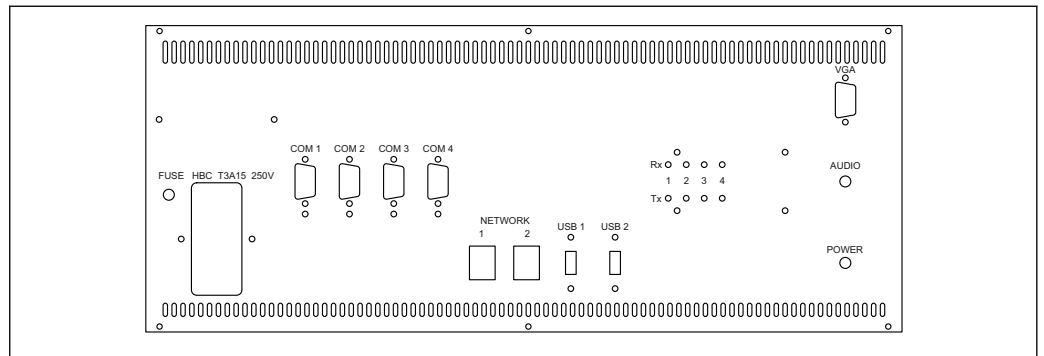

A0046361

5.1.3 Backplane assembly variant 12 channels

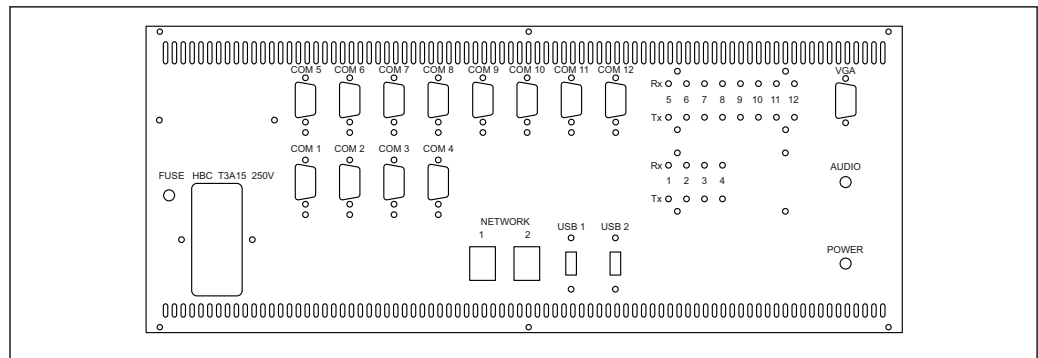

A0046362

5.1.4 Backplane assembly variant 20 channels

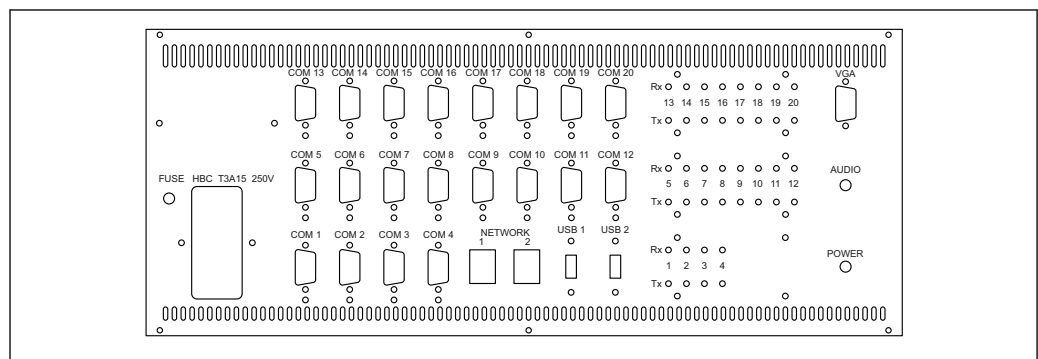

A0046363

5.2 Electrical Installation

The Multi Scan NXA83B requires connection to a mains power supply with the following characteristics:

Voltage

100 to 240 V_{AC}

Frequency

47/63 Hz

Current

max. 0.8 A

Power

40 W

The Multi Scan NXA83B contains a 20 × 5 mm (0.79 × 0.2 in) cartridge fuse protecting the mains input. The fuse is rated at 3.15 A, time delay (antisurge or slow blow). The fuse must be suitable for use at 240 V_{AC}.

The mains should be supplied with a standard IEC lead (kettle plug) and plugged into the socket shown below. A mains switch is provided to turn power on/off to the Multi Scan NXA83B. The socket, switch and fuse are found on the rear panel.

There is a GREEN power indication LED which will be permanently illuminated whilst power is applied to the Multi Scan NXA83B. The LED mounted on the same panel as the main power connector.

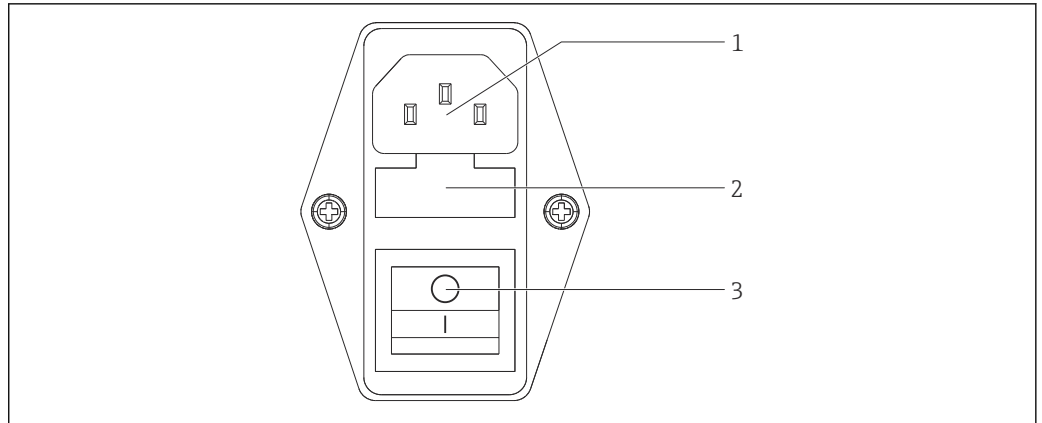

A0058946

- 1 IEC Socket
- 2 Fuse
- 3 Mains Switch

5.3 Network and USB connections

The Multi Scan NXA83B has one Ethernet network connector and two USB connectors mounted on rear panel of the unit.

The Ethernet connector accepts RJ45 network cables and has the standard PC pin assignment. To connect directly to another PC requires a cross-over network cable, whilst to connect to a hub, switch or similar requires a standard cable.

The network port is required to configure the Multi Scan NXA83B, using the Tankvision Multi Scan Configurator software, via a remote desktop session. It may also be used to connect to host systems using the Modbus TCP and datacon protocols.

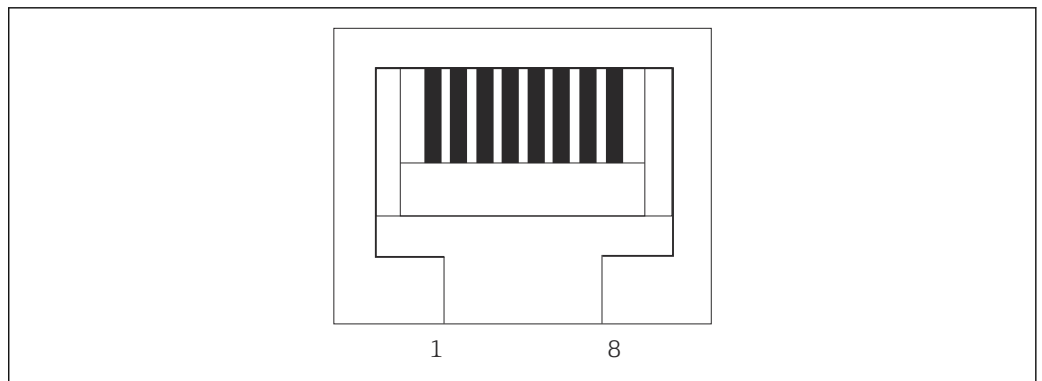

A0058947

Pin	Signal name
1	TX+
2	TX-
3	RX+
4	No connect
5	No connect
6	RX-
7	No connect
8	No connect

The 2 USB connectors allow a range of peripheral devices to be connected to the Multi Scan NXA83B, such as flash memory 'sticks', printers and modems. They are compliant with the USB 2.0 specification.

5.4 Serial Ports

The Multi Scan NXA83B has a range of serial ports for connection to field gauges or host computers. The actual number of ports available depends on the model type:

- **4 Port Rack Mount:** 4 Ports, COM 1 – COM 4, as field or host ports with any protocol
- **12 Port Rack Mount:** 12 Ports, COM 1 – COM 12, as field or host ports with any protocol
- **20 Port Rack Mount:** 20 Ports, COM 1 – COM 20, as field or host ports with any protocol

 W&M systems will use COM 4 to connect to the touchscreen.

The serial ports will use the RS232 hardware specification by default. However a range of plug in cards is available to support other hardware interfaces.

Supported boards include:

- Endress+Hauser V1
- Enraf Bi-Phase Mark
- Whessoe Current Loop
- HART
- Varec Mark/Space
- Saab TRL/2
- L&J Tankway
- RS485/RS422

Usually the interfaces will be specified at time of purchase, and the Multi Scan NXA83B will be supplied with all required boards installed.

All serial ports are located on the rear panel of the unit. Only ports that have been purchased (and licensed) will have connectors, all other ports will be fitted with blanking plates.

5.5 LED Module

The Multi Scan NXA83B has an LED module which consists of a bank of eight pairs of LEDs, one pair for each of the serial ports, to indicate communication activity. One LED is transmit and the other one is receive.

Each pair of LEDs has a serial connector from the RS232 port on the mother board, and another going to the interface board.

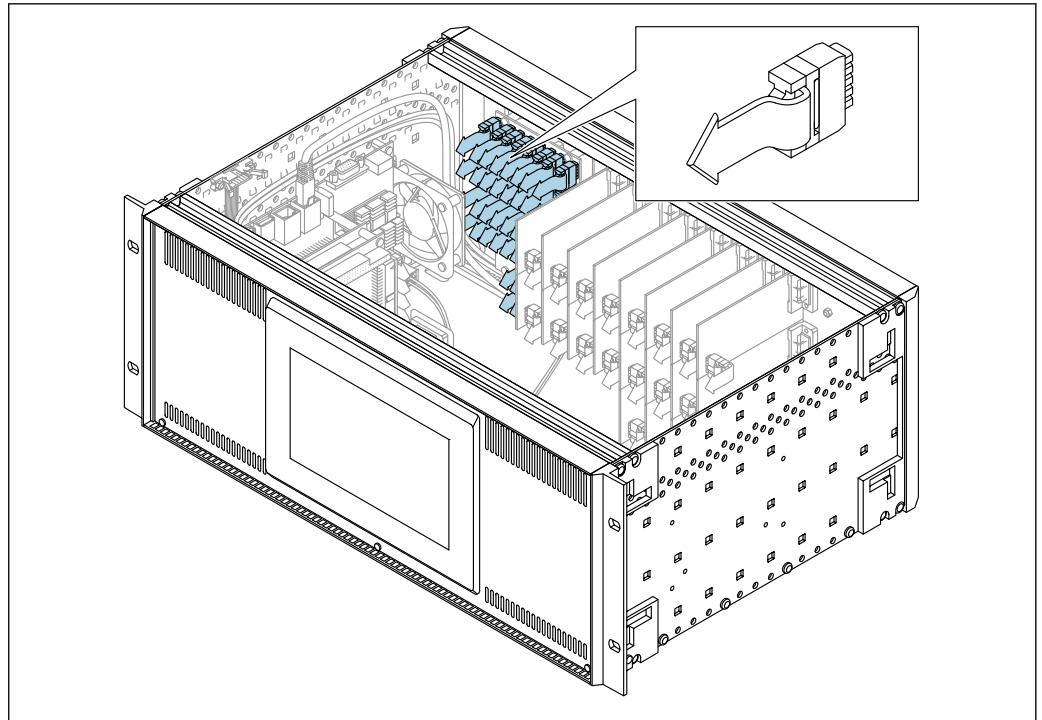

A0047422

5.6 Interface Connection Details

5.6.1 Internal Relay Board Connection

Connector Type: 9 Way D-Type socket

Interface connection:

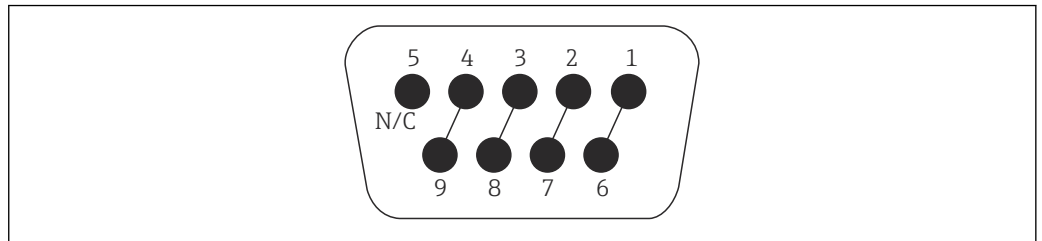

A0058948

Pin	Relay contacts
1/6	Relay 1 contacts
2/7	Relay 2 contacts
3/8	Relay 3 contacts
4/9	Relay 4 contacts

Each contact pair may be configured as be N/O or N/C.

5.6.2 RS232 Connection

Connector Type: 9 Way D-Type plug

Interface connection:

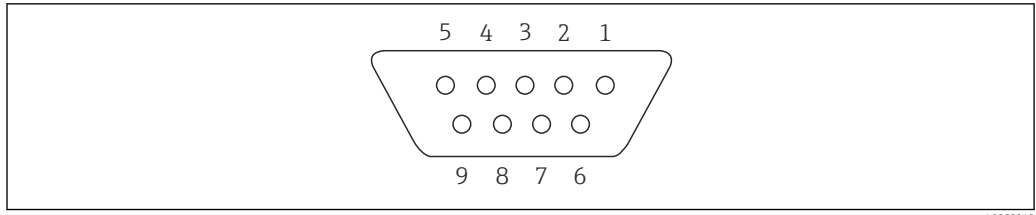

A0058949

Pin	RS232
2	RXD
3	TXD
5	Ground
7	RTS
8	CTS

5.6.3 RS485/RS422 Connection

Connector Type: 9 Way D-Type (MALE) plug

Interface connection:

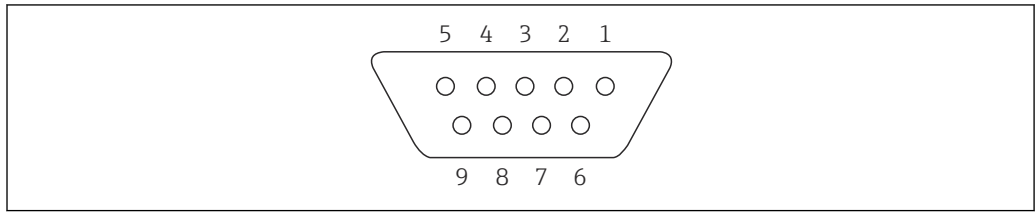

A0058949

Pin	RS485 2 Wire	RS485/RS422 4 Wire
1	-	T-
2	-	T+
3	TD+	R+
4	TD-	R-
5	Ground	Ground

5.6.4 Enraf BPM Connection

Connector Type: Phoenix Connector, Screw Terminal

Interface connection:

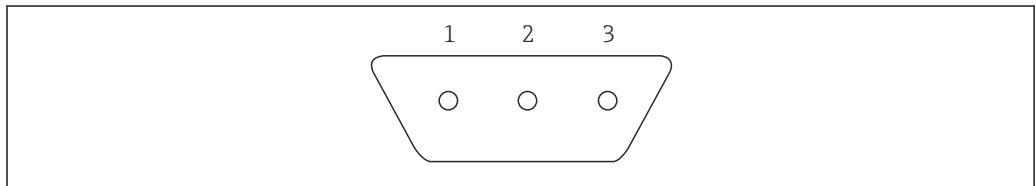

A0058950

Pin	Enraf BPM
1	TL1
2	Screen
3	TL2

5.6.5 Saab TRL/2 Connection

Connector Type: Phoenix Connector, Screw Terminal

Interface connection:

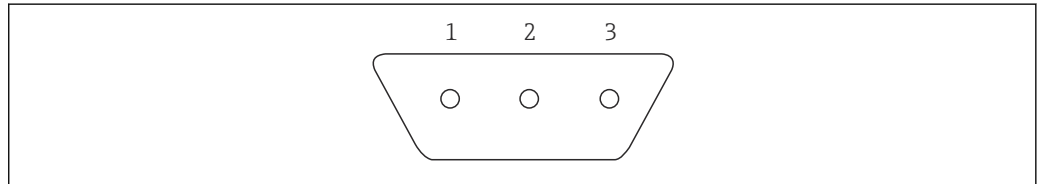

A0058950

Pin	Saab TRL/2
1	FB1
2	Screen
3	FB2

5.6.6 Whessoe Current Loop Connection

Connector Type: Phoenix Connector, Screw Terminal

Interface connection:

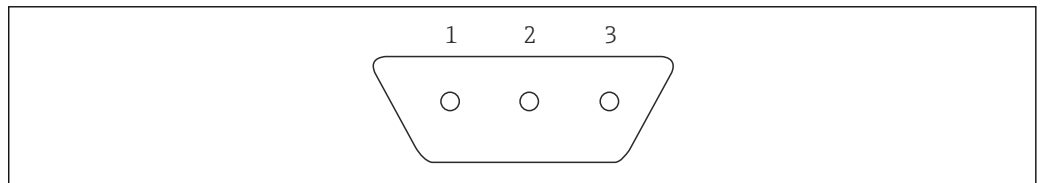

A0058950

Pin	Whessoe 20 mA
1	Loop +
2	Screen
3	Loop -

5.6.7 HART Connection

Connector Type: Phoenix Connector, Screw Terminal

Interface connection:

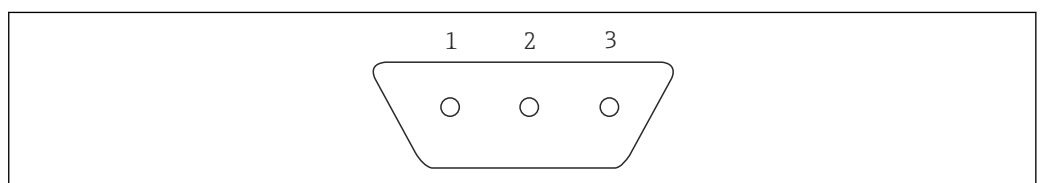

A0058950

Pin	HART
1	Loop -
2	Screen
3	Loop +

5.6.8 L&J Tankway Connection

Connector Type: 9 Way D-Type socket

Interface connection:

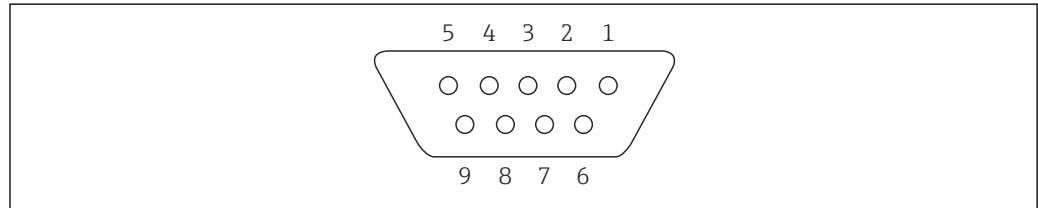

A0058949

Pin	Function
1/6	Power
2/7	Computer
3/8	Encoder
5/9	Ground

5.6.9 Varec Mark/Space Connection

Connector Type: 9 Way D-Type socket

Interface connection:

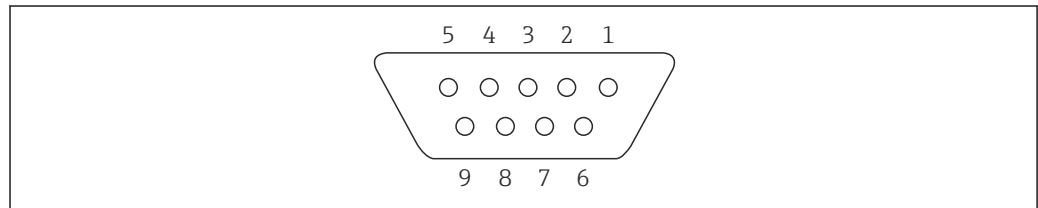

A0058949

Pin	Function
1/6	+48 V supply
2/7	Mark
3/8	Space
5/9	0 V supply
4	Spare

5.6.10 V1 Connection

Connector Type: Phoenix Connector, Screw Terminal

Interface connection:

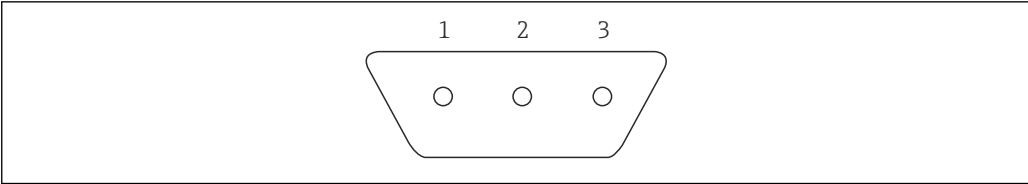

A0058950

Pin	HART
1	Fieldbus 0 V
2	Screen
3	Fieldbus +24 V

6 Communication Lights

6.1 Tankvision Multi Scan Communication Lights

On the rear panel of the Tankvision Multi Scan, on the right-hand side the panel is devoted to LED indicators which show communications activity on the corresponding interfaces. Each port has two LEDs, one labelled **Rx** flashes to indicate incoming signals, the other labelled **Tx** flashes to indicate outgoing signals. Additionally, a power LED indicates whether the device is powered on when the LED is lit.

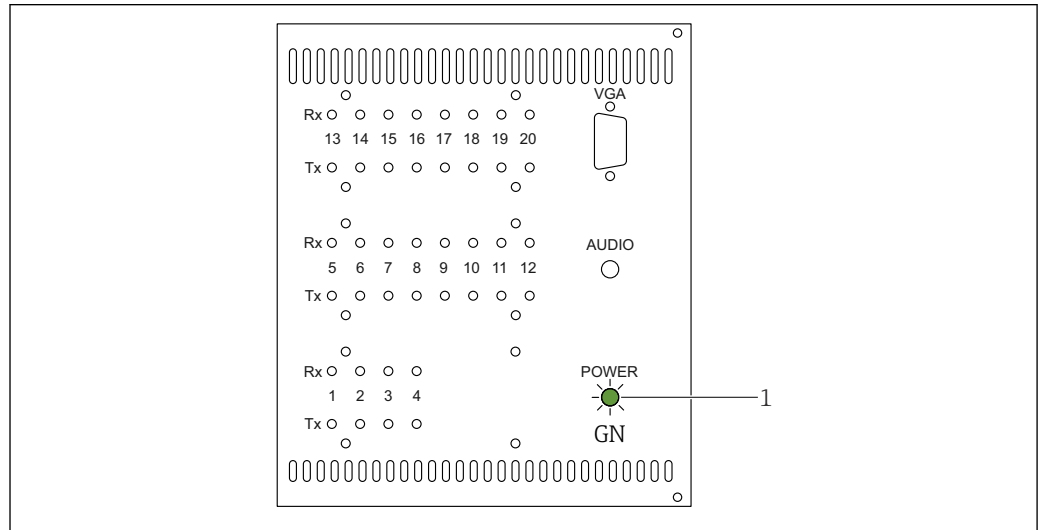

A0058951

1 Power LED, green

6.2 Interpreting Communications Status

The **Rx** and **Tx** indicators can be used to quickly evaluate the status of communications on the port they represent. In most applications the Tankvision Multi Scan behaves as a bus master transmitting requests to field instruments and awaiting a response. Other ports may be configured to output data to remote systems, and respond to requests.

Neither Rx nor Tx light blink

Rx ○ Tx ○	<p>Input Interface The Tankvision Multi Scan is not transmitting requests.</p> <p>Output Interface The Tankvision Multi Scan is not receiving requests from the remote system.</p>
--------------	--



Both Rx and Tx lights are blinking

Rx ● YE Tx ● YE	<p>Input Interface The Tankvision Multi Scan is polling the field and receiving responses from the instruments on the bus.</p> <p>Output Interface The Tankvision Multi Scan is receiving requests and responding to them.</p>
--------------------	--

Only the Tx light is blinking

Rx ○ Tx ● YE	<p>Input Interface The Tankvision Multi Scan is sending requests, but getting no response from the field instruments.</p> <p>Output Interface The Tankvision Multi Scan is transmitting data.</p>
-----------------	---

Only the Rx light is blinking

<div style="border: 1px solid black; padding: 2px; display: inline-block;"> Rx  YE Tx  </div>	<p>Input Interface There is some other device transmitting data on the bus, i.e. acting as a bus master.</p> <p>Output Interface There are messages being received on the bus, but the Tankvision Multi Scan is either ignoring the request or failing to decode the request, and therefore cannot respond.</p>
--	---

6.3 Input communications

When diagnosing communications problems on ports acting as a bus master, polling field devices and instruments, closer monitoring of the LED indications can yield insights into the performance. Most field input protocols by default send a request then wait a maximum of 2 seconds for a response. A typical field instrument will respond within several milliseconds of the request. When the Tankvision Multi Scan gets a valid response, it will immediately stop waiting and send the next request. Consequently, when a port is operating at its optimum efficiency the Rx and Tx LEDs will flicker constantly.

If the LEDs flicker intermittently, pause for 2 seconds and then resume, this is indicative that one or more of the field instruments is not responding.

Some protocols (e.g. RS485) can exhibit a 'local echo' behaviour, where a request is transmitted by the Tankvision Multi Scan and simultaneously received as an echo. If the Rx and Tx lights are blinking in unison the local echo effect may be the cause. The Slo-Mo filming on modern smart phones can be used to distinguish between local echo and a quick response from a field instrument.

Further diagnostic information can be obtained by logging in to the Tankvision Multi Scan user interface and using DCC Host Communication monitor.

6.4 Output interfaces

When a port is acting as a data source to a remote system, the Tankvision Multi Scan is normally inactive unless responding to a request. If there is no activity on the Rx LED, it indicates that the request is not getting to the device. If a fast baud rate is used and the protocol requests are very short, for example Modbus, then it may be difficult to perceive the incoming request. Filming the port lights with a Slo-Mo capable phone can be a useful way to see those incoming requests.

The typical reasons why a Rx signal would not be responded to are: the request address does not match the port configuration, the serial port configuration is incorrect (mismatched baud, parity, stop bits, word size). Having checked the comms further diagnostics can be performed by logging in to the device and examining the output from DCC Slave.



71708418

www.addresses.endress.com
