

Fieldgate FXA 520



- (de)** Sicherheitshinweise für elektrische Betriebsmittel für explosionsgefährdete Bereiche.
- (en)** Safety instructions for electrical apparatus certified for use in explosion-hazardous areas.
- (fr)** Conseils de sécurité pour matériels électriques destinés aux zones explosibles.
- (es)** Instrucciones de seguridad de aparatos eléctricos homologados para su utilización en áreas expuestas a riesgos de deflagración. Si no entiende este manual, puede pedir un ejemplar en su idioma.
- (it)** Istruzioni di sicurezza per apparecchiature elettriche certificate per l'utilizzo in aree con pericolo di esplosione. Se il presente manuale non risulta comprensibile potete ordinarne una copia tradotta nella vostra lingua.
- (nl)** Veiligheidsinstructies voor elektrisch materieel in explosiegevaarlijke omgeving. Wanneer u deze handleiding niet kunt lezen, kunt u een in uw landstaal vertaalde handleiding bij ons bestellen.
- (fi)** Turvallisuusohjeita sähkölaitteille, jotka on vahvistettu käytettäväksi räjähdysvaarallisilla alueilla. Jos et ymmärrä tätä käsikirjaa, voit tilata meiltä käännöksen omalla kansallisella kielelläsi.
- (sv)** Säkerhetsföreskrifter för elektrisk utrustning certifierad för användning i explosionsfarliga områden. Om du inte förstår denna manual, kan en översatt kopia på ditt eget språk beställas från oss.
- (da)** Sikkerhedsforskrifter for elektriske apparater certificeret til brug i explosionsfarlige områder. Hvis du ikke forstår denne manual, kan en oversat kopi af den på dit eget sprog bestilles fra os.
- (pt)** Instruções de segurança para dispositivos eléctricos certificados para utilização em áreas de risco de incêndio. Se não compreender este manual, pode encomendar-nos directamente uma cópia na sua língua.
- (el)** Οδηγίες ασφαλείας για ηλεκτρικές συσκευές που εγκρίνονται για χρήση σε περιοχές με κίνδυνο εκρήξεων. Αν δεν μπορείτε να κατανοήσετε το περιεχόμενο του εγχειριδίου αυτού, μπορείτε να παραγγείλετε από την εταιρεία μας ένα αντίτυπο μεταφρασμένο στη γλώσσα σας.



es Declaración de conformidad

Por la presente declaración y la inclusión de la marca CE, el fabricante Endress+Hauser, Maulburg, Alemania, garantiza que el producto cumple lo estipulado por la Directiva CEM 89/336/CEE y la Directiva 94/9/CE. La prueba de conformidad se presenta según las normas expuestas.

it Dichiarazione di conformità

Con questa dichiarazione e con l'applicazione del marchio CE, il costruttore Endress+Hauser, Maulburg, Germania, assicura che il prodotto è conforme ai regolamenti della direttiva CEM 89/336/CEE e della direttiva 94/9/CE. Prova della conformità è fornita dall'osservanza degli standard elencati.

nl Conformiteitsverklaring

De leverancier Endress+Hauser, Maulburg, Duitsland, waarborgt met deze verklaring en het aanbrengen van de CE-markering dat het product overeenstemt met de voorschriften van de EMC-richtlijn 89/336/EG en de richtlijn 94/9/EG. De overeenstemming wordt door de genoemde normen bewezen.

fi Varmennustodistus

Tällä varmennustodistuksella sekä CE-merkillä, valmistaja Endress+Hauser, Maulburg, Saksa, vakuuttaa, että tuote on direktiivien EMC 89/336/ETY ja 94/9/EUmukainen. Näyttö vastaavuudesta on annettu asiakirjoissa, jotka on listattu varmennustodistukseen.

sv Försäkran om överensstämmelse

Endress+Hauser, Maulburg, Tyskland försäkrar med denna försäkran om överensstämmelse och med CE-märkningen att produkten uppfyller bestämmelserna i EMC-direktivet 89/336/EEG och direktiv 94/9/EG. Överensstämmelsen påvisas genom givna standarder.

da Overensstemmelseserklæring

Med denne overensstemmelseserklæring og tilføjelsen af CE-mærket, sikrer producenten Endress+Hauser, Maulburg, Tyskland, at produktet er i overensstemmelse med bestemmelserne i det EMC-regulativ 89/336/EEC og Direktiv 94/9/EC. Dokumentation for overensstemmelsen gives i de anførte standarder.

pt Declaração de Conformidade

Com esta Declaração de Conformidade e o anexo do CE-Mark, o fabricante Endress+Hauser, Maulburg, Alemanha, garante que o produto obedece aos regulamentos da Directiva EMC 89/336/EEC e Directiva 94/9/EC. A prova da conformidade é apresentada segundo os padrões indicadas.

el Μ' αυτήν την Δήλωση

Συμμόρφωσης και τη συνημμένη σήμανση CE, ο βεβαιώνει η Endress+Hauser, Maulburg, Γερμανία ότι το προϊόν συμμορφώνεται σύμφωνα με τους κανονισμούς της Ευρωπαϊκής Οδηγίας 89/336/ΕΟΚ περί Ηλεκτρομαγνητικής Συμβατότητας και την Οδηγία Προστασίας από Εκρήξεις 94/9/ΕΕ. Το Αποδεικτικό της Συμμόρφωσης δίνεται μέσω των προτύπων που αναφέρονται στη Δήλωση Συμμόρφωσης.

EG 02 037-a

EG-Konformitätserklärung

EC declaration of conformity
Déclaration CE de conformité

Endress+Hauser GmbH+Co. KG, Hauptstraße 1, 79689 Maulburg

erklärt in alleiniger Verantwortung, dass das Produkt

declares in sole responsibility, that the product
déclare sous sa seule responsabilité que le produit

FIELDGATE

FXA 520

mit den Vorschriften folgender Europäischer Richtlinien übereinstimmt:

conforms with the regulations of the following European Directives:
est conforme aux prescriptions et directives Européennes suivantes:

EMV-Richtlinie 89/336/EWG

Ex-Richtlinie 94/9/EG

Angewandte harmonisierte Normen oder normative Dokumente:

Applied harmonised standards or normative documents:
Normes harmonisées ou documents normatifs appliqués:

EN 61326	(2001)	EN 50014 (1997+A1+A2)
EN 61010-1	(1995)	EN 50020 (1994)
		EN 50281-1-1 (1998)
		EN 50284 (1999)
		EN 60950 (1997)

EG-Baumusterprüfbescheinigung Nr.: **DMT 02 ATEX E 099**

EC-Type Examination Certificate No.:

Numéro de l'attestation d'examen CE de type:

Benannte Stelle:

TÜV Hannover/Nr. 0032

Notified body performing the QA surveillance:

Organisme notifié de contrôle du système de qualité:

Erstmalige Anbringung des CE-Zeichens: **02**

CE-mark first affixed:

Année de mise en conformité CE:

Maulburg, 22.07.02

E. V. J. Klotz
Leiter Zertifizierung
Certification Manager
Manager de Certification

Endress+Hauser
The Power of Know How



Fieldgate FXA 520

DMT 02 ATEX E 099

Zugehörige Dokumentation
Betriebsanleitung
BA 258F

Sicherheitshinweise für elektrische Betriebsmittel für explosionsgefährdete Bereiche



Kennzeichnung nach Richtlinie 94/9/EG: CE

II (1) GD

- Gerätegruppe II
- zugehöriges Betriebsmittel im nicht-explosionsgefährdeten Bereich mit externen Stromkreisen zum Anschluß an Geräte der Kategorie 1 G oder 1 D

Zuordnung der Gefahrenzone der Montagestelle zur Kategorie der explosionsgeschützten Geräte bzw. Sensoren:

Geräteklasse	Explosionsfähige Gas-Luft-Gemische (G)	Explosionsfähige Staub-Luft-Gemische (D)
Kategorie 1	Zone 0	Zone 20
Kategorie 2	Zone 1	Zone 21
Kategorie 3	Zone 2	Zone 22

Kennzeichnung der Zündschutzart:

CE

[EEX ia IIC]

- Explosionsgeschütztes elektrisches Betriebsmittel nach Europanorm
- Zündschutzart
- Betriebsmittelgruppe



Endress + Hauser

The Power of Know How





Abb. 1

Sicherheitshinweise für die Installation in explosionsgefährdeten Bereichen:

- 1.) Installieren Sie gemäß den Herstellerangaben und den für Sie gültigen Normen und Regeln.
- 2.) Beachten Sie die Installations- und Sicherheitshinweise der Bedienungsanleitung
- 3.) Betreiben Sie das Gerät nicht außerhalb der elektrischen, thermischen und mechanischen Kenngrößen.
- 4.) Das Fieldgate FXA 520 muß vor Staub und Feuchtigkeit geschützt, z.B. in Meßwarten, oder in einem geeigneten Schutzgehäuse mit mindestens der Schutzart IP55 nach EN 60529 errichtet werden.
- 5.) Das Fieldgate FXA 520 ist ein zugehöriges Betriebsmittel und darf nur außerhalb des explosionsgefährdeten Bereichs verwendet werden.
- 6.) Wenn der eigensichere Stromkreis in staubexplosionsgefährdete Bereiche der Zone 20 bzw. 21 geführt wird, ist sicherzustellen, daß die Geräte, die an diesen Stromkreis angeschlossen werden, die Anforderungen für Kategorie 1D bzw. 2D erfüllen und entsprechend zertifiziert sind.
- 7.) Zwischen eigensicheren und nichteigensicheren Anschlußklemmen muß ein Mindestabstand (Fadenmaß) von 50 mm eingehalten werden.
- 8.) Beachten Sie die Einhaltung der Abstände nach EN 50020 und die für Sie gültigen Normen und Regeln bei Kombination des Fieldgates FXA 520 auf der selben Hutschiene mit anderen Typen und Fabrikaten (Abb. 1).
- 9.) Die eigensicheren Eingangstromkreise des Fieldgates FXA 520 sind bis zu einem Scheitelwert der Nennspannung von 375 V von den übrigen Stromkreisen sicher galvanisch getrennt.
- 10.) Beachten Sie die Regeln der Zusammenschaltung von eigensicheren Stromkreisen nach EN 60079-14 (Nachweis der Eigensicherheit).

Umgebungstemperaturbereich:	0 °C ≤ Tamb ≤ + 60 °C (Einzelmontage) 0 °C ≤ Tamb ≤ + 50 °C (Reihenmontage)
------------------------------------	--

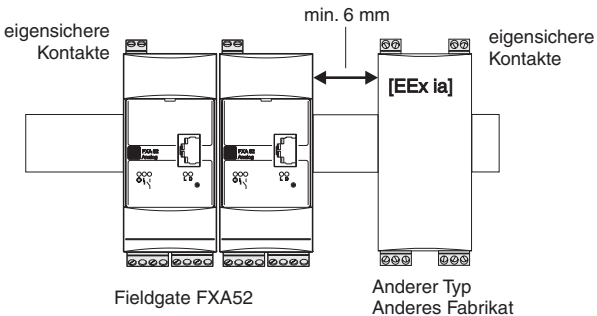
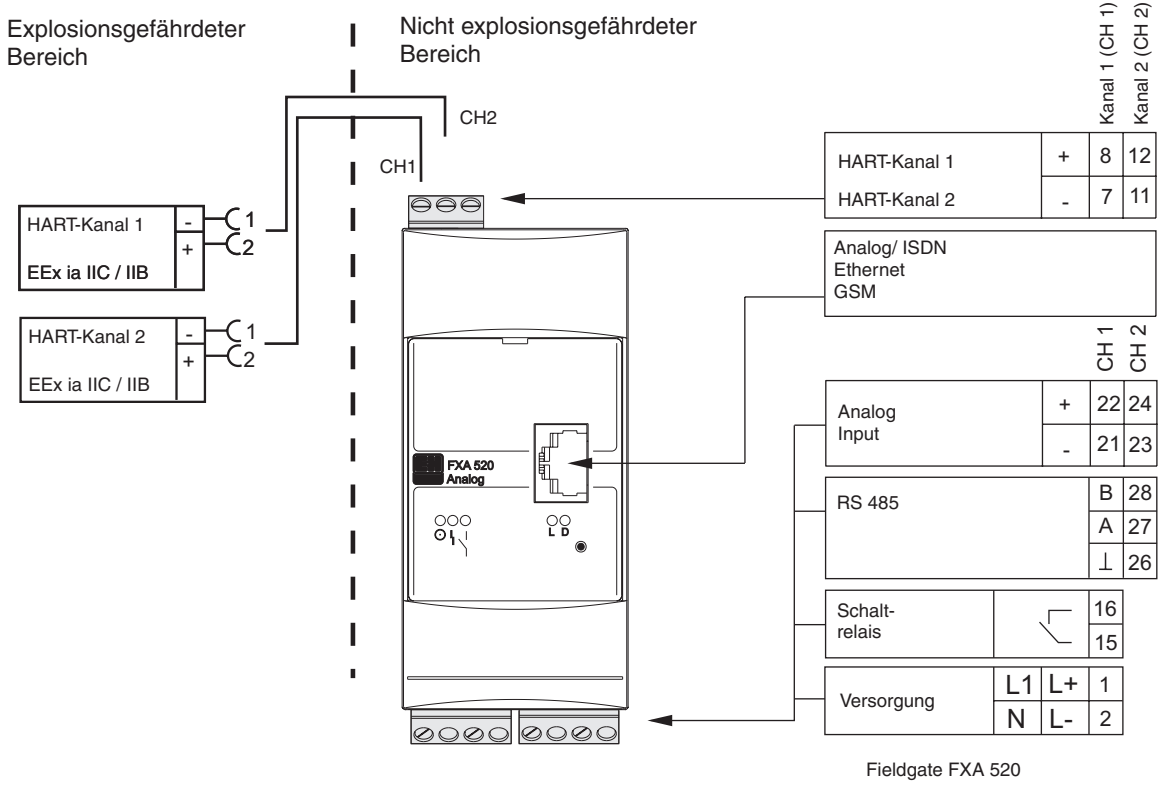
	Wechselstrom-Version:	Gleichstrom-Version:
Versorgungsstromkreis Klemmenanschluss: 1, 2	U = 85 ... 253 V AC 50/60 Hz P ≤ 6,0 VA (Analog Version) P ≤ 4,9 VA (Ethernet Version) P ≤ ... W (GSM Version) P ≤ ... W (ISDN Version)	U = 20 ... 60 V DC U = 20...30 V AC 50/60 Hz P ≤ 2,1 W/ 3,3 VA (Analog Version) P ≤ 1,5 W/ 2,5 VA (Ethernet-Version) P ≤ ... W (GSM-Version) P ≤ ... W (ISDN-Version)
Kontaktstromkreis (Schaltrelais) Klemmenanschluss: 15, 16	U ≤ 253 V AC, I ≤ 2 A, P ≤ 500 VA bei cos φ ≥ 0,7 U ≤ 40 V DC, I ≤ 2 A, P ≤ 80 W	

Sensorstromkreise : Klemmenanschlüsse Kanal 1 (CH 1) : 7, 8, 9 Kanal 2 (CH 2) : 11, 12, 13	Anschlußwerte :		R _i ≥ 273 Ω		
	U _o ≤ 6,5 V				
	I _o ≤ 6,0 mA				
	P _o ≤ 9,8 mW				
	U _i ≤ 30 V				
		[EEx ia] IIC		[EEx ia] IIB	
		L _o	C _o	L _o	C _o
max. externe Kapazität bei max. externer Induktivität		0,5 mH	2000 nF	1 mH	10 µF
		1,0 mH	2000 nF	2 mH	10 µF
max. externe Kapazität oder max. externe Induktivität		5 mH	1500 nF	5 mH	7 µF



Fieldgate FXA 520

DMT 02 ATEX E 099

Associated documentation
Operating Instructions
BA 258F

Safety Instructions for Electrical Apparatus Certified for Use in Explosion-hazardous Areas



Designation according to Directive 94/9/EC: **CE** **Ex**

II (1) GD

- Device group II
- Associated operating equipment in non-hazardous areas with external electric circuit for connection to devices in categories 1 G or 1 D

Allocation of hazardous zones to assembly points for categories of explosion protected devices or sensors:

Equipment category	Explosive gas-air mixture (G)	Explosive dust-air mixture (D)
Category 1	Zone 0	Zone 20
Category 2	Zone 1	Zone 21
Category 3	Zone 2	Zone 22

Explosion protection identification:



[EEX ia IIC]

- Explosion protected electrical apparatus as per European standards
- Explosion protection
- Apparatus group



Endress + Hauser

The Power of Know How



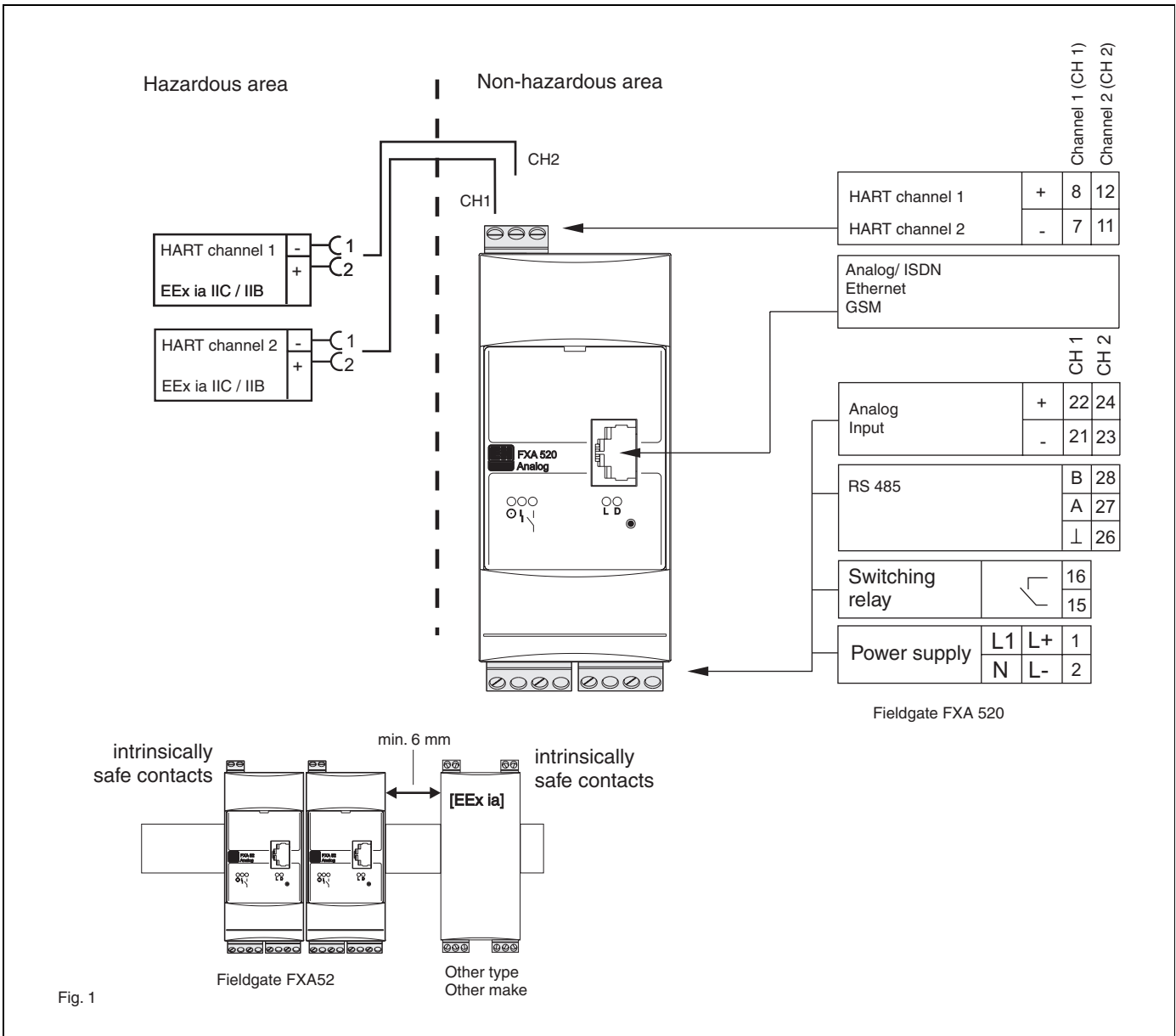

Safety instructions for installation in hazardous areas:

- 1.) Install in accordance with the manufacturer's specifications and the applicable standards and regulations.
- 2.) Observe the installation and safety instructions in the Operating Instructions
- 3.) Do not operate the device outside of the electrical, thermal and mechanical parameters.
- 4.) The Fieldgate FXA 520 must be installed such that it is protected against dust and moisture, e.g. in measuring stations, or in a suitable protective housing with a minimum degree of protection of IP55 as per EN 60529.
- 5.) The Fieldgate FXA 520 is associated apparatus and must only be used outside of hazardous areas.
- 6.) When the intrinsically safe electric circuit runs through dust incensive hazard areas in zones 20 or 21, ensure that the devices that are connected to this electric circuit meet the requirements for category 1D or 2D and are certified accordingly.
- 7.) A minimum distance (tight string length) of 50 mm must be kept between intrinsically safe and non-intrinsically safe terminals.
- 8.) Ensure that the distances are kept in accordance with EN 50020 and observe the applicable standards and regulations when combining the Fieldgate FXA 520 with other types and makes on the same top-hat rail (Fig. 1).
- 9.) The Fieldgate FXA 520's intrinsically safe input circuits are safely galvanically isolated from the remaining electric circuits up to a nominal voltage peak value of 375 V.
- 10.) Observe the directives on interconnecting intrinsically safe electric circuits in accordance with EN 60079-14 (proof of intrinsic safety).

Ambient temperature range:	0 °C ≤ Tamb ≤ + 60 °C (individual mounting) 0 °C ≤ Tamb ≤ + 50 °C (series mounting)
-----------------------------------	--

	Alternating current version:	Direct current version:
Power supply circuit Terminal connection: 1, 2	U = 85 ... 253 V AC 50/60 Hz P ≤ 6.0 VA (Analog version) P ≤ 4.9 VA (Ethernet version) P ≤ __ W (GSM version) P ≤ __ W (ISDN version)	U = 20 ... 60 V DC U = 20...30 V AC 50/60 Hz P ≤ 2.1 W/ 3.3 VA (Analog version) P ≤ 1.5 W/ 2.5 VA (Ethernet version) P ≤ __ W (GSM version) P ≤ __ W (ISDN version)
Contact circuit (switching relay) Terminal connection: 15, 16	U ≤ 253 V AC, I ≤ 2 A, P ≤ 500 VA at cos φ ≥ 0.7 U ≤ 40 V DC, I ≤ 2 A, P ≤ 80 W	

Sensor circuits : Terminal connections Channel 1 (CH 1) : 7, 8, 9 Channel 2 (CH 2) : 11, 12, 13	Connection values :		$R_i \geq 273 \Omega$	
	$U_o \leq 6.5 \text{ V}$ $I_o \leq 6.0 \text{ mA}$ $P_o \leq 9.8 \text{ mW}$ $U_i \leq 30 \text{ V}$			
	[EEx ia] IIC		[EEx ia] IIB	
	L_o	C_o	L_o	C_o
Max. external capacity at max. external inductivity	0.5 mH	2000 nF	1 mH	10 μF
	1.0 mH	2000 nF	2 mH	10 μF
Max. external capacity or max. external inductivity	5 mH	1500 nF	5 mH	7 μF



Mise en service
XA 188F-A
52013636

Fieldgate FXA 520

DMT 02 ATEX E 099

Documentation correspondante
Mise en service
BA 258F

Conseils de sécurité pour matériels électriques destinés aux zones explosibles



Marquage selon directive 94/9/CE :



II (1) GD

- Groupe d'appareils II
- Matériel électrique associé en zone non explosible avec circuits de courant externes pour le raccordement à des appareils de la catégorie 1 G ou 1 D

Affectation de la zone dangereuse du point de montage à la catégorie des appareils ou capteurs avec protection anti-déflagrante :

Catégorie d'appareils	Mélanges explosifs gaz - air (G)	Mélanges explosifs poussières - air (D)
Catégorie 1	zone 0	zone 20
Catégorie 2	zone 1	zone 21
Catégorie 3	Zone 2	zone 22

Marquage du mode de protection :



[EEX ia IIC]

- Matériel électrique protégé contre les explosions selon norme européenne
- Mode de protection
- Groupe d'appareils



Endress + Hauser

The Power of Know How



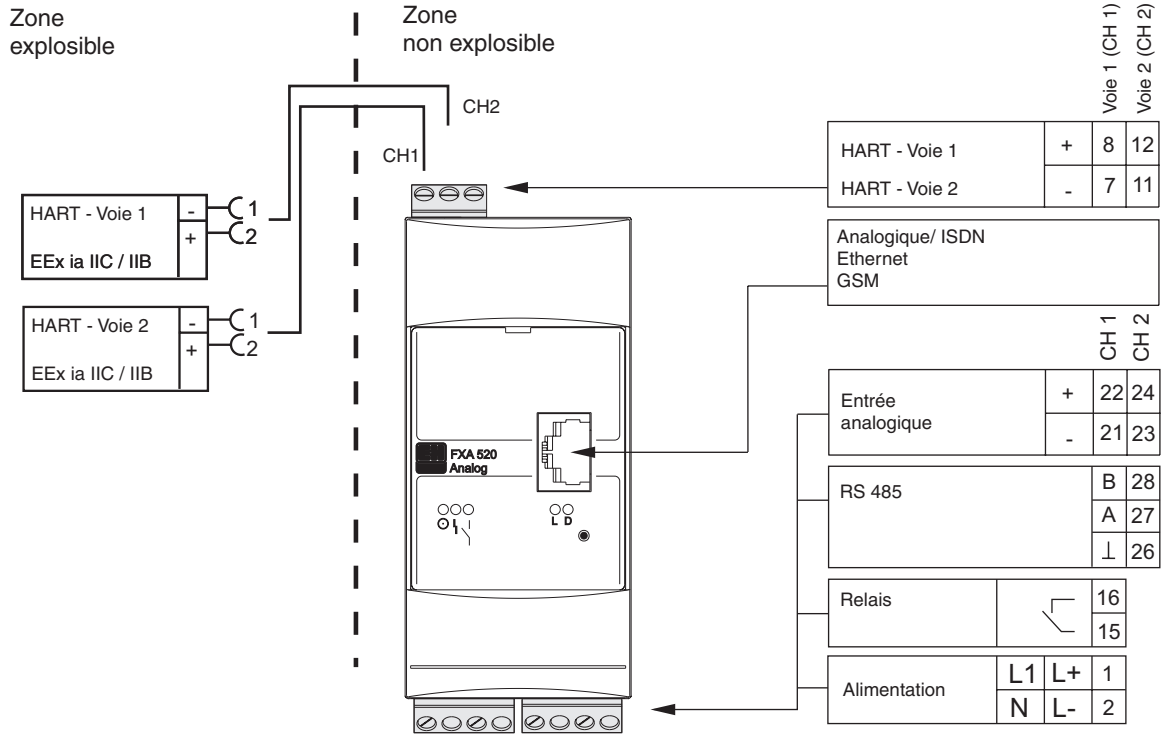

Fieldgate FXA 520

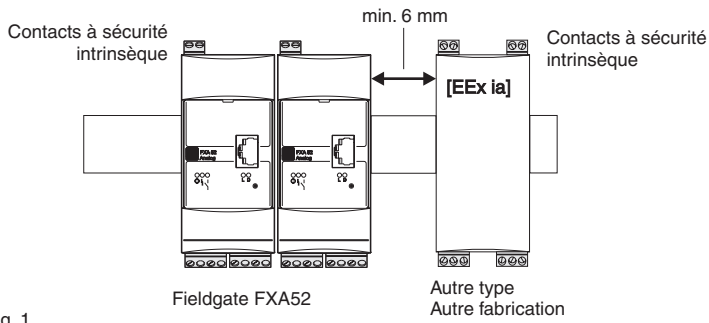

Fig. 1

Conseils de sécurité pour l'installation en zones explosibles :

- 1.) Installer d'après les instructions du fabricant et les normes et règles en vigueur.
- 2.) Tenir compte des conseils d'installation et de sécurité du manuel de mise en service.
- 3.) Ne pas utiliser l'appareil en dehors des limites nominales électriques, thermiques ou mécaniques.
- 4.) Le Fieldgate FXA 520 doit être protégé contre la poussière et l'humidité, par ex. en étant monté dans des salles de contrôle ou dans un boîtier approprié ayant au minimum la protection IP55 selon EN 60529.
- 5.) Le Fieldgate FXA 520 est un matériel électrique associé et ne doit être utilisé qu'en dehors de la zone explosible.
- 6.) Si le circuit à sécurité intrinsèque est mené dans les zones à poussières explosives, zone 20 ou 21, il faut s'assurer que les appareils raccordés à ce circuit remplissent les exigences de la catégorie 1D ou 2D et qu'ils possèdent les certificats requis.
- 7.) Entre les bornes de raccordement à sécurité intrinsèque et celles sans, respecter un écart minimal (chemin de fuite) de 50 mm.
- 8.) Respecter les écarts selon EN 50020 ainsi que les normes et règles en vigueur lors de la combinaison du Fieldgate FXA 520 sur le même rail profilé avec des appareils d'autres types et fabrications (fig. 1).
- 9.) Les circuits à sécurité intrinsèque du Fieldgate FXA 520 sont séparés galvaniquement de manière sûre de tous les autres circuits jusqu'à une valeur de crête de la tension nominale de 375 V.
- 10.) Respecter les règles en matière d'interconnexion de circuits à sécurité intrinsèque selon EN 60079-14 (preuve de la sécurité intrinsèque).

Gamme de température ambiante :	0 °C ≤ Tamb ≤ + 60 °C (montage isolé) 0 °C ≤ Tamb ≤ + 50 °C (montage accolé)
--	---

	Version courant alternatif :	Version courant continu :
Circuit d'alimentation Raccordement par bornes : 1, 2	U = 85 ... 253 V AC 50/60 Hz P ≤ 6,0 VA (version analogique) P ≤ 4,9 VA (version Ethernet) P ≤ __ W (version GSM) P ≤ __ W (version ISDN)	U = 20 ... 60 V DC U = 20...30 V AC 50/60 Hz P ≤ 2,1 W/ 3,3 VA (version analogique) P ≤ 1,5 W/ 2,5 VA (version Ethernet) P ≤ __ W (version GSM) P ≤ __ W (version ISDN)
Circuit de contact (Relais) Raccordement par bornes : 15, 16	U ≤ 253 V AC, I ≤ 2 A, P ≤ 500 VA pour cos φ ≥ 0,7 U ≤ 40 V DC, I ≤ 2 A, P ≤ 80 W	

Circuits de capteurs : Raccordements par bornes Voie 1 (CH 1) : 7, 8, 9 Voie 2 (CH 2) : 11, 12, 13	Valeurs de raccordement :		R _i ≥ 273 Ω	
			[EEx ia] IIC	
	L _o	C _o	L _o	C _o
Capacité max. externe pour inductance max. externe	0,5 mH	2000 nF	1 mH	10 μF
	1,0 mH	2000 nF	2 mH	10 μF
Capacité max. externe ou inductance max. externe	5 mH	1500 nF	5 mH	7 μF

