



Level



Pressure



Flow



Temperature



Liquid
Analysis



Registration



Systems
Components



Services



Solutions

Operating Instructions

Topcal S CPC310

Automation of pH/Redox Measurements

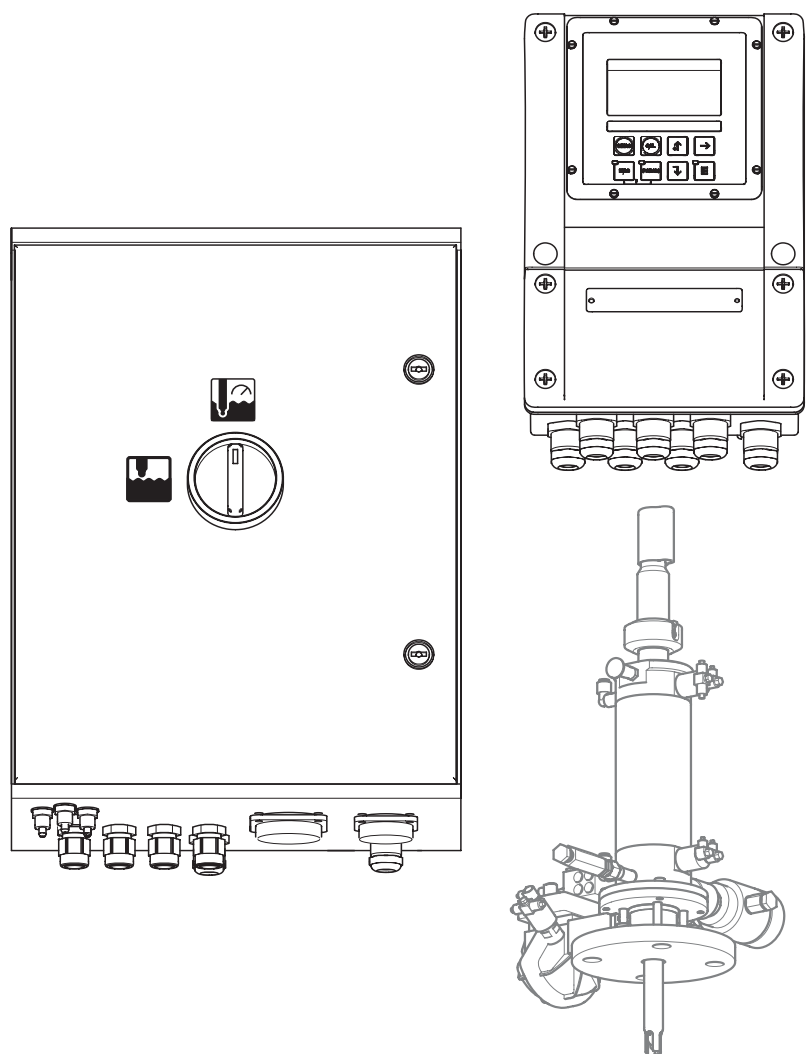

Brief overview

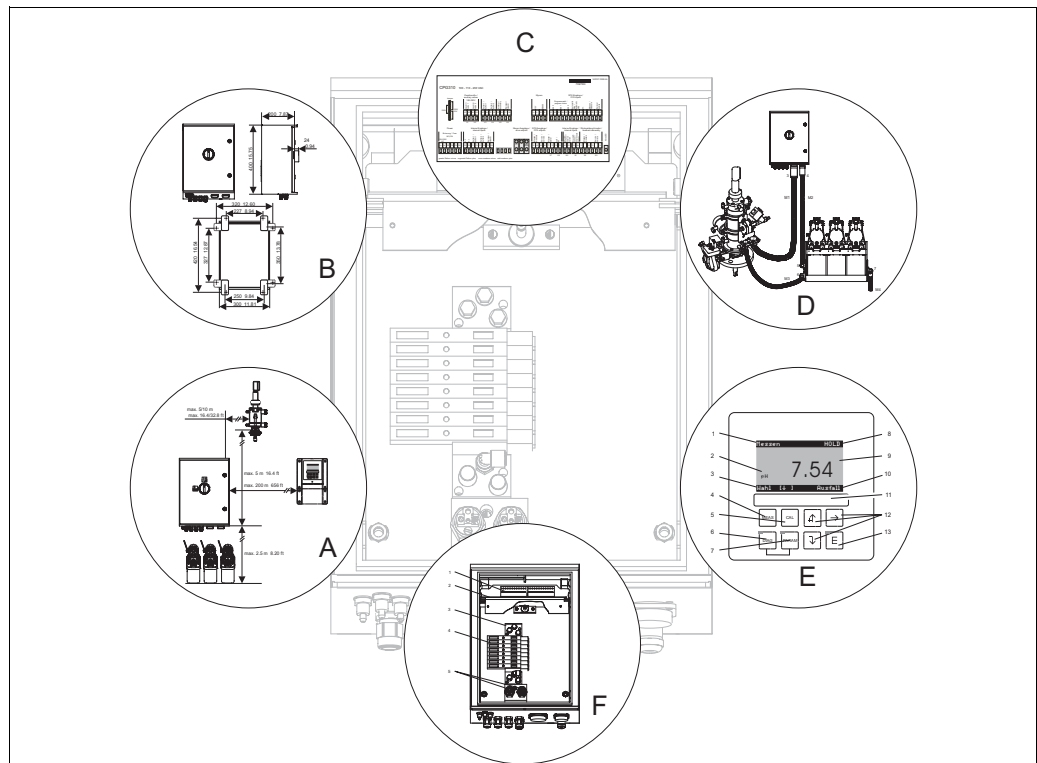

a0005033

→ 10	A	Installation instructions: Types of mounting, maximum spacing, assembly installation
▼		
→ 13	B	Dimensions and installation
▼		
→ 19	C	Electrical connection of mandatory and optional system components
▼		
→ 38	D	Pneumatic system connection
▼		
→ 49 → 53 → 59 → 108	E	Operation Commissioning Configuration Calibration
▼		
→ 127 → 136	F	Troubleshooting Spare parts

Table of contents

1	Safety instructions	5			
1.1	Designated use	5			
1.2	Installation, commissioning and operation	5			
1.3	Operational safety	5			
1.4	Return	6			
1.5	Notes on safety conventions and icons	6			
2	Identification	7			
2.1	Device designation	7			
2.1.1	Nameplate	7			
2.1.2	Scope of delivery	7			
2.1.3	Product structure	8			
2.2	Certificates and approvals	9			
3	Installation	10			
3.1	Incoming acceptance, transport, storage	10			
3.2	Installation conditions	10			
3.2.1	Types of mounting	10			
3.2.2	Spacing	11			
3.2.3	Assembly installation	11			
3.2.4	Dimensions	12			
3.3	Installation instructions	13			
3.3.1	Securing rinsing block to assembly	13			
3.3.2	Installation instructions	13			
3.3.3	Wall mounting	14			
3.3.4	Post mounting and panel mounting	15			
3.4	Post-installation check	17			
4	Wiring	18			
4.1	Electrical connection	19			
4.1.1	Overview	19			
4.1.2	Connection compartment sticker for CPG310 control unit	20			
4.1.3	Connection compartment sticker, Mycom S CPM153	21			
4.1.4	Power supply and communication connection between transmitter and control unit	22			
4.1.5	Level probes for buffer and cleaner	23			
4.1.6	Analog sensors	24			
4.1.7	Digital sensors with Memosens technology	29			
4.1.8	Current outputs	30			
4.1.9	Mycom relay	31			
4.1.10	External inputs (PLC to CPG310) and outputs (CPG310 to PLC)	32			
4.1.11	External inputs (PLC to Mycom)	34			
4.1.12	Inductive limit position switch	35			
4.2	Post-connection check	37			
5	Medium connection	38			
5.1	Compressed air pipe and additional valves	38			
5.2	Water pipe and rinse chamber	39			
5.3	Multihoses	40			
5.3.1	Connecting multihoses	41			
5.4	Assemblies	42			
5.4.1	Cleanfit CPA471/472/475	42			
5.4.2	Cleanfit CPA473/474	44			
5.5	Pumps	46			
5.5.1	Compressed air control	46			
5.5.2	Buffer and cleaner	47			
5.5.3	Venting	48			
5.6	Post-connection check	48			
6	Operation	49			
6.1	Display and operating elements	49			
6.1.1	Display	49			
6.1.2	Function of keys	49			
6.1.3	Service switch	50			
6.1.4	Measured value display	51			
6.1.5	Operation access authorization	51			
6.1.6	Menu editor types	52			
7	Commissioning	53			
7.1	Points to note when commissioning digital sensors	53			
7.2	Points to note when commissioning ISFET sensors	53			
7.3	Function check	53			
7.4	Switching on	54			
7.5	Quick Setup	54			
7.5.1	Configuring Clean program	57			
7.6	Device configuration	59			
7.6.1	Set up 1 - Sensor input	59			
7.6.2	Set up 1 - Display	60			
7.6.3	Set up 1 - Access codes	60			
7.6.4	Set up 1 - Current outputs	61			
7.6.5	Set up 1 - Relays	63			
7.6.6	Set up 1 - Temperature	64			
7.6.7	Set up 1 - Alarm	66			
7.6.8	Set up 1 - Hold	67			
7.6.9	Set up 1 - Calibration	69			
7.6.10	Set up 1 - Topcal validation function	74			
7.6.11	Set up 2 - Data log	74			
7.6.12	Set up 2 - Check	75			
7.6.13	Set up 2 - Controller configuration	77			
7.6.14	Set up 2 - Limit switch	83			
7.6.15	Set up 2 - Controller quick adjustment	85			
7.6.16	Set up 2 - Topcal	85			
7.6.17	Set up 2 - Chemoclean	95			
7.6.18	Manual operation	99			
7.7	Diagnosis	101			
7.8	Calibration	108			
7.8.1	Calibration pH	109			
7.8.2	Calibration redox	111			

8 Maintenance 115

8.1	Maintenance of the overall measuring point	115
8.1.1	Cleaning the transmitter	115
8.1.2	Cleaning the sensors	116
8.1.3	Maintenance of digital sensors	117
8.1.4	Liquid KCl supply	117
8.1.5	Manual calibration	117
8.1.6	Assembly	118
8.1.7	Cables, connections and power supply lines	118
8.1.8	Control unit	119

9 Accessories 120

9.1	Sensors	120
9.2	Connection accessories	120
9.3	Mounting accessories	121
9.4	Assemblies	122
9.5	Offline configuration	123
9.6	Housing CYC310	123
9.6.1	Product structure	125
9.7	Operating panel for CPC310	125

10 Troubleshooting 127

10.1	Troubleshooting instructions	127
10.2	System error messages	127
10.3	Process-specific errors	131
10.4	Device-specific errors	134
10.5	Response of outputs to errors	135
10.5.1	Current output behavior	135
10.5.2	Response of contacts to errors	135
10.5.3	Response of contacts to power failure	135
10.5.4	Assembly behavior	136
10.6	Spare parts	136
10.6.1	Device view Mycom S	137
10.6.2	Spare parts list Mycom S	137
10.6.3	Control unit device view	138
10.6.4	Control unit spare parts list	138
10.6.5	View of canister with membrane pump and level sensor	139
10.6.6	Spare parts list for canister with membrane pump and level sensor	139
10.6.7	Pneumatic and hydraulic control unit	140
10.6.8	Rinsing block	141
10.7	Replacing the device fuse	142
10.8	Return	143
10.9	Disposal	143

11 Technical data 144

11.1	Input	144
11.2	Output	144
11.3	Power supply	145
11.4	Performance characteristics	145
11.5	Environment	146
11.6	Process	146
11.7	Mechanical construction	146

12 Appendix 147

12.1	Operating matrix	147
12.2	Connection examples	160
12.3	Wiring example for external program start	161
12.4	Buffer tables	162

Index 163

1 Safety instructions

1.1 Designated use

Topcal S CPC310 is a fully automated measuring, cleaning and calibration system for pH and redox measurement.

The system is fully equipped with power supply cables and hose systems.

The system is particularly suitable for use in the following areas:

- Chemical process systems
- Pharmaceuticals
- Foodstuff industry
- Water treatment and monitoring
- Wastewater treatment
- Sewage treatment plants
- Chemical pulp and paper industry

Topcal S CPC310 is suitable for use in hazardous atmospheres.

Any use other than that described here compromises the safety of persons and the entire measuring system and is, therefore, not permitted.

The manufacturer accepts no liability for damage resulting from incorrect use or use other than that designated.

1.2 Installation, commissioning and operation

Note the following points:

- Installation, commissioning, operation and maintenance of the measuring system must be carried out exclusively by specially trained technical personnel.
The personnel must be authorized to perform such work by the system operator.
- The electrical connection may only be established by an electrical technician.
- Technical personnel must have read and understood these Operating Instructions and must adhere to them.
- Before commissioning the entire measuring point, check all the connections for correctness. Ensure that electrical cables and hose connections are not damaged.
- Do not commission damaged products. Protect them against inadvertent commissioning. Mark the damaged product as defective.
- Faults at the measuring point may only be rectified by authorized and specially trained personnel.
- If faults cannot be rectified, you must take the products out of operation and protect them against inadvertent commissioning.
- Repairs not described in these Operating Instructions may only be carried out directly at the manufacturer's or by the service organization.

1.3 Operational safety

The system is designed to meet state-of-the-art safety requirements, has been tested and left the factory in a condition in which it is safe to operate. The applicable regulations and European standards have been taken into consideration.

As the user, you are responsible for ensuring the following safety regulations are observed:

- Installation regulations
- Local standards and regulations

Electromagnetic compatibility

With regard to electromagnetic compatibility, this device has been tested in accordance with the applicable European standards for industry.

The electromagnetic compatibility indicated only applies to a device that is connected in accordance with the instructions in these Operating Instructions.

1.4 Return

If the device has to be repaired, please return it *cleaned* to your sales center.
For returns please use the original packaging.

1.5 Notes on safety conventions and icons

Warnings



Warning!

This symbol alerts you to hazards which could cause serious injuries, as well as damage to the instrument, if ignored.



Caution!

This symbol alerts you to possible faults which could arise from incorrect operation. They could cause damage to the instrument if ignored.



Note!

This symbol indicates important items of information.

Electrical symbols



Direct current

A terminal at which DC voltage is applied or through which DC flows.



Alternating current

A terminal at which (sine-form) alternating voltage is applied or through which AC flows.



Direct or alternating current

A terminal at which direct or alternating voltage is applied or through which AC flows.



Ground connection

A terminal which, from the user's point of view, is already grounded using a grounding system.



Protective earth terminal

A terminal which must be grounded before other connections may be established.



Alarm relay



Input



Output



DC voltage source



Temperature sensor

2 Identification

2.1 Device designation

2.1.1 Nameplate

The transmitter and the control unit each has its own nameplate.



Made in Germany, D-70839 Gerlingen		Endress+Hauser 	
MYCOM S pH / Redox			
Order code	CPM153-A2A18A010		
Serial no.	3C000505G08		
Meas. range:	-2 ... +16 pH	-1500 mV ... +1500 mV	IP65
Temperature:	-50 ... +150 °C		
Channels:	1		
Output 1:	0/4 ... 20 mA		
Output 2:	0/4 ... 20 mA		
Mains:	24 V AC/DC	50/60 Hz	10 VA
			-10 < Ta < +55 °C
			

Fig. 1: CPM153 nameplate (example)



Made in Germany, D-70839 Gerlingen		Endress+Hauser 	
CPG310			
Order code	CPG310		
Serial no.	3C000505G09		
			IP54
Mains:	230 VAC	50/60 Hz	12 VA
			0 < Ta < +55 °C
			

Fig. 2: CPG310 nameplate (example)

2.1.2 Scope of delivery

The scope of delivery of the system comprises:

- 1 Mycom S CPM153 transmitter
- 1 CPG310 control unit
- 1 rinsing block with securing clamps for assembly
- 4 multihoses
- 2 technical buffer solutions pH 4.00 and 7.00
- 3 double-membrane pumps for conveying cleaner and buffer with canisters
- 1 communication/power supply cable CPG310 / Mycom S CPM153
- 3 level probes, complete with CPG310 cable to canisters
- 1 pressure reduction valve with pressure gauge
- 1 water filter
- 1 device identification card
- 1 set of Operating Instructions in English
- Accessories where applicable

If you have any questions, please contact your supplier or sales center.

2.1.3 Product structure

Approval	
A	Basic features: Non-Ex
G	With ATEX approval, ATEX II (1) 2G EEx, em ib[ia] IIC T4
O	With FM approval Cl. I, Div. 2, with NI input and output circuits, sensor IS Cl. I, Div. 1
P	With FM approval Cl. I, Div. 2, with NI input and output circuits
S	With CSA approval, Cl. I, Div. 2, sensor IS Cl. I, Div. 1
Material of rinsing block, O-ring, connection	
00	PVDF, Viton, G ¼ male
01	PVDF, Viton, NPT ¼" male
02	PVDF, Kalrez, G ¼ male
03	PVDF, Kalrez, NPT ¼" male
10	Stainless steel 1.4404 (AISI 316L), Viton, G ¼ male
11	Stainless steel 1.4404 (AISI 316L), Viton, NPT ¼" male
12	Stainless steel 1.4404 (AISI 316L), Kalrez, G ¼ male
13	Stainless steel 1.4404 (AISI 316L), Kalrez, NPT ¼" male
Sensor input Mycom S	
1	1 measuring circuit for glass electrodes, pH/redox and temperature
2	1 measuring circuit for glass electrodes/ISFET sensors, pH/redox and temperature
5	1 measuring circuit for digital Memosens sensors, pH/redox and temperature
Measurement output Mycom S	
A	2 current outputs 0/4 ... 20 mA, passive (Ex and non-Ex)
B	2 current outputs 0/4 ... 20 mA, active (non-Ex)
C	HART with 2 current outputs 0/4 ... 20 mA, passive
D	HART with 2 current outputs 0/4 ... 20 mA, active
E	PROFIBUS PA, without current outputs
Power supply	
0	... 230 V AC
1	110 ... 115 V AC
8	24 V AC / DC
Language	
A	English / German
B	English / French
C	English / Italian
D	English / Spanish
E	English / Dutch
Cable entry	
0	Cable glands M20 x 1.5
1	Adapter for cable glands NPT ½"
3	Cable gland M20 x 1.5, PROFIBUS-PA-M12 connector
4	Cable gland NPT ½", PROFIBUS-PA-M12 connector
Length of multihose	
0	5 m
1	5 m with electric heating
2	10 m
3	10 m with electric heating
Additional equipment	
0	Basic version
1	Preparation for CYC310 housing
Setting	
A	Factory setting
B	IQ/OQ template German
C	IQ/OQ template English
D	Standard FAT German
E	Standard FAT English
CPC310-	Complete order code

2.2 Certificates and approvals

Declaration of conformity

The product meets the statutory requirements of the harmonized European standards. The manufacturer certifies compliance with the standards by using the **CE** mark.

3 Installation

3.1 Incoming acceptance, transport, storage

- Make sure the packaging is undamaged!
Inform the supplier about damage to the packaging.
Keep the damaged packaging until the matter has been settled.
- Make sure the contents are undamaged!
Inform the supplier about damage to the delivery contents.
Keep the damaged goods until the matter has been settled.
- Check that the scope of delivery is complete and matches your order and the shipping documents.
- For storage and transport purposes, pack the instrument so that it is protected against impacts and humidity. The original packaging offers the best protection. Furthermore, the permitted ambient conditions must be observed (see "Technical data").
- If you have any questions, please contact your supplier or sales center.

3.2 Installation conditions

3.2.1 Types of mounting

You can choose from the following types of mounting for the individual components:

Device	Wall mounting	Post/pipe mounting	Panel mounting
CPG310 control unit	Mounting set included in the scope of delivery.	not applicable	not applicable
Mycom S CPM153, protected	Required: 2 screws Ø 6 mm (0.24") 2 wall plugs Ø 8 mm (0.31")	Mounting set included in the scope of delivery.	Mounting set included in the scope of delivery.
Mycom S CPM153, outdoors	Weather protection cover CYY102-A required if directly exposed to weather conditions (see Accessories).	Weather protection cover CYY102-A and 2x round post fixtures required (see Accessories).	not usual

3.2.2 Spacing

The graphic below illustrates the maximum distances between the system components.

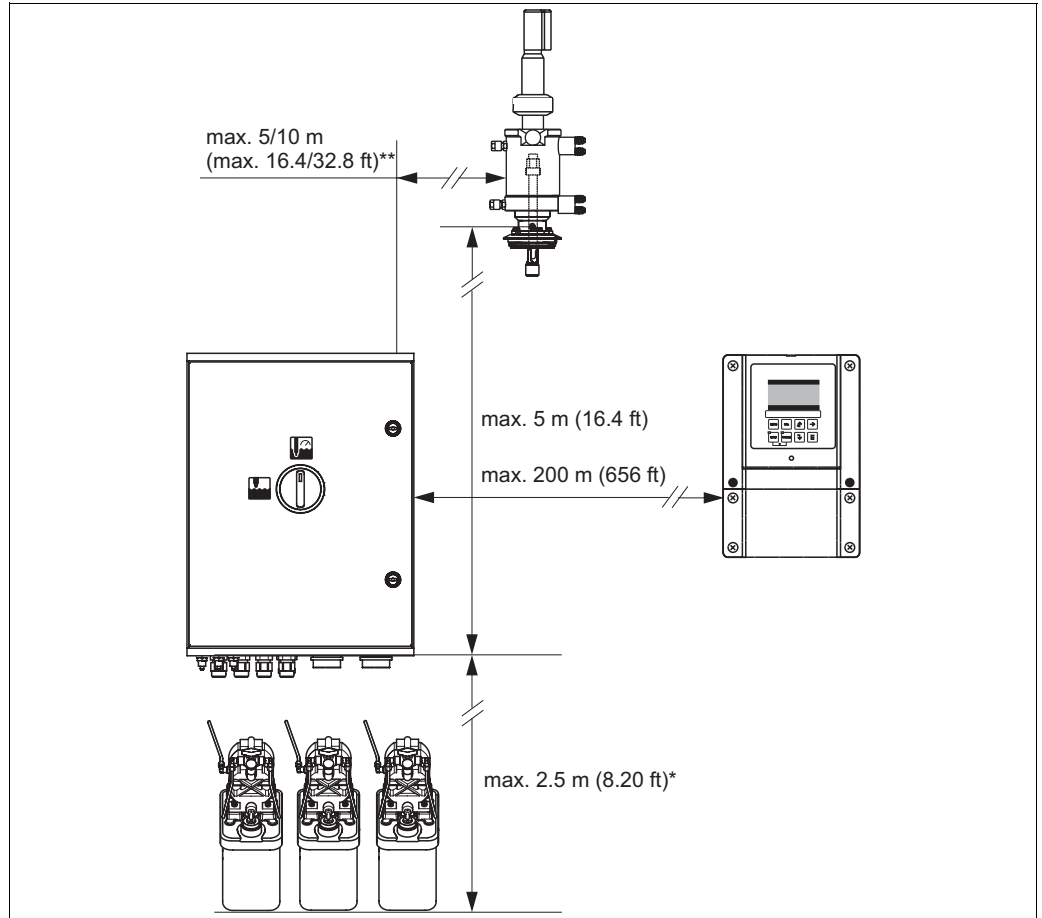

Fig. 3: Maximum spacing for Topcal S CPC310 system components

* When using the multihoses supplied as standard

** Depending on the multihose version ordered

3.2.3 Assembly installation

- A Glass electrode: Installation angle of at least 15 ° to the horizontal.
- B ISFET sensor Tophit: No restrictions, 0 ... 180° recommended

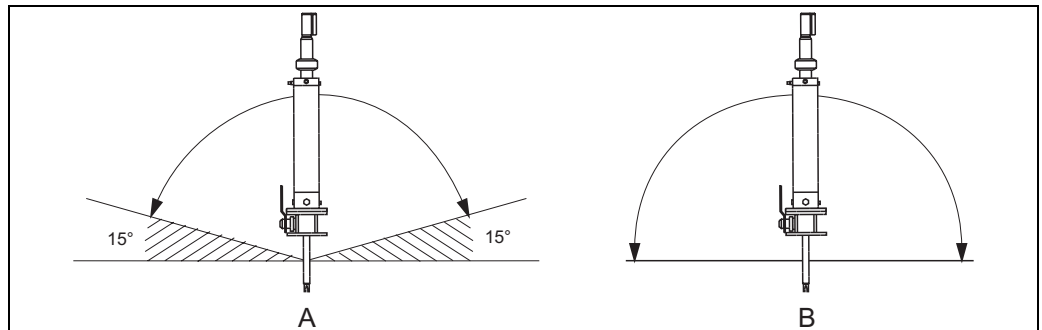

Fig. 4: Permitted orientation depending on the sensor used

3.2.4 Dimensions

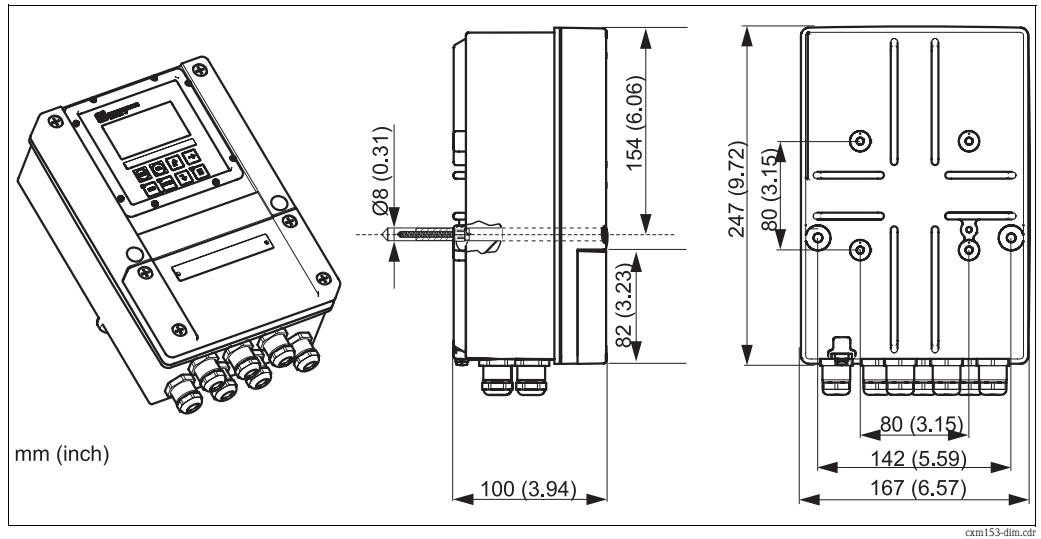

Fig. 5: Dimensions of Mycom S

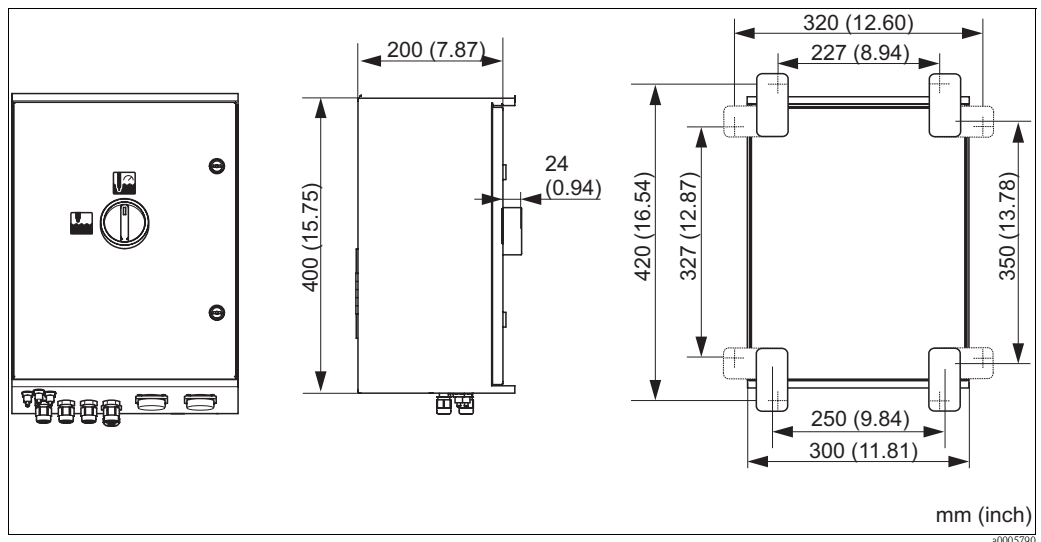

Fig. 6: Dimensions of CPG310 control unit

3.3 Installation instructions

3.3.1 Securing rinsing block to assembly

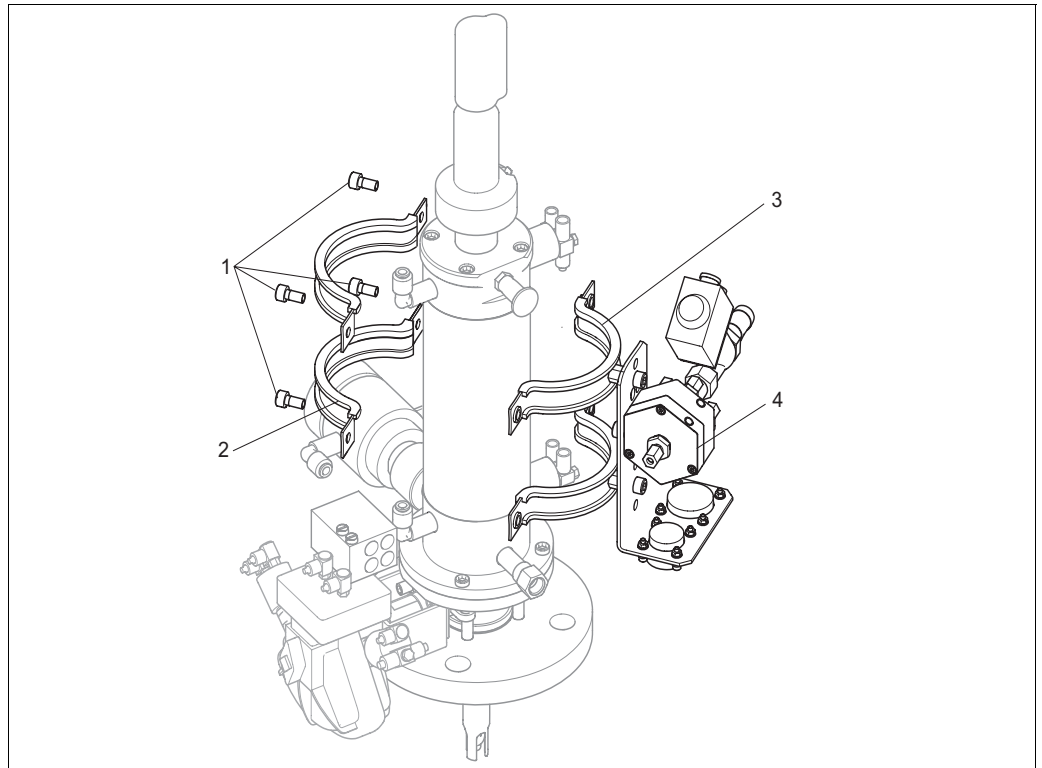

Fig. 7: Mounting the rinsing block on the assembly (example CPA473)

Proceed as follows to mount the rinsing block:

1. Fit the securing clamps with the rinsing block (3 and 4) on the assembly cylinder.
2. Fit the counterclamps (2) on the assembly cylinder from the other side.
3. Connect the clamps with the screws (1) supplied.

3.3.2 Installation instructions

- The Mycom S transmitter is used as a field device as standard. It can also be installed as a panel-mounted instrument.
- Mycom S is suitable for wall mounting with securing screws and for post mounting to cylindrical pipes.
- Always install the transmitter horizontally in such a way that the cable entries are always pointing downwards.

3.3.3 Wall mounting



Caution!

- Make sure the maximum permitted ambient temperature range of -20 ... +60 °C (-4 ... 140 °F) is observed. Avoid direct sunlight.
- Always mount the wall-mount housing in such a way that the cable entries point downwards.

Control unit

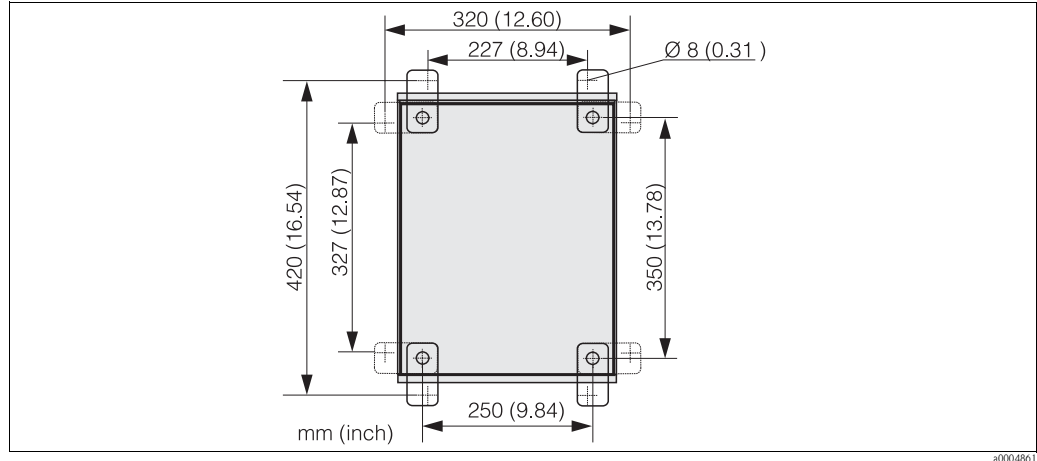

Fig. 8: Dimensions for wall mounting with wall securing kit (part of scope of delivery)

Proceed as follows to wall-mount the unit:

1. Please note that the maximum suction height for buffer and cleaner is 2.5 m (8.2 ft.) when using the standard multihoses supplied. Bore the holes as per the graphic above.
2. Screw the elements of the wall securing set supplied to the rear wall of the housing.
3. Secure the housing to the wall without any inclination.

Transmitter

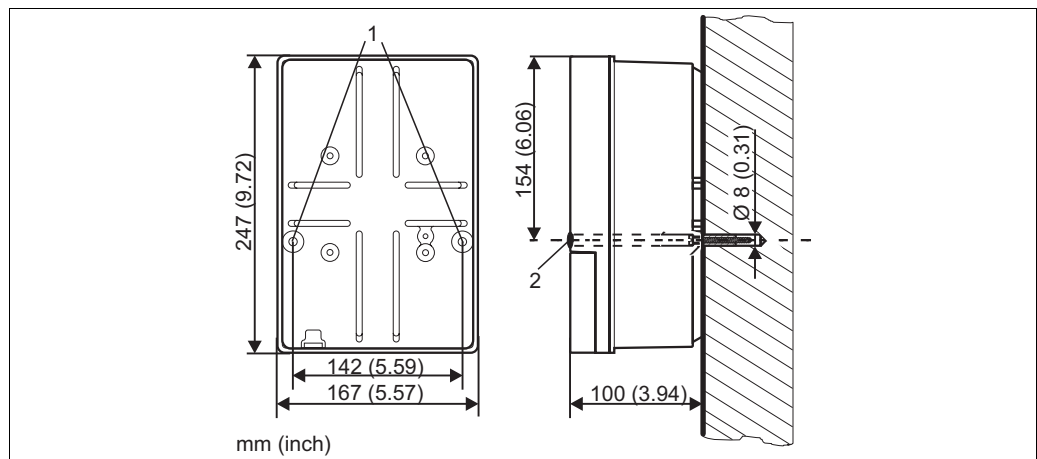

Fig. 9: Dimensions for wall mounting, securing screw: Ø 6 mm (0.24"), wall plug: Ø 8 mm (0.31")

- 1 Securing bores
- 2 Plastic caps

Proceed as follows to wall-mount the unit:

1. Bore the holes as per Fig. 9.
2. Push the two securing screws from the front through the securing bores (item 1).
3. Mount the transmitter housing to the wall as illustrated.
4. Cover the bores with the plastic caps (item 2).

3.3.4 Post mounting and panel mounting



Note!

You need a special mounting kit to secure the transmitter to horizontal and vertical posts or pipes (max. \varnothing 70 mm (2.76")) and for panel mounting.

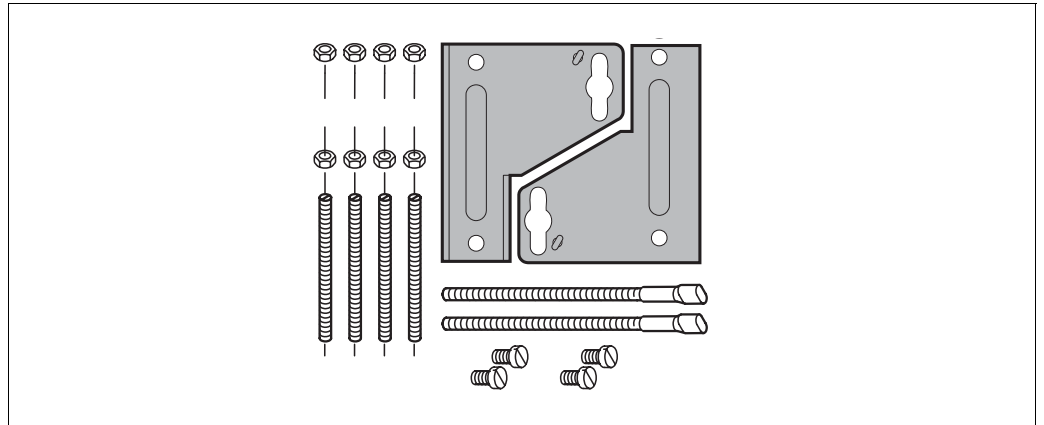

Fig. 10: Mounting kit

Panel mounting

Proceed as follows to panel-mount the transmitter:

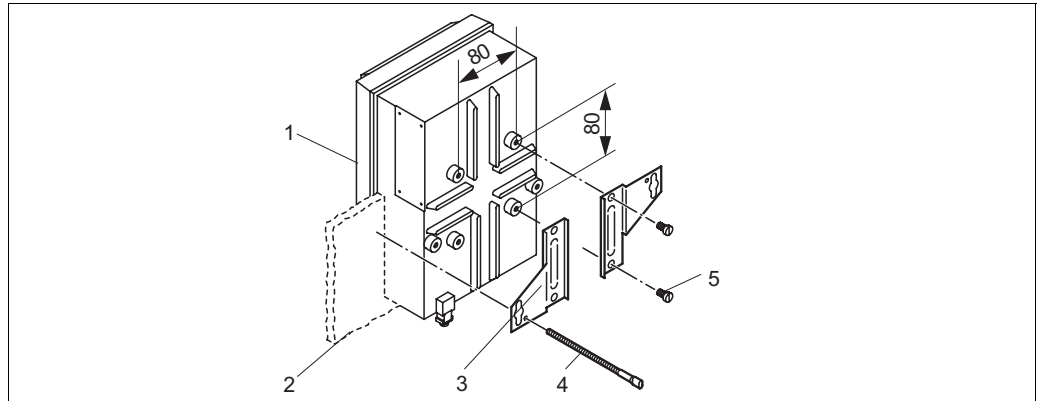

Fig. 11: Panel mounting

1. Make the necessary mounting cutout, measuring 161 x 241 mm (6.34" x 9.49"). The installation depth is 134 mm (5.28").
2. Unscrew the top housing section (item 1).
3. Secure the securing plates (item 3) to the transmitter housing base using the securing screws (item 5) in accordance with Fig. 11.
4. Secure the transmitter to the panel (item 2) using the clamping screws (item 4).
5. Place the flat seal (see "Accessories" section) on the housing base.
6. Screw the top housing section back on.

Post mounting

Proceed as follows to mount the transmitter to a post:

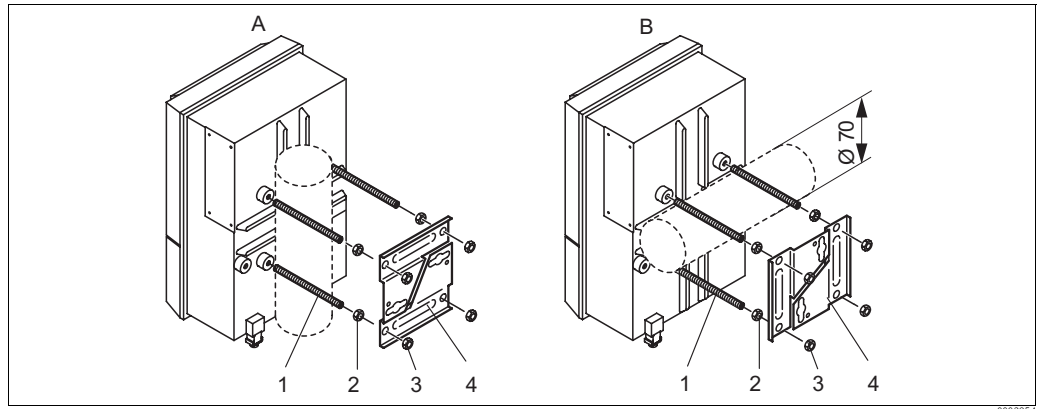

Fig. 12: Post mounting

- A Vertical mounting
- B Horizontal mounting

1. Screw the four securing screws (item 1) into the threaded openings on the transmitter.
2. Counter every securing screw with a nut (item 2).
3. Set the transmitter to the desired position on the post or pipe.
4. Push the securing plates (item 4) onto the securing screws in accordance with Fig. 12.
5. Screw a nut (item 3) onto each securing screw and tighten it so that the transmitter is securely fastened to the post or pipe.

You can also secure the field device to a square universal post in conjunction with the weather protection cover. These are available as accessories, see the "Accessories" section.

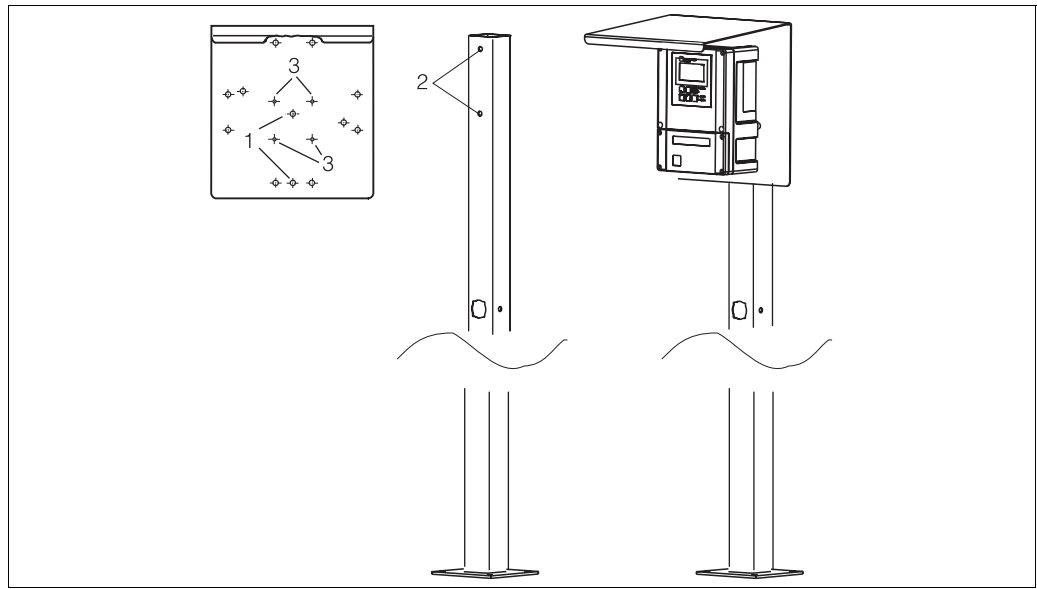

Fig. 13: Mounting the field device with a universal post and weather protection cover

Proceed as follows to mount the weather protection cover:

1. Screw the weather protection cover onto the upright post (bores 2) with 2 screws (bores 1).
2. Secure the field device to the weather protection cover. To do so, use the bores (3).

3.4 Post-installation check

- After installation, check the transmitter and the control unit for damage.
- Check whether the transmitter and control unit are protected against rain and direct sunshine.

4 Wiring



Warning!

- The electrical connection must only be carried out by an electrical technician.
- The electrical technician must have read and understood these Operating Instructions and must adhere to them.
- **Before beginning** the connection work, ensure no voltage is applied to any cable.

4.1 Electrical connection

4.1.1 Overview

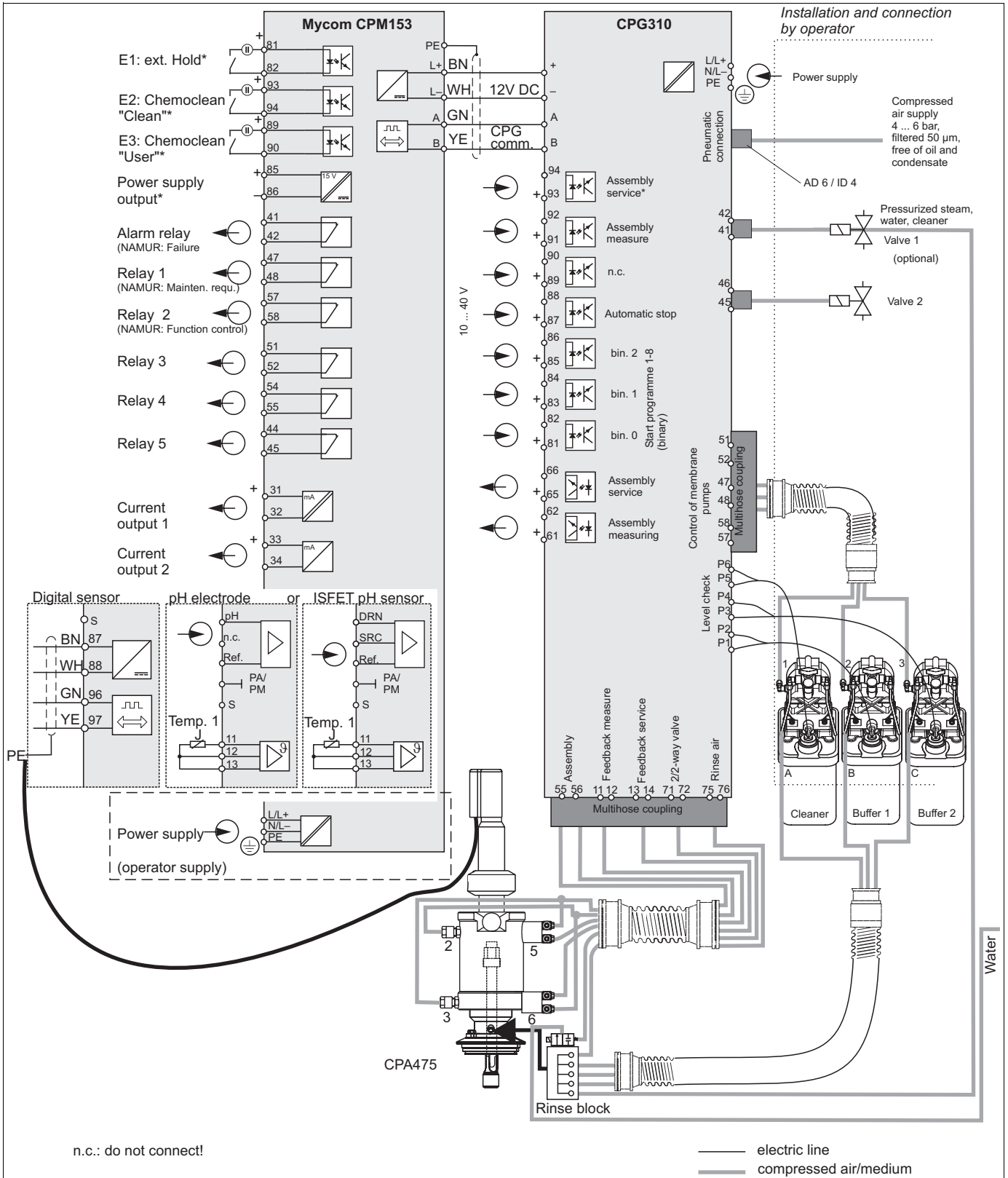

Fig. 14: Connecting in the non-hazardous area

4.1.2 Connection compartment sticker for CPG310 control unit

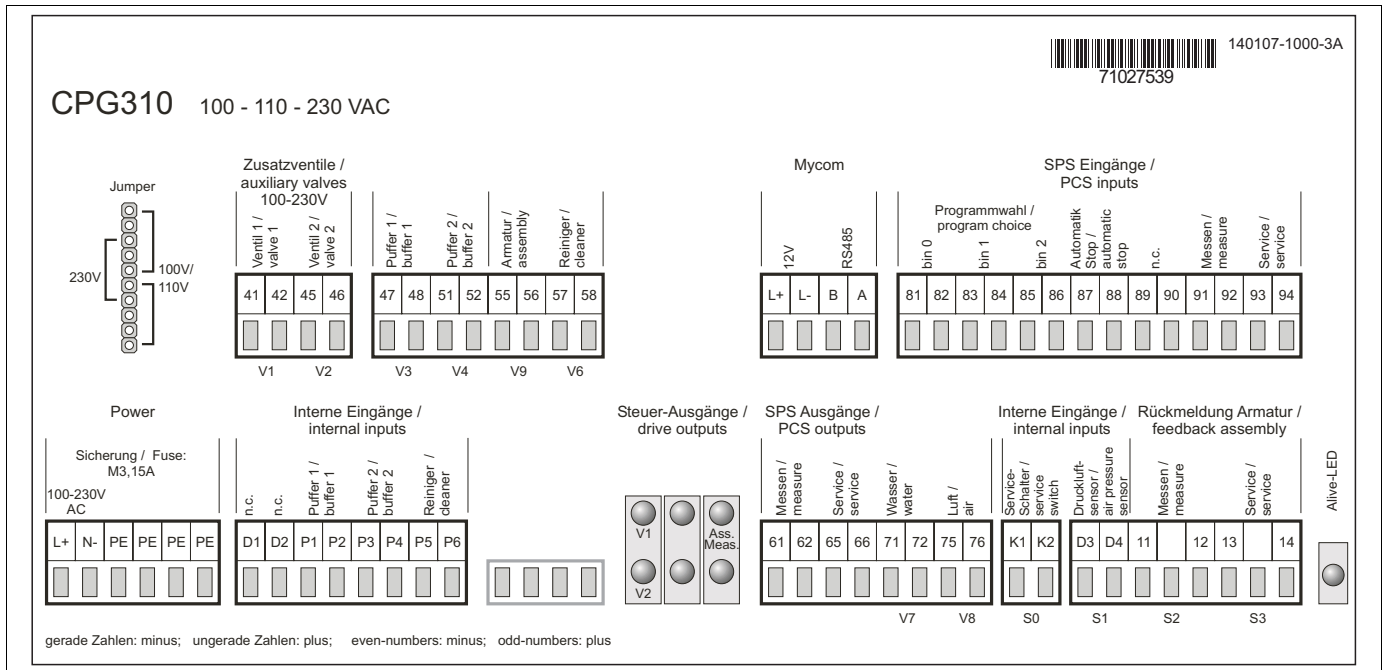

Fig. 15: Connection compartment sticker for CPG310, 100 / 110 / 230 V AC

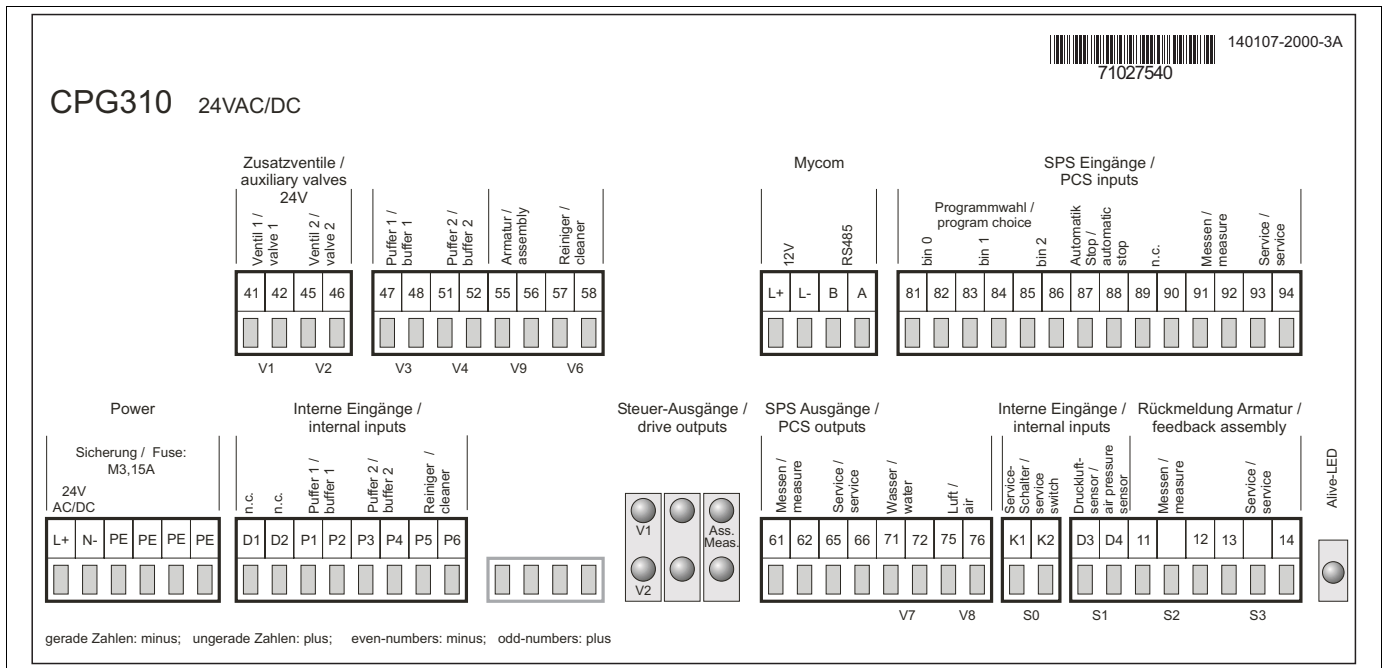

Fig. 16: Connection compartment sticker for CPG310, 24 V AC/DC

4.1.3 Connection compartment sticker, Mycom S CPM153

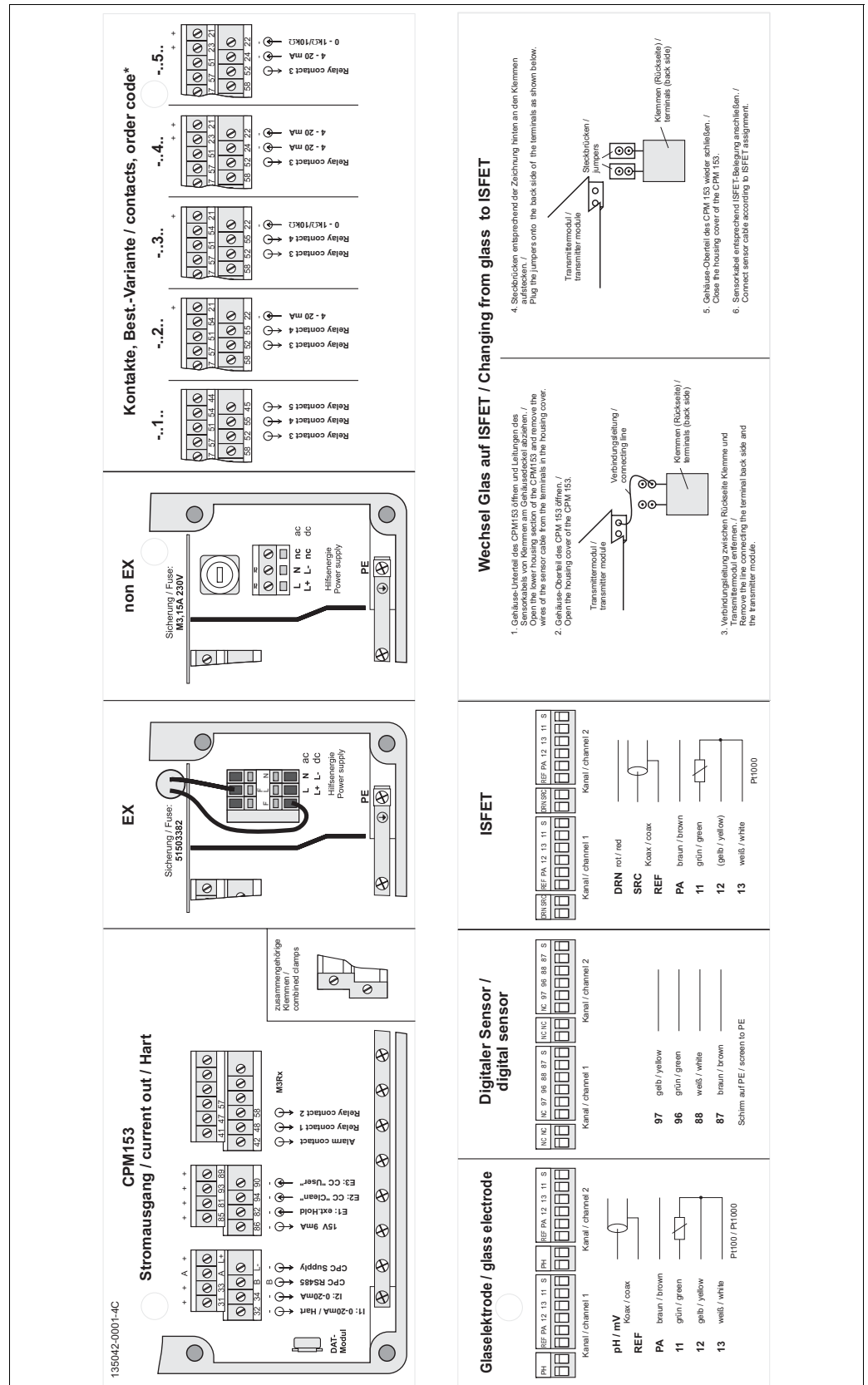

Fig. 17: Connection compartment sticker, Mycom S CPM153

- DRN Drain
- SRC Source
- REF Reference
- * Only order version --.1.. is applicable

4.1.4 Power supply and communication connection between transmitter and control unit

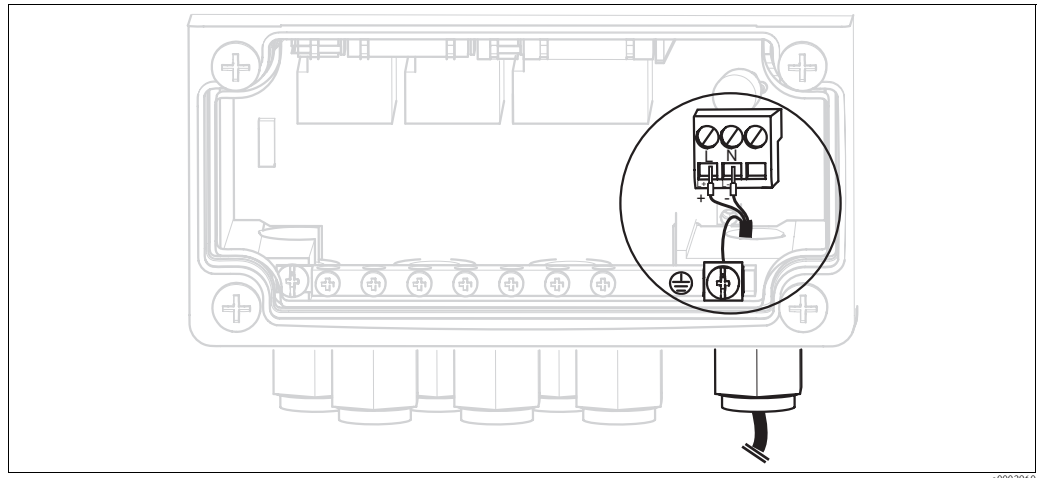

Fig. 18: Connecting power supply Mycom S

Mycom S power supply:

1. Guide the power cable through the right Pg cable gland and into the Mycom housing.
2. Connect the green/yellow core to the PE terminal.
3. Connect the two other cable cores to terminals "L" and "N".

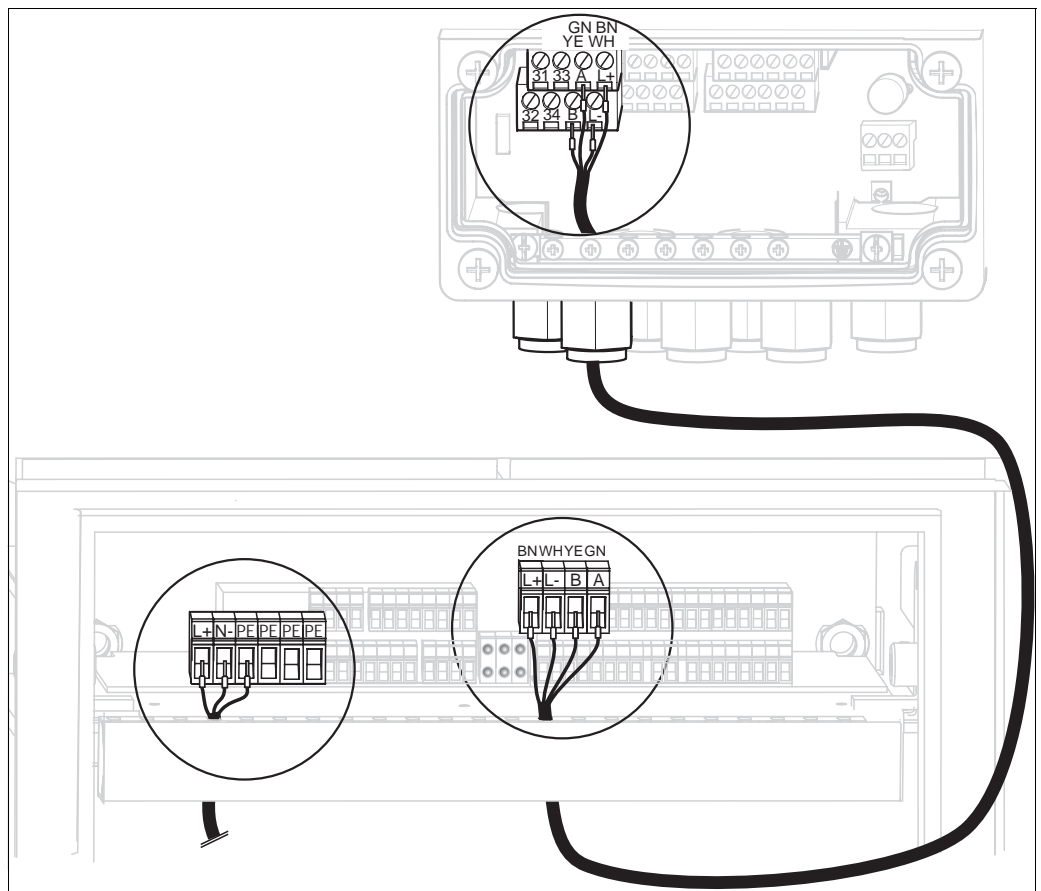

Fig. 19: Connecting power supply for control unit and communication connection

Control unit power supply

1. Guide the voltage cable through a suitable Pg gland and into the control unit housing.
2. Connect the green/yellow core to the PE terminal.
3. Connect the two other cable cores to terminals "L+" and "N-" (bottom terminal block, left).

Communication connection between Mycom and control unit

1. Guide the end of the communication cable with the black shield wire through a suitable Pg gland on Mycom.
2. Guide the other end of the communication cable through a Pg gland on the control unit.
3. Connect the cable cores as follows:

Cable core	Mycom connection	Control unit connection
Yellow (YE)	Terminal B	Terminal B
Green (GN)	Terminal A	Terminal A
White (WH)	Terminal L-	Terminal L-
Brown (BN)	Terminal L+	Terminal L+
Black (BK)	PE grounding bar	n.c.

4.1.5 Level probes for buffer and cleaner

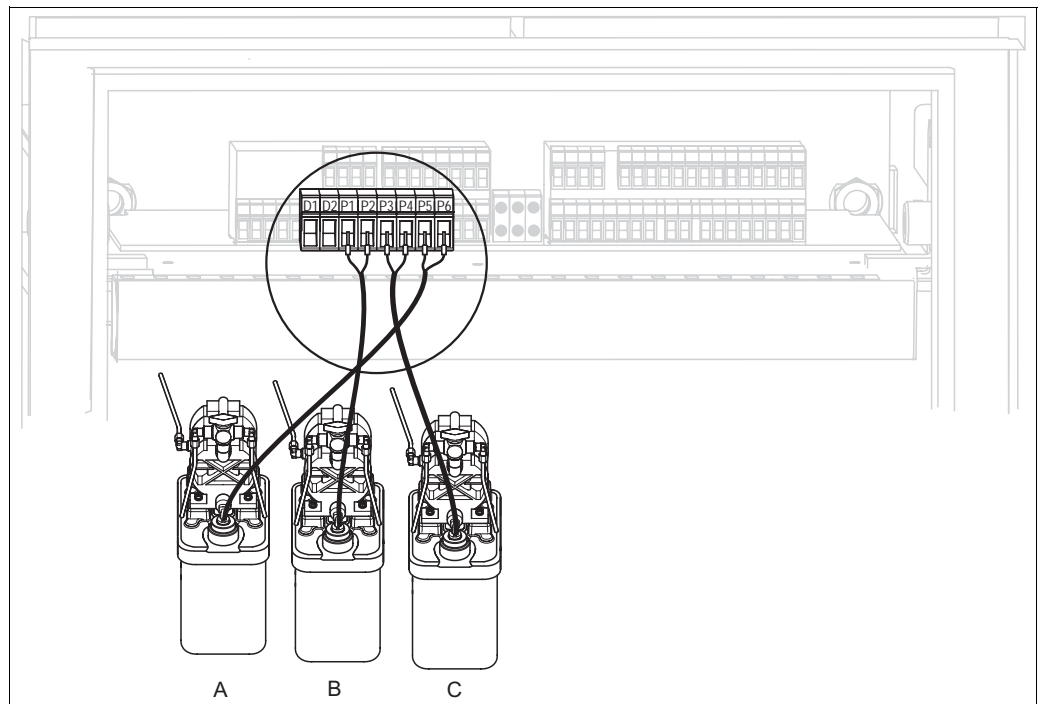

Fig. 20: Connecting level probes for buffer and cleaner

- A Cleaner
 B Buffer 1
 C Buffer 2

1. Guide the cables of the level probes for the buffer and cleaner through the threefold Pg gland behind the multithose connection (see Fig. 21).

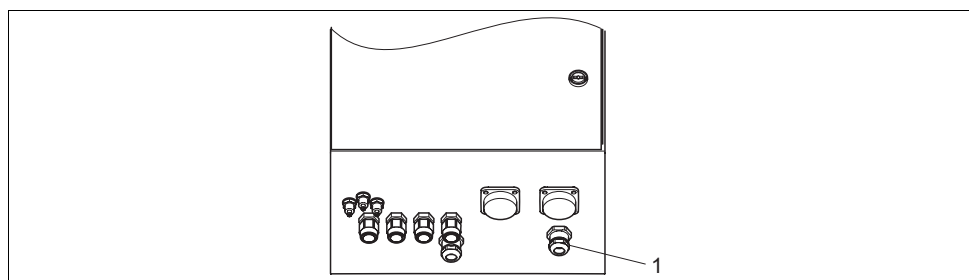

Fig. 21: Guiding the level probe cable

1 Threefold Pg gland

2. Connect the cable cores as follows. Polarity does not matter here:

Cable core	Control unit connection
Level probe, buffer 1	Terminal P1 and P2
Level probe, buffer 2	Terminal P3 and P4
Level probe, cleaner	Terminal P5 and P6

4.1.6 Analog sensors

Measuring cables

You require shielded special measuring cables to connect pH and redox sensors to the transmitter. You can use the following multicore and preterminated cable types:

Sensor type	Cable	Extension
Electrode without temperature sensor	CPK1	VBA / VBM box + CYK71 cable
Electrode with Pt 100 temperature sensor and TOP68 plug-in head	CPK9	VBA / VBM box + CYK71 cable
ISFET sensor with Pt 100 / Pt 1000 temperature sensor and TOP68 plug-in head	CPK12	VBA / VBM box + CYK12 cable
pH individual electrode with separate reference electrode and separate temperature sensor	CPK2	VBA / VBM box + PMK cable



Note!

Further information on the cables and junction boxes can be found in the "Accessories" section.

Preparing cables



Caution!

Danger of inaccuracy.

Make sure to protect connectors, terminals and cables against moisture.

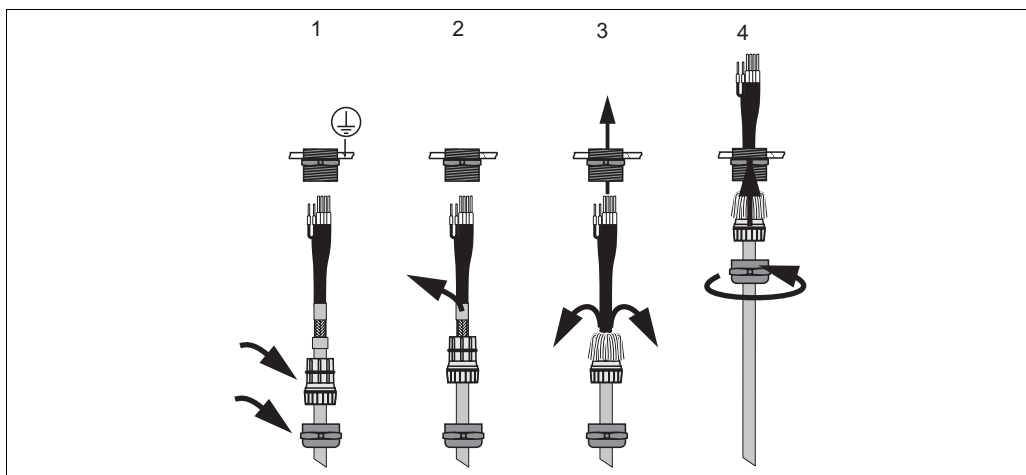

Fig. 22: Outer screen connection with metal cable gland

1. Slide the cable gland and the clamping ring over the cable.
2. Remove the inner insulation.
3. Remove the outer shield from the cable and fold it back over the clamping ring.
4. Guide the sensor cable through the cable opening of the device and screw the gland closed. Shield contacting takes place automatically here.

pH/redox glass electrodes

Connect the cable cores in the device as follows:

Connection with PML (symmetrical)

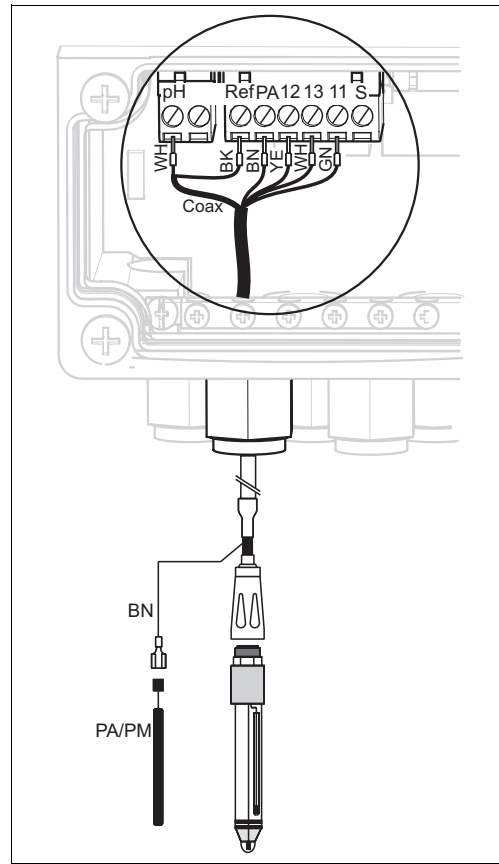

Fig. 23: Connecting pH glass electrode with PML

Connection without PML (unsymmetrical)

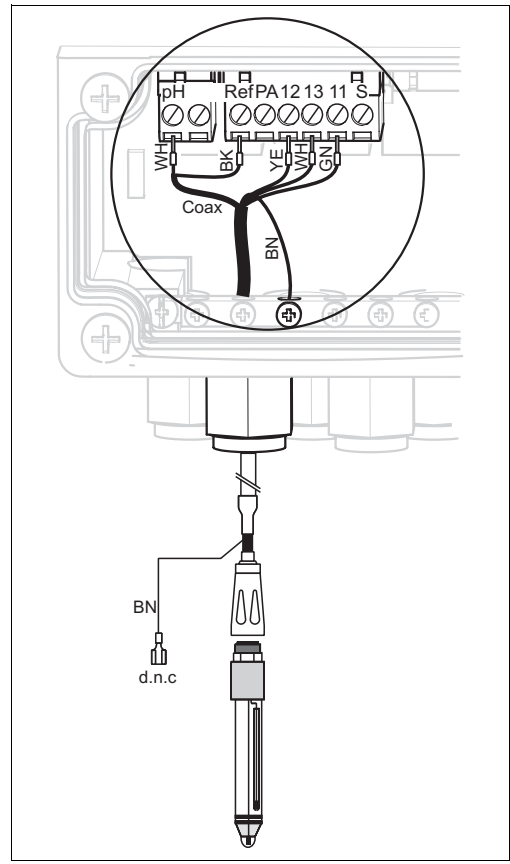

Fig. 24: Connecting pH glass electrode without PML
d.n.c. (do not connect)



Note!

- The yellow (YE), white (WH) and green (GN) cable cores do not apply when using CPK1.
- The outer shield of the cable is grounded by means of the metal gland.
- More information on pH measurement with PML and without PML is provided on the "Additional information" CD-ROM supplied.

ISFET sensors

Connect the cable cores in the device as follows:

Connection with PML (symmetrical)

Fig. 25: Connecting ISFET sensors with PML

Connection without PML (unsymmetrical)

Fig. 26: Connecting ISFET sensors without PML

d.n.c (do not connect)

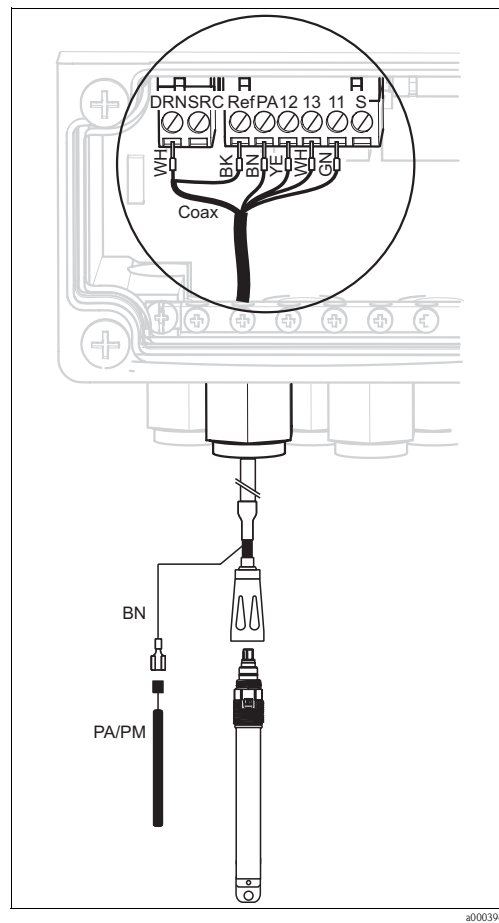
**Note!**

- The outer shield is grounded by means of the metal gland.
- More information on pH measurement with PML or without PML is provided on the "Additional information" CD-ROM supplied.

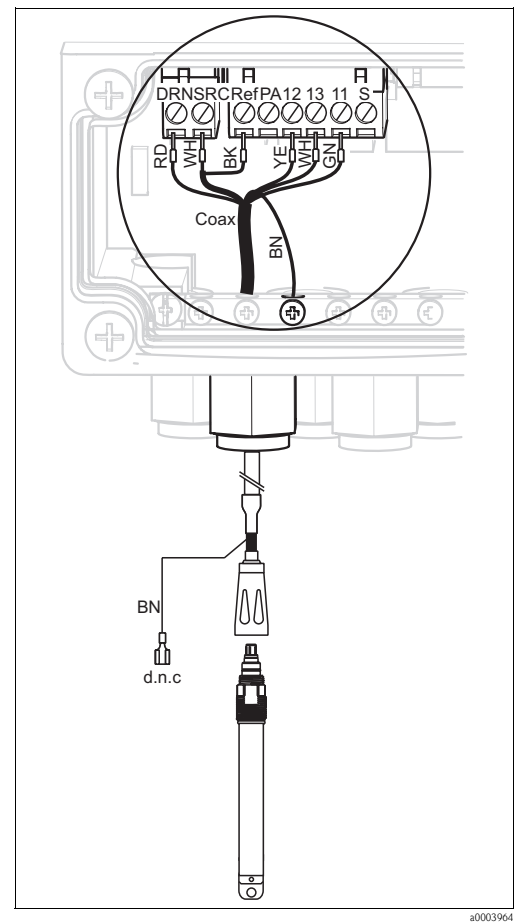
Changing the pH input from glass electrode to ISFET sensor

In the glass/ISFET version (CPC310-xx2xxxxxx), Topcal S is supplied for measuring with glass electrodes as standard.

Proceed as follows to switch the connection:

1. Open the bottom housing section of the device.
2. If a glass electrode is connected, disconnect the cores of the sensor cable.

3. Remove the "pH" terminal on the housing cover (see Fig. 27) from the device and replace it with the "DRN/SRC" terminal supplied.

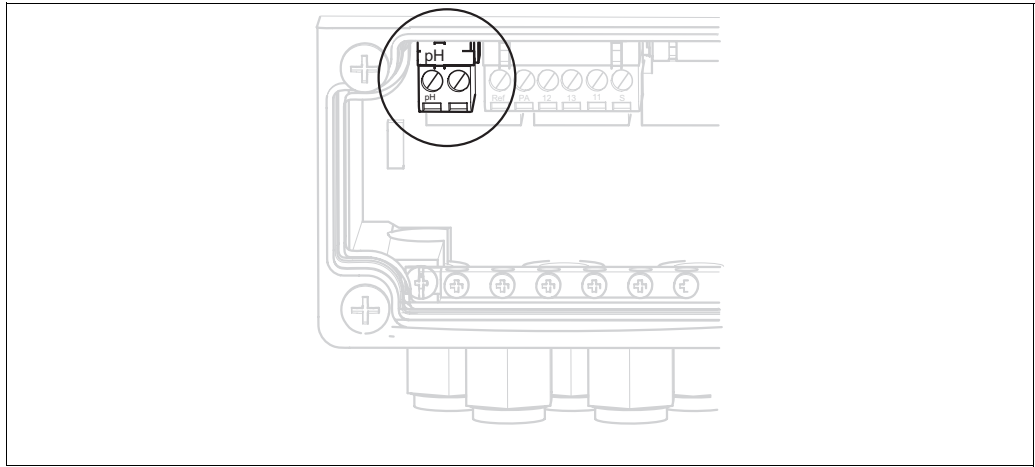

Fig. 27: pH terminal on housing cover

4. Open the top housing section of the device.
5. On the right-hand side of the housing cover, disconnect the red cable to the pH input at both ends (see Fig. 28).
6. Attach the jumpers supplied as illustrated in Fig. 29.
7. Connect the sensor cable in accordance with the ISFET assignment.
8. In the Quick Setup, change the electrode type to "ISFET".



Note!

Proceed accordingly for changing from ISFET sensors to glass electrodes.

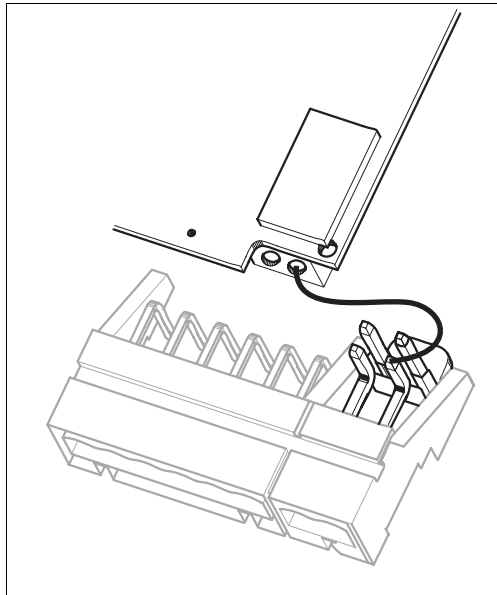

Fig. 28: pH input module in the housing cover with cable (red) for connecting glass electrodes

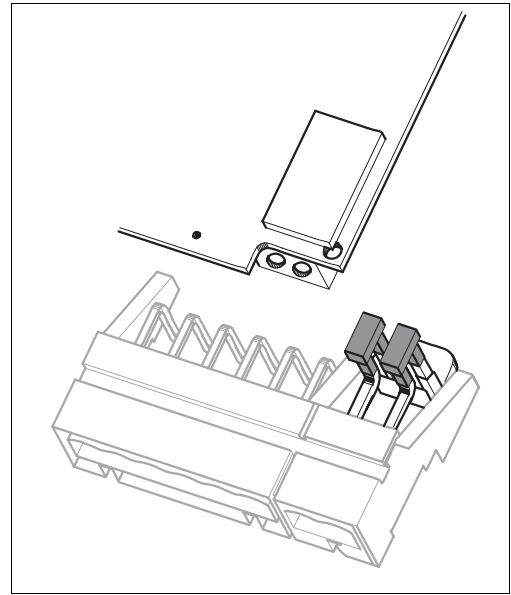

Fig. 29: pH input module in the housing cover with jumper for connecting ISFET sensors

4.1.7 Digital sensors with Memosens technology

Measuring cables

You require the Memosens CYK10 data cable to connect digital sensors:

Sensor type	Cable	Extension
Digital sensors with temperature sensor	CYK10	RM junction box + CYK81 cable

Preparing cables

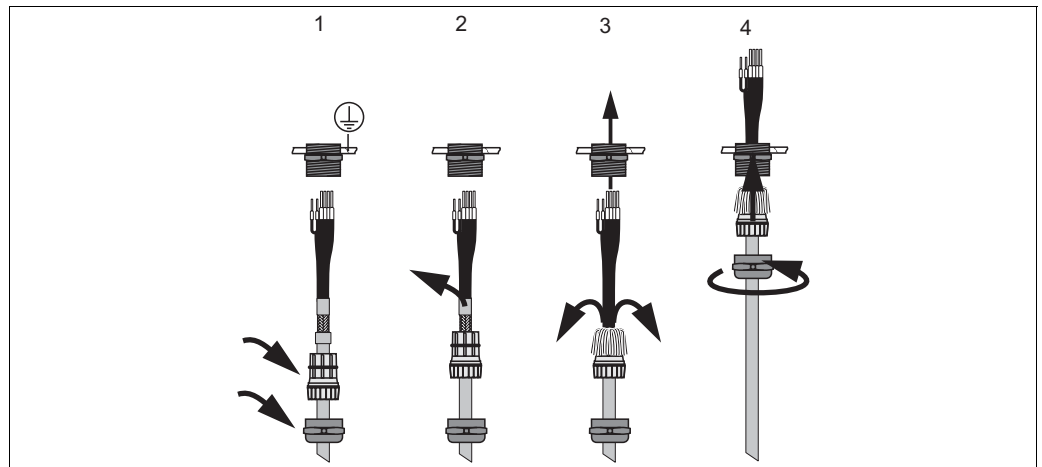

Fig. 30: Outer screen connection with metal cable gland

1. Slide the cable gland and the clamping ring over the cable.
2. Remove the inner insulation.
3. Remove the outer shield from the cable and fold it back over the clamping ring.
4. Guide the sensor cable through the cable opening of the device and screw the gland closed. Shield contacting takes place automatically here.

Connecting digital sensors

Connect the cable cores in the device as follows:



Fig. 31: Connecting digital sensors with Memosens technology



Note!

The outer shield of the cable is grounded by means of the metal gland.

4.1.8 Current outputs

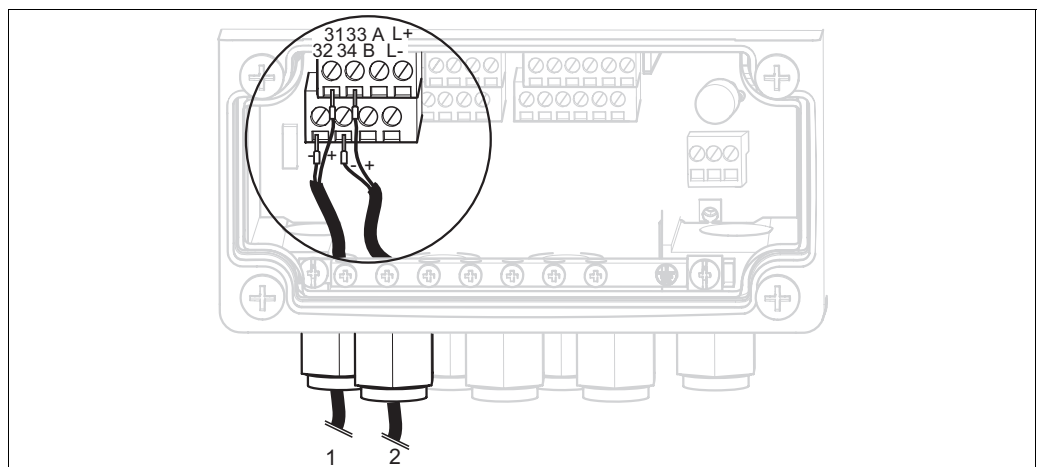

Fig. 32: Connecting current outputs

If you want to output the measured value to external switching units or a PLC, connect these devices to current outputs 1 and 2 of the transmitter.

You can also output a controller actuating variable by means of current output 2.

Current output coding

With device versions CPM153-AxA/Bxx (2 current outputs) and CPM153-AxC/Dxx (2 current outputs with HART), the current outputs can be operated as active or passive outputs. Jumpers on the controller module M3CH allow recoding.

For non-Ex instruments, these modules may be recoded to active outputs.



Caution!

Passive current outputs require external power supply.



Fig. 33: Coding for current outputs (Interior view of the housing upper section)

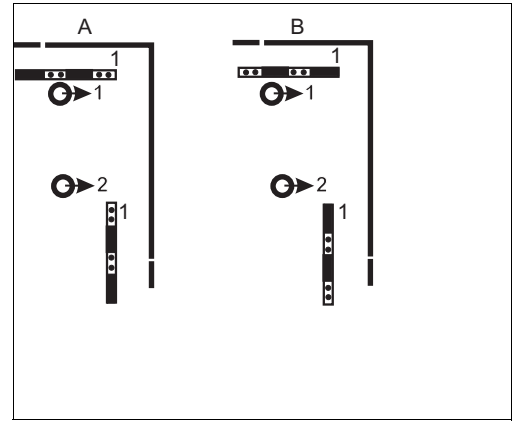

Fig. 34: Current output coding

- A Coding for passive output
- B Coding for active output

4.1.9 Mycom relay

In Mycom S CPM153, one fault-signaling contact and five additional contacts are available. You can use the additional contacts to control controllers, limit contactors and the supply of Chemoclean water and Chemoclean cleaner. The additional contacts are configured by means of the "Set up 1 > Relays" menu.

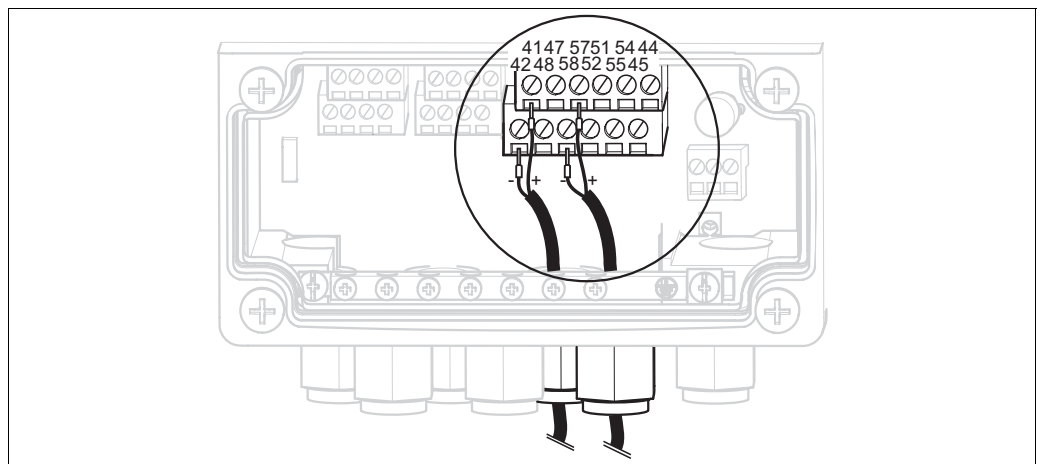

Fig. 35: Relay connection

Connect the relays as follows:

Contact function	Mycom S connection
Alarm	Terminals 41 and 42
Relay 1	Terminals 47 and 48
Relay 2	Terminals 57 and 58
Relay3	Terminals 51 and 52



Contact function	Mycom S connection
Relay 4	Terminals 54 and 55
Relay 5	Terminals 44 and 45

Please note the following with regard to assigning functions to the relays:

- The assignment of the functions to the relay in question can principally be freely configured. When using the NAMUR assignment, however, the functions for the alarm relay and the first two relays are specified (see NAMUR assignment below).
- The normally closed/normally open type of contact can be changed using the software.
- You can assign up to three relays to the controller.

NAMUR assignment

When using the NAMUR assignment (based on the recommendations of the interest group for process control technology in the chemical and pharmaceutical industry), the functions are specified for the relays as follows:

Relay	NAMUR assignment ON	Terminal
ALARM	Failure	41 42 
RELAY 1	Maintenance required	47 48 
RELAY 2	Function check	57 58 

Function check assignment

The function check as per NAMUR is active if:

- Calibration is active.
- The assembly is in the Service position.
- Mycom is configured.
- A Topcal cleaning and calibration program is running.
- A Chemoclean program is running.
- An error occurs to which the function check is assigned (for assignment, see the "System errors" section).

4.1.10 External inputs (PLC to CPG310) and outputs (CPG310 to PLC)

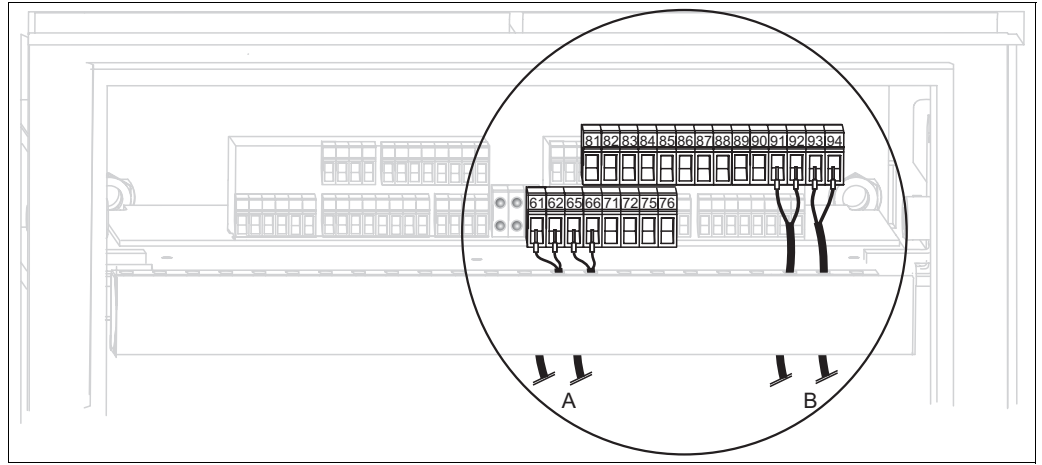

Fig. 36: Connecting external inputs and outputs, e.g. external assembly position control and assembly feedback

- A External outputs
B External inputs

External inputs

- If you are controlling the position of the assembly by means of an external PLC, connect the controller as follows:

Controller	Control unit connection
"Measure" position	Terminals 91 and 92
"Service" position	Terminals 93 and 94

- If you want to control the cleaning and calibration programs of Topcal S by means of an external PLC, connect the binary contacts of the control unit. The coding for the individual calibration and cleaning programs is provided in the "Set up 2 - Topcal S" section.

Contact	Control unit connection
Contact 0	Terminals 81 and 82
Contact 1	Terminals 83 and 84
Contact 2	Terminals 85 and 86

- If you want to stop program cycles by means of an external PLC, connect the controller for the automatic stop system to terminals "87" and "88". In this way, the program running is ended and no new program is started as long as a signal is present at terminals 87/88. The "Interval" program is stopped immediately.

External outputs

- If you want to report the position of the assembly to an external PLC, connect the outputs of the control unit as follows:

Feedback	Control unit connection
"Assembly in Measuring position" feedback signal	Terminals 61 and 62
"Assembly in Service position" feedback signal	Terminals 65 and 66

4.1.11 External inputs (PLC to Mycom)

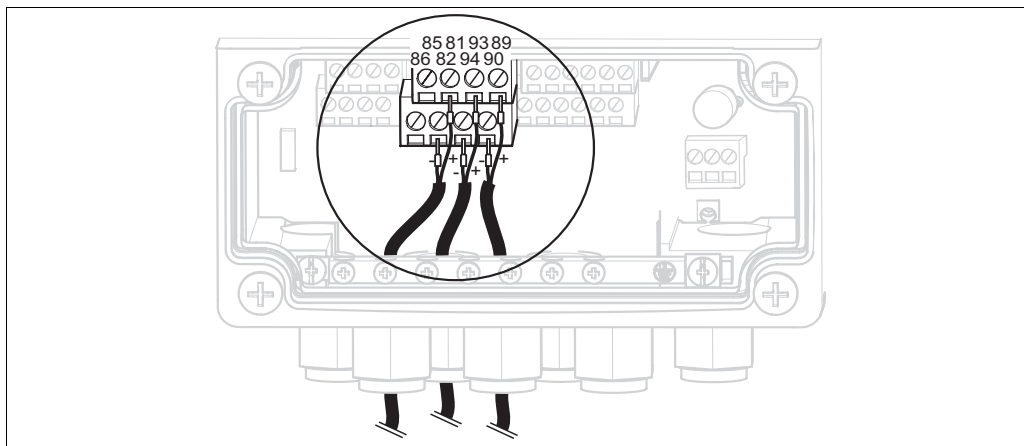

Fig. 37: Connecting external inputs

1. If you want to activate the hold function for Mycom by means of an external PLC, connect the input to terminals 81 and 82 of the device (power supply necessary).
2. If you want to control the Chemoclean programs by means of an external PLC, connect the inputs as follows:

Chemoclean program	Mycom connection
"Clean" program	Terminals 93 and 94
"User" program	Terminals 89 and 90

4.1.12 Inductive limit position switch

The system is supplied with pneumatic feedback systems for the assembly position as standard. If you are using inductive limit position switches, connect them as outlined in the following instructions.

Inductive limit position switches of the Cleanfit CPA471, CPA472, CPA475 assemblies

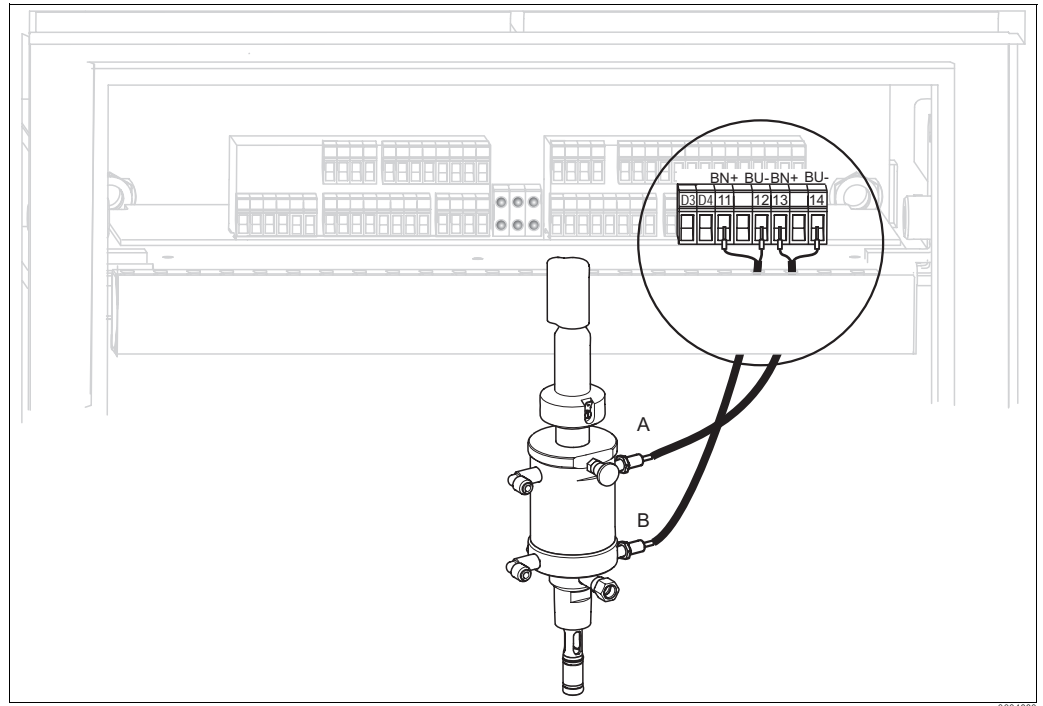

Fig. 38: Connecting inductive limit position switches of the CPA471, CPA472, CPA475 assemblies

- A "Service" feedback signal
 B "Measure" feedback signal

1. If you are using a CPA471, CPA472 or CPA475 with inductive limit position switches for reporting the assembly position, release the existing cable from terminals 11 ... 14.
2. Connect the upper limit position switch (A) for the "Service" feedback signal:

Cable core	Control unit connection
Brown (BN)	Terminal 13 (+)
Blue (BU)	Terminal 14 (-)

3. Connect the lower limit position switch (B) for the "Measure" feedback signal:

Cable core	Control unit connection
Brown (BN)	Terminal 11 (+)
Blue (BU)	Terminal 12 (-)

Inductive limit position switches of the CPA473, CPA474 assemblies

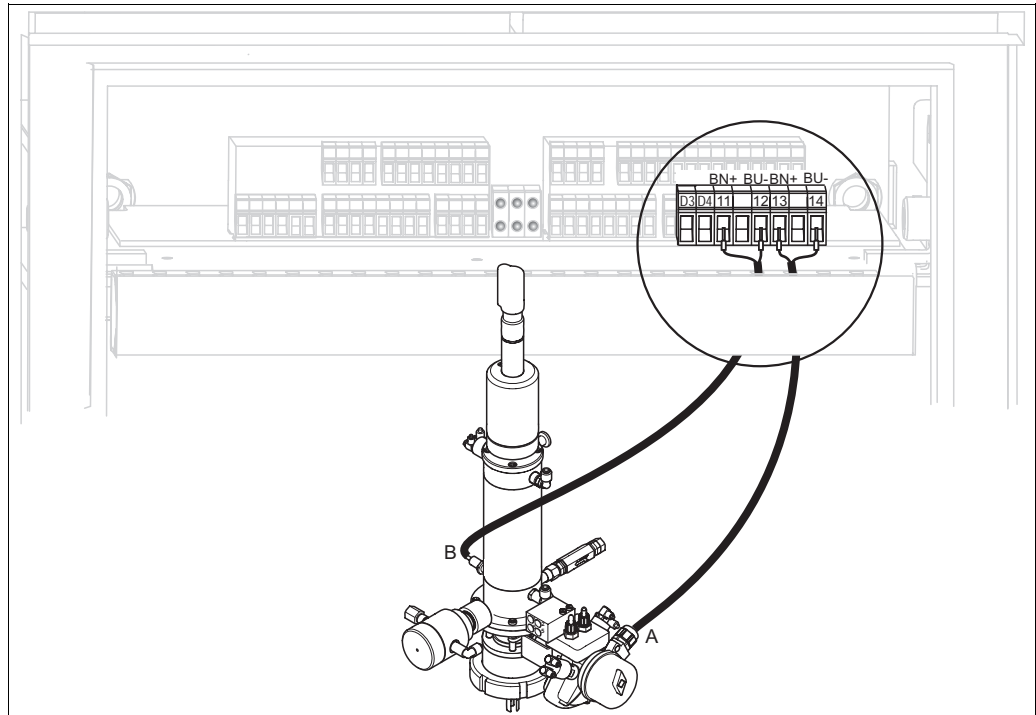

Fig. 39: Connecting inductive limit position switches of the CPA473, CPA474 assemblies

- A "Service" feedback signal
- B "Measure" feedback signal

1. If you are using a CPA473 or CPA474 assembly with inductive limit position switches for reporting the assembly position, release the existing cable from terminals 11 ... 14.
2. Connect the limit position switch (A), located beside the ball valve, for the "Service" feedback signal:

Cable core	Control unit connection
Brown (BN)	Terminal 13 (+)
Blue (BU)	Terminal 14 (-)

3. Connect the limit position switch (B), located on the rear of the ball valve, for the "Measure" feedback signal:

Cable core	Control unit connection
Brown (BN)	Terminal 11 (+)
Blue (BU)	Terminal 12 (-)

4.2 Post-connection check

After the electrical connection, carry out the following checks:

Device condition and specifications	Notes
Are the transmitter and cable damaged externally?	Visual inspection

Electrical connection	Notes
Does the supply voltage match the specifications on the nameplate?	100 ... 230 V wide area 24 V AC / DC
Do the cables used fulfill the required specifications?	Use a genuine Endress+Hauser cable for connecting the sensor, see "Accessories" section.
Are the mounted cables strain-relieved?	
Is the cable type route completely isolated?	Along the whole cable length, run the power supply and signal line cables separately to avoid any mutual influence. Separate cable channels are best.
No loops and crossovers in the cable run?	
Are the signal cables correctly connected as per the wiring diagram?	
Are all the screw terminals tightened?	
Are all the cable entries installed, tightened and sealed? Cable run with "water trap"?	"Water trap": Cable circuit hanging down so that water can drip off.
Are the PE distributor rails grounded (if present)?	Grounding takes place at the point of installation
Are all the housing covers installed and firmly tightened?	Check seals for damage.

5 Medium connection

5.1 Compressed air pipe and additional valves

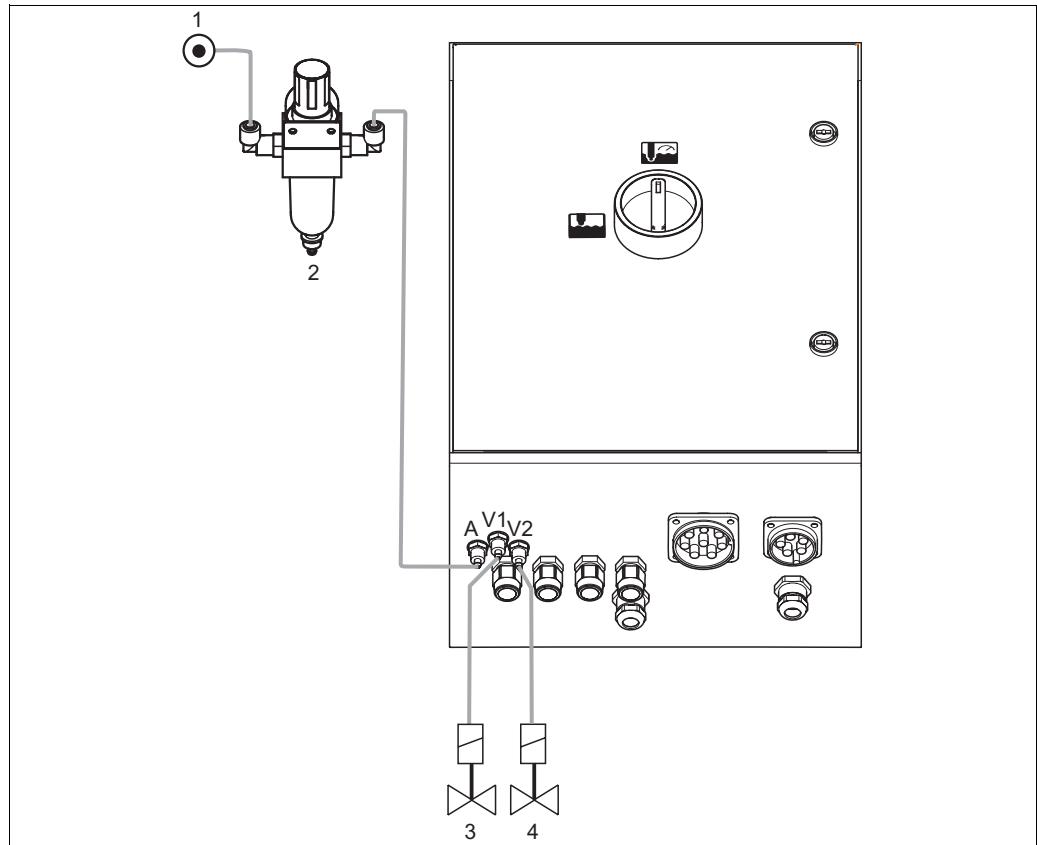

Fig. 40: Connecting compressed air supply and controlling additional valves

- 1 Compressed air
- 2 Pressure reduction valve
- 3 Additional valve 1
- 4 Additional valve 2

Compressed air supply



Caution!

Note the following points when connecting:

- The compressed air pipe must be provided at the point of installation.
- Pay attention to the installation direction of the pressure reduction valve. You can identify the flow direction from the arrows at the top of the square block of the valve.
- The optimum air pressure is 5 bar (73 psi).
- The air must be filtered (50 µm) and free from oil and condensate. The pipe diameter must be at least 10 mm (0.39").

Connect the output side of the pressure reduction valve to connection A.

Additional valves

Connect the additional valves as follows:

Valve number	Function
V1	Control of additional valve 1 for sealing water etc.
V2	Control of additional valve 2 for sealing water etc.

You can use the additional valves for "Sealing water" for example. The valves are assigned in "Set up 2 > Topcal > Config. Topcal". Activate the sealing water in "Set up 2 > Topcal > Activate Topcal".

What is sealing water?

In processes where the medium is fibrous or tends to stick, assemblies with a ball valve for shutting off the medium are used e.g. Cleanfit P CPA473 or CPA474. To keep the rinse chamber free of medium, the sealing water valve opens automatically before the assembly moves out of the process. The counterpressure in the rinse chamber caused by the sealing water prevents the ingress of medium into the chamber. The sealing water pressure must then be greater than the pressure of the medium. The time the sealing water runs before and after moving the assembly can be set individually.

5.2 Water pipe and rinse chamber

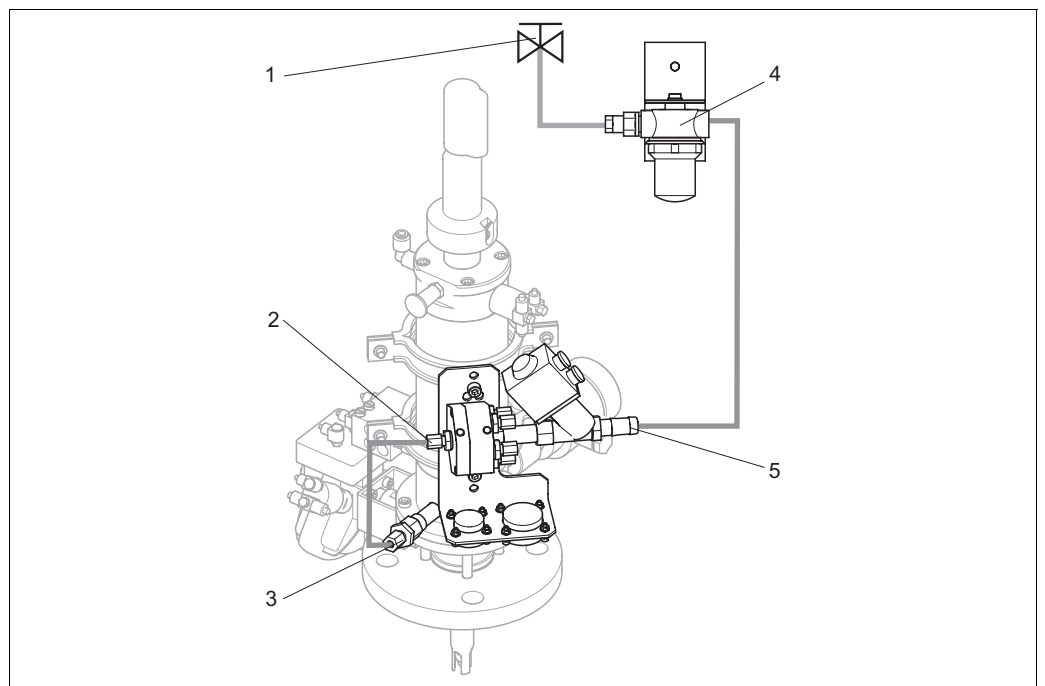

Fig. 41: Connecting rinsing block to rinse chamber and water connection

- 1 Rinse water
- 2 Rinsing block, rinse chamber connection
- 3 Assembly, rinse chamber connection
- 4 Water filter
- 5 Water connection

Connecting the rinse chamber

Connect the rinse chamber connection at the rinsing block (2) to the rinse connection of the assembly (3).

Connecting rinse water



Caution!

Note the following points when connecting the water:





- The rinse water pipe must be provided at the point of installation.
- The water pressure must be 3 to 6 bar (43.5 to 87 psi).

Proceed as follows to connect the water:

1. Rinse the pipe thoroughly.
2. Connect the rinse water (1) to the water filter (4) supplied. The water filter filters particles up to 100 µm out of the water.
3. Connect the output of the water filter to the water connection of the rinsing block (5).

5.3 Multihoses

The delivery contains four multihoses. Please observe the table below to connect the hoses correctly.

Hose	Function
 M1 Diameter Pg 29; length: 5 (16 ft) or 10 m (33 ft)	Compressed air <ul style="list-style-type: none"> ■ To move the assembly ■ To confirm the position ■ To control the 2/2-way valve for rinse water ■ Purging air
 M2 Diameter Pg 21; length: 2.5 m (8.2 ft)	Compressed air for controlling <ul style="list-style-type: none"> ■ Membrane pump for cleaner ■ Membrane pump for buffer 1 ■ Membrane pump for buffer 2
 M3 Diameter Pg 21; length: 5 (16 ft) or 10 m (33 ft)	Transporting <ul style="list-style-type: none"> ■ Cleaner ■ Buffer 1 ■ Buffer 2
 M4 Diameter Pg 21; length: 1.5 m (4.9 ft)	Venting <ul style="list-style-type: none"> ■ Membrane pump for cleaner ■ Membrane pump for buffer 1 ■ Membrane pump for buffer 2

5.3.1 Connecting multihoses

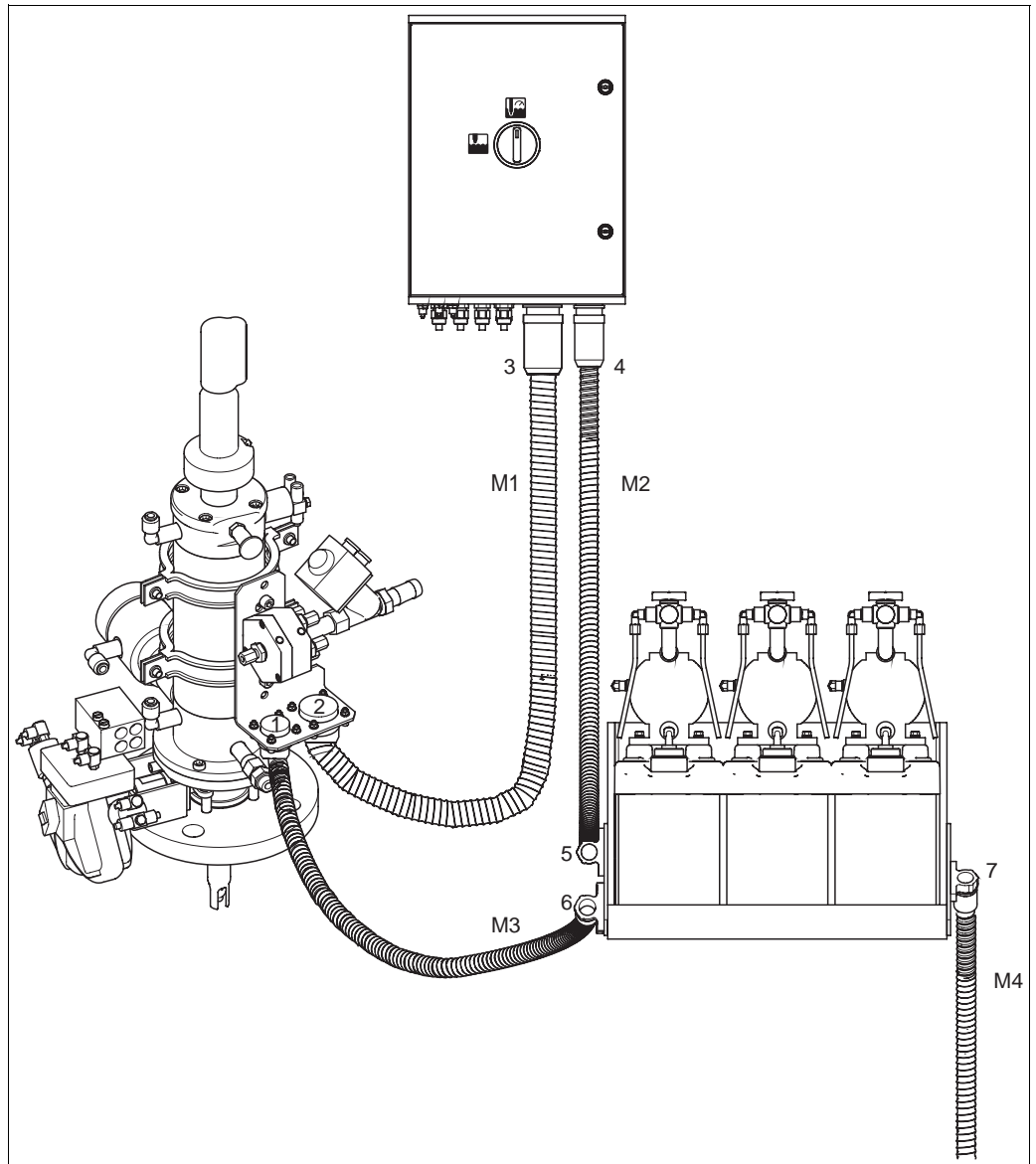

Fig. 42: Connecting multihoses



Caution!
Make sure you connect the multihoses strain-relieved without any buckling.

Connect the multihoses as follows:

Hose number	Topcal housing connection	Assembly connection	Canister tray connection
M1	Pg 29 bayonet lock (3)	Pg 29 bayonet lock (2)	
M2	Pg 21 bayonet lock (4)		Upper clamp (5)
M3		Pg 21 bayonet lock (1)	Lower clamp (6)
M4			Single clamp (7)

5.4 Assemblies

5.4.1 Cleanfit CPA471/472/475

With pneumatic limit position switches

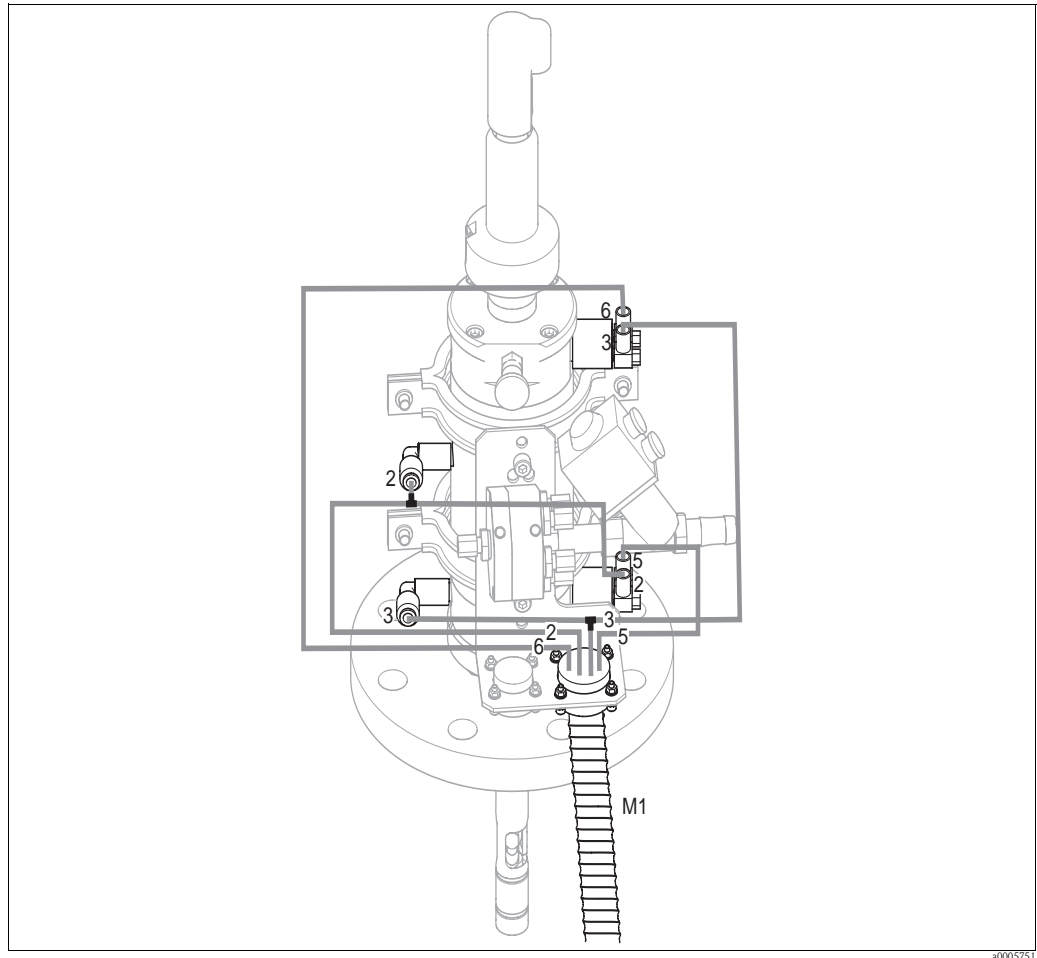

Fig. 43: Connecting CPA471, CPA472, CPA475 compressed air control with pneumatic limit position switches

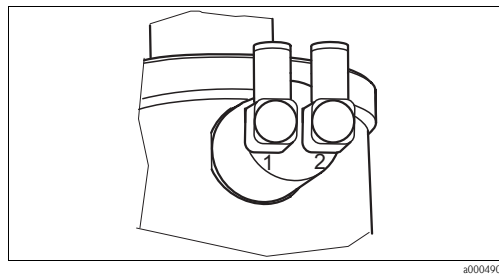

Fig. 44: Pneumatic limit position switch

- 1 Input
- 2 Output

Connecting pneumatic assembly control system

Connect the connections for moving the assembly and for position confirmation as follows:

Hose number	Function	Assembly connection
5	"Measure" position confirmation	Lower limit position switch - output (=2)
2	Move to "Measuring" position	Lower limit position switch - input (=1) and upper G $\frac{1}{4}$ coupling (via T-piece)
6	"Service" position confirmation	Upper limit position switch - output (=2)
3	Move to "Service" position	Upper limit position switch - input (=1) and lower G $\frac{1}{4}$ coupling (via T-piece)

With inductive limit position switches

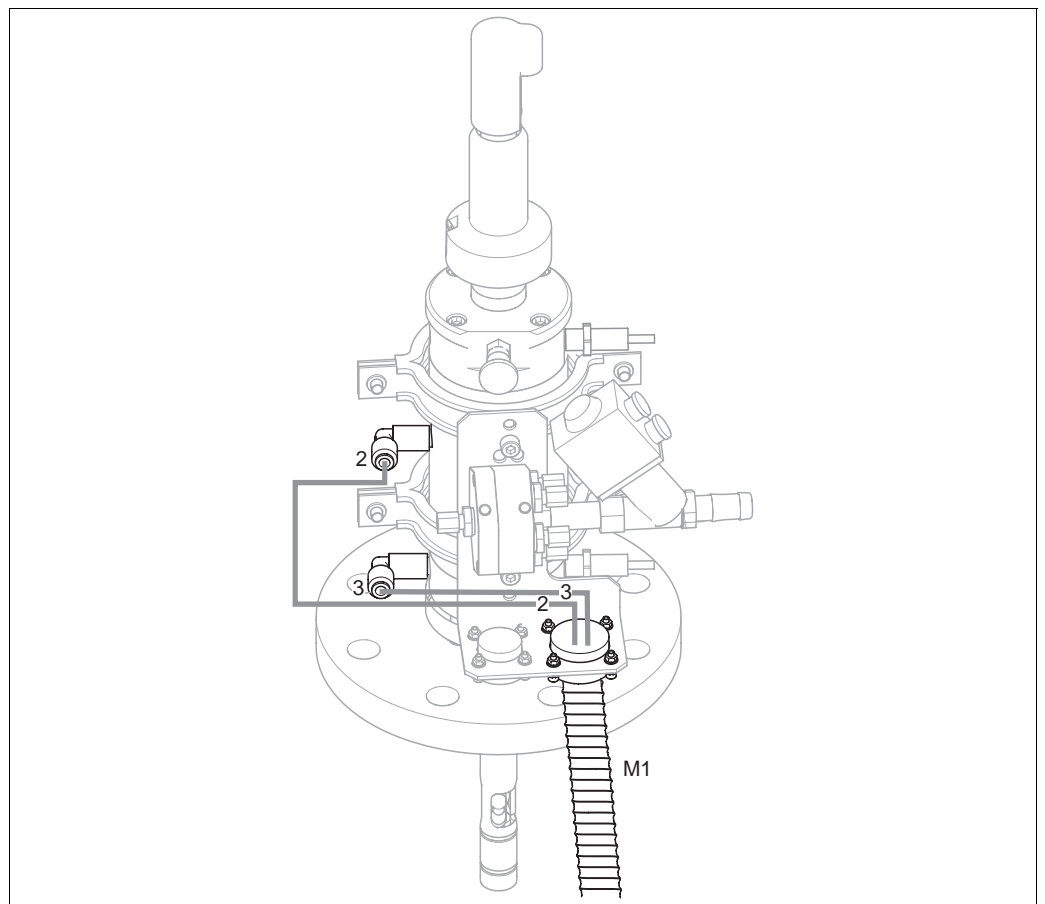

Fig. 45: Connecting CPA471, CPA472, CPA475 compressed air control with inductive limit position switches

Connecting pneumatic assembly control system

Connect the connections for moving the assembly as follows:

Hose number	Function	Assembly connection
2	Move to "Measuring" position	Upper G $\frac{1}{4}$ coupling
3	Move to "Service" position	Lower G $\frac{1}{4}$ coupling

5.4.2 Cleanfit CPA473/474

With pneumatic limit position switches

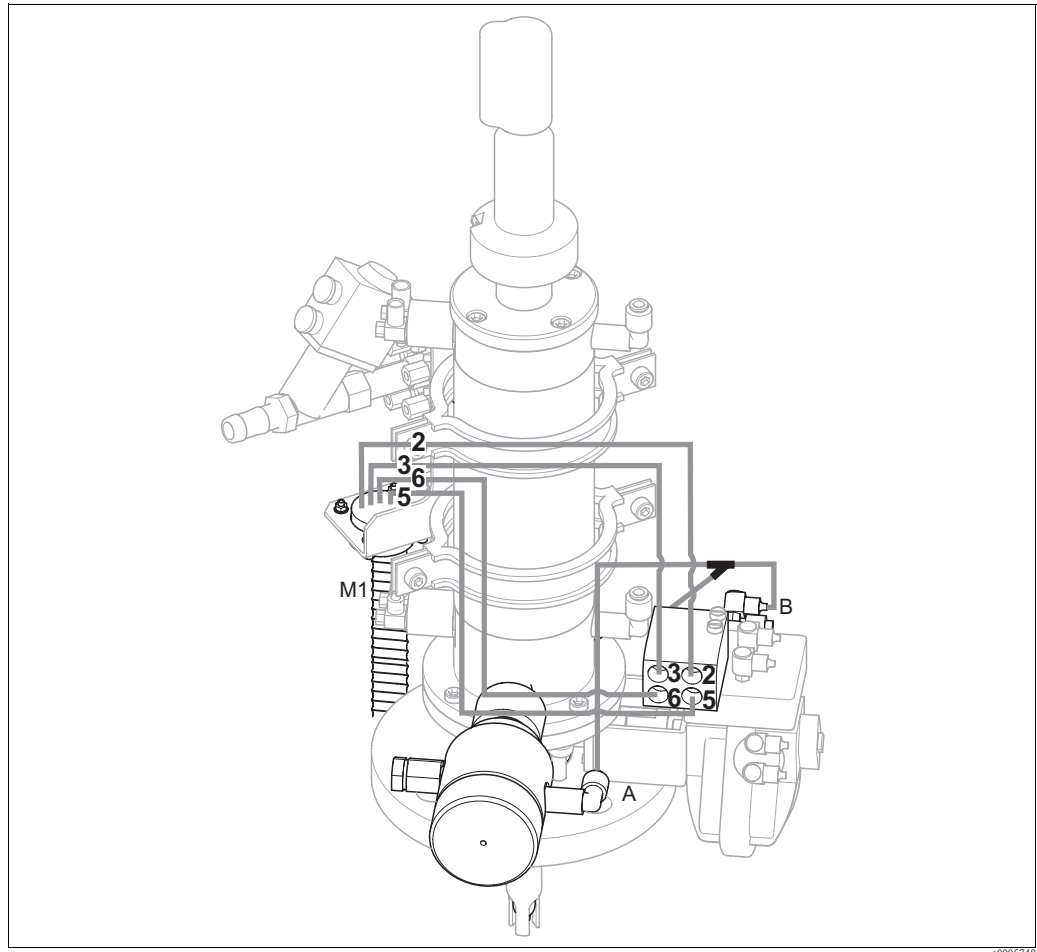

Fig. 46: Connecting compressed air for controlling CPA473, CPA474 assemblies

The assembly is delivered with hoses ready connected. You just have to connect the compressed air for the pneumatic operation of the ball valve and the outputs for pneumatic feedback from the multihose M1 to the pneumatic connection block:

Hose number	Function	Pneumatic connection block
5	"Measure" position confirmation	Connection No. 5
2	Move to "Measuring" position	Connection No. 2
6	"Service" position confirmation	Connection No. 6
3	Move to "Service" position	Connection No. 3



Note!

If you are using a pneumatic outlet safety seal:

- Cut the compressed air pipe from the pneumatic connection block, input 6, to the limit position switch of the ball valve drive (B).
- Insert the two ends into the Y-piece supplied.
- Connect the third connection of the Y-piece to the compressed air connection of the outlet safety seal (A).

With inductive limit position switches

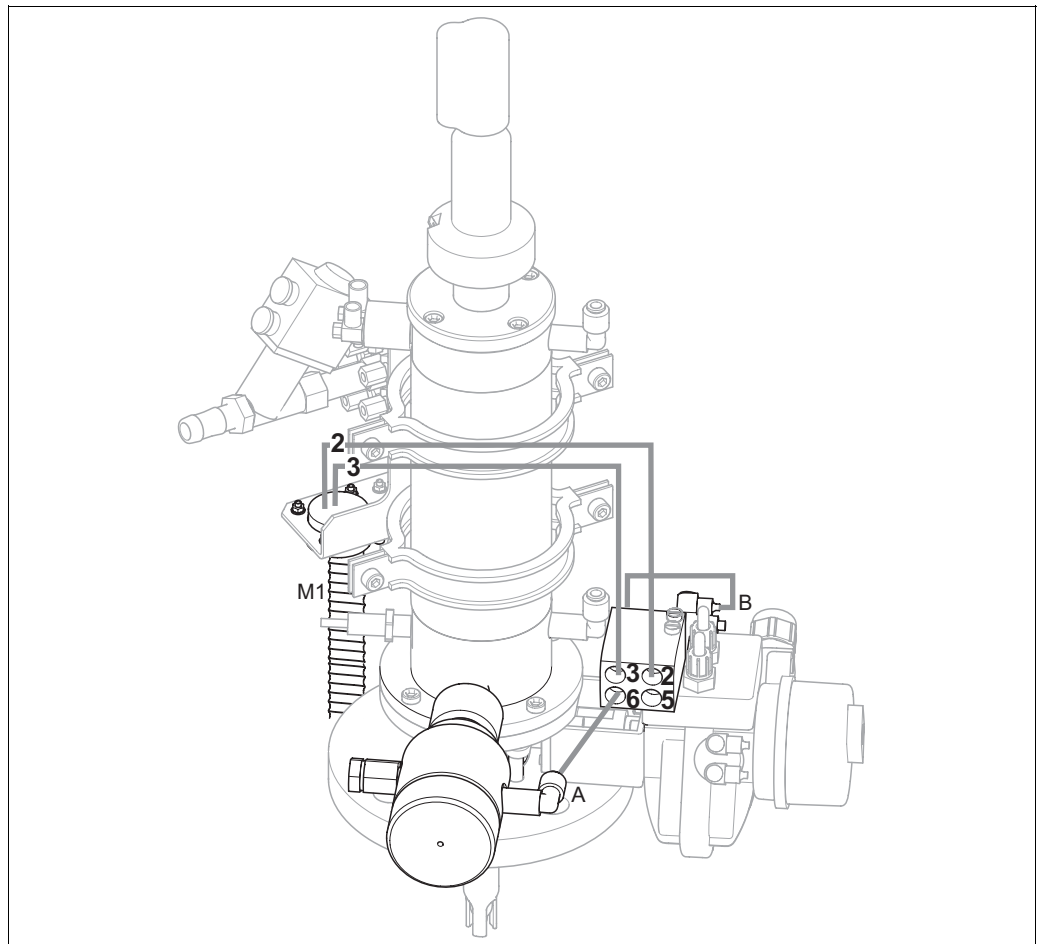

Fig. 47: Connecting CPA473, CPA474 compressed air control system with inductive limit position switches

Pneumatic assembly control system

The assembly is delivered with hoses ready connected. You just have to connect the compressed air for pneumatic operation of the ball valve:

Hose number	Function	Pneumatic connection block
2	Move to "Measuring" position	Connection No. 2
3	Move to "Service" position	Connection No. 3



Note!

If you are using a pneumatic outlet safety seal:

- Connect the pneumatic limit position switch (B) (marked with "2" (= output)) of the ball valve to **input 6** of the pneumatic connection block.
- Connect **output 6** of the pneumatic connection block to the compressed air connection of the outlet safety seal (A).

5.5 Pumps

5.5.1 Compressed air control

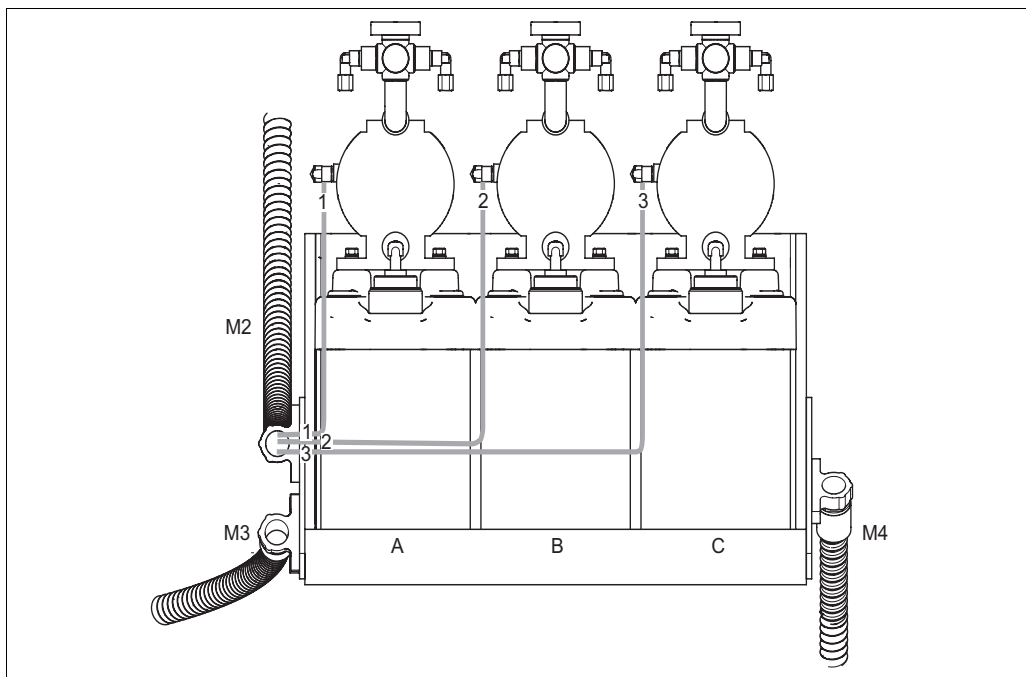

Fig. 48: Compressed air control of the membrane pumps

- A Cleaner
- B Buffer 1
- C Buffer 2

Connect the individual hoses as follows for compressed air control of the membrane pumps:

Multihose	Hose number	Membrane pump connection
M2	1	Cleaner compressed air connection
M2	2	Buffer 1 compressed air connection
M2	3	Buffer 2 compressed air connection

5.5.2 Buffer and cleaner

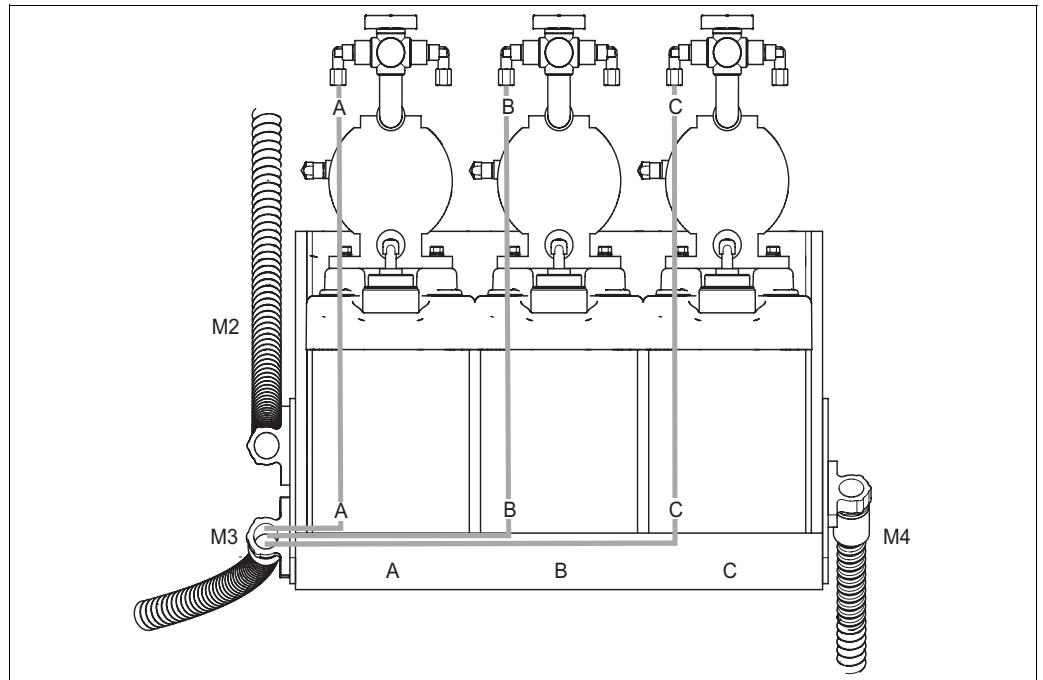

Fig. 49: Medium connection of the membrane pumps

- A Cleaner
- B Buffer 1
- C Buffer 2

Connect the individual hoses as follows for transporting buffer and cleaner:

Multihose	Hose number	Membrane pump connection
M3	A	Cleaner medium connection
M3	B	Buffer 1 medium connection
M3	C	Buffer 2 medium connection

5.5.3 Venting

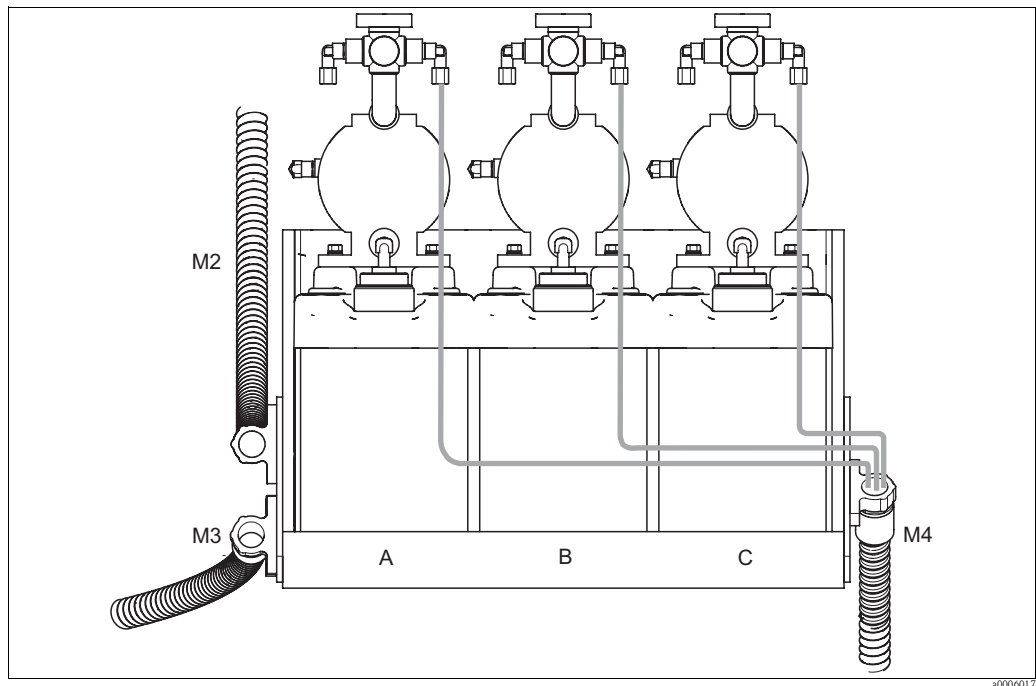

Fig. 50: Venting membrane pumps

- A Cleaner
- B Buffer 1
- C Buffer 2

To vent the membrane pumps, connect the individual hoses of multihose M4 to the vent connections of the three membrane pumps. No specific order has to be followed.

5.6 Post-connection check

Device condition and specifications	Notes
Are all the hoses firmly mounted and leaktight?	Visual inspection
Are the multihoses routed in such a way that they are protected?	Use protective pipes where necessary.

6 Operation

6.1 Display and operating elements

6.1.1 Display

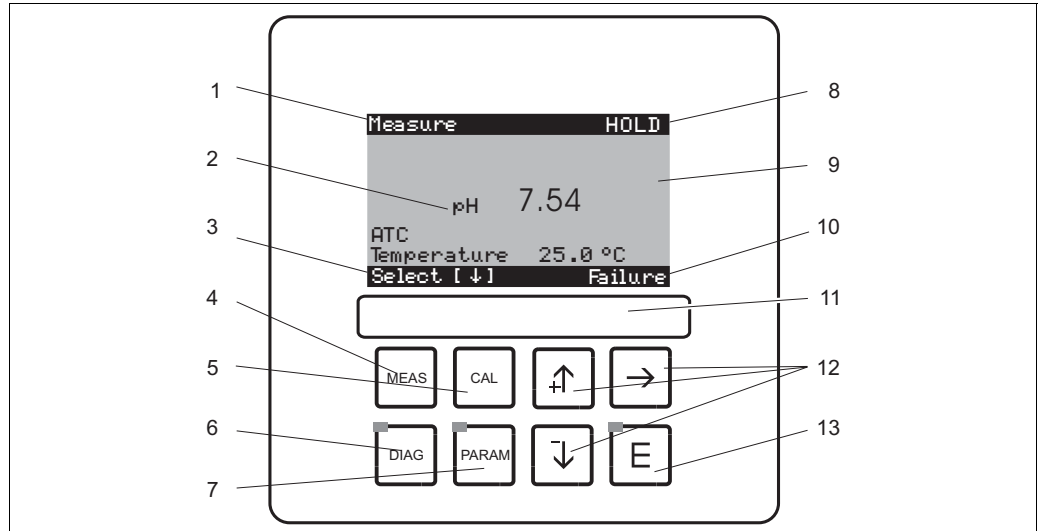

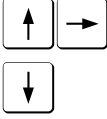

Fig. 51: Operating elements

- 1 Current menu
- 2 Current parameter
- 3 Navigation row: Arrows for scrolling; **E** for scrolling on; notice for canceling
- 4 Measuring mode key
- 5 Calibration key
- 6 Diagnosis menu key
- 7 Configuration menu key
- 8 HOLD displayed if HOLD active
- 9 Current main measured value
- 10 "Failure", "Warning" displayed if the NAMUR contacts are triggered
- 11 Labeling field
- 12 Arrow keys for selecting and entering
- 13 Enter key



6.1.2 Function of keys

	"PARAM" takes you to the configuration menu. Note! "PARAM" allows you to return to the previous "return field" from any point in the menu. These are marked in bold in the overview of the menu.
	"DIAG" takes you to the menu for device diagnosis.
	"MEAS" switches to Measuring mode. This displays the measured values. Use the arrow keys to scroll through the various measured value readings. Note! Press "MEAS" to exit any of the "PARAM", "DIAG", "CAL" menus without terminating the settings / calibration.

	<p>"CAL" takes you to the calibration menu to calibrate sensors.</p>
	<p>With the "Enter" key, you proceed one step further in the menu or you confirm the option selected.</p> <p>LED lit Green: Everything OK Red: An error has occurred</p>
	<ul style="list-style-type: none"> ■ You can use the arrow keys to scroll through the menu items and select the option you require (if a choice is possible). ■ Increase/decrease numbers by one level with "+" / "-". Go to the next number with the "right arrow" (editor type 1) or ■ ""Activate" with the "right arrow" and scroll through the option with "+" / "-" (editor type 2) (see the "Menu editor types" section on the editor types)

6.1.3 Service switch

The service switch is located on the housing front of the control unit. Two switching positions are available:

	<p>Service/Off: (horizontal switch setting)</p> <ul style="list-style-type: none"> ■ The sensor moves into the rinse chamber. ■ "Hold" is active for the outputs.
	<p>Measure/On: (vertical switch setting)</p> <p>After moving out of the Service position, you are asked whether a program should be started or whether the sensor should be moved into the process without cleaning.</p> <p>Only those programs are offered which have already been edited.</p>



Note!

The service switch always has priority (Emergency Stop function). This means that any program running is aborted as soon as the service switch is switched.

6.1.4 Measured value display

Various measured value displays are available. Use the arrow keys to scroll between the different menus. Switch between the current measured value curve and the data logger with the Enter key .

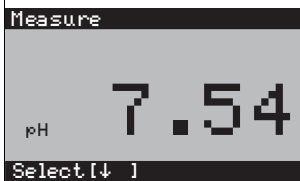
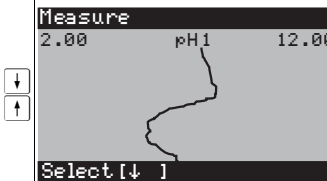
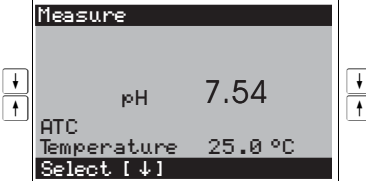
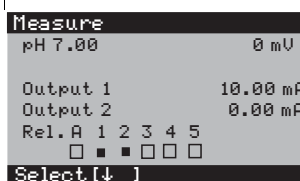
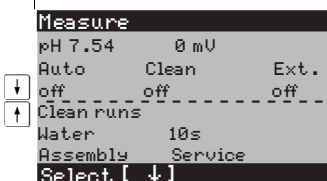
 <p style="text-align: right; font-size: small;">a0004131-en</p>	 <p style="text-align: right; font-size: small;">a0004132-en</p>	 <p style="text-align: right; font-size: small;">a0004913-en</p>	<p>The current measured value is displayed.</p> <p>When you have activated the data logger, you can see the current measured value curve here (record mode). If you have activated both data loggers, press the arrow key to switch to the view of the second measured value characteristic.</p> <p>In this measured value display, you can see the measured value, the type of temperature compensation and the related temperature.</p>
 <p style="text-align: right; font-size: small;">a0004914-en</p>	 <p style="text-align: right; font-size: small;">a0004912-en</p>		<p>In this measured value display, you can see the current and voltage values as well as the contact status of the relays at a glance. Active relay = ■ (assigned a function)</p> <p>In this measured value display, you can see the measured value, the status of automatic, cleaning, external control and the status of the current cleaning program.</p>

6.1.5 Operation access authorization

Access codes

Functions can be protected by four-digit access codes to protect the transmitter against unintentional and undesired changes to the configuration and the calibration data. All the functions are freely accessible provided no codes have been defined.

The following levels of access authorization are available.

- **Read-only level** (can be accessed without a code)

The complete menu can be viewed. The configuration cannot be altered. No calibration is possible. On this level, only the control parameters for new processes can be changed in the "DIAG" menu branch.
- **Operator level** (can be protected by the service access code)

This code allows access to the calibration menu.
The temperature compensation menu item can be used with this code.
The factory functions and the internal data can be viewed.
Factory setting: Code = 0000, i.e. the levels are not protected.
In case you have mislaid/forgotten the supplied maintenance code, contact your service office for a universally valid maintenance code.
- **Specialist level** (can be protected by the specialist access code)

All menus can be accessed and changed.
Factory setting: Code = 0000, i.e. the levels are not protected.
In case you have mislaid/forgotten the supplied specialist code, contact your service office for a universally valid specialist code.

To activate the codes (= lock the functions), please refer to the menu item "PARAM > Set up 1 > Access codes". You can enter your desired codes here. If the code is activated, you can only edit the protected areas with the rights mentioned above.



Note!

- Note down the selected code as well as the universal code and keep it in a place where unauthorized persons do not have access to it.
- If you reset the code to "0000", all the levels are freely accessible again for editing. The codes can only be reset in the "Specialist" menu.

Locking configuration via the key pad

Locking operation

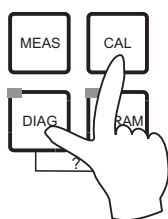

Press the **CAL** and **DIAG** keys simultaneously to lock the device onsite for configuration operations.
At the code prompt, the code appears as "9999". Only the settings in the "PARAM" menu can be seen.

Unlocking operation

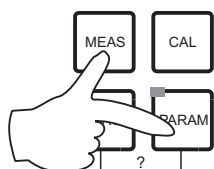

Press the **MEAS** and **PARAM** keys simultaneously to unlock operation.

6.1.6 Menu editor types

Depending on the type of setting, the functions for device configuration can be selected in two different ways.

Editor type E1

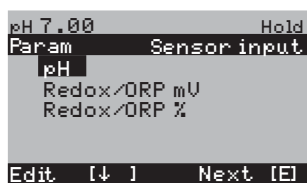

a0004154-en

For functions that can be selected directly from a specified range of options. "Edit" is displayed on the editing line.

- An option can be highlighted with the arrow keys.
- Confirm the option selected with **[E]** (=Enter).

Editor type E2

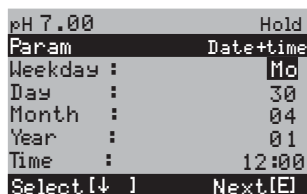

a0004155-en

For settings that have to be defined more specifically, e.g. weekday, time. "Select" is displayed on the editing line.

- An option can be highlighted with the arrow keys **[↑]** and **[↓]** (e.g. "Mon.").
- Activate the highlighted option with the right arrow key **[→]**. The highlighted option flashes.
- Scroll through the options (e.g. the weekdays) with the **[↑]** and **[↓]** arrow keys.
- Confirm the option selected with **[E]** (=Enter).
- If the desired option has been selected and confirmed with **[E]** (no flashing display), you can exit the menu item with **[E]**.

7 Commissioning

7.1 Points to note when commissioning digital sensors

pH sensors with Memosens technology save the calibration data. Consequently, the procedure for commissioning these sensors differs to that for standard electrodes.

Proceed as follows:

1. Install the transmitter and the assembly.
2. Connect the transmitter and the sensor cable.
3. Configure the transmitter for your specific requirements (see "System configuration" section).
4. Connect the sensor, precalibrated at the factory, with Memosens technology and immerse it into the medium or the buffer.
5. The sensor-specific calibration data saved are automatically transmitted to the transmitter.
6. The measured value is displayed.
Normally, you can accept this value without calibrating the sensor.
Calibration is only necessary in the following instances:
 - Where there are strict requirements in terms of accuracy
 - When the sensor has been in storage for more than 3 months
7. Check the transmission of the measured value to the process control system or to the switching unit.

7.2 Points to note when commissioning ISFET sensors

Switch-on behavior

A closed control loop is created once the measuring system is switched on. The measured value adjusts to the real value during this time (approx. 5 ... 8 minutes). This settling occurs every time the liquid film between the pH-sensitive semiconductor and the reference lead is interrupted (e.g. from dry storage or intensive cleaning with compressed air). The settling time in question depends on how long the interruption lasts.

Sensitivity to light

Like all other semiconductor components, the ISFET chip is sensitive to light (fluctuations in measured value). However, this only affects the measured value when light falls directly on the sensor. Therefore, avoid direct sunlight during calibration. Normal ambient light does not affect measurement.

7.3 Function check





Warning!

- Make sure there is no danger to the measuring point. Uncontrolled actuated pumps, valves or similar could lead to damage to instruments.
- Make sure that all the connections have been established correctly.
- Make sure the supply voltage matches the voltage indicated on the nameplate!

7.4 Switching on

Before first startup, make sure you understand how to operate the device. Please refer to the "Safety instructions" and "Operation" sections in particular.

We recommend the following procedure for commissioning:

1. Connect Mycom S CPM153 to the power supply .
2. Switch the service switch to the Service position .
3. Wait for CPM153 and the control unit to initialize.
Function of the green "Alive LED":
 - Frequency of approx. 2 pulses per second: Communication is active.
 - Frequency of approx. 1 pulse per second: Establishing communication.
 - LED lit constantly: No communication.
 If the LED is not lit, check the power supply for terminal L+/L- (12 ... 15 V DC).
4. Only initial commissioning:
Run the "Quick Setup" (see "Quick Setup" section).
5. Switch the service switch to the Measure position .
6. Configure parameters: Select a function for the additional valves (optional).
7. Start the quick-test program "User 3" and check the entire system for leaks.
Program start:
"PARAM > Specialist > Manual operation > Topcal > Status messages (Enter) > Start program > User 3".
8. Then configure the system completely via the software.

First commissioning

On first switch-on, the instrument starts automatically with the Quick Setup menu. This asks you about the most important instrument settings. After you close the menu, the instrument is ready for use and measurement in its standard configuration.



Note!



- You must completely run through the Quick Setup menu. If you do not, the instrument will not be operational. If you interrupt Quick Setup, it will start again the next time you start it up until **all** the items have been processed and completed.
- You have to enter the specialist access code (factory setting 0000) to configure.







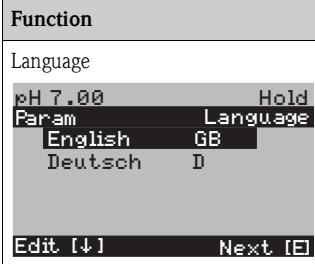

7.5 Quick Setup

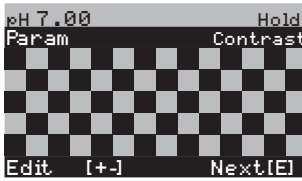

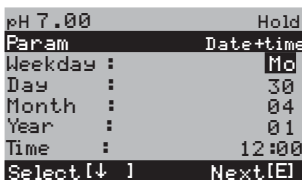
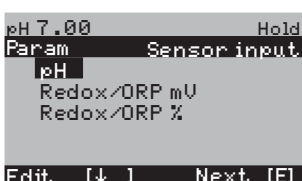
The Quick Setup menu allows you to configure the most important functions of the transmitter. It is started automatically during initial commissioning and can be called any time via the menu structure.

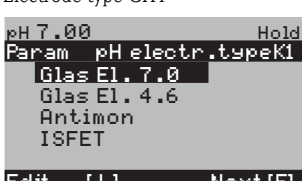
To call the menu, select:

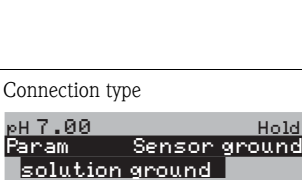
 > Specialist > Spec. access code: 0000 > First start up

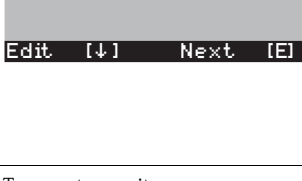
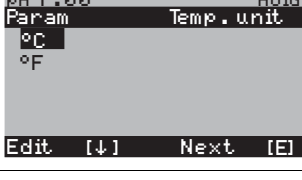
Function	Options	Info
	Options <ul style="list-style-type: none"> ■ English ■ Language ordered Factory setting English	 Note! ""Language ordered" refers to the language that you chose for your device by means of the order code ("Language version"). All the other settings remain if the other language is selected.

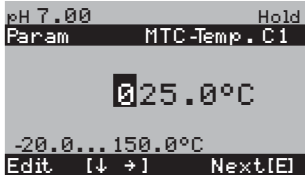
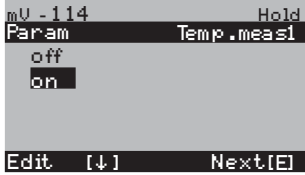
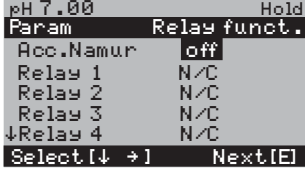
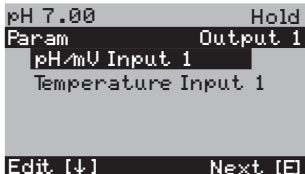
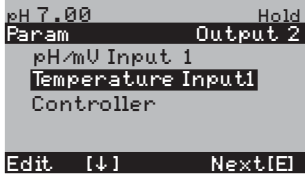
Function	Options	Info
Contrast 		Contrast setting where applicable You can increase or reduce the contrast of the display with the arrow keys  and  .
Date + time 	Weekday Day Month Year Time	Enter the complete date and time here. These data are used for the logbooks and the automatic cleaning system.
Mode 	Options <ul style="list-style-type: none"> ■ pH ■ Redox mV ■ Redox % Factory setting pH	 Note! <ul style="list-style-type: none"> ■ If you change the operating mode, all the user settings are automatically reset. If you want to save your settings, use a DAT module. ■ The Redox/ORP:% mode is not available for redox sensors with Memosens technology where the SW version is ≤ 2.01.00.
Electrode type CH1 	Options <ul style="list-style-type: none"> ■ Glass el. 7.0 ■ Glass el. 4.6 ■ Antimony ■ ISFET Factory setting Glass 7.0	Specify the sensor that is used (only pH).  Note! <ul style="list-style-type: none"> ■ The type of electrode does not have to be selected for digital sensors. ■ The temperature sensor defaults to Pt 1000 when you change from a glass or antimony electrode to ISFET. Pt 100 is selected when the situation is the reverse. ■ In the glass/ISFET version, Mycom S is supplied for measuring with glass electrodes as standard.
Connection type 	Options <ul style="list-style-type: none"> ■ Solution ground ■ No solution ground Factory setting Solution ground	Specify whether you are measuring symmetrically (=with PML) or unsymmetrically (=without PML).  Note! <ul style="list-style-type: none"> ■ This selection is not displayed for digital sensors with Memosens technology. A symmetrically high-resistance connection is not required for digital data transmission. ■ More information on symmetrical and unsymmetrical measurement is provided on the CD-ROM.
Temperature unit 	Options <ul style="list-style-type: none"> ■ °C ■ °F Factory setting °C	
Temperature compensation, temp.sensor input 1 	Options <ul style="list-style-type: none"> ■ ATC C1 ■ MTC ■ MTC+Temp Factory setting ATC C1	Only for pH measurement: ATC: Automatic temperature compensation using temperature sensor MTC: Temperature compensation with manual input MTC+temp: Temperature compensation with temperature entered manually. The temperature measured with a temperature sensor is displayed, however

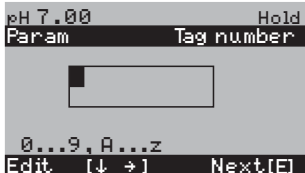
Function	Options	Info
<p>MTC temperature, temp. sensor input 1</p> 	<p>-20.0 ... 150.0 °C</p> <p>Factory setting 25.0 °C</p>	<p>Only available with pH and MTC or MTC+Temp selected in the previous field.</p>
<p>Temperature measurement</p> 	<p>Options</p> <ul style="list-style-type: none"> ■ Off ■ On <p>Factory setting On</p>	<p>Only available with redox measurement.</p>
<p>Contact functions</p> 	<p>Activation and subsequent entry</p> <ul style="list-style-type: none"> ■ NAMUR <ul style="list-style-type: none"> - On - Off ■ Relay 1-5 <ul style="list-style-type: none"> - N/C - Controller - Limit - CCW - CCC <p>Factory setting NAMUR: Off Relay 1-5: N/C</p>	<p>You can specify the function of the five relays here.</p> <p>When you switch on NAMUR, relays 1 and 2 are assigned and are not available for another function (see "Namur assignment" section).</p> <p>Controller: Relay contact for controller output Limit: Limit switch function CCW: Chemoclean water. Supply of water for the Chemoclean function. CCC: Chemoclean cleaner. Supply of cleaner for the Chemoclean function. (Together, CCC and CCW form the "Chemoclean" function; information on Chemoclean is provided in the "Set up 2 - Chemoclean" section.)</p>
<p>Current output 1, output variable</p> 	<p>Options</p> <ul style="list-style-type: none"> ■ pH/mV Input 1 ■ Temperature Input 1 <p>Factory setting pH/mV Input 1</p>	<p>Select the measured value to be output at current output 1.</p>
<p>Current output 2, output variable</p> 	<p>Options</p> <ul style="list-style-type: none"> ■ pH/mV Input 1 ■ Temperature Input 1 ■ Continuous controller <p>Factory setting Temperature Input 1</p>	<p>Select the measured value to be output at current output 2.</p> <p>Continuous controller: The controller manipulated variable is output via the current output (see also Controller menu).</p> <p> Note! Danger of data loss. If you change the assignment for the current output from "continuous controller" to another function once you have configured the controller, the entire controller configuration is reset to the default values.</p>
<p>Tag number</p> 	<p>0 ... 9; A ... Z</p>	<p>Enter your client-specific device number here (32-digit tag number): This is also saved on the DAT module which is available as an option.</p>







Function	Options	Info
<p>Exit Quick Setup</p> <pre>pH 7.00 Hold Param Start up end restart Edit [↓] Next [E]</pre>	<p>Options</p> <ul style="list-style-type: none"> ■ end ■ restart <p>Factory setting end</p>	Specify whether you want to save the settings and exit the Quick Setup menu or run through the menu again to make corrections.

7.5.1 Configuring Clean program

The following example illustrates how to configure the Clean cleaning program for your Topcal. All the cleaning functions and the cleaning and calibration programs are described in the "Set up 2 - Topcal S" section.

To call the menu, select:

 > Specialist > Set up 2 > Topcal > Config. Topcal

Display	Entry
<pre>pH 7.00 Hold Param Status Automatic off Clean trigger off Ext. control off Next [E]</pre>	The current status of the cleaning functions is displayed. Press  to continue.
<pre>pH 7.00 Hold Param Name: V1 Valve 1 0...9; A...Z Edit [↓↔] Next [E]</pre>	Press  to continue.
<pre>pH 7.00 Hold Param Set up menu Automatic Cleaning Purfail prog. Prog. editor Edit [↓] Next [E]</pre>	Select "Prog. editor" and confirm with  .
<pre>pH 7.00 Hold Param Prog. editor Clean Clean C Clean S Clean CS ↓ User 1 Edit [↓] Next [E]</pre>	Select "Clean" and confirm with  .
<pre>pH 7.00 Hold Param Clean Insert progr. Edit Set up Progr. time Change name Edit [↓] Next [E]</pre>	Select "Setup" to configure the program steps. Confirm with  .
<pre>pH 7.00 Hold Param Clean 01 Assembly service 02 Water 60s 03 Cleaner 3s 04 Wait 120s ↓ 05 Water 60s Select [↓] EditLine [E]</pre>	Use the arrows to select the program step you wish to adjust, e.g. Water. Press  to edit.

Display	Entry
<pre> pH 7.00 Hold Param Time Water 0040s 0...9999s Edit [↓→] Next [E] </pre>	<p>Use the arrows to set the required conveying time for water. Press [E] to get back to selecting the program steps.</p>
<pre> pH 7.00 Hold Param Clean 01 Assembly service 02 Water 60s 03 Cleaner 3s 04 Wait 120s ↓ 05 Water 60s Select [↓] EditLine [E] </pre>	<p>Where necessary, adjust the other program steps. The program time is calculated automatically. Once you have finished configuring, press [MEAS] to go back to the measuring mode.</p>
<pre> pH 7.00 Hold Param Manual operat. Hold Topcal </pre> <p>Edit [↓] Next [E]</p>	<p>To start the program, press [PARAM] and select "Manual operation > Topcal". Confirm with [E].</p>
<pre> pH 7.00 Hold Param Status Automatic off Clean trigger off Ext. control off </pre> <p>Next [E]</p>	<p>The current status of the cleaning functions is displayed. Press [E] to continue.</p>
<pre> pH 7.00 Hold Param Topcal Retract assembly Start program Stop program </pre> <p>Edit [↓] Next [E]</p>	<p>Select "Start program". Confirm with [E].</p>
<pre> pH 7.00 Hold Param Program no prog. Clean Clean C Clean S ↓ Clean CS Edit [↓] Next [E] </pre>	<p>Select "Clean". Confirm with [E]. The program is started.</p>

7.6 Device configuration





7.6.1 Set up 1 - Sensor input

Use this menu item to change the settings for measured value acquisition such as the operating mode, the measuring principle, the type of electrode etc.

Apart from measured value damping, you have already made all the settings for this menu during initial commissioning with the Quick Setup menu. You can change the selected values in this menu.

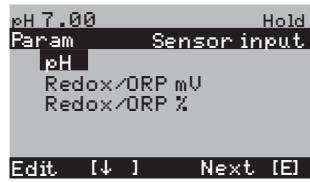
You have to enter your specialist access code to access the configuration menu.





To call up the menu, select: "PARAM" > Specialist > Set up 1 > Sensor input".

Function	Options	Info
Operating mode 	Options <ul style="list-style-type: none"> ■ pH ■ Redox/ORP mV ■ Redox/ORP % Factory setting pH	 Note! <ul style="list-style-type: none"> ■ If you change the operating mode, all the user settings are automatically reset. If you want to save your settings, use the DAT module. ■ The Redox/ORP:% mode is not available for redox sensors with Memosens technology where the SW version is ≤ 2.01.00.
Electrode type CH1	Options <ul style="list-style-type: none"> ■ Glass el. 7.0 ■ Glass el. 4.6 ■ Antimony ■ ISFET Factory setting Glass 7.0	Specify the sensor that is used (only pH).  Note! <ul style="list-style-type: none"> ■ The type of electrode does not have to be selected for digital sensors. ■ The temperature sensor defaults to Pt 1000 when you change from a glass or antimony electrode to ISFET. Pt 100 is selected when the situation is the reverse. ■ In the glass/ISFET version, Topcal S is supplied for measuring with glass electrodes as standard.
Connection type	Options <ul style="list-style-type: none"> ■ Solution ground ■ No solution ground Factory setting Solution ground	Specify whether you are measuring symmetrically (=solution ground) or unsymmetrically (=no solution ground).  Note! <ul style="list-style-type: none"> ■ The type of connection does not have to be selected for digital sensors with Memosens technology. A symmetrically high-resistance connection is not required for digital data transmission. ■ More information on symmetrical and unsymmetrical measurement is provided on the CD-ROM.
Measured value damping	Activation and subsequent entry <ul style="list-style-type: none"> ■ pH/ORP 00 ... 30 s ■ Temperature 00 ... 30 s Factory setting 00s	The mean value over the set time is displayed. 00s = no attenuation

7.6.2 Set up 1 - Display

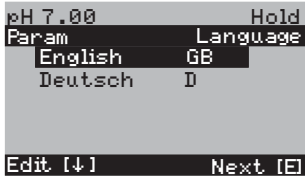
To call the menu, select:

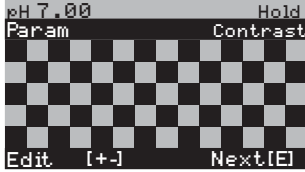
" > Specialist > Set up 1 > Display"

Function	Options	Info
<p>Language</p> 	<p>Options</p> <ul style="list-style-type: none"> ■ English ■ Language ordered <p>Factory setting English</p>	<p> Note!</p> <p>""Language ordered" refers to the language that you chose for your device by means of the order code ("Language version").</p> <p>All the other settings remain if the other language is selected.</p>
<p>Contrast</p> 		<p>Contrast setting where applicable</p> <p>You can increase or reduce the contrast of the display with the arrow keys  and .</p>
<p>Date + time</p>	<p>Weekday Day Month Year Time</p>	<p>Enter the complete date and time here. These data are used for the logbooks and the automatic cleaning system.</p>
<p>Number of decimal places</p>	<p>Options</p> <ul style="list-style-type: none"> ■ pH 00.00 ■ pH 00.0 <p>Factory setting pH 00.00</p>	<p>Only available for pH operating mode: Specify whether the measured values are to be displayed to one or two decimal places.</p>
<p>Temperature unit</p>	<p>Options</p> <ul style="list-style-type: none"> ■ °C ■ °F <p>Factory setting °C</p>	
<p>Tag number</p>	<p>0 ... 9; A ... Z</p>	<p>Enter your client-specific device number here (32-digit tag number): This is also saved on the DAT module which is available as an option.</p>

7.6.3 Set up 1 - Access codes

To call the menu, select:

" > Specialist > Set up 1 > Access codes"

Function	Options	Info
<p>Service code</p> 	<p>0000 ... 9997</p> <p>Factory setting 0000</p>	<p>Enter the operator access code. This code allows access to the calibration menu and the temperature compensation menu item.</p> <p>0000 = No locking</p>
<p>Specialist code</p>	<p>0000 ... 9997</p> <p>Factory setting 0000</p>	<p>Enter the specialist code. This code allows access to all the menu items.</p> <p>0000 = No locking</p>



Note!

Danger of misuse





Make sure that the codes you entered and the general universal codes are protected against misuse by unauthorized persons. Note down the codes and keep them in a place where unauthorized persons do not have access to them (see also the "Access authorization - operation" section).

7.6.4 Set up 1 - Current outputs

The transmitter is fitted with two current outputs.

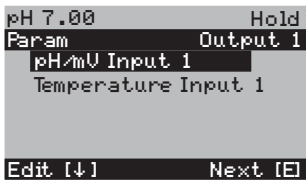
To call the menu, select:

 > Specialist > Set up 1 > Current output





Function	Options	Info
Current output	Options <ul style="list-style-type: none"> ■ Current output 1 ■ Current output 2 	Select the current output you want to configure.
Current output 1 (or 2)		
Output variable 	Options <ul style="list-style-type: none"> ■ pH/mV Input 1 ■ Temperature Input 1 ■ Continuous controller (only current output 2) Factory setting Current output 1: pH/mV input 1 Current output 2: Temperature input 1	Select the measured value to be output at the current output. Continuous controller: The controller manipulated variable is output via the current output (see also Controller menu).  Note! Danger of data loss. If you change the assignment for the current output from "continuous controller" to another function once you have configured the controller, the entire controller configuration is reset to the default values.
Note	Caution! The configuration is changed.	Notice on the display if the setting of the current outputs changes. Press  to confirm the change. Press  to cancel the change.
Output range	Options <ul style="list-style-type: none"> ■ 0 ... 20mA ■ 4 ... 20 mA Factory setting 4 ... 20 mA	Select the current range for the current outputs.
Note	Caution! Current output 0 ... 20mA and error current = 2.4 mA is critical.	Error current is in the measured current range if "0...20 mA" is selected for current range and "Min" is selected under Alarm in the "Alarm output" field (see Set up 1 - Alarm). Recommended combinations: <ul style="list-style-type: none"> ■ Current range 0...20 mA and error current max (22 mA) ■ Current range 4...20 mA and error current min (2.4 mA)
Output type	Options <ul style="list-style-type: none"> ■ Linear ■ Table Factory setting Linear	Linear: The curve is linear from the lower to the upper value. Table: If the current output curve should not be linear, a customized pattern can be entered via a table with up to 10 value pairs. Exact adaptation to the nonlinear medium behavior can achieve a higher level of accuracy.

Function	Options	Info
Linear		
Measured value limits	Activation and subsequent entry <ul style="list-style-type: none"> ■ 0/4 mA -02.00 ... 16.00 pH -50 ... 150 °C -0500 ... 0500 mV ■ 20 mA -02.00 ... 16.00 pH -50 ... 150 °C -0500 mV ... 0500 mV Factory setting 0/4 mA: 02.00 pH / 000.0 °C / -0500 mV 20 mA: 12.00 pH / 100.0 °C / 0500 mV	Enter the upper and lower measured value limit. The minimum distance between the upper and lower measured value limit is 2 pH units (e.g. 0/4 mA: pH 7 and 20 mA: pH 9)
Note	Linear active.	The linear curve is active after confirming with <input type="button" value="E"/> . Cancel with <input type="button" value="PARAM"/> .
Table		
Total pairs	01 ... 10	Specify the number of value pairs (table points) for your table.
Table	Activation and subsequent entry <ul style="list-style-type: none"> ■ pH/redox/temperature -02.00 ... 16.00 pH -0500 ... 0500 mV -50 ... 150 °C ■ mA 0.00 ... 20.00 mA 	Enter the necessary value pairs. The number of value pairs corresponds to the value entered in the previous field. Example of value pairs with four table points:
		<p style="text-align: right; font-size: small;">a0004223</p>
Confirm	Options <ul style="list-style-type: none"> ■ OK ■ Delete element Factory setting OK	Are the value pairs OK or do you want to delete elements? Delete: In the screen that follows, select the row to be deleted, delete with <input type="button" value="→"/> and confirm with <input type="button" value="E"/> .
Table status notice	Valid table	Status of table. If invalid, then back to the previous field.
Activate	Table active	The table is active after confirming with <input type="button" value="E"/> . Cancel with <input type="button" value="PARAM"/> .

7.6.5 Set up 1 - Relays

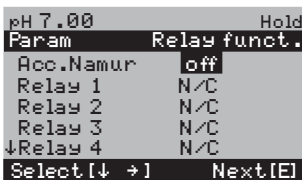
To call the menu, select:

 > Specialist > Set up 1 > Relays

Function	Options	Info
Contact functions 	Activation and subsequent entry <ul style="list-style-type: none"> ■ NAMUR <ul style="list-style-type: none"> - On - Off ■ Relay 1-5 <ul style="list-style-type: none"> - N/C - Controller - Limit - CCW - CCC Factory setting NAMUR: Off Relay 1-5: N/C	You can specify the function of the five relays here. When you switch on NAMUR, relays 1 and 2 are assigned and are not available for another function (see "Namur assignment" section). Controller: Relay contact for controller output The controller relays are configured in the "  > Set up 2 > Controller settings" menu. Limit: Limit switch function The limit contacts are configured in the "  > Set up 2 > Limit switch" menu. CCW: Chemoclean water. Supply of water for the Chemoclean function. CCC: Chemoclean cleaner. Supply of cleaner for the Chemoclean function. (Together, CCC and CCW form the "Chemoclean" function; information on Chemoclean is provided in the "Set up 2 - Chemoclean" section.)  Note! <ul style="list-style-type: none"> ■ Danger of data loss. If the controller is already completely configured for outputting via relays and you reduce the number of relays assigned to the controller, the entire controller configuration is reset to the default values. ■ If you change the relay assignment for the controllers here, you have to reassign a relay for all the functions selected in the relay menu. Example: Relays 4 and 5 are assigned for the controller and you change the assignment for the controller to relays 5 and 6 (the number of relays remains at 2) (no loss of data as long as the number of relays assigned is not reduced!). ■ You can only activate NAMUR if the required relays 1 and 2 are free.
Namur contacts	Options <ul style="list-style-type: none"> ■ Active open (NC contact) ■ Active closed (NO contact) Factory setting Active closed (NO contact)	Only available if NAMUR is activated: Select the assignment of the NAMUR contacts as an NC contact (contact open if relay is active) or an NO contact (contact closed if relay is active). If the NAMUR function is enabled, the Alarm, Relay 1 and Relay 2 contacts are given the following functions: <ul style="list-style-type: none"> ■ "Failure" = Fault-signaling contact (terminals 41/42): Failure errors are active if the measuring system no longer works properly or if process parameters have reached a critical value. ■ "Maintenance needed" = Relay 1 (terminals 47/48): Warning messages are active if the measuring system is still working properly but should be serviced or a process parameter has reached a value that requires intervention on the part of the operator. ■ "Function check" = Relay 2 (terminals 57/58): This contact is active during calibration, maintenance, configuration and during the automatic cleaning/calibration cycle.

Function	Options	Info
Controller contacts	Options <ul style="list-style-type: none"> ■ Active open (NC contact) ■ Active closed (NO contact) Factory setting Active closed (NO contact)	Only available if the controller has been selected as a relay function: Select the assignment of the controller contacts as "Active open" or "Active closed".
Limit contacts	Options <ul style="list-style-type: none"> ■ Active open (NC contact) ■ Active closed (NO contact) Factory setting NO contact	Only available if the limit switch has been selected as a relay function: Select the assignment of the limit contacts as "Active open" or "Active closed".
Fault-signaling contact contact type	Options <ul style="list-style-type: none"> ■ Active on ■ Active pulse Factory setting Active on	Only for NAMUR function = Off: Active on: Contact is active as long as the error is present. Active pulse: Contact is active for 1 second when the alarm signal occurs.
Chemoclean notice	Chemoclean is always an NO contact.	Only available if the complete Chemoclean function (CCC and CCW) is selected in the first field of the contact configuration: In the Chemoclean function, the valves of the CYR10 injector are actuated with an NO contact.

7.6.6 Set up 1 - Temperature

The pH value requires temperature compensation for two reasons:

1. Temperature effect of the electrode:
The slope of the electrode depends on the temperature. Thus, this effect must be compensated in the event of changes in temperature (temperature compensation, see below).
2. Temperature effect of the medium:
The medium pH value is also temperature dependent. For high-precision measurement, the pH value can be entered in tabular form as a function of the temperature (medium temperature compensation, see below).

Temperature compensation

- **ATC:** Automatic temperature compensation: The medium temperature is measured with a temperature sensor. By means of the temperature input in Mycom S CPM153, this temperature is used to adapt the slope of the electrode to the medium temperature.
- **MTC:** Manual temperature compensation: This is useful in processes that run at constant temperatures. Enter the temperature value manually here to adapt the slope of the electrode to the medium temperature.
- **MTC+Temp.:** The pH value is corrected with the temperature manually entered. On the display however, the value which appears is what the temperature sensor measures in the medium.

Medium temperature compensation

Tables can be created in CPM153 for three different media for medium temperature compensation. Before starting the process, the most suitable table for the active medium can be selected.



Procedure:



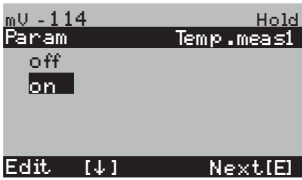

- Take a sample from the process. The pH value should be as close as possible to the set point of the process.
- In the laboratory, heat the sample to at least the process temperature.
- During the cooling phase, record the value pairs for pH and temperature at the temperatures at which measurement should later take place (e.g. process temperature and ambient temperature in the laboratory).
- Enter these recorded value pairs in the table ("Enter value pairs" field). As the reference temperature ("Enter reference temperature" field), select the temperature at which the set point of the process is defined (e.g. ambient temperature in the laboratory).

Temperature compensation menu

To call the menu, select:

"PARAM" > Specialist > Set up 1 > Temperature"

Function	Options	Info
Temperature measurement 	Options <ul style="list-style-type: none"> ■ Off ■ On Factory setting On	Only available with redox measurement
Select temperature compensation 	Options <ul style="list-style-type: none"> ■ Temp. comp. sensor ■ Temp. comp. process (only for pH operating mode) Factory setting Temperature	Only available with pH measurement Select the temperature compensation necessary. Temperature compensation sensor: Automatic (ATC) or manual (MTC) temperature compensation Temperature compensation process: Compensation of the medium temperature using customer-specific tables (see below)
Temperature		
Temperature compensation	Options <ul style="list-style-type: none"> ■ ATC C1 ■ MTC ■ MTC+Temp Factory setting ATC C1	Only for pH measurement: ATC: Automatic temperature compensation using temperature sensor MTC: Temperature compensation with manual input MTC+temp: Temperature compensation with temperature entered manually. The temperature measured with a temperature sensor is displayed, however  Note! The type of temperature compensation selected here is active during measuring operation. For the calibration, you must configure the desired compensation in the "Calibration" menu.
MTC temperature	-20.0 ... 150.0 °C Factory setting 25.0 °C	Only available with pH and MTC or MTC+Temp selected in the previous field.
Temperature sensor	Options <ul style="list-style-type: none"> ■ Pt100 ■ Pt1000 ■ NTC 30K Factory setting Pt100	Select the temperature sensor to suit your sensor
Temperature actual value	-5.00 ... +5.00 °C Factory setting 0.00 °C	You can change/adjust the value currently measured with the temperature sensor. The temperature difference is stored internally as an offset value.
Offset value	-5.0 ... +5.0 °C	You can edit or reset the offset value resulting from the previous field here.
Temperature compensation process		
Select compensation	Options <ul style="list-style-type: none"> ■ Select temp. table ■ Edit table ■ Reference temperature Factory setting Select temp. table	Select temp. table You activate an existing table. Create table: You create a specific table to suit your requirements. Reference temperature: You enter a temperature to which your measured values refer.

Function	Options	Info
Select table		
Medium	Options <ul style="list-style-type: none"> ■ Medium 1 ■ Medium 2 ■ Medium 3 ■ Off Factory setting Off	Select a medium. Off: No medium compensation
Edit table		
Medium for compensation curve	Options <ul style="list-style-type: none"> ■ Medium 1 ■ Medium 2 ■ Medium 3 Factory setting Medium 1	Select a medium. You can enter compensation curves in the form of tables for three different media.
Number of points	02 ... 10 Factory setting 02	Specify the number of table points (value pairs) for the table.
Pairs	Activation and subsequent entry <ul style="list-style-type: none"> ■ °C -20 ... 150 °C ■ pH -2.00 ... 16.00 pH 	Enter the temperature and the related pH/redox values of your medium (number of required value pairs = number of table points specified in the previous field).
Confirm	Options <ul style="list-style-type: none"> ■ OK ■ Delete element(s) 	Are the value pairs OK or do you want to delete elements? Delete: In the screen that follows, select the row to be deleted, delete with  and confirm with  .
Table status notice	Valid table	The table is active after confirming with  . Cancel with  .
Reference temperature		
Reference temperature	-20 ... 150 °C Factory setting 25 °C	Enter the temperature to which the medium should be temperature-compensated. Here, enter the temperature at which the pH set point of the process is defined (e.g. the ambient temperature in the laboratory).

7.6.7 Set up 1 - Alarm

The transmitter constantly monitors the most important functions. When an error occurs, an error message is set that can trigger one of the following actions:

- The fault-signaling contact is made active
- Current output 1 and 2 output the set error current (2.4 or 22 mA). Exception: If you selected the "Continuous controller" function for current output 2 (see "Set up 1 - Current output" section), this output does not output an error current.
- Chemoclean cleaning is started.

In the list of error messages in the Troubleshooting section, you can see how the error numbers are assigned as per the factory setting. However, in the "ALARM" menu, you have the option of outputting the error messages individually at the alarm relay, the current output or as a start of cleaning.

Alarm menu

To call the menu, select:

"PARAM" > Specialist > Set up 1 > Alarm"

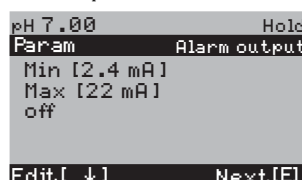
Function	Options	Info
Alarm output 	Options <ul style="list-style-type: none"> ■ Min (2.4mA) ■ Max (22 mA) ■ Off Factory setting Max (22 mA)	Set the error current at which an error message is active.
Note	Caution! Current output 0 ... 20mA and error current = 2.4 mA is critical.	The error current is in the measured current range if the current range selected is "0 ... 20 mA" and "Min" was selected in the previous field. Recommended combinations: <ul style="list-style-type: none"> ■ Current range 0...20 mA and error current max (22 mA) ■ Current range 4...20 mA and error current min (2.4 mA)
Alarm delay	0 ... 2000 s Factory setting 0 s	Specify the delay time from when the error occurs to when the alarm is triggered.
Error/contact assignment	Activation and subsequent entry <ul style="list-style-type: none"> ■ R (alarm relay) <ul style="list-style-type: none"> - On - Off ■ I (error current) <ul style="list-style-type: none"> - On - Off ■ CC (Chemoclean) <ul style="list-style-type: none"> - On - Off 	The function the error triggers can be individually assigned to each error: R: Assignment to alarm relay. An activated error triggers an alarm. I: This error triggers an error current. CC: Chemoclean. This error triggers a cleaning.
Dose-time alarm	Activation and subsequent entry <ul style="list-style-type: none"> ■ Function <ul style="list-style-type: none"> - On - Off ■ Time <ul style="list-style-type: none"> 2 ... 9999 s Factory setting Function: Off Time: 2 s	Activate or deactivate the alarm if the dosage time is overshoot. Time: Enter the maximum dosing time permitted. An alarm is output once this time elapses.

7.6.8 Set up 1 - Hold

The current outputs can be "frozen" for each menu. This means that the value which you define in this menu is output. With hold, "Hold" appears in the display. This function can also be activated externally by means of the hold input (see the "Connecting external inputs" section). The onsite hold has a higher priority than an external hold.





Note!

- If Topcal S is activated as the hold source, hold is active as soon as the assembly goes to the Service position.
- If a hold is active, no new automatic programs are started. They can be started externally or via local operation where necessary.
- You can deactivate Topcal S as the hold source (PARAM > Set up 1 > Hold > CPC off).
- If current output 2 is configured for the controller, it obeys the controller hold (see the last field in the table).

Hold menu

To call the menu, select:

"PARAM" > Specialist > Set up 1 > Hold"

Function	Options	Info
<p>Activate hold</p> 	<p>Activation and subsequent selection</p> <ul style="list-style-type: none"> ■ CAL <ul style="list-style-type: none"> - On - Off ■ DIAG <ul style="list-style-type: none"> - On - Off ■ PARAM <ul style="list-style-type: none"> - On - Off ■ CPC <ul style="list-style-type: none"> - On - Off <p>Factory setting On</p>	<p>Specify the menus for which the automatic hold should be activated.</p> <p>CAL: Calibration DIAG: Service/diagnosis PARAM: Configuration menu CPC on: Hold is active if the assembly is in the Service position.</p>
<p>Hold current</p>	<p>Options</p> <ul style="list-style-type: none"> ■ Last ■ Fixed ■ Min (0/4 mA) ■ Max (22 mA) <p>Factory setting Last</p>	<p>Specify which current value should be output in the event of a hold.</p> <p>Last: The current value is "frozen". Fixed The value specified in the following field is output in the event of a hold. Min / Max: The minimum or maximum current value is output.</p>
<p>Hold output</p>	<p>0 ... 100%</p> <p>Factory setting 0 %</p>	<p>Only available if "Fixed" was selected in the previous field: Specify the hold current. The value can be set between 0 % = 0/4 mA and 100 % = 20 mA</p>
<p>Hold time</p>	<p>0 ... 999 s</p> <p>Factory setting 010 s</p>	<p>The hold remains active during the hold dwell period entered once the CAL, PARAM, DIAG menus have been exited. During the hold delay time, the "Hold" indicator flashes in the display.</p>
<p>Controller hold</p>	<p>Options</p> <p>Freeze y (manipulated variable)</p> <ul style="list-style-type: none"> ■ On ■ Off <p>Factory setting Off</p>	<p>Specify whether the manipulated variable (dosing) should be frozen during a hold.</p> <p>On: The last manipulated variable is output during an active hold. Off: Dosing does not take place during a hold. PWM or PFM relays remain in the dropped-out state. An actuator drive is controlled until it is closed.</p> <p> Note! The controller remains active if the manipulated variable is output via an actuator with feedback. It also reacts in a hold in the event of a sudden change of position.</p>







7.6.9 Set up 1 - Calibration



pH operating mode



To call the menu, select:

" > Specialist > Set up 1 > Calibration"

Function	Options	Info
Calibration	Options <ul style="list-style-type: none"> ■ Offset ■ Onsite calibration type ■ Special buffer ■ Cal settings ■ Calibration timer ■ Autocal. Topcal Factory setting Offset	Select the initial settings for the calibration. Offset: Enter a fixed value by which the pH value is shifted. Manual calibration: Make initial settings for the function of the CAL key. Spec. buffer table: Edit tables for the special buffer. Cal settings: General calibration settings Calibration timer: Timer for calibration intervals Autocal. Topcal: Make initial settings for the Topcal S method of calibration.
Offset		
Enter offset	Activation and subsequent entry <ul style="list-style-type: none"> ■ Act. PV 1/2 -2.00 ... 16.00 pH ■ Offset 1/2 -2.00 ... 2.00 pH Factory setting Offset: 0.00 pH	Act. PV: The current measured value (primary value) with an offset is displayed and can be edited. Offset: The pH value difference between the measured value and the displayed value is displayed and can be edited. If you start operation with a set offset value, "OFFSET" is shown on the top right of the display.
Onsite calibration type		
Calibration parameters	Options <ul style="list-style-type: none"> ■ Data entry ■ Buffer manual ■ Fixed buffer ■ Auto. buffer recognition Factory setting Fixed buffer	Specify the type of calibration with which calibration takes place when the "CAL" button is pressed. Data input Enter the zero point and slope of the sensor. Manual buffer: Enter the value of the buffer for the calibration process. Buffer table: This function can be selected if the same buffer values are constantly used. Auto. Buffer recognition: The Mycom S transmitter automatically recognizes the buffer values used.
Buffer type	Options <ul style="list-style-type: none"> ■ DIN 19267 ■ E+H ■ NBS / DIN 19266 ■ Merck+Riedel ■ Special buffer Factory setting E+H	Only available for "Buffer table" and "Auto. buffer recognition": Select the buffer type for local calibration. Spec. buffer table: The tables for special buffer, which are to be defined in the "Special buffer" option, are used.  Note! The buffer tables for the buffer types on offer are provided in the appendix
Buffer 1	Options <ul style="list-style-type: none"> ■ Buffer 2.0 ■ Buffer 4.01 ■ Buffer 6.98 ■ Buffer 9.18 ■ Buffer 10.90 (option depends on the buffer type) Factory setting Buffer 6.98	Only available for buffer table: Select the pH value for buffer 1 of the two-point calibration.

Function	Options	Info
Buffer 2	Options <ul style="list-style-type: none"> ■ Buffer 2.0 ■ Buffer 4.01 ■ Buffer 9.18 ■ Buffer 10.90 (option depends on the buffer type) Factory setting Buffer 4.01	Only available for buffer table: Select the pH value for buffer 2 of the two-point calibration.
Special buffer		
Number of buffer	2 ... 3 Factory setting 2	Enter the desired number of buffers. A minimum of 2 and a maximum of 3 user-specific buffers can be saved with a table.  Note! The following four fields must be run through individually for every buffer.
Select buffer	1 ... 3 Factory setting 1	Select one of the buffer tables for editing.
Number of points	2 ... 10 Factory setting 10	Specify the desired number of table points (value pairs) for the buffer table. Pair: pH and temperature
Pairs	Activation and subsequent entry <ul style="list-style-type: none"> ■ °C -20 ... 150 °C ■ pH -2.00 ... 16.00 pH 	Enter the temperature and the related pH values of your medium (number of required value pairs = number of table points specified in the previous field).
Confirm	Options <ul style="list-style-type: none"> ■ OK ■ Delete element(s) 	Are the value pairs OK or do you want to delete elements? Delete: In the screen that follows, select the row to be deleted, delete with  and confirm with  .
Note	Valid table	The table is active after confirming with  . Cancel with  .
General settings		
Temperature compensation	Options <ul style="list-style-type: none"> ■ ATC ■ MTC 	Select the temperature compensation for the calibration.  Note! The setting is only active during calibration. During operation, the setting you selected in the "Temperature" menu applies.
Slope	5.00 ... 57.00 mV / pH Factory setting 25.00 mV/pH	If the slope entered is undershot, an alarm (error no. 032) can be triggered (for error activation, see "Set up 1 - Alarm" section). Example: The specified slope of the electrode is 59 mV/pH at 25 °C. You enter 55 mV/pH as the slope here. Then an alarm can be triggered where the slope measured < 55 mV/pH.  Note! The upper limit value for the slope is permanently programmed. An alarm is triggered if a slope of 65 mV/pH is overshot.

Function	Options	Info
Zero point	0.05 ... 2.00 pH Factory setting 1.30 pH	If the zero point deviates from the target zero point by the value entered here, an alarm (error no. 033) can be triggered (for error activation, see "Set up 1 - Alarm" section). Example: The specified zero point of the electrode is 7.00 pH (for electrode with pH 7 internal buffer). Enter 0.05 pH as the zero point deviation. Then an alarm can be triggered if the measured zero point is < 6.95 pH or > 7.05 pH.
SCC (Sensor Condition Check)	Options <ul style="list-style-type: none"> ■ On ■ Off Factory setting Off	This function monitors the electrode status or the degree of electrode aging. Possible status messages: "Electrode OK", "Low wear" or "Replace electrode". The electrode status is updated after each calibration. When the "Replace electrode" message appears, an error message may be displayed (E040, E041)..  Note! This function is only available for glass electrodes. If you combine a glass electrode and an ISFET sensor, you can use the SCC function without any restrictions. It only monitors the glass electrode however.
Isothermic compensation	Activation and subsequent entry <ul style="list-style-type: none"> ■ Function <ul style="list-style-type: none"> - On - Off ■ Uis 0.00 ... 16.00 pH Factory setting Function: Off Uis: 0.00 pH	Here you can activate the isotherm compensation and enter the isotherm intersection point (Uis). Function off: For E+H electrodes. Function on: Only if the isotherm intersection point ≠ zero point of the electrode. The bigger the difference between the isotherm intersection point and the zero point, the greater the measuring error in the event of fluctuations in temperature. Uis: Enter the point at which the isotherms of the electrode intersect.  Note! When you activate the isothermic compensation the electrode has to be calibrated before measuring.
Stability criteria	Activation and subsequent entry <ul style="list-style-type: none"> ■ Threshold 01 ... 10 mV ■ Length 03 ... 70 s Factory setting Threshold: 02 mV Length: 20 s	During calibration, the mV value may change during the given period ("duration") at maximum by the stated amount ("threshold"), so that the calibration is considered as stable. You can thus individually adapt the accuracy and time involved to your process.
Calibration timer		
Calibration timer	Activation and subsequent entry <ul style="list-style-type: none"> ■ Cal-Timer <ul style="list-style-type: none"> - On - Off ■ Warning 0001 ... 9999 h Factory setting Cal-Timer: Off Warning: 0001 h	If no calibration is undertaken in the set time, an error message appears (E115). Cal-Timer on: Activate the timer Warning: Enter the time within which the next calibration has to take place. Time: Displays the time remaining until the error message (countdown).

Function	Options	Info
Autocal. Topcal		
Calibration parameters	<p>Options</p> <ul style="list-style-type: none"> ■ Fixed buffer ■ Auto. buffer recognition <p>Factory setting Fixed buffer</p>	<p>Specify the type of calibration for automatic calibration.</p> <p>Buffer table: This function can be selected if the same buffer values are constantly used.</p> <p>Auto. Buffer recognition: The Mycom S transmitter automatically recognizes the buffer values used.</p> <p> Note! Automatic buffer recognition only works if glass electrodes are connected to both measuring circuits. If you are using an ISFET sensor, please calibrate with another calibration function.</p>
Buffer type	<p>Options</p> <ul style="list-style-type: none"> ■ DIN 19267 ■ E+H ■ NBS / DIN 19266 ■ Merck+Riedel ■ Special buffer <p>Factory setting E+H</p>	<p>Select a buffer type where the pH values specified are fixed.</p> <p>Spec. buffer table: The tables for special buffer, which are to be defined in the "Special buffer" option, are used.</p> <p> Note! The buffer tables for the buffer types on offer are provided in the appendix.</p>
Buffer 1	<p>Options</p> <ul style="list-style-type: none"> ■ Buffer 2.0 ■ Buffer 4.01 ■ Buffer 6.98 ■ Buffer 9.18 ■ Buffer 10.90 <p>(option depends on the buffer type)</p> <p>Factory setting Buffer 6.98</p>	<p>Select the pH value for buffer 1 of the two-point calibration.</p>
Buffer 2	<p>Options</p> <ul style="list-style-type: none"> ■ Buffer 2.0 ■ Buffer 4.01 ■ Buffer 9.18 ■ Buffer 10.90 <p>(option depends on the buffer type)</p> <p>Factory setting Buffer 4.01</p>	<p>Select the pH value for buffer 2 of the two-point calibration.</p>

Redox operating mode

To call the menu, select:

" > Specialist > Set up 1 > Calibration"

Function	Options	Info
Calibration	<p>Options</p> <ul style="list-style-type: none"> ■ Offset ■ Onsite calibration type ■ Cal settings ■ Calibration timer ■ Autocal. Topcal <p>Factory setting Offset</p>	<p>Select the initial settings for the calibration.</p> <p>Offset: Enter a fixed value by which the mV value is shifted.</p> <p>Manual calibration: Make initial settings for the function of the CAL key.</p> <p>Cal settings: General calibration settings</p> <p>Calibration timer: Timer for calibration intervals</p> <p>Autocal. Topcal: Make initial settings for the Topcal S method of calibration.</p>

Function	Options	Info
Offset		
Enter offset	Activation and subsequent entry <ul style="list-style-type: none"> ■ Act. PV 1/2 0000 ... 1500 mV ■ Offset 1/2 0000 ... 1500 mV Factory setting Offset: 0000 mV	Act. PV: The current measured value (primary value) with an offset is displayed and can be edited. Offset: The mV difference between the measured value and the displayed value is displayed and can be edited. If you start operation with a set offset value, "OFFSET" is shown on the top right of the display.
Onsite calibration type		
Calibration parameters	Options <ul style="list-style-type: none"> ■ Enter data abs. ■ Calibration abs. ■ Enter data rel. (only Redox/ORP: % operating mode) ■ Calibration rel. (only Redox/ORP: % operating mode) Factory setting Enter data abs.	Specify the type of calibration with which calibration takes place when the "CAL" button is pressed. Enter data abs.: Enter the electrode offset in mV. Calibration abs.: Use a redox buffer Enter data rel.: Entry of two % calibration points to each of which one mV value is assigned. Calibration rel.: Use a detoxicated and an unchanged sample as the buffer.
General settings		
Zero point	1 ... 1500 mV Factory setting Function: Off Maintenance: 10.50 pH Failure: 11.00 pH	If the zero point deviates from the target zero point by the value entered here, an alarm (error no. 033) can be triggered (for error activation, see "Set up 1 - Alarm" section).
SCC (Sensor Condition Check)	Options <ul style="list-style-type: none"> ■ On ■ Off Factory setting Off	This function monitors the electrode status or the degree of electrode aging. Possible status messages: "Electrode OK", "Low wear" or "Replace electrode". The electrode status is updated after each calibration. When the "Replace electrode" message appears, an error message may be displayed (E040, E041)..  Note! This function is only available for glass electrodes. If you combine a glass electrode and an ISFET sensor, you can use the SCC function without any restrictions. It only monitors the glass electrode however.
Stability criteria	Activation and subsequent entry <ul style="list-style-type: none"> ■ Threshold 01 ... 10 mV ■ Length 03 ... 70 s Factory setting Threshold: 02 mV Length: 10 s	During calibration, the mV value may change during the given period ("duration") at maximum by the stated amount ("threshold"), so that the calibration is considered as stable. You can thus individually adapt the accuracy and time involved to your process.
Calibration timer		
Calibration timer	Activation and subsequent entry <ul style="list-style-type: none"> ■ Cal-Timer <ul style="list-style-type: none"> - On - Off ■ Warning 0001 ... 9999 h Factory setting Cal-Timer: Off Warning: 0001 h	If no calibration is undertaken in the set time, an error message appears (E115). Cal-Timer on: Activate the timer Warning: Enter the time within which the next calibration has to take place. Time: Displays the time remaining until the error message (countdown).

Function	Options	Info
Autocal. Topcal		
Calibration solution	-1500 ... 1500 mV Factory setting 450mV	Specify the calibration solution for the automatic Topcal calibration.

7.6.10 Set up 1 - Topcal validation function

If you are using a pH electrode, you can use the validation function to check whether there is a deviation between the target and actual value of your measurement and whether calibration is necessary. For this purpose, various buffers (P1, P2) are pumped into the rinse chamber of the retractable assembly. The pH value measured there is compared to the specified pH value of the buffer. The calculated deviation is saved in the validation logbook.

To call the menu, select:

" > Specialist > Set up 1 > Validation fct. Topcal

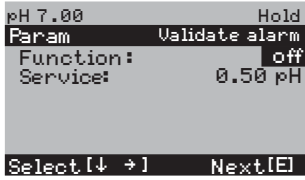
Function	Options	Info
Validate alarm 	Activation and subsequent selection <ul style="list-style-type: none"> ■ Function <ul style="list-style-type: none"> - On - Off ■ Maintenance <ul style="list-style-type: none"> 0.00 ... 5.00 pH Factory setting Function: Off Maintenance: 0.50 pH	Select the deviation between the actual and target value for the pH value in the event of which an alarm should be triggered.
Validation program	Activation and subsequent selection <ul style="list-style-type: none"> ■ Template <ul style="list-style-type: none"> - Val. P1 - Val. P2 - Val. P1/P2 - Val+Cal ■ Target <ul style="list-style-type: none"> - User prog. 1 - User prog. 2 - User prog. 3 - No prog. 	Select a template for the validation. Select a user program as the target. The corresponding user program is then overwritten by the validation program.

7.6.11 Set up 2 - Data log

The data logger records two freely selectable parameters with their date and time. You can call it up by means of the measured value displays. Use the arrow keys to scroll through the measured value displays until you get to the record mode of the data logger. Press the key to enter the scroll mode of the data logger. Here you can open the saved measured values with their date and time.

To call the menu, select:

" > Specialist > Set up 2 > Data log"

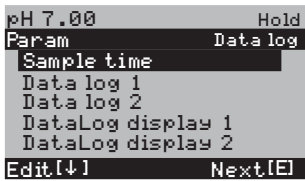
Function	Options	Info
Data logger 	Options <ul style="list-style-type: none"> ■ Sample time ■ Data log 1 ■ Data log 2 ■ DataLog display 1 ■ DataLog display 2 Factory setting Sample time	With the data loggers you can <ul style="list-style-type: none"> ■ record a parameter with 500 consecutive measuring points. ■ two parameters each with 500 sequential measuring points.

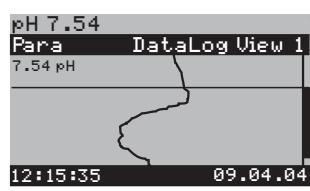
Function	Options	Info
Sample time		
Enter sample time	2 ... 36000 s Factory setting 00005 s	Enter the time interval after which the next measured value is recorded in the data logger.
Data logger		
Data log 1 (or 2)	Activation and subsequent entry <ul style="list-style-type: none"> ■ Measured value <ul style="list-style-type: none"> - pH/mV - Temp ■ Function <ul style="list-style-type: none"> - On - Off Factory setting Input: pH/mV Function: Off	Select the measured value to be recorded and activate the function with "On".
Recording range	Activation and subsequent entry <ul style="list-style-type: none"> ■ Min <ul style="list-style-type: none"> -2.00 ... 16.00 pH -1500 ... 1500 mV -50 ... 150 °C ■ Max <ul style="list-style-type: none"> -2.00 ... 16 pH -1500 ... 1500 mV -50 ... 150 °C Factory setting Min: 2.00 pH Max: 12.00 pH	Specify the recording range. Values outside the range defined here are not recorded.
DataLog display		
		View of the recorded data You can call up the data recorded in the past with date and time.

7.6.12 Set up 2 - Check

SCS electrode monitoring

The sensor check system monitors the pH and reference electrode for incorrect measurement and total failure.

SCS detects the following reasons for incorrect measurement:

- Electrode glass breakage
- Fine short circuits in the pH measuring circuit, including moisture or contamination bridges at the terminal points
- Fouling or clogging of the reference electrode
- Leak current for ISFET sensor

The following three monitoring methods are used:

- Monitoring of the high impedance of the pH electrode (alarm when a minimum impedance is undershot, approx. 500 k Ω).

This function cannot be selected for antimony and ISFET electrode types.

- Monitoring the impedance of the reference electrode (alarm when the set threshold value is overshot).

This function can only be selected for symmetrically high-impedance measurement.

- Monitoring the leak current for ISFET sensors (early warning E168 with $I_{LEAK} > 200$ nA, error E008 with $I_{LEAK} > 400$ nA).

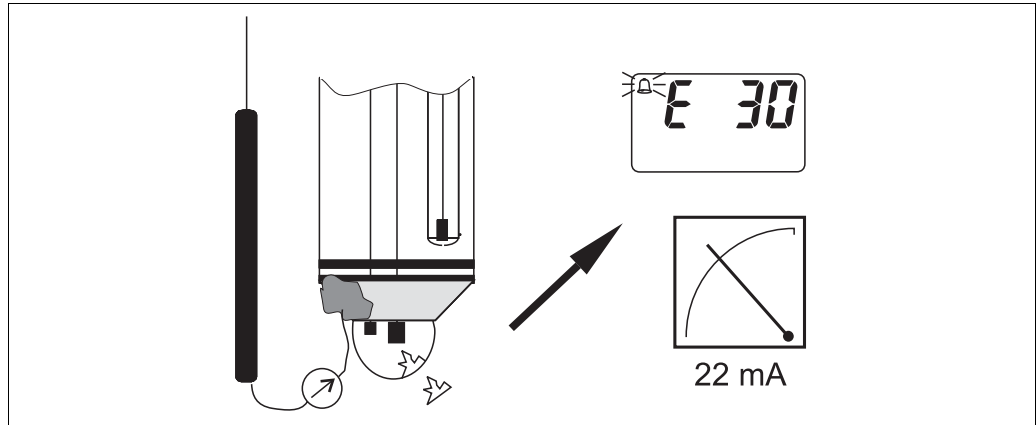

Fig. 52: SCS alarm



Caution!

Do not remove standard electrodes from the process without hold! As SCS is measured against PML, an alarm occurs due to the missing contact between the internal lead and PML. In the case of digital sensors, SCS is not measured against PML.

PCS alarm (Process Check System)

The measuring signal is examined for deviations with the PCS. An alarm is triggered (E152) if the change in the measuring signal is smaller than 0.5% (of the full scale value of the selected measuring range) within the time entered. The reason for such sensor behavior can be fouling, cable rupture or similar.

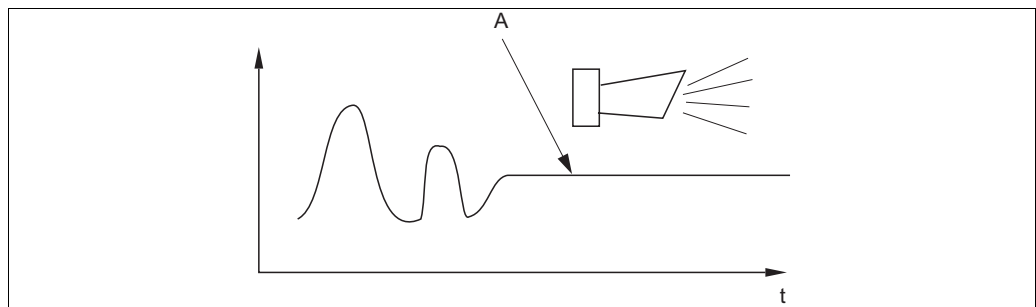

Fig. 53: PCS alarm (Live Check)

A Constant measuring signal = Alarm is triggered once the PCS alarm time elapses





Note!

- The electrode must be connected symmetrically (with PML) to monitor the reference.
- A PCS alarm pending is cleared automatically once the sensor signal changes.
- Due to its semiconductor component, the ISFET sensor is sensitive to light and reacts with fluctuations in the measured value. Therefore, avoid direct sunlight during calibration and operation. Normal ambient light does not affect measurement.

Check menu

To call the menu, select:

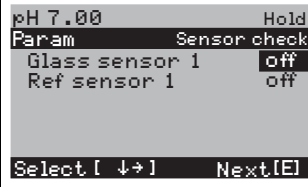
" > Specialist > Set up 2 > Check"

Function	Options	Info
SCS (Sensor Check System) 	Activation and subsequent entry <ul style="list-style-type: none"> ■ Glass sensor <ul style="list-style-type: none"> - On - Off ■ Ref. sensor <ul style="list-style-type: none"> - Off - light - medium - Heavy - Very heavy Factory setting Glass sensor 1: Off Ref. sensor 1: Off	Select the check mode. Glass sensor: Glass breakage detection Ref. sensor: Blockage detection
PCS (Process Check System)	Activation and subsequent entry <ul style="list-style-type: none"> ■ PCS <ul style="list-style-type: none"> - Off - 1h - 2h - 4h Factory setting Off	An alarm occurs with error message E152 if the measuring signal does not change by ± 0.02 pH / ± 5 mV / $\pm 0.25\%$ over the time entered.  Note! A PCS alarm signal pending is cleared automatically once the sensor signal changes.

7.6.13 Set up 2 - Controller configuration



Note!

The following sections describe the controller configuration of the transmitter.

Detailed information on the general functioning of controllers is provided on the CD-ROM D+ supplied.

Configuration of the transmitter

Please configure the relays of the transmitter in the following order:

1. Type
2. Sensor input
3. Characteristic



In the user settings (see below), you go directly to a controller simulation and can check the settings made and change them where necessary.

To call the menu, select:

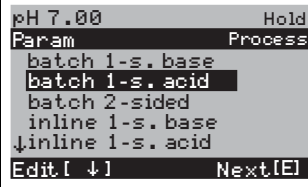
" > Specialist > Set up 2 > Controller settings"

Function	Options	Info
Process 	Options <ul style="list-style-type: none"> ■ Batch 1-s. base ■ Batch 1-s. acid ■ Batch 2-sided ■ Inline 1-s. base ■ Inline 1-s. acid ■ Inline 2-sided Factory setting Batch 1-s. base	Select the process type that describes your process. 1-sided: Control takes place via acid or base. 2-sided: Control takes place via acid and base. This function can only be selected if you defined two controllers (in the "Relays" menu and/or via current output 2).

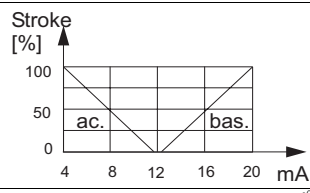
Function	Options	Info
External hardware	Options <ul style="list-style-type: none"> ■ Type ■ Characteristic Factory setting Characteristic	You must configure these submenus completely for correct operation. Type: Here you can select and configure the method the controller uses to output its manipulated variable. Characteristic: Here you can enter the controller parameters (neutral zone, set point, etc.). You also achieve "active measured value display" via this option.
Type for "1-sided" process type		
Control signal	Options <ul style="list-style-type: none"> ■ Pulse length ■ Pulse frequency ■ Current output (only if "Continuous controller" option selected for current output 2) 	Select the type of control for your process.  Note! Detailed information on the types of control is provided on the CD-ROM D+.
Pulse length		
Actuator	Activation and subsequent entry <ul style="list-style-type: none"> ■ Relay: n.c., rel. x ■ Period 001.0 ... 999.9 s ■ Min. on time 000.4 ... 100.0 s Factory setting Relay: n.c. Period: 010.0 s Min. on time: 000.4 s	Select the settings for the actuator. Relay: Select the relay; you can choose from the relays that you assigned to the controller in "Set up 1 - Relays". Period: Period length T in seconds Min. on time: Minimum switch-on time; shorter pulses are not passed on to the relay and thus protect the actuator.
Pulse frequency		
Actuator	Activation and subsequent entry <ul style="list-style-type: none"> ■ Relay: n.c., rel. x ■ Max. frequency 060 ... 120 min⁻¹ Factory setting Relay: n.c. Max. frequency: 120 min ⁻¹	Select the settings for the actuator. Relay: Select the relay; you can choose from the relays that you assigned to the controller in "Set up 1 - Relays". Max. pulse frequency: Enter the maximum pulse frequency; pulses with a higher frequency are not passed on to the relay.
Current output		
Current range	Options <ul style="list-style-type: none"> ■ 0 ... 20mA ■ 4 ... 20 mA Factory setting 4 ... 20 mA	Select the current range to be output at the current output.
Current value	Options <ul style="list-style-type: none"> ■ 20 mA ■ 0/4 mA Factory setting 0/4 mA	Assign the current value that corresponds to 100 % supply of dosing agent.
Type for "2-sided" process type		
Control signal (only if continuous controller was selected under current output 2)	Options <ul style="list-style-type: none"> ■ 1 output ■ 2 outputs Factory setting 2 outputs	1 output: For the control signal via the current output in the "Split range" method. Control logics are required which can control two valves/pumps over one current input. 2 outputs: The valves are controlled via the relay.

Function	Options	Info
1 output		
Current range	Options <ul style="list-style-type: none"> 0 ... 20mA 4 ... 20 mA Factory setting 4 ... 20 mA	Select the current range to be output at current output 2. The neutral position (= current value which the controller outputs when it is not dosing) is in the middle of the selected range. For 0 ... 20 mA, the neutral position is at 10 mA, for 4 ... 20 mA at 12 mA.
Current value	Options <ul style="list-style-type: none"> 20 mA 0/4 mA Factory setting 0/4 mA	Assign the current value that corresponds to 100 % acid dosing.  Note! From the current value selected for the dosing of 100% acid, you can derive the current ranges for acid/base dosing (see Fig. 54) in the "Split range" method.
		 <p style="text-align: right; font-size: small;">a0004343-en</p>
2 outputs		
Control type	Activation and subsequent entry <ul style="list-style-type: none"> Acid <ul style="list-style-type: none"> Pulse length Pulse frequency Base <ul style="list-style-type: none"> Pulse length Pulse frequency Factory setting Acid: Pulse length Base: Pulse length	Select the type of control for your process.  Note! Detailed information on the types of control is provided on the CD-ROM D+.
For acid/base dosing in each case: Actuator (only for pulse length)	Activation and subsequent entry <ul style="list-style-type: none"> Relay: <ul style="list-style-type: none"> n.c., rel. x Period <ul style="list-style-type: none"> 001.0 ... 999.9 s Min. on time <ul style="list-style-type: none"> 000.4 ... 100.0 s Factory setting Relay: n.c. Period: 010.0 s Min. on time: 000.4 s	Select the settings for the actuator. Relay: Select the relay; you can choose from the relays that you assigned to the controller in "Set up 1 - Relays". Period: Period length T in seconds Min. on time: Minimum switch-on time; shorter pulses are not passed on to the relay and thus protect the actuator.
For acid/base dosing in each case: Actuator (only for pulse frequency)	Activation and subsequent entry <ul style="list-style-type: none"> Relay: <ul style="list-style-type: none"> n.c., rel. x Max. frequency <ul style="list-style-type: none"> 060 ... 120 min⁻¹ Factory setting Relay: n.c. Max. frequency: 120 min ⁻¹	Select the settings for the actuator. Relay: Select the relay; you can choose from the relays that you assigned to the controller in "Set up 1 - Relays". Max. pulse frequency: Enter the maximum pulse frequency; pulses with a higher frequency are not passed on to the relay.
Characteristic		
Characteristic type	Options <ul style="list-style-type: none"> Linear Segmented 	Select the characteristic type. Linear characteristic Corresponds to a constant control gain. Segmented characteristic Corresponds to a range-dependent control gain.

Function	Options	Info
Linear curve		
characteristic values	Activation and subsequent entry <ul style="list-style-type: none"> ■ Start neutral zone -2.00 ... 7.00 pH ■ End neutral zone 7.00 ... 16.00 pH ■ Control point -2.00 ... 16.00 pH (depends on start neutral and end neutral zone) ■ K_R 1 00.00 ... 99.99 ■ K_R 2 00.00 ... 99.99 Factory setting Start neutral zone: 6.50 pH End neutral zone: 7.50 pH Control point: 7.00 pH K_R 1: 01.00 K_R 2: 01.00	Select the settings for linear control gain. Control point: The value that is to be set. Start neutral zone: Start neutral zone End neutral zone: End neutral zone K_R 1 (only for base dosing): Gain for base dosing K_R 2 (only for acid dosing): Gain for acid dosing
Process character	Options <ul style="list-style-type: none"> ■ Fast process ■ Standard process ■ Slow process ■ User Factory setting Fast process	Select the character of the process. If you have no values from experience for setting the control parameters, these default settings for a rapid/standard/slow process should help you in adjusting the controller. Select a default value and use the "Simulation" (see below) to check whether these settings apply to your process. Enter all the characteristic values yourself with the user settings.
Values for user settings (only if "User" selected for the process character)	Activation and subsequent entry <ul style="list-style-type: none"> ■ K_R 1 00.00 ... 99.99 ■ K_R 2 00.00 ... 99.99 ■ T_n 1 000.0 ... 999.9 ■ T_n 2 000.0 ... 999.9 ■ T_v 1 000.0 ... 999.9 ■ T_v 2 000.0 ... 999.9 Factory setting K_R 1: 01.00 K_R 2: 01.00 T_n 1: 000.0 T_n 2: 000.0 T_v 1: 000.0 T_v 2: 000.0	Enter the characteristic values for the user settings. (Index 1 only for base dosing, index 2 only for acid dosing) K_R 1: Gain for base dosing K_R 2: Gain for acid dosing T_n: Integral action time T_v: Derivative action time
Controller simulation	Options <ul style="list-style-type: none"> ■ On ■ Off Factory setting Off	Here, you can switch a configuration loop on or off. Hold is taken away when controller simulation is activated. Simulation on: The characteristic values entered in the previous field are used in the next field for simulating the controller behavior. Off: Controller simulation is exited when you confirm with $\boxed{\text{E}}$.

Function	Options	Info
Simulation on	Activation and subsequent entry <ul style="list-style-type: none"> ■ Function <ul style="list-style-type: none"> – Auto – Manual ■ Set <ul style="list-style-type: none"> –2.00 ... 16 pH ■ Act. ■ y <ul style="list-style-type: none"> –100 ... 100 % (only if function = manual) 	<p>Function: Here you can specify whether the manipulated variable calculated by the controller should be output for "Automatic" or whether a manipulated variable y to be entered by the user should be output for "Manual".</p> <p>Control point: Displays the current set point. If necessary, you can change the set point. The other points (start/end of neutral zone, optimization points, control points) change accordingly.</p> <p>Act: Displays the current actual value/measured value.</p> <p>y: For the "Automatic" function: Displays the manipulated variable determined by the controller. With the "manual" function, you can enter an actuating variable here. Values < 0 % mean acid dosing, values > 0 % mean base dosing.</p>
Segmented curve		
characteristic values	Activation and subsequent entry <ul style="list-style-type: none"> ■ Start neutral zone <ul style="list-style-type: none"> –2.00 ... 7.00 pH ■ End neutral zone <ul style="list-style-type: none"> 7.00 ... 16.00 pH ■ Control point <ul style="list-style-type: none"> –2.00 ... 16.00 pH (depends on start neutral and end neutral zone) ■ Opt. pt. X1 <ul style="list-style-type: none"> 2.00 ... 7.00 pH (depends on start neutral zone) ■ Opt. pt. Y1 <ul style="list-style-type: none"> 00.00 ... 99.99 ■ Opt. pt. X2 <ul style="list-style-type: none"> 7.00 ... 16.00 pH (depends on end neutral zone) ■ Opt. pt. Y2 <ul style="list-style-type: none"> 00.00 ... 99.99 ■ Control point 1 <ul style="list-style-type: none"> 2.00 ... 7.00 pH (depends on opt. pt. X1) ■ Control point 2 <ul style="list-style-type: none"> 7.00 ... 16.00 pH (depends on opt. pt. X2) <p>Factory setting Start neutral zone: 6.50 pH End neutral zone: 7.50 pH Control point: 7.00 pH Opt. pt X1: 05.00 pH Opt. pt Y1: 0.20 Opt. pt X2: 09.00 pH Opt. pt Y2: –0.20 Control point 1: 02.00 pH Control point 2: 12.00 pH</p>	Enter the characteristic values for range-dependent control gain. <p>Control point: The value that is to be set. Start neutral zone: Start neutral zone End neutral zone: End neutral zone Optimization point 1 and 2: Entry with x and y coordinates Control point 1: For measured values < control point 1, the dosing is 100% base. Control point 2: For measured values > control point 2, the dosing is 100% acid.</p>

Function	Options	Info
Parameter	Activation and subsequent entry <ul style="list-style-type: none"> ■ Tn 1 000.0 ... 999.9 ■ Tn 2 000.0 ... 999.9 ■ Tv 1 000.0 ... 999.9 ■ Tv 2 000.0 ... 999.9 Factory setting Tn 1: 000.0 Tn 2: 000.0 Tv 1: 000.0 Tv 2: 000.0	Enter the parameters for the segmented curve. (Index 1 only for base dosing, index 2 only for acid dosing) Tn: Integral action time Tv: Derivative action time
Controller simulation	Options <ul style="list-style-type: none"> ■ On ■ Off Factory setting Off	Here, you can switch a configuration loop on or off. Hold is taken away when controller simulation is activated. Simulation on: The characteristic values entered in the previous field are used in the next field for simulating the controller behavior. Off: Controller simulation is exited when you confirm with E .
Simulation on	Activation and subsequent entry <ul style="list-style-type: none"> ■ Function <ul style="list-style-type: none"> - auto - manual ■ Set -2.00 ... 16 pH ■ Act. ■ y -100 ... 100 % (only if function = manual) 	Function: Here you can specify whether the manipulated variable calculated by the controller should be output for "Automatic" or whether a manipulated variable y to be entered by the user should be output for "Manual". Control point: Displays the current set point. If necessary, you can change the set point. The other points (start/end of neutral zone, optimization points, control points) change accordingly. Act: Displays the current actual value/measured value. y: For the "Automatic" function: Displays the manipulated variable determined by the controller. With the "manual" function, you can enter an actuating variable here. Values < 0 % mean acid dosing, values > 0 % mean base dosing.

To best adapt the controller parameters to the process, we recommend the following:

1. Set values for controller parameter ("Values for user settings" field for linear curve or "Parameter" field for segmented curve).
2. Deflect the process.
"Simulation" field: Set function to "Manual" and enter a manipulated variable. Using the actual value, you can observe how the process is deflected.
3. Switch the function to "auto". Now you can observe how the controller returns the actual value to the set point.
4. If you want to set other parameters, press "Enter" and you come back to the "Values for user settings" field. During this time, the controller continues to run in the background.
5. Press the "Enter" key to return to the "Select simulation" field. You can continue or end simulation here.



Note!

Always end controller simulation with "Simulation off" in the "Select simulation" field. Otherwise, the simulation will continue to run in the background.

7.6.14 Set up 2 - Limit switch

The transmitter has various methods of assigning a relay contact.

An on-value and off-value can be assigned to the limit switch as can a pick-up delay and drop-out delay. Furthermore, if an alarm threshold is set an error message can also be output and a cleaning function can be started in conjunction with this.

These functions can be used for both the primary value and for temperature measurement.

You can refer to the switching states in Fig. 55 to clearly understand the contact states of the relay.

- With increasing measured values (maximum function), the relay contact is closed as of t_2 when the on value (t_1) is exceeded and the pull-up delay ($t_2 - t_1$) has elapsed. The fault-signaling contact switches if the alarm threshold (t_3) is reached and the alarm delay ($t_4 - t_3$) has also elapsed.
- When the measured values decrease, the fault-signaling contact is reset again when the alarm threshold (t_5) is undershot as is the relay contact (t_7) later on after the drop-out delay ($t_7 - t_6$).
- When the pick-up and drop-out delay are set to 0 s, the switch-on and switch-off points are also switch points of the contacts.

In line with the maximum function, the same settings can also be made for a minimum function.

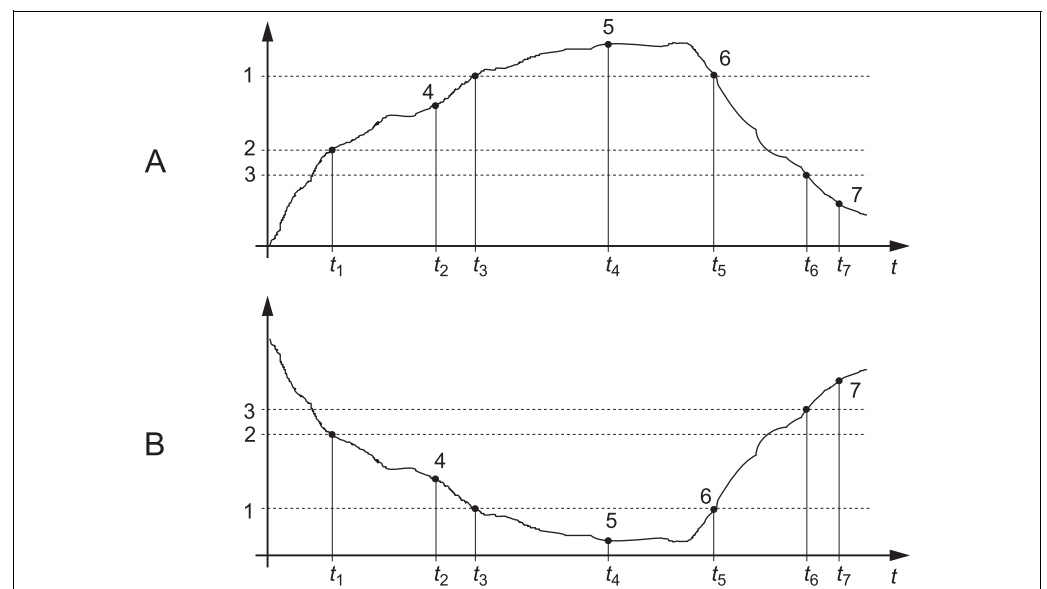



Fig. 55: Illustration of the alarm value and limit value functions

- | | | | |
|---|---|---|------------------|
| A | Switch-on point > switch-off point: Max. function | 1 | Alarm threshold |
| B | Switch-on point < switch-off point: Min. function | 2 | Switch-on point |
| | | 3 | Switch-off point |
| | | 4 | Contact ON |
| | | 5 | Alarm ON |
| | | 6 | Alarm OFF |
| | | 7 | Contact OFF |

Limit switch menu

To call the menu, select:

" > Specialist > Set up 2 > Limit switch"

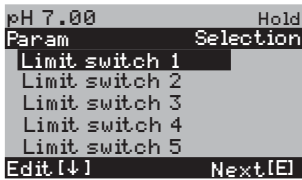
Function	Options	Info
Limit switch 	Options <ul style="list-style-type: none"> ■ Limit switch 1 ■ Limit switch 2 ■ Limit switch 3 ■ Limit switch 4 ■ Limit switch 5 	Select the limit switch you want to configure. There are five limit contactors available.
Limit switch 1 ... 5	Activation and subsequent entry <ul style="list-style-type: none"> ■ Function <ul style="list-style-type: none"> - On - Off ■ Assignment <ul style="list-style-type: none"> - pH/mV Input 1 - Temperature Input 1 ■ On value: <ul style="list-style-type: none"> -2.00 ... 16.00 pH -1500 ... 1500 mV -3000 ... 3000 % -50 ... 150 °C ■ Off value <ul style="list-style-type: none"> -2.00 ... 16.00 pH -1500 ... 1500 mV -3000 ... 3000 % -50 ... 150 °C Factory setting Function: Off Assignment: pH/mV On-value: 16.00 pH Off-value: 16.00 pH	Configure the limit switch. Function: Activate the function as a limit switch Assignment: Select the measured value to which the limit value should apply. On-value: Enter the value at which the limit function is activated. Off-value: Enter the value at which the limit function is deactivated.
Limit switch configuration	Activation and subsequent entry <ul style="list-style-type: none"> ■ On delay <ul style="list-style-type: none"> 0 ... 2000 s ■ Off delay <ul style="list-style-type: none"> 0 ... 2000 s ■ Alarm lim. <ul style="list-style-type: none"> -2.00 ... 16.00 pH -1500 ... 1500 mV -3000 ... 3000 % -50 ... 150 °C Factory setting On delay: 0s Off delay: 0s Alarm lim.: 16.00 pH	Configure the delays and the alarm threshold for the limit switch. On delay: Enter the on delay Off delay: Enter the off delay Alarm limit: Enter the value at which the fault-signaling contact switches.

7.6.15 Set up 2 - Controller quick adjustment

In this menu, you can make a quick correction to the controller set point:

To call the menu, select:

" > Specialist > Set up 2 > Contr. quick adj."

Function	Options	Info
Controller quick adjustment pH 7.00 Hold Param Quick adjustm. Function off set. 7.00 pH act. 6.58 pH Select [→] Next [E]	Activation and subsequent entry ■ Control point -1.64 ... 15.64 pH	Enter the set point for the controller function.

7.6.16 Set up 2 - Topcal

Use this menu item to configure the cleaning and calibration cycles and how cleaning and calibration are triggered.

Configuration of the programs

The following cleaning and calibration programs are available in Topcal S:

- Clean: Predefined program for cleaning the sensor
- Clean S: Predefined program for cleaning and sterilizing the sensor
- Clean C: Predefined program for cleaning and calibrating the sensor
- Clean CS: Predefined program for cleaning, calibrating and sterilizing the sensor
- User 3: Predefined program with short program times to check the system quickly
- User 1/2: Free program slots without predefined program steps

The predefined programs are used for simple programming. You can, however, configure all the programs as you wish to adapt them optimally to your needs and requirements.

To configure the programs, select " > Set up 2 > Topcal > Config. Topcal > Prog. editor".



Note!

- In the programs, you can use external additional valves as required, e.g. for superheated steam, a second cleaner, cooling air, organic cleaners etc. You control the additional valves with the "Valve x open", "Valve x closed" program steps.

Controlling the cleaning and calibration programs

You can choose from the following ways to control cleaning and calibration programs:

- Automatic:
Weekly program that automatically starts the selected cleaning program for every weekday. You can freely select the programs in question for every weekday.
- Cleaning:
Select the cleaning program that is started in the event of an SCS alarm (see "Set up 2 - Check systems" section) or as per the configured error messages (see "Set up 1 - Alarm" section).
- Power failure program:
Select the cleaning program that is automatically started after a power or air supply failure or if communication fails.
- Ext. control:
The cleaning and calibration programs can be started by means of a process control system. The programs are started by means of a 3-bit signal. Please refer to the table in the "Function overview of the cleaning and calibration programs" section for the binary encoding of the individual programs.
Please refer also to the "Connecting the external inputs and outputs to the control unit" section for the electrical connection of the binary encoding for an external program start.



Note!

The appendix contains an example of wiring for the external control of the cleaning programs.

Activating the types of control

To activate the type of control for the cleaning and calibration programs, switch the desired function on. To do so, select "PARAM > Set up 2 > Topcal > Activate Topcal".

Cleaning and calibration cycle

With the interval program, you can start any cleaning or calibration program in a set timeframe (max. 1 day) at defined intervals. The program cycle is illustrated in Fig. 56.

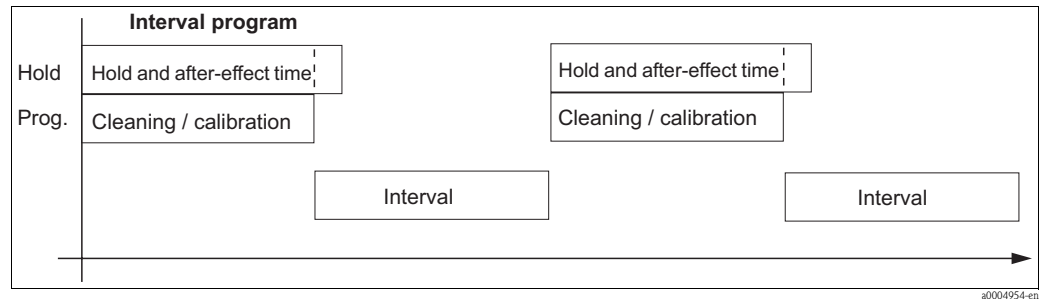

Fig. 56: Interval program cycle

Select the program and the interval between program starts under "PARAM > Set up 2 > Topcal > Config. Topcal > Interv.prog.".

This program for a cleaning cycle is only available within the "Automatic" type of control.

In practice, two different operating modes are used – measuring cycles and cleaning cycles:

- In the cleaning cycle mode, the sensor is primarily in the process. The sensor is cleaned at the specified intervals.

Configuration example for cleaning cycles

1. Select "PARAM > Set up 2 > Topcal > Config. Topcal > Interv.prog.".
2. Select the "Clean" program with its factory settings as the interval-based program.
3. Enter "10800 s" as the interval time.

The sensor measures for 3 hours, is then taken out of the process and cleaned. It is then put back into the process for another 3 hours.

- During measuring cycles, the sensor is primarily in the Service position (aggressive media). It is then moved into the process for measuring at the specified intervals.

Configuration example for measuring cycles

1. Edit the "Clean" program. For this purpose, select "Set up 2 > Topcal > Setup Topcal > Prog. editor".
2. Select the "Clean" program.
3. Select "Edit".
 - As the first program step, enter "Assembly measuring".
 - As the second program step, enter "Wait".
 - Delete the last program step "Assembly measuring".
4. Use "PARAM" to go back to the higher-order program group.
5. Select "Setup".
 - Set a time of 180 seconds for the second program step "Wait".
6. Use "PARAM" to go back until you can select "Interv. program".
 - Select "Clean" as the program.
 - Select "10800 s" as the interval time.

Every three hours, the sensor is moved into the process to measure for three minutes.

Aborting programs

A program that has been started (Clean, Clean C, Clean S, Clean CS) goes through the entire cycle (safety concept). During this time, no other programs can be started.

The service switch on the front door of the control unit has the highest priority. If you move the switch to the "Service" position, you can also interrupt ongoing programs during operation.

You can interrupt the interval program with a permanent signal at the "Automatic stop" digital input.

The assembly has to be in the "Measure" position for this. The interval program is continued if a signal is no longer present at the aforementioned input.

Controlling the cleaning and calibration programs via binary contacts

Program	bin. 0	bin. 1	bin. 2
	Term. 81/82	Term. 83/84	Term. 85/86
Clean (cleaning)	1	0	0
Clean C (cleaning + calibration)	0	1	0
Clean S (cleaning + sterilization)	0	0	1
Clean CS (cleaning + calibration + sterilization)	1	1	0
User 1 (freely selectable)	1	0	1
User 2 (freely selectable)	0	1	1
User 3 (freely selectable)	1	1	1



Note!

- "1" = Voltage of 10 ... 40 V (duration approx. 400 mS) applied at contacts bin 0 ... bin 2 (terminals 81 ... 86). This auxiliary voltage can be taken from the 15 V auxiliary voltage output of Mycom S CPM153 for non-Ex devices.
- "0" = 0 V

Standard program cycles

Clean		Clean C		Clean S		Clean CS		User 3 (quick test)	
01	Assembly service	01	Assembly service	01	Assembly service	01	Assembly service	01	Assembly service
02	Water 60 s	02	Water 60 s	02	Valve 1 open	02	Water 60 s	02	Water 10 s
03	Cleaner 3s	03	Cleaner 3s	03	Wait 1200s	03	Cleaner 3s	03	Compressed air 10 s
04	Wait 120s	04	Wait 120s	04	Valve 1 close	04	Wait 120s	04	Cleaner 2s
05	Water 60 s	05	Water 60 s	05	Wait 600s	05	Water 60 s	05	Wait 5s
06	Compressed air 20s	06	Compressed air 20s	06	Repeat steril. 0x	06	Compressed air 20s	06	Pump buffer 1 2s
07	Rep. cleaning 1x	07	Rep. cleaning 1x	07	Assembly measuring	07	Rep. cleaning 1x	07	Wait 5s
08	Assembly measuring	08	Pump buffer 1 3s	08		08	Pump buffer 1 3s	08	Pump buffer 2 2s
09		09	Wait 300s	09		09	Wait 300s	09	Wait 5s
10		10	Cal. Buffer 1	10		10	Cal. Buffer 1	10	Valve 1 open
11		11	Water 60 s	11		11	Water 60 s	11	Wait 5s
12		12	Compressed air 20s	12		12	Compressed air 20s	12	Valve 1 close
13		13	Pump buffer 2 3s	13		13	Pump buffer 2 3s	13	Wait 5s
14		14	Wait 300s	14		14	Wait 300s	14	Valve 2 open
15		15	Cal. Buffer 2	15		15	Cal. Buffer 2	15	Wait 5s
16		16	Water 60 s	16		16	Water 60 s	16	Valve 2 close
17		17	Compressed air 20s	17		17	Compressed air 120s	17	Wait 5s
18		18	Assembly measuring	18		18	Valve 1 open	18	Compressed air 15s
19		19		19		19	Wait 1200s	19	Assembly measuring
20		20		20		20	Valve 1 close		
21		21		21		21	Wait 600s		
22		22		22		22	Repeat steril. 0x		
23		23		23		23	Assembly measuring		
24		24		24		24			
25		25		25		25			
26		26		26		26			
27		27		27		27			
28		28		28		28			

Optional program cycles

User 1 - User2*	Val. P1	Val. P2	Val. P1/2	Val+Cal.
01	01 Assembly service	01 Assembly service	01 Assembly service	01 Assembly service
02	02 Water 60 s	02 Water 60 s	02 Water 60 s	02 Water 60 s
03	03 Cleaner 3s	03 Cleaner 3s	03 Cleaner 3s	03 Cleaner 3s
04	04 Wait 120s	04 Wait 120s	04 Wait 120s	04 Wait 120s
05	05 Water 60 s	05 Water 60 s	05 Water 60 s	05 Water 60 s
06	06 Compressed air 20s	06 Compressed air 20s	06 Compressed air 20s	06 Compressed air 20s
07	07 Back to 2 1x	07 Back to 2 1x	07 Back to 2 1x	07 Back to 2 1x
08	08 Pump buffer 1 3s	08 Pump buffer 2 3s	08 Pump buffer 1 3s	08 Pump buffer 1 3s
09	09 Wait 60 s	09 Wait 60 s	09 Wait 60 s	09 Wait 60 s
10	10 Val. buffer 1	10 Val. buffer 2	10 Val. buffer 1	10 Val. buffer 1
11	11 Water 60 s	11 Water 60 s	11 Water 60 s	11 Cal. Buffer 1
12	12 Compressed air 20s	12 Compressed air 20s	12 Compressed air 20s	12 Water 60 s
13	13 Assembly measuring	13 Assembly measuring	13 Pump buffer 2 3s	13 Compressed air 20s
14	14	14	14 Wait 60 s	14 Pump buffer 2 3s
15	15	15	15 Val. buffer 2	15 Wait 60 s
16	16	16	16 Water 60 s	16 Val. buffer 2
17	17	17	17 Compressed air 20s	17 Cal. Buffer 2
18	18	18	18 Assembly measuring	18 Water 60 s
19	19	19	19	19 Compressed air 20s
20	20	20	20	20 Assembly measuring
21 (up to 28 program steps possible)	21	21	21	21
22	22	22	22	22

* For redox measurement, the "RedoxCal" program is available instead of the "User 1" program (see the following page).

Programs for redox operating mode

You cannot calibrate with the Clean C and Clean CS calibration programs in the redox operating mode. Instead, you can use the "Redox Cal." program in User program 1.

RedoxCal		
01	Assembly service	
02	Water	60 s
03	Cleaner	3s
04	Wait	120s
05	Water	60 s
06	Compressed air	20s
07	Back to 2	1x
08	Pump buffer 1	3s
09	Wait	60 s
10	Cal. Buffer 1	15s
11	Water	60 s
12	Compressed air	20s
13	Assembly measuring	
14		
15	(up to 28 program steps possible)	

Configuration menu



To call the menu, select:

" > Specialist > Set up 2 > Topcal"

Function	Options	Info
<p>Select function</p>	<p>Options</p> <ul style="list-style-type: none"> ■ Setup Topcal ■ Activate Topcal <p>Factory setting Setup Topcal</p>	<p>Setup: Create or edit a Topcal program. Activate: Switch Topcal functions on or off.</p>
Configuration		
Note	Automatic: Off Clean trigger: Off Ext. control: Off	Current system status
Valve name V1 (or V2)	0 ... 9; A ... Z Factory setting Valve 1 (or 2)	You can enter names up to eight characters in length for the additional valves. These names are automatically accepted with the program steps.

Function	Options	Info
Function of the cleaning system	Options <ul style="list-style-type: none"> ■ Automatic ■ Interval program ■ Cleaning ■ Pwrfail prog. ■ Prog. editor Factory setting Automatic	Select Program editor to adapt the cleaning or calibration programs to your needs or select a control type you want to assign a program to. Automatic: Weekly program that starts the selected cleaning or calibration program at the set times. Interval program: Program that starts at defined intervals. Cleaning: Program that is started if the sensor is fouled or clogged (SCS). Power failure program: Program that is automatically started after a power supply or communication failure. Prog. editor: Adapt the cleaning and calibration programs to your needs and preferences.
Program editor		
Select program	Options <ul style="list-style-type: none"> ■ Clean ■ Clean C ■ Clean S ■ Clean CS ■ User 1 ■ User 2 ■ User 3 Factory setting Clean	Select the program you want to edit.
Select the editing function	Options <ul style="list-style-type: none"> ■ Insert prog. ■ Edit ■ Setup ■ Prog.time ■ Change name Factory setting Insert prog.	Select the desired editing function. Insert progr.: You can insert a predefined program into the selected program. Edit: You can add or delete program steps. Setup: You can set the times and repeat cycles of the selected program. Prog.time: The total duration of the selected program is displayed. Change name: You can give the selected program any name of your choice.
Insert prog.		
Select template	Options <ul style="list-style-type: none"> ■ No prog. ■ Clean ■ Clean S ■ Clean C ■ Clean CS ■ User 1 ■ User 2 ■ User 3 Factory setting No prog.	Select the template that is to be copied into the selected program.
Edit		
Select rows	Options <ul style="list-style-type: none"> ■ 01 ■ 02 ... Factory setting 01	Select the line you want to edit.

Function	Options	Info
Edit line	Options <ul style="list-style-type: none"> ■ Change ■ Delete ■ Move to ■ Insert 	Select the editing function for the selected line. Edit: The function for the selected item is changed, e.g. "Water" changed to "Cleaner". Delete: The selected function is deleted (you are not asked to confirm you really want to delete) Move to: The selected function is moved to another position. Insert: A new item is inserted ahead of the selected item. For Insert/Edit , all possible program steps are displayed, e.g. Valve 1 open, Valve 1 close, Water, Cleaner etc.
Setup		
Adapting program steps	Options <ul style="list-style-type: none"> ■ Water 0 s ■ Cleaner 0 s ■ Wait 0 s ...	Select the program step you want to adapt.
Enter values	0 ... 9999 s 0x (dependent on the selected program step)	Enter the desired value for the selected program step. Cleaner / Buffer 1, 2: Enter the time as to how long the cleaner/buffer should be pumped. The minimum pump time is 3 seconds. Wait: Enter the time as to how long the system should remain in its current state. Back to: Enter the number of repeats a loop should run through. Air: Enter the time as to how long compressed air should flow.
Prog.time		
Prog.time	0 ... 9999 s	The total duration of the selected program is displayed here. The display cannot be edited.
Change name		
Change name	0 ... 9; A ... Z	You can enter any name for the selected program.
Automatic		
Select day	Options <ul style="list-style-type: none"> ■ Monday ■ Wednesday ■ Thursday ■ Friday ■ Saturday ■ Sunday Factory setting Monday	Select the day you want to edit.
Select the editing function for the day	Options <ul style="list-style-type: none"> ■ Edit day ■ Copy day Factory setting Edit day	Edit day: You edit the cleaning cycle for the selected day. Copy day: The day selected in the previous field is copied to the day you select in the following field.

Function	Options	Info
Edit day		
Select programs	Activation and subsequent entry <ul style="list-style-type: none"> ■ Clean 18:22 18:23 ■ Interval 18:24 18:54 ■ No prog. Factory setting No prog.	Select the cleaning programs for the day and enter the times for the start of cleaning. If you select the interval program, also enter the time for stopping the cleaning. The time for start and end is always shown. Example: Clean 18:22 (start time) 18:23 (end time)  Note! 10 program starts are possible each day.
Copy day		
Select day	Options <ul style="list-style-type: none"> ■ Tuesday ■ Wednesday ■ Thursday ■ Friday ■ Saturday ■ Sunday Factory setting Tuesday	Select the day to which you want to copy the day previously selected (e.g. Monday).  Note! Danger of data loss. When copying one day to another, the cleaning programs of the target day are overwritten.
Interval program		
Select program Enter interval	Activation and subsequent entry <ul style="list-style-type: none"> ■ Program <ul style="list-style-type: none"> – Clean – Clean C – Clean S – Clean CS – User 1 – User 2 – User 3 ■ Interval 0 ... 36000 s Factory setting Program: Clean Interval: 3600 s	Program: Select the program that should be started at the defined intervals. Interval: Enter the time that should elapse between the end of one program cycle and the start of the next program cycle.  Note! Enter an interval of at least 10 minutes here so that the program cycles can be ended and started correctly.
Change name	0 ... 9; A ... Z	You can enter any name for the interval program.
Cleaning		
Select program	Options <ul style="list-style-type: none"> ■ No prog. ■ Clean ■ Clean C ■ Clean CS ■ Clean S ■ User prog. Factory setting No prog.	Select the program that should be started if the electrode is fouled or clogged.

Function	Options	Info
Power failure program		
Note	The selected program is started after a network communication or air supply failure	
Select program	<p>Options</p> <ul style="list-style-type: none"> ■ No prog. ■ Clean ■ Clean C ■ Clean CS ■ Clean S ■ User prog. <p>Factory setting Clean</p>	Select the program that should be started if the network communication or air supply fails.
Activate Topcal		
Activate control programs	<p>Activation and subsequent selection</p> <ul style="list-style-type: none"> ■ Automatic <ul style="list-style-type: none"> – On – Off ■ Ext. control <ul style="list-style-type: none"> – On – Off ■ Clean trigger <ul style="list-style-type: none"> – On – Off ■ Power reset <ul style="list-style-type: none"> – On – Off 	Activate the control programs via which a program should be started.
Activate back pressure water (sealing water)	<p>Activation and subsequent selection</p> <ul style="list-style-type: none"> ■ Function <ul style="list-style-type: none"> – On – Off ■ Relay <ul style="list-style-type: none"> – Water – Valve 1 – Valve 2 ■ Length: 01 ... 30 s <p>Factory setting Function: On Relay: Water Length: 05 s</p>	<p>Specify whether and when sealing water should be pumped.</p> <p>Sealing water is pumped into the rinse chamber before and after moving the assembly. This is useful in processes with media that are fibrous or tend to stick as the counterpressure in the rinse chamber caused by the sealing water prevents the penetration of medium.</p> <p>Function: If you activate the function, sealing water is pumped into the rinse chamber of the assembly every time the assembly is moved.</p> <p>Relay: Specify via which valve the sealing water should be pumped in.</p> <ul style="list-style-type: none"> ■ Water: Via the water connection at the rinsing block ■ Valve 1, Valve 2: Via additional valve 1 or 2 <p>Length: Specify how long sealing water should be pumped before and after moving the assembly.</p>

7.6.17 Set up 2 - Chemoclean

Chemoclean is a system for automatic sensor cleaning. Water and cleaner are pumped to the sensor via the injector (e.g. CYR10) by means of two contacts.

Use with Topcal S

Chemoclean is a standard Mycom S function and can also be used in conjunction with Topcal S. The two contacts can be started as follows in Mycom S:

- Externally, via a binary input in Mycom S
- In a weekly pattern (automatic)
- By means of manual operation

The two contacts can be flexibly adapted to individual cleaning cycles by means of a user-defined program.

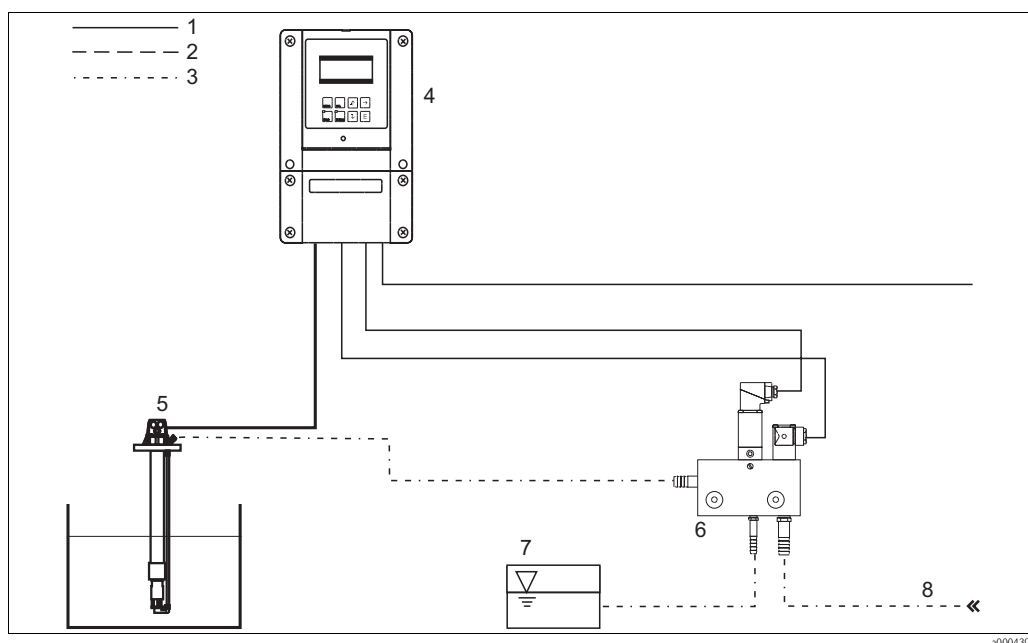

Fig. 57: Chemoclean cleaning

- | | | | |
|---|-----------------------|---|--------------------|
| 1 | Electric cable | 5 | Immersion assembly |
| 2 | Compressed air | 6 | CYR10 injector |
| 3 | Water/cleaning liquid | 7 | Cleaning liquid |
| 4 | Mycom S transmitter | 8 | Motive water |

Operation

1. In the "Set up 1 - Relays" menu, switch the Chemoclean function on. Make sure that the corresponding contacts are connected to the injector (see connection examples in the appendix).
2. The cleaning cycles are configured in the "Set up 2 - Chemoclean" menu. Here, the automatic or event-controlled cleaning can be adapted to the process conditions. One or more of the following controls are possible:
 - Weekly program (see below): As many cleaning cycles as required can be started on every weekday.
 - External control: A start can be triggered by means of the digital inputs. For this purpose, the external controller has to be activated in the "Select contr. progr." field: Ext. control "On".
 - Power failure: Cleaning is started after a power failure.

Manual operation

Rapid onsite cleaning can be performed by means of manual operation. Select  > Manual operation > Chemoclean" for this purpose. Press  twice ("Start cleaning").

Automatic programming:

You can program every day individually. Select "PARAM > Set up 2 > Chemoclean > Automatic" for this purpose:

The following programs are available:

- Clean: Cleaning start by entering the start time.
- Interval program: Cleaning takes place at defined intervals. This program cannot be triggered directly by means of the binary inputs.
- User: User-defined cleaning programs (create in the program editor).

Program cycles

Monday: Clean x 2 (at 11:00 and at 18:00) with water for 120 s, 60 s of which also with cleaner. Between 18:20 and 24:00, clean every 30 min. (= 1800 s) with water for 120 s, 60 s of which also with cleaner.

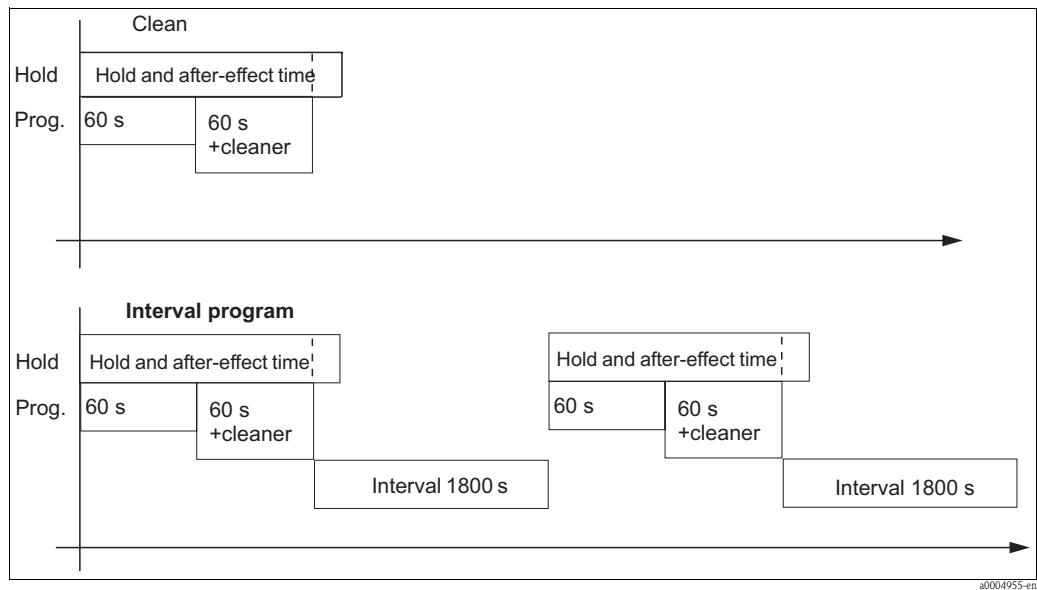

Fig. 58: Graphic representation of the above example

Necessary settings as per the example (bold: to be entered by the user):

"Automatic > Weekday > Edit day" field		"Edit prog. > Clean > Setup" field		"Interval program" field	
Clean		01 Water	60 s	Program	Clean
11:00	11:02	02 +Cleaner	60 s	Interval	1800 s
Clean		03 Water	0 s		
18:00	18:02	04 rep. clean.	0x		
Interval program					
18:20	23:59				

Chemoclean menu

To call the menu, select:

"PARAM" > Specialist > Set up 2 > Chemoclean"

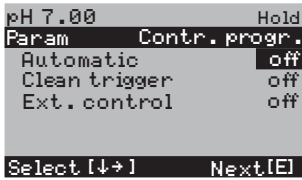
Function	Options	Info
Contr.progr. 	Activation and subsequent entry <ul style="list-style-type: none"> ■ Automatic <ul style="list-style-type: none"> - On - Off ■ Clean trigger <ul style="list-style-type: none"> - On - Off ■ Ext. control <ul style="list-style-type: none"> - On - Off Factory setting Automatic: Off Clean trigger: Off Ext. control: Off	Select the function that should trigger Chemoclean cleaning.
Note	Automatic: Off Clean trigger: Off Ext. control: Off	Current system status
Configuration menu	Options <ul style="list-style-type: none"> ■ Automatic ■ Interval program ■ Edit prog. Factory setting Automatic	Select the configuration menu. Automatic: You can select cleaning programs for every weekday here. Interval program: Program that starts at defined intervals. Edit prog.: You can adapt the cleaning programs to your needs and preferences here.
Edit program		
Select program	Options <ul style="list-style-type: none"> ■ Clean ■ User prog. 	Select the program you want to edit.
Select the editing function	Options <ul style="list-style-type: none"> ■ Insert prog. ■ Edit ■ Setup ■ Prog.time ■ Change name Factory setting Insert prog.	Select the desired editing function. Insert progr.: You can insert a predefined program into the selected program. Edit: You can add, change or delete program steps. Setup: You can set the times and repeat cycles of the selected program. Prog.time: The total duration of the selected program is displayed. Change name: You can give the selected program any name of your choice.
Insert program		
Select template	Options <ul style="list-style-type: none"> ■ No prog. ■ Clean ■ User Factory setting No prog.	Select the template that is to be copied into the user program.
Edit		
Select rows	Options <ul style="list-style-type: none"> ■ 01 ■ 02 ... Factory setting 01	Select the row you want to edit.





Function	Options	Info
Edit line	Options <ul style="list-style-type: none"> ■ Change ■ Delete ■ Move to ■ Insert 	Select the editing function for the selected line. Edit: The function for the selected item is changed, e.g. "Water" changed to "W.+Cleaner". Delete: The selected function is deleted (you are not asked to confirm you really want to delete) Move to: The selected function is moved to another position. Insert: A new item is inserted ahead of the selected item.
Setup		
Adjusting program steps	Options <ul style="list-style-type: none"> ■ Water 0 s ■ W.+clean. 0 s ... 	Select the program step you want to adjust.
Enter values	0 ... 9999 s 0x (depending on the selected program step)	Enter the desired value for the selected program step. Cleaner / Water: Specify the time as to how long the cleaner/water should be pumped. Wait: Enter the time as to how long the system should remain in its current state. Back to: Enter the number of repeats a loop should run through.
Program time		
Prog.time	0 ... 9999 s	The total duration of the selected program is displayed here. The display cannot be edited.
Rename		
Change name	0 ... 9; A ... Z	Enter a new name for the user program.
Automatic		
Select day	Options <ul style="list-style-type: none"> ■ Monday ■ Wednesday ■ Thursday ■ Friday ■ Saturday ■ Sunday Factory setting Monday	Select the day you want to edit.
Select the editing function for the day	Options <ul style="list-style-type: none"> ■ Edit day ■ Copy day Factory setting Edit day	Edit day: You edit the cleaning cycle for the selected day. Copy day: The day selected in the previous field is copied to the day you select in the following field.
Edit day		
Select programs	Activation and subsequent entry <ul style="list-style-type: none"> ■ No prog. ■ Clean 18:22 18:23 ■ Interval 18:24 18:54 Factory setting No prog.	Select the cleaning programs for the day and enter the times for the start of cleaning. If you are using the interval program, also enter the time for stopping the cleaning. The time for start and end is always shown. Example: Clean 18:22 (start time) 18:23 (end time)

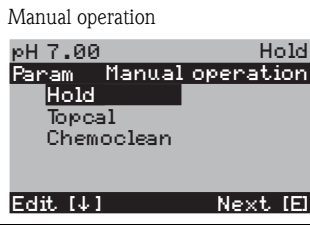

Function	Options	Info
Copy day		
Select day	Options <ul style="list-style-type: none"> ■ Tuesday ■ Wednesday ■ Thursday ... Factory setting Tuesday	Select the day to which you want to copy the day previously selected (e.g. Monday).  Note! Danger of data loss. When copying one day to another, the cleaning programs of the target day are overwritten.
Interval program		
Select program Enter interval	Activation and subsequent entry <ul style="list-style-type: none"> ■ Program <ul style="list-style-type: none"> – Clean – User prog. ■ Interval <ul style="list-style-type: none"> 0 ... 36000 s Factory setting Program: Clean Interval: 3600 s	Program: Select the program that should be started at the defined intervals. Interval: Enter the time that should elapse between the end of one program cycle and the start of the next program cycle.
Change name	0 ... 9; A ... Z	You can enter any name for the interval program.

7.6.18 Manual operation

To call the menu, select:







" > Specialist > Manual operation"

Function	Options	Info
Manual operation 	Options <ul style="list-style-type: none"> ■ Hold ■ Topcal ■ ChemoClean 	You can activate a manual hold and start the Chemoclean or Topcal program. The settings you make here are only active in this menu. Nothing is saved when you leave. You exit the manual operation menu with  ,  or  .
Hold		
Activate hold	Options <ul style="list-style-type: none"> ■ Hold on ■ Hold off Factory setting Hold off	Activate/deactivate the HOLD. The "HOLD" function freezes the current outputs as soon as cleaning/calibration is undertaken.  Note! If the controller function is set to current output 2, this output obeys the defined "controller hold" (see also "Set up 1 - Hold" section).
Topcal		
Note	Automatic off Cleaning trigger off Ext. control off	Displays the status of the system.
Select function	Options <ul style="list-style-type: none"> ■ Retract assembly ■ Start program ■ Stop program 	You can move the assembly manually or stop/start a program.

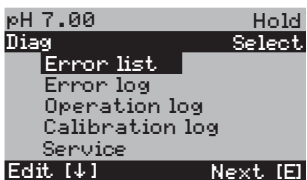

Function	Options	Info
Retract assembly		
Select position	Options <ul style="list-style-type: none"> ■ Assembly service ■ Assembly measuring 	Select the position to which the assembly should move.
Note	Automatic off Cleaning trigger off Ext. control off	Displays the status of the system.
Start program		
Select program	Options <ul style="list-style-type: none"> ■ No prog. ■ Clean ■ Clean C ■ Clean S ■ Clean CS ■ User prog. 1 ... 3 	Select the program you want to start. If a program is already running, the new program is not started until the program running is completed.
Note	Automatic off Cleaning trigger off Ext. control off Clean running Water 10 s Cleaner 3 s	The status of the system is displayed. The program currently running is displayed with the time remaining for water, cleaner etc.
Stop program		
Note	Automatic off Cleaning trigger off Ext. control off	The running program is stopped. The status of the system is displayed.
Chemoclean		
Note	Automatic: Off Clean trigger: Off Ext. control: Off	System status
Chemoclean cleaning	Options <ul style="list-style-type: none"> ■ No prog. ■ Clean Factory setting No prog.	No prog.: Every external program start is suppressed here. Clean: You can start the Clean program here.  Note! Exit this menu item with  .

7.7 Diagnosis

To call the menu, press .

Function	Options	Info
Diagnosis 	Options <ul style="list-style-type: none"> ■ Error list ■ Error log ■ Operation log ■ Calibration log ■ Validate log ■ Ext. sensor data (only for digital sensors with Memosens technology) ■ Service 	<p>Error list: Displays the error currently active. (Complete error list with description, see the "Troubleshooting" section).</p> <p>Error log: Lists the 30 errors last reported with date and time.</p> <p>Operation log: Lists the 30 operating steps last registered with date and time.</p> <p>Calibration log: Lists the last 30 calibrations performed with date and time.</p> <p>Validate log: Lists the last 30 Topcal validations.</p> <p>Ext. sensor data: Lists the data saved in the sensor, e.g. sensor identification, calibration data, hours of operation etc.</p> <p> Note!</p> <ul style="list-style-type: none"> ■ Use the arrow keys to scroll through the lists. ■ Exit the lists with .
Calibration log		
Calibration data	<ul style="list-style-type: none"> ■ 1 data input ■ Zero point ■ Slope ■ El. condition ■ <Date> <time> 	<p>1 data input Displays the calibration method used.</p> <p>Zeropoint: Displays the zero point calculated during calibration.</p> <p>Slope: Displays the slope calculated during calibration.</p> <p>Electr. condition: Displays the electrode condition.</p> <p><Date> <time>: Displays the date and time of the calibration.</p>
If you are using a digital sensor with Memosens functionality, you get the following information after pressing  :		
	<ul style="list-style-type: none"> ■ SNR ■ Sensor change date ■ <Date> <time> 	Displays the serial number of the calibrated sensor and the date and time of the sensor change.
<p>Ext. sensor data (only for sensors with Memosens technology)</p> <p>The transmitter indicates that the sensor data are being read out. The display automatically switches on completion of the read-out process.</p> <p>If the system does not automatically continue, you can call up the data last read out by pressing  or return to measuring operation by pressing .</p>		
Data of the digital sensor	Options <ul style="list-style-type: none"> ■ Identification ■ Calibration data ■ Comp. temperature ■ Sensor status ■ Sensor info 	Select the data saved in the digital sensor which are to be displayed.
Identification		
Manufacturer data	<ul style="list-style-type: none"> ■ ID ■ SW ID ■ HW version ■ SW version 	<p>ID: Displays the module ID of the sensor.</p> <p>SW ID: Displays the software ID of the sensor.</p> <p>HW version: Displays the hardware version of the digital sensor.</p> <p>SW version: Displays the software version of the digital sensor.</p>
	<ul style="list-style-type: none"> ■ Check date ■ SAP ■ SN 	<p>Check date: Indicates when the factory test of the sensor was carried out.</p> <p>SAP: Displays the SAP number of the sensor.</p> <p>SN: Displays the serial number of the sensor electronics.</p>

Function	Options	Info
Calibration data		
	<p>pH:</p> <ul style="list-style-type: none"> ■ Slope ■ Isoth. point <ul style="list-style-type: none"> – pH – mV ■ C-zero pnt <p>Redox:</p> <ul style="list-style-type: none"> ■ Offset ■ Buffer ■ D. Ist. Cl. 	<p>Slope: Displays the slope of the sensor. Isoth. point: Displays the mV and pH component of the isotherm intersection. C-zero pnt: Displays the chain zero point of the digital sensor. Offset: Displays the calibrated redox offset. Buffer: Displays the value of the buffer. D.Ist. cal.: Displays the difference to the last calibration.</p>
	<ul style="list-style-type: none"> ■ Method ■ No. of cal. ■ Snlc ■ Calibration date 	<p>Method: Indicates the method that was used to calibrate the digital sensor. Select the calibration method in the "Set up 1 > Calibration" menu. No. of cal.: Indicates the number of calibrations carried out with the digital sensor. Snlc: Displays the serial number of the transmitter with which the last calibration was performed. Cal. Date: Displays the date of the last calibration of the digital sensor.</p>
	<ul style="list-style-type: none"> ■ Buffer 1 ■ Buffer 2 ■ D. slp ■ D. zropnt 	<p>Only available for digital pH sensors. Buffer 1: Displays the pH value of the first buffer that was used in the last calibration. Buffer 2: Displays the pH value of the second buffer that was used in the last calibration. D. slp: Displays the change in the slope compared to the earlier calibration. D. zropnt: Displays the change in the chain zero point compared to the earlier calibration.</p>
Comp. temperature		
Temperature offset	<ul style="list-style-type: none"> ■ Offset ■ Snlc ■ Calibration date 	<p>Offset: Displays the calibrated temperature offset. Snlc: Displays the serial number of the transmitter with which the last temperature calibration was performed. Cal. date: Displays the date of the last temperature calibration.</p>
Sensor condition		
	<ul style="list-style-type: none"> ■ Period ■ No. of steril. ■ T (max) 	<p>Period: Displays the total hours of operation of the sensor. No. of steril.: Displays the number of sterilizations the sensor has run through: T > 121 °C (250 °F), at least 20 min. T (max): Displays the maximum temperature the sensor has been used at.</p> <p> Note! During a sterilization (T > 135 °C (275 °F)), the transmitter goes to Hold and the display shows "SIP" (sterilization in place).</p>
	<p>Time of operation (h)</p> <ul style="list-style-type: none"> ■ Over 80 °C ■ Over 100 °C ■ <- 300 mV (only pH) ■ > 300 mV (only pH) 	<p>Time of operation of the sensor under the following conditions:</p> <ul style="list-style-type: none"> ■ Operating hours of the sensor at temperatures over 80 °C (176 °F) ■ Operating hours of the sensor at temperatures over 100 °C (212 °F) ■ Operating hours of the sensor at a pH value below -300 mV (= pH 12 @ 25 °C (77 °F)) ■ Operating hours of the sensor at a pH value over +300 mV (= pH 2 @ 25 °C (77 °F))

Function	Options	Info
	<ul style="list-style-type: none"> ■ 1st use ■ Ri GSCS (only pH) 	<p>1st use: Indicates when the sensor was connected to a transmitter for the first time.</p> <p>Ri GSCS: Displays the current membrane resistance.</p>
Sensor info		
Application	<ul style="list-style-type: none"> ■ Max. rng. ■ Min. rng. ■ Max. temp. ■ Min. temp. 	<p>Max. rng.: Maximum measured value in the sensor application range</p> <p>Min. rng.: Minimum measured value in the sensor application range</p> <p>Max. temp.: Maximum temperature in the sensor application range</p> <p>Min. temp.: Minimum temperature in the sensor application range</p>
Order data	<ul style="list-style-type: none"> ■ Order Code ■ OVSN ■ Check date 	<p>Order code: Order code of the sensor</p> <p>OVSN: Overall serial number of the</p> <p>Check date: Indicates when the factory test of the sensor was carried out.</p>
Service		
Service diagnosis	<p>Options</p> <ul style="list-style-type: none"> ■ Factory reset ■ Simulation ■ Instrument check ■ DAT download ■ Set up 2 ■ Instrument version ■ Topcal ■ Chemoclean ■ Reset count 	<p>Factory reset: Various data groups can be reset to the factory setting.</p> <p>Simulation: The behavior of the transmitter can be simulated after a number of parameters have been entered.</p> <p>Instrument check: The instrument functions (display, keys,...) can be tested individually.</p> <p>DAT download: Copy data from/into the DAT module.</p> <p>Set up 2: ISFET values and SCS values</p> <p>Instrument version: Device-internal data, e.g. the serial number, can be queried.</p> <p>Topcal S: Test programs, inputs, hardware.</p> <p>Chemoclean (only if the complete Chemoclean function is activated): Test programs, inputs, hardware.</p> <p>Reset count: Counter for the number of resets and write access</p>
Factory reset		
Set default	<p>Options</p> <ul style="list-style-type: none"> ■ Abort ■ Only start-up data ■ Only calibration data ■ Complete reset ■ CPC data ■ Service data ■ Operation log ■ Error log ■ Calibration log 	<p>Here you select the data which you wish to reset to the factory settings.</p> <p> Note! Danger of data loss. Selecting a point and confirming with  deletes the settings you made in this area! Pressing Cancel leaves this field without changing the values.</p> <p>Only calibration data: All the data saved with calibrations such as zero point, slope, and offset.</p> <p>Only start-up data: The remaining data to be set</p> <p>Complete reset: Calibration data + setting data</p> <p>CPC data: Topcal configuration, e.g. cycles of cleaning and calibration programs</p> <p>Service data: All data + logs + reset counters</p> <p> Note! Service data / logbooks: These functions are only for authorized service personnel. The service code is required. You can request the service code from Endress+Hauser.</p>

Function	Options	Info
Simulation		
Simulation of current outputs	Activation and subsequent entry <ul style="list-style-type: none"> ■ Simulation <ul style="list-style-type: none"> - On - Off ■ Output 1 <ul style="list-style-type: none"> 0.0 ... 22.0 mA ■ Output 2 <ul style="list-style-type: none"> 0.0 ... 22.0 mA Factory setting Simulation: Off Output 1: 0.0 mA Output 2: 0.0 mA	Adjust the simulation of the current outputs. Simulation off: The frozen values of the last measurement are used for simulation. Simulation on: The current values for the outputs can be altered for the simulation (output 1, output 2).
Simulation of measured value, temperature	Activation and subsequent entry <ul style="list-style-type: none"> ■ Simulation <ul style="list-style-type: none"> - On - Off ■ pH/mV 1 <ul style="list-style-type: none"> -2.00 ... 16.00 pH ■ Temperature <ul style="list-style-type: none"> -50 ... +150 °C Factory setting Simulation: Off pH/mV 1: 7.00 pH Temperature: 25.0 °C	Adjust the simulation of measured values and the temperature. Simulation off: The frozen values of the last measurement are used for simulation. Simulation on: The values can be changed for the simulation.
Simulation of relays	Activation and subsequent entry <ul style="list-style-type: none"> ■ Simulation <ul style="list-style-type: none"> - On - Off ■ Alarm relay <ul style="list-style-type: none"> - On - Off ■ Relay 1 <ul style="list-style-type: none"> - On - Off ■ Relay 2 <ul style="list-style-type: none"> - On - Off Factory setting Simulation: Off Alarm relay: Off Relay 1/2: Off	Adjust the simulation of the relays. Simulation off: The last states are frozen and used for simulation. Simulation on: The relays can be opened (on) or closed (off).  Note! If you return to the measurement mode with the simulation switched on, "Simul" and "Hold" flash in the display.
Instrument check		
Select test	Options <ul style="list-style-type: none"> ■ Display ■ Keypad ■ RAM ■ EEPROM ■ Flash 	You can check the function of the transmitter with the instrument check. Display: All the fields of the display are addressed alternately. In this way, any defective cells are visible. Key pad: The keys all have to be pressed one after the other. If the system is functioning perfectly, the appropriate symbols appear in the display. RAM: "RAM o.k." message if operating correctly without error. EEPROM: "EEPROM o.k." message if operating correctly without error. Flash (memory): "Flash o.k." message if operating correctly without error.

Function	Options	Info
DAT download (only available if the DAT module is connected)		
DAT process	Options <ul style="list-style-type: none"> ■ DAT write ■ DAT read ■ Erase DAT 	Select the desired DAT process DAT write: You save the configuration and the logbooks of your transmitter to the DAT memory module. A security message is issued stating that all the data on the DAT will be overwritten. After confirming, the process of backing up to the DAT memory module is started. DAT read: You copy the configuration that is saved on the DAT memory module to the EEPROM in the transmitter. A security message is issued stating that all the data in the transmitter will be overwritten. After confirming, the process of copying from the DAT memory module is started. Erase DAT: You delete all the data on the DAT memory module. A security message is issued stating that all the data on the DAT will be erased. The data are erased after confirming.
Set up 2		
Select Set up 2	Options <ul style="list-style-type: none"> ■ Reset ■ ISFET (only with ISFET sensors) ■ SCS reading 	Display sensor data. ISFET: Displays the current ISFET sensor data <ul style="list-style-type: none"> ■ Reference [mV] ■ Leak current [µA] SCS reading: Displays the current values of the sensor check system SCS <ul style="list-style-type: none"> ■ Impedance of glass electrode [MΩ] ■ Impedance of reference electrode [kΩ]
Instrument version		
Controller	<ul style="list-style-type: none"> ■ SW version 1.20-xx ■ HW version 1.00 ■ Serial No.: 12345678 ■ Card ID M3Cxxx 	You can call up the controller data here. The software version refers to the current device overall software.
Motherboard	<ul style="list-style-type: none"> ■ SW version ---- ■ HW version 1.00 ■ Serial No.: 12345678 ■ Card ID M3G-xx ■ Non-Ex 	You can call up the motherboard data here.
Connector PCB	<ul style="list-style-type: none"> ■ SW version ---- ■ HW version 1.04 ■ Serial No.: 12345678 ■ Card ID M3K-xx 	You can call up the connector PCB data here.

Function	Options	Info
Transmitter	<ul style="list-style-type: none"> ■ SW version 1.22 ■ HW version 1.11 ■ Serial No.: 12345678 ■ Card ID MKPx ■ Ex 	You can call up the transmitter module data here.
Relay	<ul style="list-style-type: none"> ■ SW version ---- ■ HW version 1.00 ■ Serial No.: 12345678 ■ Card ID M3R-xx ■ Ex 	You can call up the relay module data here.
Sensor	<ul style="list-style-type: none"> ■ SW version 1.20 ■ HW version 1.00 ■ Serial No.: 12345678 ■ ID A1B ■ SW-ID D1C ■ Check date xx.xx.xx 	You can call up the sensor data here if you are using digital sensors with Memosens technology.
Serial number for Mycom S	123A567890Z234	You can call up the serial number of the device here; 14-digit number with digits 0 ... 9 and A ... Z.
Order code for Mycom S	CPM153-A2B00A010	You can call up the order code of the device here; 15-digit code with digits 0 ... 9 and A ... Z.
CPC data	<ul style="list-style-type: none"> ■ SW version 1.20 ■ HW version 1.00 ■ Serial No.: 12345678 ■ Card ID CPGxxx 	You can call up the control unit data here.
Serial number for CPG310	12345678901234	You can call up the serial number of the control unit here; 14-digit number with digits 0 ... 9 and A ... Z.
Order code for Topcal S	CPC310-A011B0A000A	You can call up the order code of the device here; 15-digit code with digits 0 ... 9 and A ... Z.
Topcal S		
Note	Automatic off Cleaning trigger off Ext. control off	Displays the status of the system.
Integral part for diagnosis	Options <ul style="list-style-type: none"> ■ Ext. inputs ■ Hardware 	Select the integral part of the system whose status you want to check or change.

Function	Options	Info
Ext. inputs		
Note	Start no prog. AutoStop off Wait trigger off Ass. measuring off Ass. service off	The status of the external digital inputs is displayed.
Hardware		
Valve test	Options <ul style="list-style-type: none"> ■ Assembly ■ Cleaner ■ Water ■ Buffer 1 ■ Buffer 2 ■ Compressed air ■ Valve 1 ■ Valve 2 	Select the components that should be tested.
Note	Assembly ↑ Service End function Topcal S ready	The component selected previously is tested.
Chemoclean		
Note	Automatic: Off Clean trigger: Off Ext. control: Off	The status of the system is displayed.
Note	With E running program is aborted.	If a Chemoclean program is currently running, you have to abort the program with <input type="button" value="E"/> to be able to perform the diagnosis.
Chemoclean diagnosis	Options <ul style="list-style-type: none"> ■ Ext. inputs ■ Hardware 	Ext. inputs: The status of the external digital inputs is displayed. Hardware: Select a function that should be tested: <ul style="list-style-type: none"> ■ Water ■ Cleaner ■ Water and cleaner
Reset count		
Reset counter	0	The number of resets is called up here. The reset counter is only triggered by the watchdog. You can reset it via "Set default > Service data".
Write counter	0	The number of writes to the EEPROM is called up here.

7.8 Calibration

Calibration is required:

- After replacing the electrode
- After periods of standstill (note: a pH glass electrode must not be stored dry!)
- At suitable intervals, depending on the process in question. The necessary interval can range from several times a day to once a quarter. At the start, calibrate more frequently and record the results in the operating logbook. The data of the last 30 calibrations are also stored in the calibration log. Gradually extend the intervals depending on the deviations that are recorded with calibration.

The calibration can be protected with the maintenance and the specialist codes. Calibration cannot take place on the read-only level (see the "Set up 1 - Access codes" section for this purpose).

Procedure

1. If you have not made any initial settings for local calibration, please make them in the  > Set up 1 > Calibration" menu.
2. Set the service switch to "Service" (vertical) or move the assembly into the Service position
3. Remove the sensor.
4. Clean the sensor before calibration.



Note!

- When measuring with PM (potential matching), the PM line also has to be immersed in the buffer solution.
- If automatic temperature compensation is selected for calibration (ATC), the corresponding temperature sensor must also be immersed in the buffer solution.
- The instrument switches automatically to Hold (factory setting) whenever it is calibrated.
- Press  to cancel the calibration. In the dialog field that follows, select "Yes, abort cal.".

The following section describes the calibration cycles for:

Calibration pH

- "Manual data input"
- "Cal with manual buffer"
- "Cal with buffer table"
- "Cal with automatic buffer recognition"

Calibration, redox absolute

- "Data input absolute"
- "Calibration, absolute"





Calibration, redox relative

- "Data input absolute"
- "Data input relative"
- "Calibration, absolute"
- Calibration, relative

7.8.1 Calibration pH

Manual data entry

The values for sensor zero point and slope are entered manually.
Press  to start calibration.

Function	Options	Info
Note	Calibration with enter spec. buffer	The type of local calibration selected in the calibration settings is displayed.
Temperature	-20.0 ... 150.0 °C Factory setting 25.0 °C	Specify the temperature at which calibration takes place (only for "Cal with MTC"). Confirm with  .
Zero point	-2.00 ... 16.00 pH Factory setting 7.00 pH	Enter the zero point of the electrode. Confirm with  .
Slope	5.00 ... 99.00 mV / pH Factory setting 59.16 mV/pH	Enter the slope of the electrode. Confirm with  .
Calibration	Options <ul style="list-style-type: none"> ■ Accept ■ Cancel ■ Repeat calibration 	Ending calibration Accept: When you confirm with  , the new calibration data are accepted. Cancel: The data are not accepted. Calibration is not repeated. Repeat calibration: The data are rejected and calibration is repeated.
Sensor communication	Waiting for sensor response ...	(only available for digital sensors with Memosens technology.) The transmitter transmits calibration data to the sensor.
Note	<ul style="list-style-type: none"> ■ Data saved ■ Data NOT saved 	(only available for digital sensors with Memosens technology.) Indicates whether the calibration data could be saved in the sensor. Calibrate the sensor again if the process of saving the data failed.
Note	Electrode in medium?	Ensure that the electrode is in the medium again so measuring can take place.

Calibration with manual buffer, calibration with buffer table, calibration with automatic buffer recognition

- **Manual buffer:**
The buffer pH value is entered manually. The display then shows the current measured value.
- **Buffer table:**
In the calibration menu, specify two buffer solutions or define yourself. The selected pH value and buffer type are displayed.
- **Automatic buffer recognition:**
The device automatically recognizes the used buffer. Preselect the buffer types (e.g. E+H) in the calibration menu.

Press  to start calibration.

Function	Options	Info
Note	Calibration with manual buffer, (with buffer table/automatic buffer recognition)	The type of local calibration selected in the calibration settings is displayed.
Temperature	-20.0 ... 150.0 °C Factory setting 25.0 °C	Specify the temperature at which calibration takes place (only for "Cal with MTC"). Confirm with  .



Function	Options	Info
Buffer temperature	-20.0 ... 150.0 °C Factory setting 25.0 °C	Enter the buffer temperature (only for "Cal with MTC"). Confirm with <input type="button" value="E"/> .
Handling instructions	Immerse: pH electrode in buffer 1	Immerse the electrode in buffer 1. Confirm with <input type="button" value="E"/> .
pH value buffer	-2.00 ... 16.00 pH Factory setting 7.00 pH	Only for "Manual buffer". Enter the buffer pH value of buffer 1. Confirm with <input type="button" value="E"/> .
Stability check	<ul style="list-style-type: none"> ■ Time: 10 s ■ pH 1: 7.00 ■ mV 1: 0 ■ °C: 25.0 	<p>Wait until the pH measurement is stable: Time no longer counts. pH value no longer flashes. mV value no longer flashes. Once these values are stable, confirm with <input type="button" value="E"/>.</p> <p> Note! Specify the criteria for the stability check in the "Set up 1 > Calibration > Cal settings" menu.</p>
The three previous steps are carried out for buffer 2.		
Calibration value notice	Invalid calibration value	This message is displayed if an error is present (e.g. wrong buffer used).
Zero point, slope notice	<ul style="list-style-type: none"> ■ Zeropoint: 7.00 Good ■ Slope: 59.00 Good 	Information on the zero point, slope and quality of the calibration is displayed here.
Electrode condition notice	Electr. condition: Good	There are three status messages for the electrode status: "good", "OK.", "bad". If the status is displayed "bad", electrode replacement is recommended to ensure the quality of the pH measurement.
Calibration	Options <ul style="list-style-type: none"> ■ Accept ■ Cancel ■ Repeat calibration 	Ending calibration Accept: When you confirm with <input type="button" value="E"/> , the new calibration data are accepted. Cancel: The data are not accepted. Calibration is not repeated. Repeat calibration: The data are rejected and calibration is repeated.
Sensor communication	Waiting for sensor response ...	(only available for digital sensors with Memosens technology.) The transmitter transmits calibration data to the sensor.
Note	<ul style="list-style-type: none"> ■ Data saved ■ Data NOT saved 	(only available for digital sensors with Memosens technology.) Indicates whether the calibration data could be saved in the sensor. Calibrate the sensor again if the process of saving the data failed.
Note	Electrode in medium?	Ensure that the electrode is in the medium again so measuring can take place.

7.8.2 Calibration redox

Data entry absolute

The transmitter has a calibrated mV display range. One absolute mV value is set with a single buffer solution (adaptation of the measuring chain offset). A buffer solution preferably with 225 or 475 mV is used.



Press  to start calibration.

Function	Options	Info
Note	Calibration with enter data abs.	The type of local calibration selected in the calibration settings is displayed.
Offset	-1500 ... +1500 mV Factory setting 0000 mV	Enter the mV value for the electrode offset (electrode offset = deviation of measured value display from the indicated mV value of the buffer solution). Confirm with  . The entered value is effective immediately. The maximum offset is 400 mV.
Note	Offset too high	Error message if the entered offset leaves the maximum range.
Calibration	Options <ul style="list-style-type: none"> ■ Accept ■ Cancel ■ Repeat calibration 	Ending calibration Accept: When you confirm with  , the new calibration data are accepted. Cancel: The data are not accepted. Calibration is not repeated. Repeat calibration: The data are rejected and calibration is repeated.
Sensor communication	Waiting for sensor response ...	(only available for digital sensors with Memosens technology.) The transmitter transmits calibration data to the sensor.
Note	<ul style="list-style-type: none"> ■ Data saved ■ Data NOT saved 	(only available for digital sensors with Memosens technology.) Indicates whether the calibration data could be saved in the sensor. Calibrate the sensor again if the process of saving the data failed.
Note	Electrode in medium?	Ensure that the electrode is in the medium again so measuring can take place.

Absolute calibration

The transmitter has a calibrated mV display range. One absolute mV value is set with a single buffer solution (adaptation of the measuring chain offset). A buffer solution preferably with 225 or 475 mV is used.

Press  to start calibration.

Function	Options	Info
Note	Calibration with calibration abs.	The type of local calibration selected in the calibration settings is displayed.
Handling instructions	Immerse: Electrode in buffer	Immerse the electrode into the buffer. Confirm with  .
buffer mV value	-1500 ... 1500 mV Factory setting 0225 mV	Enter the buffer mV value. Confirm with  .

Function	Options	Info
Stability check	<ul style="list-style-type: none"> ■ Time: 10 s ■ mV 1: 0 	<p>Wait until the measurement is stable: Time no longer counts. mV value no longer flashes. Once these values are stable, confirm with <input type="button" value="E"/>.</p> <p> Note! Specify the criteria for the stability check in the "Set up 1 > Calibration > Cal settings" menu.</p>
Calibration value notice	Invalid calibration value	This message is displayed if an error is present (e.g. wrong buffer used).
Offset notice	Offset: 0005 mV Good	Information on the offset and quality of the calibration is displayed here.
Calibration	Options <ul style="list-style-type: none"> ■ Accept ■ Cancel ■ Repeat calibration 	Ending calibration Accept: When you confirm with <input type="button" value="E"/> , the new calibration data are accepted. Cancel: The data are not accepted. Calibration is not repeated. Repeat calibration: The data are rejected and calibration is repeated.
Sensor communication	Waiting for sensor response ...	(only available for digital sensors with Memosens technology.) The transmitter transmits calibration data to the sensor.
Note	<ul style="list-style-type: none"> ■ Data saved ■ Data NOT saved 	(only available for digital sensors with Memosens technology.) Indicates whether the calibration data could be saved in the sensor. Calibrate the sensor again if the process of saving the data failed.
Note	Electrode in medium?	Ensure that the electrode is in the medium again so measuring can take place.

Relative data input (only for redox relative)

Entry of two % calibration points to each of which one mV value is assigned.
Press to start calibration.

Function	Options	Info
Note	Calibration with enter data rel.	The type of local calibration selected in the calibration settings is displayed.
Calibration points	Activation and subsequent entry <ul style="list-style-type: none"> ■ 0 ... 30% ■ Voltage -1500 ... +1500 mV ■ 70 ... 100% ■ Voltage -1500 ... +1500 mV Factory setting 20 % Voltage: 0600 mV 80 % Voltage: -600 mV	In this field, create two measured value pairs (pair 1 and pair 2). Measured value pair 1 in the range 0...30 %: Assign, for example, the voltage 0600 mV to the percentage value 20 %. Measured value pair 2 in the range 70...100 %: Assign, for example, the voltage -0600 mV to the percentage value 80 %. The settings made are effective immediately after confirming with <input type="button" value="E"/> .
Note	Offset too high	Error message if the entered offset leaves the maximum range.
Calibration	Options <ul style="list-style-type: none"> ■ Accept ■ Cancel ■ Repeat calibration 	Ending calibration Accept: When you confirm with <input type="button" value="E"/> , the new calibration data are accepted. Cancel: The data are not accepted. Calibration is not repeated. Repeat calibration: The data are rejected and calibration is repeated.









Function	Options	Info
Sensor communication	Waiting for sensor response ...	(only available for digital sensors with Memosens technology.) The transmitter transmits calibration data to the sensor.
Note	<ul style="list-style-type: none"> ■ Data saved ■ Data NOT saved 	(only available for digital sensors with Memosens technology.) Indicates whether the calibration data could be saved in the sensor. Calibrate the sensor again if the process of saving the data failed.
Note	Electrode in medium?	Ensure that the electrode is in the medium again so measuring can take place.

Relative calibration (only redox relative)

For calibration, two tanks are filled with a sample of the medium. The contents of the first tank are detoxicated and called calibration solution 1.

The contents of the second tank are left unchanged and are called calibration solution 2.

Press  to start calibration.

Function	Options	Info
Note	Calibration with calibration rel.	The type of local calibration selected in the calibration settings is displayed.
Handling instructions	Immerse: Electrode in buffer	Immerse the electrode in the detoxicated sample. Confirm with  .
% value buffer	0 ... 30% Factory setting 20 %	Enter the relative redox value of the detoxicated sample. Confirm with  .
Stability check	<ul style="list-style-type: none"> ■ Time: 10 s ■ mV 1: 0 	Wait until the measurement is stable: Time no longer counts. mV value no longer flashes. Once these values are stable, confirm with  .
		 Note! Specify the criteria for the stability check in the "Set up 1 > Calibration > Cal settings" menu.
Handling instructions	Immerse: Electrode in buffer	Immerse the electrode in the unaltered sample. Confirm with  .
% value buffer	70 ... 100% Factory setting 80 %	Enter the relative redox value of the unaltered sample. Confirm with  .
Stability check	<ul style="list-style-type: none"> ■ Time: 10 s ■ mV 1: 0 	Wait until the measurement is stable: Time no longer counts. mV value no longer flashes. Once these values are stable, confirm with  .
		 Note! Specify the criteria for the stability check in the "Set up 1 > Calibration > Cal settings" menu.
Calibration value notice	Invalid calibration value	This message is displayed if an error is present (e.g. offset too large).
Offset notice	Offset: 0005 mV Good	Information on the offset and quality of the calibration is displayed here.
Calibration	Options <ul style="list-style-type: none"> ■ Accept ■ Cancel ■ Repeat calibration 	Ending calibration Accept: When you confirm with  , the new calibration data are accepted. Cancel: The data are not accepted. Calibration is not repeated. Repeat calibration: The data are rejected and calibration is repeated.

Function	Options	Info
Sensor communication	Waiting for sensor response ...	(only available for digital sensors with Memosens technology.) The transmitter transmits calibration data to the sensor.
Note	<ul style="list-style-type: none"> ■ Data saved ■ Data NOT saved 	(only available for digital sensors with Memosens technology.) Indicates whether the calibration data could be saved in the sensor. Calibrate the sensor again if the process of saving the data failed.
Note	Electrode in medium?	Ensure that the electrode is in the medium again so measuring can take place.

8 Maintenance

Take all the necessary measures in good time to ensure the operational safety and reliability of the entire measuring system.

Measuring point maintenance comprises:

- Calibration (see "Calibration" section)
- Cleaning the transmitter, assembly and sensor
- Inspecting cables and connections
- Maintenance of the control unit



Warning!

- When performing work on the device, take possible effects on the process control system or the process itself into account.
- If you have to remove the sensor for servicing or calibration work, pay attention to the hazards caused by pressure, temperature and contamination.
- The control unit and process retractable assembly work with compressed air and pressurized water. Disconnect the air and water supply before working on couplings, valves or pressure switches!
- De-energize the device before you open it.
If work has to be performed while the unit is energized, it may only be carried out by an electrician.
- Power can be supplied to switching contacts by separate circuits. Also de-energize these circuits before you work on the terminals.
- Electronic components are sensitive to electrostatic discharge. Personal protective measures such as permanent grounding with a wrist strap are necessary.
- For your own safety, always use genuine spare parts. The function, accuracy and reliability after repair work are guaranteed with genuine parts.



Note!

Please contact your sales center if you have any questions.

8.1 Maintenance of the overall measuring point

8.1.1 Cleaning the transmitter

Clean the front of the housing with usual commercial cleaning agents.

In accordance with DIN 42 115, the front is resistant to the following:

- Isopropyl alcohol
- Diluted acids (max. 3%)
- Diluted bases (max. 5%)
- Ester
- Hydrocarbons
- Ketones
- Household cleaners



Caution!

When cleaning, never use:

- Concentrated mineral acids or bases
- Benzyl alcohol
- Methylene chloride
- High-pressure steam

8.1.2 Cleaning the sensors

Cleaning the sensor constitutes an integral part of the Topcal S system; thus, additional or external sensor cleaning is normally not necessary. However, before monitoring the sensor, advance external cleaning may be necessary.



Caution!

Set the service switch to "Service", to hold the assembly securely in the Service position.

Please clean fouling on the pH glass electrodes as follows:

- Oily and greasy deposits:
Clean with hot water or tempered detergent (grease remover, e.g. alcohol, acetone, washing up liquid where applicable).



Warning!

When using the following cleaning agents, make sure to protect your hands, eyes and clothing!

- Deposits of lime and metal hydroxide:
Remove deposits with diluted hydrochloric acid (3 %) and then rinse carefully with large amounts of clear water.
- Deposits containing sulfide (from flue gas desulfurizing or sewage treatment plants):
Use a mixture of hydrochloric acid (3 %) and thiocarbamide (usual commercial) and then rinse carefully with large amounts of clear water.
- Deposits containing protein (e.g. food industry):
Use a mixture of hydrochloric acid (0.5 %) and pepsin (usual commercial) and then rinse carefully with large amounts of clear water.
- Fibers, suspended substances:
Water under pressure, poss. with surface-active agents
- Light biological deposits:
Water under pressure

Redox electrodes

Carefully clean the metal pins and surfaces mechanically.



Note!

After mechanical cleaning, the redox sensor can require several hours conditioning time. For this reason, check calibration after one day.

ISFET sensors

- When cleaning ISFET sensors, do not use any acetone as this can damage the material.
- After cleaning with compressed air, ISFET sensors need approx. 5 ... 8 minutes until the closed-control loop is reestablished and the measured value is adjusted to the real value.

In certain circumstances, you can clean blocked diaphragms mechanically (does not apply to ISFET sensors, teflon diaphragms and open ring junction electrodes):

- Use a small key file.
- Only file in one direction.

Air bubbles in the electrode:

- Air bubbles can indicate incorrect mounting. For this reason, check the orientation.
- The range from 15° to 165° to the horizontal is allowed (with the exception of ISFET sensors).
- Horizontal installation or installation with the plug-in head pointing downwards is not permitted.

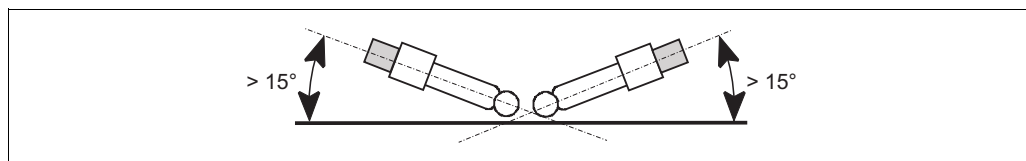

Fig. 59: Permitted angle of installation for glass electrodes

Reducing the reference system

The inner metal lead of the reference system (Ag/AgCl) of a combination electrode or a separate reference electrode is usually light-brown and matt. A silver-colored reference system is reduced and therefore defective. The cause is a current flowing through the reference element. Possible causes:

- Incorrect operating mode selected for the measuring device (PM pin connected but unsymmetrical operating mode selected ("no solution ground"). See the function description on "Selecting the type of connection".
- Shunt in measuring cable (e.g. due to humidity) between reference line and grounded screen or PA line.
- Measuring instrument defective (shunt in reference input or entire input amplifier downstream of PE).

8.1.3 Maintenance of digital sensors

Please proceed as follows to maintain digital sensors with Memosens functionality:

1. If an error occurs or the sensor has to be replaced as per the maintenance diagram, take a new or precalibrated sensor from the lab.
A sensor is calibrated in the lab under optimum external conditions to ensure a higher quality of measurement.
2. Remove the fouled sensor and install the new one.
3. Calibration is necessary if you use a sensor that has not been precalibrated.
4. The sensor data are automatically taken from the transmitter. No release code is necessary.
5. Measuring continues.
6. Take the used sensor back to the lab. You can prepare the sensor for reuse in the lab without causing measuring point downtime.
 - Clean the sensor. For this purpose, use the cleaning agents specified for the sensor.
 - Inspect the sensor for cracks or other damage.
 - If no damage is present, regenerate the sensor. For this purpose, store the sensor in 3M KCl solution for 24 hours.
 - Recalibrate the sensor for reuse.

8.1.4 Liquid KCl supply

- KCl must be bubble-free. In the unpressurized version, check whether the cotton thread is in the hose.
- In the event of counterpressure: Check whether the pressure in the KCl tank is min. 0.8 bar (12 psi) above the medium pressure.
- The consumption of KCl should be low but noticeable. Approx. 1 ... 10 ml/day is a typical value.
- In the case of sensors with a KCl refill opening on the glass shaft, this opening must be free and unobstructed.

8.1.5 Manual calibration

The calibration of the sensor is an integral part of the Topcal S system. An additional or external calibration of the sensor is thus not necessary.

If you are using analog sensors and want to perform a calibration outside the assembly (e.g. for test purposes), observe the operating mode of the pH input. In the "solution ground" (=symmetrical connection) operating mode, the PM line of CPM153 must be immersed in the calibration solution.



Note!

The assembly must be moved to the Service position with the service switch before manual calibration can be performed.

8.1.6 Assembly

To perform maintenance and troubleshooting work on the assembly, please refer to the assembly Operating Instructions. These Operating Instructions contain information on assembling and disassembling, replacing the sensor and seal, resistance and information on spare parts and accessories.

Weekly inspections (recommended timeframe)

- Check that the upper assembly section is sealed against compressed air and is not mechanically damaged.
- Check that the process connection is airtight and sealed towards the process and is not mechanically damaged.
- Check the compressed air pipes and connections for leaks and mechanical damage.

Annual inspections (recommended timeframe)

- Clean the assembly externally as required. To replace seals, the assembly must be clean, dry and, if necessary, decontaminated.
- In the event of inductive feedback: Check the switching distance and adjust it if necessary.
- Replace the non-wetted seals (recommended: Where necessary, at least 1x year).
- Replace the wetted seals (at least 1x year, no further recommendations possible as depends primarily on the process, material and frequency of use of the assembly).
- After the maintenance tasks, carry out the following end test:
 - Assembly moves to the Measuring and Service position?
 - Service and Measure feedback signals available? (Control via the CPM153 status messages)
 - Process connection and compressed air connections tight?
 - Does the meter display plausible values?

Replacement of the sealing elements is dependent on the type of assembly. Instructions for replacement is contained in the appropriate service kit. The requisite service kit can be found in the Operating Instructions on your assembly or in the "Cleanfit retractable assembly" special documentation (SD096C/07/a2).

8.1.7 Cables, connections and power supply lines

Weekly inspections (recommended timeframe)

Check the tightness of:

- Compressed air hoses and connections
- Pressurized water hoses and connections
- Hoses and connections of buffer and cleaner tanks
- Multihose connections at control unit and assembly

Monthly inspections (recommended timeframe)

- If the assembly is located in a humid/wet environment or outdoors and you are using analog sensors, check the sensor plug-in head for leaks or moisture.
- Check that the sensor cables, particularly the external insulation, are in a sound condition. You must replace sensor cables that have become wet inside! Only drying is not sufficient!
- Check cable connections for leaks.

Half-yearly inspections (recommended timeframe)

- Check whether the inner compartment and the circuit boards in Mycom S are clean, dry and free from corrosion.

If not:

- Clean and dry the inner compartment and circuit boards.
- In the event of corrosion, replace the affected circuit boards where necessary.
- Check that the seals and couplings are leaktight and in a sound condition.
- Tighten the terminals in Mycom S.
- If the assembly is located in a dry environment and you are using analog sensors, check the sensor plug-in head for leaks or moisture.

8.1.8 Control unit

Weekly inspections (recommended timeframe)

- Check the compressed air connections for leaks:
 - Pneumatic valves
 - Pumps
 - Pressure switch
- Check the level of the buffer and cleaning solution. Top up if necessary.
- Check the multihose connections on the control unit and assembly for leaks.
- Check the water filter for fouling and clean it where necessary.
- Check the pumps for leaks.

Annual inspections (recommended timeframe)

- Check whether the inner compartment and the circuit boards of the control unit are clean, dry and free from corrosion.
 - If not:
 - Clean and dry the inner compartment and circuit boards.
 - In the event of corrosion, replace the circuit boards where necessary.
 - Check that the seals, couplings and pumps are leaktight and in a sound condition.
- Tighten the terminals in the control unit.
- Test the level measurement for the buffer and cleaner canister.

9 Accessories

9.1 Sensors

- Orbisint CPS11/CPS11D
pH electrode for process engineering with dirt-repellent PTFE diaphragm;
optionally with Memosens technology (CPS11D)
Order depending on version, see Technical Information (TI028C/07/en)
- Orbisint CPS12/CPS12D
Redox electrode for process engineering with dirt-repellent PTFE diaphragm;
optionally with Memosens technology (CPS12D)
Order depending on version, see Technical Information (TI367C/07/en)
- Ceraliquid CPS41/CPS41D
pH electrode with ceramic diaphragm and KCl liquid electrolyte;
optionally with Memosens technology (CPS41D)
Order depending on version, see Technical Information (TI079C/07/en)
- Ceraliquid CPS42/CPS42D
Redox electrode with ceramic diaphragm and KCl liquid electrolyte;
optionally with Memosens technology (CPS42D)
Order depending on version, see Technical Information (TI079C/07/en)
- Ceragel CPS71/CPS71D
pH electrode with double-chamber reference system and integrated bridge electrolyte;
optionally with Memosens technology (CPS71D)
Order depending on version, see Technical Information (TI245C/07/en)
- Ceragel CPS72/CPS72D
Redox electrode with double-chamber reference system and integrated bridge electrolyte;
optionally with Memosens technology (CPS72D)
Order depending on version, see Technical Information (TI374C/07/en)
- Orbipore CPS91/CPS91D
pH electrode with open aperture diaphragm for media with high contamination potential;
optionally with Memosens technology (CPS91D)
Order depending on version, see Technical Information (TI375C/07/en)
- Tophit CPS471/CPS471D
Sterilizable and autoclavable ISFET sensor for food processing and pharmaceuticals, process
engineering, water treatment and biotechnology;
Order depending on version, see Technical Information (TI283C/07/en)
- Tophit CPS441/CPS441D
Sterilizable ISFET sensor for low-conductivity media with liquid KCl electrolyte;
Order depending on version, see Technical Information (TI352C/07/en)
- Tophit CPS491/CPS491D
ISFET sensor with open aperture diaphragm for media with high contamination potential;
Order depending on version, see Technical Information (TI377C/07/en)

9.2 Connection accessories

CPK1 special measuring cable

- For pH/redox electrodes with GSA plug-in head
- Order acc. to product structure, see Technical Information (TI118C/07/en)

CPK9 special measuring cable

- For pH/redox electrodes with TOP68 plug-in head, for high-temperature and high-pressure
applications, IP 68
- Order acc. to product structure, see Technical Information (TI118C/07/en)

CPK12 special measuring cable

- For ISFET sensors and pH/redox electrodes with TOP68 plug-in head;
- Order acc. to product structure, see Technical Information (TI118C/07/en)

CYK10 Memosens data cable

- For digital sensors with Memosens technology (CPSxxD)
- Order acc. to product structure, see Technical Information (TI376C/07/en)

CYK81 Memosens data cable extension

- Underterminated cable for extending sensor connection cables
- 2 x 2 cores, twisted with shield and PVC-jacket (2 x 2 x 0.5 mm² + shield), yard goods
- Minimum length: 10 m
- Order No. 51502543

CYK71 measuring cable

- Underterminated cable for connecting sensors and extending sensor cables
- Yard goods, order numbers:
 - Non-Ex version, black: 50085333
 - Ex version, blue: 51506616

Junction box VBM

- For cable extension, with 10 terminal blocks
- IP 65 (≅ NEMA 4X)
- Aluminum material
- Order numbers:
 - Cable entry Pg 13.5: 50003987
 - Cable entry NPT ½": 51500177

Junction box VBA

- For cable extension, with 10 high-impedance terminal blocks, cable glands
- Polycarbonate material
- Order No. 50005276

Junction box RM

- For cable extension, Memosens or CUS31/CUS41
- With 2 x Pg 13.5
- IP 65 (≅ NEMA 4X)
- Order No. 51500832

9.3 Mounting accessories

- Flat seal for front-panel airtight panel mounting of Mycom S;
Order No.: 50064975
- Weather protection cover CYY101 for mounting on the field device, essential for operating outdoors
Material: Stainless steel 1.4031;
Order No. CYY101-A

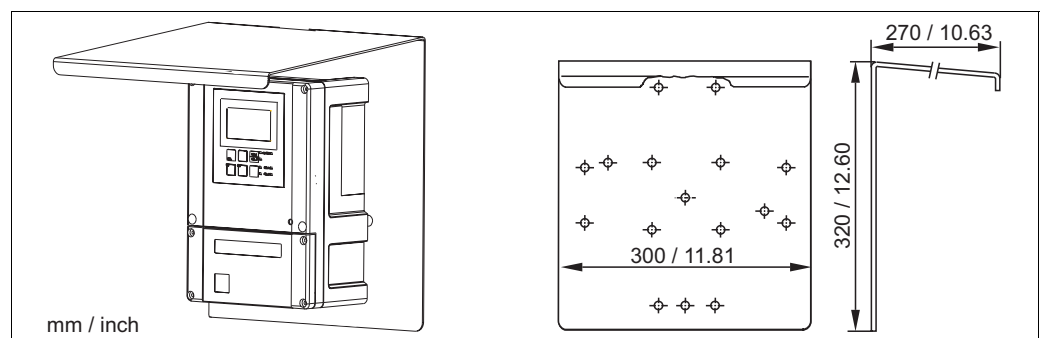

Fig. 60: Weather protection cover for field devices

- Universal post CYY102
Square pipe for mounting transmitters, material: Stainless steel 1.4301 (AISI 304);
Order No. CYY102-A

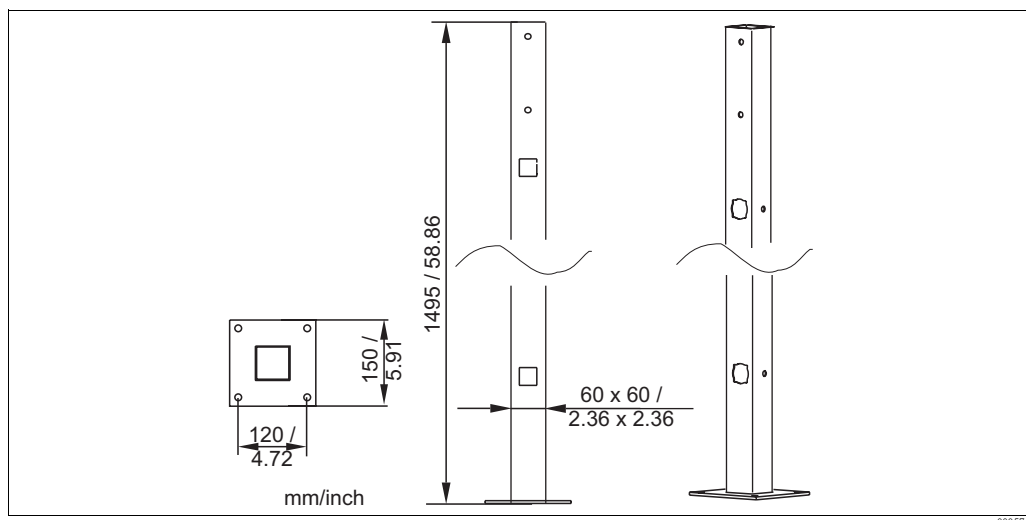

Fig. 61: Universal post CYY102

9.4 Assemblies

- Cleanfit P CPA471
Compact stainless steel retractable assembly for installing in tanks and pipes, for manual or pneumatic remote-control operation
Order acc. to product structure, see Technical Information (TI217C/07/en)
- Cleanfit P CPA472
Compact plastic retractable assembly for installing in tanks and pipes, for manual or pneumatic remote-control operation
Order acc. to product structure, see Technical Information (TI223C/07/en)
- Cleanfit P CPA472D
Retractable assembly for pH/redox measurement in tanks and pipes, manual or pneumatic operation, heavy-duty version made of heavy-duty materials
Order acc. to product structure, see Technical Information (TI403C/07/en)
- Cleanfit P CPA473
Stainless steel process retractable assembly with ball valve shut-off for securely separating the medium from the environment
Order acc. to product structure, see Technical Information (TI344C/07/en)
- Cleanfit P CPA474
Plastic process retractable assembly with ball valve shut-off for securely separating the medium from the environment
Order acc. to product structure, see Technical Information (TI345C/07/en)
- Cleanfit H CPA475
Retractable assembly for pH/redox measurement in tanks and pipes under sterile measuring conditions
Order acc. to product structure, see Technical Information (TI240C/07/en)

9.5 Offline configuration

■ Parawin

Graphic PC program for offline configuration of the measuring point at the PC. You can switch the language via software. Operating system required: Windows NT/95/98/2000.

Offline configuration consists of:

- One DAT module
- DAT interface (RS 232)
- Software

Order No.: 51507563

Option available as of September 2006

- Additional memory module for saving or copying configuration, data logs and logbooks;
Order No.: 51507175

9.6 Housing CYC310

Housing for Topcal S CPC310, with removable rack for buffer and cleaner. Operating panel with alarm LED and locking to start the programs and move the assembly. For Ex and non-Ex applications.

Material: Plastic or stainless steel.

- Plastic version: Viewing window for Mycom S and Memograph S
- Stainless steel version without Memograph: Viewing window for Mycom S
- Stainless steel version with Memograph: Viewing window for Memograph S

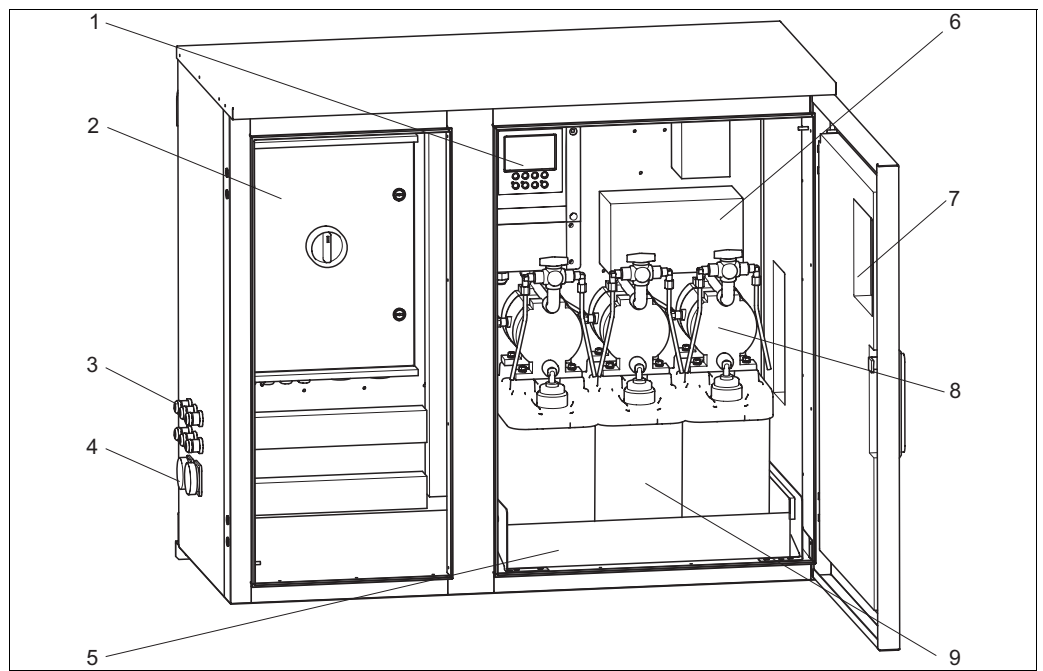

Fig. 62: Interior view of housing CYC310, stainless steel version

- | | | | |
|---|----------------------|---|---|
| 1 | Mycom S CPM153 | 6 | Junction box |
| 2 | Control unit | 7 | Viewing window for display |
| 3 | Cable glands | 8 | Membrane pumps for conveying buffer and cleaner |
| 4 | Multihose connectors | 9 | Buffer and cleaning solutions |
| 5 | Rack | | |

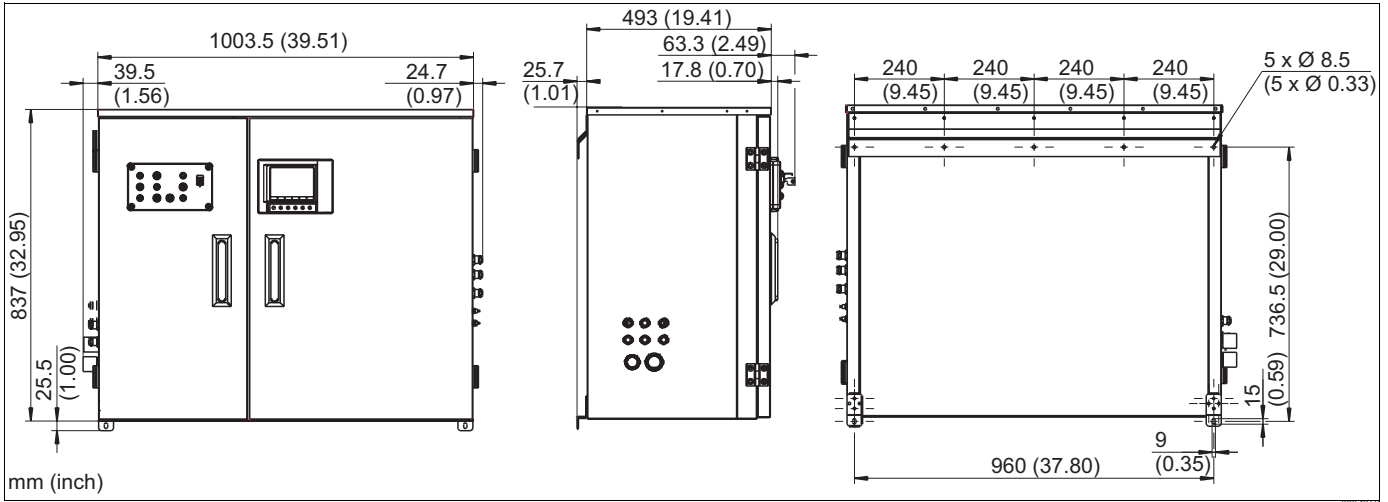

Fig. 63: Dimensions of housing CYC310, stainless steel version

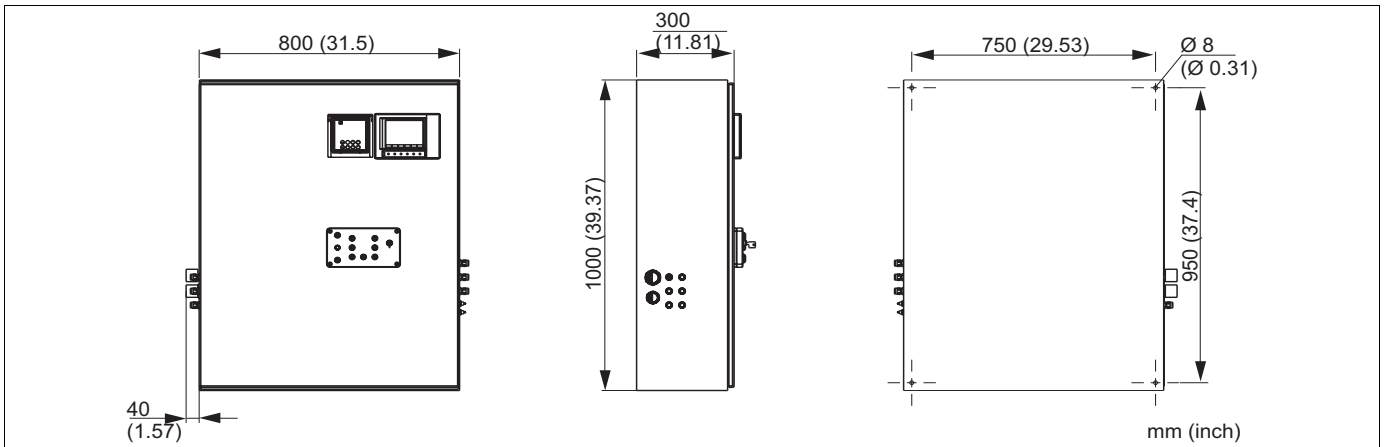

Fig. 64: Dimensions of housing CYC310, plastic version

9.6.1 Product structure

Certificates	
A	Basic features: Non-Ex
G	With ATEX approval, ATEX II (1) 2G EEx, em ib[ia] IIC T4
O	With FM approval Cl. I, Div. 2, with NI input and output circuits, sensor IS Cl. I, Div. 1
P	With FM approval Cl. I, Div. 2, with NI input and output circuits
S	With CSA approval, Cl. I, Div. 2, sensor IS Cl. 1, Div. 1
Power supply	
1	... 230 V AC
2	110 ... 115 V AC
3	24 V AC / DC
Material	
A	Plastic
B	Stainless steel 1.4301 (AISI 304)
Heating	
1	Without electric heating
2	With electric heating
Measured value recording	
A	Without Memograph
B	With Memograph
Assignment	
1	Empty housing, CPC310 not mounted
2	Order position of the associated CPC310
Options	
1	Basic version
CYC310-	Complete order code

9.7 Operating panel for CPC310

Operating panel with alarm LED and key switch to start the programs and move the assembly.
 Order No.: 51512891

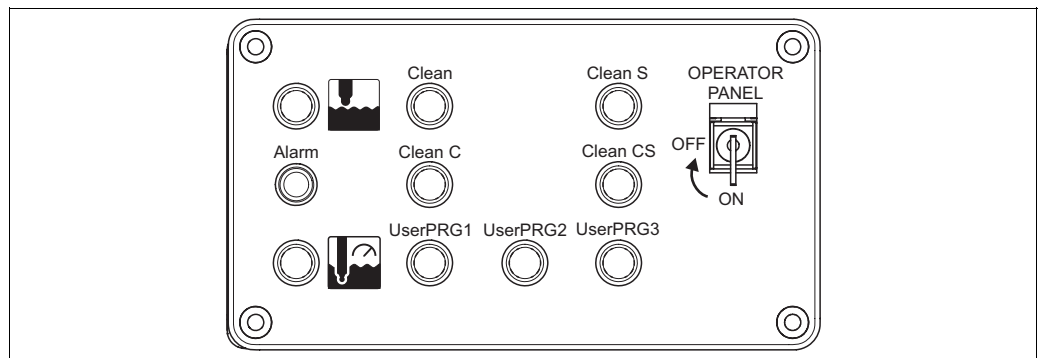

Fig. 65: Operating panel

a0006249

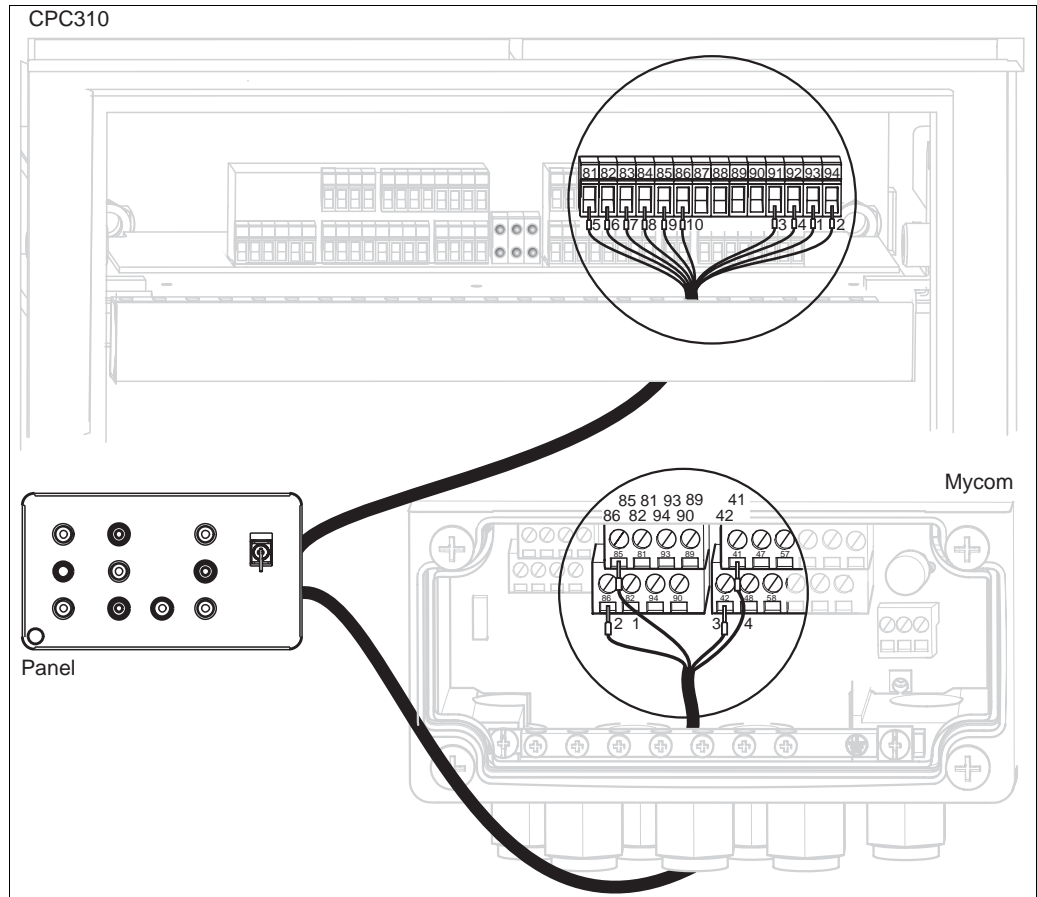

Fig. 66: Operating panel wiring

1. Connect the four-core cable supplied to Mycom S as follows:

Cable core	Mycom connection
1	Terminal 85
2	Terminal 86
3	Terminal 42
4	Terminal 41

2. Connect the twelve-core cable supplied to the control unit as follows:

Cable core	Control unit connection
1	Terminal 93
2	Terminal 94
3	Terminal 91
4	Terminal 92
5	Terminal 81
6	Terminal 82

Cable core	Control unit connection
7	Terminal 83
8	Terminal 84
9	Terminal 85
10	Terminal 86
11 + 12	Do not connect; place cable cores in the cable channel

10 Troubleshooting

10.1 Troubleshooting instructions

The transmitter continuously monitors its functions itself. If an error occurs that is recognized by the device, this is shown on the display. The error number is under the unit displayed for the main measured value. If several errors occur, you can call them up with the MINUS key.

Use the following tables to locate and eliminate an error:

- System error messages: This table indicates the possible error numbers and remedial measures.
- Process-specific errors: In the event of an operating error without a corresponding error message from the transmitter, this table indicates possible process-specific errors, remedial measures and spare parts that may be needed.
- Device-specific errors: In the event of an operating error without a corresponding error message from the transmitter, this table indicates possible device-specific errors, remedial measures and spare parts that may be needed.

Please note the following safety instructions before starting repair work:



Warning!

- De-energize the device before you open it. Check that voltage is not supplied and secure the switch(es) against being switched on unintentionally.
- If work is required under voltage, this may only be carried out by an electrician, but a second person must be present for safety reasons.
- Power can be supplied to switching contacts by separate circuits. Also de-energize these circuits before you work on the terminals.



Caution!

- Electronic components are sensitive to electrostatic discharge. Protective measures such as discharging the operator at PE or permanently grounding the operator with a wrist strap are required.
Particularly dangerous: Synthetic floors at low humidity and synthetic clothing.
- For your own safety, always use genuine spare parts. The function, accuracy and reliability after repair work are only guaranteed with genuine parts.

10.2 System error messages

In the following error list, you can find a description of all the error numbers occurring. Besides the error number, you also have information as to whether this error triggers

- an alarm
- an error current or
- cleaning in the factory setting (= Facy).

To call up the error list, select  > error list.



Note!

- The errors are processed in the alarm menu.
- The second column indicates whether the error is indicated as a failure, maintenance required or function check in accordance with NAMUR document NA64.

Error no.	NAMUR class	Error message	Possible causes/measures	Fault-signaling contact		Error current		Autom. start of cleaning	
				Fact.	User	Fact.	User	Fact.	User
E001	Failure	Memory error	Switch device off and on again. Where necessary, perform "Set default" under "Diagnosis > Service".	yes		no		—	—
E002	Failure	Data error in EEPROM	Repair in the factory where necessary.	yes		no		—	—
E003	Failure	Invalid configuration	Repeat download.	yes		no		—	

Error no.	NAMUR class	Error message	Possible causes/measures	Fault-signaling contact		Error current		Autom. start of cleaning	
				Fact.	User	Fact.	User	Fact.	User
E004	Failure	Incompatible hardware ID	Module does not match device configuration (e.g. non-Ex module in a device approved for use in explosion hazardous areas).	yes		no		—	
E005	Failure	Unknown CPC ID	Control unit is not recognized. Control unit is not compatible with Mycom S software.	yes		no		—	—
E007	Failure	Error transmitter	Test with a new transmitter	yes		no		—	—
E008	Failure	Glass breakage electrode	Impedance of pH glass membrane too low: Check pH sensor, renew if necessary. With ISFET sensor: Leak current > 400 nA. Replace sensor	yes		no		no	
E010	Failure	Error temp. sensor	Check temperature sensor, sensor type and wiring; where necessary; check transmitter with temperature simulator where necessary. ISFET: Check the correct temperature sensor has been selected.	yes		no		no	
E012	Failure	Communication error CPC	Check Topcal S connecting cable.	yes		no		no	
E013	Failure	Assembly has not reached service position	Check assembly position and feedback signals, compressed air present?	yes		no		no	
E014	Failure	Assembly has not reached measuring position	Check the pneumatic hoses to the assembly, assembly mechanically blocked? External power supply 24 V /220 V (not Mycom power supply) available? Fine-wire fuse may be burned through.	yes		no		no	
E017	Failure	Data error in CPC EEPROM	Switch device off and on again. Where necessary, perform "Set default" under "Diagnosis > Service". Repair in the factory where necessary.	yes		no		—	—
E024	Failure	CPC program aborted	Control input 87 / 88 connected: Check ext. control criteria	yes		no		no	
E027	Failure	Error air supply	Pressure below permitted minimum Connected incorrectly, test: Term. D3/D4, Pressure > 2 bar, contact closed: 0 V; Pressure > 2 bar, contact open: 3.2 V;	yes		no		no	
E029	Failure	Sensor self-test failure	Digital sensor discovered an error during self-test. Check sensor, replace where necessary.	yes		no		—	
E030	Failure	SCS message, reference electrode	Reference impedance too high: Check reference element, replace reference or combination electrode where necessary. With ISFET sensor: Leak current > 400 nA	yes		no		—	—
E032	Failure	Slope error electrode	Sensor aged or defective; Reference aged, defective or diaphragm blocked;	yes		no		—	—
E033	Failure	Zero point error electrode	Buffer solutions too old or contaminated; PML not guided into the buffer solutions.	yes		no		—	—
E034	Failure	Offset error electrode		yes		no		—	—
E040	Maintenance	SCC / condition of electrode bad	Check sensor, replace if necessary; clean where required (Glass membrane assigned or run dry; diaphragm blocked)	yes		no		—	
E043	Maintenance	Distance of buffers input 1 too small	Incorrect buffer used; buffer specification incorrect; buffer self-recognition faulty	yes		no		—	
E044	Maintenance	Input 1 not stable	PML missing; sensor too old; sensor partially dry; cable or connector defective	yes		no		—	
E045	Failure	Calibration aborted	Repeat calibration and renew buffer solution; replace electrode where necessary.	yes		no		—	

Error no.	NAMUR class	Error message	Possible causes/measures	Fault-signaling contact		Error current		Autom. start of cleaning	
				Fact.	User	Fact.	User	Fact.	User
E050	Maintenance	Cleaner almost empty	If empty: Top up; If not empty: Check level sensors.	yes		no		no	
E051	Maintenance	Buffer 1 almost empty		yes		no		no	
E052	Maintenance	Buffer 2 almost empty		yes		no		no	
E053	Failure	Actuator failure		yes		no		—	—
E054	Maintenance	Dose-time alarm	Dosing time at full dosing capacity overshoot. Dosing supply interrupted, dosing agent empty or fluctuations in process too high.	yes		no		—	—
E055	Failure	Display range of main parameter undershot	Measuring line disconnected; Sensor in air or air cushion in assembly; Potential matching missing with symmetrical measurement; Static charge in media with lowest conductivity.	yes		no		no	
E057	Failure	Display range of main parameter exceeded		yes		no		no	
E059	Failure	Under range temperature	Temperature sensor defective; Sensor line disconnected or short-circuited; Wrong sensor type selected.	yes		no		no	
E061	Failure	Over range temperature		yes		no		no	
E063	Maintenance	0/4 mA limit output 1	Measured value outside specified current range: Check measured value for plausibility; Where necessary, adjust current output assignment for 0/4 mA and/or 20 mA	yes		no		no	
E064	Maintenance	20 mA limit output 1		yes		no		no	
E065	Maintenance	0/4 mA limit output 2		yes		no		no	
E066	Maintenance	20 mA limit output 2		yes		no		no	
E067	Maintenance	Set point exceeded for controller/limit switch 1	Dosing organ defective; Chemical supply empty; Measured value incorrect -> check plausibility and function; Incorrect control direction set; Incorrect contact assigned; Incorrect control function assigned.	yes		no		no	
E068	Maintenance	Set point exceeded for controller/limit switch 2		yes		no		no	
E069	Maintenance	Set point exceeded for controller/limit switch 3		yes		no		no	
E070	Maintenance	Set point exceeded for controller/limit switch 4		yes		no		no	
E071	Maintenance	Set point exceeded for controller/limit switch 5		yes		no		no	
E073	Failure	Temperature 1, table value undershot	Check plausibility of temperature value; adjust or expand table where necessary.	yes		no		no	
E074	Failure	Temperature 2, table value undershot		yes		no		no	
E075	Failure	Temperature 1, table value exceeded		yes		no		no	
E076	Failure	Temperature 2, table value exceeded		yes		no		no	
E080	Maintenance	Current output 1 range too small	Increase measuring range span for current output assignment.	yes		no		no	
E081	Maintenance	Current output 2 range too small		yes		no		no	
E090	Function check	CPG service switch active	On the CPG, check whether service is actually carried out.	yes		no		no	
E095	Failure	Incompatible hardware (digital sensor)	Digital sensor does not suit transmitter; It may be that the Ex-version of the sensor is combined with the non-Ex version of the transmitter or vice versa.	yes		no		no	

Error no.	NAMUR class	Error message	Possible causes/measures	Fault-signaling contact		Error current		Autom. start of cleaning	
				Fact.	User	Fact.	User	Fact.	User
E100	Function check	Current output simulation on	Check whether functions are intentionally selected.	yes		no		no	
E101	Function check	Service function on		yes		no		no	
E106	Function check	Download active	Wait for download to finish.	yes		no		no	
E116	Failure	Download error	Repeat download.	yes		no		no	
E117	Failure	DAT memory module data error	Check with another DAT memory module; when writing to DAT: Repeat writing process.	yes		no		—	—
E127	Failure	Sensor powerfail	Sensor communication exists but sensor has too little power. Check whether the Memosens connection is correctly connected and locked.	yes		no		—	
E152	Maintenance	PCS Alarm	Sensor defective or totally fouled; water flow in bypass interrupted; Air cushion in assembly; measuring line disconnected; Dosing member defective, chemicals empty.	yes		no		no	
E156	Function check	Calibration timer run out	Time for calibration!	yes		no		no	
E164	Failure	Dynamic range of pH convertor 1 exceeded	Check cable and measuring sensor.	yes		no		—	
E166	Failure	Dynamic range of reference convertor 1 exceeded		yes		no		—	
E168	Maintenance	SCS message ISFET sensor	Leak current > 200 nA. Early warning. Work can continue until error E008/E009 occurs.	yes		no		—	
E171	Maintenance	Current input 1 under range	Measure input signal. Permitted: 4 ... 20 mA Check process variables for measuring device. Change range assignment where necessary.	yes		no		—	
E172	Maintenance	Current input 1 over range		yes		no		—	
E173	Maintenance	Current input 2 under range		yes		no		—	
E174	Maintenance	Current input 2 over range		yes		no		—	
E175	Maintenance	SCS glass critical sensor	Inspect digital sensor for glass breakage and hairline cracks; check medium temperature. Measuring can continue until the error occurs.	yes		no		—	
E177	Maintenance	SCS reference critical sensor	Inspect digital sensor for fouling and damage; clean sensor. Measuring can continue until the error occurs.	yes		no		—	

10.3 Process-specific errors

Use the following table to locate and eliminate any errors occurring.

Error	Possible cause	Tests and / or remedial action	Equipment needed, spare parts
Device cannot be operated, display value 9999	Operation is locked via key pad ("CAL" + "DIAG" pressed simultaneously = locked)	Press "MEAS" and "PARAM" simultaneously to unlock.	
Measuring chain zero-point cannot be set	Reference system poisoned	Test with a new sensor	pH/redox sensor
	Diaphragm blocked	Clean or grind diaphragm	HCl 3 %, file (only for ceramic diaphragm, only file in one direction)
	Measuring line broken	Short-circuit pH input at device ⇒ Display pH 7	
	Asymmetrical sensor voltage too great	Clean diaphragm or test with another sensor	HCl 3 %, file (only for ceramic diaphragm, only file in one direction)
	Potential matching (PA/PM) transmitter ↔ Incorrect medium	Unsymm.: No PM or PM at PE Symm.: PM connection mandatory	See "Connecting analog sensors" section
No calibration possible as sensor adjustment time too long	With ISFET sensor: Film of moisture on measuring surface removed by drying or blowing out with compressed air	Ensure film of moisture or buffer dwell time > 6 min.	
No or creeping display change	Sensor fouled	Clean sensor	See "Cleaning pH/redox electrodes" section.
	Sensor old	Replace sensor	New sensor
	Sensor defective (reference lead)	Replace sensor	New sensor
	Problem with diaphragm or missing electrolyte	Check KCl supply (0.8 bar above medium pressure)	KCl (CPY4-x)
Measuring chain slope cannot be adjusted/slope too low	Connection not at high impedance (humidity, dirt)	Test cable, connector and junction boxes	pH simulator, insulation, see "Checking the connecting cables and junction boxes" section
	Instrument input defective	Directly test instrument	pH simulator
	Sensor old	Replace sensor	pH sensor
Measuring chain slope cannot be adjusted/no slope	Hairline crack in glass membrane	Replace sensor	pH sensor
	Connection not at high impedance (humidity, dirt)	Test cable, connector and junction boxes	pH simulator, insulation, see "Checking the connecting cables and junction boxes" section
	Semiconductor layer in measuring cable not removed	Check inner coaxial cable, remove black layer	
Fixed, incorrect measured value	Sensor not immersed or protection cap not removed	Check installation position, remove protection cap	
	Air cushion in assembly	Check assembly and orientation	
	Earth fault at or in the instrument	Perform test measurement in insulated vessel, with buffer solution where necessary	Plastic vessel, buffer solutions; behavior if connection to process established?
	Hairline crack in glass membrane	Replace sensor	pH sensor
	Device has unpermitted operating status (no reaction to key being pressed)	Switch device off and on again.	EMC problem: If the problem persists, check grounding, shielding and conduits or have checked by Endress+Hauser service.
Incorrect temperature reading	Incorrect temperature sensor connection	Check connections using the wiring diagram	Wiring diagram, "Electrical connection" section
	Measuring cable defective	Check cable for disconnection/short-circuit/shunt	Ohmmeter
	Wrong sensor type	Set the type of temperature sensor at the device (Set up 1 > Temperature)	Glass electrode: Pt 100 ISFET: Pt 1000
	Temperature sensor defective	Check sensor	

Error	Possible cause	Tests and / or remedial action	Equipment needed, spare parts
pH value in process incorrect	No / incorrect temperature compensation	ATC: Activate function MTC: Set process temperature	
	Conductivity of medium too low	Select pH sensor with liquid KCl	e.g. Ceraliquid CPS41, Purisys CPF201
	Flow rate too high	Reduce flow or measure in a bypass	
	Potential in medium	Where necessary, ground with or at PM pin (PM/PE connection)	Problem occurs in plastic pipes in particular.
	Device unsymmetrical and PM connected	Remove PML connection to PM terminal; where necessary ground with/at PM pin (PM connection after PE)	
	Sensor fouled or assigned	Clean sensor (see "Cleaning pH/redox sensors" section)	For very contaminated media: Use spray cleaning.
Measured value fluctuations	Interference in measuring cable	Connect cable shield as per wiring diagram.	See "Electrical connection" section.
	Interference on signal output cable	Check cable routing, route cable separately where necessary.	Signal output and measuring input cables
	Interference potential in medium	Measure symmetrically (with PML).	Where necessary, ground medium with PM/PE.
	No potential matching (PA/PM) with symmetrical input	Connect PM pin in assembly with device PA/PM.	
Controller / limit contact not working	Controller switched off	Activate controller.	See "Set up 1 > Relays" section.
	Controller in "Manual / Off" mode	Select "Automatic" or "Manual on" operating mode.	Key pad,  > Manual operation > Relays
	Pickup delay setting too long	Switch off or shorten pickup delay time.	See "Set up 2 - Limit switch" section.
	"Hold" function active "Auto-hold" with calibration, "Hold" input activated, Manual "Hold" via keypad active, "Hold" active during configuration	Determine and eliminate reason for Hold if not desired	"Hold" is shown on display if active.
Controller / limit contact work continuously	Controller in "Manual / On" mode	Set controller to "Manual / Off" or "Automatic".	Key pad > Manual operation > Relays
	Dropoff delay setting too long	Reduce dropoff delay time.	See "Set up 2 - Limit switch" section.
	Closed-control loop interrupted	Check measured value, current output or relay contacts, adjusters, chemical supply.	
No current output signal	Line open or short-circuited	Disconnect both (!!!) cables and measure directly at the device.	mA meter 0–20 mA DC
	Output defective	Renew controller module.	
	Current outputs encoded as passive and no additional power unit connected	Recode current outputs to active (see "Wiring - Current output" section) or connect power unit.	
	Jumpers for current outputs missing	Attach jumpers as per the desired encoding (see "Wiring - Current outputs" section).	
Fixed current output signal	Current output simulation on	Switch off simulation.	Check under "  > Service > Simulation".
	Processor system inactive	Switch device off and on again.	EMC problem: Check the installation if the problem persists.
	"Hold" is active	Hold status, see display.	
Incorrect current output signal	Incorrect current assignment	Check current assignment: 0–20 mA or 4–20 mA?	See "Set up 1 - Current outputs" section.
	Incorrect signal assignment	Every current output can be assigned to every measured value (pH or temp).	Check under "  > Current output"
	Total load in the current loop too high (> 500 Ω)	Disconnect output and measure directly at the device.	mA meter for 0–20 mA DC
Data cannot be saved	No DAT memory module present		DAT available as accessory, see the "Accessories" chapter.

Error	Possible cause	Tests and / or remedial action	Equipment needed, spare parts
CPG310 control unit not working	No supply voltage	Check connection	
	Fuse defective	Check fuse and replace where necessary	
	Switch to "Service"	Turn switch to "Measure"	
No buffer and cleaner pumped	Tank empty	Check error messages Test functions in manual mode	Control LEDs CPG310: V1: Additional valve 1 active V2: Additional valve 2 active MEAS: Assembly in measuring operation Alive: LED flashes irregularly if function OK
	Line blocked		Feedback pressure switch (see item number 440 in "Spare parts" section), "normally closed contact" type ("NC");
	Suction length longer than 2 m	Reduce suction length to maximum 2 m	Without pressure = closed With pressure = open
	Pump defective	Check error messages	
	Multihose defective	Test functions in manual mode	
Compressed air or rinse water are not pumped	Pressure reduced in the pipe	Check pipe	
	Line blocked		
Assembly remains in the "Service" position	No compressed air	Check error messages Test functions in manual mode	Control LEDs CPG: V1: Additional valve 1 active V2: Additional valve 2 active MEAS: Assembly in measuring operation Alive: LED flashes irregularly if function OK
	Switch to "Service"	Disconnect pressure switch and check with ohmmeter	
	Confirmation of position incorrect		
Assembly remains in the "Measure" position	No compressed air		Feedback pressure switch (see item number 440 in "Spare parts" section), "normally closed contact" type ("NC");
	Switch to "Measure"		Without pressure = closed With pressure = open
	Confirmation of position incorrect		
Assembly constantly moves	Pneumatic hoses to assembly not correctly connected.	Check pneumatic hoses.	
Assembly moves several times without correct feedback	Pneumatic connections mixed up	See "Pneumatics and hydraulics, CPG" section. <ul style="list-style-type: none"> ■ Hose 2 "Measure" at valve 5 at front ■ Hose 3 "Service" at valve 5 at rear 	
	Feedback not correctly connected	See "Pneumatics and hydraulics, CPG" section. <ul style="list-style-type: none"> ■ Hose 5 "Measure feedback" (term. 11/12) ■ Hose 6 "Service" feedback (term. 13/14) 	
	Feedback switch misaligned	Feedback switch under pressure <ul style="list-style-type: none"> ■ Open: Term. 11/12-13/14 = 14 V ■ Closed: Term. 11/12-13/14 = 0 V 	
	Assembly was moved manually. Feedback signal is thus undefined.	Position change via manual operation menu	



10.4 Device-specific errors

The following table supports you during diagnosis and provides information on the necessary spare parts, where applicable.

Depending on the degree of difficulty and measuring media available, diagnosis is carried out by:

- Specialized staff of the owner-operator
- Electrical technicians of the owner-operator
- System creator/operator
- Endress+Hauser Service

Information on the exact names for spare parts and the installation of these parts is found in the "Spare parts" section.

Error	Possible cause	Tests and / or remedial action	Executed, equipment needed, spare parts
Display dark, no light emitting diode active	No line voltage	Check whether line voltage present.	Electrician / e.g. multimeter
	Incorrect supply voltage or too low	Compare actual line voltage and information on the nameplate.	User (Energy supply company or multimeter data)
	Connection defective	Terminal not tightened; Insulation jammed; Incorrect terminals used.	Electrical technician
	Device fuse defective	Compare line voltage and information on the nameplate and replace fuse.	Electrician/suitable fuse; See "Spare parts" section.
	Power unit defective	Replace power unit. Pay attention to version.	Local diagnosis: All 6 LEDs on the M3G module must light up.
	Central module defective (if all 6 LEDs in the M3G power unit light up)	Replace central module. Pay attention to version.	Diagnosis by Endress+Hauser Service on site, test module required
	Ribbon cable loose or defective	Check ribbon cable, replace if necessary.	Cable on the side of the M3G module welded in.
Display dark, light emitting diode active	Central module defective (module: M3Cx-x)	Replace central module M3Cx-x. Pay attention to version.	Diagnosis by Endress+Hauser Service on site, test module required
Display shows value but – no change in display and/or – Device cannot be operated	Instrument or module in instrument not correctly installed	Check module connections	Perform with the aid of the device view in the "Spare parts" section.
	Operating system in impermissible state	Switch device off and on again.	Possible EMC problem: If the problem persists, check installation or have checked by Endress+Hauser service.
Device gets hot	Voltage incorrect/too high	Compare line voltage and information on the nameplate.	User, electrical technician
	Power unit defective	Replace the power unit.	All 6 red LEDs on the M3G module must light up.
Incorrect measured pH / mV value and / or measured temperature value	Transmitter module defective (module: MKxx). Please first perform tests and take measures as outlined in the "Process errors without messages" section	Test measuring inputs: – Connect pH, Ref and PM directly at the device with jumpers = display pH 7 – 100 Ω resistance at terminals 11 / 12 + 13 = Display 0 °C	If test negative: Replace module (observe version). Perform with the aid of the device view in the "Spare parts" section.  Caution! Display approx. pH 7, value depends on the zero point error in the last calibration.
Current output, incorrect current value	Calibration incorrect	Check with integrated current simulation, connect mA meter directly to the current output.	If simulation value incorrect: Calibration in the factory or new M3Cx-x module required. If simulation value correct: Check current loop for load and shunts.
	Load too high		
	Shunt/short to ground in current loop		
	Incorrect operating mode	Check whether 0–20 mA or 4–20 mA is selected.	
No current output signal	Current output stage defective (M3CH-x module)	Check with integrated current simulation, connect mA meter directly to the current output.	If test negative: Replace central module M3CH-x (pay attention to version).
	Device with PROFIBUS interface	PROFIBUS devices do not have a current output	Info see  > Instrument version".

10.5 Response of outputs to errors

10.5.1 Current output behavior

An error current is output at the current outputs if an error occurs in the system. You can set the value of this error current in the Alarm menu (see "Set up 1 - Alarm" section). If you have configured controllers to function via a current output no error current is output at this current output in the event of an error.

10.5.2 Response of contacts to errors

For every error message, you can individually set whether the error triggers an alarm (see "System error messages" section, processing errors in the "Set up 1 - Alarm" section). Failure messages always generate an alarm (as per NAMUR).

Behavior with standard setting

Device status	Alarm relay	Limit value / Controller
Normal operation	Picked up (failsafe behavior)	Appropriate configuration and operating status
Alarm	Dropped out	
Voltage-free	Dropped out	Dropped out

Behavior with NAMUR setting (contacts configured as normally closed contacts)

Device status	Alarm relay	Maintenance relay	Function check	Limit value / Controller
Normal operation	Picked up (failsafe behavior)	Picked up	Picked up	Appropriate configuration and operating status
Failure	Dropped out	Picked up	Picked up	Appropriate configuration and operating status
Maintenance required	Picked up	Dropped out	Picked up	Appropriate configuration and operating status
Function check	Picked up	Picked up	Dropped out	Appropriate configuration and operating status
Voltage-free	Dropped out	Dropped out	Dropped out	Dropped out

10.5.3 Response of contacts to power failure

The contacts can be defined as normally open or normally closed contacts in the "Set up 1 > Relays" menu (see "Set up 1 - Relays" section). In the case of a power failure, the contacts will act according to the setting you make.

10.5.4 Assembly behavior

Problem	CPM153 behavior	CPG behavior	Assembly behavior
CPM153 voltage failure during measurement	No function		
CPM153 voltage failure during maintenance	No function		
CPG voltage failure during measurement	Error message E012	All valves closed	Can be pressed from the process
CPG voltage failure during maintenance	Error message E012	All valves closed	Stays in service position
Air failure during measurement	Error message E027		Can be pressed from the process
Air failure during maintenance	Error message E027		Stays in service position
Air failure during automatic cleaning	Error message E027		Stays in service position
Buffer 1 / 2 empty	Error message E051/E052		
Cleaner empty	Error message E050		

10.6 Spare parts

Please order spare parts from your local sales center. For this purpose, use the order numbers listed in the "Spare part kits" section.

You should **always** quote the following information on the spare parts order:

- Device order code
- Serial no.
- Software version if possible

You can refer to the nameplate for the order code and serial number.

The software version is provided in the device software (see "Operation" section) provided the processor system of the device is still working.

10.6.1 Device view Mycom S

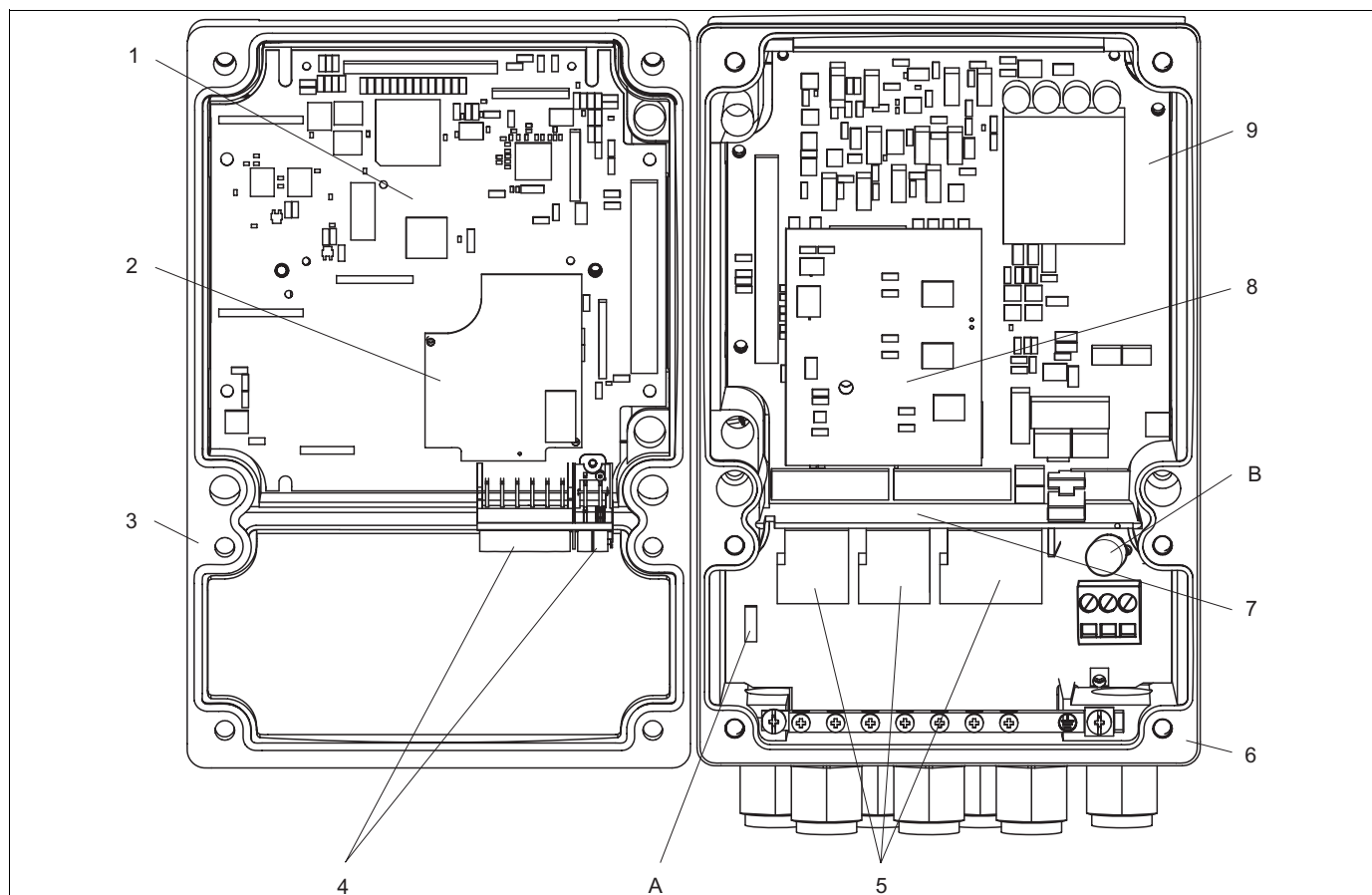

Fig. 67: Interior view

- A Slot for DAT module
- B Fuse

The interior view contains the components and spare parts of the device. You can take the spare parts and the corresponding order number from the following section.

10.6.2 Spare parts list Mycom S

Item No.	Kit name	Contents / Use	Order number
5	Standard + HART connector PCB	Module M3K/non-Ex	51507084
9	Power supply 24 VAC/DC non-Ex	Module M3G, power unit + 3 relay	51507089
1	Controller module pH, 2 x current output	Module M3CH-S2/non-Ex	51517384
2	pH input module, glass + ISFET	Module MKP2/Ex and non-Ex	51507096
2	pH input module, Memosens	Module MKD1/Ex and non-Ex	51514966
8	Relay module with 3 additional relays	Module M3R-3/Ex and non-Ex	51507097
4	Terminal set for pH input, glass, 2 pair	Six-pole terminal + two-pole terminal, two pieces each	51507100
4	Terminal set for pH input, ISFET, 2 pair	Six-pole terminal + two-pole terminal, two pieces each	51507858
	Jumper set	5 sets of all three jumper types	51507102
7	Partition plate for connection compartment	5 piece, partition plates	51507103
3	Housing upper section	Upper section with keyboard foil, connection compartment cover, hinge, nameplate/non-Ex	71003923
6	Housing base	For one and two-circuit devices, cpl./non-Ex	51507106

10.6.3 Control unit device view

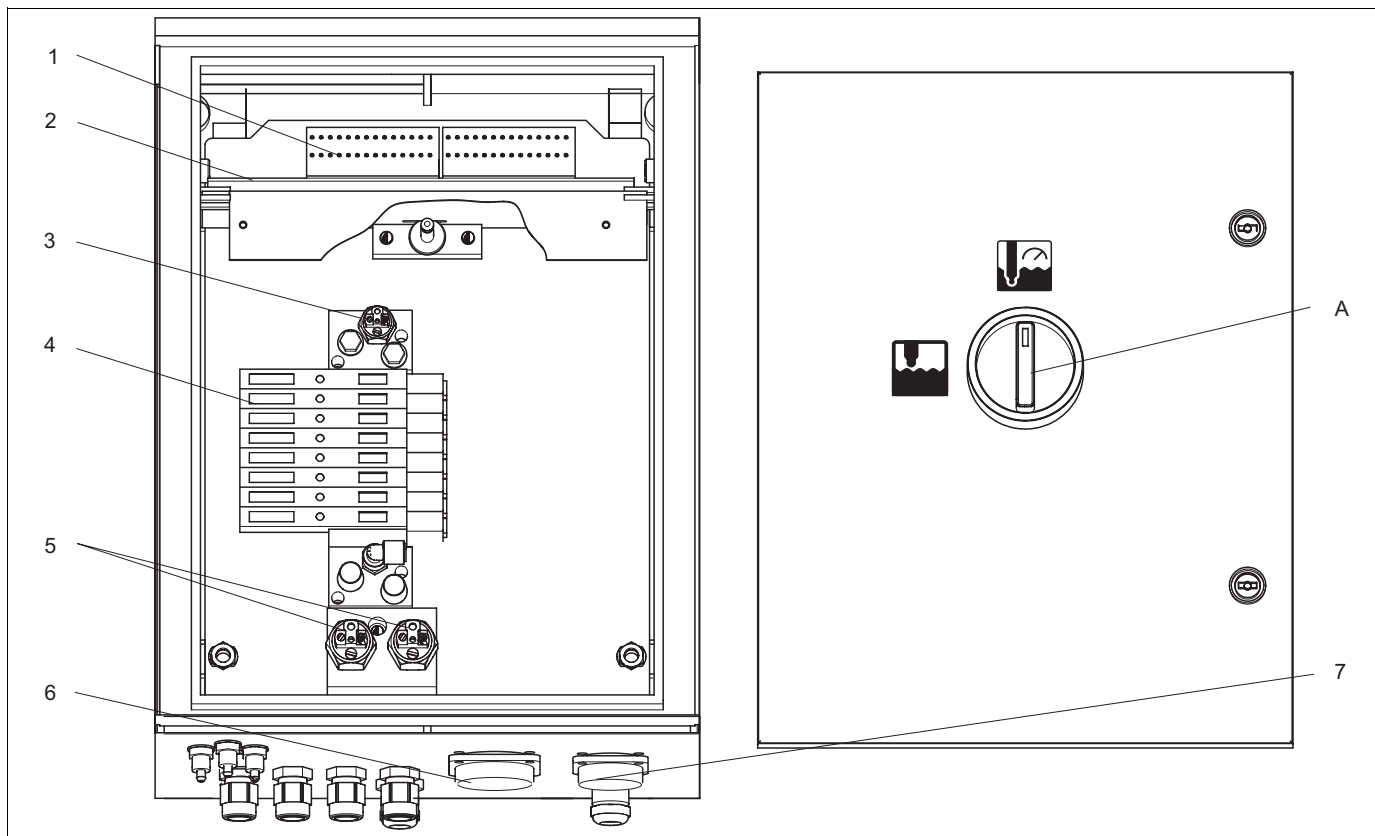

Fig. 68: Interior view

A Service switch

The interior view contains the components and spare parts of the device. You can take the spare parts and the corresponding order number from the following section.

10.6.4 Control unit spare parts list

Item No.	Kit name	Contents / Use	Order number
1	Terminal block set	All requisite terminal blocks/Ex and non-Ex	51507436
2	Electronics module 24 V DC/AC	Tested, complete module/non-Ex	71029974
2	Electronics module 230 V AC	Tested, complete module/non-Ex	71029976
3	Pneumatic pressure control console	Pressure switch/Ex and non-Ex	51507448
4	Pneumatic module, 8 valves	Module complete with 8 solenoid valves / non-Ex	71029973
	Individual valve	Electrically operated valve (coil) / non-Ex	51507449
5	Assembly feedback pressure switch	Pressure switch, NO contact/Ex and non-Ex	51507447
6	Mutihose coupling, air MS 8	Rapid coupling, connector and installation socket 8-pole MS, (assembly compressed air) / Ex and non-Ex	71029977
7	Mutihose coupling, air MS 5	Rapid coupling, connector and installation socket 5-pole MS, (pump compressed air) / Ex and non-Ex	71029987
	Mutihose air assembly, 5 m (16.4 ft)	Mutihose with rapid coupling, MS, 8-fold, compressed air assembly	71029919
	Mutihose air assembly, 10 m (32.8 ft)	Mutihose with rapid coupling, MS, 8-fold, compressed air assembly	71029922

Item No.	Kit name	Contents / Use	Order number
	Multihose air for pumps, 2.5 m (8.2 ft)	Multihose with rapid coupling, MS, 5-fold, compressed air pump drive	71029923
	Internal hose system complete	Hoses, hose connector, glands, small ball valves for pumps, seals and insertion nipples and sockets for rapid coupling/Ex and non-Ex	71029991
	Pressure-reduction valve kit	Pressure reduction valve, filter/Ex and non-Ex	51505755
	Water filter kit	Water filter 100 µm / Ex and non-Ex	71031661

10.6.5 View of canister with membrane pump and level sensor

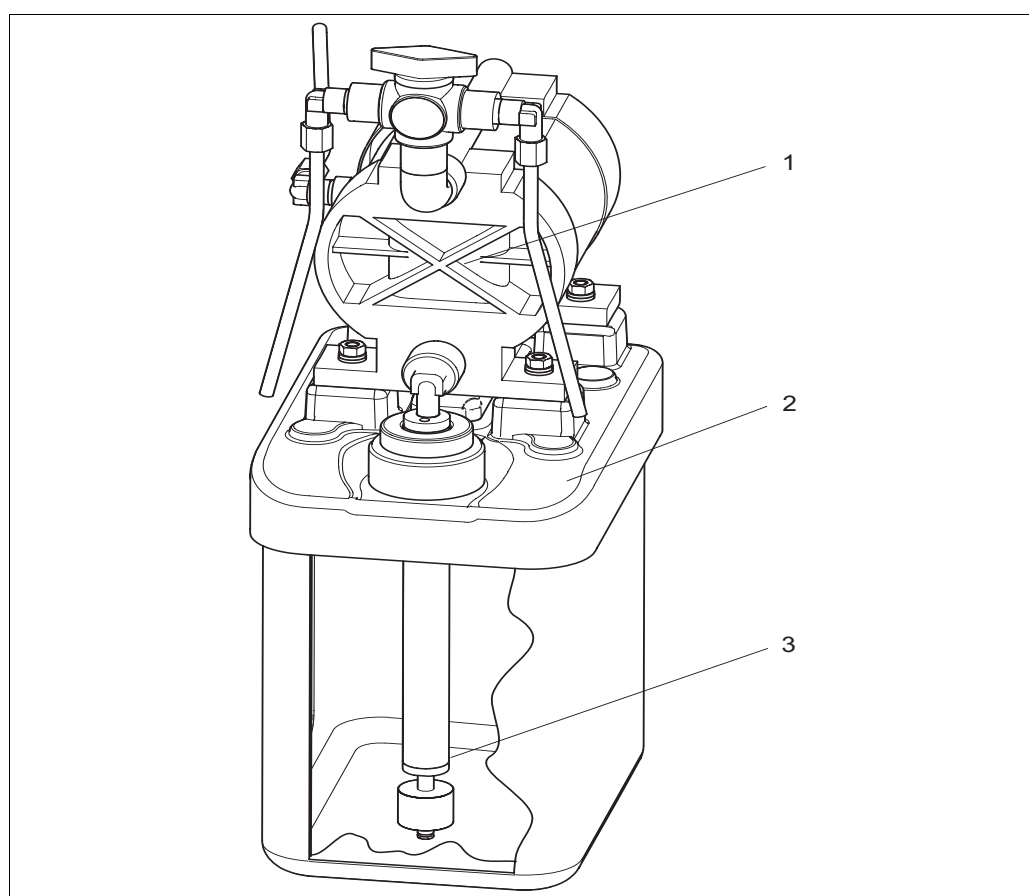

Fig. 69: Buffer and cleaner canister with membrane pump and level sensor

10.6.6 Spare parts list for canister with membrane pump and level sensor

Item No.	Kit name	Contents / Use	Order number
1	Double-membrane pump with PVDF membrane	Double-membrane pump, individual, PVDF membrane (option)	71029963
2	Canister with pump and fittings	Canister module complete with membrane pump, fittings, ball valve, level probe	71029969
3	Level probe with coupling	Level probe, 1 piece, blue, complete with coupling and cable	71029990
	Vent hoses for membrane pumps, 1.5 m (4.92 ft)	Vent hose system with 3 PVC hoses	71029928

10.6.7 Pneumatic and hydraulic control unit

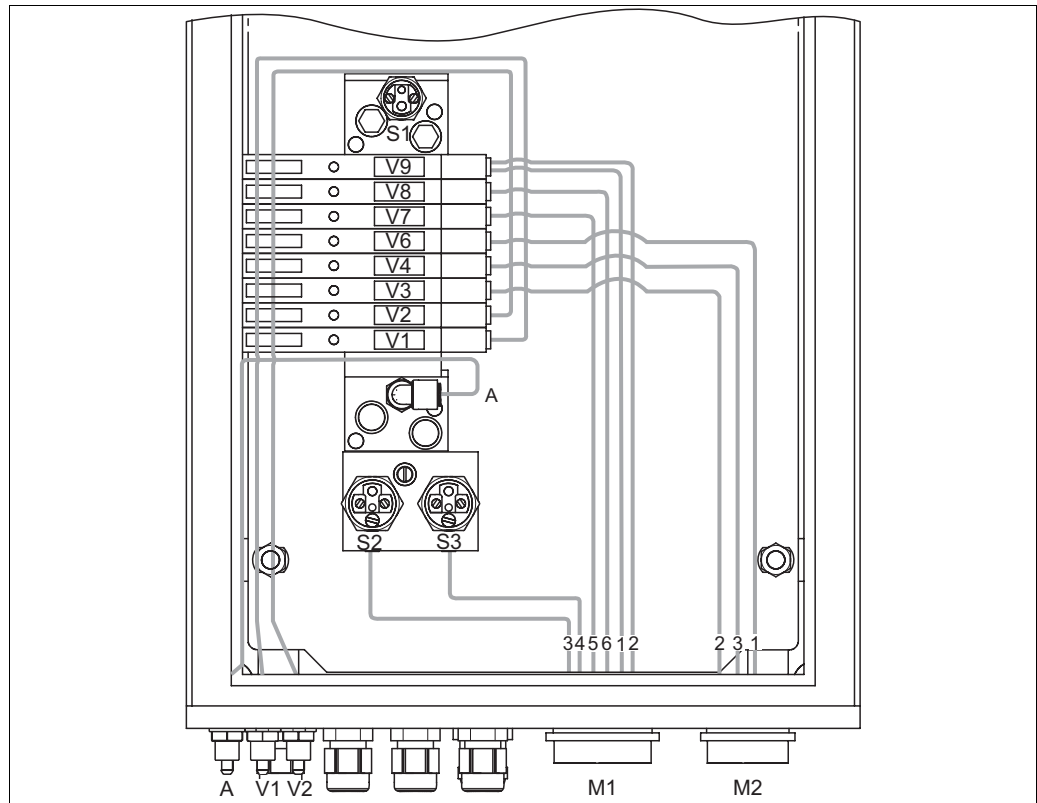

Fig. 70: Pneumatic

A Compressed air supply

V1 Additional valve connection, V1

V2 Additional valve connection, V2

M1 Multihose connector Pg 29

M2 Multihose connector Pg 21

S1-3 Pressure switch

V1-9 Valves

Valves (controlled electrically)	Pressure switch	Multihose connection	Signal/Use	Assembly connection
V9 front		M1-2	"Service" assembly	<ul style="list-style-type: none"> CPA471/472/475: Upper limit position switch - input (=1); lower G¼ coupling CPA473/474: Connection number 3
V9 rear		M1-1	Assembly "Measure"	<ul style="list-style-type: none"> CPA471/472/475: Lower limit position switch - input (=1); upper G¼ coupling CPA473/474: Connection number 2
	S3	M1-4	"Service" feedback (not used for inductive feedback)	<ul style="list-style-type: none"> CPA471/472/475: Upper limit position switch - output (=2) CPA473/474: Connection number 6
	S2	M1-3	"Measure" feedback (not used for inductive feedback)	<ul style="list-style-type: none"> CPA471/472/475: Lower limit position switch - output (=2) CPA473/474: Connection number 5
V8		M1-6	Purging air	
V7		M1-5	Controlling 2/2-way valve of the rinsing block for water	
V6		M2-1	Controlling membrane pump for cleaner	
V4		M2-3	Controlling membrane pump for buffer 2	
V3		M2-2	Controlling membrane pump for buffer 1	
V2		None	Additional valve for sealing water, steam etc.	
V1		None	Additional valve for sealing water, steam etc.	
	S1	None	Compressed air monitoring	

Multihose connections

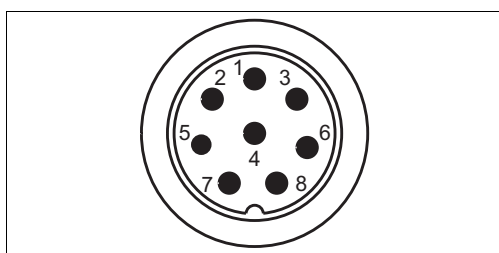

a0006449

Fig. 71: Multihose connector M1 (Pg 29) at housing

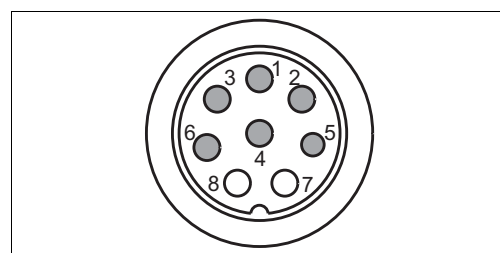

a0006025

Fig. 72: Multihose socket M1 (Pg 29) at hose

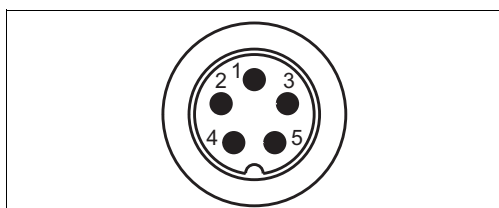

a0006446

Fig. 73: Multihose connector M2 (Pg 21) at housing

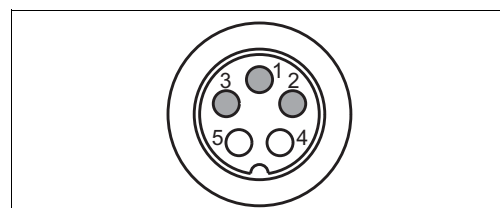

a0006024

Fig. 74: Multihose socket M2 (Pg 21) at hose

10.6.8 Rinsing block

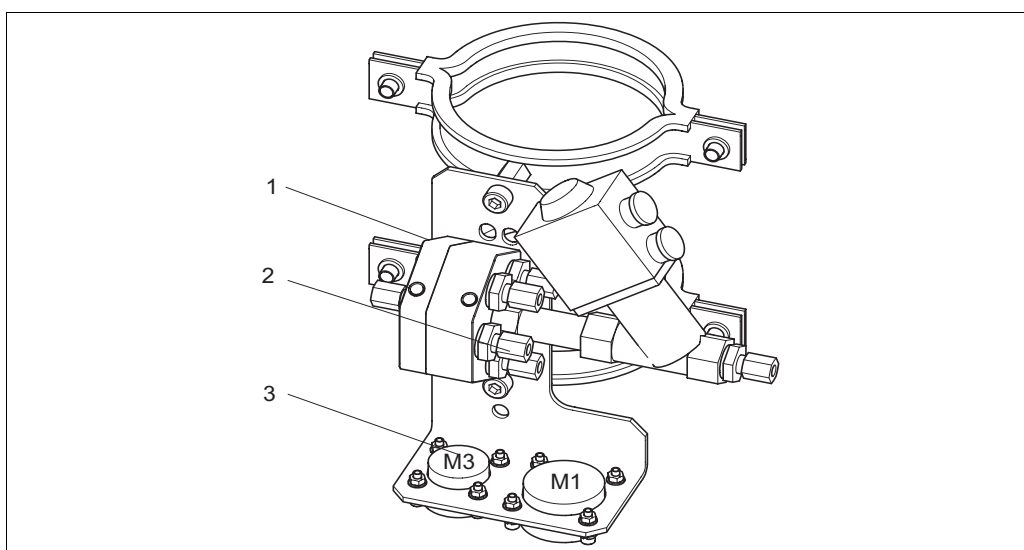

a0006186

Fig. 75: Rinsing block

Ite m No.	Kit name	Contents / Use	Order number
1	PVDF rinsing block, G ¼, Viton	Complete PVDF rinsing block, G ¼, Viton seals	71029930
1	Rinsing block PVDF, G ¼, Kalrez	Complete PVDF rinsing block, G ¼, Kalrez seals	71029931
1	PVDF rinsing block, NPT ¼", Viton	Complete PVDF rinsing block, NPT ¼", Viton seals	71029938
1	PVDF rinsing block, NPT ¼", Kalrez	Complete PVDF rinsing block, NPT ¼", Kalrez seals	71029942
1	VA rinsing block, G ¼, Viton	Complete rinsing block, stainless steel 1.4404 (AISI 316L), G ¼, Viton seals	71029943
1	VA rinsing block, G ¼, Kalrez	Complete rinsing block, stainless steel 1.4404 (AISI 316L), G ¼, Kalrez seals	71029946

Item No.	Kit name	Contents / Use	Order number
1	VA rinsing block, NPT ¼", Viton	Complete rinsing block, stainless steel 1.4404 (AISI 316L), NPT ¼", Viton seals	71029948
1	VA rinsing block, NPT ¼", Kalrez	Complete rinsing block, stainless steel 1.4404 (AISI 316L), NPT ¼", Kalrez seals	71029951
2	Valves, rinsing adapter, PVDF, Viton	Check valves for rinsing adapter, 5-piece, PVDF, Viton seals	71029955
2	Valves, rinsing adapter, PVDF, Kalrez	Check valves for rinsing adapter, 5-piece, PVDF, Kalrez seals	71029956
2	Valves, rinsing adapter, VA, Viton	Check valves for rinsing adapter, 5-piece, stainless steel 1.4404 (AISI 316L), Viton seals	71029958
2	Valves, rinsing adapter, VA, Kalrez	Check valves for rinsing adapter, 5-piece, stainless steel 1.4404 (AISI 316L), Kalrez seals	71029960
3	Assembly multihose coupling, Viton	Rapid coupling, connector and installation socket, 5-pole, HC4, Viton, media to rinsing block	71029988
3	Assembly multihose coupling, Kalrez	Rapid coupling, connector and installation socket, 5-pole, HC4, Kalrez, media to rinsing block	71029989
	Multihose media assembly, 5 m (8.2 ft)	Multihose with rapid coupling, HC4, 5-fold, without heating, Hastelloy coupling / cleaner and buffer to rinsing block	71029924
	Multihose media assembly, 10 m (16.4 ft)	Multihose with rapid coupling, HC4, 5-fold, without heating, Hastelloy coupling / cleaner and buffer to rinsing block	71029925
	Multihose media assembly, 5 m (8.2 ft), heated	Multihose with rapid coupling, HC4, 5-fold, with heating, Hastelloy coupling / cleaner and buffer to rinsing block	71029926
	Multihose media assembly, 10 m (16.4 ft), heated	Multihose with rapid coupling, HC4, 5-fold, with heating, Hastelloy coupling / cleaner and buffer to rinsing block	71029927
Connecting assembly to rinsing block			
	CPA472/474 rinsing nozzle G ¼, PVDF		51512705
	CPA471/473 rinsing nozzle G 1/8 - G ¼, VA		51503771
	CPA472D, HC4, G ¼: Swagelok rinse connection	Rinse connection for pipe or hose 6 mm, internal (only for rinse chamber with G ¼)	71026794
	CPA472D, titanium, G ¼: Swagelok rinse connection	Rinse connection for pipe or hose 6 mm, internal (only for rinse chamber with G ¼)	71026795
	CPA472D, stainless steel 1.4571 (AISI 316Ti), G ¼: Swagelok rinse connection	Rinse connection for pipe or hose 6 mm, internal (only for rinse chamber with G ¼)	71026796

10.7 Replacing the device fuse



Warning!
Risk of injury

- Before replacing the fuse, make sure the device is voltage-free.
- Position of safety switch: "B" in device view.
- Only use a fine-wire fuse 5 x 20 mm (0.2 x 0.79 in) with 3.15 A, medium-blow. All other fuses are not permitted.

10.8 Return

If the device has to be repaired, please return it *cleaned* to your sales center.
For returns please use the original packaging.

10.9 Disposal

The device contains electronic components and must therefore be disposed of in accordance with regulations on the disposal of electronic waste.
Please observe local regulations.

The assembly may be contaminated by the medium. Therefore, when disposing of it, the plant disposal or safety officer must be consulted.

11 Technical data

11.1 Input

Mycom S CPM153		
Binary inputs E1 to E3	Input voltage: Internal resistance:	10 ... 50 V $R_i = 5 \text{ k}\Omega$
Current inputs 1 / 2 (passive optional)	Signal range: Input voltage range:	4 ... 20 mA 6 ... 30 V
CPG310		
Binary inputs	Input voltage: Internal resistance: Minimum switching signal duration:	10 ... 40 V $R_i = 5 \text{ k}\Omega$ 500 ms

11.2 Output

Mycom S CPM153		
Output signal	0/4 ... 20 mA	
Signal on alarm	2.4 or 22 mA in the event of an error	
Load of active current output	Max. 600 Ω (depends on operating voltage)	
Passive current output	Operating voltage range:	6 ... 30 V
Galvanic isolation	The following are on the same potential: <ul style="list-style-type: none"> ■ Current output 1 and auxiliary voltage All other circuits are galvanically isolated from one another.	
Output distribution	pH:	Adjustable, 0 ... 18 pH
	Redox Absolute: Relative:	Adjustable, 300 ... 3000 mV Adjustable, 0 ... 600 %
	Temperature:	Adjustable, 17 ... 200 °C (62.6 ... 392 °F)
Overvoltage protection	As per EN 61000-4-5:1995	
Auxiliary voltage output	Output voltage: Output current:	15 V DC Max. 9 mA
Contact outputs	Switching voltage: Switching current: Switching power: Operating life:	Max. 250 V AC / 125 V DC Max. 3 A Max. 750 VA ≥ 5 million switching cycles
Controller	Function (adjustable):	Pulse-length controller (PWM) Pulse-frequency controller (PFM) Three-point stepping controller (3-point step) Analog (via current output)
	Controller behavior: Control gain K_R : Integral action time T_n : Derivative action time T_v : Max. frequency with pulse-frequency controller: Period length for pulse-length controller: Minimum switch-on period for pulse-length controller:	P / PI / PID 0.01 ... 20.00 0.0 ... 999.9 min 0.0 ... 999.9 min 120 min ⁻¹ 1 ... 999.9 s 0.4 s

CPG310		
Digital outputs	Optoelectronic coupler, max. switching voltage Max. switching current: Max. switching power:	30 V DC 100 mA 3 W

11.3 Power supply

Mycom S CPM153		
Supply voltage	Version CPM153-xxxx 0 xxxx Version CPM153-xxxx 8 xxxx	100 ... 230 V AC +10/-15 % 24 V AC/DC +20/-15 %
Cable specification	Max. cable cross-section:	2.5 mm ² (≅14 AWG)
Power consumption	Max. 10 VA	
Insulation resistance between galvanically isolated circuits	276 Vrms	
Frequency	47 ... 64 Hz	
CPG310		
Supply voltage	Version CPC310-xxxx 0 xxxx Version CPC310-xxxx 1 xxxx Version CPC310-xxxx 8 xxxx	230 V AC +10/-15 % 110 ... 115 V AC +10/-15 % 24 V AC/DC +20/-15 %
Cable specification	Max. cable cross-section:	2.5 mm ² (≅14 AWG)
Power consumption	max. 12 VA	
Insulation resistance between galvanically isolated circuits	276 Vrms	
Frequency	47 ... 64 Hz	

11.4 Performance characteristics

Reference temperature	25 °C (77 °F), can be set with medium temperature compensation	
Measured value resolution	pH: Redox: Temperature:	0.01 pH 1 mV / 1 % 0.1 K
Maximum measured error¹⁾	Display: pH: Redox: Temperature	Max. 0.2 % of measuring range scope max. 1 mV max. 0.5 K
Repeatability¹⁾	Max. 0.1 % of measuring range	
Zero point shift	pH: Redox:	-2 ... +16 pH -200 ... +200 mV
Slope adjustment	pH:	5 ... 99 mV / pH
Offset	Redox: Temperature:	±120 mV ±5 K
Assignment for redox relative	Adjustable, Δ for 100 % = 150 ... 2000 mV	

1) In accordance with IEC 746-1, at nominal operating conditions

11.5 Environment

Ambient temperature range	-10 ... +55 °C (+14 ... +131 °F)
Ambient temperature limits	-20 ... +60 °C (-4 ... +140 °F)
Storage temperature	-30 ... +80 °C (-22 ... +176 °F)
Electromagnetic compatibility	Interference emission to EN 61326: 1997 / A1:1998; Class B resource (Housing sector) Interference emission to EN 61326: 1997 / A1:1998; Appendix A (Industry)
Degree of protection CPM153	IP 65
Degree of protection CPG310	IP 54
Relative humidity	10 ... 95%, non-condensing

11.6 Process

Temperature range media conveyed	0 ... 50 °C (32 ... 122 °F)
---	-----------------------------

11.7 Mechanical construction

Mycom S CPM153		
Design, dimensions	Length x breadth x depth: Installation depth:	247 mm x 167 mm x 100 mm (9.72" x 6.57" x 3.94") Approx. 134 mm (5.28")
Weight	Max. 6 kg (13.23 lbs)	
Material	Housing: Front:	GD-AISI 12 (Mg content 0.05%), plastic-coated Polyester, UV-resistant
Terminals	Conductor cross-section:	2.5 mm ² (≅14 AWG)
CPG310		
Design, dimensions	Housing: Length x breadth x depth: 5 liter canister: Length x breadth x depth: Req. installation height:	400 mm x 300 mm x 200 mm (15.8" x 11.8" x 7.87") 190 mm x 250mm x 150 mm (7.48" x 9.84" x 5.91") 350 mm (13.8")
Weight	Approx. 15 kg (33.1 lbs)	
Material	Housing: Hoses: Pump: Level probes: Canister:	Polyester GF PU, PTFE (wetted) PP, PVDF (wetted) Polypropylene HDPE

12 Appendix

12.1 Operating matrix

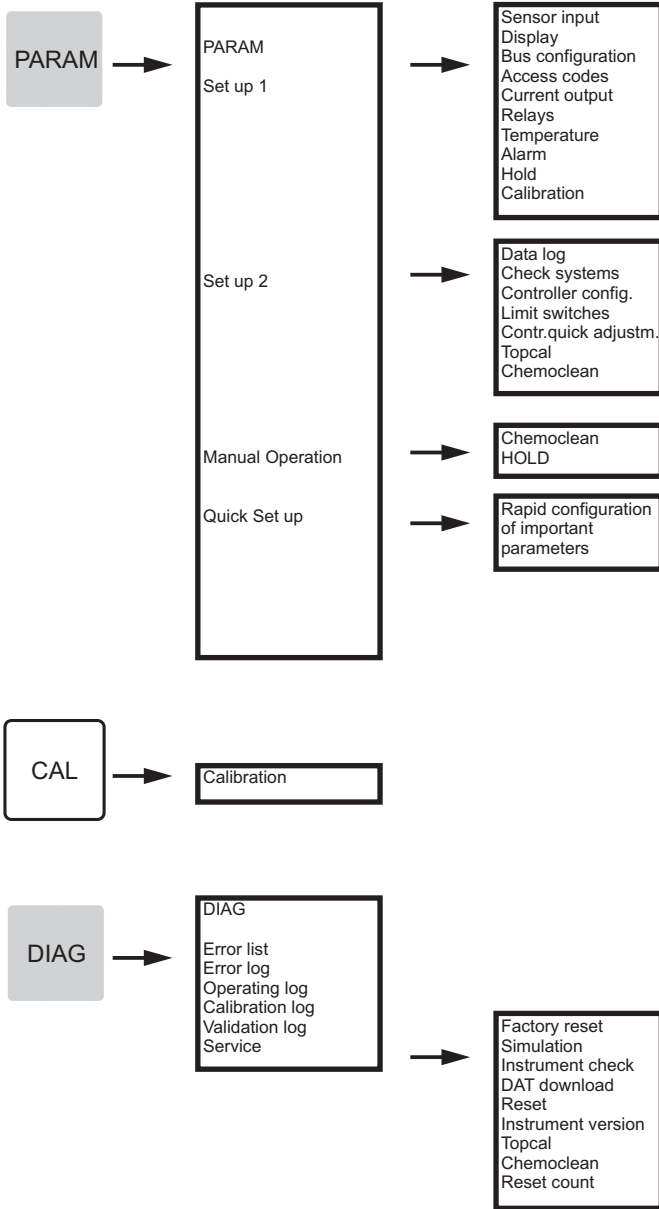

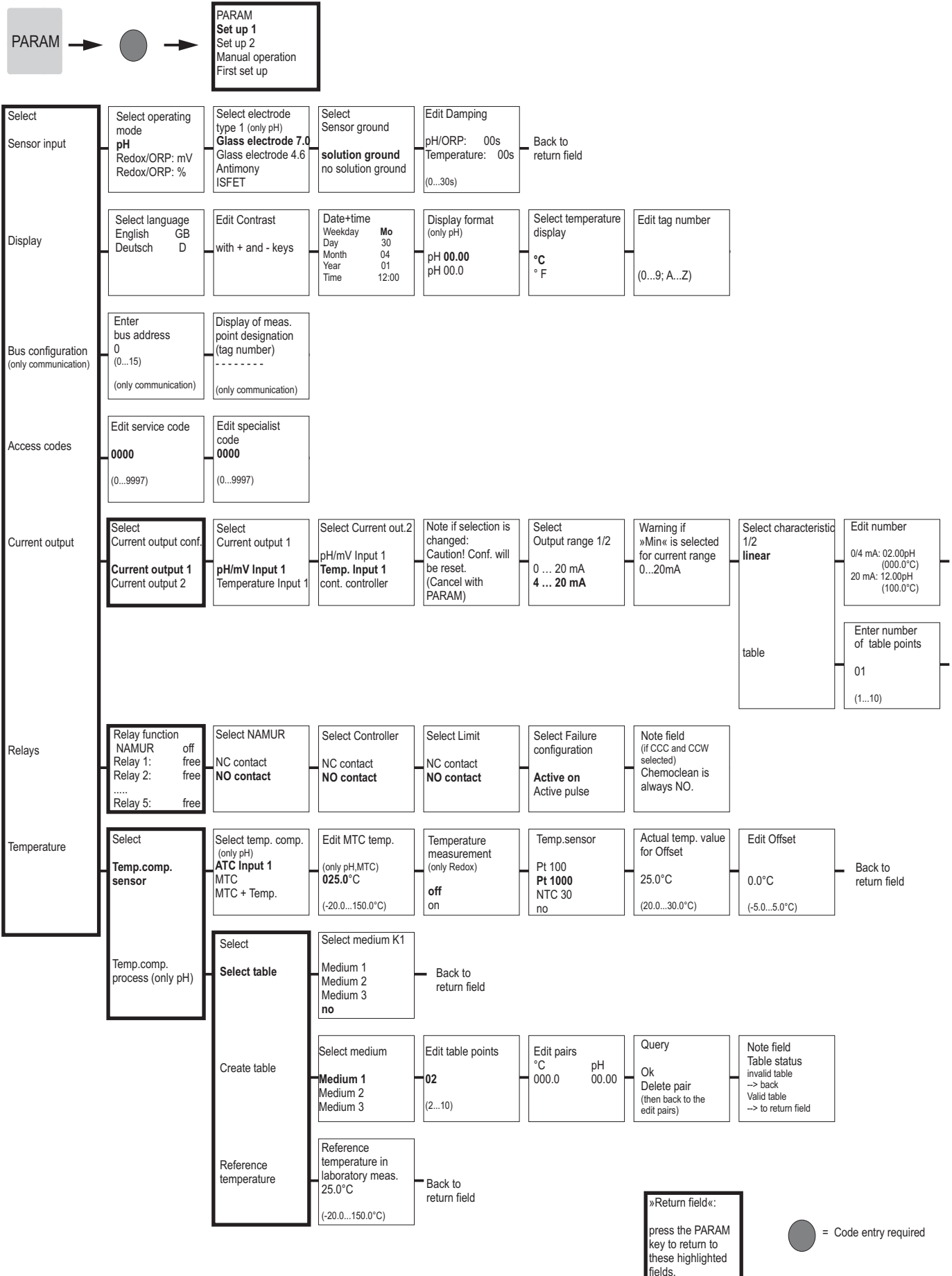

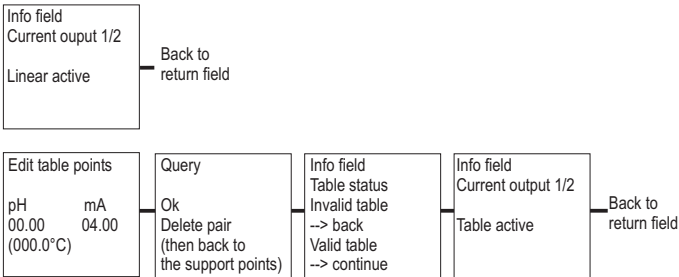

»Return field«:
press the PARAM
key to return to
these highlighted
fields..

 = Code entry required

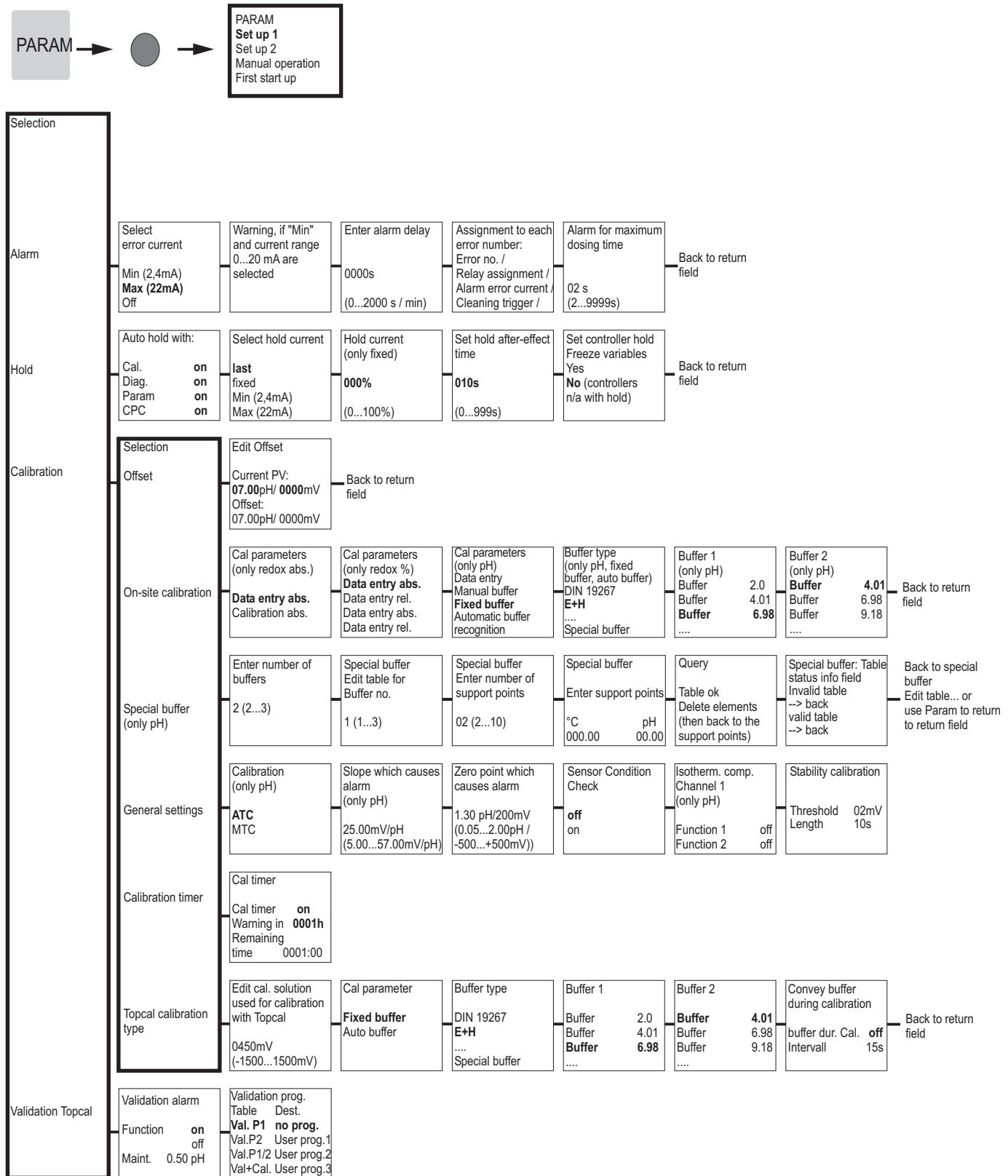

"Return field"
 Press the PARAM key to return to these highlighted fields

● = Code entry required

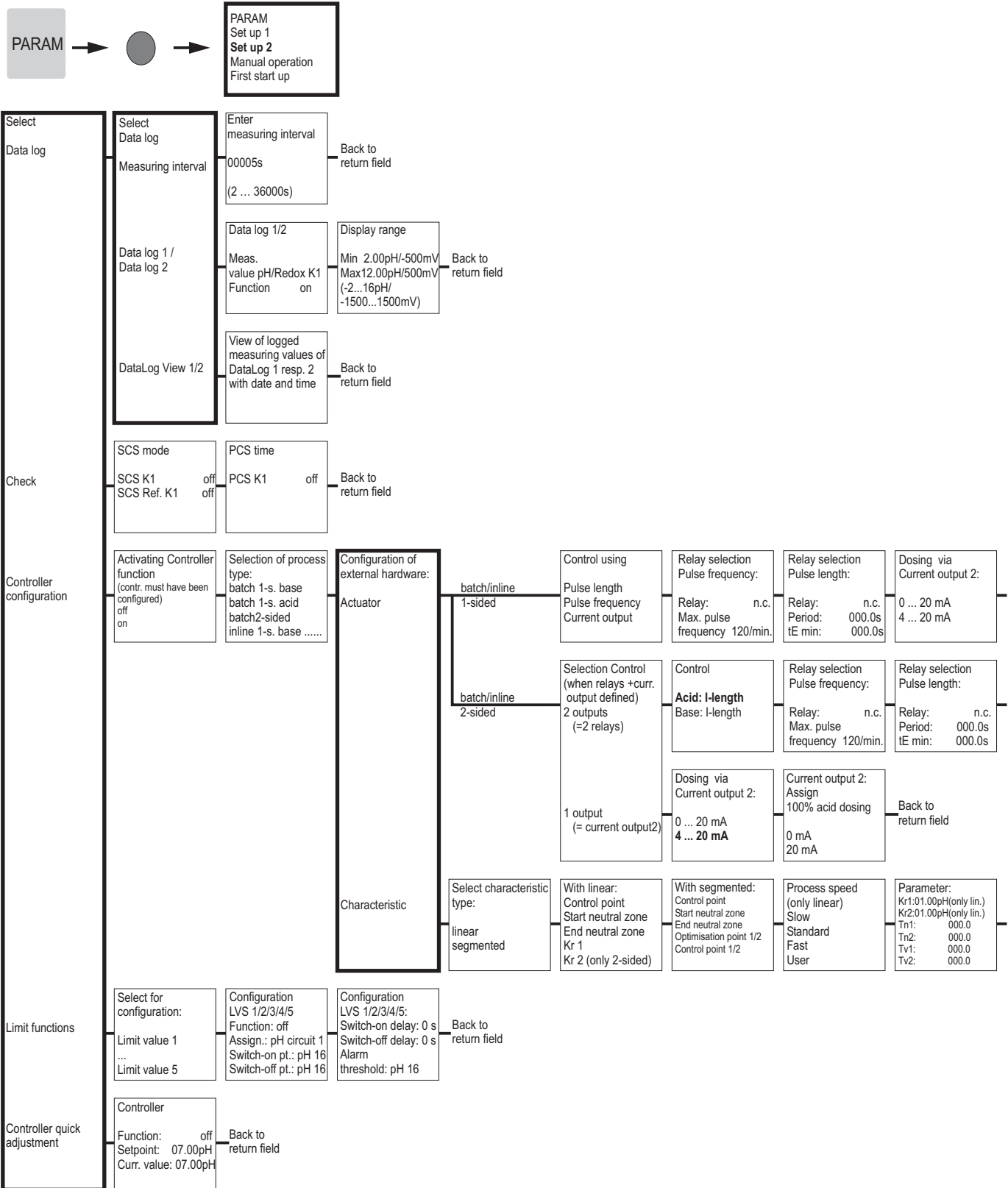

»Return field«:
press the PARAM key to return to the highlighted fields.

= Code entry required

Current output 2: Assign 100% acid dosing 0/4 mA 20 mA	Back to return field
--	-------------------------

Back to
return field

Activate controller simulation off on	Controller simulation Function auto Set: 07.00pH Act.: 07.00pH y: 000%	Controller simulation or back to return field
--	--	---

»Return field«:
press the PARAM
key to return to
the highlighted
fields.

 = Code entry required

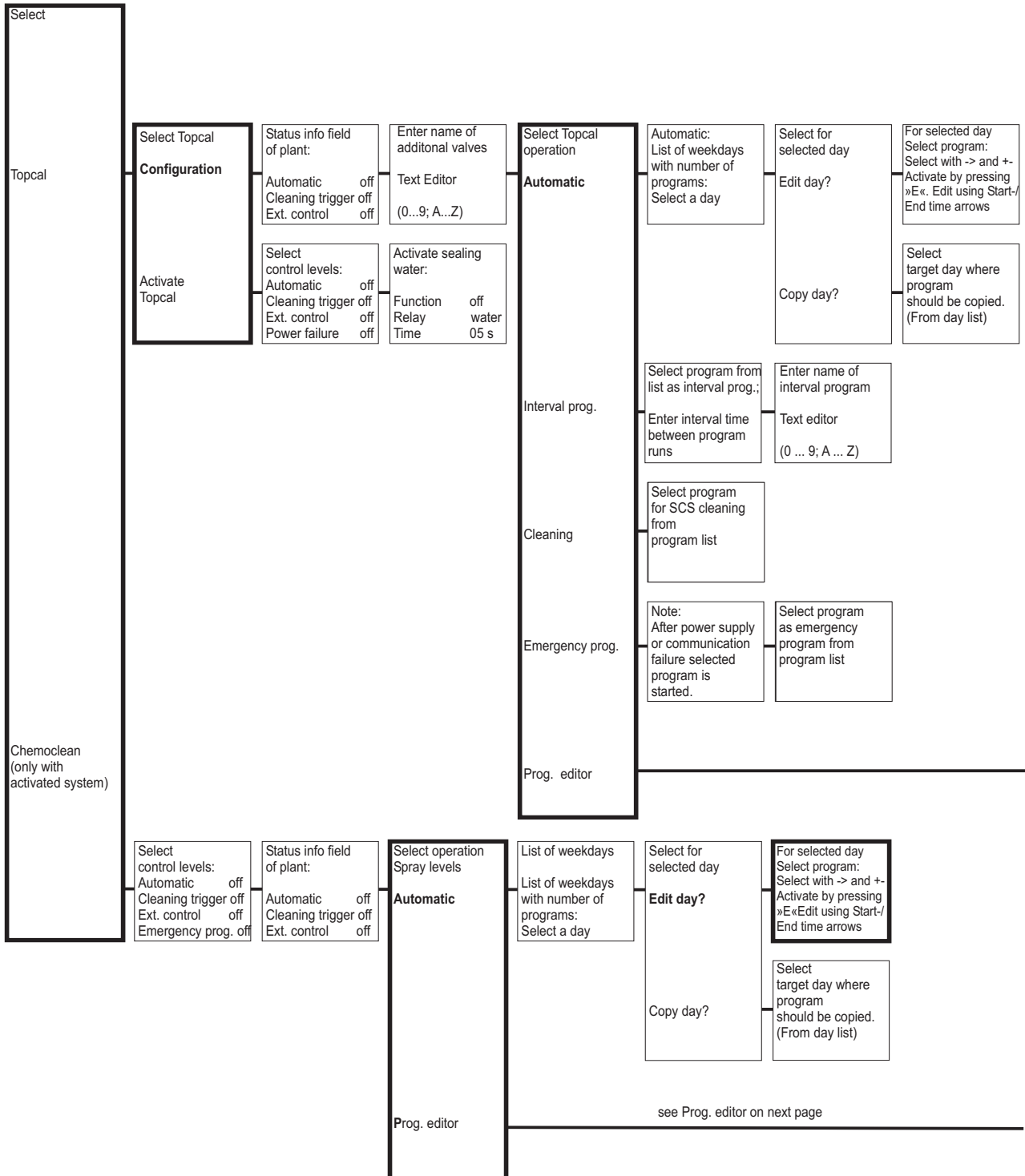
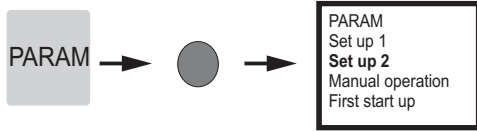

»Return field«:
press the PARAM key to return to the highlighted fields.

= Code entry required

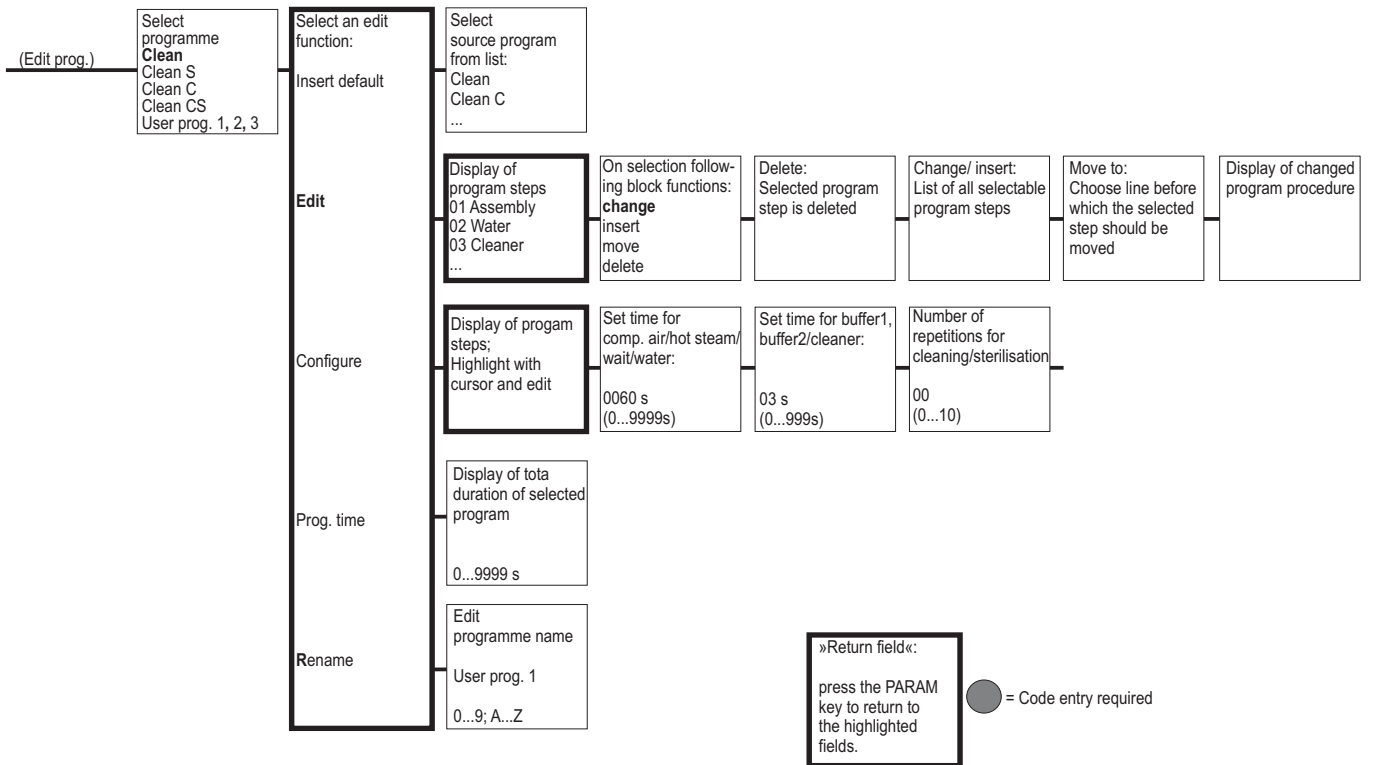

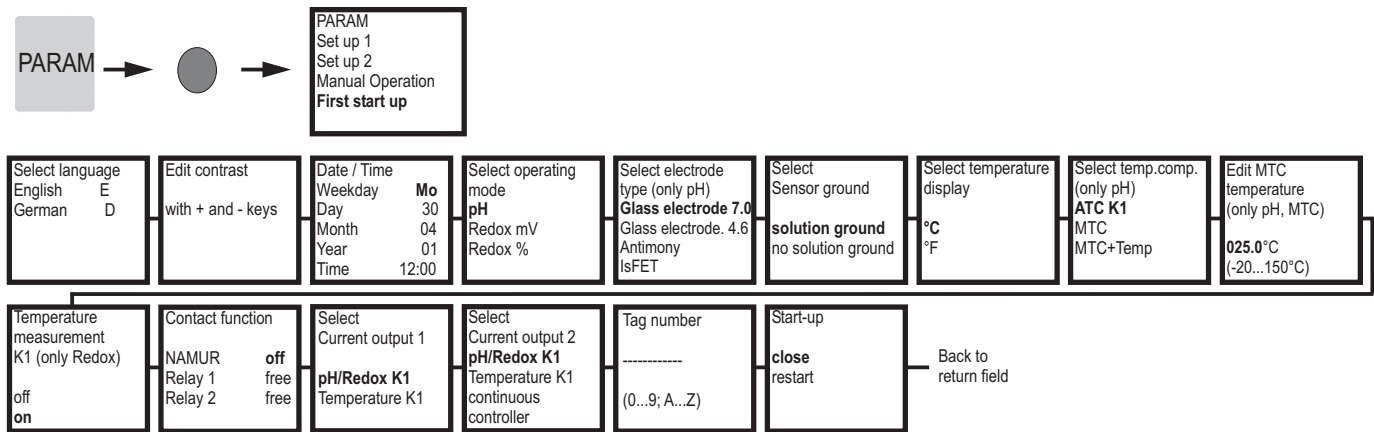
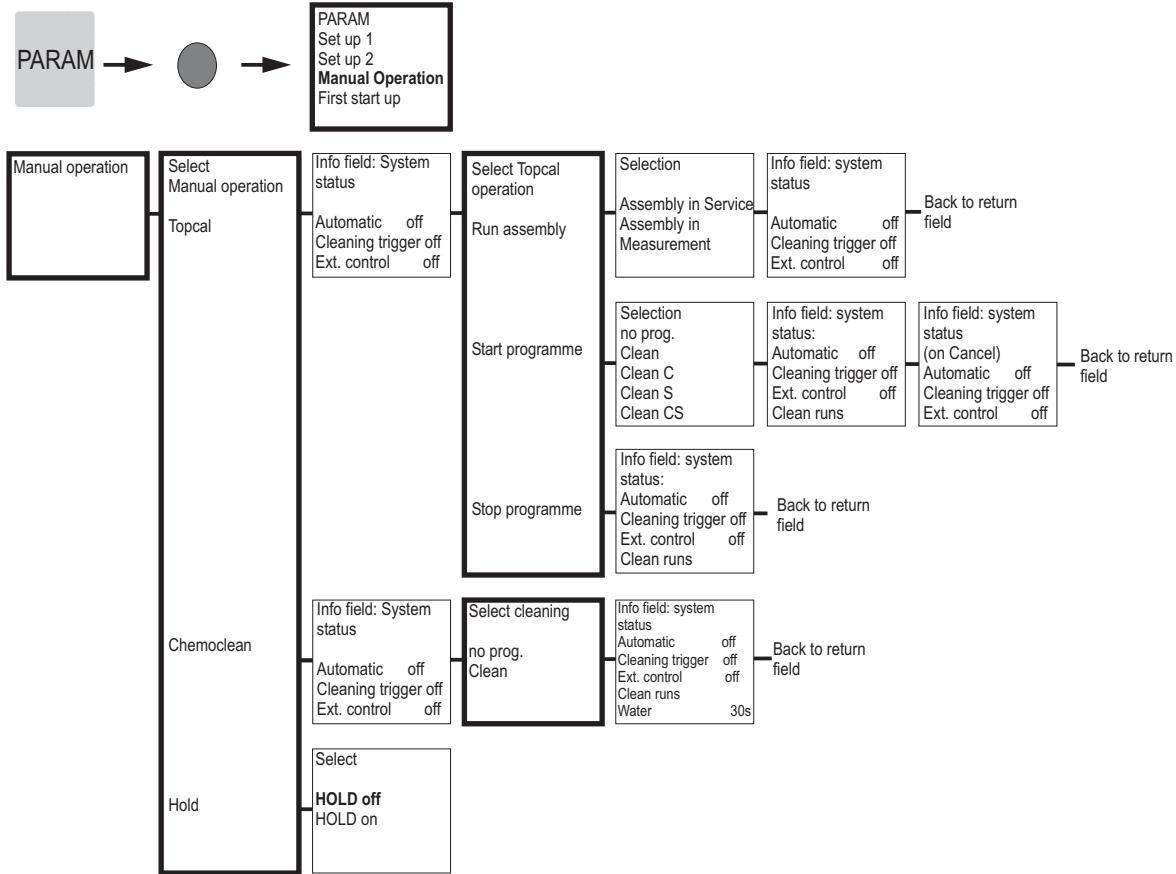

"Return field"
Press the PARAM
key to return to
these highlighted
fields.

[] = Code entry required

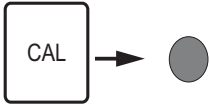

Sensor mode pH:								
Window info calibration type (selected in:PARAM) Set up 1(Calibration) Manual calibration): Cal with enter spec. buffer:	Enter temperature at which zero point and slope have been determined. 025.0°C (-20.0...150.0°C)	Data input: Zero point 07.00pH (-2.00...16.00pH) ISFET: curr.value(-/+500mV)	Edit slope 57.19mV/pH (5.00...99.00mV/pH)	Calibration Accept Reject Repeat calibration	Note: Electrode submersed?			
For cal with manual buffer:	Edit buffer temp. (only MTC) 025.0°C (-20.0...150.0°C)	Note: Start 1st buffer Immerse electrode in buffer 1	Edit buffer 1 Temp: 25.0°C 07.00 pH (-2.00...16.00pH)	Stability check buffer 1 If stable: press E	Note: Start 2nd buffer Immerse electrode in buffer 2	Edit buffer 2 Temp: 25.0°C 07.00 pH (-2.00...16.00pH)	Stability check buffer 2 If stable: press E	Electrode condition Electrode 1 good
	Note: Calibration result invalid--> Reject Recalibrate	Calibration Accept Reject Recalibrate	Note: Electrode submersed?					
For calibration with buffer table / auto buffer recogn.	Edit buffer temp. (only MTC) 025.0°C (-20.0...150.0°C)	Note: Start 1st buffer Immerse electrode in buffer 1	Stability check buffer 1 If stable: press E	Note: Start 2nd buffer Immerse electrode in buffer 2	Stability check buffer 2 If stable: press E	Identified buffers: (or calibration end) Buffer 1: Buffer 2: Buffer type:E+H	Electrode info: Zero point Condition Slope Condition	Electrode condition Electrode good
	Note: Calibration result invalid--> Reject Recalibrate	Calibration Accept Reject Recalibrate	Note: Electrode submersed?					
Sensor mode Redox abs. (mV):								
Window info calibration type (selected in:PARAM) Set up 1(Calibration) Manual calibration): for calibration with enter data abs.:	Enter offset 0000mV (-1500...1500.0mV)	Calibration Accept Reject Recalibrate	Note: Electrode submersed?					
For calibration with calibration abs.:	Note: Start 1st buffer Submerge electrode in buffer	Enter buffer 0225mV (-1500...1500mV)	Stability check buffer 1 If stable: press E	Calibration info electrode Offset 0000mV good	Note: Calibration result not valid	Calibration Accept Reject Recalibrate	Note: Electrode submersed?	
Sensor mode Redox rel. (%):								
Window info calibration type (selected in:PARAM) Set up 1(Calibration) Manual calibration): (for calibration with enter data abs. and with calibration abs. see above)								
For calibration with calibration rel.:	Note: Start 1st buffer Submerge electrode in buffer	Enter buffer 10% (0...30%)	Stability check buffer 1 If stable: press E	Note: Start 2nd buffer Submerge electrode in buffer	Enter buffer 2 10% (0...30%)	Stability check buffer 2 If stable: press E	Note: Voltage range too small	Note: Electrode submersed?
For calibration with enter data rel.:	Enter cal. points 1:0...30%: 20% 1: Voltage: 0600 mV 2: 70...100%: 80% 2: Voltage: -0600mV	Note: Electrode submersed?						

If you press the MEAS key, a message will appear asking if you want to abort the calibration.

= Code entry required

DIAG →

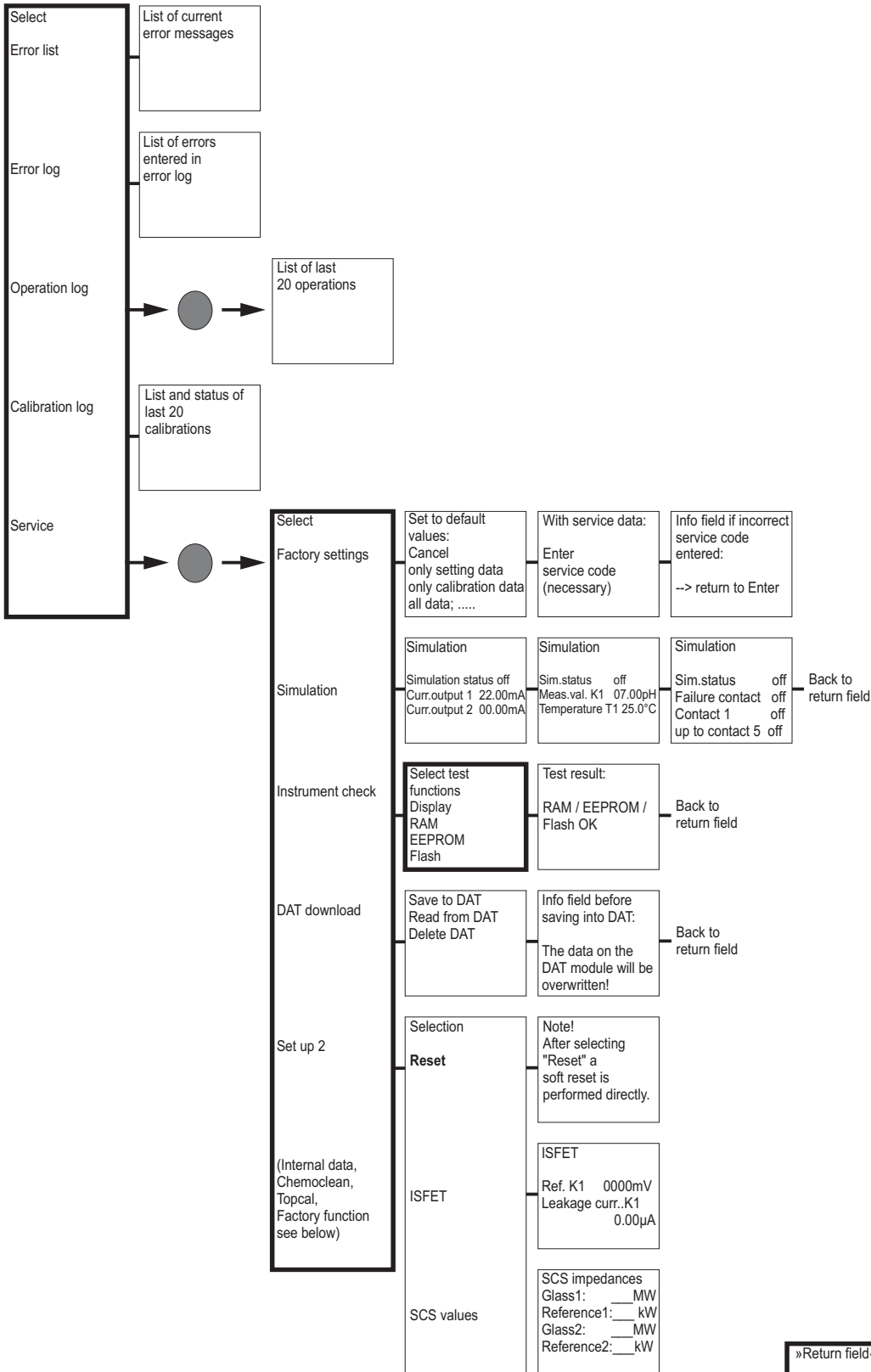

»Return field«:
press the PARAM key to return to the highlighted fields.

= Code entry required

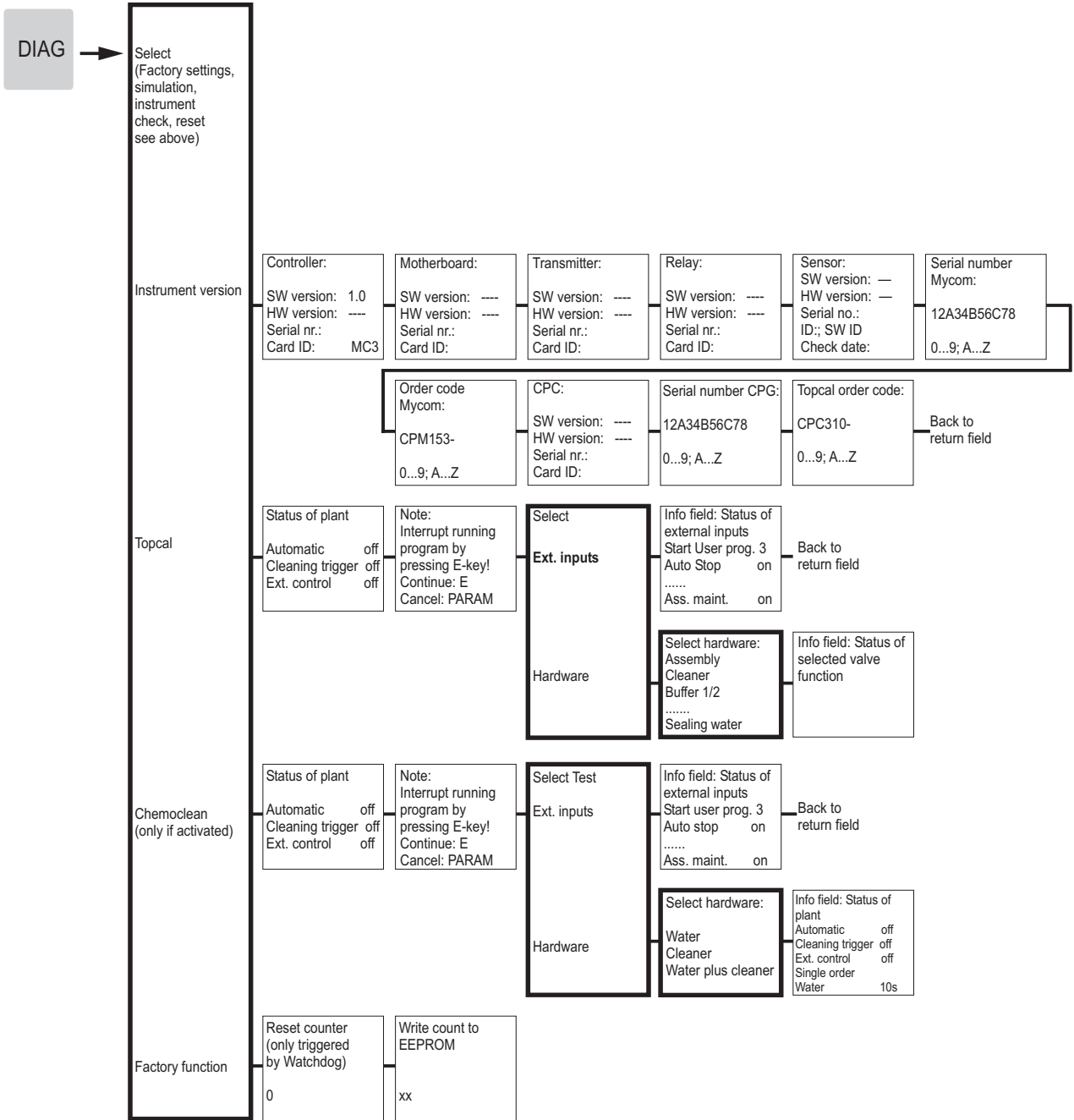

»Return field«:
press the PARAM key to return to the highlighted fields.

● = Code entry required

12.2 Connection examples

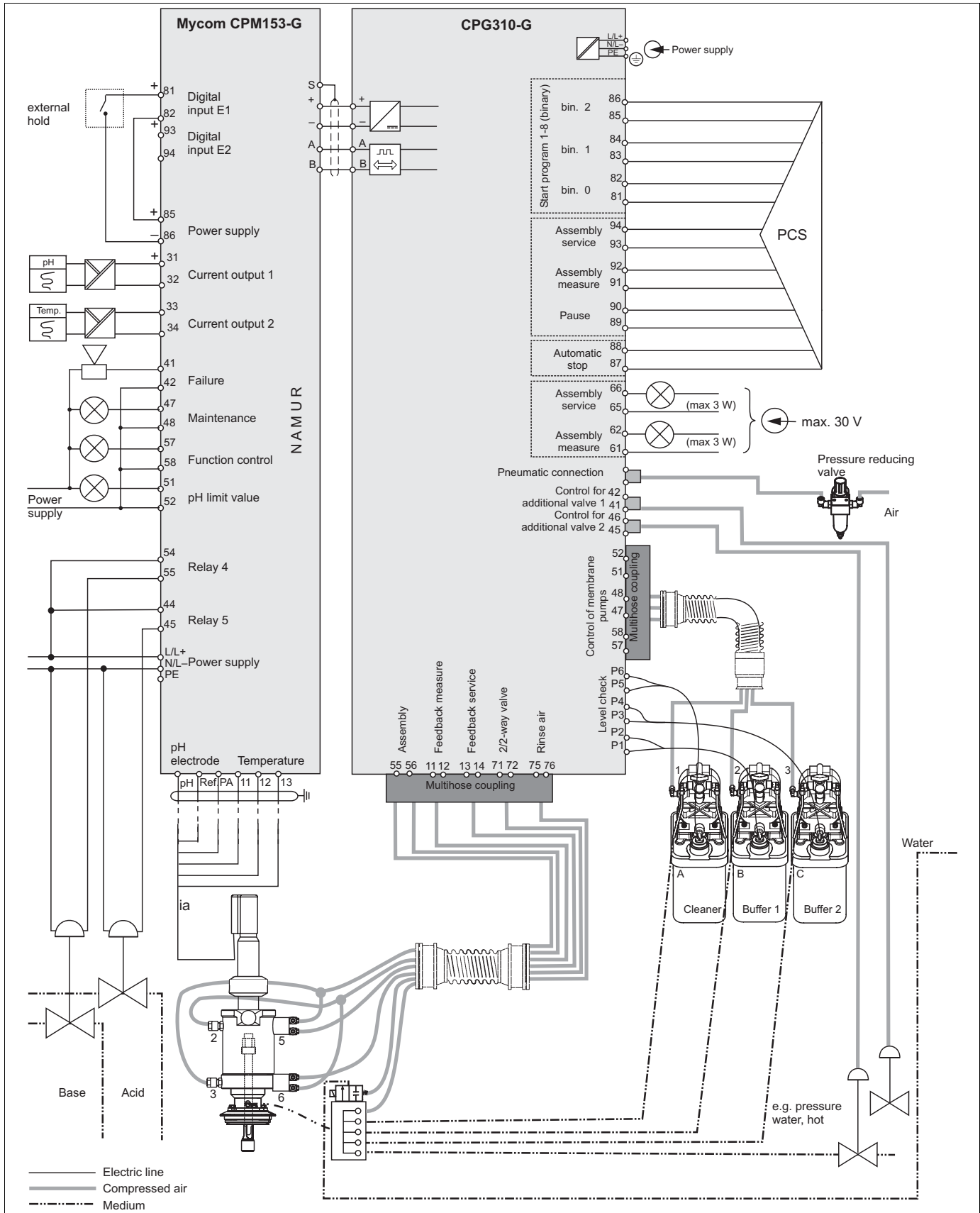

Fig. 76: Connection example, two-sided neutralization, limit value pH, NAMUR contact assignment, pH and temperature at current outputs, 2 additional valves, external control via PCS, assembly status display

12.3 Wiring example for external program start

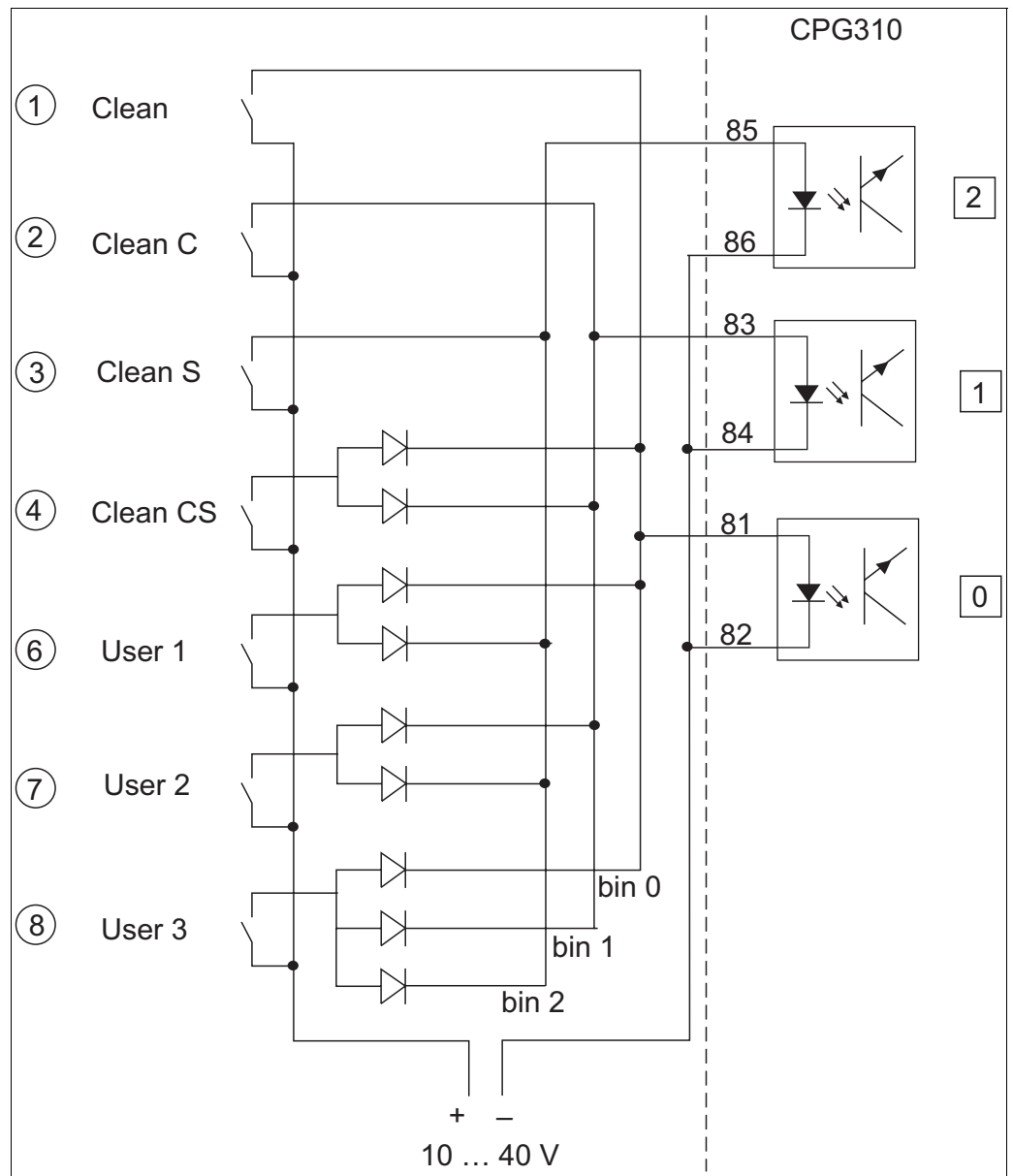

Fig. 77: Power diagram for external control of the cleaning and calibration programs

1-8 Buttons to start the cleaning programs

81-86 Terminals for program start

0/1/2 Binary inputs of the CPG310 control unit

10-40V e.g. via power supply input of Mycom S CPM153, terminals 85/86 (15 V)

Diodes 1N4007

3 mA Per optoelectronic coupler input

12.4 Buffer tables

The following buffer tables are stored in Mycom S CPM153.

DIN 19267

°C	0	5	10	15	20	25	30	35	40	45	50	55	60	65	70	75	80	85	90	95
pH	1,08	1,08	1,09	1,09	1,09	1,09	1,10	1,10	1,10	1,10	1,11	1,11	1,11	1,11	1,11	1,11	1,12	1,12	1,13	1,13
	4,67	4,67	4,66	4,66	4,65	4,65	4,65	4,65	4,66	4,67	4,68	4,69	4,70	4,71	4,72	4,73	4,75	4,77	4,79	4,82
	6,89	6,87	6,84	6,82	6,80	6,79	6,78	6,77	6,76	6,76	6,76	6,76	6,76	6,76	6,76	6,77	6,78	6,79	6,80	6,81
	9,48	9,43	9,37	9,32	9,27	9,23	9,18	9,13	9,09	9,04	9,00	8,96	8,92	8,90	8,88	8,86	8,85	8,83	8,82	8,81
	13,95	13,63	13,37	13,16	12,96	12,75	12,61	12,45	12,29	12,09	11,98	11,79	11,69	11,56	11,43	11,31	11,19	11,09	10,99	10,89

Mettler

°C	0	5	10	15	20	25	30	35	40	45	50	55	60	65	70	75	80	85	90	95
pH	2,03	2,02	2,01	2,00	2,00	2,00	1,99	1,99	1,98	1,98	1,98	1,98	1,98	1,98	1,99	2,00	2,00	2,00	2,00	2,00
	4,01	4,01	4,00	4,00	4,00	4,01	4,01	4,02	4,03	4,04	4,06	4,08	4,10	4,13	4,16	4,19	4,22	4,26	4,30	4,35
	7,12	7,09	7,06	7,04	7,02	7,00	6,99	6,98	6,97	6,97	6,97	6,98	6,98	6,99	7,00	7,02	7,04	7,06	7,09	7,12
	9,52	9,45	9,38	9,32	9,26	9,21	9,16	9,11	9,06	9,03	8,99	8,96	8,93	8,90	8,88	8,85	8,83	8,81	8,79	8,77

E+H

°C	0	5	10	15	20	25	30	35	40	45	50	55	60	65	70	75	80	85	90	95
pH	2,01	2,01	2,01	2,00	2,00	2,00	2,00	2,00	2,00	2,00	2,00	2,00	2,00	2,00	2,01	2,01	2,01	2,01	2,01	2,01
	4,05	4,04	4,02	4,01	4,00	4,01	4,01	4,01	4,01	4,01	4,00	4,00	4,00	4,00	4,00	4,00	4,00	4,00	4,00	4,00
	7,13	7,07	7,05	7,02	7,00	6,98	6,98	6,96	6,95	6,95	6,95	6,95	6,96	6,96	6,96	6,96	6,97	6,98	7,00	7,02
	9,46	9,40	9,33	9,28	9,22	9,18	9,14	9,10	9,07	9,04	9,01	8,99	8,96	8,95	8,93	8,91	8,89	8,87	8,85	8,83
	11,45	11,32	11,20	11,10	11,00	10,90	10,81	10,72	10,64	10,56	10,48	10,35	10,23	10,21	10,19	10,12	10,06	10,00	9,93	9,86

NBS/DIN 19266

°C	0	5	10	15	20	25	30	35	40	45	50	55	60	65	70	75	80	85	90	95
pH	1,67	1,67	1,67	1,67	1,68	1,68	1,69	1,69	1,70	1,70	1,71	1,72	1,73	1,74	1,74	1,76	1,77	1,79	1,80	1,81
	4,01	4,01	4,00	4,00	4,00	4,01	4,01	4,02	4,03	4,04	4,06	4,08	4,10	4,11	4,12	4,14	4,16	4,18	4,20	4,23
	6,98	6,95	6,92	6,90	6,88	6,86	6,85	6,84	6,84	6,83	6,83	6,84	6,84	6,85	6,85	6,86	6,86	6,87	6,88	6,89
	9,46	9,39	9,33	9,27	9,22	9,18	9,14	9,10	9,07	9,04	9,01	8,99	8,96	8,94	8,93	8,91	8,89	8,87	8,85	8,83

Merck + Riedel

°C	0	5	10	15	20	25	30	35	40	45	50	55	60	65	70	75	80	85	90	95
pH	2,01	2,01	2,01	2,00	2,00	2,00	2,00	2,00	2,00	2,00	2,00	2,00	2,00	2,00	2,01	2,01	2,01	2,01	2,01	2,01
	4,05	4,04	4,02	4,01	4,00	4,01	4,01	4,01	4,01	4,01	4,00	4,00	4,00	4,00	4,00	4,00	4,00	4,00	4,00	4,00
	7,13	7,07	7,05	7,02	7,00	6,98	6,98	6,96	6,95	6,95	6,95	6,95	6,96	6,96	6,96	6,96	6,97	6,98	7,00	7,02
	9,24	9,16	9,11	9,05	9,00	8,95	8,91	8,88	8,85	8,82	8,79	8,76	8,73	8,72	8,70	8,68	8,66	8,65	8,64	8,64
	12,58	12,41	12,26	12,10	12,00	11,88	11,72	11,67	11,54	11,44	11,33	11,19	11,04	10,97	10,90	10,80	10,70	10,59	10,48	10,37

Index

A

Access authorization	51
Access code	60
Accessories	120
Assemblies	122
Cables	120
DAT module	123
Housing CYC310	123
Junction boxes	120
Mounting outdoors	121
Offline configuration	123
Operating panel	125
Panel mounting	121
Sensors	120
Alarm	66

B

Buffer tables	162
---------------	-----

C

Calibration	108
pH	109
Redox	111
Calibration log	101
Calibration pH	
Manual buffer	109
Manual data input	109
calibration pH	
Automatic buffer recognition	109
Buffer table	109
Calibration programs	
Configuration	90
Controlling	85
Cycles	88
Calibration redox	
Absolute data input	111
Relative data input	112
Calibration settings	
pH	69
Redox	72
Certificates and approvals	9
Changeover, pH/ISFET	27
Check	75
Electrical connection	37
Function	53
Medium connection	48
Post-installation	17
Chemoclean	95
Cleaning	
Sensor	116
Transmitter	115
Cleaning programs	
Configuration	90
Configuration example	57
Controlling	85
Cycles	88

Code	60
Codes	51
Commissioning	5, 53
Digital sensors	53
ISFET sensors	53
Switching on	54
Configuration	59
Configuration of cleaning and calibration programs	90
Configuration of cleaning programs	90
Connection	
Analog sensors	24
Communication connection	22
Current outputs	30
Digital sensors	29
External inputs, control unit	32
External outputs	34
External outputs, control unit	32
Inductive limit position switch	35
Level probes	23
Overview	19
Power supply	22
Relay	31
Connection examples	160
Control	
1-sided	77
2-sided	77
Actuators	78
Characteristic	79
Pulse frequency	78
Pulse length	78
control unit	
Pneumatic	140
Control unit interior view	138
Control unit spare parts list	138
Controller configuration	77
Controller quick adjustment	85
Controlling cleaning and calibration programs	85
Current outputs	61
Coding	31
CYC310	123

D

DAT module	105
Data log	74
Declaration of conformity	9
Designated use	5
Device configuration	59
Device designation	7
Device fuse	142
Diagnosis	101
Differential conductivity	87
Display	49, 60
Disposal	143

E

Editor types	52
Electrical connection	19

Electrical symbols	6
Electrical technician	18
Electrode connection	24
Electromagnetic compatibility	5
Environment	146
Error	
System errors	127
Error log	101
Error messages	127
Errors	
Device-specific errors	134
Process-specific errors	131
Troubleshooting	127
F	
Function of keys	49
H	
Hold	67
I	
Icons	6
Immediate commissioning	54
Incoming acceptance	10
Input	144
Installation	5, 10
Instructions	13
Installation conditions	
Assembly	11
Dimensions	12
Spacing	11
Types of mounting	10
Installation instructions	
Panel mounting	15
Post mounting	15
Wall mounting	14
K	
Key function	49
L	
Limit switch	83
M	
Maintenance	115
Assembly	118
Cables	118
Connections	118
Control unit	119
Digital sensors	117
Liquid KCl supply	117
Overall measuring point	115
Power supply lines	118
Manual operation	99
Measured value display	51
Mechanical construction	146
Medium connection	38
Assemblies	40
Cleaner and buffer	46
Compressed air	46

Rinse water	46
Mycom interior view	137
Mycom spare parts list	137

N

Nameplate	7
NAMUR	32
Notes on safety conventions and icons	6

O

Offline configuration	123
Operating matrix	147
Operation	5, 49
Operation log	101
Operational safety	5
Ordering	8
Output	144
Output error response mode	135

P

Panel mounting	15
PCS	76
Performance characteristics	145
pH/ISFET changeover	27
Pneumatic control unit	140
Post mounting	15
Post-connection check	37
Post-installation check	17
Power supply	145
Process	146
Process Check System	76
Product structure	8
Program cycles	88
Pulse frequency	78
Pulse length	78

Q

Quick Setup	54
-----------------------	----

R

Redox calibration	
Absolute	111
Relative	113
Relays	63
Replacing device fuse	142
Return	6, 143

S

Safety conventions	6
Safety instructions	5
Scope of delivery	7
SCS	75
Sensor Check System	75
Sensor connection	24
Sensor data	
Digital sensors	101
Sensor input	59
Service switch	50
Set up 1	
Alarm	66

Calibration.....	69
Code.....	60
Current outputs.....	61
Display.....	60
Hold.....	67
Relays.....	63
Sensor input.....	59
Temperature.....	64
Validation function.....	74
Set up 2	
Check.....	75
Chemoclean.....	95
Controller configuration.....	77
Controller quick adjustment.....	85
Data log.....	74
Limit switch.....	83
Topcal.....	85
Spare parts.....	136
Storage.....	10
Symbols	
Electrical.....	6
T	
Technical data.....	144–146
Process.....	146
Temperature compensation.....	64
Medium temperature.....	64
Transport.....	10
Troubleshooting.....	127
U	
Use.....	5
V	
Validation function.....	74
W	
Wall mounting.....	14
Wiring.....	18
External program start.....	161

www.endress.com/worldwide

Endress+Hauser 
People for Process Automation

