

Technical Information

Liquistation CSF34

Automatic stationary sampler for liquid media
Integrated controller with up to four measuring channels
and optional digital Memosens technology



Application

Liquistation CSF34 is a stationary sampler designed for the fully automated removal, defined distribution, and temperature-controlled storage of liquid media. The standard product version has two 0/4 to 20 mA analog inputs, two binary inputs and two binary outputs. Thanks to the modular platform concept, the CSF34 can be quickly and easily modified to create a measuring station.

The sampler is designed for use in the following applications:

- Municipal and industrial sewage treatment plants
- Laboratories and Water Conservancy Boards
- Monitoring of liquid media in industrial processes

Your benefits

- All purpose plastic ASA-PC housing material
- Two-door housing for reliable sample temperature regulation
- Air circulation in both the upper and lower enclosure
- Swift menu guidance, navigator and large display
- Dual bottle trays for easy sample transportation
- Practice-oriented programs ranging from simple time programs to event programs
- Functionality can be extended by installing modular electronic components
- Integrated data logger for recording measured values
- Service interface for data transmission
- Optional battery backup system ensures uninterrupted operation in the event of power failure

Contents

Function and system design	4	Protocol-specific data	20
Liquistation CSF34 sampler	4	HART	20
Sampler with online measurement	5	PROFIBUS-DP	20
Mode of operation with a vacuum pump	6	Modbus RS485	21
Mode of operation with a peristaltic pump	8	Modbus TCP	21
Sampling with a flow assembly	9	Web server	21
Sample distribution	10	Power supply	21
Sample preservation	10	Electrical connection	21
Sampling control	11	Supply voltage	21
Intake speed with different suction lines	11	Cable entry	21
Sample temperature regulation	12	Mains fuse	22
Equipment architecture	13	Power consumption	22
Slot and port assignment	13	Power failure	22
Communication and data processing	14	Performance characteristics	22
Dependability	14	Sampling methods	22
Reliability	14	Dosing volume	22
Maintainability	15	Dosing accuracy	22
Safety	17	Repeatability	22
Input	17	Intake speed	22
Input types	17	Suction height	22
Measured variables	17	Hose length	22
Temperature inputs	17	Temperature control	23
Measuring range	17	Installation	23
Input type	17	Installation instructions	23
Accuracy	17	Mounting conditions for Liquistation CSF34	24
Binary input, passive	17	Environment	24
Span	17	Ambient temperature range	24
Signal characteristics	17	Storage temperature	24
Analog input, passive/active	17	Degree of protection	24
Span	17	Electromagnetic compatibility	24
Accuracy	17	Electrical safety	24
Output	18	Relative humidity	24
Output signal	18	Process	25
Signal on alarm	19	Medium temperature range	25
Load	19	Medium properties	25
Linearization/transmission behavior	19	Process pressure (absolut)	25
Current outputs, active (optional)	19	Process connection	25
Relay outputs (optional)	19	Mechanical construction	25
Electrical specification of relay types	19	Dimensions	25
		Weight	26
		Material	26
		Operability	27
		Operating concept	27
		Display	27
		Local operation	27
		Remote operation	28
		Communication	29
		Software	29

Ordering information	30
Product structure	30
Scope of delivery	30
Certificates and approvals	30
CE mark	30
MCERTS	30
cSAus	30
Accessories	31
Accessories for Liquistation CSF34	31
Sensors	32
Measuring cable	35

Function and system design

Liquistation CSF34 sampler

A complete sampling unit comprises:

Liquistation CSF34 for open channels include the following, depending on version:

- Controller with display, soft keys and navigator
- Vacuum or peristaltic pump for sampling
- PE or glass sample bottles for sample preservation
- Sampling chamber temperature regulator for safe sample storage
- Suction line with suction head

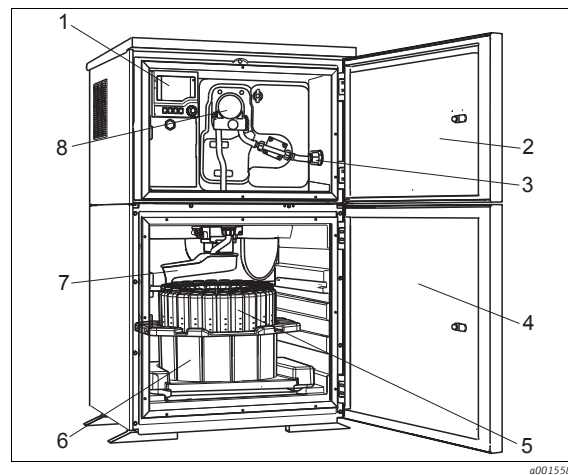

- 1 Controller
- 2 Dosing compartment door
- 3 Suction line connection
- 4 Sampling compartment door
- 5 Sample bottles, e.g. 24 PE 1 liter bottles
- 6 Bottle trays (depending on the sample bottles selected)
- 7 Distribution arm
- 8 Peristaltic pump

Example of a Liquistation CSF34, version with peristaltic pump

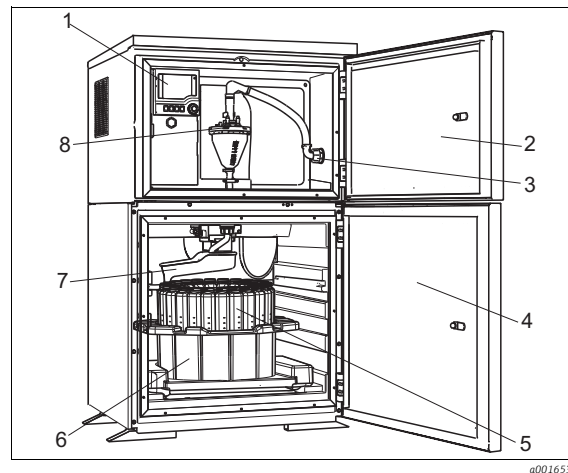

- 1 Controller
- 2 Dosing compartment door
- 3 Suction line connection
- 4 Sampling compartment door
- 5 Sample bottles, e.g. 24 PE 1 liter bottles
- 6 Bottle trays (depending on the sample bottles selected)
- 7 Distribution arm
- 8 Vacuum system, e.g. dosing system with conductive sample sensor

Example of a Liquistation CSF34, version with vacuum pump

Sampler with online measurement

i The following overview shows examples of the design and layout of a measuring system. Other sensors and assemblies can be ordered for conditions specific to your application. See Accessories section and also --> www.endress.com/products

Measuring point

A complete measuring system with online measurement consists of:

- Liquistation CSF34 sampler
- Sensors with Memosens technology
- Immersion or flow assemblies to suit the sensors used

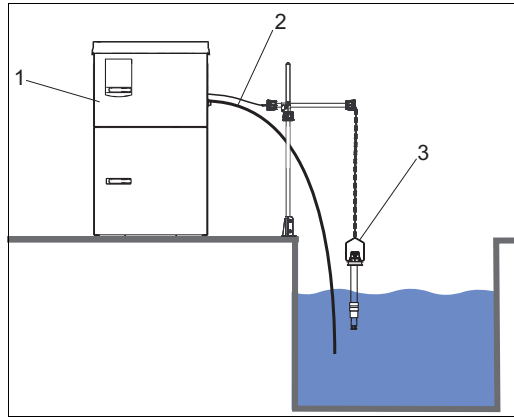

Measuring system

- 1 Liquistation CSF34
- 2 Suction line
- 3 Sensors with immersion assembly

Nitrate

- Viomax CAS51D sensor with fixed cable
- Flexdip CYA112 assembly
- Flexdip CYH112 holder

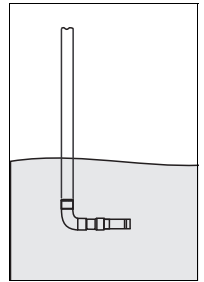

a0013297

Conductivity

Inductive conductivity measurement

- Flexdip CYA112 immersion assembly
- Indumax CLS50D sensor with fixed cable

Conductive conductivity measurement

- Flexdip CYA112 immersion assembly
- Condumax CLS15D sensor

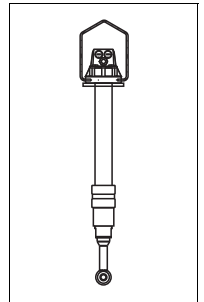

a0013346

Oxygen

- Flexdip CYA112 immersion assembly
- Flexdip CYH112 holder
- Sensor
 - Oxymax COS61D (optical) with fixed cable,
 - Oxymax COS51D (amperometric) cable CYK10

Figure: CYA112 with COS61D

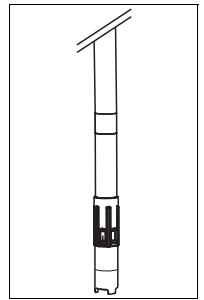

a0012415

pH value or ORP

- Retractable assembly Cleanfit CPA471
- Orbisint CPS11D, CPS12D sensor
- Measuring cable CYK10

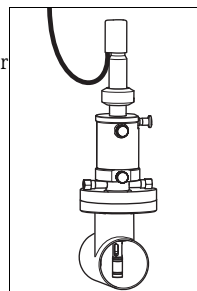

a0012413

Turbidity

- Flexdip CYA112 immersion assembly
- Spray head CUR4 (optional)
- Turbimax CUS51D sensor with fixed cable

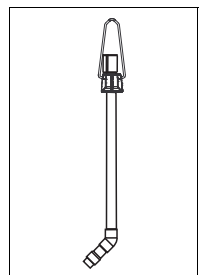

a0013294

- Flexdip CYA112 immersion assembly
- Orbisint CPS12D, CPS11D sensor
- Measuring cable CYK10

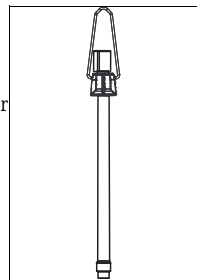

a0012787

- Flowfit CUA250 flow assembly
- Turbimax CUS51D sensor with fixed cable

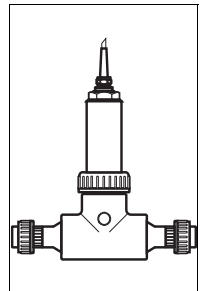

a0012788

Mode of operation with a vacuum pump

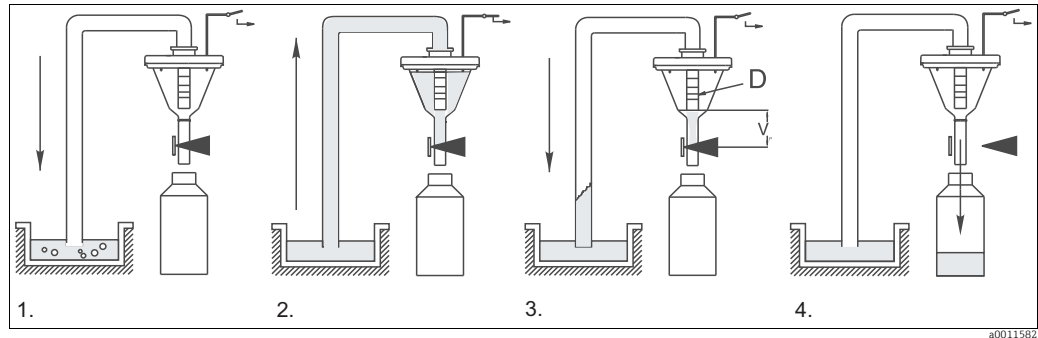

Sampling with a vacuum pump

Sampling takes place in four steps:

1. **Blow clear**
The hose valve is closed. The vacuum pump blows the suction line clear via the dosing system.
2. **Intake**
The "air manager" - a pneumatic control unit - switches the air path of the vacuum pump to "intake". The sample is drawn into the dosing beaker under vacuum. The level of liquid reaches the detectors of the dosing system.
3. **Dose**
The intake process is completed and pressure compensation takes place. Depending on the position of the dosing tube (D), the excess sample liquid flows back to the sampling point.
4. **Drain**
The hose clamp is opened and the sample is drained into the sample bottle.

Dosing system with conductive sample sensor

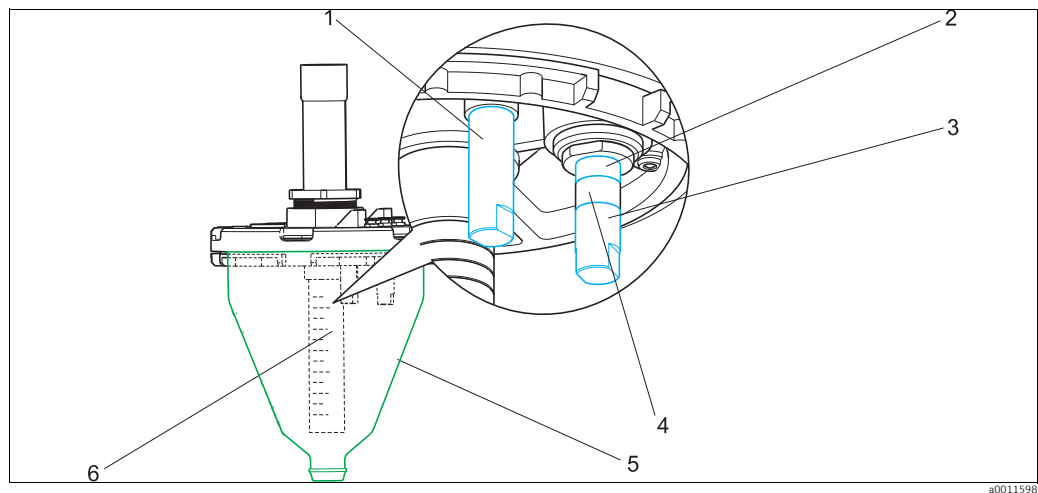

Conductive dosing system

- 1 Conductivity sensor 1 (common electrode)
- 2 Conductivity sensor 2 (safety electrode)
- 3 Conductivity sensor 3 (standard electrode)
- 4 Insulation
- 5 Dosing beaker (plastic version with graduated scale or glass)
- 6 Graduated dosing tube, white and blue scale

Not shown since hidden: hose connection for vacuum pump --> graphic for "Capacitance dosing system"

Level detection principle

When the sample is drawn in, the sample level reaches conductivity sensors 1 and 3. The system thus detects that the dosing beaker is filled and terminates the suction process.

If sensor 3 is heavily fouled or fails, conductivity sensor 2 switches to safety mode and turns off the system. This patented sample detection method along with predictive maintenance information prevent vacuum pump failure as a result of flooding.

Dosing system with capacitance sample sensor

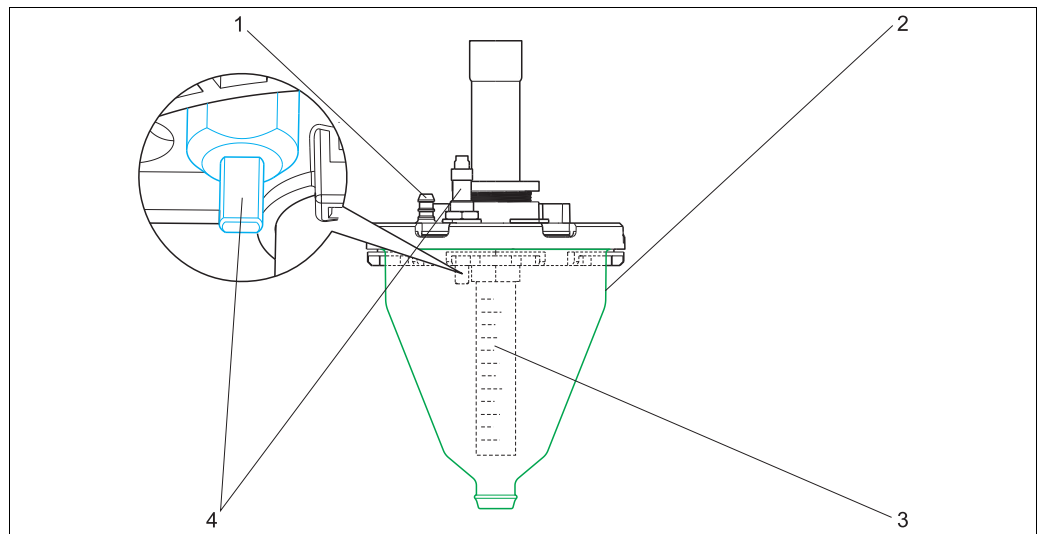

Capacitance dosing system

- 1 Hose connection for the vacuum pump
- 2 Graduated dosing beaker
- 3 Graduated dosing tube, white and blue scale
- 4 Capacitance level sensor

Level detection principle

When the level of medium in the dosing beaker changes, the capacitance of a capacitor partly formed by the liquid also changes.

The capacitance sensor ensures rapid sample detection in foaming media and media with a high fat content as well as in media with a conductivity $< 30 \mu\text{S}/\text{cm}$. In the case of the latter, only capacitance level detection is possible.

i Sample dosing with/without pressure

Sample dosing without pressure is the factory setting for all standard applications in which the sample medium is taken from an open channel or a gravity line. The excess sample can flow back under atmospheric pressure.

Sample dosing with pressure is selected for applications in which the sample is taken from a pipe, or for applications involving a low suction height and a low sample volume. In such instances, the sample medium cannot flow back on its own. The maximum pressure in the pipe must be $< 0.8 \text{ bar}$. Pressure is applied and the excess sample is forced out of the dosing beaker and back to the sampling point.

The sampling volume is set by adjusting the dosing tube. The white "A" scale applies if dosing without pressure, and the blue "B" scale applies if dosing with pressure.

Mode of operation with a peristaltic pump

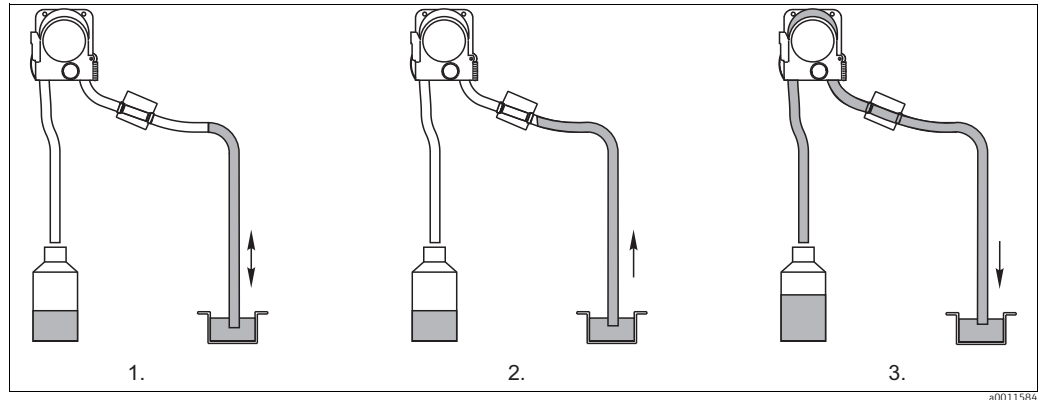

Sampling steps with a peristaltic pump

Sampling takes place in three steps:

1. **Rinse**
The peristaltic pump runs in reverse and forces medium back to the sampling point.
2. **Intake**
The peristaltic pump runs forward and draws in medium. If the medium detection system detects the sample, the pump is controlled by the flow and the specified sample volume is calculated automatically.
3. **Drain**
The pump runs in reverse again and forces the medium back to the sampling point.

One advantage this system offers for obtaining a representative sample is the possibility of rinsing the suction line several times:

Medium is initially drawn in until the medium detection system reacts, then the pump switches and forces the medium back to the sampling point. This process can be repeated a maximum of three times. The sample is then taken as described.

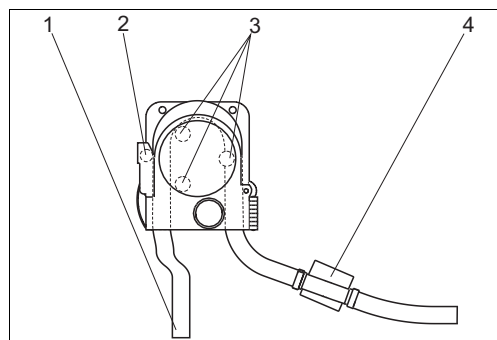

- 1 Pump tubing
- 2 Safety switch (optional)
- 3 Pump rollers
- 4 Medium detection system (patented)

Peristaltic pump

The pump rollers deform the hose, thereby causing a negative pressure and the suction effect. The medium detection system is based on a pressure sensor which detects the difference between a pipe that is filled and not filled.

Thanks to a patented process for automatically detecting the suction height, the user does not have to enter the suction height or suction line length. The self-learning software guarantees that the sample volume remains constant.

An optional safety switch integrated in the pump housing immediately switches off the pump when the pump is opened (recommended if third-party staff are performing maintenance work).

Sampling with a flow assembly

A flow assembly is integrated in the stand for sampling purposes.

The flow assembly is used when sampling in pressurized systems, e.g.:

- Containers located at a higher level
- Pressurized pipes
- Pumping with external pumps

The flow rate should be 1000 to 1500 l/h.

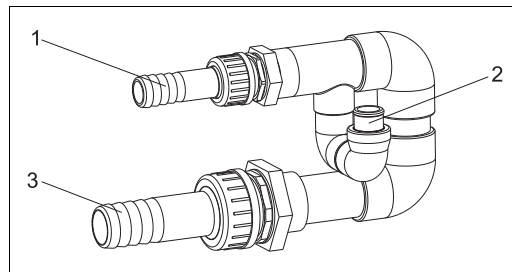

- 1 Flow assembly inlet: 3/4"
- 2 Sample connection
- 3 Flow assembly outlet: 1 1/4"

a0013127

Flow assembly

(can also be ordered separately as kit no.: 71119408)

- i** The outlet of the flow assembly must be unpressurized (e.g. drain, open channel)!

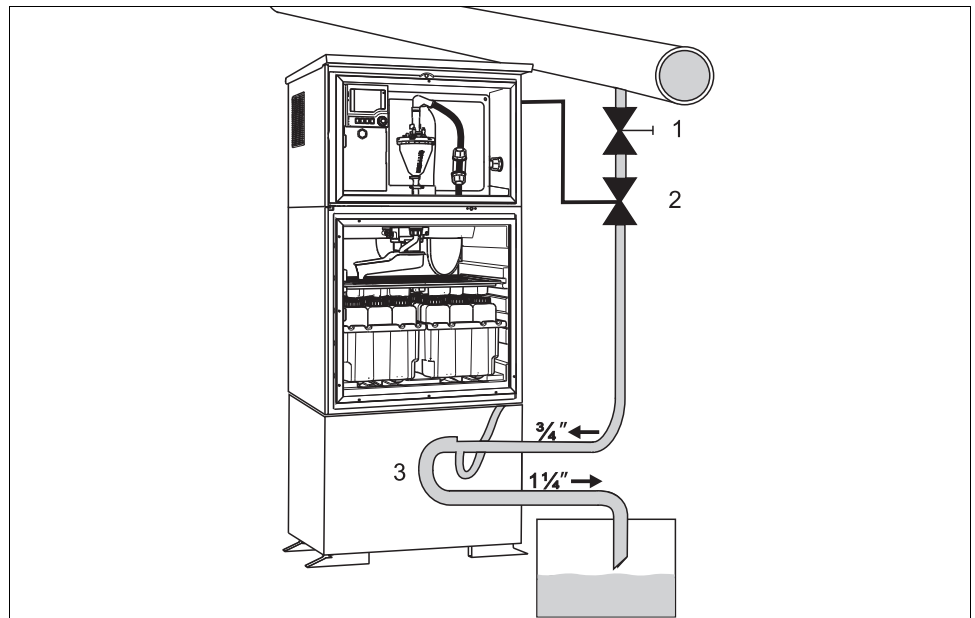

a0013458

Example: Sampling from pressure piping

- 1 Ball valve 1
- 2 Valve 2
- 3 Flow assembly integrated into the stand

Use the ball valve 1 to set the flow rate to 1000 l/h to 1500 l/h. When the sampling cycle begins, you can use one of the relay outputs to control and open valve 2. The medium flows through the pipe and the flow assembly into the outflow. When an adjustable delay time has elapsed, the sample is taken directly from the flow assembly. Valve 2 is closed again once the sample has been taken.

- i** Valve 1 and 2 are not included in the scope of delivery (order code: 71180379).

Sample distribution

CSF34 offers a wide range of bottle combinations and distribution versions. The versions can be changed or replaced easily without the need for special tools. In addition, the software program makes it possible to configure individual bottles and bottle groups and assign them to switchover or event programs.

Sample preservation

The sample bottles are located in the sample compartment. This is fitted with a seamless plastic dish to ensure easy cleaning.





All parts that transport medium (distribution arm, dosing system, distribution plate...) can be removed and cleaned easily without the need for tools.

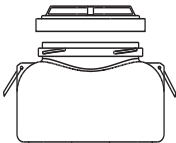

a0015209

Distribution plate, bottle trays and rotary arm

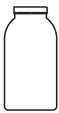
Bottle groups and distribution version depending on the order version:

		CSF34-*****							
		B	C	D	E	I	F	G	H
	30 liter, PE, direct distribution	1							
	60 liter, PE, direct distribution		1						
	25 liter, PE, direct distribution			2					
	13 liter, PE, direct distribution				4				
	3.8 liter, glass, direct distribution					4			
	2 liter, PE, direct distribution						1 2		6
	1 liter, PE, direct distribution							2 4	1 2

Sampling control

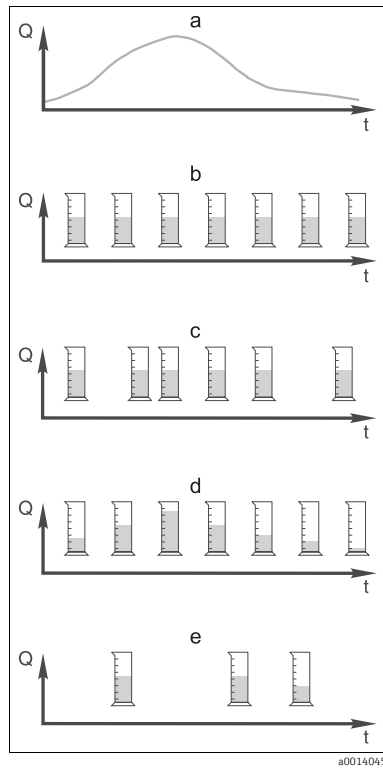

Sampling control

- a. Flow curve
- b. **Time-proportional sampling**
A constant sample volume (e.g. 50 ml) is taken at regular intervals (e.g. every 5 min).
- c. **Volume-proportional sampling**
A constant sample volume is taken at variable intervals (depending on the inflow volume).
- d. **Flow-proportional sampling**
A variable sample volume (the sample volume depends on the inflow) is taken at regular intervals (e.g. every 10 min).
 Only in version with peristaltic pump.
- e. **Event-controlled sampling**
Sampling is triggered by an event (e.g. pH limit value).
Sampling can be time-paced, volume-paced or flow-paced, or single samples can be taken.

Single and multiple samples can also be grouped in a program in addition to the sampling methods listed. Furthermore, the software allows interval sampling, switchover and event functions. The latter permit up to 24 subprograms to be active simultaneously for a variety of applications. A sampling table makes it possible for users to program the bottle assignment, time interval and sample volume. Signals for external control can be connected via 2 analog inputs and 2 binary inputs in the standard version of the product. Customized text is entered to ensure the correct assignment of the inputs in the memory.

Intake speed with different suction lines

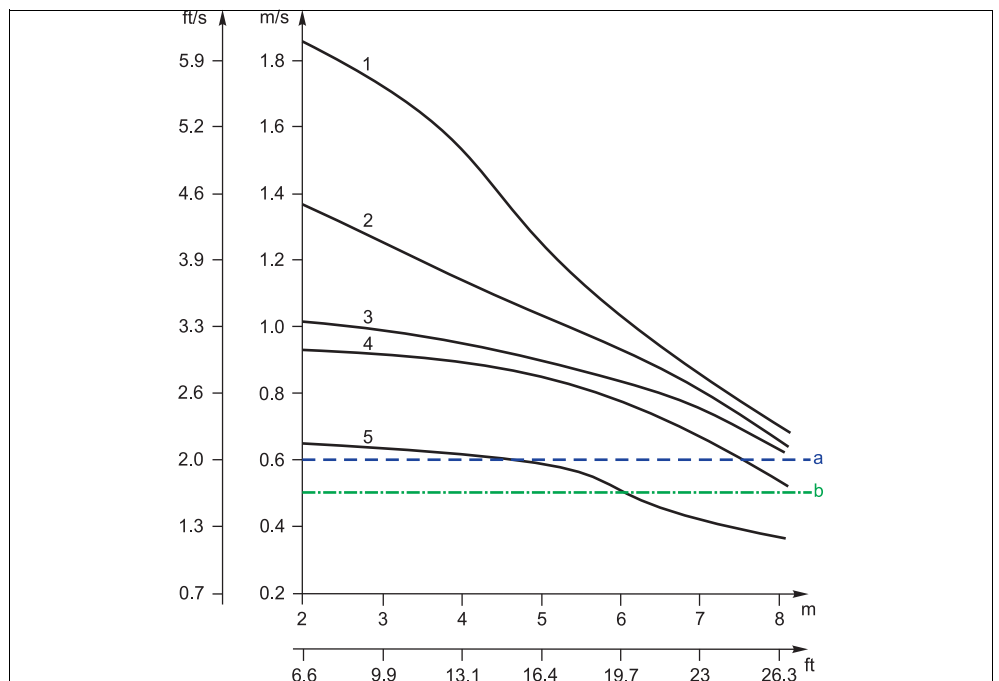

Intake speed in m/s with suction height in m

- a Intake speed as per Ö 5893 (Austrian standard); US EPA
- b Intake speed as per EN 25667, ISO 5667
- 1 ID 10 mm (3/8") vacuum pump
- 2 ID 13 mm (1/2") vacuum pump
- 3 ID 10 mm (3/8") peristaltic pump
- 4 ID 16 mm (5/8") vacuum pump
- 5 ID 19 mm (3/4") vacuum pump

Sample temperature regulation

The temperature of the sample compartment can be adjusted using the controller. The factory setting is 4 °C (39 °F). The current temperature is shown on the display and recorded in the internal data logger. A temperature sensor for measuring individual sample temperatures can also be ordered as an option.

The vaporizer and defrost heater are integrated in a special housing such that they are protected against corrosion and damage. The compressor and condenser are located in the upper section of the sampler. They can be easily accessed by removing the upper rear panel (for maintenance purposes).



Cooling system

a0013217

Equipment architecture

Slot and port assignment

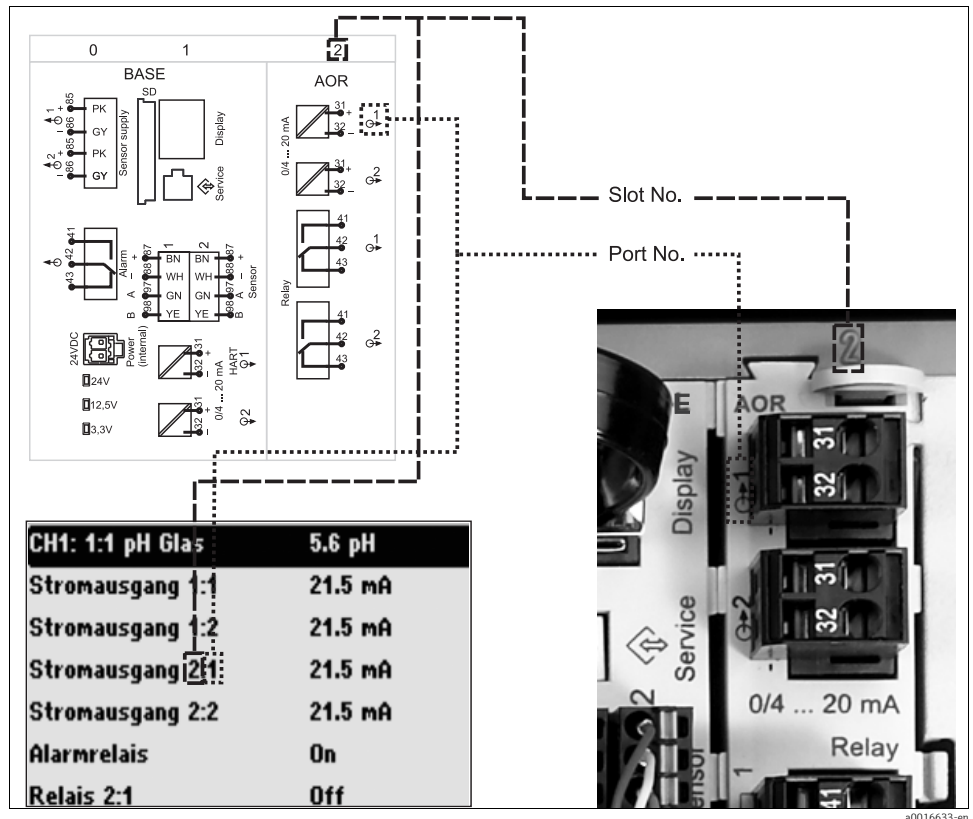

Slot and port assignment of hardware and how this information appears on the display

The electronic components are modular in design:

- There are several points available to connect electronic modules. These are known as "slots".
- The slots are numbered consecutively in the housing. Slots 0 and 1 are always reserved for the basic module.
- Each electronic module has one or more inputs and outputs or relays, collectively termed "ports" here.
- The ports are numbered consecutively for each electronic module and are automatically detected by the software.
- Outputs and relays are named according to their function, e.g. "current output", and are displayed with the slot and port numbers in ascending order.

Example:

– "Current output 2:1" means:

Slot 2 (e.g. AOR module) : Port 1 (current output 1 of AOR module)

- Inputs are assigned to measuring channels in ascending order, "Slot:Port number"

Example:

– "CH1: 1:1" means:

Slot 1 (basic module) : Port 1 (input 1) is channel 1 (CH1) and a conductivity sensor is connected to it



The unique terminal name is composed as follows:

Slot no. : Port no. : Terminal

Communication and data processing

Communication types:

- Fieldbuses
 - HART
 - PROFIBUS DP (Profile 3.02)
 - Modbus TCP or RS485
- Configuration via Ethernet

i Only one type of fieldbus communication can ever be active. The last activation code entered determines which bus is used.

Bus termination on the device

- Via slide switch at bus module 485
- Displayed via LED "T" on bus module 485

Dependability

Reliability

Memosens technology



Memosens makes your measuring point safer and more reliable:

- Non-contact, digital signal transmission enables optimum galvanic isolation
- No contact corrosion
- Completely watertight
- Laboratory sensor calibration possible, thus increasing measured value availability
- Predictive maintenance thanks to recording of sensor data, e.g.:
 - Total hours of operation
 - Hours of operation with very high or very low measured values
 - Hours of operation with high temperatures
 - Number of steam sterilizations
 - Sensor condition



a0013430

Sensor Check System (SCS)

The Sensor Check System (SCS) monitors the high impedance of the pH glass.

An alarm is triggered if a minimum impedance is not reached or if a maximum impedance is exceeded.

- The main cause of decreasing high-impedance is glass breakage.
- Causes of increasing impedance are:
 - dry sensor
 - worn out pH glass membrane.

Process Check System (PCS)

The PCS (Process Check System) tests the measuring signal for stagnation. If the measuring signal does not change over a certain period of time (several measured values), an alarm is triggered.

Main causes of stagnating measured values:

- Sensor is dirty or outside of medium
- Sensor is defective
- Process error (e.g. through control system)

Sensor Condition Check (SCC)

This function monitors the electrode status or the degree of wear and tear on the electrode. The status is conveyed via the messages "SCC electrode status bad" or "SCC electrode status satisfactory". The electrode status is updated following each calibration.

Maintainability

Modular design

The modular sampler design means it can be easily adapted to suit your needs:

- Retrofit add-on modules for new or extended range of functions, e.g. current outputs and relays
- Upgrade from one channel to multichannel measurement with digital sensors
- Upgrade to fieldbus communication (PROFIBUS DP, Modbus TCP, Modbus RS485, Ethernet for configuration)



E basic module for 2 sensors



Communication module

Memory

- Independent, integrated ring memories (FIFO) or stack memories for recording
 - an analog value (e.g. flow, pH value, conductivity)
 - events (e.g. power failure)
 - sample statistics (e.g. sample volume, filling times, bottle assignment)
- Program memory: max. 100 programs
- Data logbooks
 - Adjustable scan time: 1 to 3600 s (6 h)
 - max. 8 data logbooks
 - 150,000 entries per logbook
 - Graphic display (load curves) or numeric listing
- Calibration logbook: max. 75 entries
- Hardware logbook:
 - Hardware configuration and modifications
 - max. 125 entries
- Version logbook:
 - e.g. software updates
 - max. 50 entries
- Operation logbook: max. 250 entries
- Diagnostic logbook: max. 250 entries

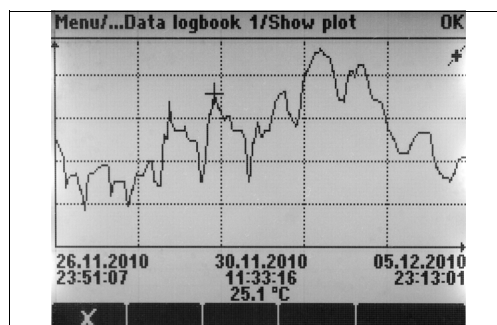

Data logbook: Graphic display

Mathematical functions (virtual process values)

In addition to "true" process values provided by connected physical sensors or analog inputs, you can have maximum 6 "virtual" process values calculated using mathematical functions.

The "virtual" process values can be:

- issued via a current output or fieldbus
- used as a control variable
- assigned as a measured variable to a limit contactor
- used as a measured variable to trigger cleaning
- displayed in user-defined measuring menus.

These mathematical functions are possible:

- pH calculation based on two conductivity values as per VGB 405 RL, e.g. in boiler feedwater
- Difference between two measured values from different sources, e.g. for membrane monitoring
- Differential conductivity, e.g. for monitoring the efficiency of ion exchangers
- Degassed conductivity, e.g. for process control systems in power plants
- Redundancy for monitoring two or three redundant measuring sensors
- rH calculation based on measured values of a pH sensor and an ORP sensor

FieldCare and Field Data Manager

Fieldcare

Software based on FDT/DTM technology for configuration and asset management

- Complete device configuration when connected via FXA291 and service interface
- Access to a number of configuration parameters and identification, measuring and diagnostic data when connected via HART modem
- Logbooks can be downloaded in CSV format or binary format for "Field Data Manager" software

Field Data Manager

Visualization software and database for measuring, calibration and configuration data

- SQL database which is protected against manipulation
- Functions to import, save and print out logbooks
- Load curves to display measured values

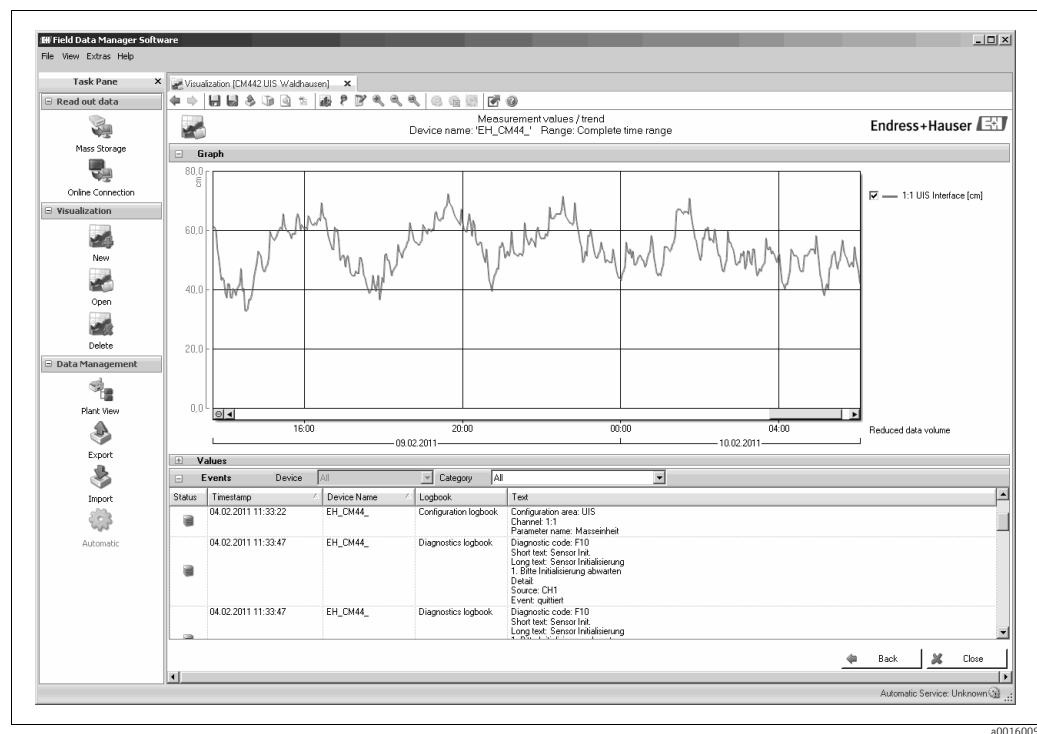

Field Data Manager: Load curves

SD card

The exchangeable storage medium enables:

- Quick and easy software updates and upgrades
- Data storage of internal device memory (e.g. logs)
- Transfer of complete configurations to a device with an identical setup (backup function)
- Transfer of configurations without the TAG and bus address to devices with an identical setup (copy function)

Endress+Hauser offers industry-approved SD cards as accessories. These memory cards provide maximum data security and integrity.

Other SD cards can also be used. However, Endress+Hauser does not accept any responsibility for the data security of such cards.

Safety**Real-time clock**

The device contains a real-time clock. In the event of a power failure, a button cell battery is used. This ensures that if the device is restarted, the date and time settings are retained and the time stamp for the logbooks is correct.

Data security

All settings, logbooks etc. are stored in a non-volatile memory to ensure that the data are retained even if there is a disruption to the power supply.

Input**Input types**

- 2 analog inputs
 - 2 binary inputs
 - 1 to 4 digital inputs for sensors with Memosens protocol (optional)
-

Measured variables

--> Documentation of the connected sensor

Temperature inputs**Measuring range**

-30 to 70 °C (-20 to 160 °F)

Input type

Pt1000

Accuracy

±0.5 K

Binary input, passive**Span**

12 to 30 V, galvanically isolated

Signal characteristics

Minimum pulse width: 100 ms

Analog input, passive/active**Span**

0/4 to 20 mA,
galvanically isolated

Accuracy

±0.5 % of measuring range

Output

Output signal

2 binary outputs (standard):
Open collector, max. 30 V, 200 mA

Depending on version (optional):

- 1 x 0/4 to 20 mA, active, HART communication, galvanically isolated from the sensor circuits and from one another
- 1 x 0/4 to 20 mA, active, galvanically isolated from the sensor circuits and from one another
- 2 x 0/4 to 20 mA, active, galvanically isolated from one another and from the sensor circuits
- 4 x 0/4 to 20 mA, active, galvanically isolated from the sensor circuits and from one another
- 6 x 0/4 to 20 mA, active, galvanically isolated from the sensor circuits and from one another

HART

Signal coding	FSK \pm 0.5 mA above current signal
Data transmission rate	1200 baud
Galvanic isolation	Yes
Load (communication resistance)	250 Ω

PROFIBUS DP

Signal coding	EIA/TIA-485, PROFIBUS-DP-compliant acc. to IEC 61158
Data transmission rate	9.6 kBd, 19.2 kBd, 93.75 kBd, 187.5 kBd, 500 kBd, 1.5 MBd, 6 MBd, 12 MBd
Galvanic isolation	Yes
Connectors	Spring-cage terminal (max. 1.5 mm), bridged internally in the connector (T function), M12 optional
Bus termination	Internal slide switch with LED display

Modbus RS485

Signal coding	EIA/TIA-485
Data transmission rate	2400, 4800, 9600, 19200, 38400, 57600 and 115200 baud
Galvanic isolation	Yes
Connectors	Spring-cage terminal (max. 1.5 mm), bridged internally in the connector (T function), M12 optional
Bus termination	Internal slide switch with LED display

Ethernet and Modbus TCP

Signal coding	IEEE 802.3 (Ethernet)
Data transmission rate	10 / 100 MBd
Galvanic isolation	Yes
Connection	RJ45, M12 optional
IP address	DHCP or configuration using menu

Signal on alarm

Adjustable, as per NAMUR Recommendation NE 43

- In measuring range 0 to 20 mA (HART is not available with this measuring range):
Error current from 0 to 23 mA
- In measuring range 4 to 20 mA:
Error current from 2.4 to 23 mA
- Factory setting for error current for both measuring ranges:
21.5 mA

LoadMax. 500 Ω **Linearization/transmission behavior**

Linear

Current outputs, active (optional)**Span**

0 to 23 mA

2.4 to 23 mA for HART communication

Signal characteristic

Linear

Electrical specification

Output voltage:

Max. 24 V

Cable specification

Recommended: shielded cable

Max. 2.5 mm² (14 AWG)

Relay outputs (optional)

Electrical specification of relay types**Relay types**

- 2 x changeover contact, coupled with binary output (optional)
- 1 single-pin changeover contact (alarm relay)

Relay switching capacity**Power unit (alarm relay)**

Switching voltage	Load (max.)	Switching cycles (min.)
230 V AC, $\cos\phi = 0.8$ to 1	0.1 A	700,000
	0.5 A	450,000
24 V DC, L/R = 0 to 1 ms	0.1 A	500,000
	0.5 A	350,000

Relay coupled with binary output

Switching voltage	Load (max.)	Switching cycles (min.)
230 V AC, $\cos\phi = 0.8$ to 1	5 A	100,000
24 V DC, L/R = 0 to 1 ms	5 A	100,000

Extension module

Switching voltage	Load (max.)	Switching cycles (min.)
230 V AC, $\cos\phi = 0.8$ to 1	0.1 A	700,000
	2 A	120,000
115 V AC, $\cos\phi = 0.8$ to 1	0.1 A	1,000,000
	2 A	170,000
24 V DC, L/R = 0 to 1 ms	0.1 A	500,000
	2 A	150,000

Minimum load (typical)

- Min. 100 mA with 5 V DC
- Min. 1 mA with 24 V DC
- Min. 5 mA with 24 V AC
- Min. 1 mA with 230 V AC

Protocol-specific data**HART**

Manufacturer ID	11 _h
Device type	119C _h (CM44x), 119D _h (CSFxx)
Device revision	001 _h
HART version	7.2
Device description files (DD/DTM)	www.endress.com Device Integration Manager (DIM)
Device variables	Dynamic variables PV, SV, TV, QV, 16 of which can be configured by the user and 16 of which are pre-defined
Supported features	PDM DD, AMS DD, DTM, FieldXpert DD

PROFIBUS-DP

Manufacturer ID	11 _h
Device type	155D _h (CM44x), 155C _h (CSFxx)
Profile version	3.02
GSD files	www.products.endress.com/profibus Device Integration Manager DIM
Output variables	16 AI blocks, 8 DI blocks
Input variables	8 AO blocks, 4 DO blocks
Supported features	<ul style="list-style-type: none"> ▪ 1 MSCY0 connection (cyclical communication, master class 1 to slave) ▪ 1 MSAC1 connection (acyclical communication, master class 1 to slave) ▪ 2 MSAC2 connections (acyclical communication, master class 2 to slave) ▪ Device lock: The device can be locked using the hardware or software. ▪ Addressing using DIL switches or software ▪ GSD, PDM DD, DTM

Modbus RS485

Protocol	RTU / ASCII
Function codes	03, 04, 06, 08, 16, 23
Broadcast support for function codes	06, 16, 23
Output data	16 measured values (value, unit, status), 8 digital values (value, status)
Input data	4 set points (value, unit, status), 4 digital values (value, status), diagnostic information
Supported features	Address can be configured using switch or software

Modbus TCP

TCP port	502
TCP connections	3
Protocol	RTU
Function codes	03, 04, 06, 08, 16, 23
Broadcast support for function codes	06, 16, 23
Output data	16 measured values (value, unit, status), 8 digital values (value, status)
Input data	4 set points (value, unit, status), 6 digital values (value, status), diagnostic information
Supported features	Address can be configured using DHCP or software

Web server

The web server allows complete access to the device configuration, measured values, diagnostic measurements, logbooks and service data via standard WiFi/WLAN/LAN/GSM or 3G router with a user-defined IP address.

TCP port	80
Supported features	<ul style="list-style-type: none"> ▪ Remote-controlled device configuration ▪ Save/restore device configuration ▪ Logbook export (file formats: CSV, FDM) ▪ Access to web server via DTM or Internet Explorer

Power supply

Electrical connection

--> For a detailed wiring diagram, see the Operating Instructions for Liquistation CSF34

Supply voltage

Depending on version:

- 100 to 120/200 to 240 V AC $\pm 10\%$, 50/60 Hz

NOTICE

The device does not have a power switch

- ▶ A fuse with a maximum rating of 10 A must be provided by the customer. Observe the local regulations for installation.

Cable entry

Depending on version:

- 1 x M25, 7 x M20 cable gland
- 1 x M25, 1 x M20 cable gland

Permitted cable diameter:

- M20x1.5 mm: 7 to 13 mm (0.28 to 0.51")
- M25x1.5 mm: 9 to 17 mm (0.20 to 0.67")

Mains fuse	Optional fuses on DIN rail <ul style="list-style-type: none"> ▪ T10A (for 24V power supply) ▪ T3.15A (for 230V power supply) ▪ T10A (fuse for battery backup)
Power consumption	<ul style="list-style-type: none"> ▪ Version with vacuum pump: 290 VA ▪ Version with peristaltic pump: 290 VA
Power failure	<ul style="list-style-type: none"> ▪ Power supply via battery (optional): 2 x 12 V, 7.2 Ah, with additional charge controller <ul style="list-style-type: none">  Replace batteries with battery type Panasonic LC-R127R2PG1. ▪ Real-time clock: lithium battery, type CR2032

Performance characteristics

Sampling methods	<p>Vacuum pump / peristaltic pump:</p> <ul style="list-style-type: none"> ▪ Event sampling ▪ Single and multiple samples ▪ Sampling table <p>Vacuum pump:</p> <ul style="list-style-type: none"> ▪ In proportion to time ▪ In proportion to volume <p>Peristaltic pump:</p> <ul style="list-style-type: none"> ▪ In proportion to time ▪ In proportion to volume ▪ In proportion to flow
Dosing volume	<ul style="list-style-type: none"> ▪ Vacuum pump: 20 to 350 ml (0.7 to 12 fl.oz.) ▪ Peristaltic pump: 10 to 10,000 ml (0.3 to 340 fl.oz.) <p> A sample volume < 20 ml can vary in dosing accuracy and repeatability, depending on the application.</p>
Dosing accuracy	<ul style="list-style-type: none"> ▪ Vacuum pump: ±5 ml (0.17 fl.oz.) or 5 % of the set volume ▪ Peristaltic pump: ±5 ml (0.17 fl.oz.) or 5 % of the set volume
Repeatability	<ul style="list-style-type: none"> ▪ Vacuum pump: 5 % ▪ Peristaltic pump: 5 %
Intake speed	<p>> 0.5 m/s (> 1.6 ft/s) for ≤ 13 mm (1/2") ID, in accordance with EN 25667, ISO 5667</p> <p>> 0.6 m/s (> 1.9 ft/s) for 10 mm (3/8") ID, in accordance with Ö 5893 (Austrian standard); US EPA</p>
Suction height	Max. 8 m (26 ft)
Hose length	Max. 30 m (98 ft)

Temperature control**Temperature sensors:**

- Sampling chamber temperature
- Sample temperature (optional)
- Outside temperature (optional)

Temperature regulator:

- Sample temperature range: 2 to 20 °C (36 to 68 °F)
 - Factory setting: 4 °C (39 °F)
- Automatic defrost system
- Cooling speed in accordance with Ö 5893 (Austrian standard):
 - 4 liters of water at 20 °C are cooled to 4 °C in less than 210 minutes
- Temperature stability of the sample at 4 °C for the ambient temperature range of -15 to 40 °C (5 to 105 °F)

Installation

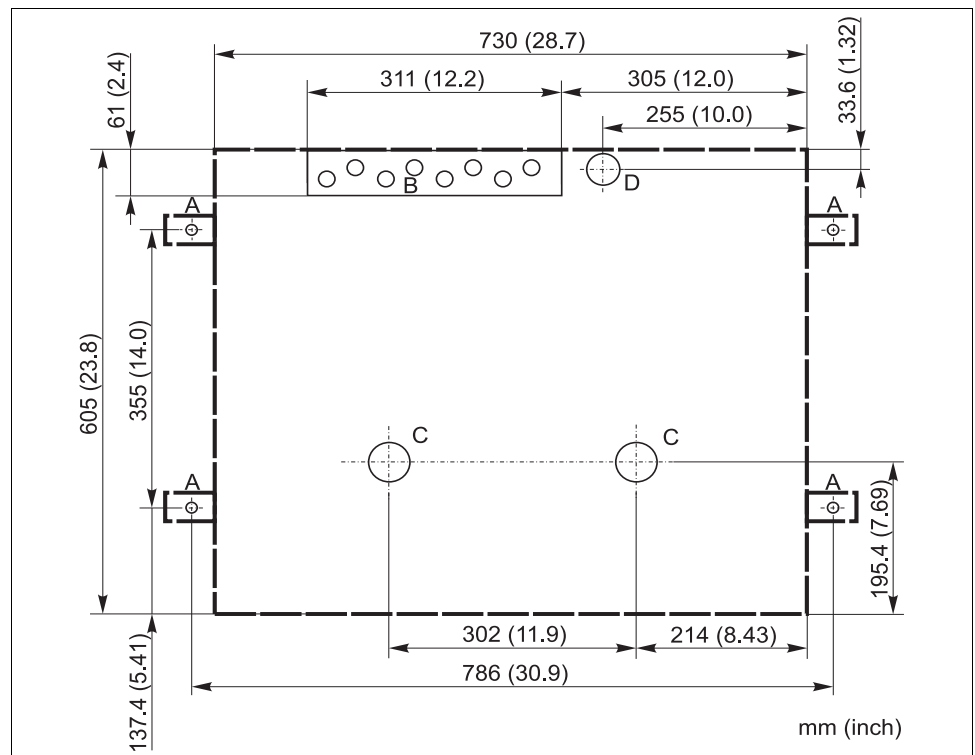
Installation instructions**Foundation plan**

a0012761

Foundation plan

- A Fasteners (4 x M10)
- B Cable inlet
- C Outlet for condensate and overflow > DN 50
- D Sample supply from below > DN 80
- - - Liquistation dimensions

Mounting conditions for Liquistation CSF34

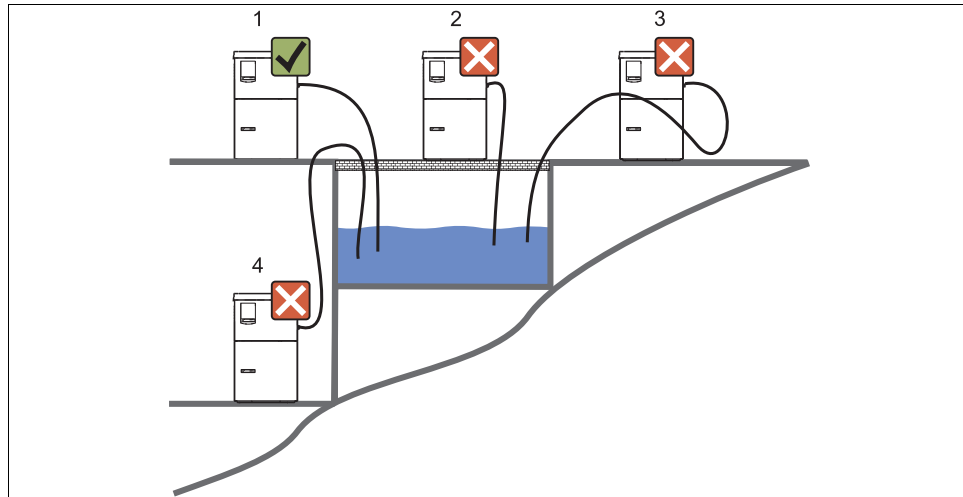

a0011693

Mounting conditions for Liquistation CSF34 for open channels

1. **Correct**
The suction line must be routed with a downward gradient to the sampling point.
2. **Incorrect**
The sampler should never be mounted in a place where it is exposed to aggressive gases.
3. **Incorrect**
Avoid siphoning effects in the suction line.
4. **Incorrect**
The suction pipe should never be routed with an upward gradient to the sampling point.

Note the following when erecting the device:

- Erect the device on a level surface.
- Protect the device against additional heating (e.g. from heaters).
- Protect the device against mechanical vibrations.
- Protect the device against strong magnetic fields.
- Make sure air can circulate freely at the side panels of the cabinet. Do not mount the device directly against a wall. Allow at least 150 mm (5.9") from the wall to the left and right.
- Do not mount the device directly above the inlet channel of a wastewater treatment plant.

Environment

Ambient temperature range	-30 to 50 °C (-20 to 120 °F)
Storage temperature	-20 to 60 °C (0 to 140 °F)
Degree of protection	Controller: NEMA TYPE 4X
Electromagnetic compatibility	Interference emission and interference immunity as per EN 61326-1: 2006, class A for industry
Electrical safety	In accordance with EN 61010-1, protection class I, environment ≤ 2000 m (6500 ft) above MSL. The device is designed for contamination level 2.
Relative humidity	10 to 95%, not condensing

Process

Medium temperature range 2 to 50 °C (36 to 122 °F)

Medium properties

Liquistation with vacuum pump

Capacitance level measurement used for:

- Media that tend to create a lot of foam or contain fats and grease
- Media with a conductivity < 30 µS/cm

Liquistation with peristaltic pump

- Sample media have to be free of abrasive substances.

Caution!

Pay attention to the material resistance of the wetted parts.

Process pressure (absolut)

Vacuum pump / peristaltic pump:

- unpressurized, open channel (unpressurized sampling)
- max. 1.8 bar piping (only with shutoff / inlet valve)

Process connection

- Vacuum pump:
 - Intake hose ID 10 mm (3/8"), 13 mm (1/2"), 16 mm (5/8") or 19 mm (3/4")
- Peristaltic pump:
 - Intake hose ID 10 mm (3/8")

Mechanical construction

Dimensions

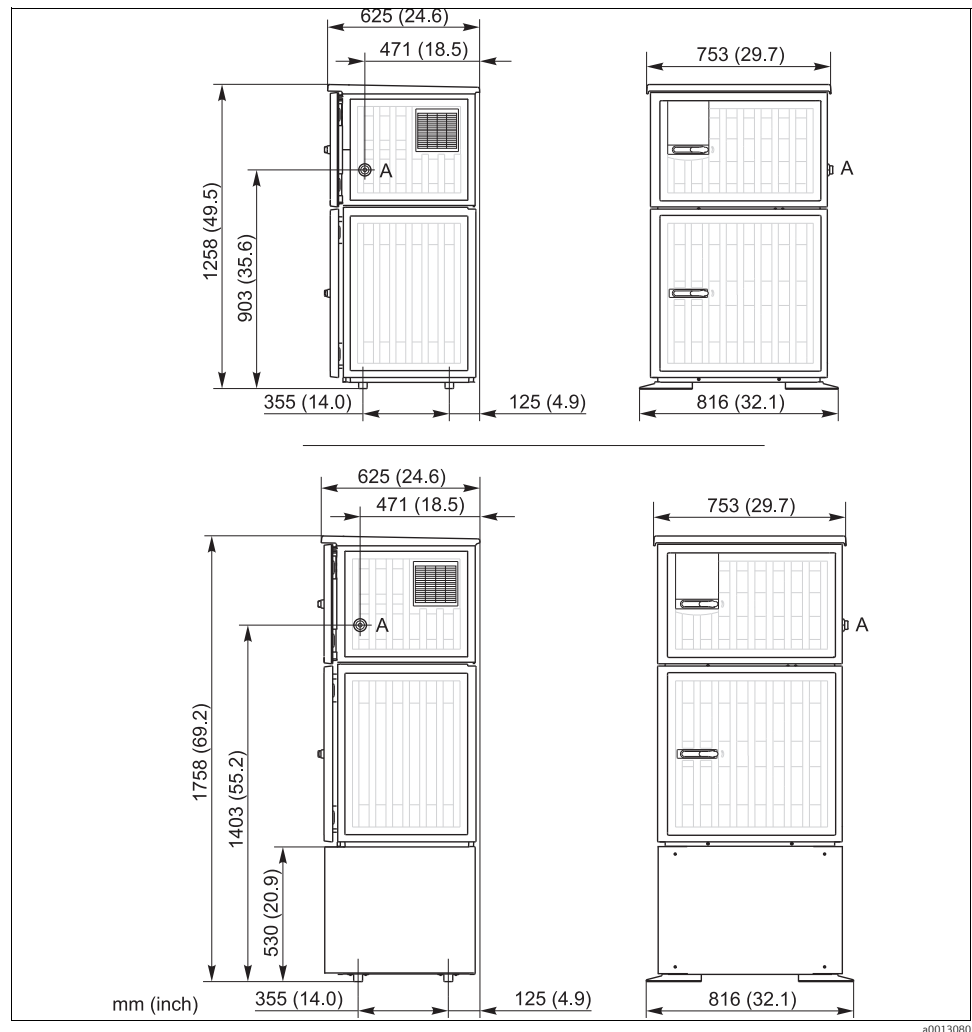

Dimensions of Liquistation CSF34 without/with stand

A Suction line connection

Weight 101 kg (223 lbs)

Material

Non-wetted parts	
Cabinet housing	Plastic ASA+PC V0 For standard applications in wastewater treatment plants, environmental monitoring and industrial wastewater treatment plants with an aggressive atmosphere.
Sample compartment inner dish	Plastic PP
Window	Safety glass, coated (optional)
Insulation	Plastic EPS "Neopor®"

Wetted parts	Vacuum pump	Peristaltic pump
Dosing tube	Plastic PP	-
Dosing chamber cover	Plastic PP	-
Conductivity sensors	Stainless steel V4A (1.4404)	-
Capacitance sensor	PSU	-
Dosing chamber	PMMA, glass (depending on version)	-
Dosing system outflow hose	Silicone	-
Pump tubing	-	Silicone
Distribution arm	Plastic PP	
Distribution arm cover	Plastic PE	
Composite container/bottles	Plastic PE, glass (depending on version)	
Suction line	Plastic PP	

Operability

Operating concept

The simple and structured operating concept sets new standards:

- Intuitive operation with the navigator and soft keys
- Fast configuration of application-specific measurement options
- Easy configuration and diagnosis thanks to plain-text display
- All languages that can be ordered are available in every device

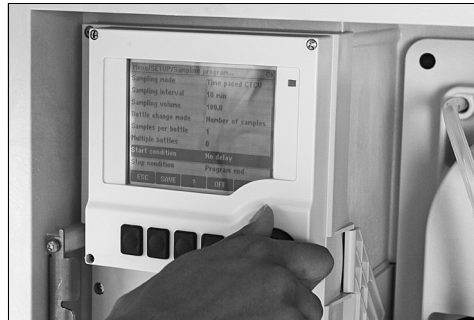

Easy operation

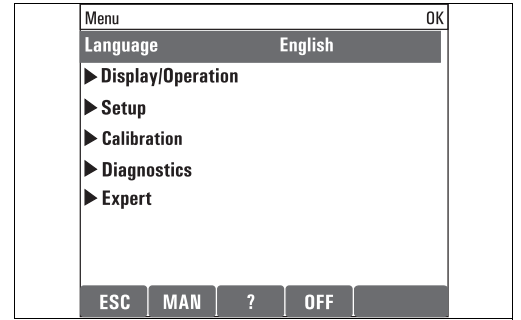

Plain-text menu

Display

Graphic display:

- Backlight with switch-off function
- Red display background for alarms alerts users to errors
- Transflective display technology for maximum contrast even in bright environments
- User-definable measuring menus mean you can always keep track of the values that are important for your application.

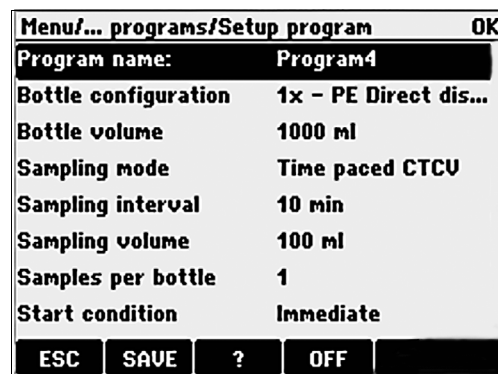

Example of program setup

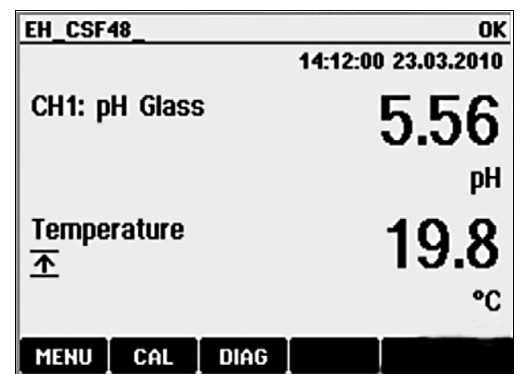

Example of measuring menus

Local operation

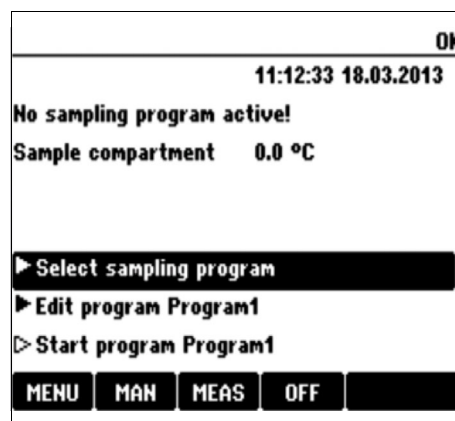

a0013322

- Liquid crystal display, backlighting
- 160 x 240 pixels
- 4 operating keys (soft key function) and navigator
- Menu-guided operation

Remote operation

Via HART (e.g. via HART modem and FieldCare)

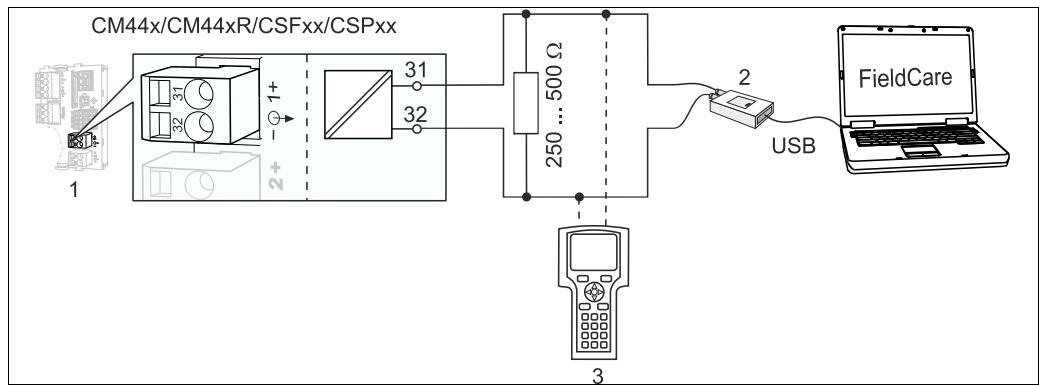

a0015608

HART via modem

- 1 Base L or E device module: Current output 1 with HART
- 2 HART modem for connection to PC, e.g. Commubox FXA191 (RS232) or FXA195¹⁾ (USB)
- 3 HART handheld terminal

Via PROFIBUS DP

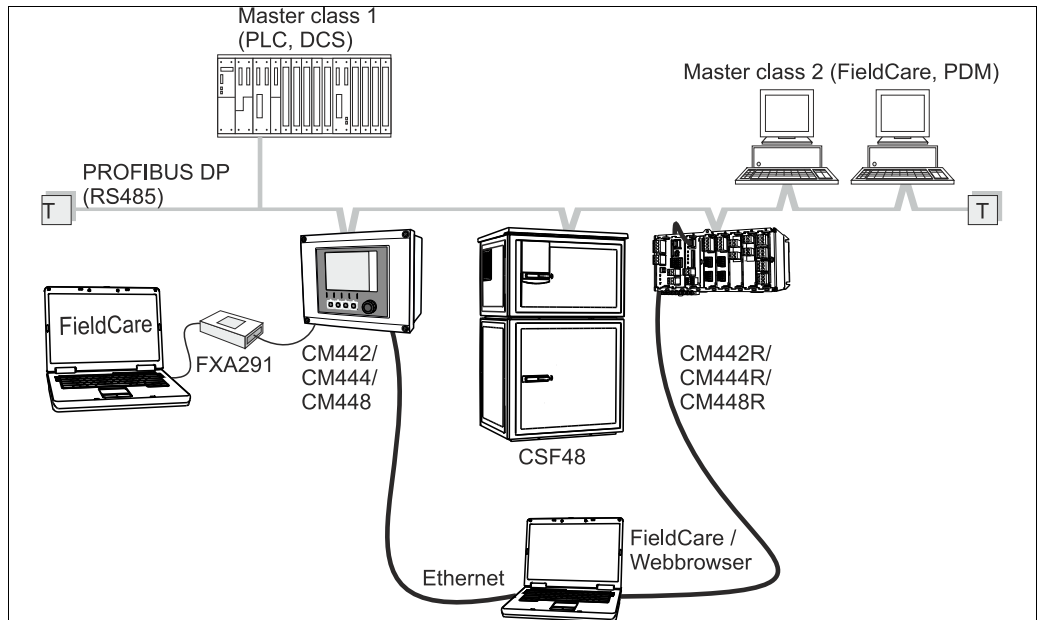

a0015874

PROFIBUS DP

- T Terminating resistor

1) Switch position "on" (replaces resistance)

Via Modbus RS485

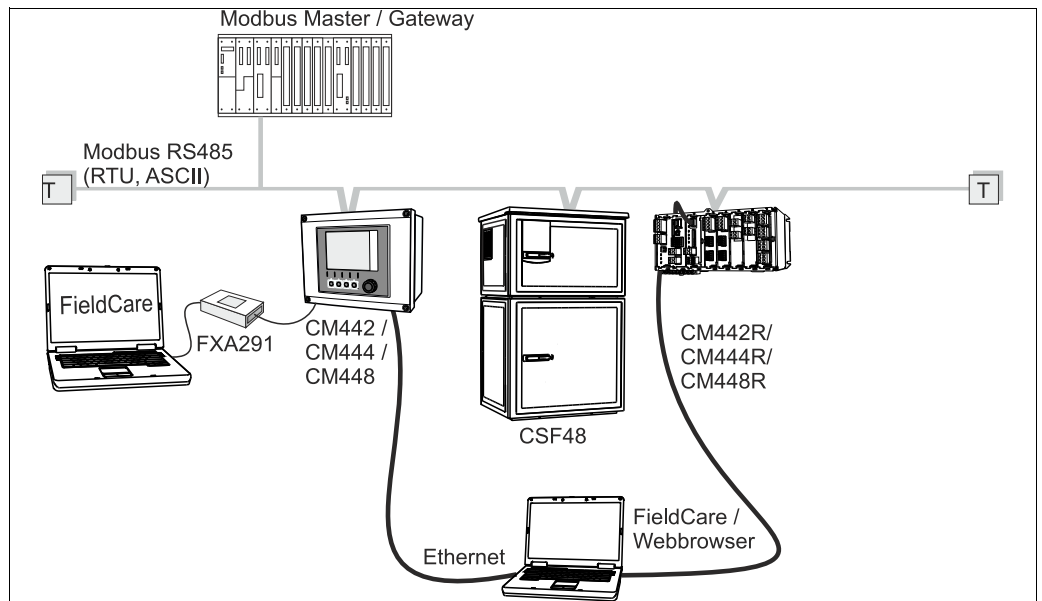

a0015875

Modbus RS485

T Terminating resistor

Via Ethernet/web server/Modbus TCP

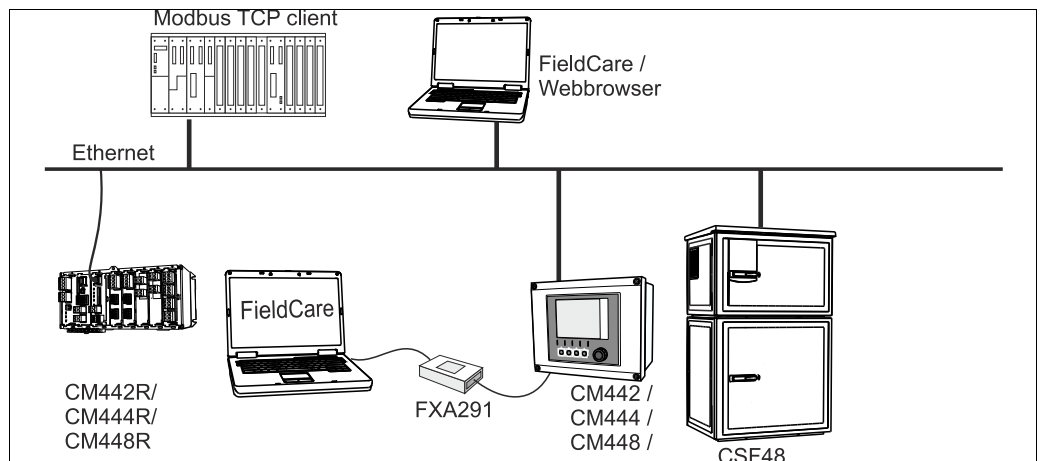

a0015876

Modbus TCP and / or Ethernet

Communication

- 1 service interface
- Optionally on front panel
- Commubox FXA291 (accessory) required for communication with the PC

Software

Field Data Manager

- Standardized user interface under Windows®
- Reading out the internal memory containing the measured flow rate, sample volume taken etc.

FieldCare

- Device settings saved in a database
- Configuration

Ordering information

Product structure

You can create a valid and complete order code online using the Configurator.

Enter the following URLs in your browser to access the relevant product page:
www.products.endress.com/csf34

1. You can choose from the following options on the right of the product page:

Product page function
:: Add to product list
:: Price & order information
:: Compare this product
:: Configure this product

2. Click "Configure this product".
3. The Configurator opens in a separate window. You can now configure your device and you will receive the complete order code valid for that device.
4. Now export the order code as a PDF file or Excel file. To do so, click the appropriate button at the top of the page.

Scope of delivery

The scope of delivery comprises:

- 1 Liquistation CSF34 with:
 - The ordered bottle configuration
 - Optional hardware
- Accessories kit
 - For peristaltic or vacuum pump:
 - Connection nipple for suction line with various angles (straight, 90°), Allen key (for version with vacuum pump only)
- 1 "Commissioning" Operating Instructions
 (In the preferred language if the "Default operating language" order option is selected. Otherwise, the Brief Operating Instructions supplied are in English)
- 1 CD-ROM with Operating Instructions in all available languages, an application handbook and simulation software
- Optional accessories

Certificates and approvals

Approvals for power supply

The power supply is approved by:

- CSA ("C" and "US")
- UL (UL 60950-1) ("C" and "US")
- UL (UL 508)

Accessories

i The most important accessories that could be delivered at the time this document went to print are listed below.

For accessories not listed here, please contact your service department or sales center.

Accessories for Liquistation CSF34

Order no.	Bottle tray + bottles + cover
71162811	Bottle tray + 2 x 3.8 liter (1.00 US gal.) glass + cover
71111155	Bottle tray + 12 x 2 liter (0.53 US gal.) PE angular bottle + cover
71111156	Bottle tray + 24 x 1 liter (0.26 US gal.) PE angular bottle + cover
71111157	Bottle tray + 12 x 1 liter (0.26 US gal.) + 6 x 2 liter (0.53 US gal.) PE angular bottle + cover
Distribution plate; locating insert	
71111163	Locating insert for bottle tray with angular bottles
Bottles + covers	
71162812	3.8 liter (1.00 US gal.) glass + cover, 1 pc.
71111169	13 liter (3.43 US gal.) PE + cover, 1 pc.
71111170	25 liter (5.28 US gal.) PE + cover, 1 pc.
71111172	30 liter (7.92 US gal.) PE + cover, 1 pc.
71111173	60 liter (15.8 US gal.) PE + cover, 1 pc.
71111176	1 liter (0.26 US gal.) PE angular bottle + cover, 24 pcs.
71111178	2 liter (0.53 US gal.) PE angular bottle + cover, 12 pcs.
Complete suction line	
71111233	Suction line ID 10 mm (3/8"), PVC clear, reinforced fabric, length 10 m (33 ft), suction head V4A
71111234	Suction line ID 10 mm (3/8"), EPDM black, length 10 m (33 ft), suction head V4A
71111235	Suction line ID 13 mm (1/2"), PVC green, reinforced spiral wire, length 10 m (33 ft), suction head V4A
71111236	Suction line ID 13 mm (1/2"), EPDM black, length 10 m (33 ft), suction head V4A
71111237	Suction line ID 16 mm (5/8"), PVC green, reinforced spiral wire, length 10 m (33 ft), suction head V4A
71111238	Suction line ID 16 mm (5/8"), EPDM black, length 10 m (33 ft), suction head V4A
71111239	Suction line ID 19 mm (3/4"), PVC green, reinforced spiral wire, length 10 m (33 ft), suction head V4A
71111240	Suction line ID 19 mm (3/4"), EPDM black, length 10 m (33 ft), suction head V4A
Suction line coil	
71111482	... m, suction line ID 10 mm (3/8"), PVC clear
71111484	... m, suction line ID 10 mm (3/8"), EPDM black
71111485	... m, suction line ID 13 mm (1/2"), PVC green
71111486	... m, suction line ID 13 mm (1/2"), EPDM black
71111487	... m, suction line ID 16 mm (5/8"), PVC green
71111481	... m, suction line ID 16 mm (5/8"), EPDM black
71111488	... m, suction line ID 19 mm (3/4"), PVC green
71111489	... m, suction line ID 19 mm (3/4"), EPDM black
71111490	... m, suction line ID 32 mm (1 1/4"), PVC green
Suction head	
71111184	Suction head V4A for ID 10 mm (3/8"), 1 pc.
71111185	Suction head V4A for ID 13 mm (1/2"), 1 pc.
71111186	Suction head V4A for ID 16 mm (5/8"), 1 pc.
71111187	Suction head V4A for ID 19 mm (3/4"), 1 pc.
Terminated hose; vacuum pump	
71111188	Dosing hose to distributor, 2 pcs, material: silicon
71111189	Dosing hose to distributor, 25 pcs, material: silicon
Terminated hose; peristaltic pump	
71111191	Pump tubing, 2 pcs; material: silicon
71111192	Pump tubing, 25 pcs; material: silicon
Communication; software	
71110815	SD card, 1 GB, Industrial Flash Drive
51516983	Commubox FXA291 + FieldCare Device Setup
71129799	Field Data Manager software; 1 license, analysis report
71127100	SD card with Liquiline firmware, 1 GB, industrial flash drive
71128428	Activation code for digital HART communication
71135635	Activation code for PROFIBUS DP
71135636	Activation code for Modbus RS485
71135637	Activation code for Modbus TCP

Accessories for parameter measurements

Sensors**Glass electrodes**

Orbisint CPS11D

- pH sensor with Memosens technology
- Dirt-repellent PTFE diaphragm
- Order as per product structure (--> Online Configurator, www.products.endress.com/cps11d)
- Technical Information TI028C/07/EN

Ceraliquid CPS41D

- pH sensor with Memosens technology
- Ceramic diaphragm and KCl liquid electrolyte
- Order as per product structure (--> Online Configurator, www.products.endress.com/cps41d)
- Technical Information TI079C/07/EN

Ceragel CPS71D

- pH sensor with Memosens technology
- Double-chamber reference system and integrated bridge electrolyte
- Order as per product structure (--> Online Configurator, www.products.endress.com/cps71d)
- Technical Information TI245C/07/EN

Orbipore CPS91D

- pH sensor with Memosens technology
- Open aperture diaphragm for media with high dirt load
- Order as per product structure (--> Online Configurator, www.products.endress.com/cps91d)
- Technical Information TI375C/07/EN

Memosens CPS16D

- Combined pH/ORP sensor for process technology, with dirt-repellent PTFE diaphragm
- With Memosens technology
- Order as per product structure (--> Online Configurator, www.products.endress.com/cps16d)
- Technical Information TI00503C/07/EN

Memosens CPS76D

- Combined pH/ORP sensor for process technology, hygiene and sterile applications
- With Memosens technology
- Order as per product structure (--> Online Configurator, www.products.endress.com/cps76d)
- Technical Information TI00506C/07/EN

Memosens CPS96D

- Combined pH/ORP sensor for chemical processes
- With poison-resistant reference with ion trap
- With Memosens technology
- Order as per product structure (--> Online Configurator, www.products.endress.com/cps96d)
- Technical Information TI00507C/07/EN

Orbipac CPF81D

- Compact pH sensor for installation or immersion operation in process water and wastewater
- Order as per product structure (--> Online Configurator, www.products.endress.com/cpf81d)
- Technical Information TI191C/07/EN

Pfaunder electrodes

Ceramax CPS341D

- pH electrode with pH-sensitive enamel
- Meets toughest requirements for accuracy, pressure, temperature, sterility and durability
- Order as per product structure (--> Online Configurator, www.products.endress.com/cps341d)
- Technical Information TI468C/07/EN

ORP sensors

Orbisint CPS12D

- ORP sensor with Memosens technology
- Dirt-repellent PTFE diaphragm;
- Order as per product structure (--> Online Configurator, www.products.endress.com/cps12d)
- Technical Information TI367C/07/EN

Ceraliquid CPS42D

- ORP sensor with Memosens technology
- Ceramic diaphragm and KCl liquid electrolyte
- Order as per product structure (--> Online Configurator, www.products.endress.com/cps42d)
- Technical Information TI373C/07/EN

Ceragel CPS72D

- ORP sensor with Memosens technology
- Double-chamber reference system and integrated bridge electrolyte;
- Order as per product structure (--> Online Configurator, www.products.endress.com/cps72d)
- Technical Information TI374C/07/EN

Orbipac CPF82D

- Compact pH sensor for flow or immersion operation in process water and wastewater
- Order as per product structure (--> Online Configurator, www.products.endress.com/cpf82d)
- Technical Information TI191C/07/EN

Orbipore CPS92D

- ORP sensor with Memosens technology
- Open aperture diaphragm for media with high dirt load
- Order as per product structure (--> Online Configurator, www.products.endress.com/cps92d)
- Technical Information TI435C/07/EN

pH ISFET sensors**Tophit CPS471D**

- Sterilizable and autoclavable ISFET sensor with Memosens technology
- For the food and pharmaceutical industries, process engineering, water treatment and biotechnology
- Order as per product structure (--> Online Configurator, www.products.endress.com/cps471d)
- Technical Information TI283C/07/EN

Tophit CPS441D

- Sterilizable ISFET sensor with Memosens technology
- For media with low conductivity, with liquid KCl electrolyte
- Order as per product structure (--> Online Configurator, www.products.endress.com/cps441d)
- Technical Information TI352C/07/EN

Tophit CPS491D

- ISFET sensor with Memosens technology
- Open aperture diaphragm for media with high dirt load
- Order as per product structure (--> Online Configurator, www.products.endress.com/cps491d)
- Technical Information TI377C/07/EN

Inductively measuring conductivity sensors**Indumax CLS50D**

- High-stability inductive conductivity sensor for standard, Ex and high-temperature applications
- Memosens protocol
- Order as per product structure (--> Online Configurator, www.products.endress.com/cls50d)
- Technical Information TI182C/07/EN

Conductively measuring conductivity sensors**Condumax CLS15D**

- Conductive conductivity sensor for pure and ultra-pure water and Ex applications
- Order as per product structure (--> Online Configurator, www.products.endress.com/cls15d)
- Technical Information TI109C/07/EN

Condumax CLS16D

- Hygienic, conductive conductivity sensor for pure and ultra-pure water and Ex applications
- With EHEDG and 3A approval
- Order as per product structure (--> Online Configurator, www.products.endress.com/cls16d)
- Technical Information TI227C/07/EN

Condumax CLS21D

- Two-electrode sensor in plug-in head and fixed cable version
- Order as per product structure (--> Online Configurator, www.products.endress.com/cls21d)
- Technical Information TI085C/07/EN

Oxygen sensors

Oxymax COS51D

- Amperometric sensor for dissolved oxygen, with Memosens technology
- Order as per product structure (--> Online Configurator, www.products.endress.com/cos51d)
- Technical Information TI413C/07/EN

Oxymax COS61D

- Optical oxygen sensor for drinking water and industrial water measurement
- Measuring principle: quenching
- Memosens protocol
- Material: stainless steel 1.4571 (AISI 316Ti)
- Order as per product structure (--> Online Configurator, www.products.endress.com/cos61d)
- Technical Information TI387C/07/EN

Oxymax COS22D

- Sterilizable sensor for dissolved oxygen
- Order as per product structure (--> Online Configurator, www.products.endress.com/cos22d)
- Technical Information TI446C/07/EN

Chlorine sensors

CCS142D

- Membrane-covered amperometric sensor for free chlorine
- Memosens technology
- Measuring range 0.01 to 20 mg/l
- Order as per product structure (--> Online Configurator, www.products.endress.com/ccs142d)
- Technical Information TI419C/07/EN

Ion-selective sensors

ISEmax CAS40D

- Ion-selective sensors
- Order as per product structure (--> Online Configurator, www.products.endress.com/cas40d)
- Technical Information TI491C/07/EN

Turbidity sensors

Turbimax CUS51D

- For nephelometric measurement of turbidity and solids in wastewater
- 4-beam scattered light method
- With Memosens protocol
- Order as per product structure (--> Online Configurator, www.products.endress.com/cus51d)
- Technical Information TI461C/07/EN

SAC and nitrate sensors

Viomax CAS51D

- SAC and nitrate measurement in drinking water and wastewater
- With Memosens protocol
- Order as per product structure (--> Online Configurator, www.products.endress.com/cas51d)
- Technical Information TI459C/07/EN

Interface measurement

Turbimax CUS71D

- Immersion sensor for interface measurement
- Ultrasonic interface sensor
- Order as per product structure (--> Online Configurator, www.products.endress.com/cus71d)
- Technical Information TI490C/07/EN

Measuring cable

Memosens data cable

CYK10

- For digital sensors with Memosens technology
pH, ORP, oxygen (amperometric), chlorine, conductivity (conductive)
- Order as per product structure (--> Online Configurator, www.products.endress.com/cyk10)

Measuring cable CYK81

- Unterminated cable for extending the sensor cables (e.g. Memosens)
- 2 x 2 wires, twisted with shield and PVC sheath (2 x 2 x 0.5 mm² + shield)
- Goods sold by meter, Order no.: 51502543

www.addresses.endress.com
