

Operating Instructions

Proline Promag P 10

Electromagnetic flowmeter
IO-Link

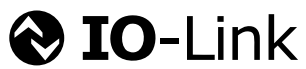

Table of contents

1	About this document	6	8	Commissioning	62
	Document function	6		Post-installation check and post-connection check	62
	Related documentation	6		IT security	62
	Symbols	7		Device-specific IT security	62
	Registered trademarks	9		Switching on the device	63
2	Safety instructions	12		Commissioning the device	64
	Requirements for specialist personnel	12		Backing up or duplicating the device data	64
	Requirements for operating personnel	12	9	Operation	66
	Incoming acceptance and transport	12		Operational display	66
	Adhesive labels, tags and engravings	12		Reading off the device locking status	66
	Environment and process	12		HistoROM data management	67
	Workplace safety	12	10	Diagnostics and troubleshooting	70
	Installation	12		General troubleshooting	70
	Electrical connection	12		Diagnostic information via LED	71
	Surface temperature	13		Diagnostic information on local display	73
	Commissioning	13		Diagnostic information in FieldCare or DeviceCare	74
	Modifications to the device	13		Changing the diagnostic information	75
3	Product information	16		Overview of diagnostic information	75
	Measuring principle	16		Pending diagnostic events	78
	Intended use	16		Diagnostic list	78
	Incoming acceptance	16		Event logbook	78
	Product identification	17		Resetting the device	80
	Transport	19	11	Maintenance	84
	Checking the storage conditions	21		Maintenance tasks	84
	Recycling of packaging materials	21		Services	84
	Product design	22	12	Disposal	86
	Firmware history	24		Removing the device	86
	Device history and compatibility	24		Disposing of the device	86
4	Installation procedure	26	13	Technical data	88
	Installation conditions	26		Input	88
	Device installation	33		Output	90
	Post-installation check	37		Power supply	92
5	Electrical connection	40		Cable specifications	93
	Connecting requirements	40		Performance characteristics	95
	Connecting cable connection	41		Environment	97
	Transmitter connection	46		Process	99
	Ensuring potential equalization	46		Mechanical construction	105
	Removing a cable	50		Local display	109
	Hardware settings	50		Certificates and approvals	110
	Post-connection check	51		Application packages	112
6	Operation	54	14	Dimensions in SI units	114
	Overview of the operating options	54		Compact version	114
	Operation via SmartBlue app	54		Remote version	117
7	System integration	58		Fixed flange	119
	Device description files	58		Lap joint flange	129
	Measured variables via HART protocol	58		Lap joint flange, stamped plate	132

Accessories	133
15 Dimensions in US units	136
Compact version	136
Remote version	139
Fixed flange	141
Lap joint flange	142
Accessories	143
16 Accessories	146
Device-specific accessories	146
Communication-specific accessories	147
Service-specific accessory	147
System components	148
17 Appendix	150
Screw tightening torques	151
Examples of electric terminals	158

Index

1 About this document

Document function	6
Related documentation	6
Symbols	7
Registered trademarks	9

Document function



These Operating Instructions provide all of the information that is required in various phases of the life cycle of the device:

- Incoming acceptance and product identification
- Storage and transport
- Installation and connection
- Commissioning and operation
- Diagnostics and troubleshooting
- Maintenance and disposal

Related documentation

Technical information	Overview of the device with the most important technical data.
Operating instructions	All the information that is required in the various phases of the life cycle of the device: from product identification, incoming acceptance and storage, to mounting, connection, operation and commissioning through to troubleshooting, maintenance and disposal as well as the technical data and dimensions.
Sensor Brief Operating Instructions	Incoming acceptance, transport, storage and mounting of the device.
Transmitter Brief Operating Instructions	Electrical connection and commissioning of the device.
Description of Parameters	Detailed explanation of the menus and parameters.
Safety Instructions	Documents for the use of the device in hazardous areas.
Special Documentation	Documents with more detailed information on specific topics.
Installation Instructions	Installation of spare parts and accessories.

The related documentation is available online:

Device Viewer	On the www.endress.com/deviceviewer website, enter the serial number of the device: nameplate → <i>Product identification</i> ,  17
Endress+Hauser Operations App	<ul style="list-style-type: none"> ▶ Scan the Data Matrix code: nameplate → <i>Product identification</i>,  17 ▶ Enter the serial number of the device: nameplate → <i>Product identification</i>,  17

Symbols

Warnings

DANGER

This symbol alerts you to an immediate dangerous situation. Failure to avoid the situation will result in a fatal or serious injury.

WARNING

This symbol alerts you to a potentially dangerous situation. Failure to avoid the situation may result in a fatal or serious injury.





CAUTION

This symbol alerts you to a potentially dangerous situation. Failure to avoid the situation may result in a minor or mild injury.





NOTICE

This symbol alerts you to a potentially harmful situation. Failure to avoid the situation may result in damage to the facility or to something in the facility's vicinity.



Electronics

-  Direct current
-  Alternating current
-  Direct current and alternating current
-  Terminal connection for potential equalization







Device communication







-  Communication via a wireless, local area network.
-  Bluetooth is enabled.
-  LED is off.
-  LED flashing.
-  LED lit.

Tools

-  Flat-blade screwdriver
-  Hexagon wrench
-  Wrench

Types of information

-  Preferred procedures, processes or actions
-  Permitted procedures, processes or actions
-  Forbidden procedures, processes or actions
-  Additional information
-  Reference to documentation
-  Reference to page
-  Reference to graphic

-  Measure or individual action to be observed
-  Series of steps
-  Result of an individual step
-  Help in the event of a problem
-  Visual inspection
-  Write-protected parameter

Registered trademarks

IO-Link®

Is a registered trademark. It may only be used in conjunction with products and services by members of the IO-Link Community or by non-members who hold an appropriate license. For more specific guidelines on use, refer to the IO-Link Community rules on: www.io-link.com.

Bluetooth®

The Bluetooth word mark and Bluetooth logos are registered trademarks of Bluetooth SIG. Inc. and any use of such marks by Endress+Hauser is under license. Other trademarks and trade names are those of their respective owners.

Apple®

Apple, the Apple logo, iPhone, and iPod touch are trademarks of Apple Inc., registered in the U.S. and other countries. App Store is a service mark of Apple Inc.

Android®

Android, Google Play and the Google Play logo are trademarks of Google Inc.

2 Safety instructions

Requirements for specialist personnel	12
Requirements for operating personnel	12
Incoming acceptance and transport	12
Adhesive labels, tags and engravings	12
Environment and process	12
Workplace safety	12
Installation	12
Electrical connection	12
Surface temperature	13
Commissioning	13
Modifications to the device	13

Requirements for specialist personnel

- ▶ Installation, electrical connection, commissioning, diagnostics and maintenance of the device must only be carried out by trained, specialist personnel authorized by the facility's owner-operator.
- ▶ Before commencing work, the trained, specialist personnel must carefully read, understand and adhere to the Operating Instructions, additional documentation and certificates.
- ▶ Comply with national regulations.

Requirements for operating personnel

- ▶ Operating personnel are authorized by the facility's owner-operator and are instructed according to the requirements of the task.
- ▶ Before commencing work, the operating personnel must carefully read, understand and adhere to the instructions provided in the Operating Instructions and additional documentation.

Incoming acceptance and transport

- ▶ Transport the device in a correct and appropriate manner.
- ▶ Do not remove protective covers or protective caps on the process connections.

Adhesive labels, tags and engravings

- ▶ Pay attention to all the safety instructions and symbols on the device.

Environment and process

- ▶ Only use the device for the measurement of appropriate media.
- ▶ Keep within the device-specific pressure range and temperature range.
- ▶ Protect the device from corrosion and the influence of environmental factors.

Workplace safety

- ▶ Wear the required protective equipment according to national regulations.
- ▶ Do not ground the welding unit via the device.
- ▶ Wear protective gloves if working on and with the device with wet hands.

Installation

- ▶ Do not remove protective covers or protective caps on the process connections until just before you install the sensor.
- ▶ Do not damage or remove the liner on the flange.
- ▶ Observe tightening torques.

Electrical connection

- ▶ Comply with national installation regulations and guidelines.
- ▶ Observe cable specifications and device specifications.
- ▶ Check the cable for damage.

- ▶ If using the device in hazardous areas, observe the "Safety Instructions" documentation.
- ▶ Provide (establish) potential equalization.
- ▶ Provide (establish) grounding.

Surface temperature

Media with elevated temperatures can cause the surfaces of the device to become hot. For this reason, note the following:

- ▶ Mount suitable touch protection.
- ▶ Wear suitable protective gloves.

Commissioning

- ▶ Install the device only if it is in proper technical condition, free from errors and faults.
- ▶ Only put the device into operation once you have performed the post-installation check and post-connection check.

Modifications to the device

Modifications or repairs are not permitted and can pose a danger. For this reason, note the following:

- ▶ Only carry out modifications or repairs after consulting beforehand with an Endress+Hauser service organization.
- ▶ Only use original spare parts and original accessories from Endress+Hauser.
- ▶ Install original spare parts and original accessories according to the Installation Instructions.

3 Product information

Measuring principle	16
Intended use	16
Incoming acceptance	16
Product identification	17
Transport	19
Checking the storage conditions	21
Recycling of packaging materials	21
Product design	22
Firmware history	24
Device history and compatibility	24

Measuring principle

Electromagnetic flow measurement on the basis of *Faraday's law of magnetic induction*.

Intended use

The device is only suitable for flow measurement of liquids with a minimum conductivity of 5 $\mu\text{S}/\text{cm}$.

Depending on the version ordered, the device measures poisonous and oxidizing media.

Devices for use in hygienic applications, or where there is an increased risk due to pressure, are labeled accordingly on the nameplate.

Non-designated use can compromise safety. The manufacturer is not liable for damage caused by improper or non-intended use.

Incoming acceptance

Is technical documentation provided with the device?	<input type="checkbox"/>
Does the scope of supply match the specifications on the delivery note?	<input type="checkbox"/>
Is the order code on the delivery note and nameplate identical?	<input type="checkbox"/>
Does the device bear any signs of damage from transportation?	<input type="checkbox"/>
Has an incorrect device been ordered or delivered or has the device been damaged in transit? Complaints or returns: https://www.endress.com/support/return-material	<input type="checkbox"/>

Product identification

Device tag

The device comprises the following parts:

- Proline 10 transmitter
- Promag P sensor

Transmitter nameplate

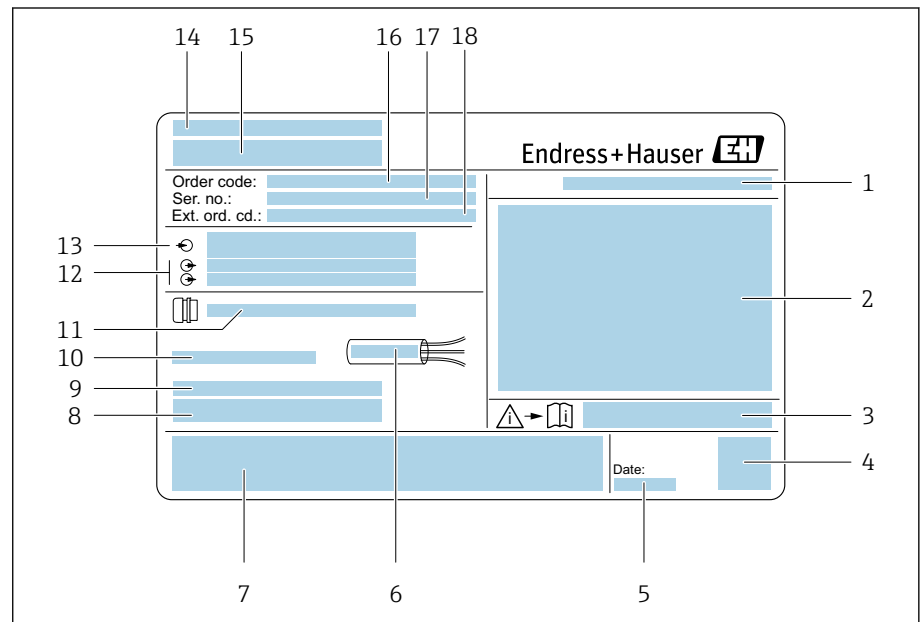

A0042943

1 Example of a transmitter nameplate

- 1 Degree of protection
- 2 Approvals for hazardous area, electrical connection data
- 3 Document number of safety-related supplementary documentation
- 4 Data Matrix code
- 5 Date of manufacture: year-month
- 6 Permitted temperature range for cable
- 7 CE mark and other approval marks
- 8 Firmware version (FW), Device ID
- 9 Additional information in the case of special products
- 10 Permitted ambient temperature (T_a)
- 11 Information on the cable entry
- 12 Available inputs and outputs: supply voltage
- 13 Electrical connection data: supply voltage and supply power
- 14 Place of manufacture
- 15 Transmitter name
- 16 Order code
- 17 Serial number
- 18 Extended order code

Sensor nameplate

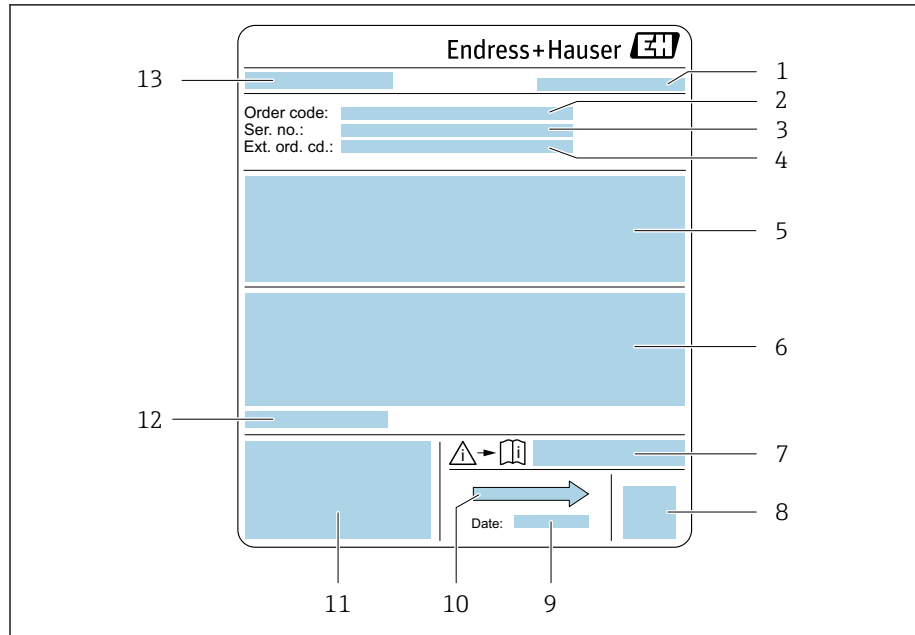

A0044140

 2 Example of sensor nameplate

- 1 Place of manufacture
- 2 Order code
- 3 Serial number (ser. no.)
- 4 Extended order code (ext. ord. cd.)
- 5 Flow; nominal diameter of the sensor; pressure rating; nominal pressure; system pressure; medium temperature range; material of liner and electrodes
- 6 Approval information for explosion protection, Pressure Equipment Directive and degree of protection
- 7 Document number of safety-related supplementary documentation
- 8 2-D matrix code
- 9 Manufacturing date: year-month
- 10 Flow direction
- 11 CE mark, C-Tick
- 12 Permitted ambient temperature (T_a)
- 13 Name of the sensor

Transport

Protective packaging

Protective covers or protective caps are fitted on the process connections to protect against damage and dirt.

Transporting in the original packaging

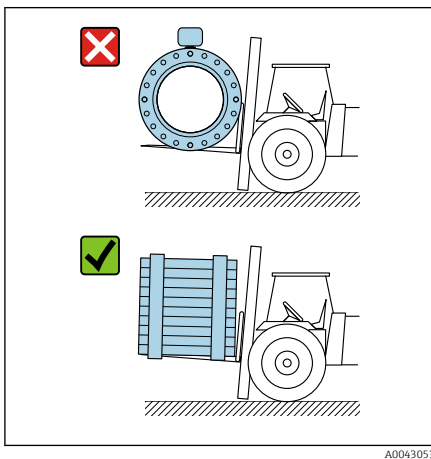

A0043053

NOTICE

Original packaging is missing!

Damage to the magnetic coil.

- ▶ Only lift and transport the device in the original packaging.

Transporting with lifting lugs

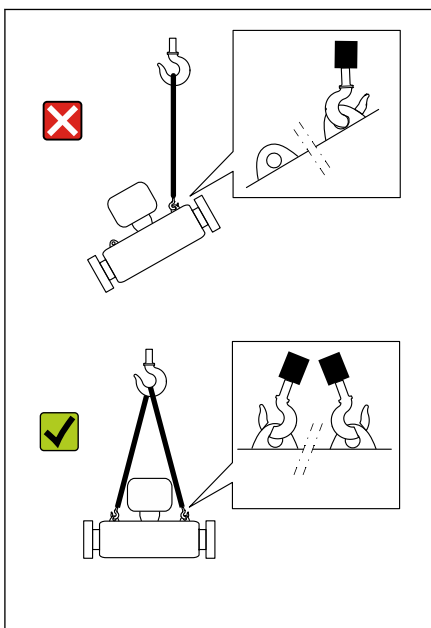

A0043058

⚠ DANGER

Potentially life-threatening hazard from suspended loads!

The device could fall.

- ▶ Secure the device against slipping and turning.
- ▶ Do not move suspended loads over people.
- ▶ Do not move suspended loads over unprotected areas.

NOTICE

Lifting equipment incorrectly attached!

Lifting equipment attached on one side only can damage the device.

- ▶ Attach lifting equipment to both lifting lugs.

Transporting without lifting lugs

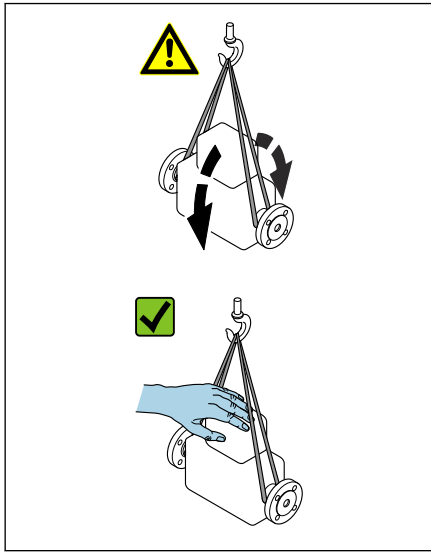

A0043054

⚠ DANGER

Potentially life-threatening hazard from suspended loads!

The device could fall.

- ▶ Secure the device against slipping and turning.
- ▶ Do not move suspended loads over people.
- ▶ Do not move suspended loads over unprotected areas.

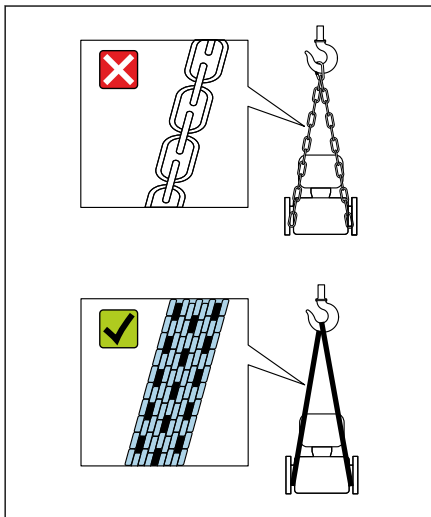

A0043055

NOTICE

Incorrect lifting equipment can damage the device!

The use of chains as hoists can damage the device.

- ▶ Use textile hoists.

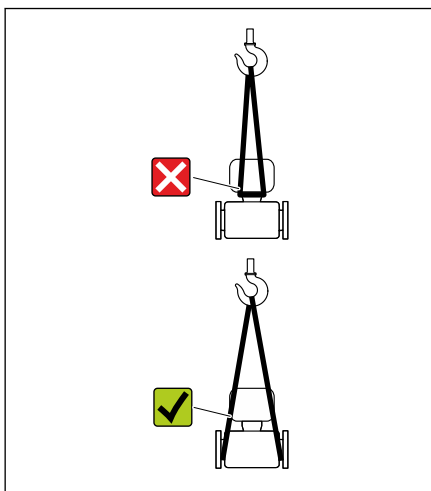

A0043056

NOTICE

Lifting equipment incorrectly attached!

Lifting equipment attached to unsuitable points can damage the device.

- ▶ Attach lifting equipment to both process connections of the device.

Checking the storage conditions

Are the protective covers or protection caps on the process connections?	<input type="checkbox"/>
Is the device in the original packaging?	<input type="checkbox"/>
Is the device protected against sunlight?	<input type="checkbox"/>
Is it guaranteed that the device is not stored outdoors?	<input type="checkbox"/>
Is the device stored in a dry and dust-free place?	<input type="checkbox"/>
Does the storage temperature match the device ambient temperature specified on the nameplate?	<input type="checkbox"/>
Is the possibility of moisture/condensation collecting on the device and original packaging as a result of variations in temperature ruled out?	<input type="checkbox"/>

Recycling of packaging materials

All packaging materials and packaging aids must be recycled as specified by national regulations.

- Stretch wrap: polymer in accordance with EU Directive 2002/95/EC (RoHS)
- Crate: wood in accordance with ISPM 15 standard, confirmed by IPPC logo
- Cardboard box: in accordance with European Packaging Directive 94/62/EC, confirmed by Resy symbol
- Disposable pallet: plastic or wood
- Packaging straps: plastic
- Adhesive strips: plastic
- Padding: paper

Product design

Compact version

The transmitter and sensor form a mechanical unit.

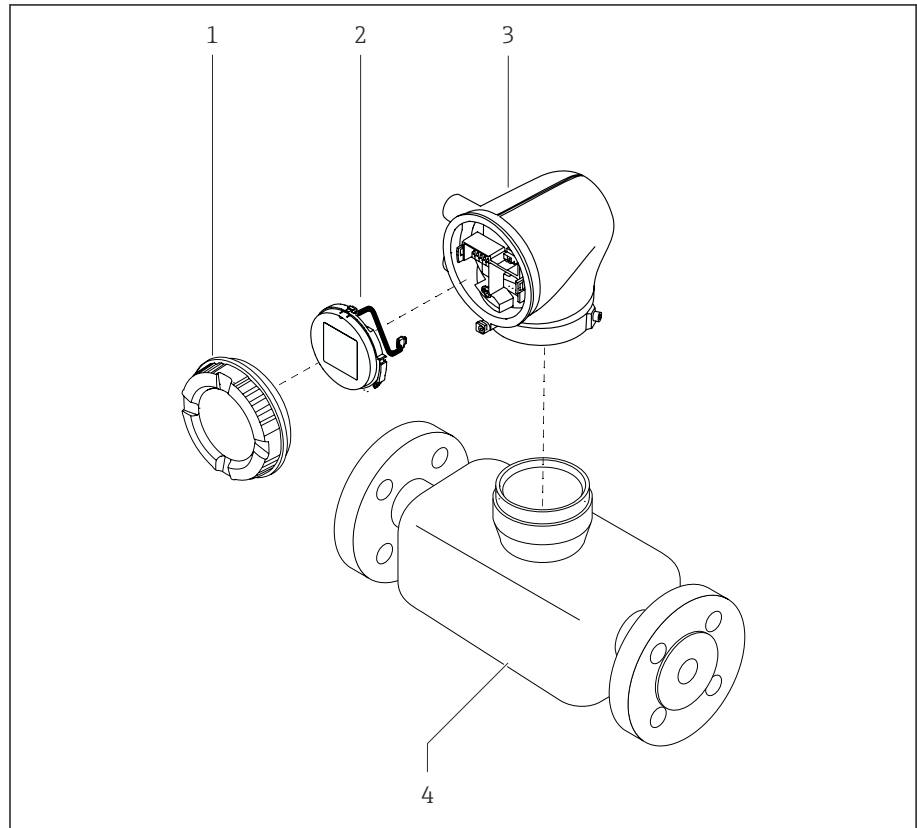

A0043525

3 Main device components

- 1 Housing cover
- 2 Display module
- 3 Transmitter housing
- 4 Sensor

Remote version

The transmitter and sensor are installed in physically separate locations.

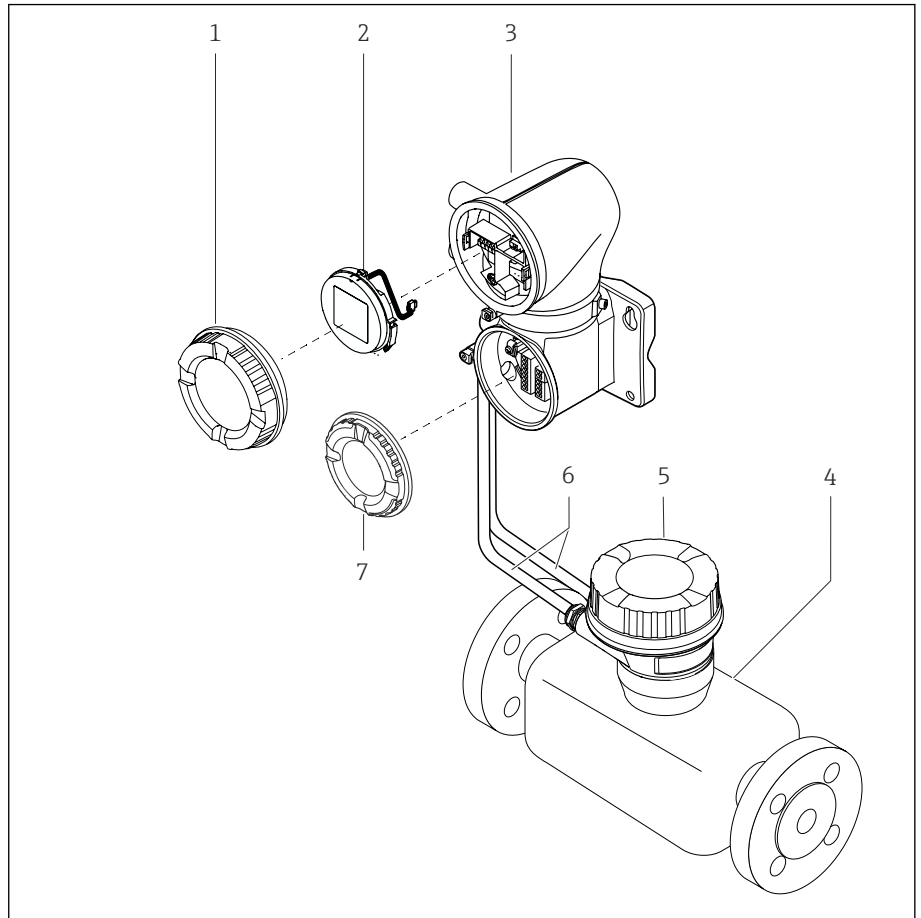

A0043524

4 Main device components

- 1 Housing cover
- 2 Display module
- 3 Transmitter housing
- 4 Sensor
- 5 Sensor connection housing
- 6 Connecting cable consisting of coil current cable and electrode cable
- 7 Connection compartment cover

Firmware history

List of firmware versions and changes since previous version

Firmware version 01.00.zz		
Release date	06.2024	Original firmware
Version of the Operating Instructions	01.24	
Order code for "Firmware version"	Option 76	

Device history and compatibility

List of device models and changes since previous model

Device model A1		
Release	2025-12-15	-
Version of the Operating Instructions	01.25	
Compatibility with previous model	-	

4 Installation procedure

Installation conditions	26
Device installation	33
Post-installation check	37

Installation conditions

Flow direction

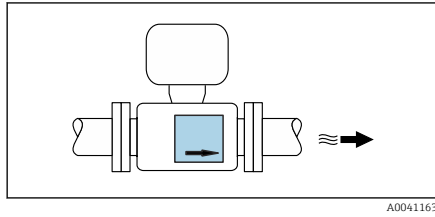

A0041163

Install the device in the direction of flow.

i Note the direction of arrow on the nameplate.

Installation with inlet runs and outlet runs

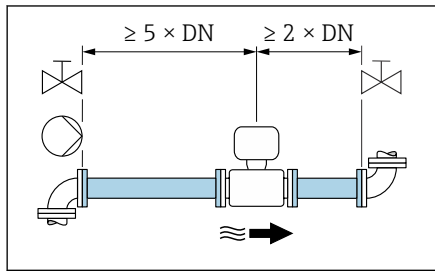

A0028997

Ensure straight, undisturbed inlet and outlet runs.

i To avoid negative pressure and to comply with accuracy specifications, install the sensor upstream from assemblies that produce turbulence (e.g. valves, T-sections) and downstream from pumps → *Installation near pumps*, 30.

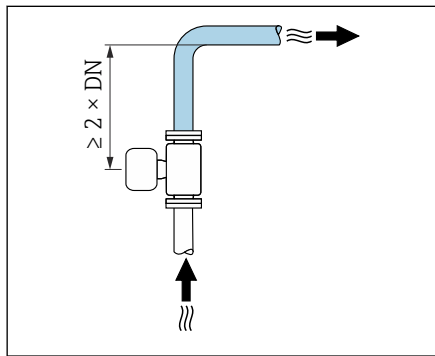

A0042132

Keep a sufficient distance to the next pipe elbow.

Installation without inlet runs and outlet runs

Depending on the device design and installation location, the inlet and outlet runs can be reduced or omitted entirely.

i **Maximum measurement error**
When the device is installed with the inlet and outlet runs described, a maximum measurement error of $\pm 0.5\%$ of the reading ± 1 mm/s (0.04 in/s) can be guaranteed.

Devices and possible order options

Order code for "Electrodes"		
Option	Description	Design
J	1.4435/316L, pointed for 0 x DN inlet/outlet runs	0 x DN full-bore design ¹⁾
K	Alloy C22, pointed for 0 x DN inlet/outlet runs	
L	1.4435/316L for 0 x DN inlet/outlet runs	
M	Alloy C22 for 0 x DN inlet/outlet runs	
N	Tantalum for 0 x DN inlet/outlet runs	

Order code for "Electrodes"		
Option	Description	Design
P	Platinum for 0 x DN inlet/outlet runs	
Q	Titanium for 0 x DN inlet/outlet runs	

1) "Full-bore" indicates a measuring tube cross-section corresponding to the nominal diameter without constriction. This means there is no pressure loss.

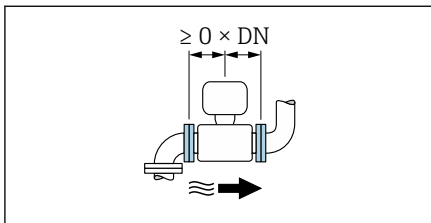

Installation before or after bends
Installation without inlet and outlet runs is possible.

A0032859

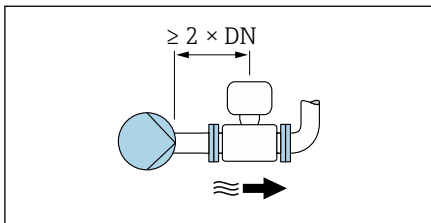

Installation downstream of pumps
Installation without inlet and outlet runs is possible.

i An inlet run of $\geq 2 \times DN$ is recommended.

A0045530

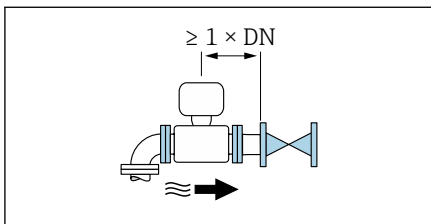

Installation upstream of valves
Installation without inlet and outlet runs is possible.

i An outlet run of $\geq 1 \times DN$ is recommended.

A0045531

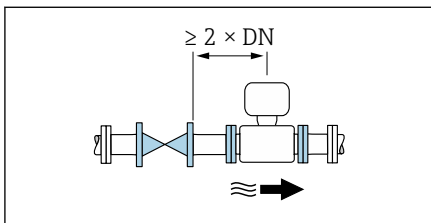

Installation downstream of valves
The device can be installed without inlet and outlet runs if the valve is 100% open during operation.

i An inlet run of $\geq 2 \times DN$ is recommended if the valve is 100% open during operation.

A0045786

Orientations

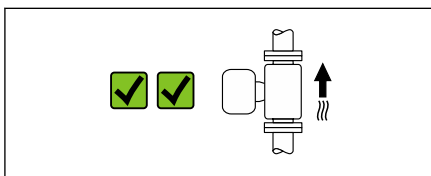

Vertical orientation, upward direction of flow
For all applications.

A0041159

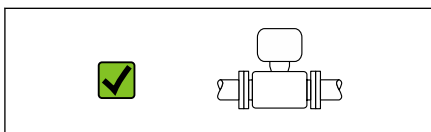

Horizontal orientation, transmitter at top

This orientation is suitable for the following applications:

- For medium and low process temperatures, in order to maintain the minimum ambient temperature for the transmitter.
- For empty pipe detection, even in the case of empty or partially filled measuring pipes.

A0041160

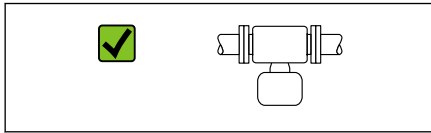

Horizontal orientation, transmitter at bottom

This orientation is suitable for the following applications:

- For medium and high process temperatures, in order to maintain the maximum ambient temperature for the transmitter.
- To prevent the electronics module from overheating in the case of a sharp rise in temperature (e.g. CIP or SIP processes), install the measuring instrument with the transmitter component pointing downwards.

This orientation is not suitable for the following applications:

If empty pipe detection is to be used.

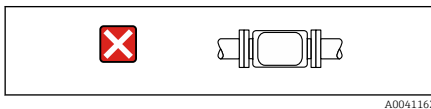

Horizontal orientation, transmitter at side

This orientation is not suitable

Vertical

Optimum for self-emptying pipe systems and for use in conjunction with empty pipe detection.

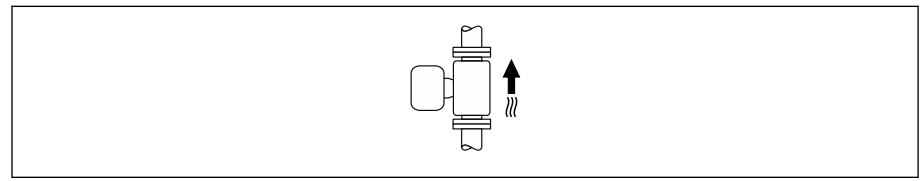

Horizontal

- Ideally, the measuring electrode plane should be horizontal. This prevents brief insulation of the measuring electrodes by entrained air bubbles.
- Empty pipe detection only works if the transmitter housing is pointing upwards as otherwise there is no guarantee that the empty pipe detection function will actually respond to a partially filled or empty measuring tube.

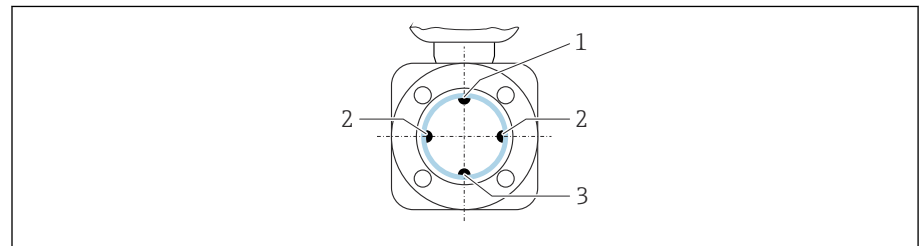

- 1 EPD electrode for empty pipe detection
- 2 Measuring electrodes for signal detection
- 3 Reference electrode for potential equalization

i Measuring instruments with tantalum or platinum electrodes can be ordered without an EPD electrode. In this case, empty pipe detection is performed via the measuring electrodes.

Mounting locations

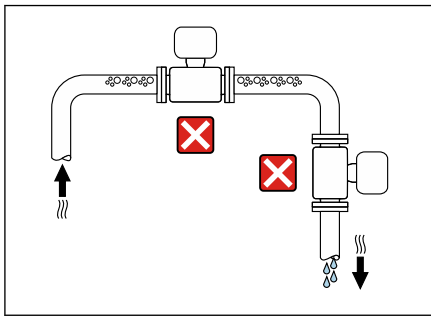

- Do not install the device at the highest point of the pipe.
- Do not install the device upstream from a free pipe outlet in a down pipe.

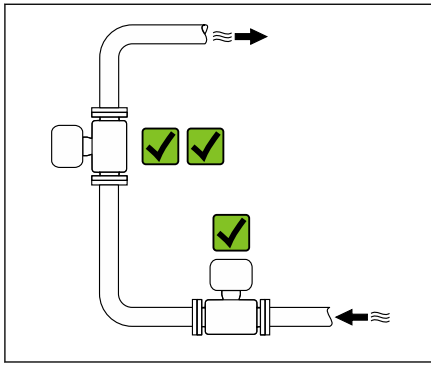

The device should ideally be installed in an ascending pipe.

Installation near control valves

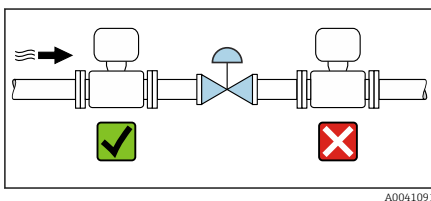

Install the device in the direction of flow upstream from the control valve.

Installation upstream from a down pipe

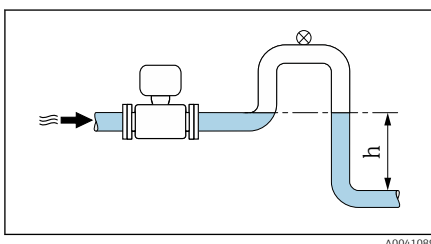

NOTICE

Negative pressure in the measuring pipe can damage the liner!

- ▶ If installing upstream from down pipes with a length $h \geq 5 \text{ m}$ (16.4 ft): install a siphon with a vent valve downstream from the device.

i This arrangement prevents the flow of liquid stopping in the pipe and air entrainment.

Installation with partially filled pipes

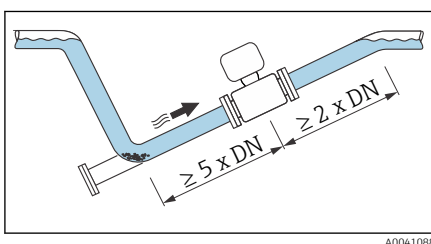

- Partially filled pipes with a gradient require a drain-type configuration.
- The installation of a cleaning valve is recommended.

Installation near pumps

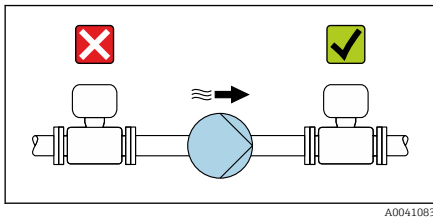

A0041083

NOTICE

A vacuum in the measuring tube can damage the liner!

- ▶ Install the device in the direction of flow downstream from the pump.
- ▶ Install pulsation dampers if reciprocating, diaphragm or peristaltic pumps are used.



Information on the measuring system's resistance to vibration and shock
 → *Vibration resistance and shock resistance*, 97

Installation of heavy devices

Support is required with nominal diameters of DN ≥ 350 (14") and higher.

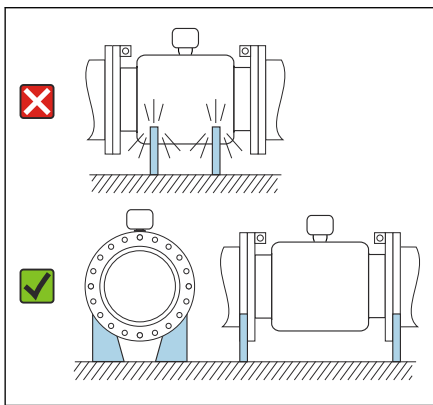

A0041087

NOTICE

Damage to the device!

If incorrect support is provided, the sensor housing could buckle and the internal magnetic coils could be damaged.

- ▶ Only provide supports at the pipe flanges.

Pipe vibrations

A remote version is recommended in the event of strong pipe vibrations.

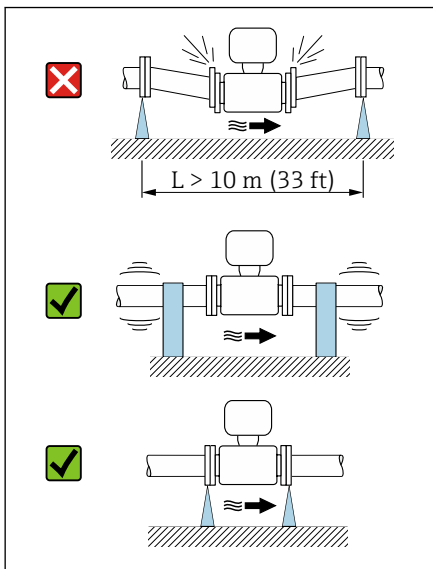

A0041092

NOTICE

Pipe vibrations can damage the device!

- ▶ Do not expose the device to strong vibrations.
- ▶ Support the pipe and fix it in place.
- ▶ Support the device and fix it in place.
- ▶ Mount the sensor and transmitter separately.

Adapters

Suitable adapters (double-flange reducers) can be used to install the sensor in larger-diameter pipes. The resulting higher rate of flow improves measuring accuracy with very slow-moving media.

i The nomogram shown here can be used to calculate the pressure loss caused by reducers and expanders. It only applies to liquids with a viscosity similar to that of water.

1. Calculate the ratio of the diameters d/D .
2. Determine the flow velocity after the reduction.
3. From the chart, determine the pressure loss as a function of the flow velocity v and the d/D ratio.

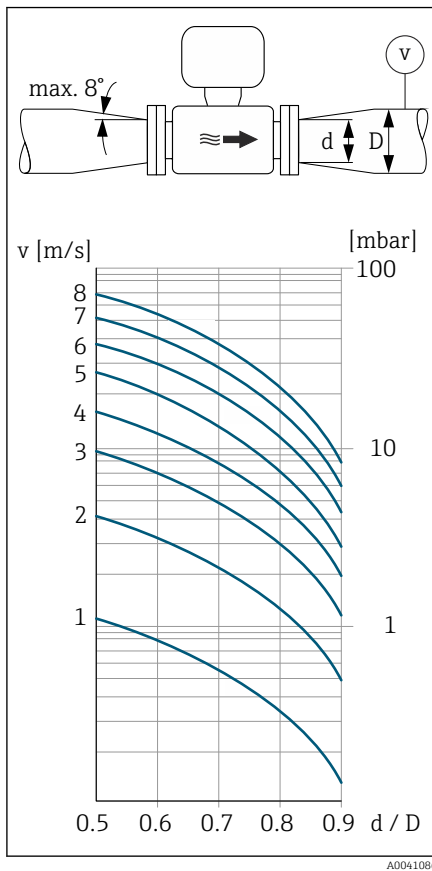

Seals

Note the following when installing seals:

- For "PFA" liner: no seal is required.
- For "PTFE" liner: no seal is required.
- For DIN flanges: only install seals according to DIN EN 1514-1.

Thermal insulation

The sensor and pipe must be insulated in the event of very hot media. The insulation helps to slow energy loss and prevent injuries from accidental contact with hot pipes.

NOTICE

If the meter electronics overheat this can damage the device!

- ▶ Keep the housing support completely free (heat dissipation).
- ▶ Provide insulation but make sure it does not go beyond the upper edge of the two sensor half-shells.

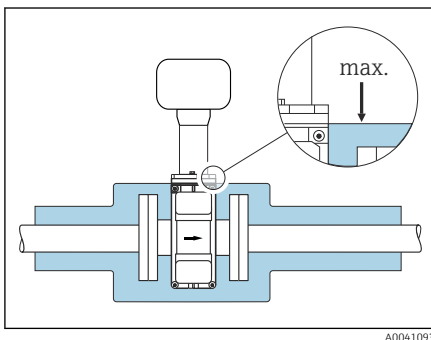

Magnetism and static electricity

Do not install the device near magnetic fields, e.g. Engines, transformers.

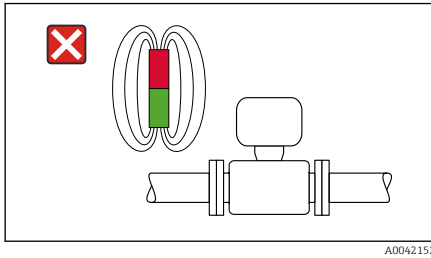

Outdoor use

- Avoid exposure to direct sunlight.
- Install in a location protected from sunlight.
- Avoid direct exposure to weather conditions.
- Use a weather protection cover → *Transmitter*, 146.

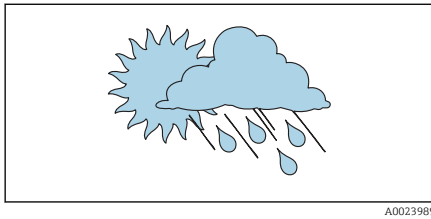

Immersion in water

i Only the remote version with IP68, type 6P, is suitable for immersion in water.

NOTICE

If the maximum water depth and operating duration are exceeded, this will damage the device!

- ▶ Observe the maximum water depth and operating duration.

Order code for "Sensor option", option CQ "IP68, Type 6P, factory-potted"

- For permanent operation of the device under rain or surface water
- Operation at a maximum depth of 3 m (10 ft)

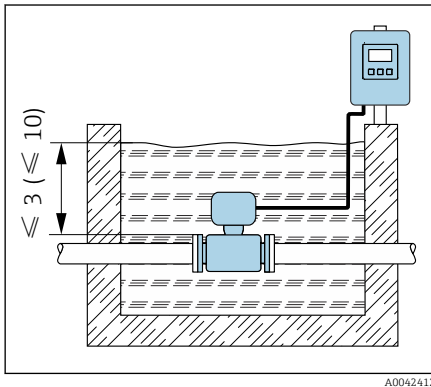

Use in buried applications

i Only the remote version with IP68 is suitable for use in buried applications.

Order code for "Sensor option", options CD, CE

The device can be used in buried applications without the need to implement additional precautionary measures on the device.

Installation is performed according to regional installation regulations.

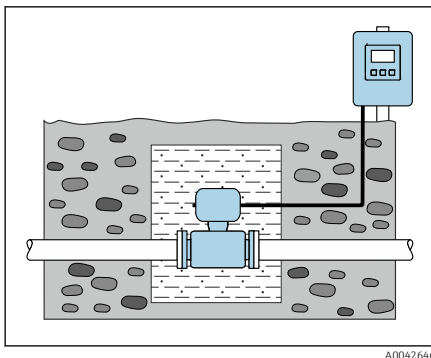

Device installation

Preparing the device

1. Remove the entire transportation packaging.
2. Remove protective covers or protective caps on the device.

Installing seals

⚠ WARNING

Improper process sealing can put staff at risk!

- ▶ Check whether the seals are clean and undamaged.

NOTICE

Incorrect installation can lead to incorrect measurement results!

- ▶ The internal diameter of the seal must be greater than or equal to that of the process connection and pipe.
- ▶ Fit the seals and measuring pipe centrally.
- ▶ Make sure that the seals do not protrude into the pipe cross-section.

NOTICE

Formation of an electrically conductive layer on the inside of the measuring pipe!

Measuring signal short circuit possible.

- ▶ Do not use electrically conductive sealing compounds such as graphite.

Installing the ground disks

- In the case of plastic pipes or pipes with an insulating liner, grounding is via ground disks.
- Observe the information for the use of ground disks → *Ensuring potential equalization*, ☰ 46.
- Ground disks can be ordered separately from Endress+Hauser → *Device-specific accessories*, ☰ 146.

Installing the sensor

1. Ensure that the direction of the arrow on the sensor matches the flow direction of the medium.
2. If using ground disks, comply with the Installation Instructions provided.
3. Observe tightening torques. Maximum or nominal screw tightening torques apply depending on the flange standard and flange size → *Screw tightening torques*, ☰ 151.
4. Install and turn the device or transmitter housing in such a way that the cable entries point down or to the side.

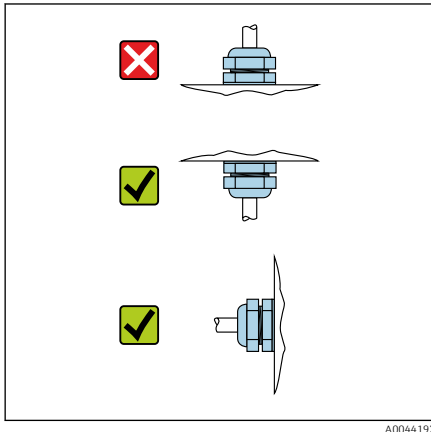

A0044192

Turning the transmitter housing

Order code for "Housing", option
"Aluminum"

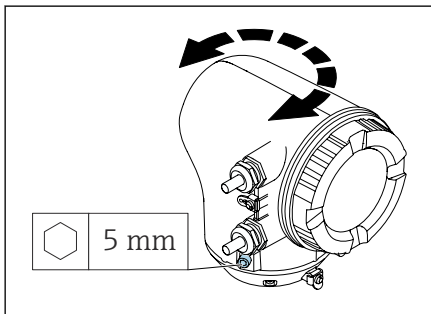

A0041095

1. Loosen the fixing screws on both sides of the transmitter housing.

2. **NOTICE**

Overrotation of the transmitter housing!

Interior cables are damaged.

- ▶ Turn the transmitter housing a maximum of 180° in each direction.

Turn the transmitter housing to the desired position.

3. Tighten the screws in the logically reverse sequence.

Order code for "Housing", option
"Polycarbonate"

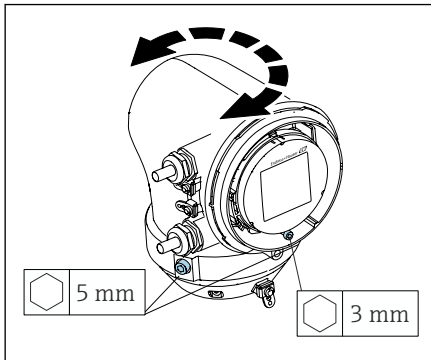

A0050149

1. Loosen the screw on the housing cover.
2. Open the housing cover.
3. Loosen the grounding screw (below the display).
4. Loosen the fixing screws on both sides of the transmitter housing.

5. **NOTICE**

Overrotation of the transmitter housing!

Interior cables are damaged.

- ▶ Turn the transmitter housing a maximum of 180° in each direction.

Turn the transmitter housing to the desired position.

6. Tighten the screws in the logically reverse sequence.

Mounting the transmitter on the wall

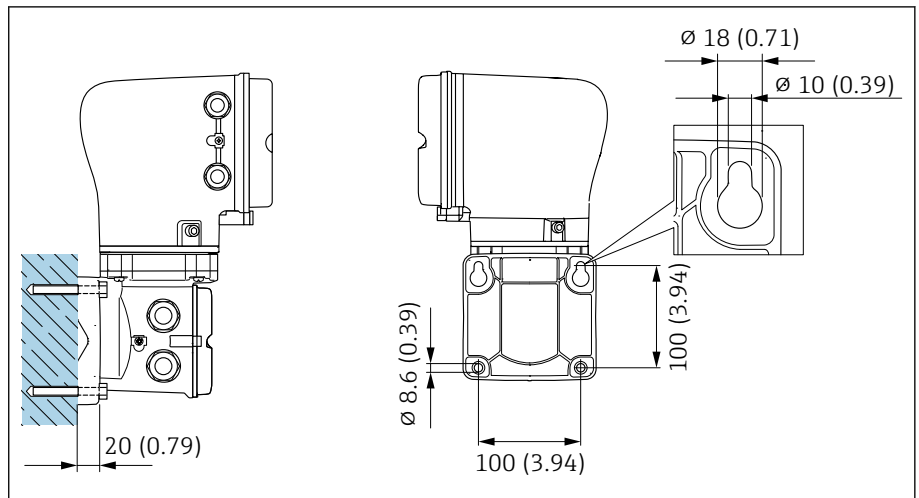

A0043473

5 Unit mm (in)

NOTICE

Ambient temperature too high!

If the electronics overheat this can damage the transmitter housing.

- ▶ Do not exceed the permissible temperature range for the ambient temperature.
- ▶ Use a weather protection cover → *Transmitter*, 146.
- ▶ Mount the device correctly.

Mounting the transmitter on a post

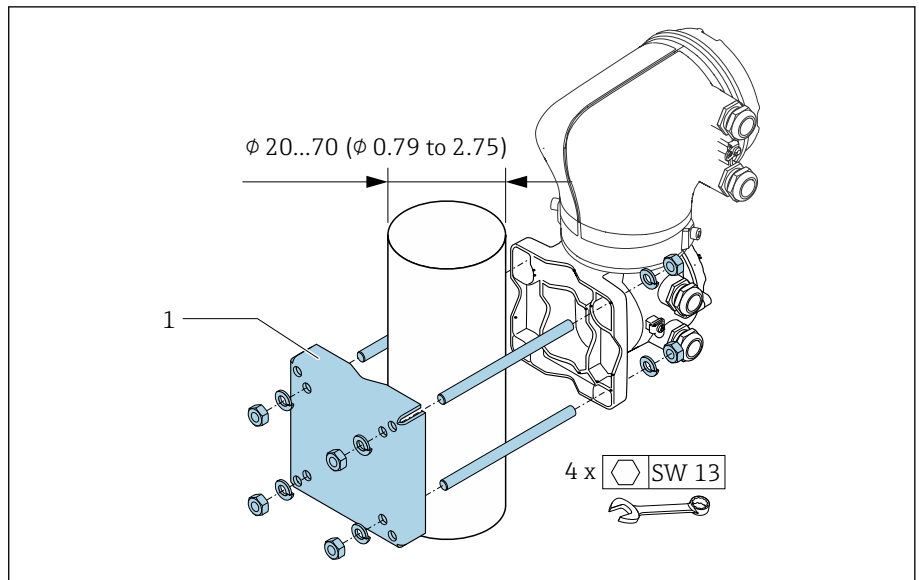

A0043471

6 Unit mm (in)

NOTICE**Ambient temperature too high!**

If the electronics overheat this can damage the transmitter housing.

- ▶ Do not exceed the permissible temperature range for the ambient temperature.
- ▶ Use a weather protection cover → *Transmitter*,  146.
- ▶ Mount the device correctly.

Post-installation check

Is the device undamaged (visual inspection)?	<input type="checkbox"/>
Does the device comply with the measuring point specifications? For example: <ul style="list-style-type: none">■ Process temperature■ Process pressure■ Ambient temperature■ Measuring range	<input type="checkbox"/>
Has the correct orientation been selected for the device?	<input type="checkbox"/>
Does the direction of the arrow on the device match the flow direction of the medium?	<input type="checkbox"/>
Is the device protected against precipitation and sunlight?	<input type="checkbox"/>
Are the screws tightened with the correct tightening torque?	<input type="checkbox"/>

5 Electrical connection

Connecting requirements	40
Connecting cable connection	41
Transmitter connection	46
Ensuring potential equalization	46
Removing a cable	50
Hardware settings	50
Post-connection check	51

Connecting requirements

Notes on the electrical connection

WARNING

Live parts!

Incorrect work performed on the electrical connections can result in an electric shock.

- ▶ Have electrical connection work carried out by appropriately trained specialists only.
- ▶ Comply with applicable federal/national installation codes and regulations.
- ▶ Comply with national and local workplace safety regulations.
- ▶ Ground the device carefully and provide potential equalization.
- ▶ Connect protective earthing to all outer ground terminals.

Additional protective measures

The following protective measures are required:

- Set up a disconnecting device (switch or power-circuit breaker) to easily disconnect the device from the supply voltage.
- The DC power unit must be tested to ensure it meets technical safety requirements (e.g. PELV, SELV) with limited power sources (e.g. class 2).
- Plastic sealing plugs act as safeguards during transportation and must be replaced by suitable, individually approved installation material.
- Connection examples: → *Examples of electric terminals*,  158

Connecting cable connection

Preparing the connecting cable

Transmitter

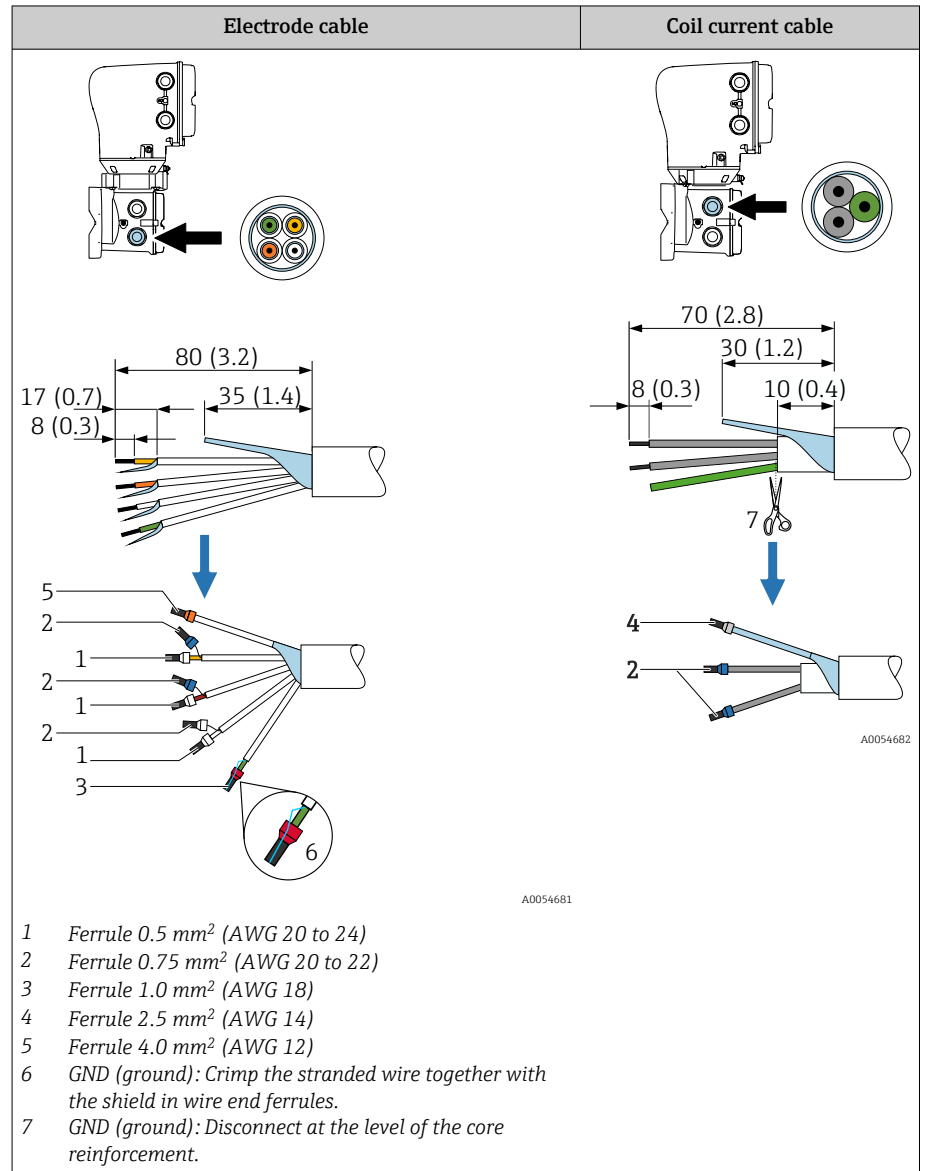

Sensor

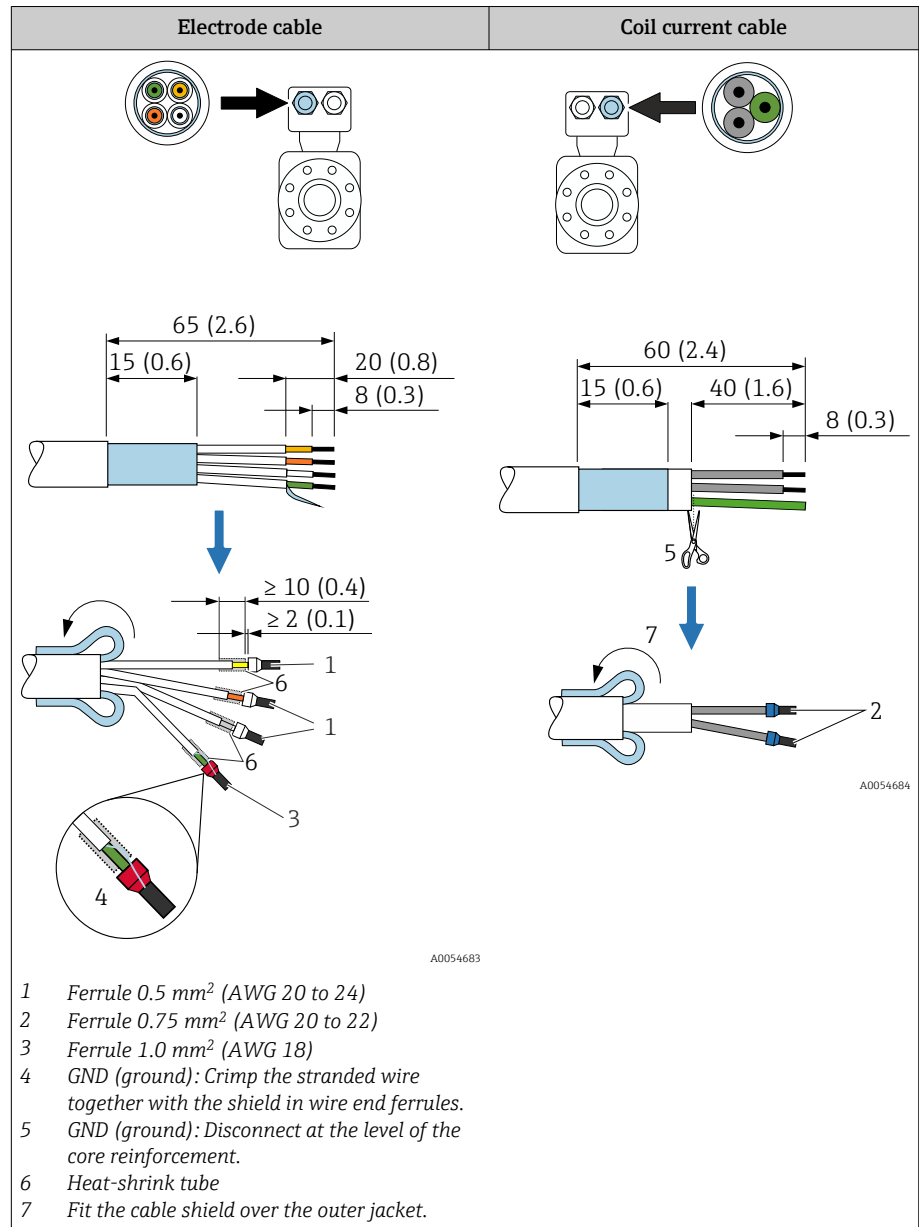

1. Make sure that the ferrules do not touch the cable shields on the sensor side. Minimum distance = 1 mm (exception: green "GND" cable)
2. A: Terminate the electrode cable.
3. B: Fit ferrules over the strands and press in place.
4. Fit the cable shield on the sensor side over the outer jacket.
5. Insulate the cable shield on the transmitter side, e.g. heat shrink tube.

Connecting the connecting cable

Connecting cable terminal assignment

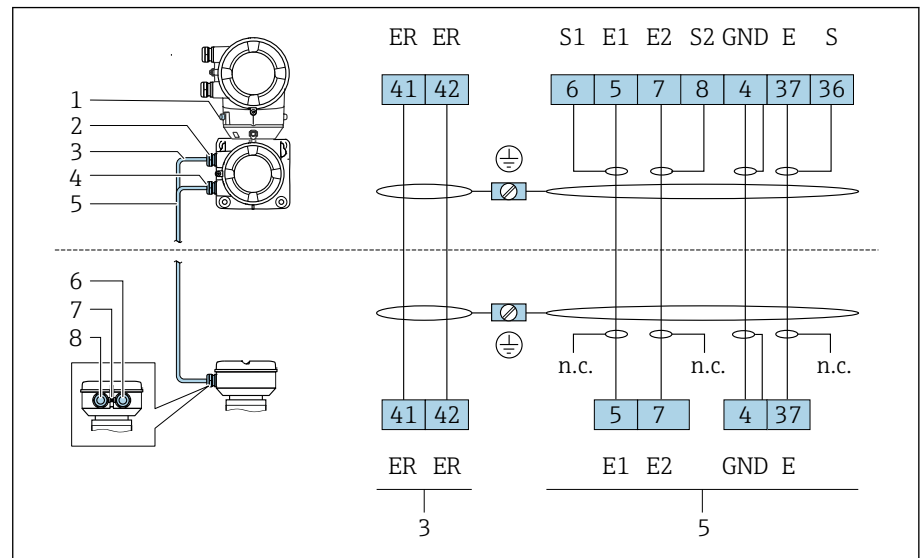

A0043474

- 1 Outer ground terminal
- 2 Transmitter housing: cable entry for coil current cable
- 3 Coil current cable
- 4 Transmitter housing: cable entry for electrode cable
- 5 Electrode cable
- 6 Sensor connection housing: cable entry for electrode cable
- 7 Outer ground terminal
- 8 Sensor connection housing: cable entry for coil current cable

Wiring the sensor connection housing

NOTICE

Incorrect wiring can damage the electronic components!

- ▶ Only connect sensors and transmitters with identical serial numbers.
- ▶ Connect the sensor connection housing and the transmitter housing to the potential equalization of the facility via the outer ground terminal.
- ▶ Connect the sensor and transmitter to the same potential.

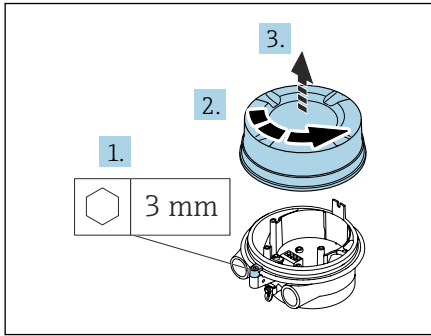

A0044138

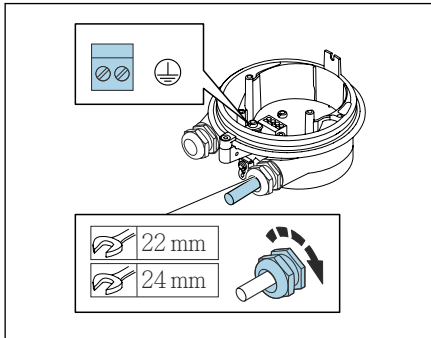

A0044139

1. Loosen the Allen key of the securing clamp.
2. Open the connection compartment cover counterclockwise.

NOTICE

If the sealing ring is missing, the housing is not sealed tight!

Damage to the device.

- ▶ Do not remove the sealing ring from the cable entry.

3. Feed the coil current cable and electrode cable through the corresponding cable entry.
4. Adjust the cable lengths.
5. Connect the cable shield to the inner ground terminal.
6. Strip the cable and cable ends.
7. Fit ferrules over the strands and press in place.
8. Connect the coil current cable and the electrode cable as per the terminal assignment.
9. Tighten the cable glands.
10. Close the connection compartment cover.
11. Fasten the securing clamp.

Wiring the transmitter housing**NOTICE**

Incorrect wiring can damage the electronic components!

- ▶ Only connect sensors and transmitters with identical serial numbers.
- ▶ Connect the sensor connection housing and the transmitter housing to the potential equalization of the facility via the outer ground terminal.
- ▶ Connect the sensor and transmitter to the same potential.

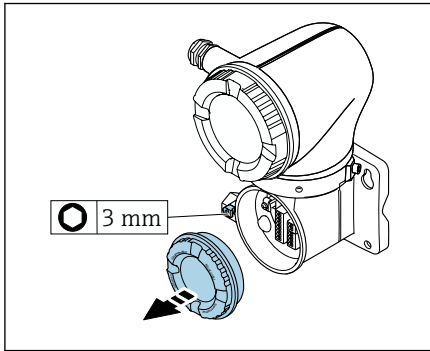

1. Loosen the Allen key of the securing clamp.
2. Open the connection compartment cover counterclockwise.

NOTICE

If the sealing ring is missing, the housing is not sealed tight!
Damage to the device.

- ▶ Do not remove the sealing ring from the cable entry.

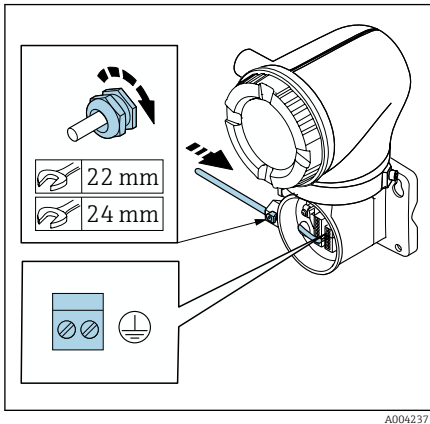

3. Feed the coil current cable and electrode cable through the corresponding cable entry.
4. Adjust the cable lengths.
5. Connect the cable shields to the inner ground terminal.
6. Strip the cable and cable ends.
7. Fit ferrules over the strands and press in place.
8. Connect the coil current cable and the electrode cable as per the terminal assignment.
9. Tighten the cable glands.
10. Close the connection compartment cover.
11. Fasten the securing clamp.

Transmitter connection

Transmitter terminal connections

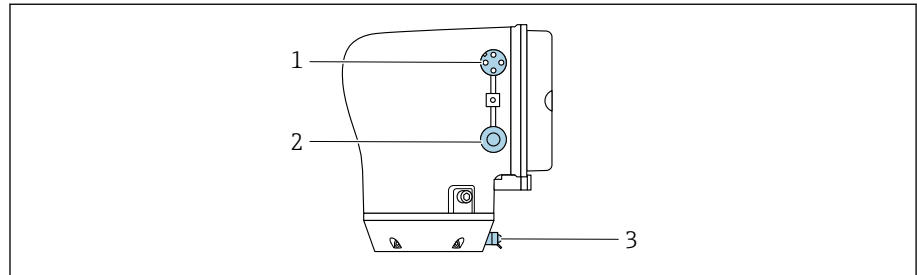

A0053767

- 1 M12 plug for power supply (supply voltage) and signals (IO-Link)
- 2 Dummy plug
- 3 Outer ground terminal

Pin assignment of IO-Link device plug

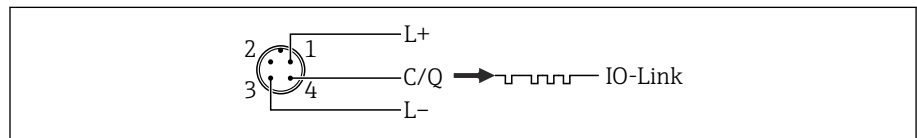

A0053891

7 M12 A-coded (IEC 61076-2-101)

- 1 PIN 1: power supply
- 2 PIN 2: not used
- 3 PIN 3: reference potential for power supply/output
- 4 PIN 4: output 1 (IO-link)

Wiring the transmitter

- i** Pay attention to the requirements for the power supply cable and signal cable → *Requirements for connecting cable*, 93 .
- i**
 - Connect protective earthing to the outer signal terminals.
 - Connect the IO-Link signal cable to M12.

Ensuring potential equalization

Introduction

Correct potential equalization (equipotential bonding) is a prerequisite for stable and reliable flow measurement. Inadequate or incorrect potential equalization can result in device failure and present a safety hazard.

The following requirements must be observed to ensure correct, trouble-free measurement:

- The principle that the medium, the sensor and the transmitter must be at the same electric potential applies.
- Take in-company grounding guidelines, materials and the grounding conditions and potential conditions of the pipe into consideration.
- The necessary potential equalization connections must be established using a ground cable with a minimum cross-section of 6 mm² (0.0093 in²). Also use a cable lug.
- In the case of remote device versions, the ground terminal in the example always refers to the sensor and not to the transmitter.

i Accessories such as ground cables and ground disks can be ordered from Endress+Hauser → *Device-specific accessories*, 146

i For devices intended for use in hazardous areas, observe the instructions in the Ex documentation (XA).

Abbreviations used

- PE (Protective Earth): potential at the potential equalization terminals of the device
- P_P (Potential Pipe): potential of the pipe, measured at the flanges
- P_M (Potential Medium): potential of the medium

Connection examples for standard situations

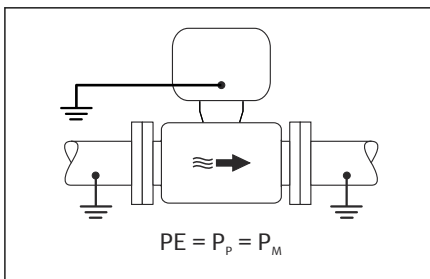

Unlined and grounded metal pipe

- Potential equalization is via the measuring tube.
- The medium is set to ground potential.

Starting conditions:

- Pipes are correctly grounded on both sides.
 - Pipes are conductive and at the same electric potential as the medium
- ▶ Connect the connection housing of the transmitter or sensor to ground potential via the ground terminal provided for this purpose.

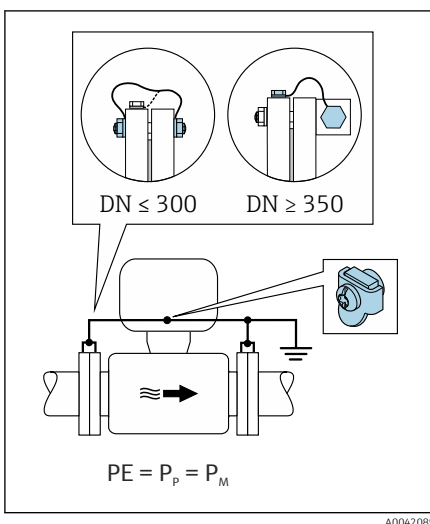

Unlined metal pipe

- Potential equalization is via the ground terminal and pipe flanges.
- The medium is set to ground potential.

Starting conditions:

- Pipes are not sufficiently grounded.
- Pipes are conductive and at the same electric potential as the medium

1. Connect both sensor flanges to the pipe flange via a ground cable and ground them.
2. Connect the connection housing of the transmitter or sensor to ground potential via the ground terminal provided for this purpose.
3. For DN ≤ 300 (12"): Mount the ground cable directly on the conductive flange coating of the sensor with the flange screws.
4. For DN ≥ 350 (14"): Mount the ground cable directly on the metal transport bracket. Observe the screw tightening torques: see the Brief Operating Instructions for the sensor.

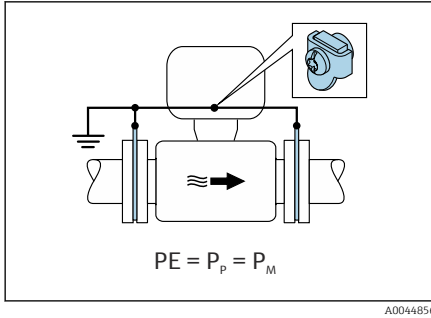

Plastic pipe or pipe with insulating liner

- Potential equalization is via the ground terminal and ground disks.
- The medium is set to ground potential.

Starting conditions:

- The pipe has an insulating effect.
- Low-impedance medium grounding close to the sensor is not guaranteed.
- Equalizing currents through the medium cannot be ruled out.

1. Connect the ground disks via the ground cable to the ground terminal of the connection housing of the transmitter or sensor.
2. Connect the connection to ground potential.

Connection example with the potential of medium not equal to potential equalization connection without the "Floating measurement" option

In these cases, the medium potential can differ from the potential of the device.

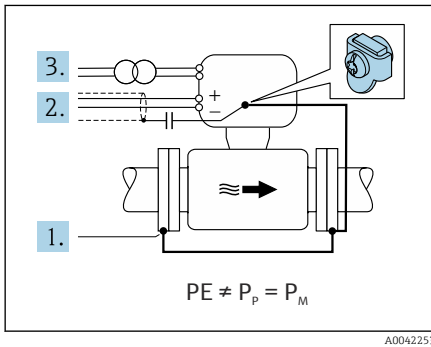

Metal, ungrounded pipe

The sensor and transmitter are installed in a way that provides electrical insulation from PE, e.g. applications for electrolytic processes or systems with cathodic protection.

Starting conditions:

- Unlined metal pipe
- Pipes with an electrically conductive liner

1. Connect the pipe flanges and transmitter via the ground cable.
2. Route the shielding of the signal lines via a capacitor (recommended value 1.5µF/50V).
3. Device connected to power supply such that it is floating in relation to the potential equalization connection (isolation transformer). This measure is not required in the case of 24V DC supply voltage without PE (= SELV power unit).

Connection examples with the potential of medium not equal to potential equalization connection with the "Floating measurement" option

In these cases, the medium potential can differ from the potential of the device.

Introduction

The "Floating measurement" option enables the galvanic isolation of the measuring system from the device potential. This minimizes harmful equalizing currents caused by differences in potential between the medium and the device.

The "Floating measurement" option is optionally available: order code for "Sensor option", option CV

Operating conditions for use of the "Floating measurement" option

Device version	Compact version and remote version (length of connecting cable ≤ 10 m)
Differences in voltage between medium potential and device potential	As small as possible, usually in the mV range
Alternating voltage frequencies in the medium or at ground potential (PE)	Below typical power line frequency in the country

i To achieve the specified conductivity measuring accuracy, a conductivity calibration is recommended when the device is installed.

A full pipe adjustment is recommended when the device is installed.

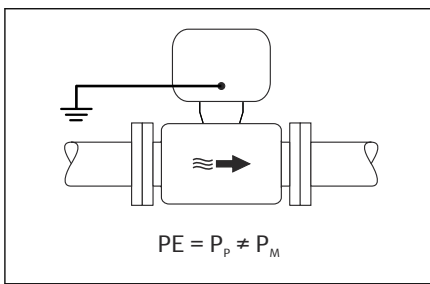

Plastic pipe

Sensor and transmitter are correctly grounded. A difference in potential can occur between the medium and potential equalization connection. Potential equalization between P_M and PE via the reference electrode is minimized with the "Floating measurement" option.

Starting conditions:

- The pipe has an insulating effect.
- Equalizing currents through the medium cannot be ruled out.

1. Use the "Floating measurement" option, while also observing the operating conditions for floating measurement.
2. Connect the connection housing of the transmitter or sensor to ground potential via the ground terminal provided for this purpose.

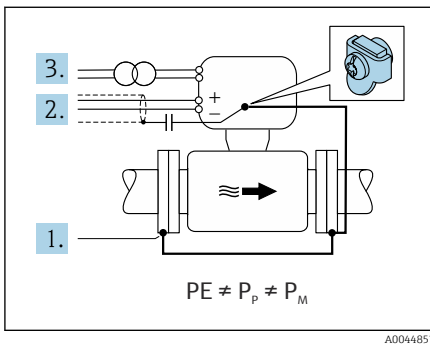

Metal, ungrounded pipe with insulating liner

The sensor and transmitter are installed in a way that provides electrical insulation from PE. The medium and pipe have different potentials. The "Floating measurement" option minimizes harmful equalizing currents between P_M and P_P via the reference electrode.

Starting conditions:

- Metal pipe with insulating liner
- Equalizing currents through the medium cannot be ruled out.

1. Connect the pipe flanges and transmitter via the ground cable.
2. Route the shielding of the signal cables via a capacitor (recommended value 1.5µF/50V).
3. Device connected to power supply such that it is floating in relation to the potential equalization connection (isolation transformer). This measure is not required in the case of 24V DC supply voltage without PE (= SELV power unit).
4. Use the "Floating measurement" option, while also observing the operating conditions for floating measurement.

Removing a cable

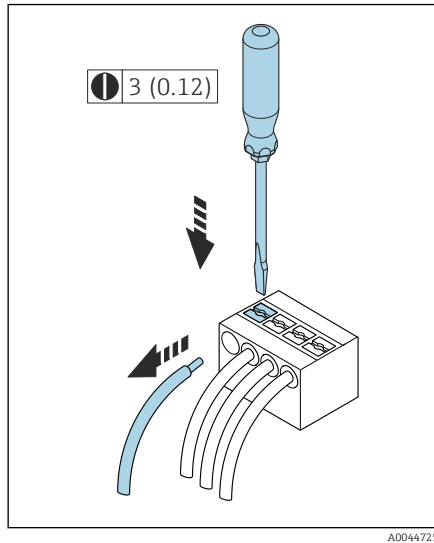

8 Engineering unit mm (in)

1. Use a flat-blade screwdriver to press down on the slot between the two terminal holes and hold.
2. Remove the cable end from the terminal.

Hardware settings

Enabling write protection

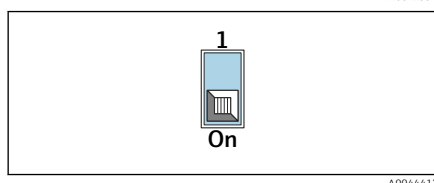
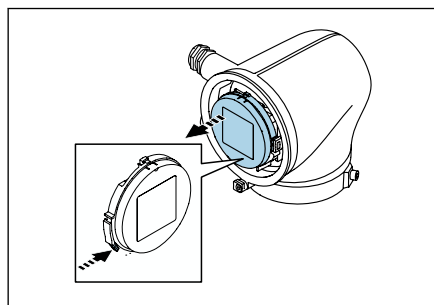
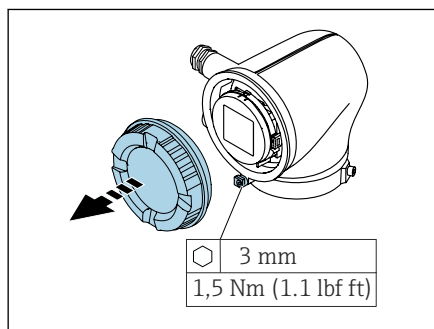

1. Loosen the Allen key of the securing clamp.
2. Open the housing cover counterclockwise.
3. Press the tab of the display module holder.
4. Remove the display module from the display module holder.
5. Set the write protection switch on the back of the display module to the **On** position.
 - ↳ Write protection is enabled.
6. Follow the sequence in the reverse order to reassemble.

Post-connection check

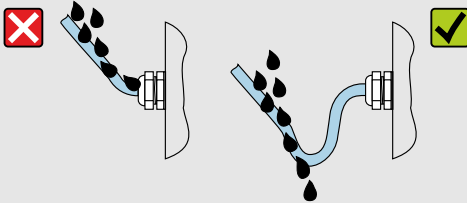
Only for remote version: Is the serial number on the nameplates of the connected sensor and transmitter identical?	<input type="checkbox"/>
Is the potential equalization established correctly?	<input type="checkbox"/>
Is the protective earthing established correctly?	<input type="checkbox"/>
Are the device and cable undamaged (visual check)?	<input type="checkbox"/>
Do the cables meet the requirements?	<input type="checkbox"/>
Is the terminal assignment correct?	<input type="checkbox"/>
Are all the cable glands installed, firmly tightened and leak-tight?	<input type="checkbox"/>
Are dummy plugs inserted in unused cable entries?	<input type="checkbox"/>
Are transportation plugs replaced by dummy plugs?	<input type="checkbox"/>
Are the housing screws and housing cover tightened?	<input type="checkbox"/>
Do the cables loop down before the cable gland ("water trap")?	<input type="checkbox"/>
 <p style="text-align: right; font-size: small;">A0042316</p>	<input type="checkbox"/>
Does the supply voltage match the specifications on the transmitter nameplate?	<input type="checkbox"/>

6 Operation

Overview of the operating options	54
Operation via SmartBlue app	54

Overview of the operating options

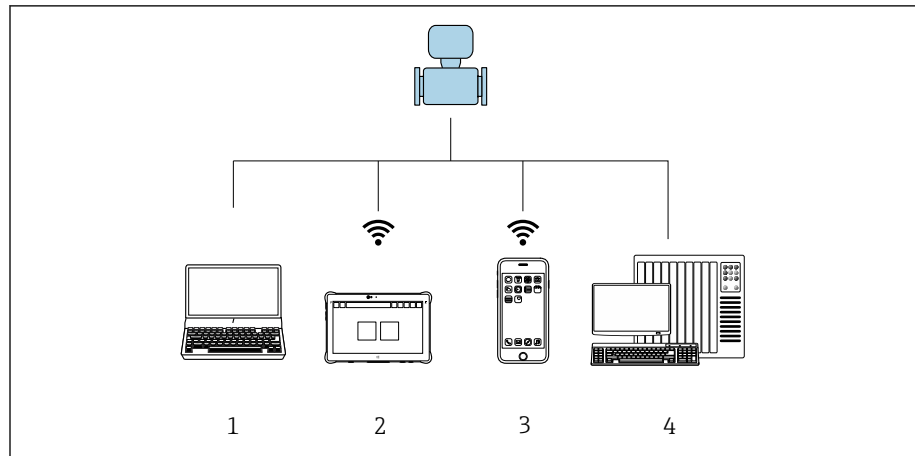

A0054834

- 1 Computer with operating tool, e.g. FieldCare, DeviceCare or IODD operating tools
- 2 Field Xpert SMT70 via Bluetooth, e.g. SmartBlue App
- 3 Tablet or smartphone via Bluetooth, e.g. SmartBlue App
- 4 Automation system, e.g. PLC

Operation via SmartBlue app

The device can be operated and configured with the SmartBlue App.

- The SmartBlue app must be downloaded onto a mobile device for this purpose
- For information on the compatibility of the SmartBlue app with mobile devices, see **Apple App Store (iOS devices)** or **Google Play Store (Android devices)**
- Incorrect operation by unauthorized persons is prevented by means of encrypted communication and password encryption.
- The Bluetooth® function can be deactivated after initial device setup.

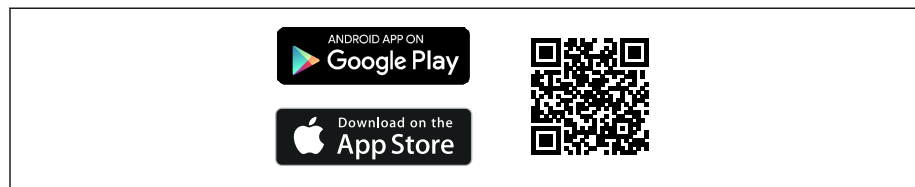

A0033202

9 QR code for free Endress+Hauser SmartBlue App

Download and installation:

1. Scan the QR code or enter **SmartBlue** in the search field of the Apple App Store (iOS) or Google Play Store (Android).
2. Install and start the SmartBlue app.
3. For Android devices: enable location tracking (GPS) (not required for iOS devices).
4. Select a device that is ready to receive from the device list displayed.

Login:

1. Enter the user name: admin
2. Enter the initial password: serial number of the device

3. Change the password after logging in for the first time

i **Information on password and reset code**

For devices that meet the requirements of IEC 62443-4-1 "Secure product development lifecycle management" ("ProtectBlue"):

- If the user-defined password is lost: refer to the user management instructions and the reset button in the operating manual.
- Refer to the associated Security Manual (SD).

For all other devices (without "ProtectBlue"):



- If the user-defined password is lost, access can be restored via a reset code. The reset code is the serial number of the device in reverse. The original password is once again valid after the reset code has been entered.
- The reset code can also be changed in addition to the password.
- If the user-defined reset code is lost, the password can no longer be reset via the SmartBlue app. Contact Endress+Hauser Service in this case.

7 System integration

Device description files	58
Measured variables via HART protocol	58

Device description files

Version data

Firmware version	01.00.zz	<ul style="list-style-type: none"> On the title page of the Operating instructions On the transmitter nameplate → <i>Transmitter nameplate</i>,  17 System → Information → Device → Firmware version
Release date of firmware version	04.2021	-
Manufacturer ID	0x11	Application → Communication → Information → Manufacturer ID
Device type code	0x71	Application → Communication → Information → Device ID
HART protocol revision	7	Application → Communication → Information → HART revision
Device revision	1	<ul style="list-style-type: none"> On the transmitter nameplate → <i>Transmitter nameplate</i>,  17 Diagnostics → Device information → Device revision

Operating tools

The suitable device description file for the individual operating tools is listed in the table below, along with information on where the file can be obtained.

IO-link	Sources for obtaining device descriptions
FieldCare	<ul style="list-style-type: none"> www.endress.com → Downloads USB stick (contact Endress+Hauser)
DeviceCare	<ul style="list-style-type: none"> www.endress.com → Downloads USB stick (contact Endress+Hauser)

Measured variables via HART protocol

 Technical data → *Protocol-specific data*,  91

Dynamic variables

The following measured variables (HART device variables) are assigned to the dynamic variables at the factory:



Primary dynamic variable (PV)	Volume flow
Secondary dynamic variable (SV)	Totalizer 1
Tertiary dynamic variable (TV)	Totalizer 2
Quaternary dynamic variable (QV)	Totalizer 3

The assignment can be configured in the **Output** submenu.

Navigation

Application → Communication → Output

- Assign PV
- Assign SV
- Assign TV
- Assign QV

 Assignment and available measured variables: Description of Device Parameters →  6

Device variables

The device variables are permanently assigned. A maximum of 8 device variables can be transmitted.



0	Volume flow
1	Mass flow
2	Conductivity
6	Electronic temperature
7	Totalizer 1
8	Totalizer 2
9	Totalizer 3

8 Commissioning

Post-installation check and post-connection check	62
IT security	62
Device-specific IT security	62
Switching on the device	63
Commissioning the device	64
Backing up or duplicating the device data	64

Post-installation check and post-connection check

Before commissioning the device, make sure that the post-installation and post-connection checks have been performed:

- Post-installation check → *Post-installation check*,  37
- Post-connection check → *Post-connection check*,  51

IT security

We only provide a warranty if the device is installed and used as described in the Operating Instructions. The device is equipped with security mechanisms to protect it against any inadvertent changes to the device settings.

IT security measures in line with operators' security standards and designed to provide additional protection for the device and device data transfer must be implemented by the operators themselves.

Device-specific IT security

Access via Bluetooth

Secure signal transmission via Bluetooth uses an encryption method tested by the Fraunhofer Institute.

- Without the SmartBlue App, the device is not visible via Bluetooth.
- Only one point-to-point connection is established between the device and a smartphone or tablet.

Access via the SmartBlue App

Two access levels (user roles) are defined for the device: the **Operator** user role and the **Maintenance** user role. The **Maintenance** user role is configured when the device leaves the factory.

If a user-specific access code is not defined (in the Enter access code parameter), the default setting **0000** continues to apply and the **Maintenance** user role is automatically enabled. The device's configuration data are not write-protected and can be edited at all times.

If a user-specific access code has been defined (in the Enter access code parameter), all the parameters are write-protected. The device is accessed with the **Operator** user role. When the user-specific access code is entered a second time, the **Maintenance** user role is enabled. All parameters can be written to.



For detailed information, see the "Description of Device Parameters" document pertaining to the device.

Protecting access via a password

There are a variety of ways to protect against write access to the device parameters:

- User-specific access code:
Protect write access to the device parameters via all the interfaces.
- Bluetooth key:
The password protects access and the connection between an operating unit, e.g. a smartphone or tablet, and the device via the Bluetooth interface.

General notes on the use of passwords

- The access code and Bluetooth key that are valid when the device is delivered must be redefined during commissioning.
- Follow the general rules for generating a secure password when defining and managing the access code and Bluetooth key.
- The user is responsible for the management and careful handling of the access code and Bluetooth key.



Write protection switch

The entire operating menu can be locked via the write protection switch. The values of the parameters cannot be changed. Write protection is disabled when the device leaves the factory.

Access authorization with write protection:

- Disabled: write access to the parameters
- Enabled: read-only access to the parameters

Write protection is enabled with the write protection switch on the back of the display module → *Hardware settings*,  50.



 The local display indicates that write protection is enabled on the top right of the display: .

Switching on the device

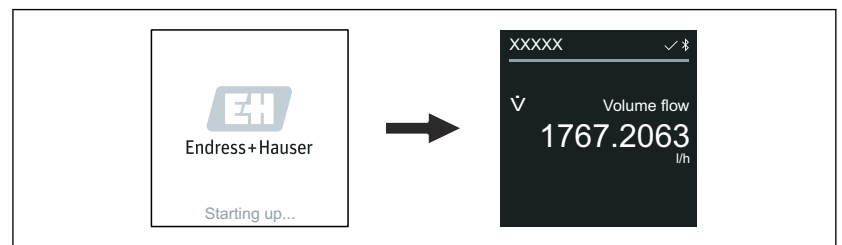
- ▶ Switch on the supply voltage for the device.
 - ↳ The local display switches from the start screen to the operational display.



A0042938

 If device startup is not successful, the device displays an error message to this effect → *Diagnostics and troubleshooting*,  70.

Commissioning the device

SmartBlue App

 Information on the SmartBlue App .

Connecting the SmartBlue App to the device

1. Enable Bluetooth on the mobile handheld terminal, tablet or smartphone.
2. Start the SmartBlue App.
 - ↳ A Live List shows all the devices available.
3. Select the desired device.
 - ↳ The SmartBlue App shows the device login.
4. Under user name, enter **admin**.
5. Under password, enter the device's serial number. Serial number:
 - *Transmitter nameplate*,  17.
6. Confirm your entries.
 - ↳ The SmartBlue App connects to the device and displays the main menu.

Backing up or duplicating the device data

The device does not have a memory module. However, using an operating tool based on the FDT technology (e.g. FieldCare) or the SmartBlue App, the following options are available:

- Save/recover configuration data
- Duplicate device configurations
- Transfer all relevant parameters when replacing electronic inserts

For more information → *Related documentation*,  6

9 Operation

Operational display	66
Reading off the device locking status	66
HistoROM data management	67

Operational display

During routine operation, the local display shows the operational display screen.

 The operational display can be customized: see the description of parameters .



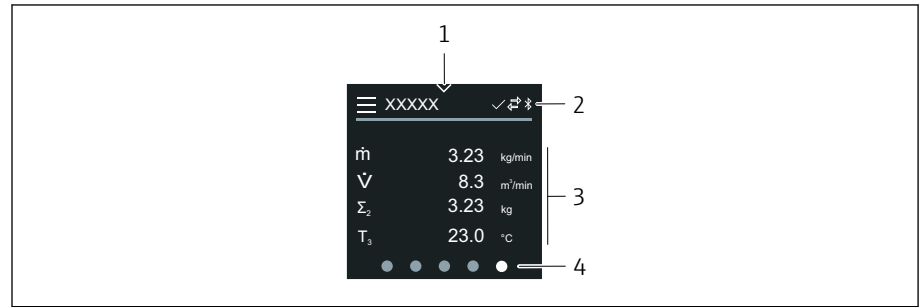





Operational display



A0042992

- 1 Quick access
- 2 Status symbols, communication symbols and diagnostic symbols
- 3 Measured values
- 4 Rotating page display

Symbols

-  Locking status
-  Bluetooth is active.
-  Device communication is enabled.
-  Status signal: function check
-  Status signal: maintenance required
-  Status signal: out of specification
-  Status signal: failure
-  Status signal: diagnostics active.

Reading off the device locking status

Indicates the write protection with the highest priority that is currently active.

Navigation

"System" menu → Device management → Locking status

Parameter overview with brief description

Parameter	Description	User interface
Locking status	Indicates the write protection with the highest priority that is currently active.	<ul style="list-style-type: none"> ▪ Hardware locked ▪ Temporarily locked option (e.g. during IO-Link block configuration or parameter upload)

HistoROM data management

The device features HistoROM data management. Device data and process data can be saved, imported and exported with the HistoROM data management function, making operation and servicing far more reliable, secure and efficient.

Data backup

Automatically

The most important device data, e.g. sensor and transmitter, are automatically saved in the S+T-DAT.

Following replacement of the sensor, the customer-specific sensor data are transferred to the device. The device goes into operation immediately without any problems.

Manual

The transmitter data (customer settings) must be manually saved.

Storage concept

	HistoROM backup	S+T-DAT
Available data	<ul style="list-style-type: none"> ▪ Event logbook, e.g. Diagnostic events ▪ Parameter data record backup 	<ul style="list-style-type: none"> ▪ Sensor data, e.g. Nominal diameter ▪ Serial number ▪ Calibration data ▪ Configuration of the device, e.g. software options
Storage location	On the sensor electronics module (ISEM)	In the sensor connector in the sensor neck

Data transmission

- A parameter configuration can be transferred to another device using the export function of the operating tool. The parameter configuration can be duplicated or saved in an archive.
- IO-Link engineering tools also provide an option for carrying out parameter configuration using an IO-Link master, allowing parameters to be saved and restored from there.

10 Diagnostics and troubleshooting

General troubleshooting	70
Diagnostic information via LED	71
Diagnostic information on local display	73
Diagnostic information in FieldCare or DeviceCare	74
Changing the diagnostic information	75
Overview of diagnostic information	75
Pending diagnostic events	78
Diagnostic list	78
Event logbook	78
Resetting the device	80

General troubleshooting

Local display

Fault	Possible causes	Remedy
Local display dark, no output signals	Supply voltage does not match the voltage specified on the nameplate. Supply voltage has incorrect polarity. Connector is not plugged in correctly. Electronics module is defective.	Apply the correct supply voltage. Reverse polarity of supply voltage. Check contact of cables. Check connector. Order the appropriate spare part.
Local display is dark, but signal output is within the valid range.	Incorrect contrast setting of local display. Cable connector for the local display is not correctly connected. Local display is defective.	Adjust the contrast of the local display to ambient conditions. Plug in the cable connector correctly. Order the appropriate spare part.
Display alternates between error message and operational display	Diagnostic event has occurred.	Carry out appropriate troubleshooting measures.
Local display shows text in a foreign, incomprehensible language.	A foreign language is set.	Set the language of the local display.

Only for remote version

Fault	Possible causes	Remedy
Local display displays a fault, no output signals	Cable connectors between the electronics module and local display are not plugged in correctly. Electrode cable and coil current cable are not plugged in correctly.	Plug in the cable connector correctly. Plug in the electrode cable and coil current cable correctly.

Output signal

Fault	Possible causes	Remedy
Local display shows the correct value, but signal output is incorrect, though in the valid range.	Parameter configuration error	<ul style="list-style-type: none"> ■ Check parameter configuration. ■ Correct parameter configuration.
Device is measuring incorrectly.	<ul style="list-style-type: none"> ■ Parameter configuration error ■ The device is being operated outside the application range. 	<ul style="list-style-type: none"> ■ Check parameter configuration. ■ Correct parameter configuration. ■ Observe limit values indicated.

Access and communication

Fault	Possible causes	Remedy
Not possible to write-access the parameter.	Write protection is enabled.	Set the write protection switch on the local display to the Off position.
	Current user role has limited access authorization.	<ol style="list-style-type: none"> 1. Check user role. 2. Enter correct customer-specific access code.
Device communication is not possible.	Data transfer is active.	Wait until the data transfer or the current action is finished.
SmartBlue App does not show the device in the live list.	<ul style="list-style-type: none"> Bluetooth is disabled on the device. Bluetooth is disabled on the smartphone or tablet. 	<ol style="list-style-type: none"> 1. Check whether the Bluetooth symbol appears on the local display. 2. Enable Bluetooth on the device. 3. Enable Bluetooth on the smartphone or tablet.
Device cannot be operated with the SmartBlue App.	<ul style="list-style-type: none"> Bluetooth connection is not available. The device is already connected to another smartphone or tablet. Incorrect password entered. Password forgotten. 	<ol style="list-style-type: none"> 1. Check whether other devices are connected to the SmartBlue App. 2. Disconnect any other device connected to the SmartBlue App. <ol style="list-style-type: none"> 1. Enter correct password. 2. Contact Endress+Hauser service organization.
Login with user data is not possible with the SmartBlue App.	Device in operation for the first time.	<ol style="list-style-type: none"> 1. Enter the initial password (serial number of the device). 2. Change the initial password.

Diagnostic information via LED

Only for devices with the order code for "Display; operation", option H

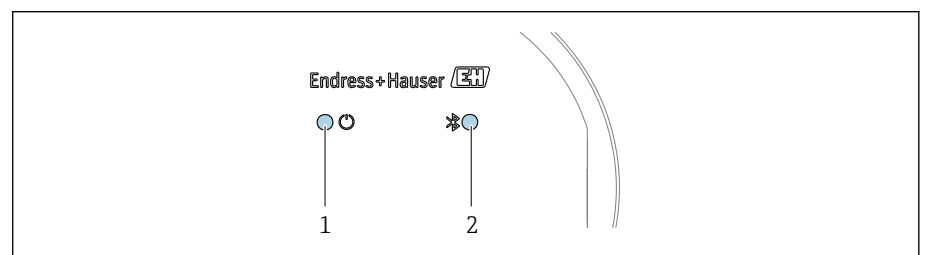

- 1 Device status
- 2 Bluetooth

A0044231

LED	Status	Meaning
1 Device status (normal operation)	Off	No power supply
	Permanently green	Device status is OK. No warning / failure / alarm
	Flashing red	Warning is active.
	Permanently red	Alarm is active.

LED	Status	Meaning
2 Bluetooth	Off Permanently blue Flashing blue	Bluetooth is disabled. Bluetooth is enabled. Data transfer in progress.

Diagnostic information on local display

Diagnostic message

The local display alternates between displaying faults as a diagnostic message and displaying the operational display screen.

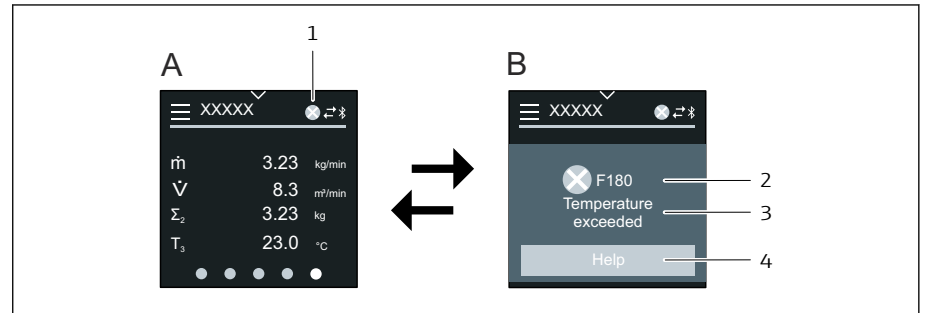

- A Operational display in alarm condition
- B Diagnostic message
- 1 Diagnostic behavior
- 2 Diagnostic behavior with diagnostic code
- 3 Short text
- 4 Open information on remedial measures (HART and Modbus RS485 only)

If two or more diagnostic events are pending simultaneously, the local display only shows the diagnostic message with the highest priority.

- i** Other diagnostic events that have occurred can be opened as follows:
 - Via FieldCare → *Operating tools*, 110
 - Via DeviceCare → *Operating tools*, 110
 - Via IO-Link

Status signals

The status signals provide information on the state and reliability of the device by categorizing the cause of the diagnostic information (diagnostic event).

- i** The status signals are categorized according to NAMUR Recommendation NE 107: F = Failure, C = Function Check, S = Out of Specification, M = Maintenance Required, N = No Effect



Failure

- A device error has occurred.
- Measured value is no longer valid.

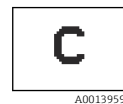

Function check

Device is in the service mode, e.g. during a simulation.

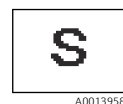

Out of specification

Device is being operated outside the technical specification limits, e.g. outside the process temperature range.



Maintenance required

- Maintenance is required.
- Measured value is still valid.

Diagnostic information

The fault can be identified using the diagnostic information. The short text displays a tip about the fault.

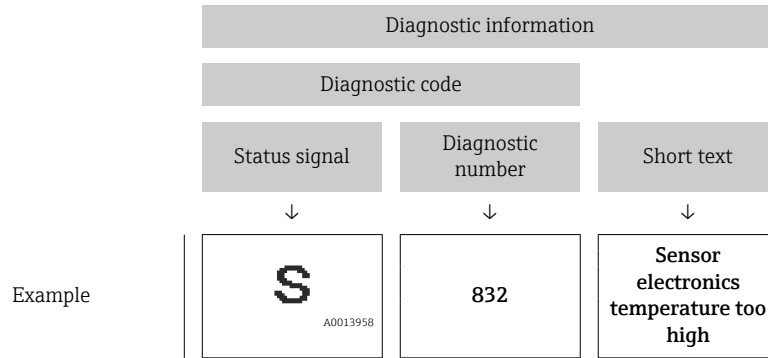

Diagnostic information in FieldCare or DeviceCare

Diagnostic options

After the connection has been established, the device shows faults on the home page.

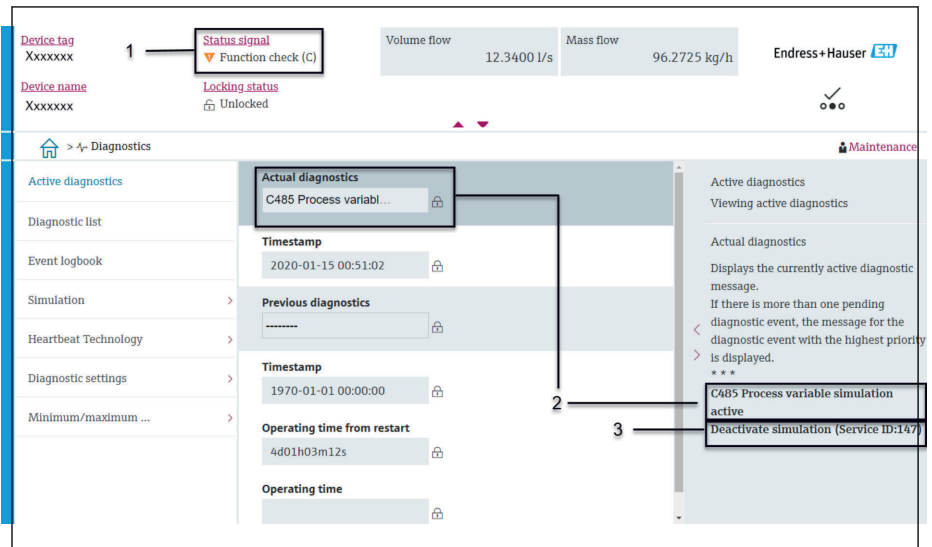

- 1 Status area with diagnostic behavior and status signal
- 2 Diagnostic code and short message
- 3 Troubleshooting measures with service ID

- i** Other diagnostic events that have occurred can be opened in the **Diagnostics** menu as follows:
 - Via parameter
 - Via submenus

Diagnostic information

The fault can be identified using the diagnostic information. The short text displays a tip about the fault. The corresponding symbol for the diagnostic behavior appears at the start.

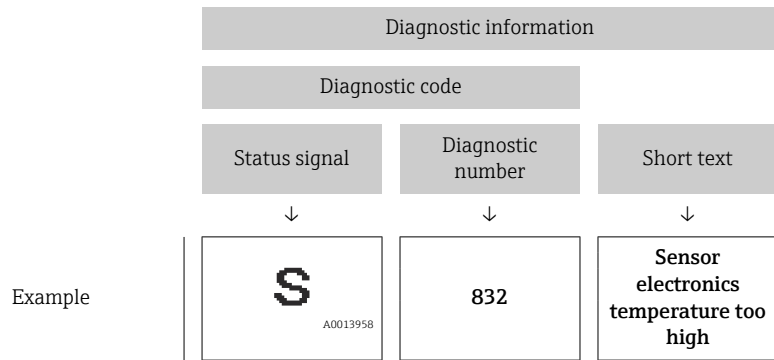

Changing the diagnostic information

Adapting the diagnostic behavior

Each item of diagnostic information is assigned a specific diagnostic behavior at the factory. The user can change the assignment for specific diagnostic information in the **Diagnostic settings** submenu.

Navigation path

Diagnostics → Diagnostic settings

You can assign the following options to the diagnostic number as the diagnostic behavior:

Options	Description
Alarm	<ul style="list-style-type: none"> Device stops measurement. Signal outputs and totalizers assume a defined alarm condition. Diagnostic message is generated.
Warning	<ul style="list-style-type: none"> Device continues measuring. Signal outputs and totalizers are not affected. Diagnostic message is generated.
Logbook entry only	<ul style="list-style-type: none"> Device continues measuring. The local display shows the diagnostic message in the Event logbook submenu (Event list submenu) and does not alternate with the operational display.
Off	<ul style="list-style-type: none"> Diagnostic event is ignored. Diagnostic message is not generated and not entered.

Overview of diagnostic information

i The amount of diagnostic information and the number of measured variables affected increase if the device has one or more application packages.

Diagnostic number	Short text	Remedy instructions	Status signal [from the factory]	Diagnostic behavior [from the factory]
Diagnostic of sensor				
043	Sensor 1 short circuit detected	1. Check sensor cable and sensor 2. Execute Heartbeat Verification 3. Replace sensor cable or sensor	S	Warning ¹⁾
082	Data storage inconsistent	Check module connections	F	Alarm
083	Memory content inconsistent	1. Restart device 2. Restore S-DAT data 3. Replace S-DAT	F	Alarm
168	Buildup limit exceeded	Clean measuring tube	M	Warning
169	Conductivity measurement failed	1. Check grounding conditions 2. Deactivate conductivity measurement	M	Warning
170	Coil resistance faulty	Check ambient and process temperature	F	Alarm
180	Temperature sensor defective	1. Check sensor connections 2. Replace sensor cable or sensor 3. Turn off temperature measurement	F	Warning
181	Sensor connection faulty	1. Check sensor cable and sensor 2. Execute Heartbeat Verification 3. Replace sensor cable or sensor	F	Alarm
Diagnostic of electronic				
201	Electronics faulty	1. Restart device 2. Replace electronics	F	Alarm
230	Date/time incorrect	1. Replace RTC buffer battery 2. Set date and time	M	Warning ¹⁾
231	Date/time not available	1. Replace display module or its cable 2. Set date and time	M	Warning ¹⁾
242	Firmware incompatible	1. Check firmware version 2. Flash or replace electronic module	F	Alarm
252	Module incompatible	1. Check electronic modules 2. Check if correct modules are available (e.g. NEx, Ex) 3. Replace electronic modules	F	Alarm
278	Display module defective	Replace display module	F	Alarm
283	Memory content inconsistent	Restart device	F	Alarm
302	Device verification active	Device verification in progress, please wait.	C	Warning ¹⁾
311	Sensor electronics (ISEM) faulty	Maintenance required! Do not reset device	M	Warning

Diagnostic number	Short text	Remedy instructions	Status signal [from the factory]	Diagnostic behavior [from the factory]
331	Firmware update failed in module 1 to n	1. Update firmware of device 2. Restart device	F	Warning
372	Sensor electronics (ISEM) faulty	1. Restart device 2. Check if failure recurs 3. Replace sensor electronic module (ISEM)	F	Alarm
373	Sensor electronics (ISEM) faulty	Contact service	F	Alarm
376	Sensor electronics (ISEM) faulty	1. Replace sensor electronic module (ISEM) 2. Turn off diagnostic message	S	Warning ¹⁾
377	Electrode signal faulty	1. Activate empty pipe detection 2. Check partial filled pipe and installation direction 3. Check sensor cabling 4. Deactivate diagnostics 377	S	Warning ¹⁾
378	Electronic module supply voltage faulty	1. Restart device 2. Check if failure recurs 3. Replace electronic module	F	Alarm
383	Memory content	Reset device	F	Alarm
387	HistoROM data faulty	Contact service organization	F	Alarm
Diagnostic of configuration				
410	Data transfer failed	1. Retry data transfer 2. Check connection	F	Alarm
412	Processing download	Download active, please wait	C	Warning
419	Power cycle required	Power cycle device	F	Alarm
437	Configuration incompatible	1. Update firmware 2. Execute factory reset	F	Alarm
438	Dataset different	1. Check dataset file 2. Check device parameterization 3. Download new device parameterization	M	Warning
453	Flow override active	Deactivate flow override	C	Warning
484	Failure mode simulation active	Deactivate simulation	C	Alarm
485	Process variable simulation active	Deactivate simulation	C	Warning
495	Diagnostic event simulation active	Deactivate simulation	C	Warning
511	Electronic module settings faulty	1. Check measuring period and integration time 2. Check sensor properties	C	Alarm
Diagnostic of process				
832	Sensor electronics temperature too high	Reduce ambient temperature	S	Warning ¹⁾
833	Sensor electronics temperature too low	Increase ambient temperature	S	Warning ¹⁾

Diagnostic number	Short text	Remedy instructions	Status signal [from the factory]	Diagnostic behavior [from the factory]
834	Process temperature too high	Reduce process temperature	S	Warning ¹⁾
835	Process temperature too low	Increase process temperature	S	Warning ¹⁾
842	Process value below limit	Low flow cut off active! Check low flow cut off configuration	S	Warning ¹⁾
937	Sensor symmetry	1. Eliminate external magnetic field near sensor 2. Turn off diagnostic message	S	Warning ¹⁾
938	Coil current not stable	1. Check if external magnetic interference is present 2. Perform Heartbeat Verification 3. Check flow value	F	Alarm ¹⁾
944	Monitoring failed	Check process conditions for Heartbeat Monitoring	S	Warning
961	Electrode potential out of specification	1. Check process conditions 2. Check ambient conditions	S	Warning ¹⁾
962	Pipe empty	1. Perform full pipe adjustment 2. Perform empty pipe adjustment 3. Turn off empty pipe detection	S	Warning ¹⁾

1) Diagnostic behavior can be changed.

Pending diagnostic events

The **Active diagnostics** submenu displays the current diagnostic event and the last diagnostic event to occur.

Diagnostics → Active diagnostics



The **Diagnostic list** submenu shows other diagnostic events that are pending.

Diagnostic list

The **Diagnostic list** submenu shows up to 5 currently pending diagnostic events with the related diagnostic information. If more than 5 diagnostic events are pending, the local display shows the diagnostic information with the highest priority.

Navigation path

Diagnostics → Diagnostic list

Event logbook

Reading out the event logbook



The event logbook is only available via FieldCare, DeviceCare or SmartBlue App (Bluetooth).



The **Event logbook** submenu shows a chronological overview of the event messages that have occurred.

Navigation path

Diagnostics menu → **Event logbook** submenu

Chronological display with a maximum of 20 event messages.

The event history includes the following entries:

- Diagnostic event → *Overview of diagnostic information*,  75
- Information event → *Overview of information events*,  79

In addition to the operation time of the event occurrence, each event is also assigned a symbol that indicates whether the event has occurred or has ended:

- Diagnostic event
 - ☹: Occurrence of the event
 - ☺: End of the event
- Information event
 - ☹: Occurrence of the event



Filter event messages:

Filtering the event logbook

The **Event logbook** submenu displays the category of event messages that were configured with the **Filter options** parameter.

Navigation path

Diagnostics → Event logbook → Filter options

Filter categories

- All
- Failure (F)
- Function check (C)
- Out of specification (S)
- Maintenance required (M)
- Information (I)

Overview of information events

The information event is only displayed in the event logbook.



See also information in the IODD finder

→ <https://ioddfinder.io-link.com/>,  109.

Info number	Info name
I1000	----- (Device ok)
I1079	Sensor changed
I1089	Power on
I1090	Configuration reset
I1091	Configuration changed
I11036	Date/time set successfully
I11167	Date/time resynchronized
I1137	Display module replaced
I1151	History reset
I1155	Sensor electronics temperature reset
I1157	Memory error event list
I1256	Display: access status changed

Info number	Info name
I1335	Firmware changed
I1351	Empty pipe detection adjustment failure
I1353	Empty pipe detection adjustment ok
I1397	Fieldbus: access status changed
I1398	CDI: access status changed
I1443	Buildup thickness not determined
I1444	Device verification passed
I1445	Device verification failed
I1459	I/O module verification failed
I1461	Sensor verification failed
I1462	Sensor electronic module verific. failed
I1512	Download started
I1513	Download finished
I1514	Upload started
I1515	Upload finished
I1622	Calibration changed
I1624	All totalizers reset
I1625	Write protection activated
I1626	Write protection deactivated
I1629	CDI: login successful
I1632	Display: login failed
I1633	CDI: login failed
I1634	Reset to factory settings
I1635	Reset to delivery settings
I1649	Hardware write protection activated
I1650	Hardware write protection deactivated
I1712	New flash file received
I1725	Sensor electronic module (ISEM) changed

Resetting the device

The entire configuration, or a part of the configuration, can be reset to a defined state here.

Navigation path

System → Device management → Device reset

Options	Description
To delivery settings	Every parameter for which a customer-specific default setting was ordered is reset to the customer-specific value. All other parameters are reset to the factory setting.
Restart device	The restart resets every parameter with data stored in volatile memory (RAM) to the factory setting (e.g. measured value data). The device configuration remains unchanged.
Restore S-DAT backup	Restores the data that is saved on the S-DAT. Additional information: This function can be used to resolve the memory issue "083 Memory content inconsistent" or to restore the S-DAT data when a new S-DAT has been installed. Visibility depends on order options or device settings
Create T-DAT backup	Creates T-DAT backup.

Restore T-DAT backup	Restores the data saved on the T-DAT. This function can be used to resolve the memory issue "283 Memory content inconsistent" or to restore the T-DAT data when a new T-DAT has been installed. Visibility depends on order options or device settings
(Back to box) ¹⁾	Similar to the reset To delivery settings option, the IO-Link connection is also disconnected. Consequently any existing DataStorage Backup in the master is not overwritten. Device is waiting for power cycle.

1) Available as IO-Link system command

11 Maintenance

Maintenance tasks	84
Services	84

Maintenance tasks

The device is maintenance-free. Modifications or repairs may only be carried out following consultation with an Endress+Hauser service organization. It is recommended to examine the device regularly for corrosion, mechanical wear and damage.

Cleaning

Cleaning of surfaces not in contact with the medium

1. Recommendation: Use a lint-free cloth that is either dry or slightly dampened using water.
2. Do not use sharp objects or aggressive cleaning agents that could damage surfaces (e.g. displays, housing) and seals.
3. Do not use high-pressure steam.
4. Ensure compliance with the protection class of the device.

NOTICE

Cleaning agents can damage the surfaces!

Incorrect cleaning agents can damage the surfaces!

- ▶ Do not use cleaning agents containing concentrated mineral acids, alkalis or organic solvents e.g. benzyl alcohol, methylene chloride, xylene, concentrated glycerol cleaners or acetone.

Cleaning of surfaces in contact with the medium

Note the following for cleaning and sterilization in place (CIP/SIP):

- Use only cleaning agents to which the materials in contact with the medium are sufficiently resistant.
- Observe the permitted maximum medium temperature.

Services

Endress+Hauser offers a wide range of services for device maintenance, e.g. recalibration, maintenance service or device tests.

Endress+Hauser sales organizations can provide information about the services available.

12 Disposal

Removing the device	86
Disposing of the device	86

Removing the device

1. Disconnect the device from the supply voltage.
2. Remove all connecting cables.

⚠ WARNING

Process conditions can put staff at risk!

- ▶ Wear suitable protective equipment.
- ▶ Allow the device and pipe to cool.
- ▶ Empty the device and pipe so that they are unpressurized.
- ▶ Rinse the device and pipe if necessary.

3. Remove the device correctly.

Disposing of the device

⚠ WARNING

Dangerous media can endanger staff and the environment!

- ▶ Ensure that the device and all cavities are free of medium residues that are hazardous to health or the environment, e.g. substances that have permeated into crevices or diffused through plastic.



A0042336

If required by the Directive 2012/19/EU of the European Parliament and the Council of 4 July 2012 on waste electrical and electronic equipment (WEEE), the device is marked with the depicted symbol in order to minimize the disposal of WEEE as unsorted municipal waste.

- Do not dispose of devices bearing this marking as unsorted municipal waste. Instead, return them to Endress+Hauser for disposal under the applicable conditions.
- Observe applicable federal/national regulations.
- Ensure proper separation and reuse of the device components.
- Overview of installed materials: → *Materials*, 107

13 Technical data

Input	88
Output	90
Power supply	92
Cable specifications	93
Performance characteristics	95
Environment	97
Process	99
Mechanical construction	105
Local display	109
Certificates and approvals	110
Application packages	112

Input

Measured variable

Direct measured variables	<ul style="list-style-type: none"> ■ Volume flow (proportional to induced voltage) ■ Conductivity (order code for "Sensor option", option CX)
Calculated measured variables	Mass flow

Operable flow range

Over 1000 : 1

Measuring range

Typically $v = 0.01$ to 10 m/s (0.03 to 33 ft/s) with specified measuring accuracy

Electrical conductivity:

- ≥ 5 $\mu\text{S/cm}$ for liquids in general
- ≥ 20 $\mu\text{S/cm}$ for demineralized water

Flow characteristic values in SI units: DN 15 to 125 (½ to 4")

Nominal diameter		Recommended flow min./max. full scale value ($v \sim 0.3/10$ m/s)	Full scale value current output ($v \sim 2.5$ m/s)	Factory settings	
[mm]	[in]			Pulse value (~ 2 pulse/s)	Low flow cut off ($v \sim 0.04$ m/s)
		[dm³/min]	[dm³/min]	[dm³]	[dm³/min]
15	½	4 to 100	25	0.2	0.5
25	1	9 to 300	75	0.5	1
32	–	15 to 500	125	1	2
40	1 ½	25 to 700	200	1.5	3
50	2	35 to 1100	300	2.5	5
65	–	60 to 2000	500	5	8
80	3	90 to 3000	750	5	12
100	4	145 to 4700	1200	10	20
125	–	220 to 7500	1850	15	30

Flow characteristic values in SI units: DN 150 to 600 (6 to 24")

Nominal diameter		Recommended flow min./max. full scale value ($v \sim 0.3/10$ m/s)	Full scale value current output ($v \sim 2.5$ m/s)	Factory settings	
[mm]	[in]			Pulse value (~ 2 pulse/s)	Low flow cut off ($v \sim 0.04$ m/s)
		[m³/h]	[m³/h]	[m³]	[m³/h]
150	6	20 to 600	150	0.03	2.5
200	8	35 to 1100	300	0.05	5
250	10	55 to 1700	500	0.05	7.5
300	12	80 to 2400	750	0.1	10
350	14	110 to 3300	1000	0.1	15
400	16	140 to 4200	1200	0.15	20

Nominal diameter		Recommended flow min./max. full scale value (v ~ 0.3/10 m/s)	Full scale value current output (v ~ 2.5 m/s)	Factory settings	
[mm]	[in]			Pulse value (~ 2 pulse/s)	Low flow cut off (v ~ 0.04 m/s)
		[m ³ /h]	[m ³ /h]	[m ³]	[m ³ /h]
450	18	180 to 5 400	1 500	0.25	25
500	20	220 to 6 600	2 000	0.25	30
600	24	310 to 9 600	2 500	0.3	40

Flow characteristic values in US units: ½ - 24" (DN 15 - 600)

Nominal diameter		Recommended flow min./max. full scale value (v ~ 0.3/10 m/s)	Full scale value current output (v ~ 2.5 m/s)	Factory settings	
[in]	[mm]			Pulse value (~ 2 pulse/s)	Low flow cut off (v ~ 0.04 m/s)
		[gal/min]	[gal/min]	[gal]	[gal/min]
½	15	1.0 to 27	6	0.1	0.15
1	25	2.5 to 80	18	0.2	0.25
1 ½	40	7 to 190	50	0.5	0.75
2	50	10 to 300	75	0.5	1.25
3	80	24 to 800	200	2	2.5
4	100	40 to 1 250	300	2	4
6	150	90 to 2 650	600	5	12
8	200	155 to 4 850	1 200	10	15
10	250	250 to 7 500	1 500	15	30
12	300	350 to 10 600	2 400	25	45
14	350	500 to 15 000	3 600	30	60
16	400	600 to 19 000	4 800	50	60
18	450	800 to 24 000	6 000	50	90
20	500	1 000 to 30 000	7 500	75	120
24	600	1 400 to 44 000	10 500	100	180

Output

Output signal

Output versions

Order code 020: output; input	Output version
Option F	IO-Link

IO-Link

Physical interface	Similar to the standard IEC 61131-9
Signal	Digital communication signal IO-Link, 3-wire
IO-Link version	1.1
IO-Link SSP version	Smart Sensor Profile 2nd Edition V1.2
IO-Link device port	IO-Link port class A

Signal on alarm

Output behavior in the event of a device alarm (failure mode)

IO-Link

Operating mode	Digital transmission of all failure information
Device status	Readable via cyclic and acyclic data transmission

Low flow cut off

The switch points for low flow cut off are user-selectable.

Galvanic isolation

The outputs are galvanically isolated from one another and from earth.

Protocol-specific data

IO-Link specification	Version 1.1.3
Device ID	9728257
Manufacturer ID	17
Smart Sensor Profile	Smart Sensor Profile 2nd Edition V1.2; supported <ul style="list-style-type: none"> ■ Identification and Diagnosis ■ Digital Measuring and Switching Sensor (as per SSP type 4.3.4) ■ Function Class Sensor Control Wide
Smart Sensor Profile Type	Measuring profile type 4.3.4 Measuring and Switching Sensor, floating point, 4 channel
SIO mode	No
Speed	COM2 (38.4 kBaud)
Minimum cycle time	12 ms
Process data width	Input: 18 bytes (as per SSP 4.3.4) Output: 2 bytes (as per SSP 4.3.4)
OnRequestdata	8 bytes
Data storage	Yes
Block configuration	Yes
Device operational	The device is operational 6 s after the supply voltage has been applied
System integration	Cyclic input measured variables: <ul style="list-style-type: none"> ■ Volume flow [m³/h] ■ Conductivity [S/m], depending on order options or device settings ■ Temperature [°C], depending on the sensor option selected ■ Totalizer 1 [m³] Cyclic output measured variables: <ul style="list-style-type: none"> ■ Totalizer submenu – Totalize option ■ Totalizer submenu – Reset + hold option ■ Totalizer submenu – Reset + totalize option ■ Totalizer submenu – Hold option ■ Flow override ■ Device search

Device description

In order to integrate field devices into a digital communication system, the IO-Link system needs a description of the device parameters, such as output data, input data, data format, data volume and supported transmission rate.

These data are available in the device description (IODD) which is provided to the IO-Link Master when the communication system is commissioned.

The IODD can be downloaded as follows:

- www.endress.com
- <https://ioddfinder.io-link.com>

Power supply

Supply voltage

Order code for "Power supply"	Terminal voltage	Frequency range
Option A IO-Link port class A	DC 18 to 30 V ¹⁾	–

1) These values are absolute minimum and maximum values. No tolerance applies. The DC power unit must be tested to ensure it meets technical safety requirements (e.g. PELV, SELV) with limited power sources (e.g. Class 2).

Power consumption

- Transmitter:
IO-Link: Max. 6 W (active power)
- Switch-on current:
IO-Link: Max. 400 mA

Current consumption

Max 200 mA. (18 to 30 V, IO-Link port class A)

Power supply failure

- Totalizers stop at the last value measured.
- Device configuration remains unchanged.
- Error messages (incl. total operated hours) are stored.

Cable entries

M12 plug-in connector

Overvoltage protection

Mains voltage fluctuations	→ <i>Supply voltage</i> , 92
Overvoltage category	Overvoltage category II
Short-term, temporary overvoltage	Between cable and neutral conductor up to 1200 V for max. 5s
Long-term, temporary overvoltage	Up to 500 V between cable and ground

Cable specifications

Requirements for connecting cable

Electrical safety

As per applicable national regulations.

Permitted temperature range

- Observe the installation guidelines that apply in the country of installation.
- The cables must be suitable for the minimum temperatures and maximum temperatures to be expected.

Power supply cable (incl. conductor for the inner ground terminal)

- A standard installation cable is sufficient.
- Provide grounding according to applicable national codes and regulations.

Signal cable

IO-Link:

Twisted three- or four-core cable M12 A-coded according to IEC 61076-2-101 recommended with

- Conductor cross-section: 0.34 mm² (AWG22)
- Max. cable length: 20 m

Ground cable requirements

Copper wire: at least 6 mm² (0.0093 in²)

Connecting cable requirements



Connecting cable only necessary for remote version.

Electrode cable	Coil current cable
<p style="text-align: right; font-size: small;">A0054679</p> <p>1 GND (green): Ground-wire 0.38 mm² (AWG 21)</p> <p>2 E1 (brown): "Electrode E1" - core 0.38 mm² (AWG 21)</p> <p>3 E (yellow): grounding 0.38 mm² (AWG 21)</p> <p>4 E2 (white): "Electrode E2" - core 0.38 mm² (AWG 21)</p> <p>a Outer jacket</p> <p>b Cable shield</p> <p>c Core jacket</p> <p>d Core shield</p> <p>e Core insulation</p> <p>f Core</p>	<p style="text-align: right; font-size: small;">A0054680</p> <p>1 ER+ (black): coil current core 0.75 mm² (AWG 18)</p> <p>2 ER- (black): coil current core 0.75 mm² (AWG 18)</p> <p>3 NC (yellow-green): not connected 0.75 mm² (AWG 18)</p> <p>a Outer jacket</p> <p>b Cable shield</p> <p>c Core insulation</p> <p>d Core</p> <p>e Core reinforcement</p>



Armored connecting cable

Armored connecting cables with additional, metal reinforcing braid can be ordered from Endress+Hauser. Armored connecting cables are used:

- When laying the cable directly in the ground
- Where there is a risk of damage from rodents
- If using the device below IP68 degree of protection

Electrode cable

Design	3×0.38 mm ² (21 AWG) with common, braided copper shield (∅ ~ 9.5 mm (0.37 in)) and individual shielded cores If using the empty pipe detection (EPD) function: 4×0.38 mm ² (21 AWG) with common, braided copper shield (∅ ~ 9.5 mm (0.37 in)) and individual shielded cores
Conductor resistance	≤ 50 Ω/km (0.015 Ω/ft)
Capacitance: core/shield	≤ 420 pF/m (128 pF/ft)
Cable length	Depends on the medium conductivity: maximum 200 m (656 ft)
Cable lengths (available for order)	5 m (15 ft), 10 m (30 ft), 20 m (60 ft) Armored cables: variable length up to maximum 200 m (656 ft)
Operating temperature	-20 to +80 °C (-4 to +176 °F)

Coil current cable

Design	3×0.75 mm ² (18 AWG) with common, braided copper shield (∅ ~ 9.5 mm (0.37 in)) and individual shielded cores
Conductor resistance	≤ 37 Ω/km (0.011 Ω/ft)
Capacitance: core/shield	≤ 120 pF/m (37 pF/ft)
Cable length	Depends on the medium conductivity, max. 200 m (656 ft)

Cable lengths (available for order)	5 m (15 ft), 10 m (30 ft), 20 m (60 ft) or variable length up to max. 200 m (656 ft) Armored cables: variable length up to max. 200 m (656 ft)
Operating temperature	-20 to +80 °C (-4 to +176 °F)
Test voltage for cable insulation	≤ AC 1 433 V rms 50/60 Hz or ≥ DC 2 026 V

Performance characteristics

Reference operating conditions

- Error limits based on ISO 20456:2017
- Water, typically: +15 to +45 °C (+59 to +113 °F); 0.5 to 7 bar (73 to 101 psi)
- Data as indicated in the calibration protocol
- Accuracy based on accredited calibration rigs according to ISO 17025

i To obtain measured errors, use the *Applicator* sizing tool → *Service-specific accessory*, 147

Maximum measurement error

o. r. = of reading

Maximum permissible error under reference operating conditions

Volume flow

- ±0.5 % o. r. ±1 mm/s (±0.04 in/s)
- Optional: ±0.2 % o.r. ± 2 mm/s (0.08 in/s)

i Fluctuations in the supply voltage have no effect within the specified range.

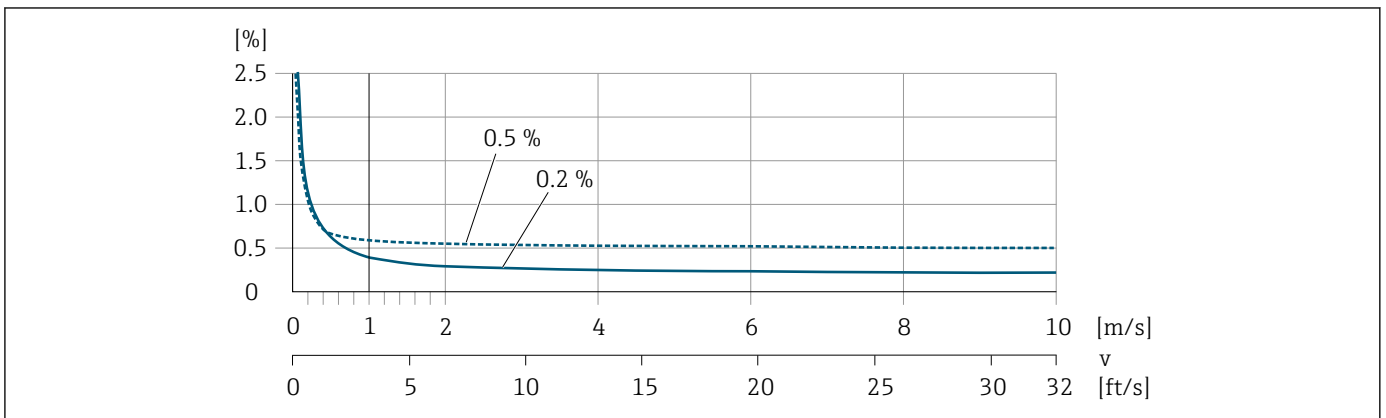

10 Maximum measurement error in % o.r.

A0028974

Electrical conductivity

Order code for "Conductivity measurement", option CX

The values apply for:

- Measurements at a reference temperature of +25 °C (+77 °F).
If the temperature differs, the temperature coefficient of the medium must be taken into account (typically 2.1%/K).
- Device version: compact (transmitter and sensor form a mechanical unit)
- Devices in a metal pipe or in a non-metal pipe with installed ground disks.
- Devices whose potential equalization has been established according to the specifications in the related Operating Instructions.

Conductivity [$\mu\text{S}/\text{cm}$]	Measurement error [%] o. r.
5 to 20	$\pm 20\%$
20 to 20000	$\pm 10\%$
20000 to 100000	$\pm 20\%$

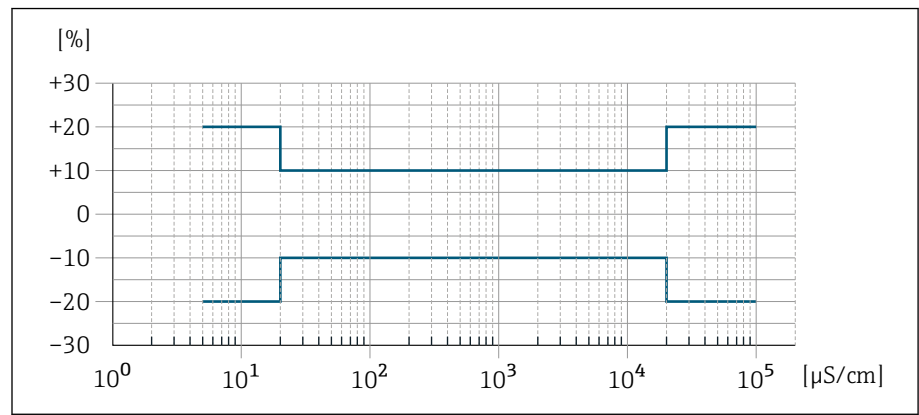

A0042279

11 Measurement error for order code "Conductivity measurement", option CX

Repeatability

Volume flow	Max. $\pm 0.1\%$ o. r. ± 0.5 mm/s (0.02 in/s)
Electrical conductivity	Max. $\pm 5\%$ o. r. (5 to 100000 $\mu\text{S}/\text{cm}$)

Environment

Ambient temperature range

Transmitter	-40 to +60 °C (-40 to +140 °F)
Local display	-20 to +60 °C (-4 to +140 °F) The readability of the display may be impaired at temperatures outside the temperature range.
Sensor	Process connection, carbon steel: -10 to +60 °C (+14 to +140 °F) Process connection, stainless steel: -40 to +60 °C (-40 to +140 °F)
Liner	Do not exceed or fall below the permitted temperature range of the liner → <i>Medium temperature range</i> , ☰ 99.



Dependency of ambient temperature on medium temperature → *Medium temperature range*, ☰ 99



If using the device in hazardous areas, observe the "Safety Instructions" documentation.

Storage temperature

The storage temperature corresponds to the ambient temperature range of the transmitter and sensor.

Relative humidity

The device is suitable for use in outdoor and indoor areas with a relative humidity of 5 to 95%.

Operating height

According to EN 61010-1

- Without overvoltage protection: ≤ 2 000 m
- With overvoltage protection: > 2 000 m (e.g. Endress+Hauser HAW series)

Degree of protection

Transmitter	<ul style="list-style-type: none"> ▪ IP66/67, Type 4X enclosure, suitable for pollution degree 4 ▪ Open housing: IP20, Type 1 enclosure, suitable for pollution degree 2 	
Sensor	IP66/67, Type 4X enclosure, suitable for pollution degree 4	
Optional sensor		
Order code for "Sensor option", option CQ	IP68, type 6P, factory encapsulation Sensor with aluminum half-shell housing	Use of device under rainwater or surface water at a maximum water depth of: 3 m (10 ft)

Vibration resistance and shock resistance

Compact version

Vibration, sinusoidal Following IEC 60068-2-6	2 to 8.4 Hz	3.5 mm peak
	8.4 to 2 000 Hz	1 g peak

Vibration, broad-band random Following IEC 60068-2-64	10 to 200 Hz	0.003 g ² /Hz
	200 to 2 000 Hz	0.001 g ² /Hz (1.54 g rms)
Shocks, half-sine Following IEC 60068-2-27	6 ms 30 g	

Shock

Due to rough handling similar to IEC 60068-2-31.

Remote version (sensor)

Vibration, sinusoidal Following IEC 60068-2-6	2 to 8.4 Hz	7.5 mm peak
	8.4 to 2 000 Hz	2 g peak
Vibration, broad-band random Following IEC 60068-2-6	10 to 200 Hz	0.01 g ² /Hz
	200 to 2 000 Hz	0.003 g ² /Hz (2.7 g rms)
Shocks, half-sine Following IEC 60068-2-6	6 ms 50 g	

Shock

Due to rough handling similar to IEC 60068-2-31.

Electromagnetic compatibility (EMC)

As per IEC/EN 61326 and IO-Link Interface and System Specification



For more information: Declaration of Conformity

Process

Medium temperature range

The medium temperature range depends on the liner.

PFA, DN 25 to 200 (1 to 8")

-20 to +150 °C (-4 to +302 °F)

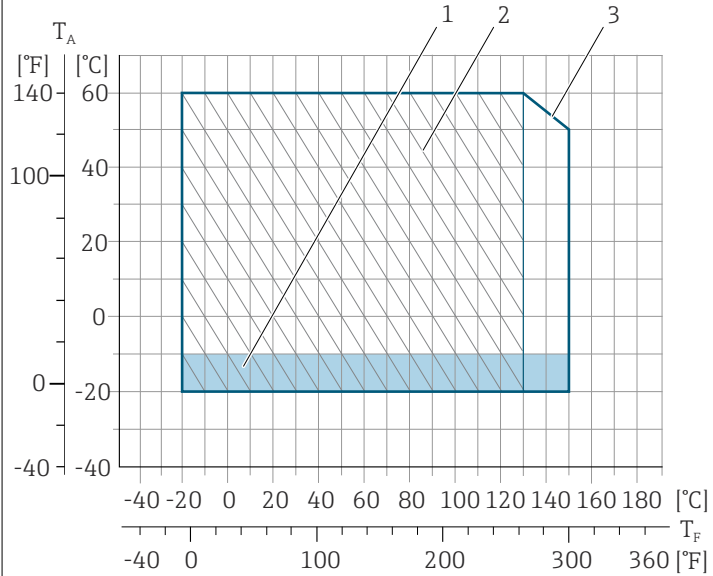

A0043553

T_A Ambient temperature

T_F Medium temperature

- 1 Colored area: the ambient temperature range -10 to -20 °C (+14 to -4 °F) applies to stainless flanges only
- 2 Hatched area: harsh environment only for medium temperature range -20 to +130 °C (-4 to +266 °F)
- 3 -20 to +150 °C (-4 to +302 °F)

PTFE

- -20 to +110 °C (-4 to +230 °F) (order code for "Liner", option 8)
- -40 to +130 °C (-40 to +266 °F) (order code for "Liner", option E)

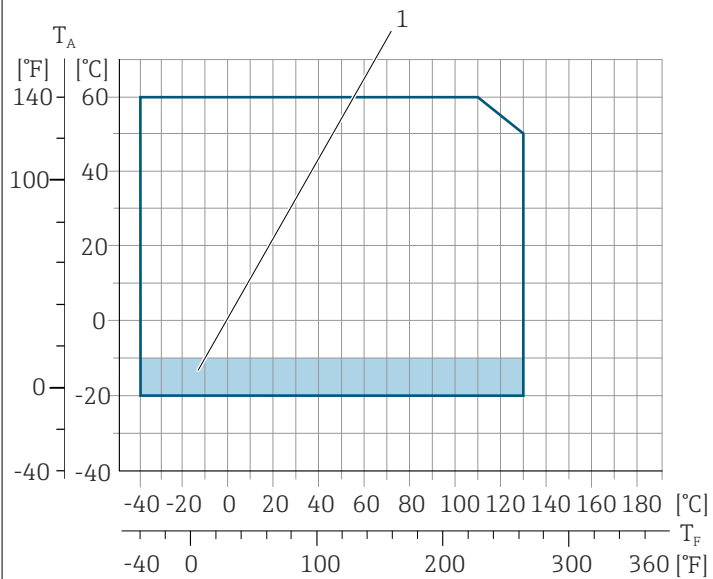

A0043555

T_A Ambient temperature

T_F Medium temperature

- 1 Colored area: the ambient temperature range of -10 to -20 °C (+14 to -4 °F) applies to stainless flanges only

Conductivity

The minimum conductivity is:

- 5 $\mu\text{S/cm}$ for liquids in general
- 20 $\mu\text{S/cm}$ for demineralized water

The following basic conditions must be observed for $< 20 \mu\text{S/cm}$:

- Order code 013 for "Functionality", option D "Extended transmitter" and higher output signal damping is recommended for values under $20 \mu\text{S/cm}$.
- Observe the maximum permitted cable length L_{max} . This length is determined by the conductivity of the medium.
- With order code 013 "Functionality", option A "Standard transmitter" and empty pipe detection (EPD) switched on, the minimum conductivity is $20 \mu\text{S/cm}$.
- With order code 013 "Functionality", option A "Standard transmitter" - remote version, empty pipe detection may not be activated if $L_{\text{max}} > 20 \text{ m}$.

i Note that in the case of the remote version, the minimum conductivity depends on the cable length.

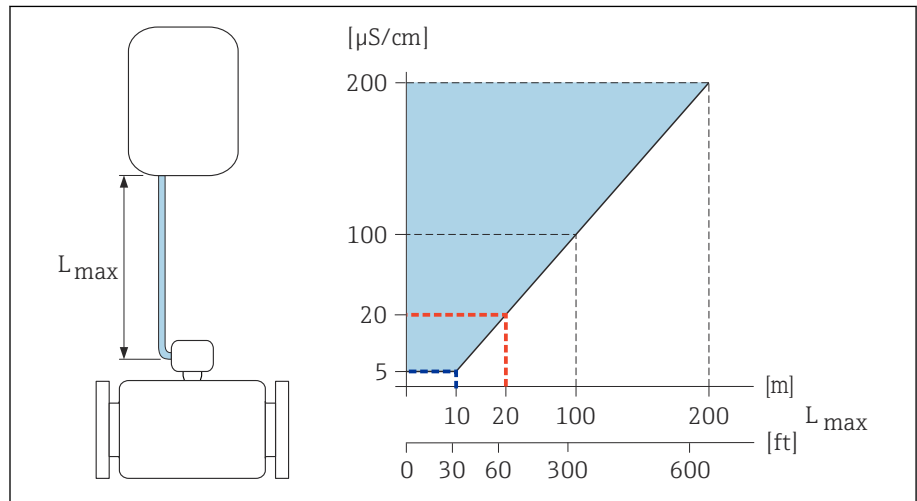

12 Permitted length of connecting cable

Colored area = permitted range

L_{max} = length of connecting cable in [m] ([ft])

[$\mu\text{S/cm}$] = medium conductivity

Red line = order code 013 "Functionality", option A "Standard transmitter"

Blue line = order code 013 "Functionality", option D "Extended transmitter"

Flow limit

Pipe diameter and flow rate determine the nominal diameter of the sensor.

i The flow velocity is increased by reducing the sensor nominal diameter.

2 to 3 m/s (6.56 to 9.84 ft/s)	Optimum flow velocity
$v < 2 \text{ m/s}$ (6.56 ft/s)	For abrasive media, e.g. potter's clay, lime milk, ore slurry
$v > 2 \text{ m/s}$ (6.56 ft/s)	For media producing buildup, e.g. wastewater sludge

Pressure/temperature ratings

Maximum permitted medium pressure as a function of the medium temperature.

The data relate to all pressure-bearing parts of the device.

Fixed flange similar to EN 1092-1

Stainless steel (-20 °C (-4 °F))
Carbon steel (-10 °C (14 °F))

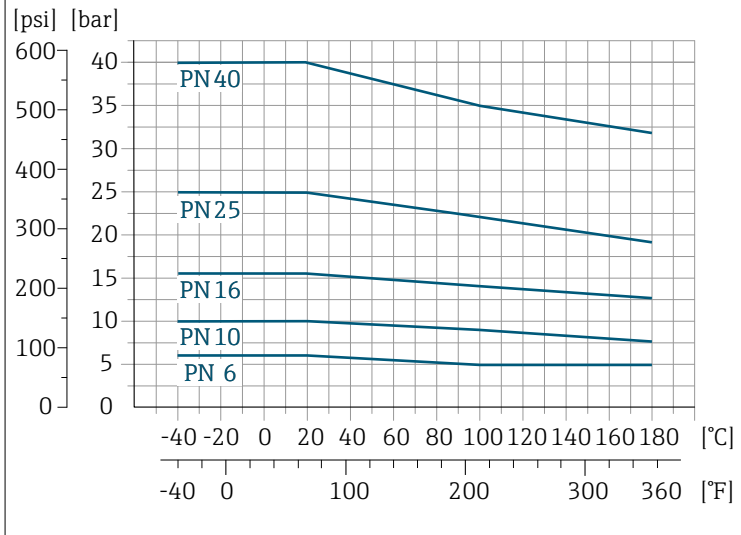

A0029391-EN

Fixed flange similar to ASME B16.5

Stainless steel

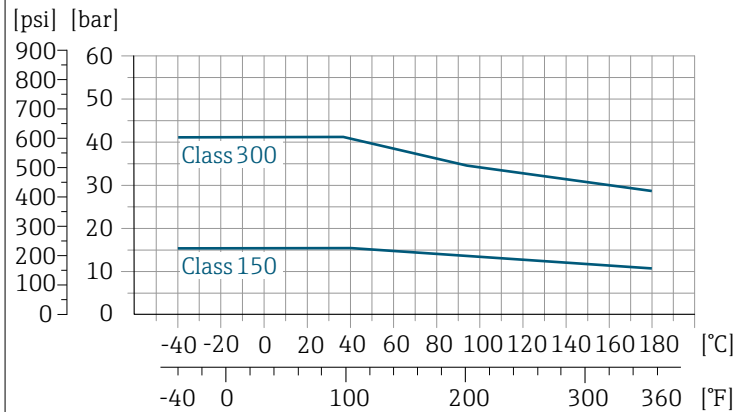

A0029394-EN

Carbon steel

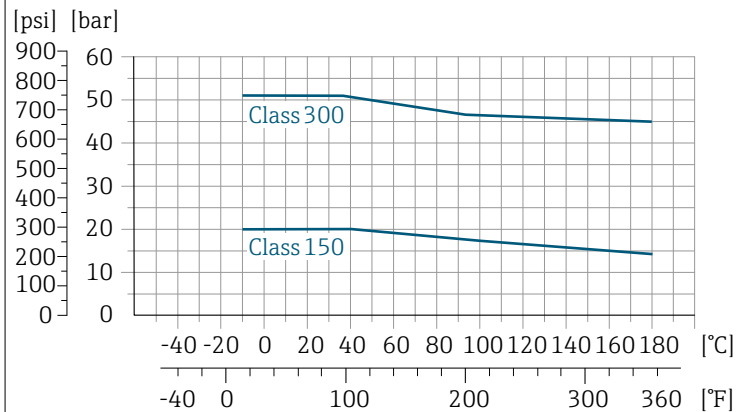

A0029393-EN

Fixed flange similar to JIS B2220

Stainless steel (-20 °C (-4 °F))
Carbon steel (-10 °C (14 °F))

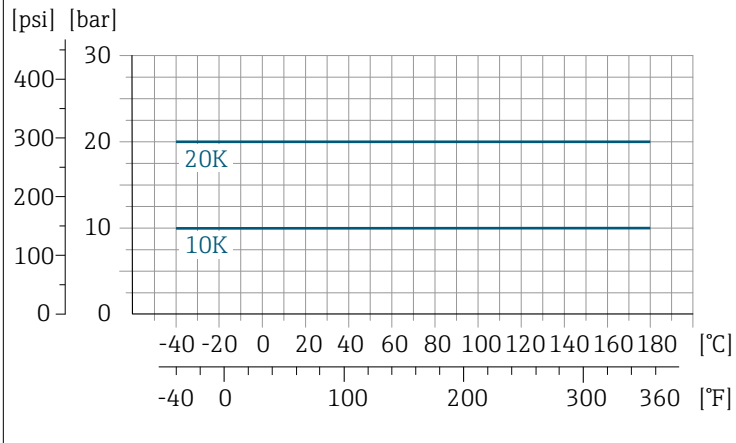

A0029397-EN

Fixed flange similar to AS 2129

Carbon steel

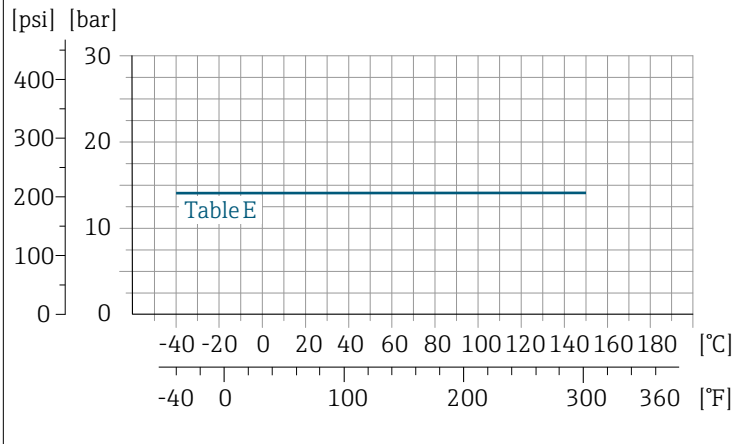

A0029398-EN

Fixed flange similar to AS 4087

Carbon steel

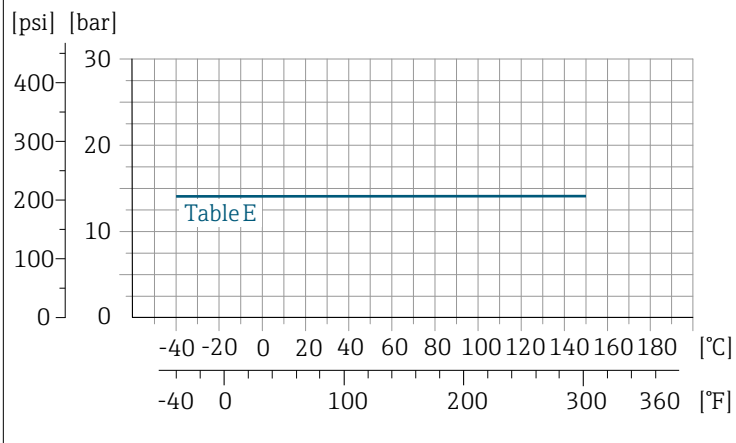

A0029398-EN

Lap joint flange/lap joint flange, stamped plate similar to EN 1092-1 and ASME B16.5

Stainless steel (-20 °C (-4 °F))
Carbon steel (-10 °C (14 °F))

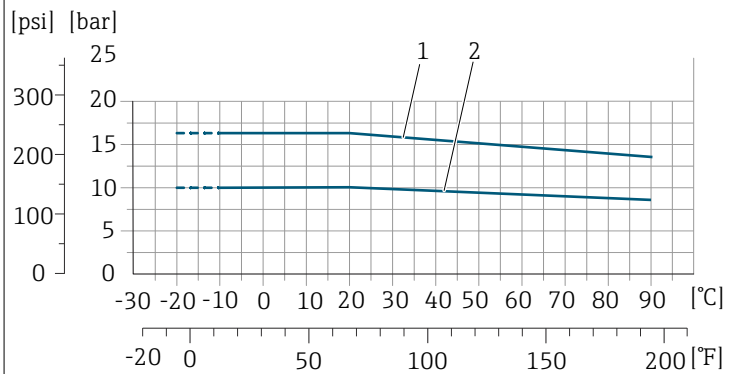

- 1 Lap joint flange PN16/Class 150
- 2 Lap joint flange, stamped plate PN10, lap joint flange PN10

A0038129-EN

Pressure tightness

Limit values for the absolute pressure depending on the liner and medium temperature

PFA	Nominal diameter		Absolute pressure in [mbar] ([psi])		
	[mm]	[in]	+25 °C (+77 °F)	+80 °C (+176 °F)	+100 to +180 °C (+212 to +356 °F)
	25	1	0 (0)	0 (0)	0 (0)
	32	-	0 (0)	0 (0)	0 (0)
	40	1 ½	0 (0)	0 (0)	0 (0)
	50	2	0 (0)	0 (0)	0 (0)
	65	-	0 (0)	0 (0)	0 (0)
	80	3	0 (0)	0 (0)	0 (0)
	100	4	0 (0)	0 (0)	0 (0)
	125	-	0 (0)	0 (0)	0 (0)
	150	6	0 (0)	0 (0)	0 (0)
	200	8	0 (0)	0 (0)	0 (0)

PTFE	Nominal diameter		Limit values for absolute pressure in [mbar] ([psi]) for medium temperatures:			
	[mm]	[in]	+25 °C (+77 °F)	+80 °C (+176 °F)	+100 °C (+212 °F)	+130 °C (+266 °F)
	15	½	0 (0)	0 (0)	0 (0)	100 (1.45)
	25	1	0 (0)	0 (0)	0 (0)	100 (1.45)
	32	-	0 (0)	0 (0)	0 (0)	100 (1.45)
	40	1 ½	0 (0)	0 (0)	0 (0)	100 (1.45)
	50	2	0 (0)	0 (0)	0 (0)	100 (1.45)
	65	-	0 (0)	-	40 (0.58)	130 (1.89)
	80	3	0 (0)	-	40 (0.58)	130 (1.89)
	100	4	0 (0)	-	135 (1.96)	170 (2.47)
	125	-	135 (1.96)	-	240 (3.48)	385 (5.58)
	150	6	135 (1.96)	-	240 (3.48)	385 (5.58)

PTFE	Nominal diameter		Limit values for absolute pressure in [mbar] ([psi]) for medium temperatures:			
	[mm]	[in]	+25 °C (+77 °F)	+80 °C (+176 °F)	+100 °C (+212 °F)	+130 °C (+266 °F)
	200	8	200 (2.90)	–	290 (4.21)	410 (5.95)
	250	10	330 (4.79)	–	400 (5.80)	530 (7.69)
	300	12	400 (5.80)	–	500 (7.25)	630 (9.14)
	350	14	470 (6.82)	–	600 (8.70)	730 (10.6)
	400	16	540 (7.83)	–	670 (9.72)	800 (11.6)
	450	18	No negative pressure permitted!			
	500	20	No negative pressure permitted!			
	600	24	No negative pressure permitted!			

Pressure loss

- No pressure loss: transmitter installed in a pipe with the same nominal diameter.
- Pressure loss information when adapters are used → *Adapters*,  31

Mechanical construction

Weight

All values refer to devices with flanges with a standard pressure rating. Weight data are guideline values. The weight may be lower than indicated depending on the pressure rating and design.

Different values due to different transmitter versions:

Transmitter version for the hazardous area: +1 kg (+2.2 lbs)

Transmitter version, order code for "Housing", option D "Polycarbonate":
-1 kg (-2.2 lbs)

Transmitter remote version

- Polycarbonate: 1.4 kg (3.1 lbs)
- Aluminum: 2.4 kg (5.3 lbs)

Sensor remote version

Aluminum sensor connection housing: see the information in the following table.

Weight in SI units

Nominal diameter		EN (DIN), AS ¹⁾		ASME		JIS	
[mm]	[in]	Pressure rating	[kg]	Pressure rating	[kg]	Pressure rating	[kg]
15	½	PN 40	7.2	Class 150	7.2	10K	4.5
25	1	PN 40	8.0	Class 150	8.0	10K	5.3
32	-	PN 40	8.7	Class 150	-	10K	5.3
40	1 ½	PN 40	10.1	Class 150	10.1	10K	6.3
50	2	PN 40	11.3	Class 150	11.3	10K	7.3
65	-	PN 16	12.7	Class 150	-	10K	9.1
80	3	PN 16	14.7	Class 150	14.7	10K	10.5
100	4	PN 16	16.7	Class 150	16.7	10K	12.7
125	-	PN 16	22.2	Class 150	-	10K	19
150	6	PN 16	26.2	Class 150	26.2	10K	22.5
200	8	PN 10	45.7	Class 150	45.7	10K	39.9
250	10	PN 10	65.7	Class 150	75.7	10K	67.4
300	12	PN 10	70.7	Class 150	111	10K	70.3
350	14	PN 10	105.7	Class 150	176	10K	79
400	16	PN 10	120.7	Class 150	206	10K	100
450	18	PN 10	161.7	Class 150	256	10K	128
500	20	PN 10	156.7	Class 150	286	10K	142
600	24	PN 10	208.7	Class 150	406	10K	188

1) For flanges according to AS, only DN 25 and 50 are available.

Weight in US units

Nominal diameter		ASME	
[mm]	[in]	Pressure rating	[lbs]
15	½	Class 150	15.9
25	1	Class 150	17.6

Nominal diameter		ASME	
[mm]	[in]	Pressure rating	[lbs]
40	1 ½	Class 150	22.3
50	2	Class 150	24.9
80	3	Class 150	32.4
100	4	Class 150	36.8
150	6	Class 150	57.7
200	8	Class 150	101
250	10	Class 150	167
300	12	Class 150	244
350	14	Class 150	387
400	16	Class 150	454
450	18	Class 150	564
500	20	Class 150	630
600	24	Class 150	895

Measuring pipe specification

Nominal diameter		Rating					Process connection internal diameter			
[mm]	[in]	EN (DIN)	ASME	AS 2129	AS 4087	JIS	PFA		PTFE	
		[bar]	[psi]	[bar]	[bar]	[bar]	[mm]	[in]	[mm]	[in]
15	½	PN 40	Class 150	-	-	20K	-	-	15	0.59
25	1	PN 40	Class 150	Table E	-	20K	23	0.91	26	1.02
32	-	PN 40	-	-	-	20K	32	1.26	35	1.38
40	1 ½	PN 40	Class 150	-	-	20K	36	1.42	41	1.61
50	2	PN 40	Class 150	Table E	PN 16	10K	48	1.89	52	2.05
65	-	PN 16	-	-	-	10K	63	2.48	67	2.64
80	3	PN 16	Class 150	-	-	10K	75	2.95	80	3.15
100	4	PN 16	Class 150	-	-	10K	101	3.98	104	4.09
125	-	PN 16	-	-	-	10K	126	4.96	129	5.08
150	6	PN 16	Class 150	-	-	10K	154	6.06	156	6.14
200	8	PN 10	Class 150	-	-	10K	201	7.91	202	7.95
250	10	PN 10	Class 150	-	-	10K	-	-	256	10.1
300	12	PN 10	Class 150	-	-	10K	-	-	306	12.0
350	14	PN 10	Class 150	-	-	10K	-	-	337	13.3
400	16	PN 10	Class 150	-	-	10K	-	-	387	15.2
450	18	PN 10	Class 150	-	-	10K	-	-	432	17.0
500	20	PN 10	Class 150	-	-	10K	-	-	487	19.2
600	24	PN 10	Class 150	-	-	10K	-	-	593	23.3

Materials

Transmitter housing	
Order code for "Housing"	<ul style="list-style-type: none"> ■ Option A: Compact, coated aluminum ■ Option B: Compact, coated aluminum + polycarbonate inspection window ■ Option N: Remote, polycarbonate ■ Option P: Remote, aluminum, coated ■ Option T: Remote, aluminum, coated + polycarbonate inspection window
Window material	<ul style="list-style-type: none"> ■ Order code for "Housing", option A: glass ■ Order code for "Housing", option G: polycarbonate ■ Order code for "Housing", option N: polycarbonate ■ Order code for "Housing", option P: glass ■ Order code for "Housing", option T: polycarbonate
Neck adapter	Order code for "Housing", option A, : Aluminum, coated
Sensor connection housing	
	Aluminum, AlSi10Mg, coated
Cable glands and entries	
Cable gland M20×1.5	<ul style="list-style-type: none"> ■ Non-hazardous area: plastic ■ Hazardous area: brass
Adapter for cable entry with G ½" or NPT ½" female thread	Nickel-plated brass
Connecting cable for remote version	
	Electrode and coil current cable: PVC cable with copper shield
Sensor housing	
DN 25 to 300 (1 to 12")	<ul style="list-style-type: none"> ■ Aluminum half-shell housing: aluminum, AlSi10Mg, coated ■ Fully welded carbon steel housing with protective varnish
DN 350 to 600 (14 to 24")	Fully welded carbon steel housing with protective varnish
Measuring tubes	
DN 25 to 600 (1 to 24")	Stainless steel: 1.4301, 1.4306, 304, 304L
Liner	
DN 25 to 200 (1 to 8")	PFA
DN 15 to 600 (1 to 24")	PTFE
Electrodes	
	<ul style="list-style-type: none"> ■ 1.4435 (316L) ■ Alloy C22, 2.4602 (UNS N06022) ■ Tantalum ■ Platinum ■ Titanium

Seals	
	As per DIN EN 1514-1, Form IBC
Process connections	
EN 1092-1 (DIN 2501)	<p>Fixed flange</p> <ul style="list-style-type: none"> ■ Carbon steel: <ul style="list-style-type: none"> ■ DN ≤ 300: S235JRG2, S235JR+N, P245GH, A105, E250C ■ DN 350 to 600: P245GH, S235JRG2, A105, E250C ■ Stainless steel: <ul style="list-style-type: none"> ■ DN ≤ 300: 1.4404, 1.4571, F316L ■ DN 350 to 600: 1.4571, F316L, 1.4404 <p>Lap joint flange</p> <ul style="list-style-type: none"> ■ Carbon steel DN ≤ 300: S235JRG2, A105, E250C ■ Stainless steel DN ≤ 300: 1.4306, 1.4404, 1.4571, F316L <p>Lap joint flange, stamped plate</p> <ul style="list-style-type: none"> ■ Carbon steel DN ≤ 300: S235JRG2 similar to S235JR+AR or 1.0038 ■ Stainless steel DN ≤ 300: 1.4301 similar to 304
ASME B16.5	<ul style="list-style-type: none"> ■ Carbon steel: A105 ■ Stainless steel: F316L
JIS B2220	<ul style="list-style-type: none"> ■ Carbon steel: A105, A350 LF2 ■ Stainless steel: F316L
AS 2129	Carbon steel: A105, E250C, P235GH, P265GH, S235JRG2
AS 4087	Carbon steel: A105, P265GH, S275JR
Accessories	
Weather protection cover	Stainless steel, 1.4404 (316L)
Pipe mounting kit (welding jig)	Stainless steel 1.4301 (304)
Wall mounting kit	Stainless steel 1.4301 (304)
Ground disks	<p>15 to 1200 mm (½ to 48 in)</p> <ul style="list-style-type: none"> ■ Stainless steel, 1.4435 (316L) ■ Alloy C22, 2.4602 (UNS N06022)

Fitted electrodes

Standard electrodes:

- Measuring electrodes
- Reference electrodes
- Empty pipe detection electrodes

Surface roughness

All data relate to parts in contact with medium.

Stainless steel electrodes, 1.4435 (F316L); Alloy C22, 2.4602 (UNS N06022), platinum, tantalum
 ≤ 0.3 to 0.5 µm (11.8 to 19.7 µin)

Liner with PFA:
 ≤ 0.4 µm (15.7 µin)

Local display

Operation concept

Operation method	Operation via: <ul style="list-style-type: none"> ▪ SmartBlue app ¹⁾ ▪ Commubox FXA291
Reliable operation	<ul style="list-style-type: none"> ▪ Operation in local language ▪ Uniform operating philosophy in device and in the SmartBlue App ▪ Write protection ▪ When electronics modules are replaced: configurations are transferred using the T-DAT Backup device memory. The device memory contains process data, device data and the event logbook. No reconfiguration is necessary.
Diagnostic behavior	Efficient diagnostic behavior increases measurement availability: <ul style="list-style-type: none"> ▪ Open remedial actions via local display and SmartBlue app ▪ Diverse simulation options ▪ Logbook of events that have occurred

1) Optional via order code "Display; operation", options H, J or K

IO-Link



The device-specific parameters are configured via IO-Link. There are specific configuration or operating programs from different manufacturers available to the user for this purpose. The device description file (IODD) is provided for the device.

IO-Link operating concept

Operator-oriented menu structure for user-specific tasks. Efficient diagnostic behavior increases measurement availability:

- Diagnostic messages
- Remedial action
- Simulation options

IODD download

Two options to download the IODD :

- www.endress.com/download
- <https://ioddfinder.io-link.com/>

www.endress.com/download

1. Select "Device Drivers".
2. Select the "IO Device Description (IODD)" entry under "Type".
3. Select "Product root".
4. Click "Search".
 - ↳ A list of search results is displayed.

Select the appropriate version and download.

<https://ioddfinder.io-link.com/>

1. Enter "Endress" as the manufacturer and select.
2. Select product name.
 - ↳ A list of search results is displayed.

Select the appropriate version and download.



For detailed IO-Link information, see "IO-Link" Special Documentation for the device → *Related documentation*, 6

Operation options

Local display	<p>Display element:</p> <ul style="list-style-type: none"> ▪ Depends on the orientation, automatic alignment of the local display ▪ Configuration of display format for measured variables and status variables
SmartBlue app	<ul style="list-style-type: none"> ▪ The SmartBlue app allows the user to put devices into operation and operate them. ▪ Based on Bluetooth ▪ No separate driver required ▪ Available for mobile handheld terminals, tablets and smartphones ▪ Suitable for convenient and secure access to devices in hard-to-reach locations or in hazardous areas ▪ Can be used within a 20 m (65.6 ft) radius of the device ▪ Encrypted and secure data transmission ▪ No data loss during commissioning and maintenance ▪ Diagnostic information and process information in real time

Operating tools

Operating tools	Operating unit	Interface	Additional information
DeviceCare SFE100	<ul style="list-style-type: none"> ▪ Notebook ▪ PC ▪ Tablet with Microsoft Windows system 	<ul style="list-style-type: none"> ▪ CDI service interface ▪ Fieldbus protocol 	Innovation brochure IN01047S
FieldCare SFE500	<ul style="list-style-type: none"> ▪ Notebook ▪ PC ▪ Tablet with Microsoft Windows system 	<ul style="list-style-type: none"> ▪ CDI service interface ▪ Fieldbus protocol 	Operating Instructions BA00027S and BA00059S
SmartBlue app	<ul style="list-style-type: none"> ▪ Devices with iOS: iOS9.0 or higher ▪ Devices with Android: Android 4.4 KitKat or higher 	Bluetooth	Endress+HauserSmartBlue App: <ul style="list-style-type: none"> ▪ Google Playstore (Android) ▪ iTunes Apple Shop (iOS devices)

Certificates and approvals

Non-Ex approval

- cCSAus
- EAC
- UKCA

Pressure Equipment Directive

- CRN
- PED Cat. II/III
- PESR Cat. II/III

Radio approval

The device has radio approvals.

Additional approvals

- Food Contact Materials Regulation (EC) 1935/2004
A declaration for a specific serial number that confirms compliance with the requirements of (EC) 1935/2004 is only generated for measuring instruments with the order code for "Test, certificate", option J1 "EU Food Contact Materials (EC) 1935/2004.
- FDA
A declaration for a specific serial number that confirms compliance with FDA requirements is only generated for measuring instruments with the order code for "Test, certificate", option J2 "US Food Contact Materials FDA CFR 21".
- USP Class VI
- TSE/BSE Certificate of Suitability
- VDS (for stationary fire extinguishing systems)

Additional certification

- IO-Link
Self-certification with Manufacturer Declaration
- CRN approval
Some device versions have a CRN approval. A CRN-approved process connection with a CSA approval must be ordered for a CRN-approved device.
- EN10204-3.1 material certificate, wetted parts and sensor housing (order code for "Test, certificate", option JA)
- Pressure test, internal process, test report (order code for "Test, certificate", option JB)
- Surface roughness test ISO4287/Ra, (wetted parts), test report (option JE)
- Compliance with requirements derived from cGMP, Declaration (option JG)

External standards and guidelines

- IEC/EN 60529
Degrees of protection provided by enclosure (IP code)
- IEC/EN 60068-2-6
Environmental influences: Test procedure - Test Fc: vibration (sinusoidal)
- IEC/EN 60068-2-31
Environmental influences: Test procedure - Test Ec: shocks due to rough handling, primarily for devices.
- IEC/EN 61010-1
Safety requirements for electrical equipment for measurement, control and laboratory use - general requirements.
- GB 30439.5
Safety requirements for industrial automation products - Part 5: Flowmeter safety requirements
- CAN/CSA-C22.2 No. 61010-1-12
Safety Requirements for Electrical Equipment for Measurement, Control and Laboratory Use - Part 1 General Requirements.
- IEC 61131-9
Interface for communication with small sensors and actuators via a point-to-point connection
- IEC/EN 61326
Emission in accordance with Class A requirements; Electromagnetic compatibility (EMC requirements)

- ANSI/ISA-61010-1 (82.02.01)
Safety Requirements for Electrical Equipment for Measurement, Control and Laboratory Use - Part 1 General Requirements.
- ETSI EN 300 328
Guidelines for 2.4 GHz radio components
- EN 301489
Electromagnetic compatibility and radio spectrum matters (ERM).

Application packages

Use

Many different application packages are available to enhance the functionality of the device. Such packages might be needed to address safety aspects or specific application requirements.

The application packages can be ordered with the device or subsequently from Endress+Hauser. Detailed information on the relevant order code is available from your local Endress+Hauser sales organization or on the product page of the Endress+Hauser website: www.endress.com.

Heartbeat Verification + Monitoring

Heartbeat Verification

Availability depends on the product structure.

Meets the requirement for traceable verification according to DIN ISO 9001:2015 Clause 7.6 a) "Control of monitoring and measuring equipment":

- Functional testing in the installed state without interrupting the process.
- Traceable verification results on request, including report.
- Simple testing process with operating interfaces.
- Clear measuring point assessment (pass/fail) with high total test coverage within the framework of manufacturer specifications.
- Extension of calibration intervals according to operator's risk evaluation.

Heartbeat Monitoring

Availability depends on the product structure.

Heartbeat Monitoring continuously provides data characteristic of the measuring principle to an external condition monitoring system, facilitating preventive maintenance or process analysis. This data enables the operator to:

- Draw conclusions - using this data and other information - about the measuring performance over time.
- Schedule servicing in time.
- Monitor the process quality or product quality .

14 Dimensions in SI units

Compact version	114
Order code for "Housing", option A "Aluminum, coated"	114
Order code for "Housing", option A "Aluminum, coated"; Zone 1, Division 1	115
Order code for "Housing", option M "Compact, polycarbonate"	116
Remote version	117
Transmitter remote version	117
Sensor remote version	118
Fixed flange	119
Flange similar to EN 1092-1 (DIN 2501/DIN 2512N): PN 10	119
Flange similar to EN 1092-1 (DIN 2501/DIN 2512N): PN 16	120
Flange similar to EN 1092-1 (DIN 2501/DIN 2512N): PN 25	121
Flange similar to EN 1092-1: PN 40	122
Flange similar to ASME B16.5, Class 150	123
Flange similar to ASME B16.5, Class 300	124
Flange similar to JIS B2220, 10K	125
Flange similar to JIS B2220, 20K	126
Flange similar to AS 2129, Tab. E	127
Flange similar to AS 4087, PN 16	128
Lap joint flange	129
Lap joint flange similar to EN 1092-1: PN 10	129
Lap joint flange similar to EN 1092-1: PN 16	130
Lap joint flange similar to ASME B16.5, Class 150	131
Lap joint flange, stamped plate	132
Lap joint flange, stamping plate similar to EN 1092-1: PN 10	132
Accessories	133
Weather protection cover	133
Ground disks for flanges	133

Compact version

Order code for "Housing", option A "Aluminum, coated"

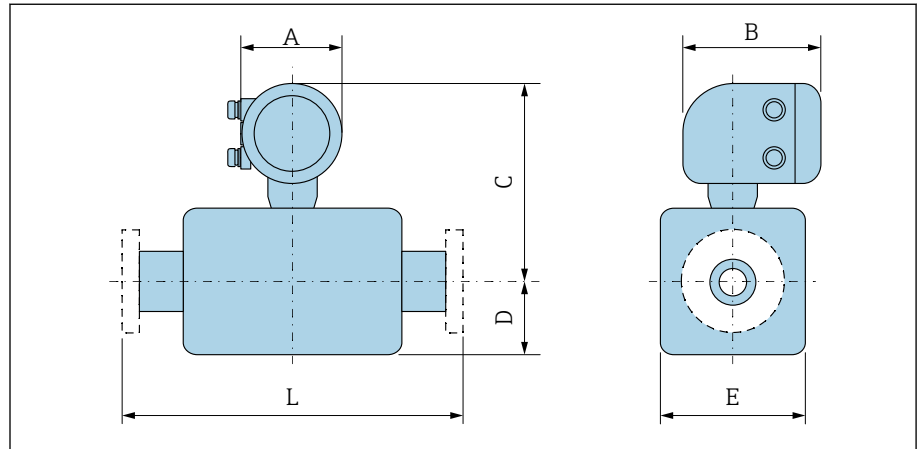

DN		A ¹⁾	B	C ²⁾	D	E	L ³⁾
[mm]	[in]	[mm]	[mm]	[mm]	[mm]	[mm]	[mm]
15	½	139	178	258	84	120	200
25	1	139	178	258	84	120	200
32	–	139	178	258	84	120	200
40	1 ½	139	178	258	84	120	200
50	2	139	178	258	84	120	200
65	–	139	178	283	109	180	200
80	3	139	178	283	109	180	200
100	4	139	178	283	109	180	250
125	–	139	178	323	150	260	250
150	6	139	178	323	150	260	300
200	8	139	178	348	180	324	350
250	10	139	178	373	205	400	450
300	12	139	178	398	230	460	500
350	14	139	178	457	282	564	550
400	16	139	178	483	308	616	600
450	18	139	178	508	333	666	650
500	20	139	178	533	359	717	650
600	24	139	178	586	411	821	780

- 1) Depending on the cable gland used: values up to +30 mm
- 2) With order code for "Sensor option", option CG "Sensor extended neck for insulation": values + 110 mm
- 3) Total installed length is independent of the process connections. Installed length according to DVGW (German Technical and Scientific Association for Gas and Water).

Order code for "Housing", option A "Aluminum, coated"; Zone 1, Division 1

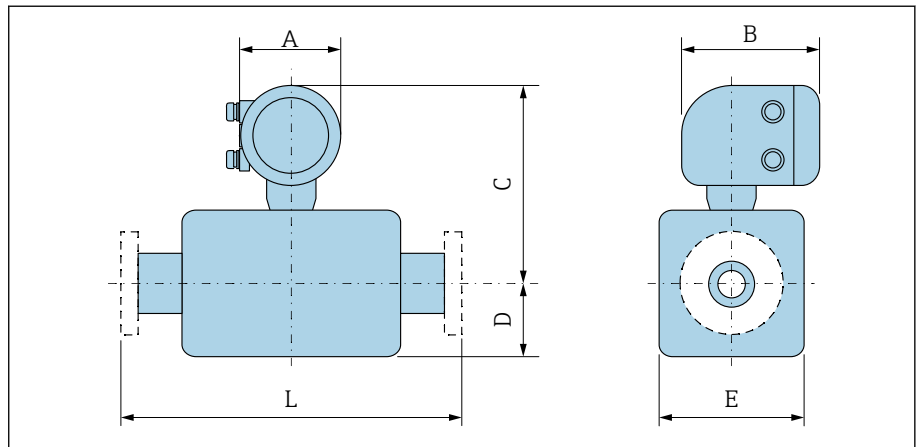

A0042708

DN		A ¹⁾	B ²⁾	C ³⁾	D	E	L ⁴⁾
[mm]	[in]	[mm]	[mm]	[mm]	[mm]	[mm]	[mm]
15	½	139	206	281	84	120	200
25	1	139	206	281	84	120	200
32	-	139	206	281	84	120	200
40	1 ½	139	206	281	84	120	200
50	2	139	206	281	84	120	200
65	-	139	206	306	109	180	200
80	3	139	206	306	109	180	200
100	4	139	206	306	109	180	250
125	-	139	206	346	150	260	250
150	6	139	206	346	150	260	300
200	8	139	206	371	180	324	350
250	10	139	206	396	205	400	450
300	12	139	206	421	230	460	500
350	14	139	206	480	282	564	550
400	16	139	206	506	308	616	600
450	18	139	206	531	333	666	650
500	20	139	206	556	359	717	650
600	24	139	206	609	411	821	780

- 1) Depending on the cable gland used: values up to +30 mm
- 2) For Ex de: values +10 mm
- 3) With order code for "Sensor option", option CG "Sensor extended neck for insulation": values +110 mm
- 4) Total installed length is independent of the process connections. Installed length according to DVGW (German Technical and Scientific Association for Gas and Water).

Order code for "Housing", option M "Compact, polycarbonate"

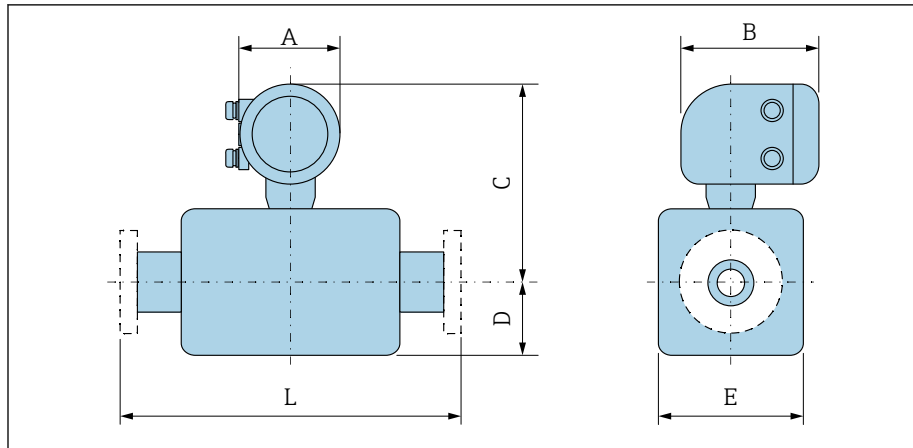

A0042708

DN		A ¹⁾	B	C ²⁾	D	E	L ³⁾
[mm]	[in]	[mm]	[mm]	[mm]	[mm]	[mm]	[mm]
15	½	132	172	255	84	120	200
25	1	132	172	255	84	120	200
32	–	132	172	255	84	120	200
40	1 ½	132	172	255	84	120	200
50	2	132	172	255	84	120	200
65	–	132	172	280	109	180	200
80	3	132	172	280	109	180	200
100	4	132	172	280	109	180	250
125	–	132	172	320	150	260	250
150	6	132	172	320	150	260	300
200	8	132	172	345	180	324	350
250	10	132	172	370	205	400	450
300	12	132	172	395	230	460	500
350	14	132	172	454	282	564	550
400	16	132	172	480	308	616	600
450	18	132	172	505	333	666	650
500	20	132	172	530	359	717	650
600	24	132	172	583	411	821	780

- 1) Depending on the cable gland used: values up to +30 mm
- 2) With order code for "Sensor option", option CG "Sensor extended neck for insulation": values + 110 mm
- 3) Total installed length is independent of the process connections. Installed length according to DVGW (German Technical and Scientific Association for Gas and Water).

Remote version

Transmitter remote version

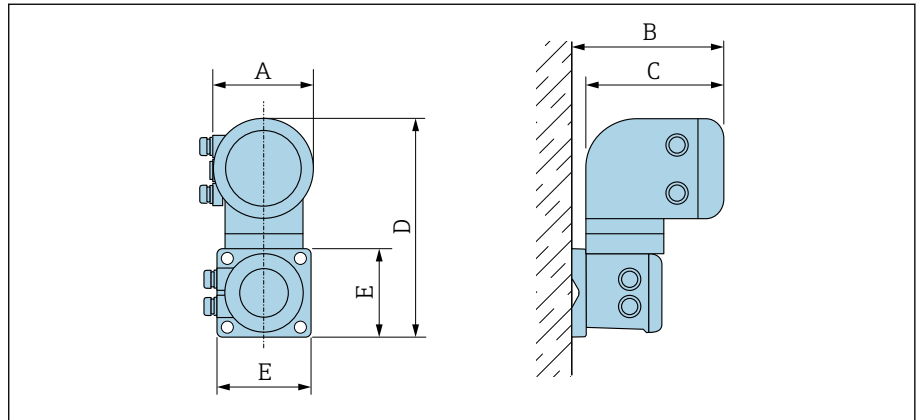

A0042715

Order code for "Housing"	A ¹⁾ [mm]	B [mm]	C [mm]	D [mm]	E [mm]
Option N "Remote, polycarbonate"	132	187	172	307	130
Option P and T "Remote, coated aluminum"	139	185	178	309	130

1) Depending on the cable entry used: values up to + 30 mm

Sensor remote version

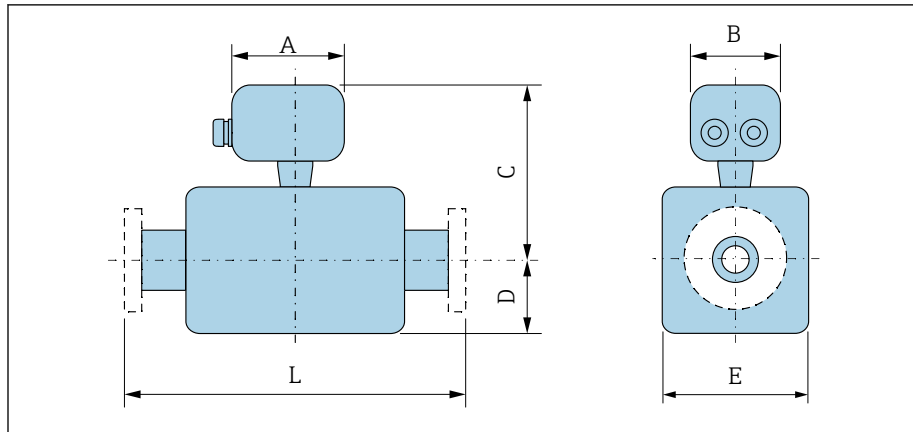

A0042718

DN		A ¹⁾	B	C ²⁾	D	E	L ³⁾
[mm]	[in]	[mm]	[mm]	[mm]	[mm]	[mm]	[mm]
15	½	148	136	197	84	120	200
25	1	148	136	197	84	120	200
32	–	148	136	197	84	120	200
40	1 ½	148	136	197	84	120	200
50	2	148	136	197	84	120	200
65	–	148	136	222	109	180	200
80	3	148	136	222	109	180	200
100	4	148	136	222	109	180	250
125	–	148	136	262	150	260	250
150	6	148	136	262	150	260	300
200	8	148	136	287	180	324	350
250	10	148	136	312	205	400	450
300	12	148	136	337	230	460	500
350	14	148	136	396	282	564	550
400	16	148	136	422	308	616	600
450	18	148	136	447	333	666	650
500	20	148	136	472	359	717	650
600	24	148	136	525	411	821	780

- 1) Depending on the cable gland used: values up to +30 mm
- 2) With order code for "Sensor option", option CG "Sensor extended neck for insulation" or order code for "Liner", option B "PFA high temperature": values +110 mm
- 3) Total installed length is independent of the process connections. Installed length according to DVGW (German Technical and Scientific Association for Gas and Water).

Fixed flange

Flange similar to EN 1092-1 (DIN 2501/DIN 2512N): PN 10

- Carbon steel: order code for "Process connection", option D2K
- Stainless steel: order code for "Process connection", option D2S

Surface roughness: EN 1092-1 Form B1 (DIN 2526 Form C), Ra 6.3 to 12.5 μm

E: Internal diameter depends on the liner \rightarrow *Measuring pipe specification*, 106.

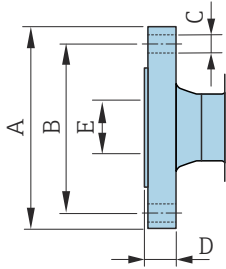

A0041915

DN [mm]	A [mm]	B [mm]	C [mm]	D [mm]
200	340	295	8 × Ø22	26
250	395	350	12 × Ø22	28
300	445	400	12 × Ø22	28
350	505	460	16 × Ø22	26
400	565	515	16 × Ø26	26
450	615	565	20 × Ø26	26
500	670	620	20 × Ø26	28
600	780	725	20 × Ø30	30

Flange similar to EN 1092-1 (DIN 2501/DIN 2512N): PN 16

- Carbon steel: order code for "Process connection", option D3K
- Stainless steel: order code for "Process connection", option D3S

Surface roughness: EN 1092-1 Form B1 (DIN 2526 Form C), Ra 6.3 to 12.5 μm

E: Internal diameter depends on the liner \rightarrow *Measuring pipe specification*,  106.

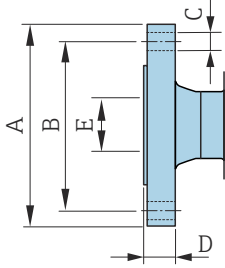

A0041915

DN [mm]	A [mm]	B [mm]	C [mm]	D [mm]
65	185	145	8 × Ø18	20
80	200	160	8 × Ø18	20
100	220	180	8 × Ø18	22
125	250	210	8 × Ø18	24
150	285	240	8 × Ø22	24
200	340	295	12 × Ø22	26
250	405	355	12 × Ø26	32
300	460	410	12 × Ø26	32
350	520	470	16 × Ø26	30
400	580	525	16 × Ø30	32
450	640	585	20 × Ø30	34
500	715	650	20 × Ø33	36
600	840	770	20 × Ø36	40

Flange similar to EN 1092-1 (DIN 2501/DIN 2512N): PN 25

- Carbon steel: order code for "Process connection", option D4K
- Stainless steel: order code for "Process connection", option D4S

Surface roughness: EN 1092-1 Form B1 (DIN 2526 Form C), Ra 6.3 to 12.5 μm

E: Internal diameter depends on the liner \rightarrow *Measuring pipe specification*, 106.

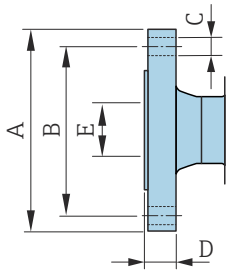

A0041915

DN [mm]	A [mm]	B [mm]	C [mm]	D [mm]
200	360	310	12 × Ø26	32
250	425	370	12 × Ø30	36
300	485	430	16 × Ø30	40
350	555	490	16 × Ø33	38
400	620	550	16 × Ø36	40
450	670	600	20 × Ø36	46
500	730	660	20 × Ø36	48
600	845	770	20 × Ø39	48

Flange similar to EN 1092-1: PN 40

- Carbon steel: order code for "Process connection", option D5K
- Stainless steel: order code for "Process connection", option D5S

Surface roughness: EN 1092-1 Form B1 (DIN 2526 Form C), Ra 6.3 to 12.5 μm

E: Internal diameter depends on the liner → *Measuring pipe specification*,  106.

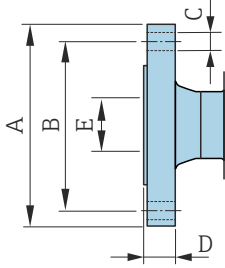

A0041915

DN [mm]	A [mm]	B [mm]	C [mm]	D [mm]
15	95	65	4 × Ø14	14
25	115	85	4 × Ø14	16
32	140	100	4 × Ø18	18
40	150	110	4 × Ø18	18
50	165	125	4 × Ø18	20
65	185	145	8 × Ø18	24
80	200	160	8 × Ø18	26
100	235	190	8 × Ø22	26
125	270	220	8 × Ø26	28
150	300	250	8 × Ø26	30

Flange similar to ASME B16.5, Class 150

- Carbon steel: order code for "Process connection", option A1K
- Stainless steel: order code for "Process connection", option A1S

Surface roughness: Ra 6.3 to 12.5 μm

E: Internal diameter depends on the liner \rightarrow *Measuring pipe specification*, 106

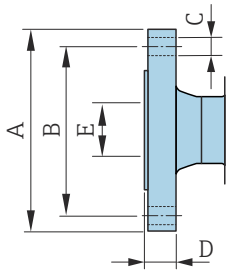

A0041915

DN [mm]	A [mm]	B [mm]	C [mm]	D [mm]
15	88.9	60.5	4 × Ø16	9.6
25	108	79.2	4 × Ø16	12.6
40	127	98.6	4 × Ø16	15.9
50	152.4	120.7	4 × Ø19.1	17.5
80	190.5	152.4	4 × Ø19.1	22.3
100	228.6	190.5	8 × Ø19.1	22.3
150	279.4	241.3	8 × Ø22.4	23.8
200	342.9	298.5	8 × Ø22.4	26.8
250	406.4	362	12 × Ø25.4	29.6
300	482.6	431.8	12 × Ø25.4	30.2
350	535	476.3	12 × Ø28.6	35.4
400	595	539.8	16 × Ø28.6	37
450	635	577.9	16 × Ø31.8	40.1
500	700	635	20 × Ø31.8	43.3
600	815	749.3	20 × Ø34.9	48.1

Flange similar to ASME B16.5, Class 300

- Carbon steel: order code for "Process connection", option A2K
- Stainless steel: order code for "Process connection", option A2S

Surface roughness: Ra 6.3 to 12.5 μm

E: Internal diameter depends on the liner \rightarrow *Measuring pipe specification*,  106

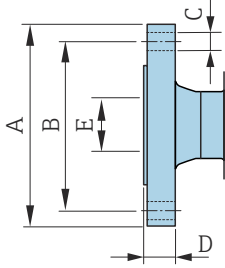

A0041915

DN [mm]	A [mm]	B [mm]	C [mm]	D [mm]
15	95.3	66.5	4 × Ø16	12.6
25	123.9	88.9	4 × Ø19.1	15.9
40	155.4	114.3	4 × Ø22.4	19
50	165.1	127	8 × Ø19.1	20.8
80	209.6	168.1	8 × Ø22.4	26.8
100	254	200.2	8 × Ø22.4	30.2
150	317.5	269.7	12 × Ø22.4	35

Flange similar to JIS B2220, 10K

- Carbon steel: order code for "Process connection", option N3K
- Stainless steel: order code for "Process connection", option N3S

Surface roughness: Ra 6.3 to 12.5 μm

E: Internal diameter depends on the liner \rightarrow *Measuring pipe specification*,  106

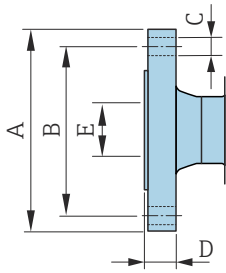

A0041915

DN [mm]	A [mm]	B [mm]	C [mm]	D [mm]
50	155	120	4 × Ø19	16
65	175	140	4 × Ø19	18
80	185	150	8 × Ø19	18
100	210	175	8 × Ø19	18
125	250	210	8 × Ø23	20
150	280	240	8 × Ø23	22
200	330	290	12 × Ø23	22
250	400	355	12 × Ø25	24
300	445	400	16 × Ø25	24

Flange similar to JIS B2220, 20K

- Carbon steel: order code for "Process connection", option N4K
- Stainless steel: order code for "Process connection", option N4S

Surface roughness: Ra 6.3 to 12.5 µm

E: Internal diameter depends on the liner → *Measuring pipe specification*, 106

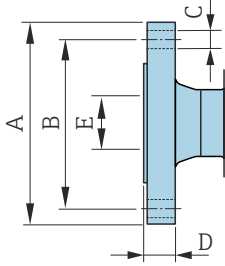

A0041915

DN [mm]	A [mm]	B [mm]	C [mm]	D [mm]
15	95	70	4 × Ø15	14
25	125	90	4 × Ø19	16
32	135	100	4 × Ø19	18
40	140	105	4 × Ø19	18
50	155	120	8 × Ø19	18
65	175	140	8 × Ø19	20
80	200	160	8 × Ø23	22
100	225	185	8 × Ø23	24
125	270	225	8 × Ø25	26
150	305	260	12 × Ø25	28
200	350	305	12 × Ø25	30
250	430	380	12 × Ø27	34
300	480	430	16 × Ø27	36

Flange similar to AS 2129, Tab. E

Order code for "Process connection", option M2K

Surface roughness: Ra 6.3 to 12.5 μm

E: Internal diameter depends on the liner \rightarrow *Measuring pipe specification*, 106.

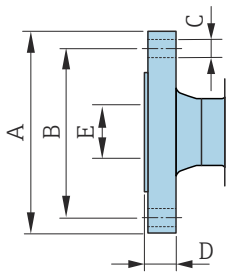

A0041915

DN [mm]	A [mm]	B [mm]	C [mm]	D [mm]
80	185	146	4 × Ø18	12
100	215	178	8 × Ø18	13
150	280	235	8 × Ø22	17
200	335	292	8 × Ø22	19
250	405	356	12 × Ø22	22
300	455	406	12 × Ø26	25
350	525	470	12 × Ø26	30
400	580	521	12 × Ø26	32
450	640	584	16 × Ø26	35
500	705	641	16 × Ø26	38
600	825	756	16 × Ø33	48

Flange similar to AS 4087, PN 16

Order code for "Process connection", option M3K

Surface roughness: Ra 6.3 to 12.5 μm

E: Internal diameter depends on the liner \rightarrow *Measuring pipe specification*,  106.

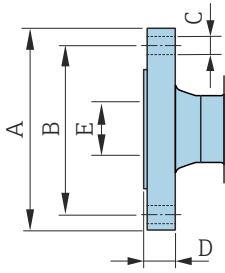

A0041915

DN [mm]	A [mm]	B [mm]	C [mm]	D [mm]
80	185	146	4 × Ø18	12
100	215	178	4 × Ø18	13
150	280	235	8 × Ø18	13
200	335	292	8 × Ø18	19
250	405	356	8 × Ø22	19
300	455	406	12 × Ø22	23
350	525	470	12 × Ø26	30
375	550	495	12 × Ø26	30
400	580	521	12 × Ø26	32
450	640	584	12 × Ø26	30
500	705	641	16 × Ø26	38
600	825	756	16 × Ø30	48

Lap joint flange

Lap joint flange similar to EN 1092-1: PN 10

- Carbon steel: order code for "Process connection", option D22
- Stainless steel: order code for "Process connection", option D24

Surface roughness (flange): Ra 6.3 to 12.5 μm

F: Internal diameter depends on the liner → *Measuring pipe specification*, 106

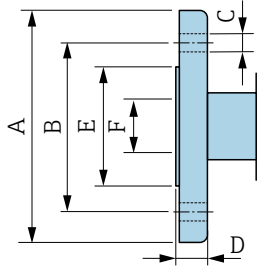

A0042254

DN [mm]	A [mm]	B [mm]	C [mm]	D [mm]	E [mm]
200	340	295	8 × Ø22	24	264
250	395	350	12 × Ø22	26	317
300	445	400	12 × Ø22	26	367

Lap joint flange similar to EN 1092-1: PN 16

- Carbon steel: order code for "Process connection", option D32
- Stainless steel: order code for "Process connection", option D34

Surface roughness (flange): Ra 6.3 to 12.5 µm

F: Internal diameter depends on the liner → *Measuring pipe specification*, 106

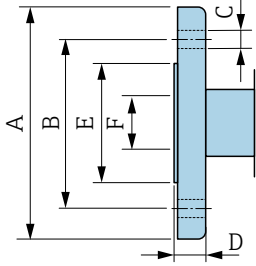

A0042254

DN [mm]	A [mm]	B [mm]	C [mm]	D [mm]	E [mm]
25	115	85	4 × Ø14	16	49
32	140	100	4 × Ø18	18	65
40	150	110	4 × Ø18	18	71
50	165	125	4 × Ø18	20	88
65	185	145	8 × Ø18	20	103
80	200	160	8 × Ø18	20	120
100	220	180	8 × Ø18	22	148
125	250	210	8 × Ø18	22	177
150	285	240	8 × Ø22	24	209
200	340	295	12 × Ø22	26	264
250	405	355	12 × Ø26	29	317
300	460	410	12 × Ø26	32	367

Lap joint flange similar to ASME B16.5, Class 150

- Carbon steel: order code for "Process connection", option A12
- Stainless steel: order code for "Process connection", option A14

Surface roughness (flange): Ra 6.3 to 12.5 μm

F: Internal diameter depends on the liner → *Measuring pipe specification*, 106

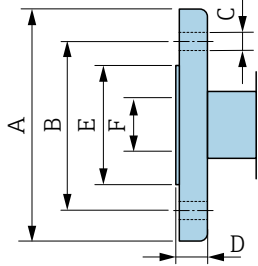

A0042254

DN [mm]	A [mm]	B [mm]	C [mm]	D [mm]	E [mm]
25	110	80	4 × Ø16	14	49
40	125	98	4 × Ø16	17.5	71
50	150	121	4 × Ø19	19	88
80	190	152	4 × Ø19	24	120
100	230	190	8 × Ø19	24	148
150	280	241	8 × Ø23	25	209
200	345	298	8 × Ø23	29	264
250	405	362	12 × Ø25	30	317
300	485	432	12 × Ø25	32	378

Lap joint flange, stamped plate

Lap joint flange, stamping plate similar to EN 1092-1: PN 10

- Carbon steel: order code for "Process connection", option D21
- Stainless steel: order code for "Process connection", option D23

Surface roughness (flange): Ra 6.3 to 12.5 µm

F: Internal diameter depends on the liner → *Measuring pipe specification*, 106

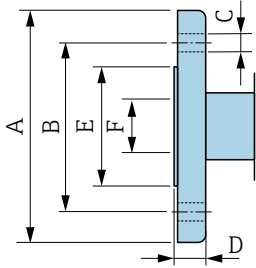

A0042254

DN [mm]	A [mm]	B [mm]	C [mm]	D [mm]	E [mm]
25	115	85	4 x Ø13.5	16.5	49
32	140	100	4 x Ø17.5	17	65
40	150	110	4 x Ø17.5	16.5	71
50	165	125	4 x Ø17.5	18.5	88
65	185	145	4 x Ø17.5	20	103
80	200	160	8 x Ø17.5	23.5	120
100	220	180	8 x Ø17.5	24.5	148
125	250	210	8 x Ø17.5	24	177
150	285	240	8 x Ø21.5	25	209
200	340	295	8 x Ø21.5	27.5	264
250	405	350	12 x Ø21.5	30.5	317
300	445	400	12 x Ø21.5	34.5	367

Accessories

Weather protection cover

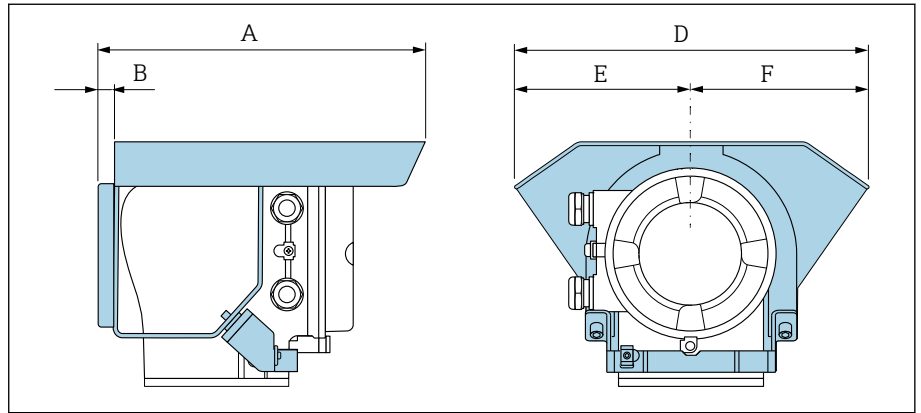

A0042332

A [mm]	B [mm]	D [mm]	E [mm]	F [mm]
257	12	280	140	140

Ground disks for flanges

DN 15 to 300 (½ to 12")		DN	Pressure rating	A	B	C ¹⁾	D	E	F
		[mm]	[in]	[mm]	[mm]	[mm]	[mm]	[mm]	[mm]
	15	½"	2)	73.0	6.5	2	16	43	61.5
	25	1"	2)	87.5	6.5	2	26	62	77.5
	32	1 ¼"	2)	94.5	6.5	2	35	80	87.5
	40	1 ½"	2)	103	6.5	2	41	82	101
	50	2"	2)	108	6.5	2	52	101	115.5
	65	2 ½"	2)	118	6.5	2	68	121	131.5
	80	3"	2)	135	6.5	2	80	131	154.5
	100	4"	2)	153	6.5	2	104	156	186.5
	125	5"	2)	160	6.5	2	130	187	206.5
	150	6"	2)	184	6.5	2	158	217	256
	200	8"	2)	205	6.5	2	206	267	288
	250	10"	2)	240	6.5	2	260	328	359
300	12"		PN 10 PN 16 Cl. 150	273	6.5	2	312	375	413

- 1) Material thickness
- 2) In the case of DN 15 to 250, ground disks can be used for all the flange standards/pressure ratings which can be supplied in the standard version.

DN 300 to 600 (12 to 24")	DN		Rating	A	B	C ¹⁾	D	E	F
	[mm]	[in]							
	300	12"	PN 25 JIS 10K JIS 20K	268	9	2	310	375	404
	350	14"	PN 6 PN 10 PN 16	365	9	2	343	420	479
	375	15"	PN 16	395	9	2	393	461	523
	400	16"	PN 6 PN 10 PN 16	395	9	2	393	470	542
	450	18"	PN 6 PN 10 PN 16	417	9	2	439	525	583
	500	20"	PN 6 PN 10 PN 16	460	9	2	493	575	650
	600	24"	PN 6 PN 10 PN 16	522	9	2	593	676	766

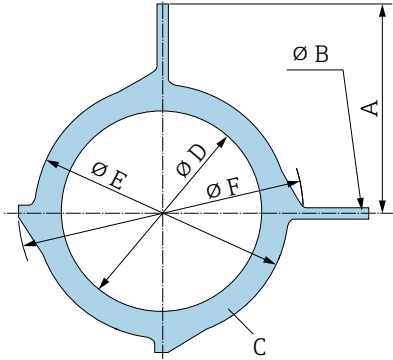

A0042323

1) Material thickness

15 Dimensions in US units

Compact version	136
Order code for "Housing", option A "Aluminum, coated"	136
Order code for "Housing", option A "Aluminum, coated"; Zone 1, Division 1	137
Order code for "Housing", option M "Compact, polycarbonate"	138
Remote version	139
Transmitter remote version	139
Sensor remote version	140
Fixed flange	141
Flange similar to ASME B16.5, Class 150	141
Flange similar to ASME B16.5, Class 300	141
Lap joint flange	142
Lap joint flange similar to ASME B16.5, Class 150	142
Accessories	143
Weather protection cover	143
Ground disks for flanges	143

Compact version

Order code for "Housing", option A "Aluminum, coated"

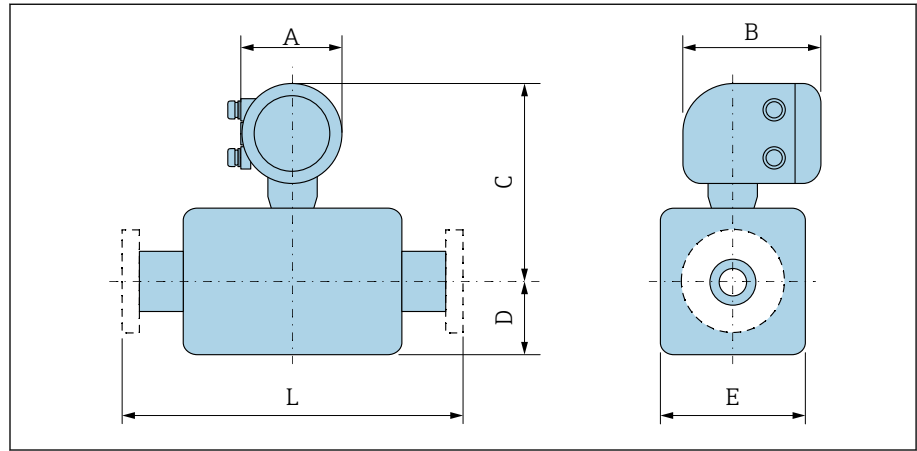

DN		A ¹⁾	B	C ²⁾	D	E	L ³⁾
[mm]	[in]	[in]	[in]	[in]	[in]	[in]	[in]
15	½	5.47	7.01	10.16	3.31	4.72	7.87
25	1	5.47	7.01	10.16	3.31	4.72	7.87
32	–	5.47	7.01	10.16	3.31	4.72	7.87
40	1 ½	5.47	7.01	10.16	3.31	4.72	7.87
50	2	5.47	7.01	10.16	3.31	4.72	7.87
65	–	5.47	7.01	11.14	4.29	7.09	7.87
80	3	5.47	7.01	11.14	4.29	7.09	7.87
100	4	5.47	7.01	11.14	4.29	7.09	9.84
125	–	5.47	7.01	12.72	5.91	10.24	9.84
150	6	5.47	7.01	12.72	5.91	10.24	11.81
200	8	5.47	7.01	13.7	7.09	12.76	13.78
250	10	5.47	7.01	14.69	8.07	15.75	17.72
300	12	5.47	7.01	15.67	9.06	18.11	19.69
350	14	5.47	7.01	17.99	11.1	22.2	21.65
400	16	5.47	7.01	19.02	12.13	24.25	23.62
450	18	5.47	7.01	20	13.11	26.22	25.59
500	20	5.47	7.01	20.98	14.13	28.23	25.59
600	24	5.47	7.01	23.07	16.18	32.32	30.71

- 1) Depending on the cable gland used: values up to +1.18 in
- 2) With order code for "Sensor option", option CG "Sensor extended neck for insulation": values +4.33 in
- 3) Total installed length is independent of the process connections. Installed length according to DVGW (German Technical and Scientific Association for Gas and Water).

Order code for "Housing", option A "Aluminum, coated"; Zone 1, Division 1

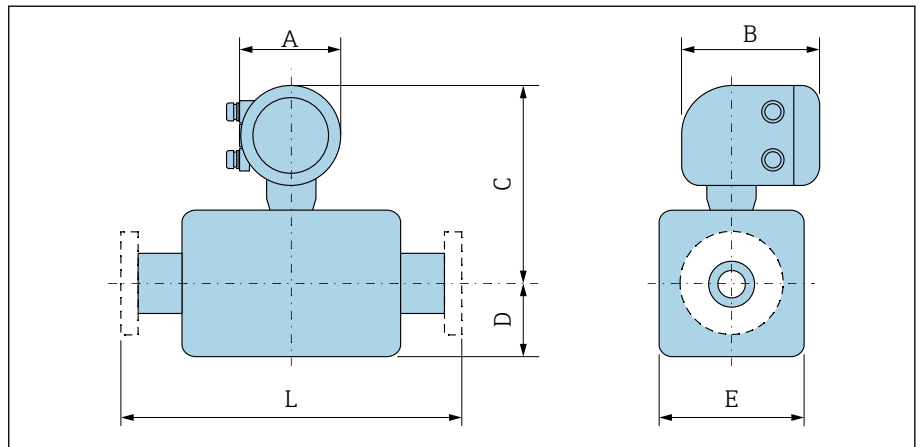

A0042708

DN		A ¹⁾	B ²⁾	C ³⁾	D	E	L ⁴⁾
[mm]	[in]	[in]	[in]	[in]	[in]	[in]	[in]
15	½	5.47	8.11	11.06	3.31	4.72	7.87
25	1	5.47	8.11	11.06	3.31	4.72	7.87
32	–	5.47	8.11	11.06	3.31	4.72	7.87
40	1 ½	5.47	8.11	11.06	3.31	4.72	7.87
50	2	5.47	8.11	11.06	3.31	4.72	7.87
65	–	5.47	8.11	12.05	4.29	7.09	7.87
80	3	5.47	8.11	12.05	4.29	7.09	7.87
100	4	5.47	8.11	12.05	4.29	7.09	9.84
125	–	5.47	8.11	13.62	5.91	10.24	9.84
150	6	5.47	8.11	13.62	5.91	10.24	11.81
200	8	5.47	8.11	14.61	7.09	12.76	13.78
250	10	5.47	8.11	15.59	8.07	15.75	17.72
300	12	5.47	8.11	16.57	9.06	18.11	19.69
350	14	5.47	8.11	18.9	11.1	22.2	21.65
400	16	5.47	8.11	19.92	12.13	24.25	23.62
450	18	5.47	8.11	20.91	13.11	26.22	25.59
500	20	5.47	8.11	21.89	14.13	28.23	25.59
600	24	5.47	8.11	23.98	16.18	32.32	30.71

- 1) Depending on the cable gland used: values up to +1.18 in
- 2) For Ex de: values +0.39 in
- 3) With order code for "Sensor option", option CG "Sensor extended neck for insulation": values +4.33 in
- 4) Total installed length is independent of the process connections. Installed length according to DVGW (German Technical and Scientific Association for Gas and Water).

Order code for "Housing", option M "Compact, polycarbonate"

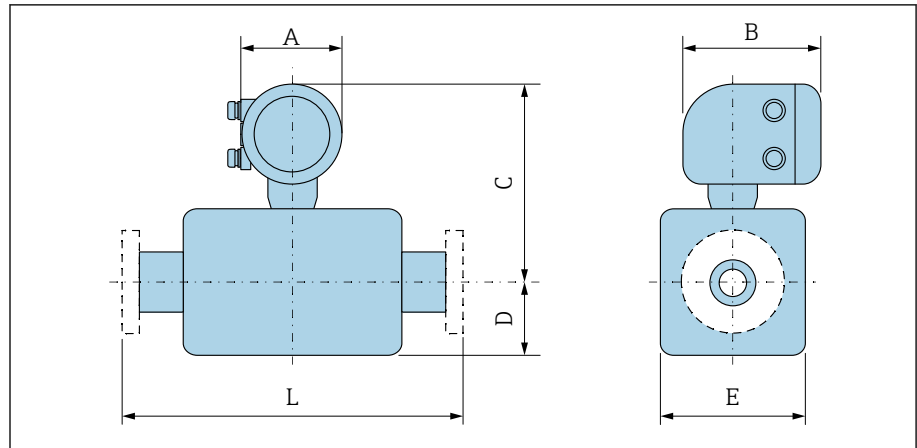

A0042708

DN		A ¹⁾	B	C ²⁾	D	E	L ³⁾
[mm]	[in]	[in]	[in]	[in]	[in]	[in]	[in]
15	½	5.2	6.77	10.04	3.31	4.72	7.87
25	1	5.2	6.77	10.04	3.31	4.72	7.87
32	–	5.2	6.77	10.04	3.31	4.72	7.87
40	1 ½	5.2	6.77	10.04	3.31	4.72	7.87
50	2	5.2	6.77	10.04	3.31	4.72	7.87
65	–	5.2	6.77	11.02	4.29	7.09	7.87
80	3	5.2	6.77	11.02	4.29	7.09	7.87
100	4	5.2	6.77	11.02	4.29	7.09	9.84
125	–	5.2	6.77	12.6	5.91	10.24	9.84
150	6	5.2	6.77	12.6	5.91	10.24	11.81
200	8	5.2	6.77	13.58	7.09	12.76	13.78
250	10	5.2	6.77	14.57	8.07	15.75	17.72
300	12	5.2	6.77	15.55	9.06	18.11	19.69
350	14	5.2	6.77	17.87	11.1	22.2	21.65
400	16	5.2	6.77	18.9	12.13	24.25	23.62
450	18	5.2	6.77	19.88	13.11	26.22	25.59
500	20	5.2	6.77	20.87	14.13	28.23	25.59
600	24	5.2	6.77	22.95	16.18	32.32	30.71

- 1) Depending on the cable gland used: values up to +1.18 in
- 2) With order code for "Sensor option", option CG "Sensor extended neck for insulation": values +4.33 in
- 3) Total installed length is independent of the process connections. Installed length according to DVGW (German Technical and Scientific Association for Gas and Water).

Remote version

Transmitter remote version

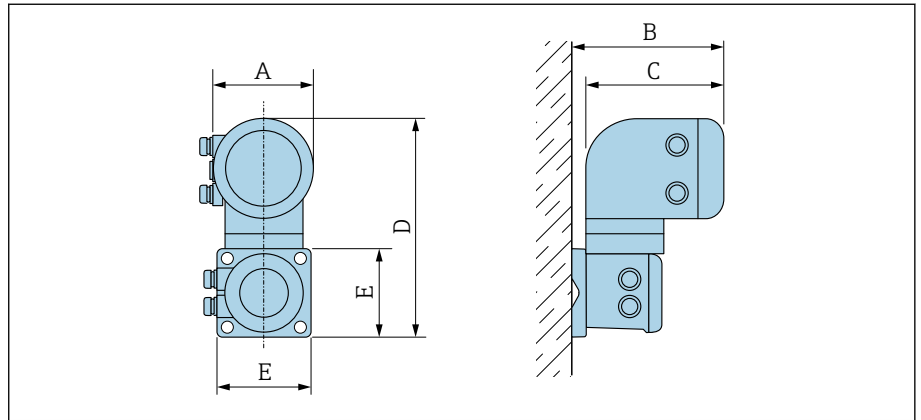

A0042715

Order code for "Housing"	A ¹⁾ [in]	B [in]	C [in]	D [in]	E [in]
Option N "Remote, polycarbonate"	5.2	7.36	6.77	12.09	5.12
Option P and T "Remote, coated aluminum"	5.47	7.28	7.01	12.17	5.12

1) Depending on the cable entry used: values up to +1.18 in

Sensor remote version

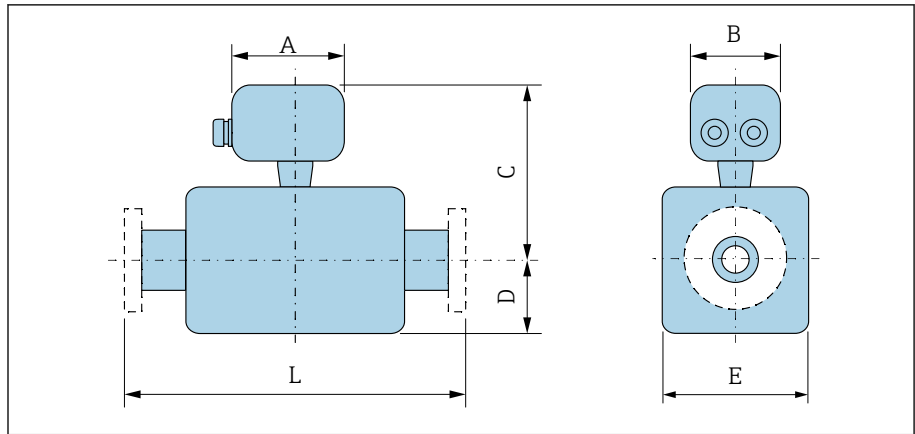

A0042718

DN		A ¹⁾	B	C ²⁾	D	E	L ³⁾
[mm]	[in]	[in]	[in]	[in]	[in]	[in]	[in]
15	½	5.83	5.35	7.76	3.31	4.72	7.87
25	1	5.83	5.35	7.76	3.31	4.72	7.87
32	–	5.83	5.35	7.76	3.31	4.72	7.87
40	1 ½	5.83	5.35	7.76	3.31	4.72	7.87
50	2	5.83	5.35	7.76	3.31	4.72	7.87
65	–	5.83	5.35	8.74	4.29	7.09	7.87
80	3	5.83	5.35	8.74	4.29	7.09	7.87
100	4	5.83	5.35	8.74	4.29	7.09	9.84
125	–	5.83	5.35	10.31	5.91	10.24	9.84
150	6	5.83	5.35	10.31	5.91	10.24	11.81
200	8	5.83	5.35	11.3	7.09	12.76	13.78
250	10	5.83	5.35	12.28	8.07	15.75	17.72
300	12	5.83	5.35	13.27	9.06	18.11	19.69
350	14	5.83	5.35	15.59	11.1	22.2	21.65
400	16	5.83	5.35	16.61	12.13	24.25	23.62
450	18	5.83	5.35	17.6	13.11	26.22	25.59
500	20	5.83	5.35	18.58	14.13	28.23	25.59
600	24	5.83	5.35	20.67	16.18	32.32	30.71

- 1) Depending on the cable gland used: values up to +1.18 in
- 2) With order code for "Sensor option", option CG "Sensor extended neck for insulation" or order code for "Liner", option B "PFA high temperature": values +4.33 in
- 3) Total installed length is independent of the process connections. Installed length according to DVGW (German Technical and Scientific Association for Gas and Water).

Fixed flange

Flange similar to ASME B16.5, Class 150

- Carbon steel: order code for "Process connection", option A1K
- Stainless steel: order code for "Process connection", option A1S

Surface roughness: Ra 250 to 492 µin

E: Internal diameter depends on the liner → *Measuring pipe specification*, 106

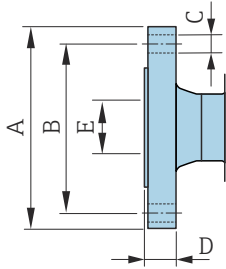

A0041915

DN [in]	A [in]	B [in]	C [in]	D [in]
½	3.50	2.38	4 × Ø0.63	0.38
1	4.25	3.12	4 × Ø0.63	0.5
1 ½	5	3.88	4 × Ø0.63	0.63
2	6	4.75	4 × Ø0.75	0.69
3	7.5	6	4 × Ø0.75	0.88
4	9	7.5	8 × Ø0.75	0.88
6	11	9.5	8 × Ø0.88	0.94
8	13.5	11.75	8 × Ø0.88	1.06
10	16	14.25	12 × Ø1	1.17
12	19	17	12 × Ø1	1.19
14	21.06	18.75	12 × Ø1.13	1.39
16	23.43	21.25	16 × Ø1.13	1.46
18	25	22.75	16 × Ø1.25	1.58
20	27.56	25	20 × Ø1.25	1.7
24	32.09	29.5	20 × Ø1.37	1.89

Flange similar to ASME B16.5, Class 300

- Carbon steel: order code for "Process connection", option A2K
- Stainless steel: order code for "Process connection", option A2S

Surface roughness: Ra 250 to 492 µin

E: Internal diameter depends on the liner → *Measuring pipe specification*, 106

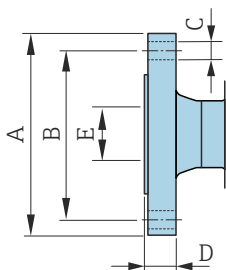

A0041915

DN [in]	A [in]	B [in]	C [in]	D [in]
½	3.75	2.62	4 × Ø0.63	0.50
1	4.88	3.5	4 × Ø0.75	0.63
1 ½	6.12	4.5	4 × Ø0.88	0.75
2	6.5	5	8 × Ø0.75	0.82
3	8.25	6.62	8 × Ø0.88	1.06
4	10	7.88	8 × Ø0.88	1.19
6	12.5	10.62	12 × Ø0.88	1.38

Lap joint flange

Lap joint flange similar to ASME B16.5, Class 150

- **Carbon steel:** order code for "Process connection", option A12
- **Stainless steel:** order code for "Process connection", option A14

Surface roughness (flange): Ra 248 to 492 µin

F: Internal diameter depends on the liner → *Measuring pipe specification*,  106

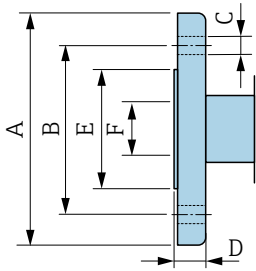

A0042254

DN [in]	A [in]	B [in]	C [in]	D [in]	E [in]
1	4.33	3.15	4 × Ø0.63	0.55	1.93
1 ½	4.92	3.86	4 × Ø0.63	0.69	2.8
2	5.91	4.76	4 × Ø0.75	0.75	3.46
3	7.48	5.98	4 × Ø0.75	0.94	4.72
4	9.06	7.48	8 × Ø0.75	0.94	5.83
6	11.02	9.49	8 × Ø0.91	0.98	8.23
8	13.58	11.73	8 × Ø0.91	1.14	10.39
10	15.94	14.25	12 × Ø0.98	1.18	12.48
12	19.09	17.01	12 × Ø0.98	1.26	14.88

Accessories

Weather protection cover

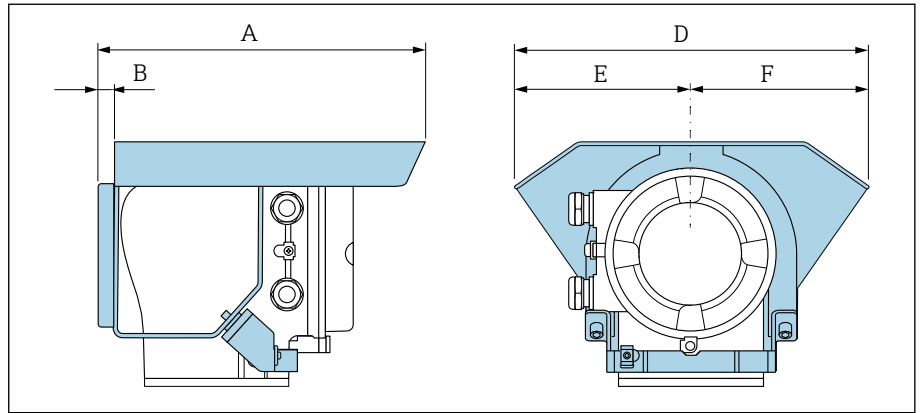

A0042332

A [in]	B [in]	D [in]	E [in]	F [in]
10.12	0.47	11.02	5.51	5.51

Ground disks for flanges

DN 15 to 300 (½ to 12")		DN	Pressure rating	A	B	C ¹⁾	D	E	F
		[mm]	[in]	[in]	[in]	[in]	[in]	[in]	[in]
	15	½"	2)	2.87	0.26	0.08	0.63	1.69	2.42
	25	1"	2)	3.44	0.26	0.08	1.02	2.44	3.05
	32	1 ¼"	2)	3.72	0.26	0.08	1.38	3.15	3.44
	40	1 ½"	2)	4.06	0.26	0.08	1.61	3.23	3.98
	50	2"	2)	4.25	0.26	0.08	2.05	3.98	4.55
	65	2 ½"	2)	4.65	0.26	0.08	2.68	4.76	5.18
	80	3"	2)	5.31	0.26	0.08	3.15	5.16	6.08
	100	4"	2)	6.02	0.26	0.08	4.09	6.14	7.34
	125	5"	2)	6.3	0.26	0.08	5.12	7.36	8.13
	150	6"	2)	7.24	0.26	0.08	6.22	8.54	10.08
	200	8"	2)	8.07	0.26	0.08	8.11	10.51	11.34
	250	10"	2)	9.45	0.26	0.08	10.24	12.91	14.13
300	12"		PN 10 PN 16 Cl. 150	10.75	0.26	0.08	12.28	14.76	16.26

A0042332

- 1) Material thickness
- 2) In the case of DN ½ to 10", ground disks can be used for all the flange standards/pressure ratings which can be supplied in the standard version.

DN 300 to 600 (12 to 24")	DN		Rating	A	B	C ¹⁾	D	E	F
	[mm]	[in]							
	300	12"	PN 25 JIS 10K JIS 20K	10.55	0.35	0.08	12.2	14.76	15.91
	350	14"	PN 6 PN 10 PN 16	14.37	0.35	0.08	13.5	16.54	18.86
	375	15"	PN 16	15.55	0.35	0.08	15.47	18.15	20.59
	400	16"	PN 6 PN 10 PN 16	15.55	0.35	0.08	15.47	18.5	21.34
	450	18"	PN 6 PN 10 PN 16	16.42	0.35	0.08	17.28	20.67	22.95
	500	20"	PN 6 PN 10 PN 16	18.11	0.35	0.08	19.41	22.64	25.59
	600	24"	PN 6 PN 10 PN 16	20.55	0.35	0.08	23.35	26.61	30.16

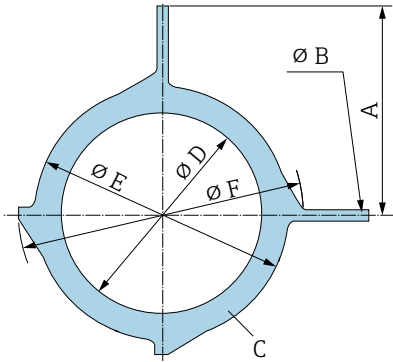



1) Material thickness

16 Accessories

Device-specific accessories	146
Communication-specific accessories	147
Service-specific accessory	147
System components	148

Device-specific accessories





Transmitter

Accessories	Description	Order number
Proline 10 transmitter	 Installation Instructions EA01350D	5XBBXX-*...*
Weather protection cover	Protects the device from weather exposure:  Installation Instructions EA01351D	71502730
Connecting cable	Can be ordered with the device. The following cable lengths are available: order code for "Cable, sensor connection" <ul style="list-style-type: none"> ▪ 5 m (16 ft) ▪ 10 m (32 ft) ▪ 20 m (65 ft) ▪ User-configurable cable length m (ft)  Max. cable length: 200 m (660 ft)	DK5013-*...*
Ground cable	1 ground cable set for potential equalization, consisting of 2 ground cables	

Sensor



Accessories	Description
Ground disks	Ground medium in lined measuring pipes.  Installation Instructions EA00070D

Communication-specific accessories



Accessory	Description
Commubox FXA291	Connects the Endress+Hauser devices with the CDI interface (= Endress+Hauser Common Data Interface) to the USB interface of a personal computer or laptop.  Technical Information TI405C/07
Field Xpert SMT50	The Field Xpert SMT50 table PC for device configuration enables mobile plant asset management. It is suitable for commissioning and maintenance staff to manage field instruments with a digital communication interface and to record progress. This tablet PC is designed as an all-in-one solution with a preinstalled driver library and is an easy-to-use, touch-sensitive tool which can be used to manage field instruments throughout their entire life cycle.  <ul style="list-style-type: none"> ▪ Technical Information TI01555S ▪ Operating Instructions BA02053S ▪ Product page: www.endress.com/smt50
Field Xpert SMT70	Tablet PC for the configuration of the device. Enables mobile Plant Asset Management to manage the devices with a digital communication interface. Suitable for Zone 2.  <ul style="list-style-type: none"> ▪ Technical Information TI01342S ▪ Operating Instructions BA01709S ▪ Product page: www.endress.com/smt70
Field Xpert SMT77	Tablet PC for the configuration of the device. Enables mobile Plant Asset Management to manage the devices with a digital communication interface. Suitable for Zone 1.  <ul style="list-style-type: none"> ▪ Technical Information TI01418S ▪ Operating Instructions BA01923S ▪ Product page: www.endress.com/smt77
FieldPort SFP20	The FieldPort SFP20 is a USB interface for the configuration of Endress+Hauser IO-Link devices, and also of devices from other vendors. Combined with the IO-Link CommDTM (DeviceCare, FieldCare, Field Xpert) and the IODD Interpreter, the FieldPort complies with the FDT/DTM standards.
IO-Link master BL20	IO-Link master from Turck for DIN rails supports PROFINET, EtherNet/IP and Modbus TCP. With web server for easy configuration.

Service-specific accessory

Accessory	Description	Order code
Applicator	Software for selecting and sizing Endress+Hauser devices.	https://portal.endress.com/webapp/applicator
Netilion	IIoT ecosystem: Unlock knowledge With the Netilion IIoT ecosystem, Endress+Hauser allows you to optimize your plant performance, digitize workflows, share knowledge, and enhance collaboration. Based on decades of experience in process automation, Endress+Hauser offers the process industry an IIoT ecosystem that enables you to gain useful insights from data. These insights can be used to optimize processes, leading to increased plant availability, efficiency, and reliability - ultimately resulting in a more profitable plant.	www.netilion.endress.com

Accessory	Description	Order code
FieldCare	FDT-based plant asset management software from Endress+Hauser. Management and configuration of Endress+Hauser devices.  Operating Instructions BA00027S and BA00059S	<ul style="list-style-type: none"> ▪ Device driver: www.endress.com → Download Area ▪ CD-ROM (contact Endress+Hauser) ▪ DVD (contact Endress+Hauser)
DeviceCare	Software for connecting and configuring Endress+Hauser devices.  <ul style="list-style-type: none"> ▪ Technical Information: TI01134S ▪ Innovation brochure: IN01047S 	<ul style="list-style-type: none"> ▪ Device driver: www.endress.com → Download Area ▪ CD-ROM (contact Endress+Hauser) ▪ DVD (contact Endress+Hauser)

System components

Accessories	Description
Memograph M	Graphic data manager: <ul style="list-style-type: none"> ▪ Record measured values ▪ Monitor limit values ▪ Analyze measuring points  <ul style="list-style-type: none"> ▪ Technical Information TI00133R ▪ Operating Instructions BA00247R
iTEMP	Temperature transmitter: <ul style="list-style-type: none"> ▪ Measure the absolute pressure and gauge pressure of gases, vapors and liquids ▪ Read the medium temperature  "Fields of Activity" document FA00006T

17 Appendix

Screw tightening torques	151
Examples of electric terminals	158





Screw tightening torques

General notes

Note the following for the screw tightening torques:

- Only for lubricated threads.
- Only for pipes that are free from tensile stress.
- Tighten the screws uniformly and in diagonally opposite sequence.
- Overtightening the screws will deform the sealing surface or damage the seal.
- Maximum or nominal screw tightening torques apply depending on the flange standard and size.

Max. screw tightening torques

EN 1092-1: DN 25 to 600	→ <i>Max. screw tightening torques for EN 1092-1</i> ,  153
ASME B16.5	→ <i>Max. screw tightening torques for ASME B16.5</i> ,  154
JIS B2220: DN 25 to 300	→ <i>Max. screw tightening torques for JIS B2220</i> ,  155
AS 2129, Table E	→ <i>Max. screw tightening torques for AS 2129, Table E</i> ,  155
AS 4087, PN 16	→ <i>Max. screw tightening torques for AS 4087, PN 16</i> ,  156

Nominal screw tightening torques

JIS B2220: DN 350 to 750	→ <i>Nominal screw tightening torques for JIS B2220</i> ,  157
--------------------------	--

Maximum screw tightening torques

Max. screw tightening torques for EN 1092-1

Nominal diameter		Pressure rating [bar]	Screws [mm]	Flange thickness [mm]	Max. screw tightening torque [Nm]		
[mm]	[in]				HR	PUR	PTFE
25	1	PN 40	4×M12	18	-	15	26
32	-	PN 40	4×M16	18	-	24	41
40	1 ½	PN 40	4×M16	18	-	31	52
50	2	PN 40	4×M16	20	48	40	65
65 ¹⁾	-	PN 16	8×M16	18	32	27	44
65	-	PN 40	8×M16	22	32	27	44
80	3	PN 16	8×M16	20	40	34	53
		PN 40	8×M16	24	40	34	53
100	4	PN 16	8×M16	20	43	36	57
		PN 40	8×M20	24	59	50	79
125	-	PN 16	8×M16	22	56	48	75
		PN 40	8×M24	26	83	71	112
150	6	PN 16	8×M20	22	74	63	99
		PN 40	8×M24	28	104	88	137
200	8	PN 10	8×M20	24	106	91	141
		PN 16	12×M20	24	70	61	94
		PN 25	12×M24	30	104	92	139
250	10	PN 10	12×M20	26	82	71	110
		PN 16	12×M24	26	98	85	132
		PN 25	12×M27	32	150	134	201
300	12	PN 10	12×M20	26	94	81	126
		PN 16	12×M24	28	134	118	179
		PN 25	16×M27	34	153	138	204
350	14	PN 6	12×M20	22	111	120	-
		PN 10	16×M20	26	112	118	-
		PN 16	16×M24	30	152	165	-
		PN 25	16×M30	38	227	252	-
400	16	PN 6	16×M20	22	90	98	-
		PN 10	16×M24	26	151	167	-
		PN 16	16×M27	32	193	215	-
		PN 25	16×M33	40	289	326	-
450	18	PN 6	16×M20	22	112	126	-
		PN 10	20×M24	28	153	133	-
		PN 16	20×M27	40	198	196	-
		PN 25	20×M33	46	256	253	-
500	20	PN 6	20×M20	24	119	123	-
		PN 10	20×M24	28	155	171	-
		PN 16	20×M30	34	275	300	-
		PN 25	20×M33	48	317	360	-

Nominal diameter		Pressure rating	Screws	Flange thickness	Max. screw tightening torque [Nm]		
[mm]	[in]				[bar]	[mm]	HR
600	24	PN 6	20×M24	30	139	147	–
		PN 10	20×M27	28	206	219	–
600	24	PN 16	20×M33	36	415	443	–
600	24	PN 25	20×M36	58	431	516	–

Abbreviations (liner): HR = hard rubber, PUR = polyurethane

1) Design in accordance with EN 1092-1

Max. screw tightening torques for EN 1092-1

Nominal diameter		Pressure rating	Screws	Flange thickness	Max. screw tightening torque [Nm]		
[mm]	[in]				[bar]	[mm]	HR
25	1	PN 40	4×M12	18	–	15	26
32	–	PN 40	4×M16	18	–	24	41
40	1 ½	PN 40	4×M16	18	–	31	52
50	2	PN 40	4×M16	20	48	40	65
65 ¹⁾	–	PN 16	8×M16	18	32	27	44
65	–	PN 40	8×M16	22	32	27	44
80	3	PN 16	8×M16	20	40	34	53
		PN 40	8×M16	24	40	34	53
100	4	PN 16	8×M16	20	43	36	57
		PN 40	8×M20	24	59	50	79
125	–	PN 16	8×M16	22	56	48	75
		PN 40	8×M24	26	83	71	112
150	6	PN 16	8×M20	22	74	63	99
		PN 40	8×M24	28	104	88	137
200	8	PN 10	8×M20	24	106	91	141
		PN 16	12×M20	24	70	61	94
		PN 25	12×M24	30	104	92	139
250	10	PN 10	12×M20	26	82	71	110
		PN 16	12×M24	26	98	85	132
		PN 25	12×M27	32	150	134	201
300	12	PN 10	12×M20	26	94	81	126
		PN 16	12×M24	28	134	118	179
		PN 25	16×M27	34	153	138	204
350	14	PN 6	12×M20	22	111	120	–
		PN 10	16×M20	26	112	118	–
		PN 16	16×M24	30	152	165	–
		PN 25	16×M30	38	227	252	–

Nominal diameter		Pressure rating [bar]	Screws [mm]	Flange thickness [mm]	Max. screw tightening torque [Nm]		
[mm]	[in]				HR	PUR	PTFE
400	16	PN 6	16×M20	22	90	98	-
		PN 10	16×M24	26	151	167	-
		PN 16	16×M27	32	193	215	-
		PN 25	16×M33	40	289	326	-
450	18	PN 6	16×M20	22	112	126	-
		PN 10	20×M24	28	153	133	-
		PN 16	20×M27	40	198	196	-
		PN 25	20×M33	46	256	253	-
500	20	PN 6	20×M20	24	119	123	-
		PN 10	20×M24	28	155	171	-
		PN 16	20×M30	34	275	300	-
		PN 25	20×M33	48	317	360	-
600	24	PN 6	20×M24	30	139	147	-
		PN 10	20×M27	28	206	219	-
600	24	PN 16	20×M33	36	415	443	-
600	24	PN 25	20×M36	58	431	516	-

Abbreviations (liner): HR = hard rubber, PUR = polyurethane

- 1) Design in accordance with EN 1092-1

Max. screw tightening torques for ASME B16.5

Nominal diameter		Pressure rating [psi]	Screws [in]	Max. screw tightening torque			
[mm]	[in]			HR	PUR		
				[Nm]	[lbf · ft]	[Nm]	[lbf · ft]
25	1	Class 150	4×½	-	-	7	5
25	1	Class 300	4×5/8	-	-	8	6
40	1 ½	Class 150	4×½	-	-	10	7
40	1 ½	Class 300	4×¾	-	-	15	11
50	2	Class 150	4×5/8	35	26	22	16
50	2	Class 300	8×5/8	18	13	11	8
80	3	Class 150	4×5/8	60	44	43	32
80	3	Class 300	8×¾	38	28	26	19
100	4	Class 150	8×5/8	42	31	31	23
100	4	Class 300	8×¾	58	43	40	30
150	6	Class 150	8×¾	79	58	59	44
150	6	Class 300	12×¾	70	52	51	38
200	8	Class 150	8×¾	107	79	80	59
250	10	Class 150	12×7/8	101	74	75	55
300	12	Class 150	12×7/8	133	98	103	76
350	14	Class 150	12×1	135	100	158	117
400	16	Class 150	16×1	128	94	150	111

Nominal diameter		Pressure rating [psi]	Screws [in]	Max. screw tightening torque			
[mm]	[in]			HR		PUR	
				[Nm]	[lbf · ft]	[Nm]	[lbf · ft]
450	18	Class 150	16×1 1/8	204	150	234	173
500	20	Class 150	20×1 1/8	183	135	217	160
600	24	Class 150	20×1 ¼	268	198	307	226

Abbreviations (liner): HR = hard rubber, PUR = polyurethane

Max. screw tightening torques for JIS B2220

Nominal diameter [mm]	Pressure rating [bar]	Screws [mm]	Max. screw tightening torque [Nm]	
			HR	PUR
25	10K	4×M16	–	19
25	20K	4×M16	–	19
32	10K	4×M16	–	22
32	20K	4×M16	–	22
40	10K	4×M16	–	24
40	20K	4×M16	–	24
50	10K	4×M16	40	33
50	20K	8×M16	20	17
65	10K	4×M16	55	45
65	20K	8×M16	28	23
80	10K	8×M16	29	23
80	20K	8×M20	42	35
100	10K	8×M16	35	29
100	20K	8×M20	56	48
125	10K	8×M20	60	51
125	20K	8×M22	91	79
150	10K	8×M20	75	63
150	20K	12×M22	81	72
200	10K	12×M20	61	52
200	20K	12×M22	91	80
250	10K	12×M22	100	87
250	20K	12×M24	159	144
300	10K	16×M22	74	63
300	20K	16×M24	138	124

Abbreviations (liner): HR = hard rubber, PUR = polyurethane

Max. screw tightening torques for AS 2129, Table E

Nominal diameter [mm]	Screws [mm]	Max. screw tightening torque [Nm]	
		HR	PUR
50	4×M16	32	–
80	4×M16	49	–

Nominal diameter [mm]	Screws [mm]	Max. screw tightening torque [Nm]	
		HR	PUR
100	8×M16	38	-
150	8×M20	64	-
200	8×M20	96	-
250	12×M20	98	-
300	12×M24	123	-
350	12×M24	203	-
400	12×M24	226	-
450	16×M24	226	-
500	16×M24	271	-
600	16×M30	439	-

Abbreviations (liner): HR = hard rubber, PUR = polyurethane

Max. screw tightening torques for AS 4087, PN 16

Nominal diameter [mm]	Screws [mm]	Max. screw tightening torque [Nm]	
		HR	PUR
50	4×M16	32	-
80	4×M16	49	-
100	4×M16	76	-
150	8×M20	52	-
200	8×M20	77	-
250	8×M20	147	-
300	12×M24	103	-
350	12×M24	203	-
375	12×M24	137	-
400	12×M24	226	-
450	12×M24	301	-
500	16×M24	271	-
600	16×M27	393	-

Abbreviations (liner): HR = hard rubber, PUR = polyurethane

Nominal screw tightening torques

Nominal screw tightening torques for JIS B2220

Nominal diameter [mm]	Pressure rating [bar]	Screws [mm]	Nominal screw tightening torque [Nm]	
			HR	PUR
350	10K	16×M22	109	109
	20K	16×M30×3	217	217
400	10K	16×M24	163	163
	20K	16×M30×3	258	258
450	10K	16×M24	155	155
	20K	16×M30×3	272	272
500	10K	16×M24	183	183
	20K	16×M30×3	315	315
600	10K	16×M30	235	235
	20K	16×M36×3	381	381

Abbreviations (liner): HR = hard rubber, PUR = polyurethane

Examples of electric terminals

IO-Link



See <https://io-link.com>"IO-Link System Description"

Index

A

- Adapting the diagnostic behavior 75
- Ambient conditions
 - Vibration resistance and shock resistance 97
- Ambient temperature range 97
- Applicator 88
- Approvals 110

C

- Certificates 110
- Certificates and approvals 110
- Check
 - Connection 51
 - Installation 37
- Checking the storage conditions (checklist) 21
- Checklist
 - Post-connection check 51
 - Post-installation check 37
- Commissioning 61, 62
 - see Commissioning wizard
 - see Via SmartBlue App
 - Switching on the device 63
- Commissioning the device 64
- Compatibility 24
- Conductivity 100
- Connecting cable terminal assignment
 - Sensor connection housing 43
- Connecting the connecting cable
 - Sensor connection housing 43
 - Transmitter connection housing 44

D

- Date of manufacture 17, 18
- Degree of protection 97
- Design
 - Device 22
- Device
 - Design 22
 - Disposal 86
 - Removal 86
- Device components 22
- Device description files 58
- Device history 24
- Device locking, status 66
- Device name
 - Sensor 18
 - Transmitter 17
- Diagnosis
 - Symbols 73
- Diagnostic information
 - Design, description 74
 - DeviceCare 74
 - FieldCare 74
 - LED 71
 - Local display 73
 - Overview 75

- Remedial measures 75
- Diagnostic information in FieldCare or DeviceCare . . . 74
- Diagnostic information via LED 71
- Diagnostic list 78
- Diagnostic message 73
- Display
 - Current diagnostic event 78
 - Previous diagnostic event 78
- Display values
 - For locking status 66
- Disposal 85
- Disposing of the device 86

E

- Electromagnetic compatibility 98
- Electronics module 22
- Endress+Hauser services
 - Maintenance 84
- Environmental conditions
 - Ambient temperature 97
 - Storage temperature 97
- Error messages
 - see Diagnostic messages
- Event logbook 78
- Events list 78
- Extended order code
 - Sensor 18
 - Transmitter 17

F

- Filtering the event logbook 79
- Firmware history 24
- Fitted electrodes 108
- Flow limit 100

G

- Galvanic isolation 91
- General troubleshooting 70
- Ground disks for flanges
 - Dimensions 133, 143

H

- HART protocol
 - Device variables 58
 - Dynamic variables 58

I

- Identifying the device 17
- Immersion in water 32
 - Installation conditions 32
- Incoming acceptance (checklist) 16
- Input 88
- Inspection
 - Received goods 16
- Intended use 16

L

- Local display
 - see Diagnostic message
 - see In alarm condition
- Low flow cut off 91

M

- Magnetism 32
- Magnetism and static electricity 32
- Main electronics module 22
- Maintenance tasks 84
- Materials 107
- Maximum measurement error 95
- Measured variable
 - see Process variables
- Measured variables via HART protocol 58
- Measuring pipe specification 106
- Measuring principle 16
- Measuring range 88
- Medium temperature range 99

N

- Nameplate
 - Sensor 18
 - Transmitter 17
- Non-Ex approval 110

O

- Operable flow range 88
- Operation 53, 65
- Order code 17, 18
- Output signal 90
- Output variables 90
- Overview of diagnostic information 75

P

- Packaging disposal 21
- Parameter settings
 - Device management (Submenu) 66
- Pending diagnostic events 78
- Performance characteristics 95
- Post-connection check 62
- Post-connection check (checklist) 51
- Post-installation check 62
- Post-installation check (checklist) 37
- Post-installation check and post-connection check . . . 62
- Potential equalization 46
- Pressure Equipment Directive 110
- Pressure loss 104
- Pressure tightness 103
- Pressure/temperature ratings 101
- Process conditions
 - Conductivity 100
 - Flow limit 100
 - Medium temperature 99
 - Pressure loss 104
 - Pressure tightness 103
 - Pressure/temperature ratings 101
- Product design 22

- Product identification 17

R

- Radio approval 110
- Reading off the device locking status 66
- Reading out the event logbook 78
- Recycling of packaging materials 21
- Reference operating conditions 95
- Registered trademarks 9
- Removing the device 86
- Repeatability 96
- Resetting the device
 - Settings 80

S

- Safety instructions 11
- Sensor nameplate 18
- Serial number 17, 18
- Services 84
- Signal on alarm 91
- SmartBlue App 64
- Standards and guidelines 111
- Static electricity 32
- Status signals 73
- Storage 21
- Storage conditions 21
- Storage temperature 21, 97
- Storage temperature range 97
- Submenu
 - Device management 66
 - Events list 78
- Surface roughness 108
- Switching on the device 63
- System design
 - see Device design
- System integration 57

T

- Temperature range
 - Storage temperature 21
- Tools
 - Transport 19
- Transmitter nameplate 17
- Transport
 - Transporting the device 19
- Troubleshooting
 - General 70

U

- Use in buried applications 32
 - Installation conditions 32
- Using the device
 - see Intended use

V

- Vibration resistance and shock resistance 97

W

- W@M Device Viewer 17

Weight
 Transport (notes) 19
Wiring the sensor connection housing 43
Wiring the transmitter housing 44



www.addresses.endress.com
