

Brief Operating Instructions

Liquisys M CCM223

Transmitter for free chlorine, chlorine dioxide and total chlorine







Table of contents









1	About this document	3
1.1	Warnings	3
1.2	Symbols used	3
1.3	Symbols on the device	3
2	Basic safety instructions	4
2.1	Requirements concerning personnel	4
2.2	Intended use	4
2.3	Workplace safety	4
2.4	Operational safety	5
2.5	Product safety	5
3	Incoming acceptance and product identification	5
3.1	Incoming acceptance	5
3.2	Scope of delivery	6
3.3	Product identification	6
4	Installation	8
4.1	Installation requirements	8
4.2	Installing the device	8
4.3	Post-installation check	9
5	Electrical connection	10
5.1	Connecting the device	10
5.2	Electrical connection, version 1	10
5.3	Electrical connection, version 2	12
5.4	Device connection	14
5.5	Measuring cables and sensor connection	15
5.6	Alarm contact	19
5.7	Post-connection check	20
6	Operation options	20
6.1	Overview of operation options	20
6.2	Display and operating elements	21
6.3	Access to operating menu via onsite display	25
7	Commissioning	28
7.1	Function check	28
7.2	Switching on the device	28
7.3	Quick start guide	29

1 About this document

1.1 Warnings

Structure of information	Meaning
<p> DANGER</p> <p>Causes (/consequences) If necessary, Consequences of non-compliance (if applicable)</p> <ul style="list-style-type: none"> ▶ Corrective action 	<p>This symbol alerts you to a dangerous situation. Failure to avoid the dangerous situation will result in a fatal or serious injury.</p>
<p> WARNING</p> <p>Causes (/consequences) If necessary, Consequences of non-compliance (if applicable)</p> <ul style="list-style-type: none"> ▶ Corrective action 	<p>This symbol alerts you to a dangerous situation. Failure to avoid the dangerous situation can result in a fatal or serious injury.</p>
<p> CAUTION</p> <p>Causes (/consequences) If necessary, Consequences of non-compliance (if applicable)</p> <ul style="list-style-type: none"> ▶ Corrective action 	<p>This symbol alerts you to a dangerous situation. Failure to avoid this situation can result in minor or more serious injuries.</p>
<p> NOTICE</p> <p>Cause/situation If necessary, Consequences of non-compliance (if applicable)</p> <ul style="list-style-type: none"> ▶ Action/note 	<p>This symbol alerts you to situations which may result in damage to property.</p>

1.2 Symbols used

	Additional information, tips
	Permitted
	Recommended
	Not permitted or not recommended
	Reference to device documentation
	Reference to page
	Reference to graphic
	Result of an individual step

1.3 Symbols on the device

	Reference to device documentation
	Do not dispose of products bearing this marking as unsorted municipal waste. Instead, return them to the manufacturer for disposal under the applicable conditions.

2 Basic safety instructions

2.1 Requirements concerning personnel

- Installation, commissioning, operation and maintenance of the measuring system may be carried out only by specially trained technical personnel.
- The technical personnel must be authorized by the plant operator to carry out the specified activities.
- The electrical connection may be performed only by an electrical technician.
- The technical personnel must have read and understood these Operating Instructions and must follow the instructions contained therein.
- Faults at the measuring point may only be rectified by authorized and specially trained personnel.



Repairs not described in the Operating Instructions provided must be carried out only directly at the manufacturer's site or by the service organization.

2.2 Intended use

The Liquisys M CCM223/253 transmitter is used to determine the amount of free chlorine, chlorine dioxide or total chlorine dissolved in water.

The transmitter is particularly suited for use in the following areas:

- Drinking water
- Water treatment
- Cooling water
- Gas scrubbers
- Reverse osmosis
- Food processing
- Swimming pool and bathing pool water

Any use other than that intended puts the safety of people and the measuring system at risk. Therefore, any other use is not permitted.

The manufacturer is not liable for harm caused by improper or unintended use.

2.3 Workplace safety

The operator is responsible for ensuring compliance with the following safety regulations:

- Installation guidelines
- Local standards and regulations

Electromagnetic compatibility

- The product has been tested for electromagnetic compatibility in accordance with the applicable international standards for industrial applications.
- The electromagnetic compatibility indicated applies only to a product that has been connected in accordance with these Operating Instructions.

2.4 Operational safety

Before commissioning the entire measuring point:

1. Verify that all connections are correct.
2. Ensure that electrical cables and hose connections are undamaged.

Procedure for damaged products:

1. Do not operate damaged products, and protect them against unintentional operation.
2. Label damaged products as defective.

During operation:

- ▶ If errors cannot be rectified, take products out of service and protect them against unintentional operation.

2.5 Product safety

2.5.1 State of the art

The product is designed to meet state-of-the-art safety requirements, has been tested, and left the factory in a condition in which it is safe to operate. The relevant regulations and international standards have been observed.

2.5.2 IT security

We only provide a warranty if the device is installed and used as described in the Operating Instructions . The device is equipped with security mechanisms to protect it against any inadvertent changes to the device settings.

IT security measures in line with operators' security standards and designed to provide additional protection for the device and device data transfer must be implemented by the operators themselves.

3 Incoming acceptance and product identification

3.1 Incoming acceptance

On receipt of the delivery:

1. Check the packaging for damage.
 - ↳ Report all damage immediately to the manufacturer.
Do not install damaged components.
2. Check the scope of delivery using the delivery note.
3. Compare the data on the nameplate with the order specifications on the delivery note.

4. Check the technical documentation and all other necessary documents, e.g. certificates, to ensure they are complete.



If one of the conditions is not satisfied, contact the manufacturer.

3.2 Scope of delivery

- 1 transmitter
- 1 set of plug-in screw terminals
- 2 tensioning screws
- Also for EP version: 1 BNC connector (solder-free)
- 1 set of Brief Operating Instructions
- For versions with HART communication:
 - 1 set of Operating Instructions: Field communication with HART
- For versions with PROFIBUS interface:
 - 1 set of Operating Instructions: Field communication with PROFIBUS PA/DP

3.3 Product identification

3.3.1 Manufacturer address

Endress+Hauser Conducta GmbH+Co. KG
Dieselstraße 24
70839 Gerlingen
Germany

Interpreting the order code

The order code and serial number of your product can be found in the following locations:

- On the nameplate
- In the delivery papers

Obtaining information on the product

1. Go to www.endress.com.
2. Page search (magnifying glass symbol): Enter valid serial number.
3. Search (magnifying glass).
 - ↳ The product structure is displayed in a popup window.
4. Click the product overview.
 - ↳ A new window opens. Here you will find information pertaining to your device, including the product documentation.

3.3.2 Product page

www.endress.com/CCM223

3.3.3 Nameplate

The following information on the device can be found on the nameplate:

- Manufacturer identification
- Order code
- Extended order code
- Serial number
- Ambient and process conditions
- Input and output values
- Safety information and warnings

► Compare the information on the nameplate with the order.

3.3.4 Product identification

The order code and serial number of your product can be found in the following locations:

- On the nameplate
- In the delivery papers

Obtaining information on the product

1. Go to www.endress.com.
2. Page search (magnifying glass symbol): Enter valid serial number.
3. Search (magnifying glass).
 - ↳ The product structure is displayed in a popup window.
4. Click the product overview.
 - ↳ A new window opens. Here you will find information pertaining to your device, including the product documentation.

4 Installation

4.1 Installation requirements

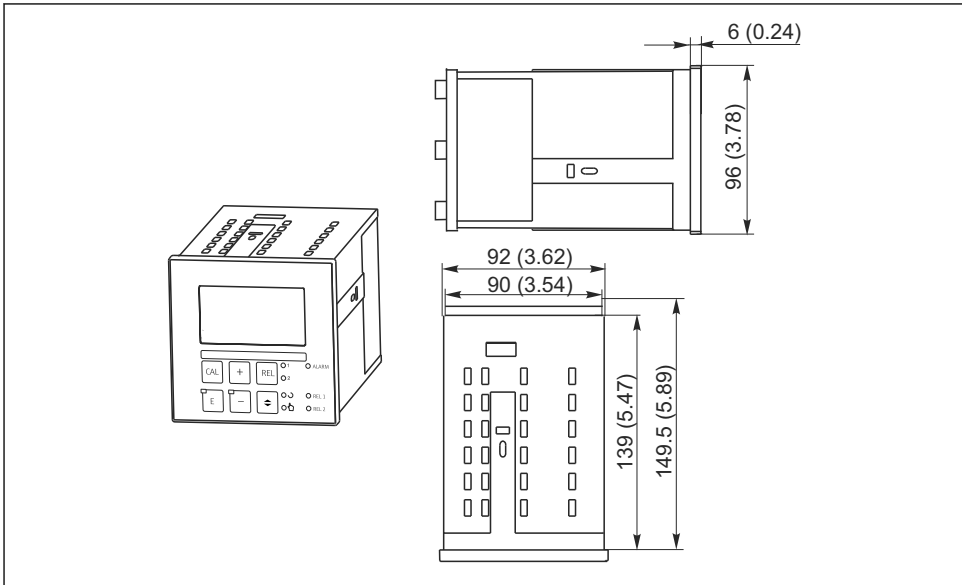

A0024641

☛ 1 Panel-mounted device, dimensions in mm (in)

4.2 Installing the device

The panel-mounted device is secured with the tensioning screws supplied → ☛ 2

The necessary installation depth is approx. 165 mm (6.50").

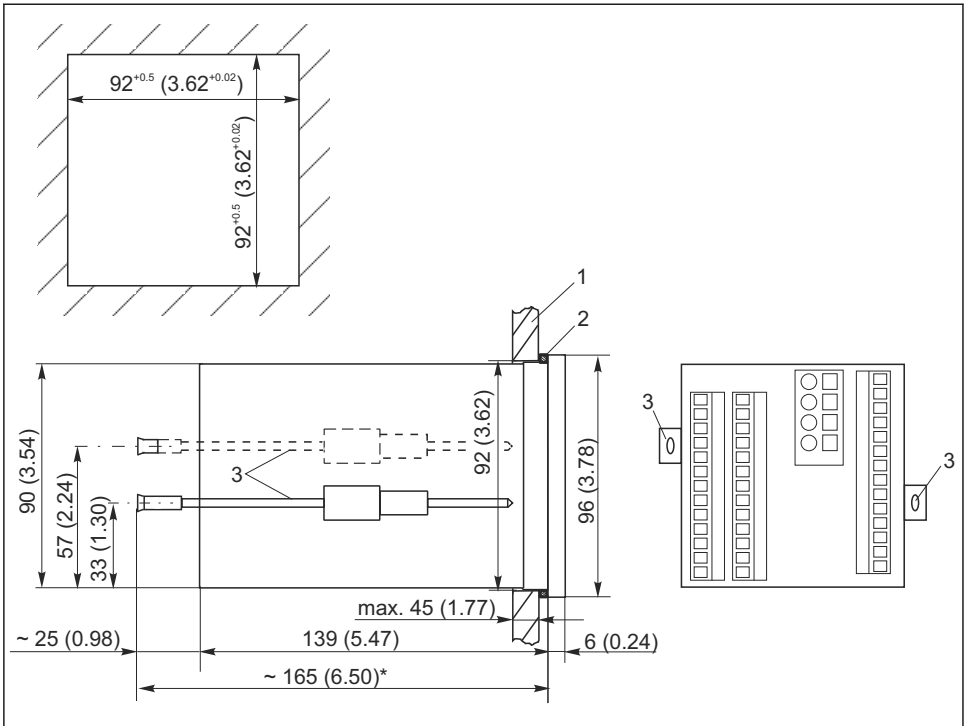

A0024639

2 Dimensions in mm (inch)

1 Mounting plate

2 Seal

3 Tensioning screws

* Necessary installation depth

4.3 Post-installation check

- After installation, check the transmitter for damage.
- Check whether the transmitter is protected against precipitation and direct sunlight

5 Electrical connection

⚠ WARNING

Device is live!

Incorrect connection may result in injury or death!

- ▶ The electrical connection may be performed only by an electrical technician.
- ▶ The electrical technician must have read and understood these Operating Instructions and must follow the instructions contained therein.
- ▶ **Prior** to commencing connection work, ensure that no voltage is present on any cable.

5.1 Connecting the device

⚠ WARNING

Risk of electric shock!

- ▶ At the supply point, the power supply must be isolated from dangerous live cables by double or reinforced insulation in the case of devices with a 24 V power supply.

NOTICE

The device does not have a power switch

- ▶ A protected circuit breaker must be provided in the vicinity of the device at the place of installation.
- ▶ The circuit breaker must be a switch or power switch, and you must label it as the circuit breaker for the device.

The electrical connection of the transmitter depends on the sensor:

- If using the CCS140/141/240/241 membrane-covered sensor, follow the instructions and illustrations in the "Electrical connection, version 1" section.
- If using the CCS120 total chlorine sensor, follow the instructions and illustrations in the "Electrical connection, version 2" section.

5.2 Electrical connection, version 1

The wiring diagram shows the connections of a device equipped with all the options. The connection of the sensors to the various measuring cables is explained in more detail in the "Measuring cables and sensor connection" section.

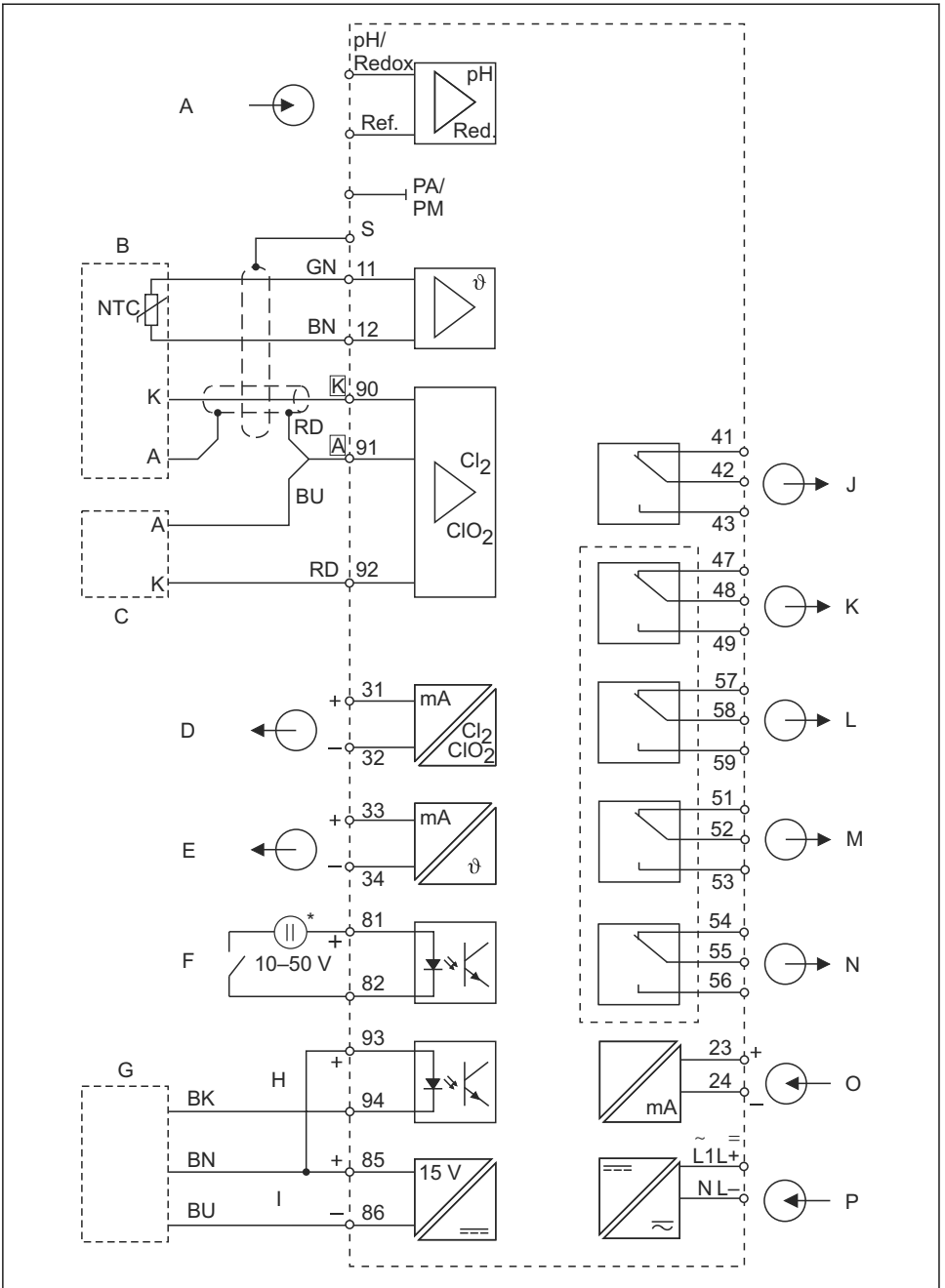

A0001903

3 Electrical connection of the transmitter (version 1)

A	<i>pH/ORP input (optional)</i>	I	<i>Auxiliary voltage output</i>
B	<i>Sensor CCS140/141/240/241</i>	J	<i>Alarm (current-free contact position)</i>
C	<i>Sensor (alternative)</i>	K	<i>Relay 1 (current-free contact position)</i>
D	<i>Signal output 1, chlorine / chlorine dioxide</i>	L	<i>Relay 2 (current-free contact position)</i>
E	<i>Signal output 2, temperature, pH or ORP</i>	M	<i>Relay 3 (current-free contact position)</i>
F	<i>Binary input 1 (hold/cleaning)</i>	N	<i>Relay 4 (current-free contact position)</i>
G	<i>Proximity switch INS</i>	O	<i>Current input 4 to 20 mA</i>
H	<i>Binary input 2</i>	P	<i>Power supply</i>
*	<i>Auxiliary voltage of terminal 85/86 can be used</i>		

 The device is approved for protection class II and is generally operated without a protective ground connection. Circuits "E" and "I" are not galvanically isolated from each other.

5.3 Electrical connection, version 2

The wiring diagram shows the connections of a device equipped with all the options. The connection of the sensors to the various measuring cables is explained in more detail in the "Measuring cables and sensor connection" section.

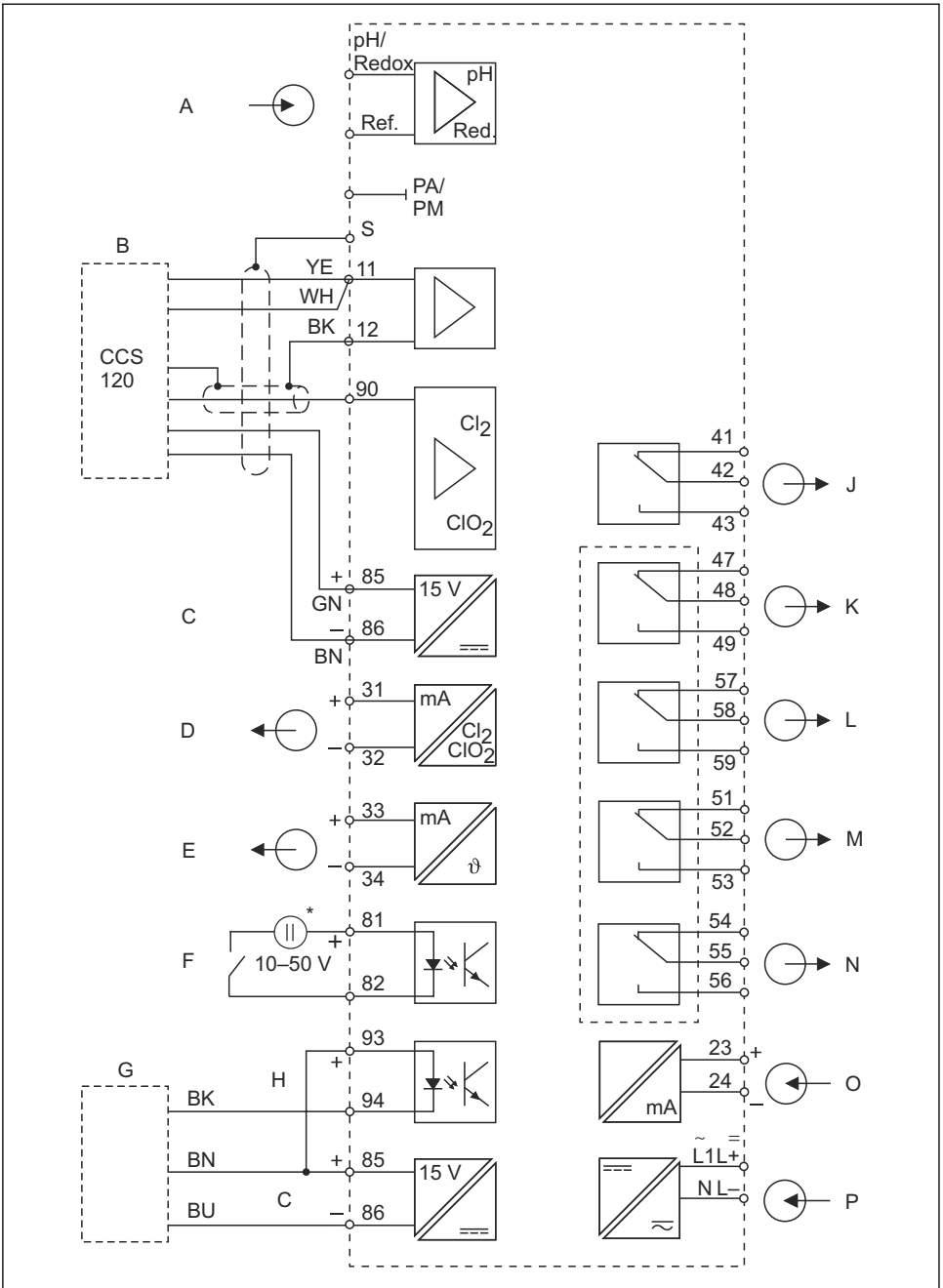

A0001904

4 Electrical connection of the transmitter (version 2)

- | | | | |
|---|---|---|---|
| A | pH/ORP input (optional) | * | Auxiliary voltage of terminal 85/86 can be used |
| B | Sensor CCS120 | J | Alarm (current-free contact position) |
| C | Auxiliary voltage output | K | Relay 1 (current-free contact position) |
| D | Signal output 1, total chlorine | L | Relay 2 (current-free contact position) |
| E | Signal output 2, temperature, pH or ORP | M | Relay 3 (current-free contact position) |
| F | Binary input 1 (hold/cleaning) | N | Relay 4 (current-free contact position) |
| G | Proximity switch INS | O | Current input 4 to 20 mA |
| H | Binary input 2 | P | Power supply |

 The device is approved for protection class II and is generally operated without a protective ground connection. Circuits "E" and "C" are not galvanically isolated from each other.

5.4 Device connection

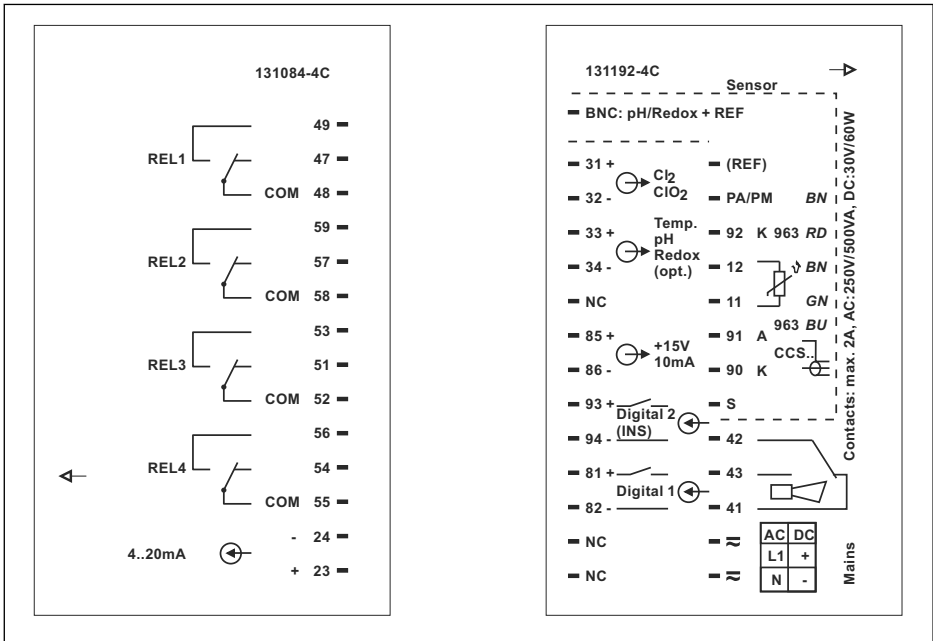

 5 Connection sticker

Connect the cables to the terminals at the rear of the device according to the terminal assignment.

NOTICE**Non-observance could cause incorrect measurement.**

- ▶ Protect the cable ends and terminals from moisture.
- ▶ Do not connect terminals marked NC.
- ▶ Do not connect terminals that are not marked.



Label the sensor terminal block with the sticker provided.

5.5 Measuring cables and sensor connection

Sensor type	Cable	Extension
Chlorine/chlorine dioxide sensors CCS140 / 141 / 240 / 241	3 m (9.8 ft) CMK, permanently connected	VBC box + CMK
Total chlorine sensor CCS120	CPK9-N*A1B	VBC box + CYK71
pH or ORP sensor without temperature sensor	CPK1 for sensors with GSA plug-in head CPK9 for sensors with ESA plug-in head	VBC box + CYK71

Connect the CCS140/141/240/241 chlorine sensors

The sensors are equipped with a 3 m (9.8 ft) fixed cable.

Connection diagram		
Assignment	Core	Transmitter terminal
Outer shield		S
Anode	A red	91
Cathode	K	90
NTC temperature sensor	Green	11
NTC temperature sensor	Brown	12

- ▶ Connect the sensors to the transmitter according to the connection diagram.

Connect CCS120 total chlorine sensors

Connection diagram			
Pin	Assignment	Core	Transmitter terminal
1	TC signal	Coax, inside (white)	90
2	AGND	Coax, outside (black)	12
3			
4	+UB (15 V)	Green	85
5	NTC1	yellow*	11

Connection diagram			
Pin	Assignment	Core	Transmitter terminal
	NTC1	white*	11
6	NTC2/AGND	Brown	86
S	Shield	S	S

* The white and yellow cores are interconnected in the TOP68 connector.

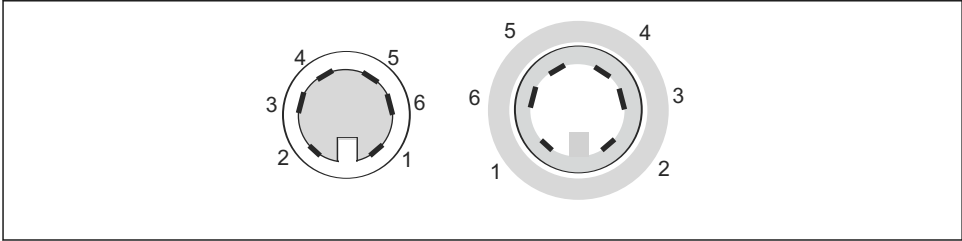

6 TOP68 connection; pin arrangement of connector and coupling (shown from contact side)

- ▶ Connect the sensor with the measuring cable CPK9-N*A1B (with internal PML) according to the following connection diagram.

Connect the pH sensor or ORP sensor

1. To avoid mutual interference between the various sensors installed in the CCA250 assembly, connect the sensor symmetrically.
2. If glass electrodes are used, terminate the measuring cable with a BNC connector. A solder-free BNC connector is supplied with the device.

Terminate the cable with the BNC connector

1.

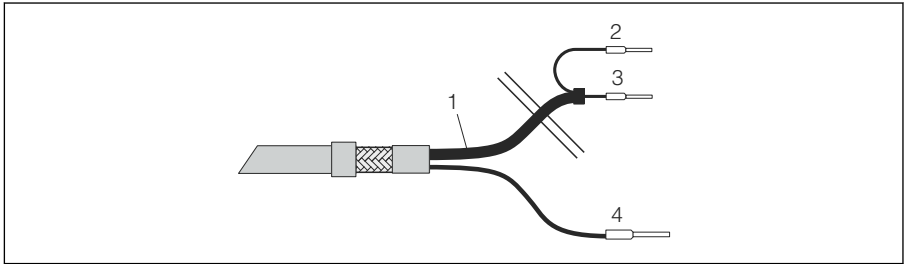

A0005744

7 Cable CPK1: device connection

- 1 Coax cable
- 2 Inner shield BK (ref)
- 3 Inner coax (pH / mV)
- 4 Strand BN (PA)

Cut off the end ferrules 2 and 3 of the coaxial cable.

2.

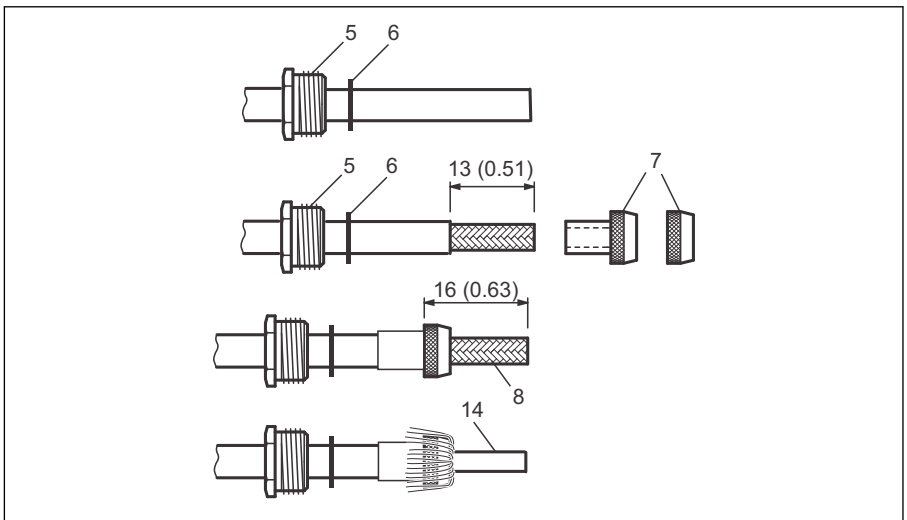

A0005745

8 Terminating the pH connecting cable for mounting the BNC elbow plug. Dimensions in mm (inch)

Slide the cable gland 5 and washer 6 over the coaxial cable.

3. Remove the insulation (13 mm (0.51")) and screw the clamping ring 7 on the insulation. Parts 5 to 7 are supplied with the BNC connector for cable diameters 3.2 mm and 5 mm.
4. Fold the braided shield 8 of the shield over the clamping ring and cut off the excess material.

5. There is a semiconductor layer 14 (conductive membrane) between the inner insulation and the braided shield 8. Strip this semiconductor layer as far as the braided shield.

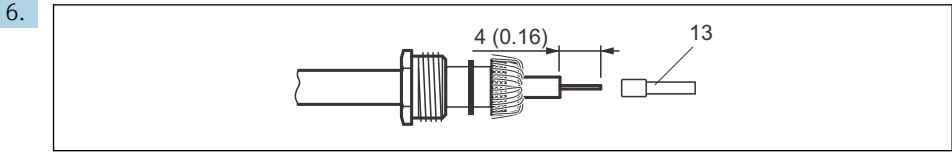

A0005746

9  Terminating the pH connecting cable for mounting the BNC elbow plug. Dimensions in mm (inch)

Remove the inner insulation (4 mm (0.16")), fit the end ferrule 13 on the stripped inner conductor and secure the end ferrule with a crimping pliers.

7. Slide the BNC connector housing 9 over the cable. The inner conductor must be located on the clamping surface 10 of the connector.

8. Tighten the cable gland 5.

9. Insert the clamping piece 11 and screw in the connector cover 12. This creates a reliable connection between the inner conductor and the connector pin.

Sensor	Maximum cable length
Chlorine/chlorine dioxide sensors CCS140/141/240/ 241	Max. 30 m (98.4 ft) with cable CMK
Total chlorine sensor CCS120	Max. 15 m (49.2 ft) with cable CYK71
pH/ORP measurement	Max. 50 m (164 ft) with cable CYK71

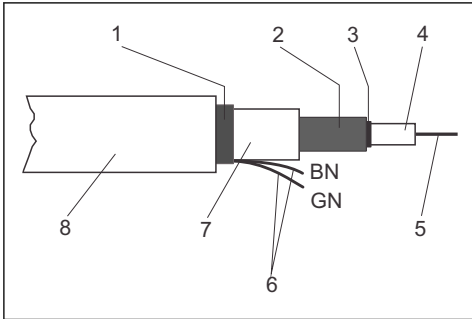

A0002331

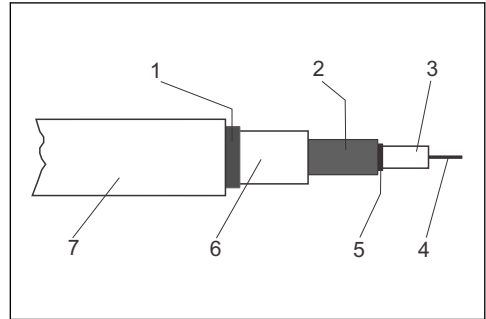

A0002332

10 Structure of cable CMK

- 1 Outer shield
- 2 Inner shield, anode
- 3 Semiconductor layer
- 4 Inner insulation
- 5 Inner conductor, measuring signal
- 6 Temperature sensor connection
- 7 2nd insulation
- 8 Outer insulation

11 Structure of cable CYK71

- 1 Outer shield
- 2 Inner shield, reference signal
- 3 Inner insulation
- 4 Inner conductor, measuring signal
- 5 Semiconductor layer
- 6 2nd insulation
- 7 Outer insulation

NOTICE

Incorrect measurement due to short-circuit

- ▶ Make sure to remove the black semiconductor layer as far as the inner shield when connecting cable CMK and CYK71.

5.6 Alarm contact

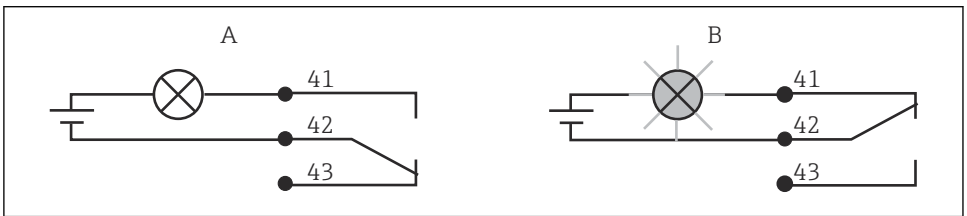

A0052966

12 Recommended fail-safe switching for the alarm contact

- A Normal operating status
 B Alarm condition

Normal operating status

Device in operation and no error message present (alarm LED off):

- Relay energized
- Contact 42/43 closed

Alarm condition

Error message present (alarm LED red) or device defective or de-energized (alarm LED off):

- Relay de-energized
- Contact 41/42 closed

5.7 Post-connection check

Once the electrical connection is set up, carry out the following checks:

Device condition and specifications	Notes
Are the devices and cables free from damage on the outside?	Visual inspection

Electrical connection	Notes
Are the mounted cables strain relieved?	
Are the connected cables provided with strain relief?	
Is the cable run correct, without loops and cross-overs?	
Are the power cable and signal cables connected correctly and in accordance with the wiring diagram?	
Are all the screw terminals tightened?	
Are all the cable entries fitted, tightened and leak-proof?	

6 Operation options

6.1 Overview of operation options

Options for controlling the transmitter:

- On site via the key field
- Via the HART interface (optional, with corresponding order version) with:
 - HART handheld terminal
 - PC with HART modem and the Fieldcare software package
- Via PROFIBUS PA/DP (optional, with corresponding order version) by PC with a corresponding interface and the Fieldcare software package or via a programmable logic controller (PLC).



For operation via HART or PROFIBUS PA/DP, observe the relevant sections in the additional Operating Instructions:







- PROFIBUS PA/DP, field communication for Liquisys M CXM223/253, BA00209C/07/DE
- HART, field communication for Liquisys M CXM223/253, BA00208C/07/DE

The following section only explains operation via the keys.

6.2 Display and operating elements

6.2.1 Structure and function of the operating menu

LED indicators

  <small>A0027220</small>	Indicates the current operating mode, "Auto" (green LED) or "Manual" (yellow LED)
  <small>A0027222</small>	Indicates the activated relay in the "Manual" mode (red LED) The status of relays 3 and 4 is indicated on the LC display.
  <small>A0027221</small>	Indicates the working status of relay 1 and 2 LED green: measured value within the permitted limit, relay inactive LED red: measured value outside the permitted limit, relay active
 <small>A0027218</small>	Alarm display, e.g. in event of continuous limit value overshoot, temperature sensor failure or system error (see error list)

LC display

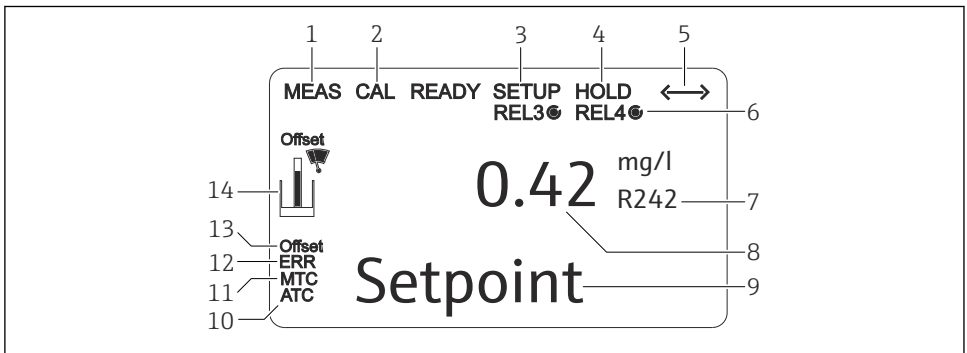

A0060187

13 Transmitter LC display

- 1 Indicator for measuring mode (normal operation)
- 2 Indicator for calibration mode
- 3 Indicator for setup mode (configuration)
- 4 Indicator for "Hold" mode (current outputs remain at last current state)
- 5 Indicator for receipt of a message on devices with communication
- 6 Indicator of working status of relays 3/4: ○ inactive, ● active
- 7 Indicator for function code

- 8 *In measuring mode: measured variable - in setup mode: configured variable*
- 9 *In measuring mode: secondary measured value - in setup/calibr. mode: e.g. Setting value*
- 10 *Indicator for autom. Temperature compensation*
- 11 *Indicator for man. Temperature compensation*
- 12 *"Error": error display*
- 13 *Temperature offset*
- 14 *Sensor symbol (see the "Calibration" section)*

Operating elements

The display shows the current measured value and the temperature simultaneously. This provides you with the most important process data at a glance. Help text in the configuration menu helps users configure the device parameters.

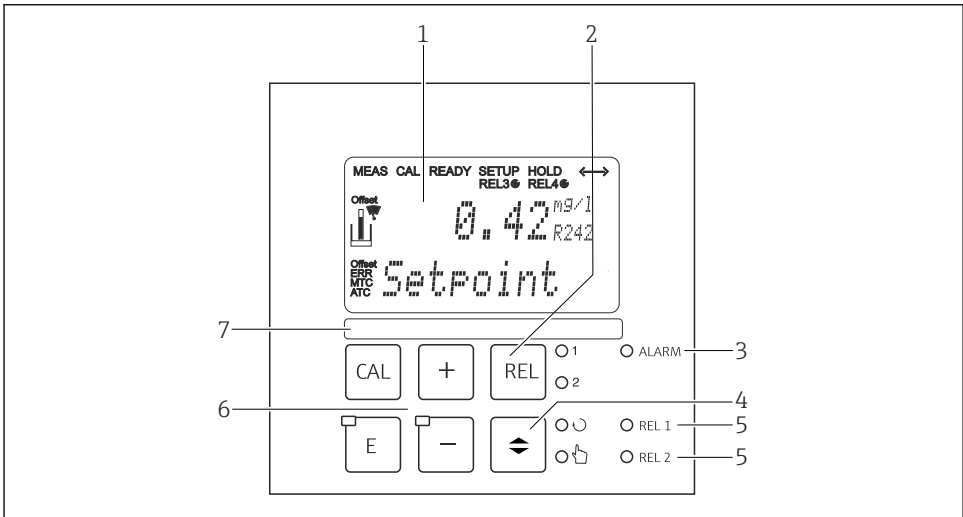





A0060193

14 Operating elements

- 1 *LC display for displaying the measured values and configuration data*
- 2 *Key to switch relays in manual mode and to display the active contact*
- 3 *LED for alarm function*
- 4 *Changeover switch for automatic/manual mode*
- 5 *LEDs for limit contactor relay (switch status)*
- 6 *Main operating keys for calibration and device configuration*
- 7 *Field for user-defined information*

Functions of keys

 <p style="text-align: right; font-size: small;">A0027235</p>	<p>CAL key</p> <p>When you press the CAL key, the device first prompts you for the calibration access code:</p> <ul style="list-style-type: none"> ■ Code 22 for calibration ■ Code 0 or any other code for reading the last calibration data <p>Use the CAL key to accept the calibration data or to switch from field to field within the calibration menu.</p>
 <p style="text-align: right; font-size: small;">A0027236</p>	<p>ENTER key</p> <p>When you press the ENTER key, the device first prompts you for the setup mode access code:</p> <ul style="list-style-type: none"> ■ Code 22 for setup and configuration ■ Code 0 or any other code for reading all the configuration data. <p>The ENTER key has several functions:</p> <ul style="list-style-type: none"> ■ Calls up the Setup menu from the measuring mode ■ Saves (confirms) data entered in the setup mode ■ Moves on within function groups
 <p style="text-align: right; font-size: small;">A0027241</p>	<p>REL key</p> <p>In the manual mode, you can use the REL key to switch between the relay and the manual start of cleaning.</p> <p>In the automatic mode, use the REL key to read out the switch-on points (for limit contactor) or set points (for PID controller) assigned to the relay in question.</p> <p>Press the PLUS key to jump to the settings of the next relay.</p> <p>Use the REL key to get back to the display mode (automatic return after 30 s).</p>
 <p style="text-align: right; font-size: small;">A0027234</p>	<p>AUTO key</p> <p>Use the AUTO key to switch between automatic mode and manual mode.</p>

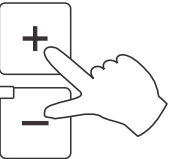
 <p>A0027240</p>	<p>PLUS key and MINUS key</p> <p>In the Setup mode, the PLUS and MINUS keys have the following functions:</p> <ul style="list-style-type: none"> ■ Selection of function groups. Press the MINUS key to select the function groups in the order given in the "System configuration" section. ■ Configuration of parameters and numerical values ■ Operation of the relays in manual mode <p>In the measuring mode, the device displays the following functions in sequence by repeatedly pressing the PLUS button:</p> <ul style="list-style-type: none"> ■ Temperature displayed in °F ■ Temperature is hidden ■ pH measured value or ORP (only for EP version) ■ pH sensor signal in mV (only for EP version) ■ Sensor current of chlorine/chlorine dioxide sensor in nA ■ Zero current of sensor CCS120 ■ Current input signal in % ■ Current input signal in mA ■ Return to basic settings <p>In the measuring mode, the device displays the following sequence of information by repeatedly pressing the MINUS key:</p> <ul style="list-style-type: none"> ■ The current faults are displayed consecutively (max. 10). ■ Once all the faults have been displayed, the standard measurement display appears. In the function group F, an alarm can be defined separately for each error code.
 <p>A0027237</p>	<p>Escape function</p> <p>If you press the PLUS and MINUS key simultaneously, you return to the main menu, or are taken to the end of calibration if calibrating. If you press the PLUS and MINUS key again, you return to the measuring mode.</p>

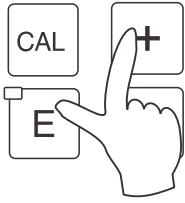
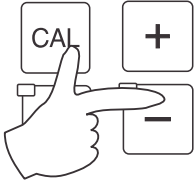
 <p style="text-align: right; font-size: small;">A0027238</p>	<p>Locking the keyboard</p> <p>Press the PLUS and ENTER key simultaneously for at least 3 s to lock the keyboard against any unauthorized data entry. All the settings can continue to be read.</p> <p>The code prompt displays the code 9999.</p>
 <p style="text-align: right; font-size: small;">A0027239</p>	<p>Unlocking the keyboard</p> <p>Press the CAL and MINUS key simultaneously for at least 3 s to unlock the keyboard.</p> <p>The code prompt displays the code 0.</p>

6.3 Access to operating menu via onsite display

6.3.1 Automatic/manual mode

The transmitter normally operates in automatic mode. Here, the relays are triggered by the transmitter. In the manual mode, you can trigger the relays manually using the REL key or start the cleaning function.

Switching operating modes:

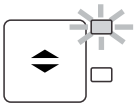
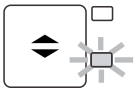
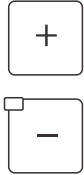
 <p style="text-align: right; font-size: small;">A0027242</p>	<p>1. The transmitter is in automatic mode. The top LED (green) next to the AUTO key is lit.</p>
 <p style="text-align: right; font-size: small;">A0027243</p>	<p>2. Press the AUTOMATIC key.</p>
 <p style="text-align: right; font-size: small;">A0027240</p>	<p>3. To enable the manual mode, enter code 22 via the PLUS and MINUS keys and press ENTER to confirm.</p> <p>The lower LED (manual mode) is lit.</p>

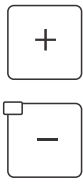
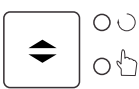
 <p>A0027241</p>	<p>4.</p>	<p>Select relay or function. Use the REL key to switch between the relays. The relay selected and the switch status (ON/OFF) is displayed on the second line of the display. In the manual mode, the measured value is displayed continuously (e.g. for measured value monitoring for dosing functions).</p>
 <p>A0027240</p>	<p>5.</p>	<p>Switch relays. The relay is switched on with PLUS and switched off with MINUS. The relay remains in this switched state until it is switched again.</p>
 <p>A0027234</p>	<p>6.</p>	<p>Press the AUTOMATIC key to return to the measuring mode, i.e. to the automatic mode. All the relays are triggered again by the transmitter.</p>

-  The operating mode remains in effect even after a power failure. The relays assume the quiescent state, however.
- The manual mode has priority over all other automatic functions.
- Hardware locking is not possible in the manual mode.
- The manual settings are kept until they are actively reset.
- Error code E102 is signaled during manual operation.

6.3.2 Operation concept

Operating modes

Calibration mode

1. Press the **CAL** key.
2. Enter the code 22 with the +/- keys.
3. Press the **CAL** key again.

Setup mode

1. Press the **E** key.
2. Enter the code 22 with the +/- keys.
3. Press **E** again.

-  If no key is pressed in the setup mode for approx. 15 min, the device automatically returns to the measuring mode. Any active hold (hold during setup) is canceled.

Access codes

All device access codes are fixed and cannot be altered. When the device requests the access code, it distinguishes between different codes.

- **CAL key + code 22**: access to Calibration and Offset menu
- **ENTER key + code 22**: access to the menus for the parameters which make configuration and user-specific settings possible
- **PLUS + ENTER keys** simultaneously (min. 3 s): lock the keyboard
- **CAL + MINUS keys** simultaneously (min. 3 s): unlock the keyboard
- **CAL or ENTER key + any code**: access to read mode, i.e. all the settings can be read but not modified.

The device continues measuring in the read mode. It does not shift to the "Hold" status. The current output and the controllers remain active.

Menu structure

The configuration and calibration functions are arranged in function groups.

- In the setup mode, select a function group with the PLUS and MINUS keys.
- In the function group itself, switch from function to function with the ENTER key.
- Within the function, select the desired option once again with the PLUS and MINUS keys or edit the settings with these keys. Then confirm with the ENTER key and continue.
- Press the PLUS and MINUS keys simultaneously (Escape function) to exit programming (return to the main menu).
- Press the PLUS and MINUS keys simultaneously again to switch to the measuring mode.



If a modified setting is not confirmed by pressing ENTER, the old setting is retained.

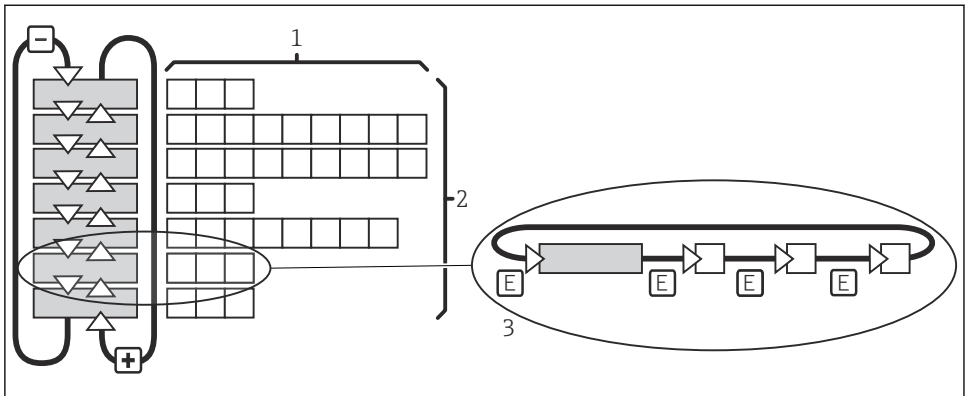

A0059578

15 Menu structure

- 1 Functions (selection of parameters, entry of numbers)
- 2 Function groups, scroll backwards and forwards with the PLUS and MINUS keys
- 3 Switch from function to function with the ENTER key

7 Commissioning

7.1 Function check

Incorrect connection, incorrect supply voltage

Safety risks for staff and device malfunctions!

- ▶ Check that all connections have been established correctly in accordance with the wiring diagram.
- ▶ Ensure that the supply voltage matches the voltage indicated on the nameplate.

7.2 Switching on the device

Familiarize yourself with the operation of the transmitter before switching it on for the first time. In particular, please read the "Basic safety instructions" and "Operation options" sections. After power-up, the device performs a self-test and then switches to the measuring mode.

Now calibrate the sensor in accordance with the instructions in the "Calibration" section.

 During initial commissioning, the sensor must be calibrated so that the measuring system can return precise measurement data.

Then perform the first configuration in accordance with the instructions in the "Quick setup" section. The values set by the user are kept even in the event of a power failure.

The following function groups are available in the transmitter (the groups that are only available in the Plus Package are marked accordingly in the functional description):

Setup mode

- SETUP 1 (A)
- SETUP 2 (B)
- CURRENT INPUT (Z)
- CURRENT OUTPUT (O)
- ALARM (F)
- CHECK (P)
- RELAY (R)
- SERVICE (S)
- E+H SERVICE (E)
- INTERFACE (I)

Calibration and offset mode

CALIBRATION (C)

 For a detailed explanation of the function groups available in the transmitter, see the "Device configuration" section.

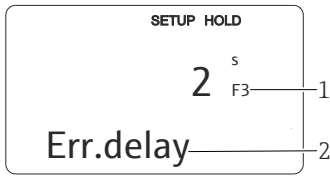

A0060196

16 Information for the user on the display

- 1 Function indicator: The code shown indicates the function position in the function group.
- 2 Additional information

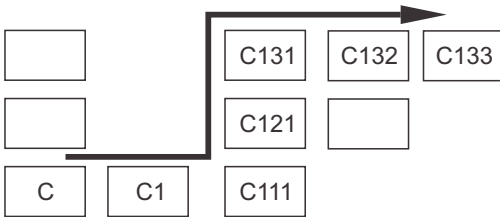

A0027502

17 Function code

To make it easier to select and find function groups and functions, a code for the corresponding field is displayed for each function. The structure of this code is shown in → 17. The function groups are indicated as letters in the first column (see the names of the function groups). The functions of the individual groups are displayed incrementally by row and by column.

7.3 Quick start guide

After power-up, some settings are necessary to configure the most important functions of the transmitter which are required for correct measurement. The following section gives an example of this.

User input		Range of adjustment (factory settings in bold)
1.	Press the ENTER key.	
2.	Enter the code 22 to open access to the menus. Press the ENTER key.	
3.	Press the MINUS key until the "Service" function group is displayed.	
4.	Press the ENTER key to make the required settings.	
5.	S1 In S1, select the language, e.g. "ENG" for English. Confirm the entry by pressing the ENTER key.	ENG = English GER = German FRA = French ITA = Italian NEL = Dutch ESP = Spanish
6.	Press the PLUS and MINUS keys simultaneously to exit the "Service" function group.	
7.	Press the MINUS key until the "Setup 1" function group is displayed.	
8.	Press the ENTER key to configure the settings for "Setup 1".	

User input		Range of adjustment (factory settings in bold)
9.	A1 Select the desired sensor type in A1. Confirm the entry by pressing the ENTER key.	120 = CCS120 140 = CCS140 141 = CCS141 240 = CCS240 241 = CCS241
10.	A2 Select the desired unit in A2. Confirm the entry by pressing the ENTER key.	mg/l ppm ppb
11.	A3 If the proximity switch INS is connected, flow monitoring of the sample flow can be switched on in A3 via assembly CCA250. Confirm the entry by pressing the ENTER key.	Off INS
12.	A4 If flow briefly falls below the threshold value, you can suppress controller switch-off by entering a delay time in A4. Confirm the entry by pressing the ENTER key.	0 s 0 to 2000 s
13.	A5 In A5, enter the delay time for controller switch-on. In the case of chlorine/chlorine dioxide control, a delay until the reception of a representative measured value is recommended after a long period without flow. Confirm the entry by pressing the ENTER key.	0 s 0 to 2000 s
14.	A6 Select the binary input in A6. Confirm the entry by pressing the ENTER key.	Hold = external hold Clean = cleaning trigger
15.	A7 Enter the measured value damping in A7. Measured value damping causes the measured value to be averaged over the specified number of individual measured values (if A7 = 1, no damping takes place). Confirm the entry by pressing the ENTER key. The display returns to the initial display of the "Setup 1" function group.	1 1 to 60
16.	Press PLUS and MINUS simultaneously to switch to the measuring mode.	



71722934

www.addresses.endress.com
