

# Special Documentation

## Source Container FQG60, FQG61/62, FQG63, FQG66, FQG74

Supplementary safety instructions for radiation sources  
and source containers approved for use in Canada

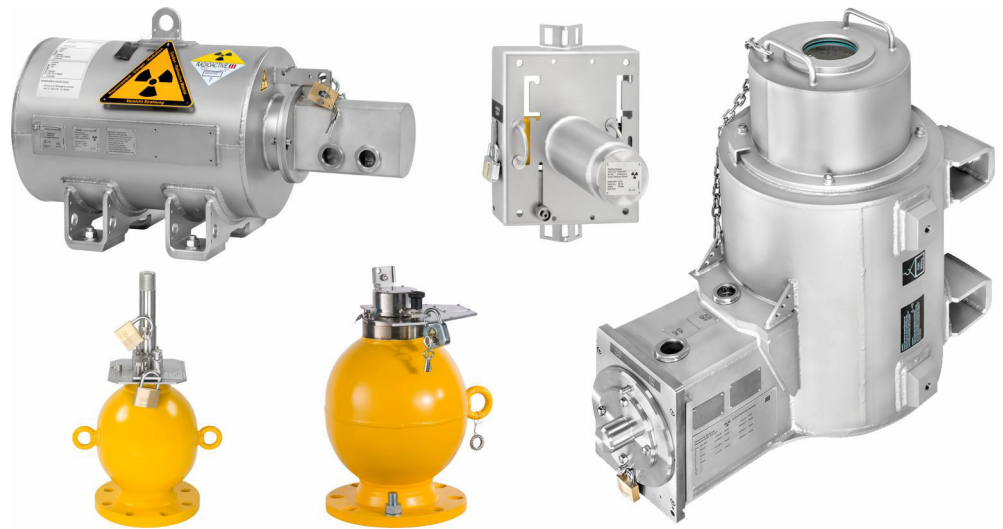



## Table of contents

<b>1</b>	<b>About this document</b> .....	<b>4</b>
1.1	Symbols used .....	4
<b>2</b>	<b>Basic safety instructions</b> .....	<b>6</b>
2.1	Requirements for the personnel .....	6
<b>3</b>	<b>Supplementary documentation</b> .....	<b>7</b>
<b>4</b>	<b>Scope of application</b> .....	<b>8</b>
<b>5</b>	<b>Leak test</b> .....	<b>9</b>
5.1	Equipment to be tested .....	9
5.2	Frequency of leak testing .....	9
5.3	Leak test procedure .....	9
5.4	Source container FQG60 .....	10
5.5	Source Container FQG61/62 .....	11
5.6	Source Container FQG63 .....	12
5.7	Source Container FQG66, manual version (Order code 020, option A) .....	13
5.8	Source Container FQG66, pneumatic version (Order code 020, option L) .....	14
5.9	Source Container FQG74, lowerable source magazine .....	15
5.10	Source Container FQG74, rigid source magazine .....	17
5.11	Visual inspection .....	20
<b>6</b>	<b>Emergency procedure</b> .....	<b>20</b>
6.1	Purpose and overview .....	20
6.2	Procedure for Source Container FQG60 .....	20
6.3	Procedure for Source Container FQG61/ FQG62 .....	21
6.4	Procedure for Source Container FQG63/ FQG74 .....	22
6.5	Procedure for Source Container FQG66 .....	23

# 1 About this document

## 1.1 Symbols used

### 1.1.1 Safety symbols

#### DANGER

This symbol alerts you to a dangerous situation. Failure to avoid this situation will result in serious or fatal injury.

#### WARNING

This symbol alerts you to a potentially dangerous situation. Failure to avoid this situation can result in serious or fatal injury.

#### CAUTION

This symbol alerts you to a potentially dangerous situation. Failure to avoid this situation can result in minor or medium injury.

#### NOTICE

This symbol alerts you to a potentially harmful situation. Failure to avoid this situation can result in damage to the product or something in its vicinity.

### 1.1.2 Radiation warning sign



Warning symbol for radioactive source according to ISO 7010

#### Warning sign for ionizing radiation

Identification of places and objects in and around which the presence of ionizing radiation is to be expected.



Warning symbol for highly radioactive source according to ISO 21482

#### High radiation warning sign

- Warns of highly radioactive substances or ionizing radiation.
- Highly radioactive sources are marked separately on the source containers with the wording "highly radioactive source" and the supplemental warning symbol according to ISO 21482.

### 1.1.3 Symbols for certain types of information and graphics

#### Permitted

Procedures, processes or actions that are permitted

#### Forbidden

Procedures, processes or actions that are forbidden

#### Tip

Indicates additional information



Reference to documentation



Reference to graphic



Notice or individual step to be observed

1., 2., 3.

Series of steps



Result of a step

1, 2, 3, ...

Item numbers

A, B, C, ...

Views



→  **Safety instructions**

Observe the safety instructions contained in the associated Operating Instructions

## 2 Basic safety instructions

### DANGER

#### **Danger from ionizing radiation in case of incorrect handling or a defective source container**

Hazard for persons and the environment posed by ionizing radiation and contamination. Ionizing radiation and contamination could increase the risk of cancer and the risk of genetic birth defects. Depending on the dose received, ionizing radiation could lead to immediate physical harm, such as nausea, vomiting, hair loss, changes to blood count, serious tissue damage and even death.

- ▶ **The instructions and warning notes in this manual relating to dangers to health posed by ionizing radiation and contamination must be strictly observed. Disregard for these instructions and warning notes could lead to serious injuries or death and hazards for the environment.**
- ▶ Observe applicable national requirements for radioactive radiation sources. Observe requirements for fire protection measures in particular.
- ▶ Observe the conditions of use of radiation sources with respect to environmental conditions (e.g. vibration or operating temperature).
- ▶ In cases of doubt, contact the responsible radiation safety officer, the responsible national inspectorate or the manufacturer.

### DANGER

#### **Danger from ionizing radiation if radiation sources lost**

If radiation sources are lost, there is a danger to the general public and the environment

- ▶ **The instructions and warning notes in this manual relating to dangers to health posed by ionizing radiation and contamination must be strictly observed. Disregard for these instructions and warning notes could lead to serious hazards for the environment and public safety.**
- ▶ Observe applicable national requirements for anti-theft measures for radioactive radiation sources throughout the entire life cycle (from delivery to disposal).
- ▶ There is a risk of radioactive material being used for criminal or premeditated unauthorized acts, which poses a threat to public safety.

### 2.1 Requirements for the personnel

#### WARNING

#### **Danger from inadequately qualified personnel.**

Physical damage and personal injury. Particularly as a consequence of incorrect handling.

- ▶ The requirements for personnel described below are mandatory for the plant operator.

#### **Maintenance personnel - Radiation**

Maintenance personnel (radiation) carry out any maintenance work affecting the radiation source, including disassembly and replacement.

Maintenance personnel (radiation) must comply with the following requirements:

- They must be authorized and monitored in relation to radiation exposure
- They must be trained specialists in radiation protection
- They must be authorized by the plant owner/operator.

#### **Transport personnel**

Transport personnel transport the product or parts thereof from the manufacturer or warehouse to the place of installation, for example. Transport personnel must comply with the following requirements:

They must be qualified to transport "Class 7 hazardous goods".

**Disposal personnel**

Disposal personnel dispose of the product or parts thereof. Disposal personnel must comply with the following requirements:

- They must be authorized and monitored in relation to radiation exposure
- They must be trained specialists in radiation protection
- They must be authorized by the disposal company.

**Radiation safety officer**

The radiation safety officer is responsible for ensuring compliance with all applicable legal regulations. The company/operator must appoint a radiation safety officer in accordance with the relevant national law(s). The radiation safety officer is responsible for the following, among other tasks:

- Monitoring the source container at the place of installation
- Training of staff in radiation protection
- Developing and implementing measures in an emergency

. The radiation safety officer can therefore be reached at all times.

The radiation safety officer is:

- Trained for the role
- Someone who is recognized nationally for this role
- A specialist who is authorized by the plant operator.

### 3 Supplementary documentation

 For an overview of the scope of the associated Technical Documentation, refer to the following:

- *Device Viewer* ([www.endress.com/deviceviewer](http://www.endress.com/deviceviewer)): Enter the serial number from the nameplate
- *Endress+Hauser Operations app*: Enter serial number from nameplate or scan matrix code on nameplate.

## **4 Scope of application**

The safety instructions provided in this document apply to radiation sources and source containers which have been approved by the CNSC for use in Canada.

This document does not substitute the Operating Instructions BA02521F (FQG60), BA02577F (FQG61/62), BA02594F (FQG63), BA01327F (FQG66), BA02365F, BA02361F (FQG74) and Technical Information TI00445F (FQG60), TI00435F (FQG61/62), TI00446F (FQG63), TI01171F (FQG66), TI01798F (FQG74). When operating a source container within Canada, the respective Operating Instructions and procedures described in this document must be strictly observed.

## 5 Leak test

### WARNING

**Be aware of the risk of possible contamination.**

- ▶ Use appropriate personal protective equipment.

### WARNING

**Risk of serious bodily harm if leak test not carried out.**

A leak test is not only required as part of routine checks but must also be performed whenever an incident occurs that may impair the casing around the radiation source. In such cases, the leak test must be arranged by the responsible radiation safety officer, with due consideration to the applicable regulations. The leak test must comprise both the source container and all other affected parts of the process vessel and must be performed as soon as possible after the incident. The leak test procedure described below is intended for the following situations:

- ▶ For routine tests during continuous operation
- ▶ When the source container has been in storage for an extended period
- ▶ When the source container is to be put back into operation after storage
- ▶ If the source container is to be used as a Type A package

 The leak test requires instructed personnel. The radiation safety officer is responsible for compliance with all regulations and for how it is carried out.

See the "Requirements for personnel" section.

Check the leak-tightness of the source capsules at regular intervals. The frequency of the leak tests must correspond to the intervals specified by the authorities or handling permit.

### 5.1 Equipment to be tested

A leak test is required if the source activity is greater than 50 Mbq.

### 5.2 Frequency of leak testing

Subject to other regulations by the CNSC, the device has to be tested at the following intervals:

- Once every 12 months for radiation sources in continuous operation
- Once every 24 months if the radiation source is in permanent storage
- Immediately after the radiation source is put back into operation after being in storage for 12 or more consecutive months (this replaces all other tests that were performed during the previous 12 months while the radiation source was in storage)

 Leak tests are required whenever an incident occurs that could damage the sealed radiation source or the shielding. The leak test must be performed as soon as possible after the incident.

### 5.3 Leak test procedure

-  Ensure that the person collecting the leak test samples has:
- access to and follows approved leak test procedures
  - received radiation safety training to control any associated radiation hazard
  - sufficient sampling materials and leak test sampling certificates.

## 5.4 Source container FQG60

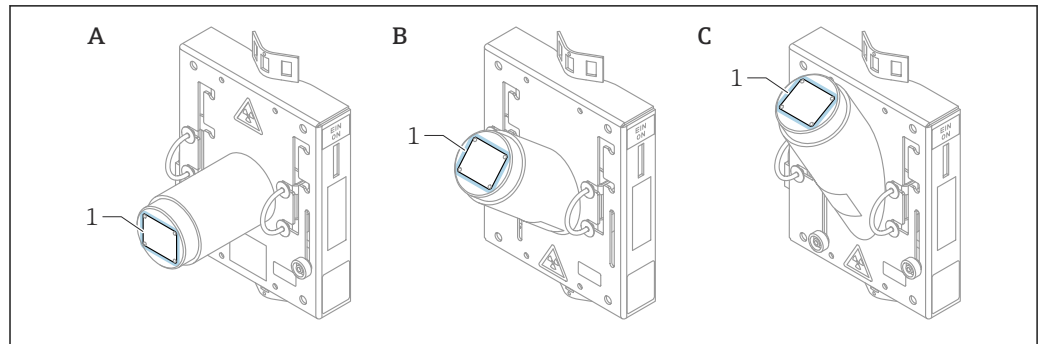

- A Point level and density measurement (Ordering feature: Emission angle; application; option: 3)  
 B Level measurement (Ordering feature: Emission angle; application; option: 4)  
 C Density measurement (Ordering feature: Emission angle; application; option: 5)  
 1 Wipe surface for leak test along the edge of the nameplate

1. Take a wipe sample from the wipe surface specified above.
  - ↳ **The wipe sample can be taken when the shutter is in the "ON" or "OFF" position.**
2. Have the samples analyzed in a laboratory approved by the CNSC. A radiation source is considered to be leaking if more than 200 Bq (5.4 nCi) are detected in the leak test sample.

### **⚠ WARNING**

#### **Risk of possible contamination**

The source capsule is potentially leaking. Contact with non-encapsulated, radioactive material can cause internal or external contamination, resulting in serious health risks and contamination of equipment, work areas or personnel.

- ▶ Stop using the device immediately.
- ▶ Contact the responsible radiation safety officer immediately for further instruction.
- ▶ Take appropriate measures to prevent a potential spread of radioactive contamination from the radiation source.
- ▶ Secure the radiation source.
- ▶ Notify the CNSC immediately that a leaking radiation source has been detected.

## 5.5 Source Container FQG61/62

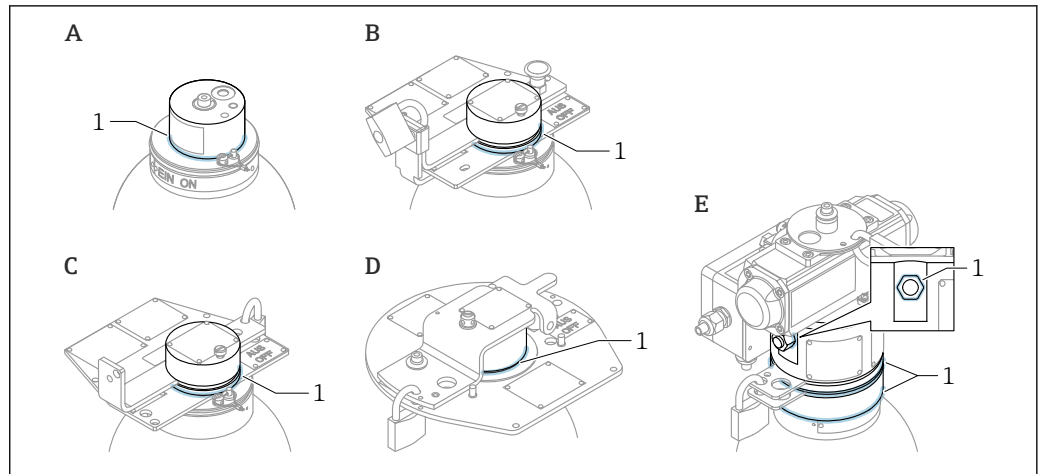

A0018425

- A FQG61/FQG62; order code 020, option A  
 B FQG61/FQG62; order code 020, option B  
 C FQG61/FQG62; order code 020, option C  
 D FQG61/FQG62; order code 020, option D  
 E FQG61/FQG62; order code 020, option K, L, M or N

### **⚠ WARNING**

**Risk of injury from ionizing radiation if the radiation source is inadvertently switched on with the remote control!**

- ▶ In the case of source containers with a pneumatic actuator, the source container must be secured and locked in the 'off' position with a padlock before the wipe test. In the case of manually operated source containers, the wipe test can be performed irrespective of the switch position.

1. Take a wipe sample at the following points at least:
  - ↳ FQG61/FQG62; order code 020, option A, B, C, D: along the groove between the source insert and the housing
  - FQG61/FQG62; order code 020, option K, L, M, N: along the thread of the proximity switches and the three annular grooves on the cylinder housing
2. Have the samples analyzed in a laboratory approved by the CNSC. A radiation source is considered to be leaking if more than 200 Bq (5.4 nCi) are detected in the leak test sample.

### **⚠ WARNING**

**Risk of possible contamination**

The source capsule is potentially leaking. Contact with non-encapsulated, radioactive material can cause internal or external contamination, resulting in serious health risks and contamination of equipment, work areas or personnel.

- ▶ Stop using the device immediately.
- ▶ Contact the responsible radiation safety officer immediately for further instruction.
- ▶ Take appropriate measures to prevent a potential spread of radioactive contamination from the radiation source.
- ▶ Secure the radiation source.
- ▶ Notify the CNSC immediately that a leaking radiation source has been detected.

## 5.6 Source Container FQG63

### **⚠ WARNING**

#### **Hot source magazine and hot rope extensions due to process heat transfer.**

This could result in burns to hands.

- ▶ Wear protective equipment.
- ▶ Define organizational measures for protection from hot parts. Warn equipment operators of the danger posed by hot parts on the source container, e.g. in the form of notices and training.
- ▶ The plant operator must ensure that the radiation sources can be safely set to the OFF position in an emergency. A risk of injury from hot parts on the source container must be taken into consideration.
- ▶ If possible, allow the process to cool down before the ropes are retracted.

### **⚠ WARNING**

#### **Be aware of the risk of possible contamination.**

- ▶ Use appropriate personal protective equipment.
- ▶ Follow safety measures when putting away the rope extensions.

### **⚠ CAUTION**

#### **When the radiation sources are being raised, there is a risk of injury from rope defects on the rope extensions (e.g. due to frayed wire).**

This could result in personal injury in the form of cuts and abrasions.

- ▶ Wear protective equipment.

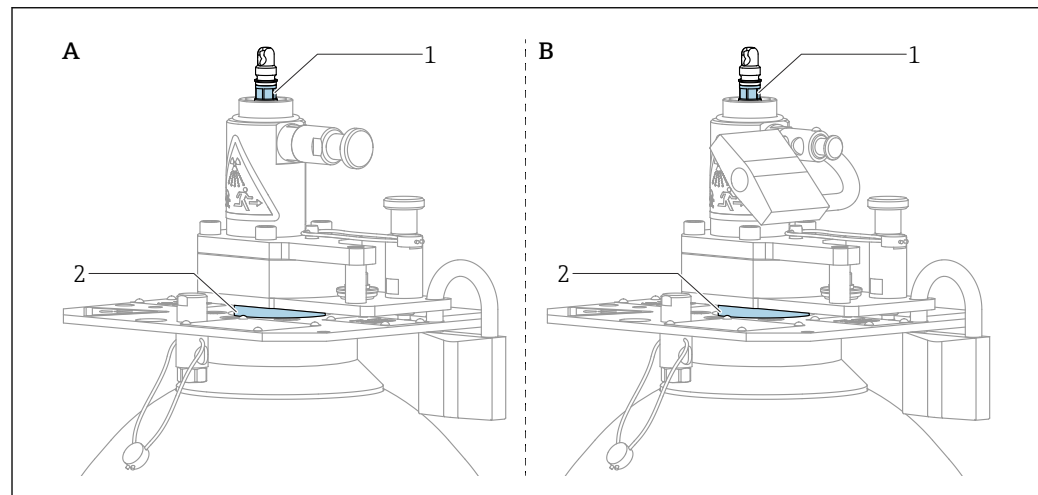

A0019423

#### **1** Alternative test areas for leak test

A Order code 020, option B

B Order code 020, option C

1. The source container must be in the "AUS/OFF" position.  
Wipe along the annular gap junction (1)/(2) in accordance with the diagram.
2. Have the samples analyzed in a laboratory approved by the CNSC. A radiation source is considered to be leaking if more than 200 Bq (5.4 nCi) are detected on a leak test sample.

**⚠ WARNING****Risk of possible contamination**

The source capsule is potentially leaking. Contact with non-encapsulated, radioactive material can cause internal or external contamination, resulting in serious health risks and contamination of equipment, work areas or personnel.

- ▶ Stop using the device immediately.
- ▶ Contact the responsible radiation safety officer immediately for further instruction.
- ▶ Take appropriate measures to prevent a potential spread of radioactive contamination from the radiation source.
- ▶ Secure the radiation source.
- ▶ Notify the CNSC immediately that a leaking radiation source has been detected.

## 5.7 Source Container FQG66, manual version (Order code 020, option A)

**i** The wipe test can be performed when the source holder is in either the "EIN/ON" or "AUS/OFF" position.

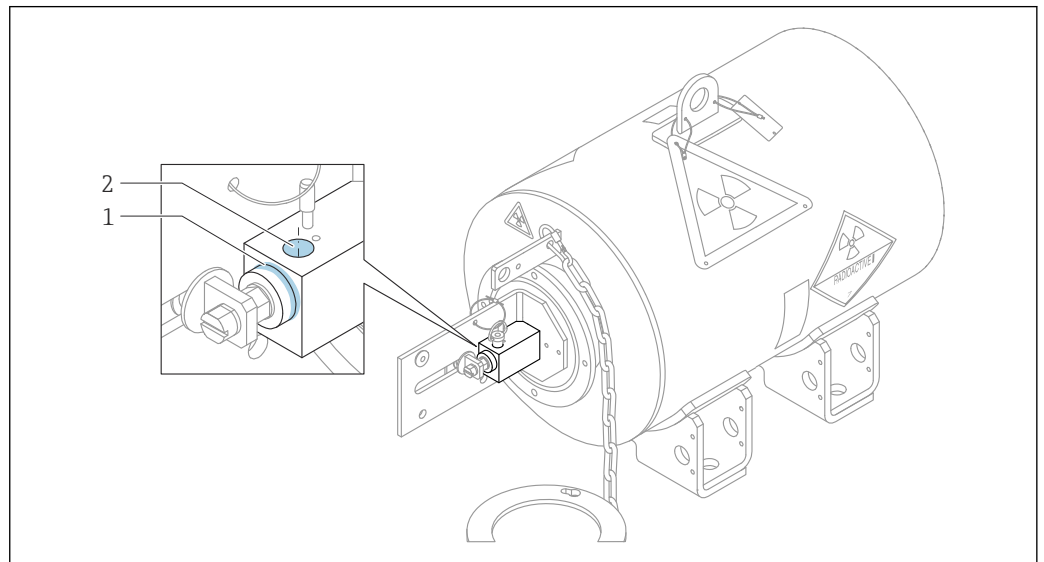

A0027388

- 1 Wipe surface at border between source holder and housing block
- 2 Wipe surface in the bore hole of the lock pin

1. The wipe sample must at least be taken at the border between the source holder and the housing block or, if necessary, in the bore hole of the lock pin.
2. Have the samples analyzed in a laboratory approved by the CNSC. A radiation source is considered to be leaking if more than 200 Bq (5.4 nCi) are detected on a leak test sample.

**⚠ WARNING****Risk of possible contamination**

The source capsule is potentially leaking. Contact with non-encapsulated, radioactive material can cause internal or external contamination, resulting in serious health risks and contamination of equipment, work areas or personnel.

- ▶ Stop using the device immediately.
- ▶ Contact the responsible radiation safety officer immediately for further instruction.
- ▶ Take appropriate measures to prevent a potential spread of radioactive contamination from the radiation source.
- ▶ Secure the radiation source.
- ▶ Notify the CNSC immediately that a leaking radiation source has been detected.

## 5.8 Source Container FQG66, pneumatic version (Order code 020, option L)

### **CAUTION**

#### **Risk of being crushed by moving parts!**

The actuator contains moving parts that can cause crushing injuries if anyone reaches into it.

- ▶ Do not remove the cover while the pneumatic auxiliary power supply for the drive is effectively connected.
- ▶ When working on the source container, deactivate and lock the pneumatic auxiliary power supply.
- ▶ Do not wedge in objects to stop the drive moving.

**i** Before performing the wipe test, disconnect the pneumatic drive from the compressed air supply and secure it in the "AUS/OFF" position with the locking bolt.

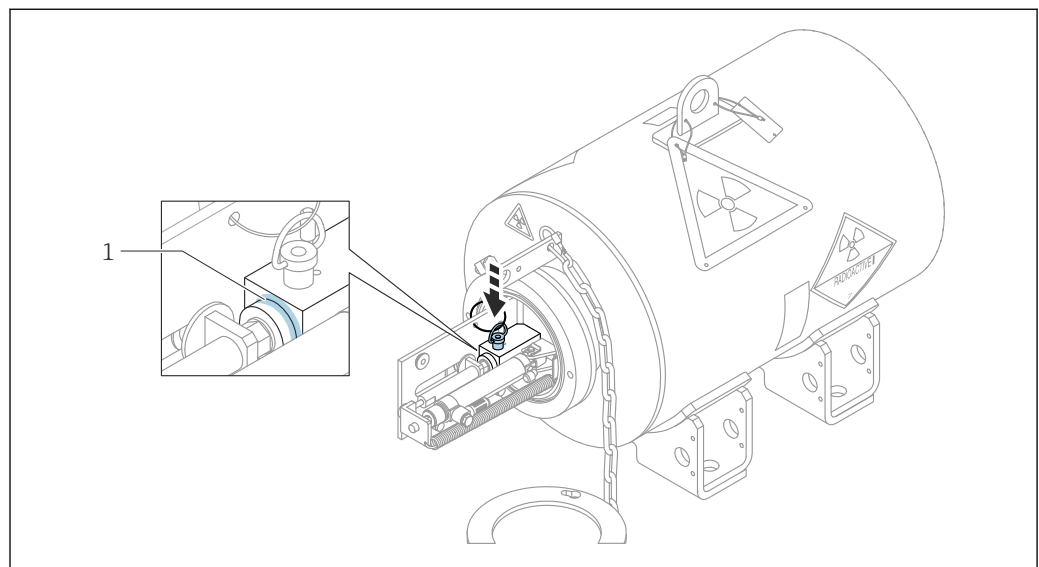

A0026816

1 Wipe surface

1. The wipe sample must be taken at least at the border between the source holder and the housing block.
2. Have the samples analyzed in a laboratory approved by the CNSC. A radiation source is considered to be leaking if more than 200 Bq (5.4 nCi) are detected on a leak test sample.

### **WARNING**

#### **Risk of possible contamination**

The source capsule is potentially leaking. Contact with non-encapsulated, radioactive material can cause internal or external contamination, resulting in serious health risks and contamination of equipment, work areas or personnel.

- ▶ Stop using the device immediately.
- ▶ Contact the responsible radiation safety officer immediately for further instruction.
- ▶ Take appropriate measures to prevent a potential spread of radioactive contamination from the radiation source.
- ▶ Secure the radiation source.
- ▶ Notify the CNSC immediately that a leaking radiation source has been detected.

## 5.9 Source Container FQG74, lowerable source magazine

### **⚠ WARNING**

#### **Hot source magazine and hot rope extensions due to process heat transfer.**

This could result in burns to hands.

- ▶ Wear protective equipment.
- ▶ Define organizational measures for protection from hot parts. Warn equipment operators of the danger posed by hot parts on the source container, e.g. in the form of notices and training.
- ▶ The plant operator must ensure that the radiation sources can be safely set to the OFF position in an emergency. A risk of injury from hot parts on the source container must be taken into consideration.
- ▶ If possible, allow the process to cool down before the ropes are retracted.

### **⚠ DANGER**

#### **Risk of injury from ionizing radiation.**

Hazard for persons and the environment posed by ionizing radiation and contamination. Ionizing radiation and contamination could increase the risk of cancer and the risk of genetic birth defects. Depending on the dose received, ionizing radiation could lead to immediate physical harm, such as nausea, vomiting, hair loss, changes to blood count, serious tissue damage and even death.

- ▶ Never check the source holders directly.
- ▶ Carry out checks only on the rope separator and rope extension.

### **⚠ WARNING**

#### **Be aware of the risk of possible contamination.**

- ▶ Use appropriate personal protective equipment.
- ▶ Follow safety measures when putting away the rope extensions.

### **⚠ CAUTION**

#### **When the radiation sources are being raised, there is a risk of injury from rope defects on the rope extensions (e.g. due to frayed wire).**

This could result in personal injury in the form of cuts and abrasions.

- ▶ Wear protective equipment.

### 5.9.1 Source container is in the "Radiation switched on" state

1. Switch off the radiation (see the "Switching off the radiation" section)
2. When pulling back the rope extensions, wipe each rope along its entire length with suitable wipe test material

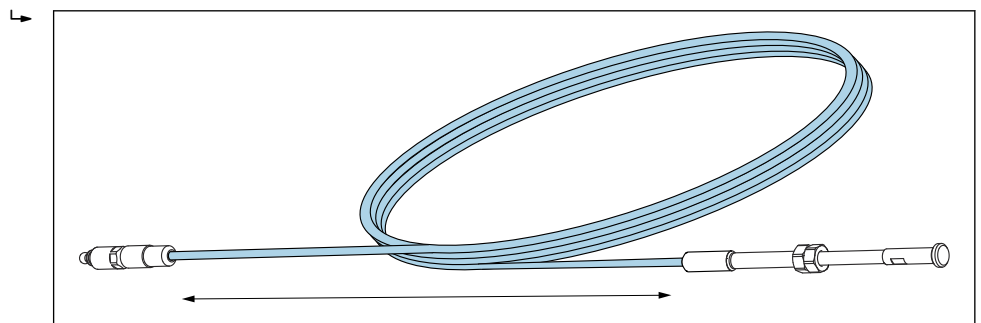

A0056014

3. When the "Switch off radiation" process is complete (cover not fitted), wipe the end of each source holder with suitable wipe test material
  - ↳ In doing so, pull the source holder back as far as it can go

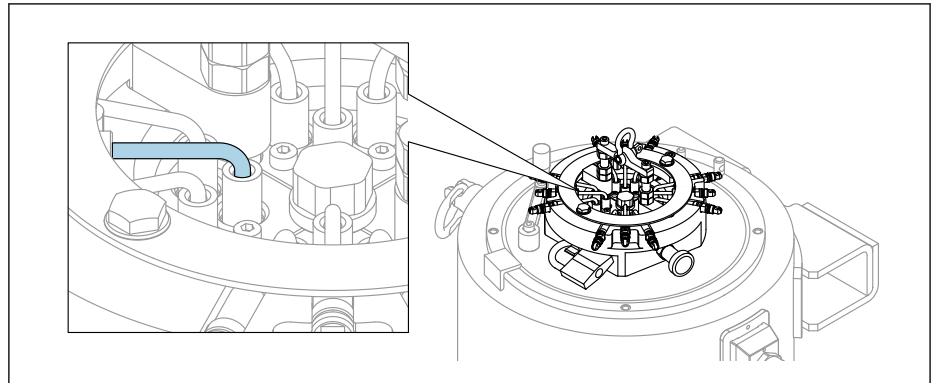

A0056015

4. Wipe around the insertion points of each source holder
  - ↳

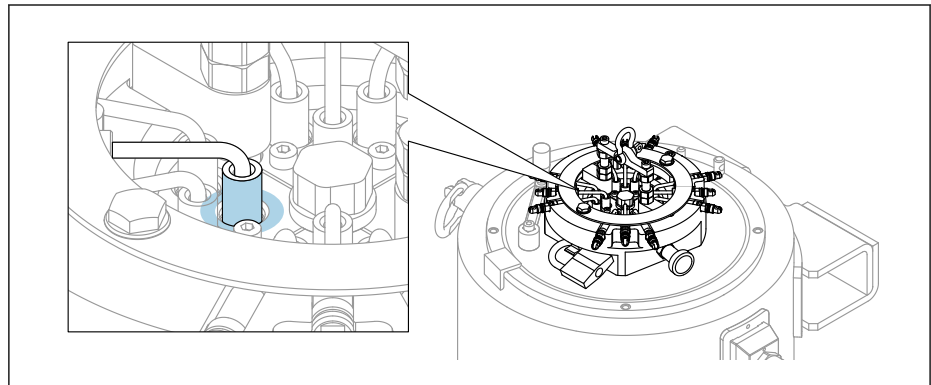

A0056016

5. Have the samples analyzed in a laboratory approved by the CNSC. A radiation source is considered to be leaking if more than 200 Bq (5.4 nCi) are detected in the leak test sample.

**⚠ WARNING**

**Risk of possible contamination**

The source capsule is potentially leaking. Contact with non-encapsulated, radioactive material can cause internal or external contamination, resulting in serious health risks and contamination of equipment, work areas or personnel.

- ▶ Stop using the device immediately.
- ▶ Contact the responsible radiation safety officer immediately for further instruction.
- ▶ Take appropriate measures to prevent a potential spread of radioactive contamination from the radiation source.
- ▶ Secure the radiation source.
- ▶ Notify the CNSC immediately that a leaking radiation source has been detected.

### 5.9.2 Source container is in the "Radiation switched off" state

1. Remove the cover

2. Wipe the end of each source holder with suitable wipe test material

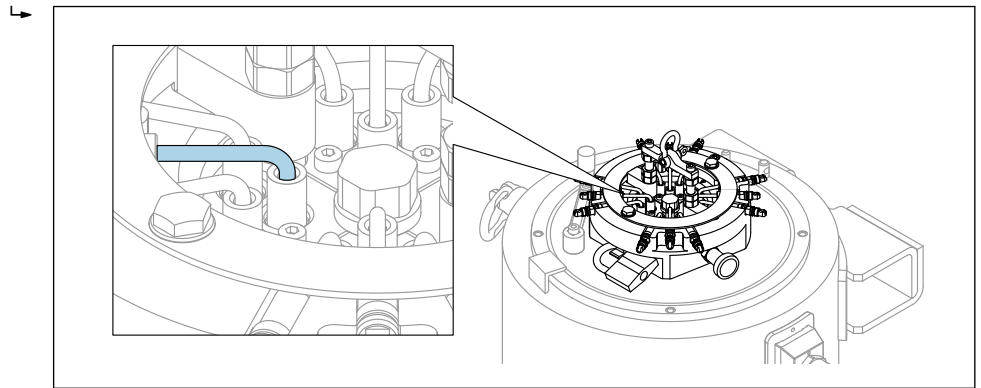

A0056015

3. Wipe around the insertion points of each source holder

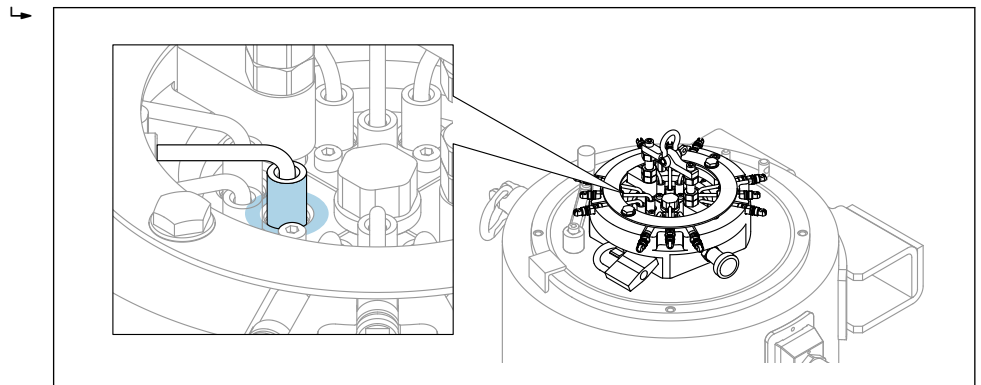

A0056016

4. Have the samples analyzed in a laboratory approved by the CNSC. A radiation source is considered to be leaking if more than 200 Bq (5.4 nCi) are detected in the leak test sample.

**⚠ WARNING**

**Risk of possible contamination**

The source capsule is potentially leaking. Contact with non-encapsulated, radioactive material can cause internal or external contamination, resulting in serious health risks and contamination of equipment, work areas or personnel.

- ▶ Stop using the device immediately.
- ▶ Contact the responsible radiation safety officer immediately for further instruction.
- ▶ Take appropriate measures to prevent a potential spread of radioactive contamination from the radiation source.
- ▶ Secure the radiation source.
- ▶ Notify the CNSC immediately that a leaking radiation source has been detected.

## 5.10 Source Container FQG74, rigid source magazine

**⚠ WARNING**

**Hot source magazine and hot rope extensions due to process heat transfer.**

This could result in burns to hands.

- ▶ Wear protective equipment.
- ▶ Define organizational measures for protection from hot parts. Warn equipment operators of the danger posed by hot parts on the source container, e.g. in the form of notices and training.
- ▶ The plant operator must ensure that the radiation sources can be safely set to the OFF position in an emergency. A risk of injury from hot parts on the source container must be taken into consideration.
- ▶ If possible, allow the process to cool down before the ropes are retracted.

**⚠ WARNING**

Be aware of the risk of possible contamination.

- ▶ Use appropriate personal protective equipment.
- ▶ Follow safety measures when putting away the rope extensions.

**⚠ CAUTION**

When the radiation sources are being raised, there is a risk of injury from rope defects on the rope extensions (e.g. due to frayed wire).

This could result in personal injury in the form of cuts and abrasions.

- ▶ Wear protective equipment.

### 5.10.1 Source container is in the "Radiation switched on" state

1. Switch off the radiation (see the "Switching off the radiation" section)
2. When pulling back the rope extensions, wipe each rope along its entire length with suitable wipe test material

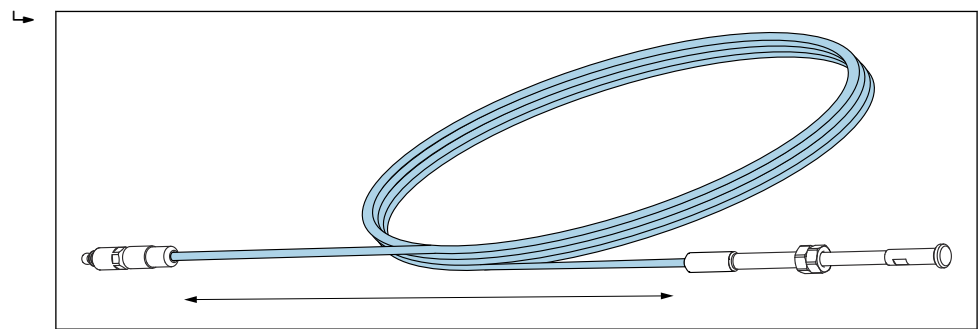

A0056014

3. When the "Switch off radiation" process is complete (cover not fitted), wipe the end of each source holder with suitable wipe test material
  - ↳ In doing so, pull the source holder back as far as it can go

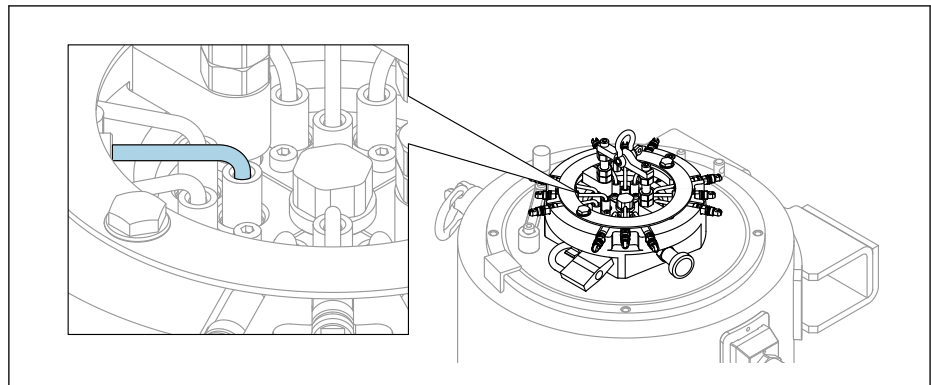

A0056015

4. Wipe around the insertion points of each source holder

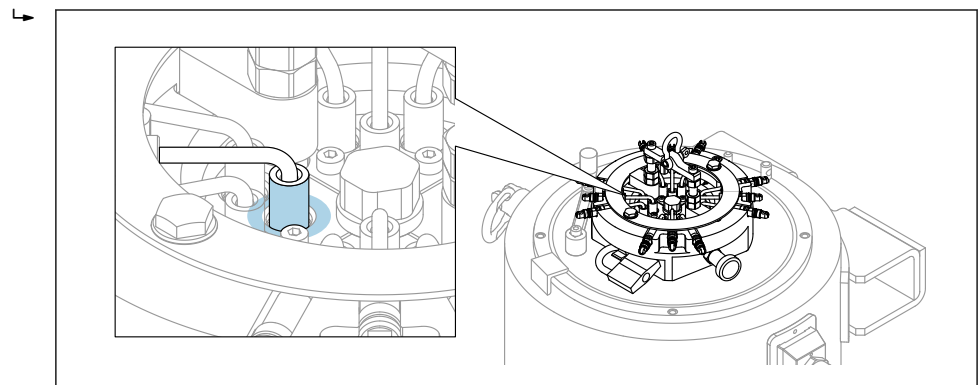

A0056016

5. Have the samples analyzed in a laboratory approved by the CNSC. A radiation source is considered to be leaking if more than 200 Bq (5.4 nCi) are detected in the leak test sample.

**⚠ WARNING**

**Risk of possible contamination**

The source capsule is potentially leaking. Contact with non-encapsulated, radioactive material can cause internal or external contamination, resulting in serious health risks and contamination of equipment, work areas or personnel.

- ▶ Stop using the device immediately.
- ▶ Contact the responsible radiation safety officer immediately for further instruction.
- ▶ Take appropriate measures to prevent a potential spread of radioactive contamination from the radiation source.
- ▶ Secure the radiation source.
- ▶ Notify the CNSC immediately that a leaking radiation source has been detected.

### 5.10.2 Source container is in the "Radiation switched off" state

1. Remove the cover
2. Wipe the end of each source holder with suitable wipe test material

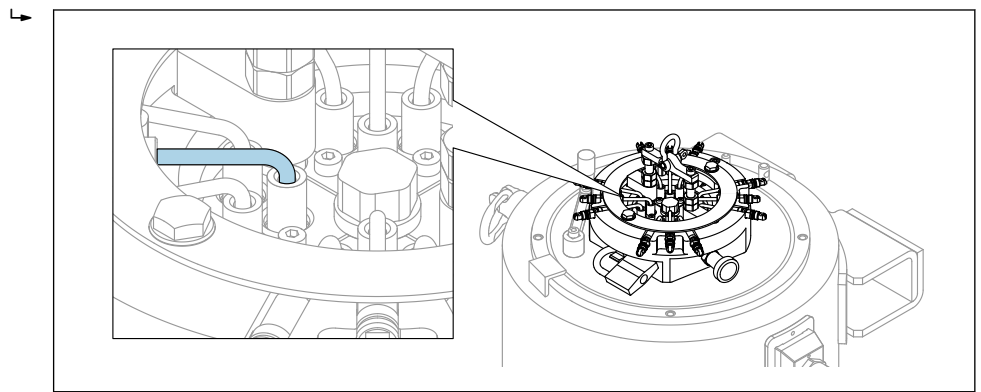

3. Wipe around the insertion points of each source holder

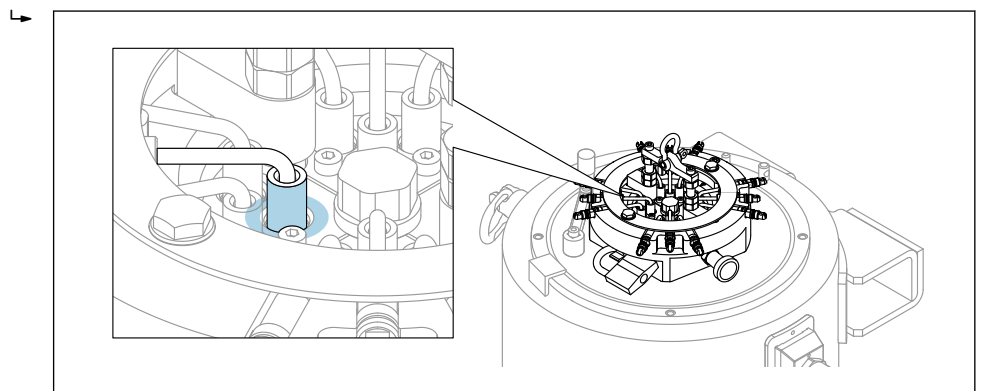

4. Have the samples analyzed in a laboratory approved by the CNSC. A radiation source is considered to be leaking if more than 200 Bq (5.4 nCi) are detected in the leak test sample.

**⚠ WARNING****Risk of possible contamination**

The source capsule is potentially leaking. Contact with non-encapsulated, radioactive material can cause internal or external contamination, resulting in serious health risks and contamination of equipment, work areas or personnel.

- ▶ Stop using the device immediately.
- ▶ Contact the responsible radiation safety officer immediately for further instruction.
- ▶ Take appropriate measures to prevent a potential spread of radioactive contamination from the radiation source.
- ▶ Secure the radiation source.
- ▶ Notify the CNSC immediately that a leaking radiation source has been detected.

## 5.11 Visual inspection

**i** The visual inspection is described in the maintenance section of the Operating Instructions for the source containers. The instructions contain a complete description of the required test steps, evaluation criteria and information on performing the test in accordance with the applicable regulations.

If a considerable amount of corrosion is visible at the housing (**FQG60**: especially in the area of the shutter plate; **FQG61/62**: especially at the cover plate of the beam exit channel), measure the radiation level around the device. If the values are significantly higher than those during normal operation, cordon off the area and immediately contact the radiation safety officer in charge for further instructions. Corroded devices or corroded parts of devices must always be replaced as soon as possible.

**For FQG63 and FQG74:** Source containers with a corroded extension, locking mechanisms or corroded rod on the slidable source holder must be replaced immediately.

**For FQG66:** especially at the cover plate of the beam exit channel and at the welding seams of the device base.

# 6 Emergency procedure

## 6.1 Purpose and overview

In the interests of personnel safety, the emergency procedure described here must be put into effect immediately to secure an area where an exposed radiation source is known, or suspected, to exist.

An emergency of this type occurs if a radioisotope is released due to detachment from the source container, if the source container's shutter cannot be closed, if the extension (where fitted) or the shutter cannot be moved to the 'AUS/OFF' position, or if fire has caused damage.

This procedure will safeguard the area until the radiation safety officer in charge can attend and advise on remedial action. The custodian of the radiation source (i.e. the person appointed and authorized by the customer) is responsible for observing this procedure.

## 6.2 Procedure for Source Container FQG60

1. Determine the affected area based on measurements (on site) or calculations, whereby the size and type of the installed radiation source can be found in the records.

2. Cordon off the danger zone at the boundary where radiation exposure exceeds 2.5  $\mu\text{Sv/h}$  (0.25 mR/h) with yellow marker tape or rope and mark it with international radiation warning signs.

**If a fire has occurred:**

- Assume that the lead shielding has partially melted.
- Inspect the area around the source container for damage to the mounting frame (bolts, brackets etc.).
- Inspect the damaged source container and compare the results with the inspection carried out during initial installation.
- If the source container housing is badly damaged, carry out a leak test on the source container to check for removable contaminants.

**If the shutter cannot be closed:**

- If part of the area is accessible (e.g., if a level transmitter is installed in a container, making it possible for personnel to enter the container), the source container must be detached from its mounting frame and placed face down on the floor or positioned so that the beam exit channel is facing a thick wall. The weight of approx. 18 kg (39.7) allows for manual handling.
- Personnel must be behind the source container at all times, not in front of the beam exit channel (rectangular shutter plate).

If it is not possible to cordon off the entire area or if there is an immediate risk of the radiation source moving, it may be necessary to secure the radiation source by relocating it or providing additional shielding. Take into account the inverse square law here, i.e., radiation decreases quadratically with distance. The radiation source must only be handled with pliers or tongs and held as far away from the body as possible. The time required to carry out this procedure should be minimized by rehearsing it beforehand.

1. Inform the local Canadian Nuclear Safety Commission (CNSC) official on duty with responsibility for the area where the incident occurred and request immediate action. **Phone number: (613) 995-0479 (Ottawa)** This must be done as soon as possible, but no later than 24 hours after the incident is detected.
2. Following a thorough assessment of the damage, the CNSC inspector and Endress+Hauser will agree on remedial action for the specific problem.

### 6.3 Procedure for Source Container FQG61/FQG62

1. Determine the affected area based on measurements (on site) or calculations, whereby the size and type of the installed radiation source can be found in the records.
2. Cordon off the danger zone at the boundary where radiation exposure exceeds 2.5  $\mu\text{Sv/h}$  (0.25 mR/h) with yellow marker tape or rope and mark it with international radiation warning signs.

**If a fire has occurred:**

- Assume that the lead shielding has partially melted.
- Inspect the area around the source container for damage to the mounting frame (bolts, brackets etc.).
- Inspect the damaged source container and compare the results with the inspection carried out during initial installation.
- If the source container housing is badly damaged, carry out a leak test on the source container to check for removable contaminants.
- Check that the shutter mechanism is functioning properly.

**If the shutter cannot be closed:**

- If part of the area is accessible (e.g., if a level transmitter is installed in a container, making it possible for personnel to enter the container), the source container must be detached from its mounting frame and placed face down on the floor or positioned so that the beam exit channel is facing a thick wall. The ring-eyelet on the housing enables safe handling.
- Personnel must be behind the source container at all times and not in front of the beam exit channel (flange).

If the shutter cannot be closed due to a failure of the pneumatic drive:

Switch off or disconnect the compressed air, disconnect supply lines if necessary. Open the lower padlock, release the Allen screws next to the pneumatic drive and remove the entire drive unit to access the source holder. Manually turn the source holder to the position marked 'Off'.

If it is not possible to cordon off the entire area or if there is an immediate risk of the radiation source moving, it may be necessary to secure the radiation source by relocating it or providing additional shielding. Take into account the inverse square law here, i.e., radiation decreases quadratically with distance. The radiation source must only be handled with pliers or tongs and held as far away from the body as possible. The time required to carry out this procedure should be minimized by rehearsing it beforehand.

1. Inform the local Canadian Nuclear Safety Commission (CNSC) official on duty with responsibility for the area where the incident occurred and request immediate action. **Phone number: (613) 995-0479 (Ottawa)** This must be done as soon as possible, but no later than 24 hours after the incident is detected.
2. Following a thorough assessment of the damage, the CNSC inspector and Endress+Hauser will agree on remedial action for the specific problem.

## 6.4 Procedure for Source Container FQG63/FQG74

1. Determine the affected area based on measurements (on site) or calculations, whereby the size and type of the installed radiation source can be found in the records.
2. Cordon off the danger zone at the boundary where radiation exposure exceeds 2.5  $\mu\text{Sv/h}$  (0.25 mR/h) with yellow marker tape or rope and mark it with international radiation warning signs.

**If a fire has occurred:**

- Assume that the lead shielding has partially melted.
- Inspect the area around the source container for damage to the mounting frame (bolts, brackets etc.).
- Inspect the damaged source container and compare the results with the inspection carried out during initial installation.
- If the source container housing is badly damaged, carry out a leak test on the source container to check for removable contaminants.
- Check that the shutter mechanism is functioning properly.

**If the shutter cannot be closed:**

If the extension is retracted but the turnable source holder does not close:

- If part of the area is accessible (e.g., if a level transmitter is installed in a container, making it possible for personnel to enter the container), the source container (extension in 'AUS/OFF' position) must be detached from its mounting frame and placed face down on the floor or positioned so that the beam exit channel is facing a thick wall. The ring-eyelet on the housing enables safe handling.
- Personnel must be behind the source container at all times, not in front of the beam exit channel (rectangular shutter plate).

If the extension cannot be retracted:

If part of the area is accessible (e.g., if a level transmitter is installed in a container, making it possible for personnel to enter the container), the source container must be unscrewed, removed from the mounting frame with the protection pipe and placed face down on the floor. The protection pipe must be completely covered with a suitable shielding immediately.

Personnel must maintain the greatest possible distance to the protection pipe at all times and always remain behind the source container, never in front of the beam exit channel (flange on the source container) or near the extension or protection pipe. The ring-eyelets on the housing enable safe handling.

If it is not possible to cordon off the entire area or if there is an immediate risk of the radiation source moving, it may be necessary to secure the radiation source by relocating it or providing additional shielding. Take into account the inverse square law here, i.e., radiation decreases quadratically with distance. The radiation source must only be handled with pliers or tongs and held as far away from the body as possible. The time required to carry out this procedure should be minimized by rehearsing it beforehand.

1. Inform the local Canadian Nuclear Safety Commission (CNSC) official on duty with responsibility for the area where the incident occurred and request immediate action. **Phone number: (613) 995-0479 (Ottawa)** This must be done as soon as possible, but no later than 24 hours after the incident is detected.
2. Following a thorough assessment of the damage, the CNSC inspector and Endress+Hauser will agree on remedial action for the specific problem.

## 6.5 Procedure for Source Container FQG66

1. Determine the affected area based on measurements (on site) or calculations, whereby the size and type of the installed radiation source can be found in the records.
2. Cordon off the danger zone at the boundary where radiation exposure exceeds 2.5  $\mu\text{Sv/h}$  (0.25 mR/h) with yellow marker tape or rope and mark it with international radiation warning signs.

### If a fire has occurred:

- Assume that the lead shielding has partially melted.
- Inspect the area around the source container for damage to the mounting frame (bolts, brackets etc.).
- Inspect the damaged source container and compare the results with the inspection carried out during initial installation.
- If the source container housing is badly damaged, carry out a leak test on the source container to check for removable contaminants.
- Check that the shutter mechanism is functioning properly.

### If the shutter cannot be closed:

- If part of the area is accessible (e.g., if a level transmitter is installed in a container, making it possible for personnel to enter the container), release the source container from its mounting frame and
  - if the beam exit channel is horizontal: point the beam exit channel towards a very thick wall, or
  - if the beam exit channel is vertical: place the source container on its device base on the floor.
- Personnel must be behind the source container at all times, not in front of the beam exit channel (rectangular shutter plate).

**⚠ WARNING**

**Source container not fitted to the crane correctly, leading to possible falling of the source container.**

This could result in personal injury or even death as a consequence of impact.

- ▶ Wear protective equipment.
- ▶ Lifting accessories must be suitably rated for the gross weight.

Use lifting equipment as the weight is approx. 435 kg (959.18 lb).

If the shutter cannot be closed due to a failure of the pneumatic drive:

Switch off or disconnect the compressed air, disconnect supply lines if necessary. Remove the protective cap. Release the connecting screw between the ring-eyellet at the end of the slidable source holder and the pneumatic drive. Move the slidable source holder to the "AUS/OFF" position and secure it with the locking pin.

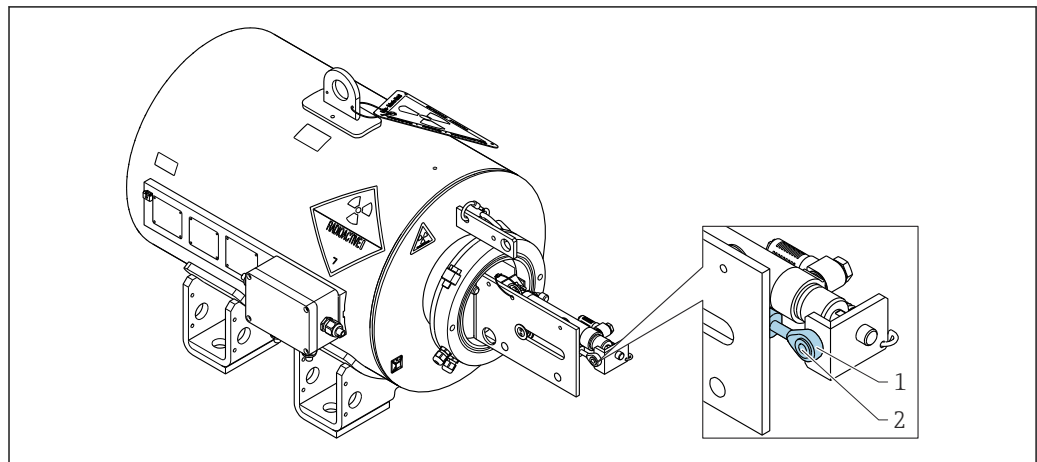

A0027945

- 1 Ring-eyellet  
2 Connecting screw

If it is not possible to cordon off the entire area or if there is an immediate risk of the radiation source moving, it may be necessary to secure the radiation source by relocating it or providing additional shielding. Take into account the inverse square law here, i.e., radiation decreases quadratically with distance. The radiation source must only be handled with pliers or tongs and held as far away from the body as possible. The time required to carry out this procedure should be minimized by rehearsing it beforehand.

1. Inform the local Canadian Nuclear Safety Commission (CNSC) official on duty with responsibility for the area where the incident occurred and request immediate action. **Phone number: (613) 995-0479 (Ottawa)** This must be done as soon as possible, but no later than 24 hours after the incident is detected.
2. Following a thorough assessment of the damage, the CNSC inspector and Endress+Hauser will agree on remedial action for the specific problem.









71756207

[www.addresses.endress.com](http://www.addresses.endress.com)

---