

Installation Instructions

Liquiline System CA8x analyzer

Electronic parts















Table of contents

1	Overview	3
2	Intended use	11
3	Personnel authorized to carry out conversion	12
4	Safety instructions	12
5	Overview and handling the spare parts kits	14
6	Scope of delivery	15
7	Replacing the components	21
8	Additional documentation	43
9	Disposal	43

1 Overview





1.1 Spare parts kits

These installation instructions apply to the following spare parts kits:

Order code	Description	Page
71218419	CA8x M12 Socket for digital sensor	→  15
71218503	CA8x Power unit 100–240 V AC	→  15
71218505	CA8x Power unit 24 V DC (DC/DC converter)	→  16
71218507	CA8x Interface module (version 1)	→  16
71465480	CA8x Interface module (version 2)	→  17
71239304	CA8x Backplane CM44 (version 1)	→  17
71401272	CA8x Backplane CM44 (version 2)	→  17
71141366	CA8x Extension backplane module	→  18
71239305	CA8x BASE-E base module	→  19
71431302	CA8x BASE2-E base module	→  19
71218486	CA8x Housing fan, complete	→  20
71389529	CA8x photometer electronics	→  20

1.2 Overview of CA8x device types

1.2.1 Overview of CA80 single parameters (CA80AL/AM/CR/FE/HA/NO/PH)

The figures below (→  1,  4 and →  2,  5) show an overview of the CA80 for the colorimetric single parameter measurement:

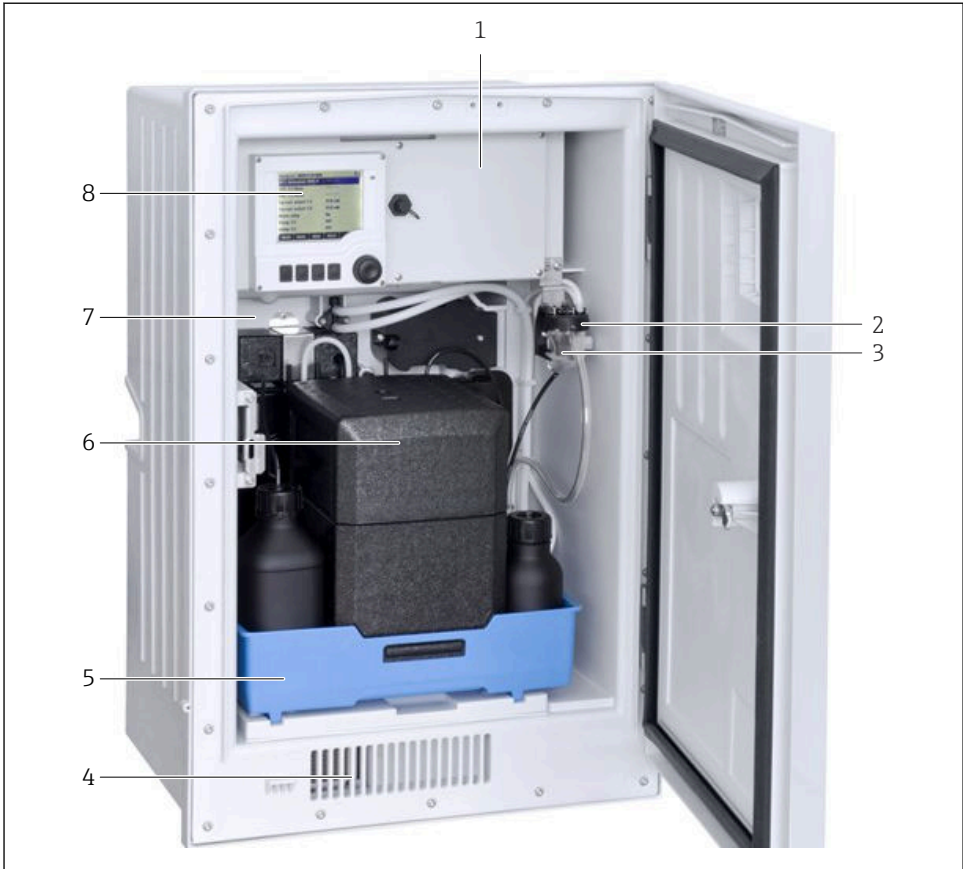

A0057624

1 Overview of single parameters for CA80 assemblies

- 1 Electronics compartment cover
- 2 Solenoid valve (only for 2x sample collector)
- 3 Sample collector (depending on version ordered)
- 4 Ventilation/cooling
- 5 Bottle tray
- 6 Insulation (optional, only for cooling)
- 7 Process module (carrier plate with Liquid Manager, photometer and control module)
- 8 Measuring and control unit (controller)

The figure below shows the carrier plate from the front.

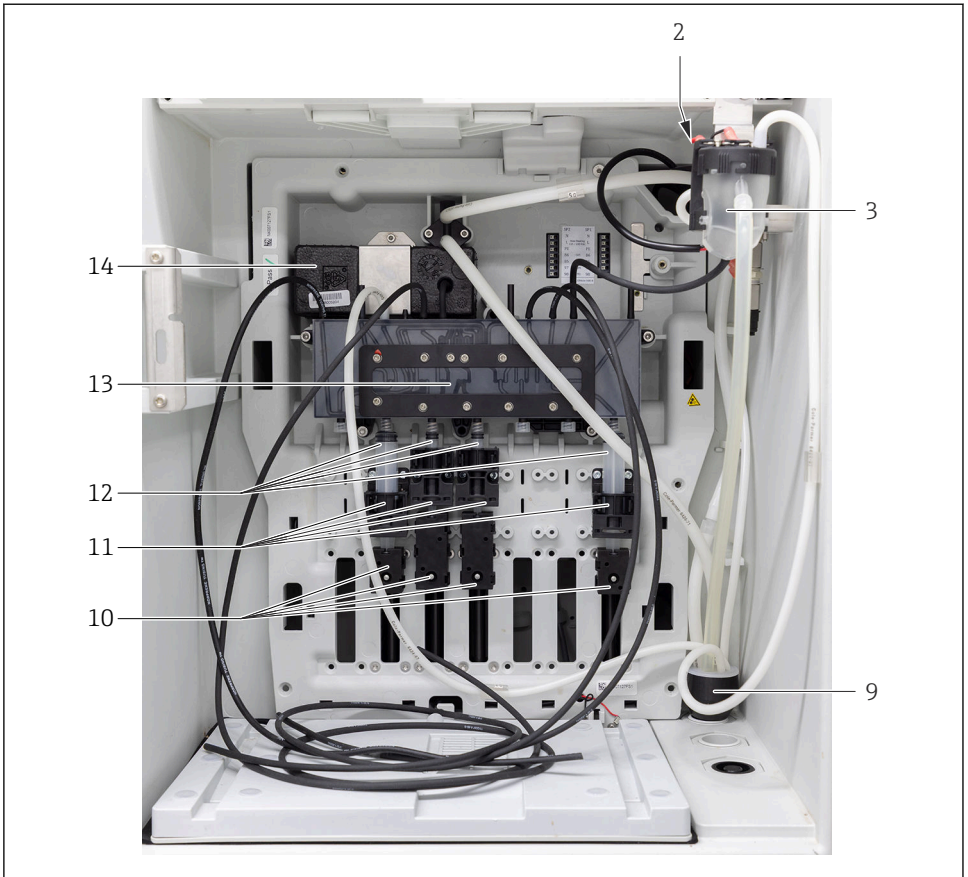





A0056794

📷 2 Carrier plate for CA80 single parameters

- 9 Drain pipe
- 10 Linear drives
- 11 Dispenser holders
- 12 Dosing dispensers
- 13 Liquid Manager
- 14 Photometer

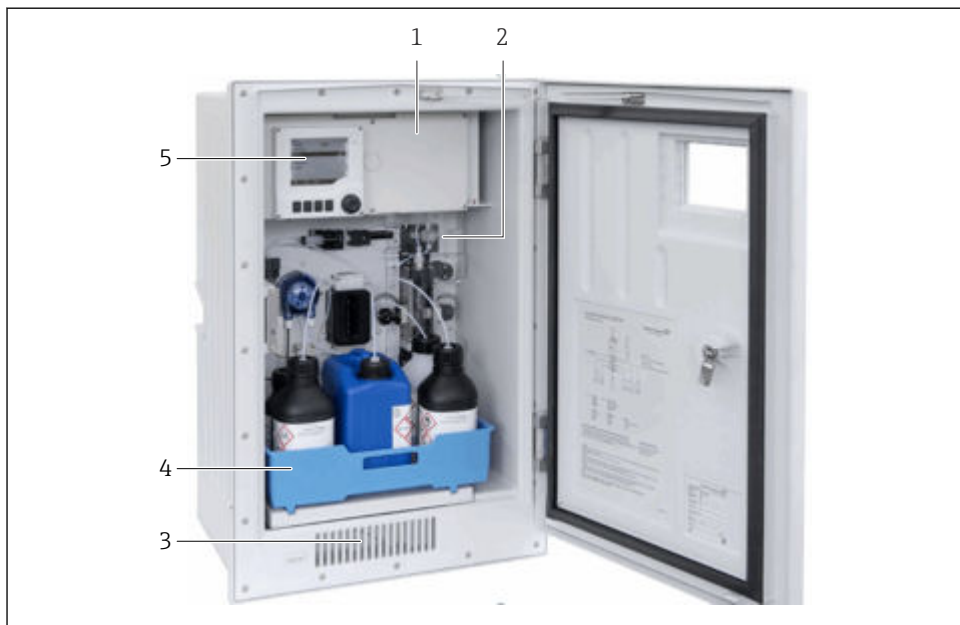

1.2.2 Overview of CA80 sum parameters (Liquiline System CA80COD/TP)

The figures below (→  3,  6 and →  4,  7) show an overview of the CA80 for the colorimetric sum parameter measurement.



A0057629





3 Assembly overview of Liquiline System CA80COD sum parameters

- 1 Electronics compartment
- 2 Carrier plate →  4,  7
- 3 Cooling (option for Liquiline System CA80TP)
- 4 Bottle tray for reagents and standard
- 5 Measuring and control unit (controller)

The figure below shows the carrier plate from the front.

- 20 Sample intake
- 21 Sample pump
- 22 Dilution module (only with high measuring range)
- 23 Dosing dispenser

1.2.3 Overview of CA80SI/82HA

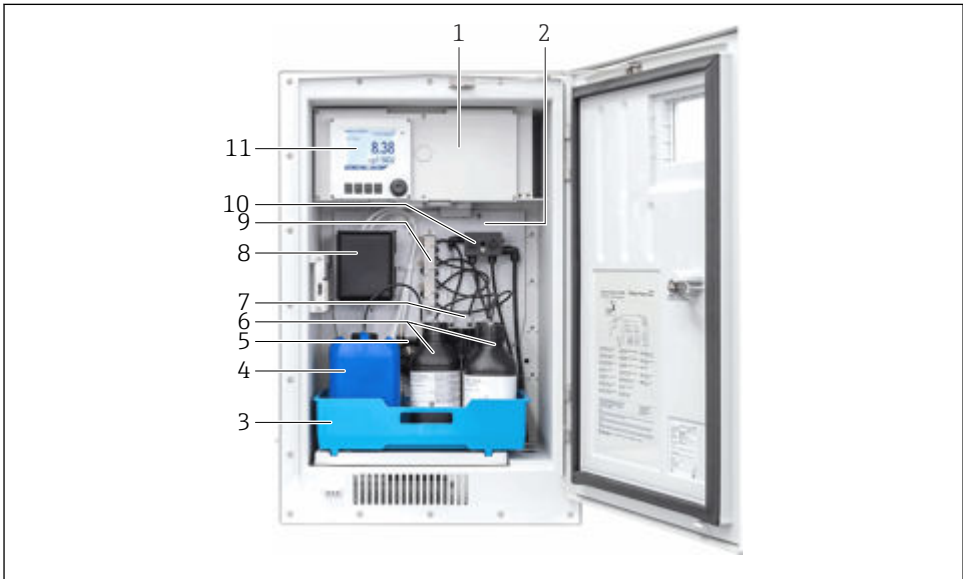

The figures below (→  5,  8 and →  6,  9) show an overview of the CA80SI/82HA for photometric silicate measurement or to measure water hardness in the low validity range. A 2-channel device is shown.

For 2-channel devices, the sample switch is integrated into the device. Filters and pressure limiters are mounted externally.



A0057631

 5 CA80SI/82HA assembly overview

- 1 Electronics compartment cover
- 2 Carrier plate →  6,  9
- 3 Bottle tray
- 4 Bottle for standard solution
- 5 Peristaltic pump for standard solution
- 6 Reagent bottles
- 7 Dosing dispensers for reagents
- 8 Cover with cuvette, photometer and stirrer behind
- 9 Valve block for reagent dosing
- 10 Sample switch (only 1-channel/2-channel devices)
- 11 Measuring and control device

The figure below shows the carrier plate from the front.

For 4-channel/6-channel devices, the sample switch is outside the analyzer.

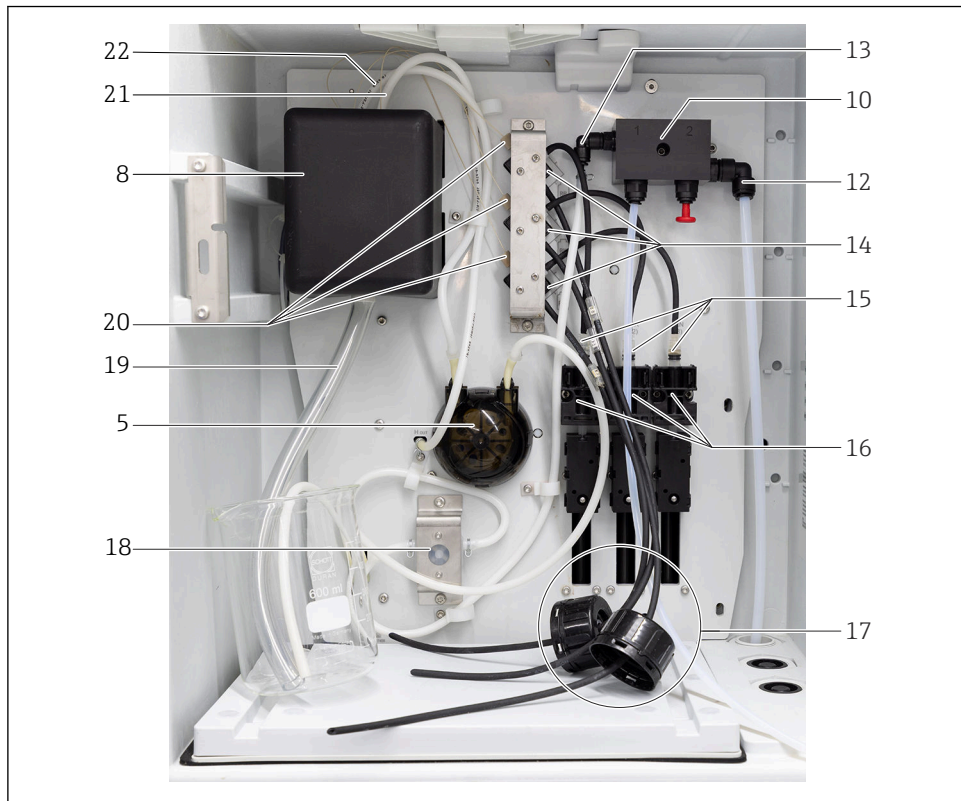





A0058795

6 CA80SI/82HA carrier plate

- 12 Drain hose sample switch OD 8 mm
- 13 Sample hose for 1-channel/2-channel devices to heater
- 14 Valves for reagents
- 15 Dosing dispensers
- 16 Dispenser holders
- 17 Cover of reagent container with hoses
- 18 Flowmeter
- 19 Drain hose, cuvette ID 13 mm
- 20 Capillaries for reagents
- 21 Sample hose (from heater)
- 22 Hose standard solution



1.2.4 Overview of Liquiline System CA80TN (total nitrogen)

The figures below (→  7,  10 and →  8,  11) show an overview of the Liquiline System CA80TN for the photometric measurement of the total nitrogen.



A0057730

7 *Liquiline System CA80TN assembly overview*

- 1 *Electronics compartment cover*
- 2 *Carrier plate →  8,  11*
- 3 *Peristaltic pump*
- 4 *Valve block for reagent dosing*
- 5 *Bottle tray for reagents, sample + standard*
- 6 *Reactor (behind protective cover)*
- 7 *Protective cover*
- 8 *Measuring and control device*

The figure below shows the carrier plate from the front.

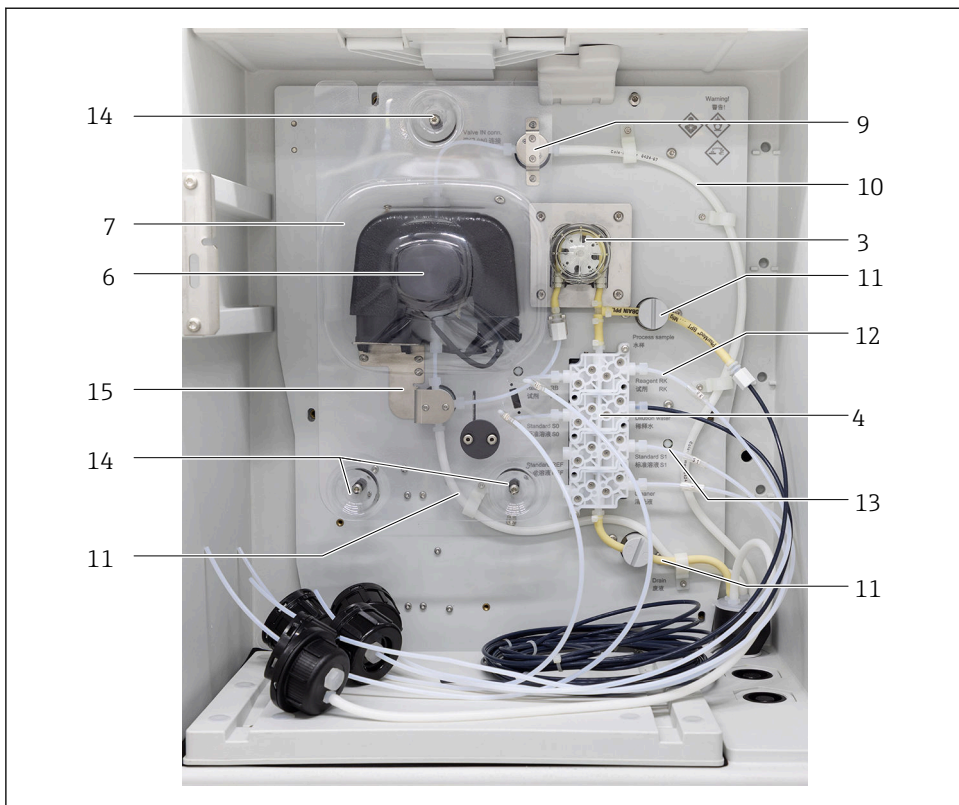

A0058796

8 *Liquiline System CA80TN carrier plate*

- 9 *Vent valve*
- 10 *Ventilation hose*
- 11 *Drain hoses*
- 12 *Sample hose*
- 13 *Dilution water hose*
- 14 *Screws of protective cover*
- 15 *Reactor valve*

2 **Intended use**

- The parts of the kits must only be used as spare parts for CA8x analyzers. Any other use is not permitted!
- Use only original parts from Endress+Hauser.
- In the Device Viewer, check if the spare part is suitable for the device in question.

3 Personnel authorized to carry out conversion

- Installation, commissioning, operation and maintenance of the measuring system may be carried out only by specially trained technical personnel.
- The technical personnel must be authorized by the plant operator to perform the stated tasks.
- The electrical connection may only be established by an electrical technician.
- The technical personnel must have read and understood these Installation Instructions and must follow the instructions they contain.
- Measuring point faults may be repaired only by authorized and specially trained personnel.
- In the case of Ex-certified devices, the technical staff must also be trained in explosion protection.

 Repairs not described in the Operating Instructions provided must only be carried out directly at the manufacturer's site or by the service organization.

4 Safety instructions

WARNING

Risk of death due to electric shock!

- ▶ Perform work on the device with the utmost caution, especially when the device remains fully or partially powered on during maintenance tasks.
- ▶ The analyzer has no power switch. If necessary, use the system-side circuit breaker.
- ▶ Follow the instructions in the relevant chapters of this manual, as the procedure for electrical safety depends on the service kits used.
- ▶ All work must be carried out according to applicable safety standards.
- ▶ Follow the instructions in the Operating Instructions for the device.

CAUTION

Risk to health due to contact with reagents, chemicals or process solutions!

- ▶ Wear protective gloves, protective goggles and protective clothing.
- ▶ Immediately rinse splashes with plenty of water and a 1% sodium bicarbonate solution (NaHCO_3 , baking soda).
- ▶ In case of eye contact, rinse the affected area with plenty of water and then seek medical advice. Show the relevant safety data sheet to the physician.
- ▶ Note the nationally applicable workplace safety regulations for the work area when handling toxic or corrosive chemicals.

⚠ CAUTION**Electronic assemblies are sensitive to electrostatic discharges (ESD)!**

- ▶ Before removing an assembly from the antistatic packaging, it must be discharged, e.g. at a protective ground. Continuous grounding, e.g. with an ESD wristband, is recommended.

 Potential impact on the process

Before decommissioning an active device, the potential impact on the overall process must be taken into account! This applies in particular when using the switching contacts, the analog signal outputs or the communication interface of the associated measuring instrument to control process variables. Coordinate service tasks with the operator!

- ** Contact Endress+Hauser Service if you have questions: www.addresses.endress.com

4.1 Compatibility of the electrical assemblies

If one of the modules specified in the table below needs to be replaced, care must be taken to use a module of the same version. A device's generation of modules can be determined in the Asset Central Viewer (ACV).

Electronic modules of Version 1 are not compatible with electronic modules of Version 2. This means that a device can only contain either Version 1 modules or Version 2 modules, but not a mix of both. The table shows the compatibility of modules.

Version 2 of the electronics modules is only supported by firmware 01.08.00 and later!

	Backplane V1	BASE-E	Interface module V1	Control module V1	Backplane V2	BASE2-E	Interface module V2	Control module V2
Backplane V1	N/A	☑	☑	☑	N/A	-	-	-
BASE-E	☑	N/A	☑	☑	-	N/A	-	-
Interface module V1	☑	☑	N/A	☑	-	-	N/A	-
Control module V1	☑	☑	☑	N/A	-	-	-	N/A
Backplane V2	N/A	-	-	-	N/A	☑	☑	☑
BASE2-E	-	N/A	-	-	☑	N/A	☑	☑
Interface module V2	-	-	N/A	-	☑	☑	N/A	☑
Control module V2	-	-	-	N/A	☑	☑	☑	N/A

CA80	Name @ ACV	Module name	Spare parts kit
All	FIDC1 + FXHC1	BASE-E module	71239305 CA8x BASE-E base module
	FIDC1 + FXHC2	BASE2-E module	71431302 BASE2-E base module

CA80	Name @ ACV	Module name	Spare parts kit
	FIDS1	Interface mod. V1	71218507 CA8x Interface module (version 1)
	FIDS2	Interface mod. V2	71465480 CA8x Interface module (version 2)
	FC4W2	Backplane V1	71239304 CA8x Backplane CM44 (version 1)
	FC4W3	Backplane V2	71401272 Kit CA8x backplane CM44 (version 2)
CA80AL/AM/CR/FE/HA/NO/PH	FXAB1	Control module V1	71218504 Kit CA8x FXAB1 control module
	FXAB2	Control module V2	71503207 Kit CA8x control module version 2
Liquiline System CA80COD/TP	FMAB1 (FXAB1 with AXIO1)	Control module V1	71324197 Kit Liquiline System CA80COD/TP control module FMAB1
	FMAB2 (FXAB2 with AXIO1)	Control module V2	71503213 Kit Liquiline System CA80COD/TP control module Vers. 2
CA80SI/82HA	FMAB1 (FXAB1 with AXIO1)	Control module V1	N/A
	FMAB2 (FXAB2 with AXIO1)	Control module V2	71503211 Kit CA80SI/82HA control module version 2
Liquiline System CA80TN	FMAB2 (FXAB2 with AXIO1)	Control module V2	71503214 Kit Liquiline System CA80TN control module version 2

5 Overview and handling the spare parts kits

The spare parts kits in this manual are suitable for all the devices from the CA8x family. An overview of the main device types is provided in the “Overview of CA8x device types” section →  3.

All replacement descriptions for the kits refer to the “CA80 single parameter” device type (CA80AL/AM/CR/FE/HA/NO/PH).

The Liquiline System CA80COD/TP/TN and CA80SI/82HA device types have a partial structural difference. However, the spare parts kits of this manual are not significantly affected. **Simply apply the individual replacement instructions accordingly.**

6 Scope of delivery

6.1 7128419 Kit CA8x M12 socket for digital sensor

The kit contains the following parts →  9,  15:

- | | | | |
|-----|-------------------------|-----|------------------|
| 1 x | M12 socket with cable | 1 x | Kit instructions |
| 1 x | Shield connection cable | | |

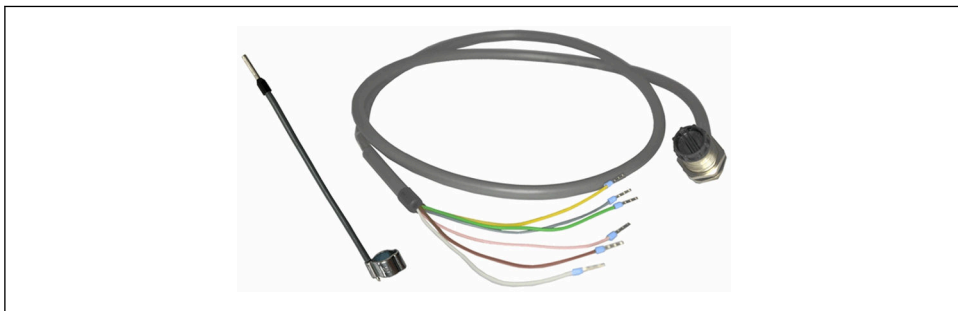

A0058596

 9 *M12 Socket for digital sensor*

6.2 71218503 Kit CA8x power unit 100–240 V AC

The kit contains the following parts →  10,  15:



- | | | | |
|-----|--------------------------------------|-----|------------------|
| 1 x | Power unit 100–240 V AC for DIN rail | 1 x | Kit instructions |
|-----|--------------------------------------|-----|------------------|



A0058597

 10 *Power unit 100–240 V AC*

6.3 71218505 Kit CA8x power unit 24 V DC (DC/DC converter)

The kit contains the following parts →  11,  16:



- | | | | |
|-----|-----------------------------------|-----|------------------|
| 1 x | DC/DC converter 24 V for DIN rail | 1 x | Kit instructions |
|-----|-----------------------------------|-----|------------------|



A0058598

-  11 Power unit 24 V (DC/DC converter)

6.4 71218507 Kit CA8x interface module (version 1)

The kit contains the following parts →  12,  16:

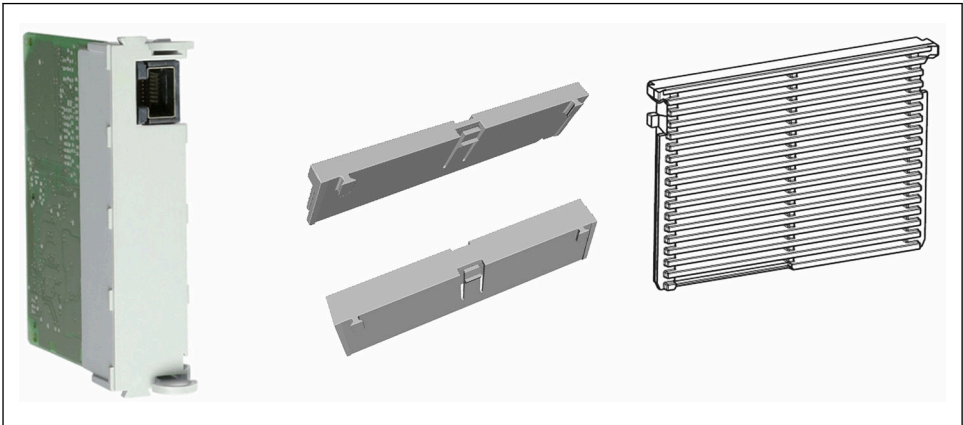

- | | | | |
|-----|--|-----|---------------------------|
| 1 x | Analyzer interface module, FIDS1 module
(Version 1, without labeling) | 1 x | Module dummy cover, 12 mm |
| 1 x | Module end cover | 1 x | Kit instructions |
| 1 x | Module dummy cover, 6 mm | | |



A0058599

-  12 Interface module (version 1)

6.5 71465480 Kit CA8x interface module (version 2)

The kit contains the following parts →  13,  17:

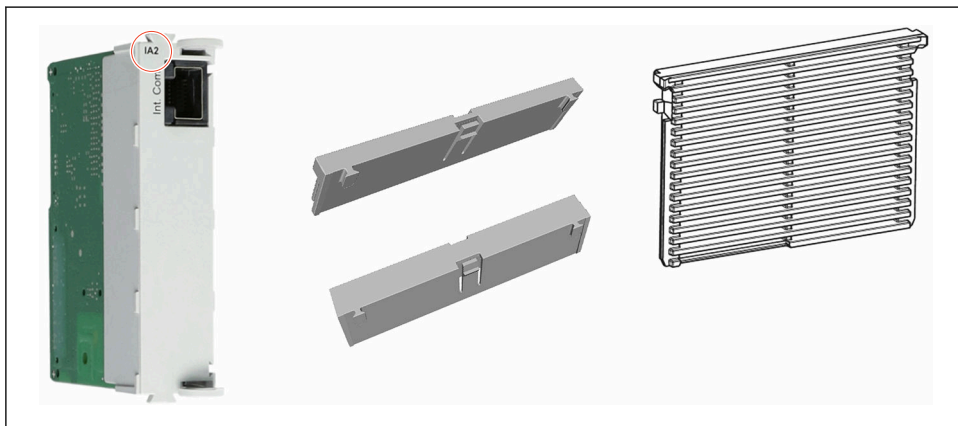

1 x	Analyzer interface module, FIDS2 module (Version 2, labeling: IA2)	1 x	Module dummy cover, 12 mm
1 x	Module end cover	1 x	Kit instructions
1 x	Module dummy cover, 6 mm		



A0058477



 13 *Interface module (version 2)*

6.6 71239304 Kit CA8x backplane CM44 (version 1)

The kit contains the following parts →  14,  18, left:

1 x	Backplane module FC4W2 with battery	1 x	Kit instructions
-----	-------------------------------------	-----	------------------

6.7 71401272 CA8x Backplane CM44 (version 2)

The kit contains the following parts →  14,  18, right:

1 x	Backplane module FC4W3 with battery	1 x	Kit instructions
-----	-------------------------------------	-----	------------------

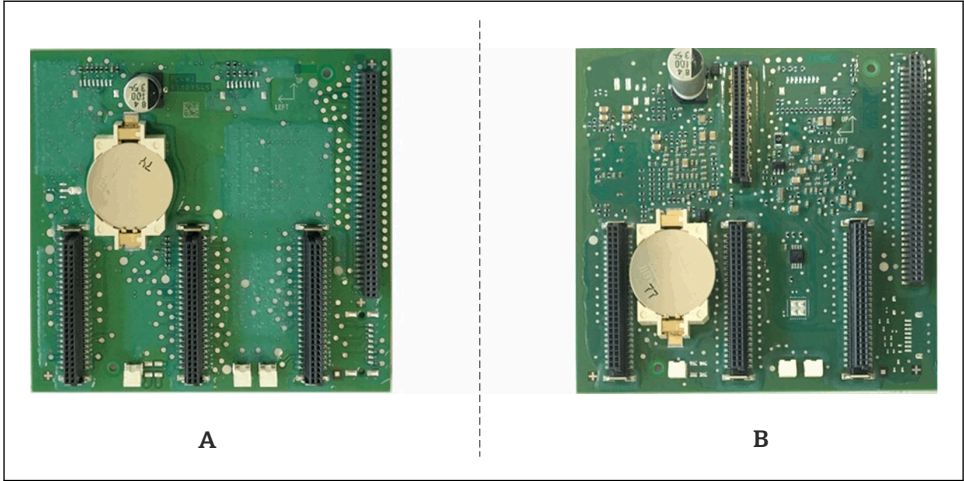

A0058479

14 Backplane module CM44

A Backplane module version 1

B Backplane module version 2

6.8 71141366 Kit CA8x extension backplane module

The kit contains the following parts → 15, 18:

1 x Extension backplane

1 x Kit instructions

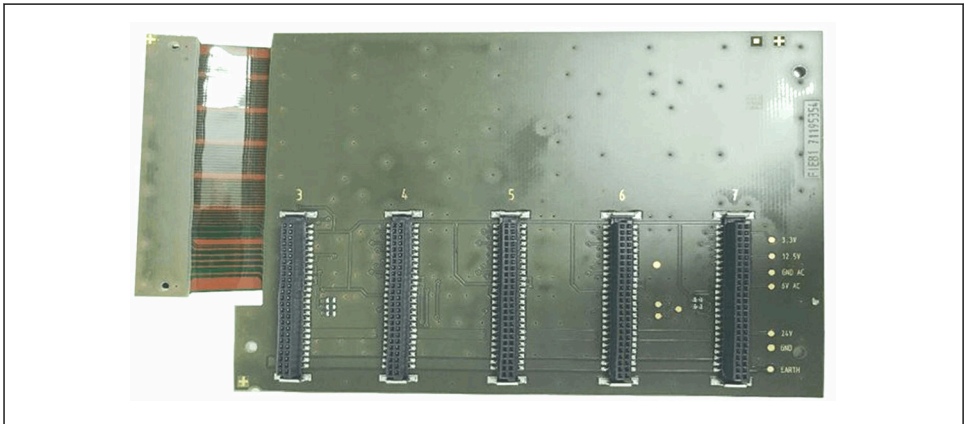

A0058600

15 Extension backplane module

6.9 71239305 Kit CA8x BASE-E base module

The kit contains the following parts →  16,  19:

- | | | | |
|-----|-----------------------------|-----|---------------------------|
| 1 x | BASE-E module (FXHC1+FIDC1) | 1 x | Module dummy cover, 12 mm |
| 1 x | Module end cover | 1 x | Kit instructions |
| 1 x | Module dummy cover, 6 mm | | |

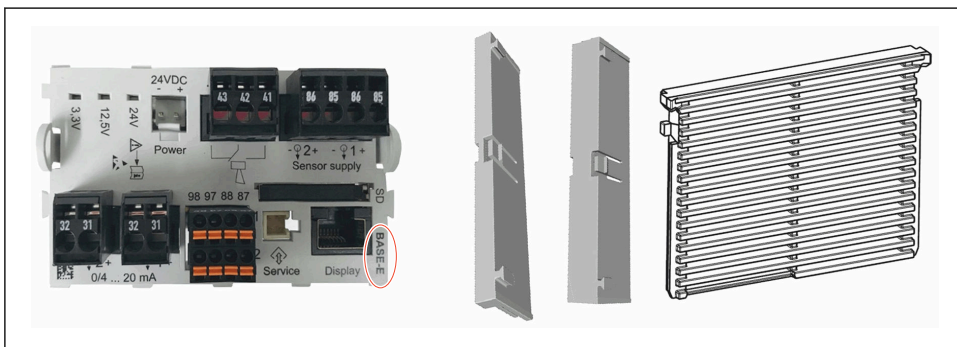

A0058482

 16 *BASE-E base module*

6.10 71431302 Kit CA8x BASE2-E base module

The kit contains the following parts →  17,  19:

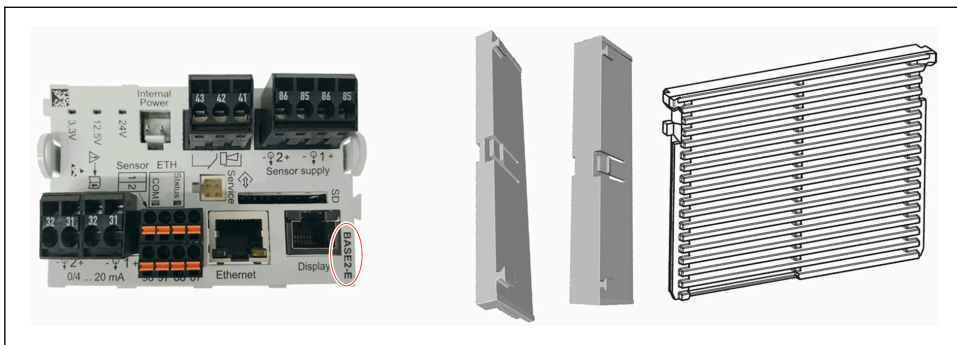

- | | | | |
|-----|----------------------------------|-----|---------------------------|
| 1 x | BASE2-E base module FXHC2+FIDC1) | 1 x | Module dummy cover, 12 mm |
| 1 x | Module end cover | 1 x | Kit instructions |
| 1 x | Module dummy cover, 6 mm | | |



A0058483

 17 *BASE2-E base module*

6.11 71218486 Kit CA8x housing fan, complete

The kit contains the following parts →  18,  20:



- | | | | |
|-----|------------------------------------|-----|------------------|
| 1 x | Housing fan 120 x 120 mm, complete | 1 x | Kit instructions |
|-----|------------------------------------|-----|------------------|



A0058601

-  18 *Housing fan, complete*

6.12 71389529 Kit CA8x photometer electronics

The kit contains the following parts →  19,  20:

- | | | | |
|-----|-----------------------------------|-----|------------------|
| 1 x | Photometer electronics FSFC1 | 3 x | Washer PA |
| 3 x | Torx screw M3x35, stainless steel | 1 x | Kit instructions |

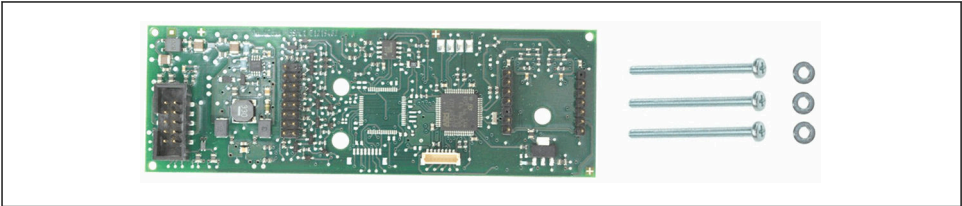



A0058752

-  19 *CA8x photometer electronics*

7 Replacing the components

7.1 Preparation

The spare part installation differs depending on the spare part and parameters. Therefore, refer to and differentiate between Section 1.2.1 →  3 to 1.2.4 →  10.

7.1.1 Work without removing the chemical containers = replacing modules/ components in the electronics compartment

1. Select **Mode** → **Manual mode** and confirm by pressing the navigator button.
2. Wait until the analyzer has finished the measurement and **Manual** is displayed as the “Current mode”.
3. **Disconnect the analyzer from the power supply!** Secure the circuit breaker against unintentional recommissioning.

7.1.2 Work with removal of chemical containers = replacing components on or behind the carrier plate for CA80AL/AM/CR/FE/HA/NO/PH

1. Select **Mode** → **Manual mode** and confirm by pressing the navigator button.
2. Wait until the analyzer has finished the measurement and **Manual** is displayed as the “Current mode”.
3. Stop the sample feed from the sample preparation system.
4. Select **Menu** → **Operation** → **Maintenance** → **Decommissioning** → **Sample collector** → **Empty sample collector**. Wait until the sample collecting vessel is empty.
5. Remove all the hoses from the reagent bottles. Wipe the ends of the hoses with a clean paper towel and place the hoses in an empty beaker. Select the **Rinse with water** entry. The system is cleaned with air.



The software evaluates this as the bottles being removed. Therefore, they need to be reinserted at a later time.

6. Then place the hoses in a beaker containing distilled water or treated water.
7. Disconnect the black sample hose “P” from the sample collecting vessel and place it in the beaker.
8. Select **Menu** → **Operation** → **Maintenance** → **Decommissioning** → **Rinse with water**. Wait until rinsing is finished.
9. Place the hoses back into an empty beaker and flush again with air by selecting the **Rinse with water** entry.



All hoses, the Liquid Manager and the dispensers are now flushed, clean and filled with air. It is now possible to work on the analyzer without risk.

10. **Disconnect the analyzer from the power supply!** Secure the circuit breaker against unintentional recommissioning.

7.1.3 Work with the removal of chemical containers = replacing components on or behind the carrier plate for Liquiline System CA80COD/TP/TN/SI and CA82HA

1. Select **Mode** → **Manual mode** and confirm by pressing the navigator button.
2. Wait until the analyzer has finished the measurement and **Manual** is displayed as the “Current mode”.
3. Stop the sample feed.
4. Remove the hoses for reagents, the sample and, if necessary, the dilution water from their sampling points. Wipe the ends of the hoses with a clean paper towel.
5. Place the hoses in an empty beaker and select **Menu** → **Operation** → **Maintenance** → **Decommissioning** → **Empty hoses**.



The software evaluates this as the bottles being removed. Therefore, they need to be reinserted at a later time.

6. Place the hoses in a beaker with distilled or treated water and select **Menu** → **Operation** → **Maintenance** → **Decommissioning** → **Rinse with water**. Wait until rinsing is finished.
7. Place the hoses back in an empty beaker and select **Menu** → **Operation** → **Maintenance** → **Decommissioning** → **Empty hoses**.



All the hoses are now flushed, clean and filled with air. It is now possible to work on the analyzer without risk.

8. **Disconnect the analyzer from the power supply!** Secure the circuit breaker against unintentional recommissioning.

7.2 Installing the M12 plug-in connector

When using the M12 plug-in connector, the sensor cable can be connected to the outside of the CA8x. In this case, a CYK10 or CYK11 sensor cable with an M12 connector is required.

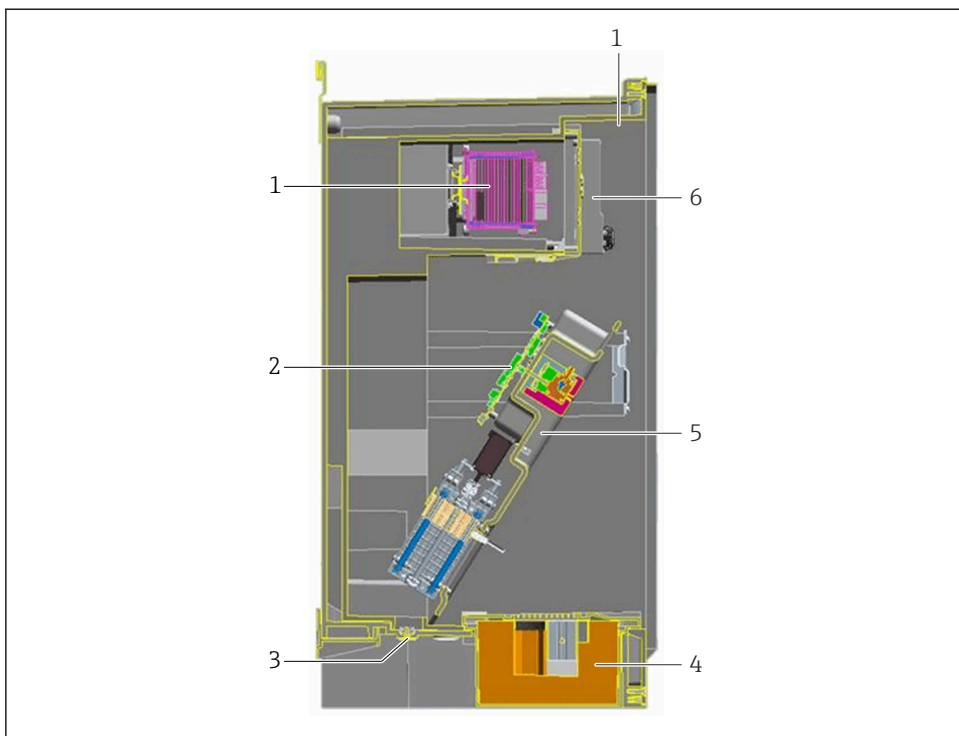

A0058484

📐 20 Cut-away drawing of CA8x

- 1 Electronics compartment with installation frame for slide-in modules
- 2 Control module (without cover)
- 3 Cable entries
- 4 Cooling
- 5 Mounting frame (expanded)
- 6 Operating device with display

1. Carry out the preparatory work according to Section 7.1.2 → 📐 21 or Section 7.1.3 → 📐 22 (depending on the type of analyzer).
2. Remove the bottle tray.
3. Mount the M12 socket (at the bottom of the terminal compartment at the base of the analyzer) instead of the cable gland of the sensor cable.
4. Loosen the screws of the mounting frame and fold out the mounting frame → 📐 20, 📐 23.
5. Loosen the screws of the electronics compartment hatch and fold the hatch forward.

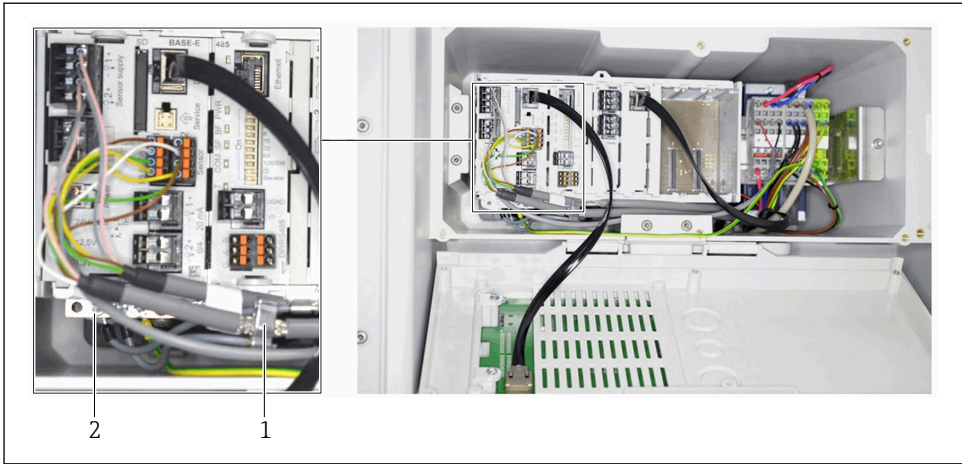

A0058485

21 Electronics compartment with sensor cable connection

6. Guide the cable of the M12 socket up behind the mounting frame to the electronics compartment.
7. Slide the shield connection cable onto the sensor cable up to the stripped point and clamp to the shielding braid using flat pliers (→ 21, 24, position 1).
8. Select the required sensor input on the BASE(2)-E base module.
9. Connect the cable ends, see the table below.

Brown	Terminal 87 (+ 3.15 V)
White	Terminal 88 (GND 3.15 V)
Green	Terminal 97 (data A)
Yellow	Terminal 98 (data B)
Pink	Terminal 85 (+24 V)
Gray	Terminal 86 (GND 24 V)
Shield cable	Grounding bar (2, → 21, 24)

Recommissioning:

1. Insert the bottle tray with reagents, standard and cleaner.
2. Switch the power supply to the analyzer back on.
3. Connect hoses to the reagent containers and fill the hoses as described below:
4. Select **Menu** → **Operation** → **Maintenance** → **Bottle replacement** → **Bottle insertion** → **Bottle selection**.
5. Highlight all the bottles and confirm by pressing the **OK** softkey.

6. Select the **Bottles inserted confirmation** entry.
7. Activate the sample feed.
8. Select **Mode** → **Continue automatic mode** to start the normal measuring operation.

7.3 Replacing the power unit for 100–240 V AC or 24 V DC

⚠ DANGER

Risk of death due to electric shock!

- ▶ Ensure that the terminals for the mains voltage are de-energized!

1. Take the device out of service as per Section 7.1.1 → 📖 21.
2. Loosen the screws of the electronics compartment hatch and fold the hatch forward → 📖 21, 📖 24.
3. Disconnect all the terminals of the power unit (primary and secondary).
 - ↳ The power unit is located on the back behind the terminals → 📖 22, 📖 25.



A0058602

📖 22 Positioning the power unit

4. Release the support brackets (1) of the electronic unit and flip over the electronic plug-in unit. If necessary, remove the connectors from the modules.
5. Unlock the mounting bracket and remove the power unit from the DIN rail.
6. Snap the new power unit onto the DIN rail and reconnect the cables.

- i** Ensure that primary and secondary connections are not accidentally interchanged!



23 Removing the electronic unit

7. First connect the protective earth conductor.

i Pay attention to the secondary polarity (red cable = +24 VDC, blue cable = 0 V).

In the case of a DC power supply, also make sure to ensure the correct polarity on the primary side!

8. Reinstall the control electronics and re-establish all the connections.
9. Close the electronics compartment hatch.

Recommissioning:

1. Switch the power supply to the analyzer back on.
2. Select **Mode** → **Continue automatic mode** to start the normal measuring operation.

7.4 Replacing interface module version 1 or version 2

⚠ WARNING

Risk of material damage!

- ▶ A version 1 interface module must be replaced by a version 1 interface module and a version 2 interface module must be replaced by a version 2 interface module. Otherwise, the interface module is not compatible with the remaining electronics modules.
- ▶ Refer to the compatibility information → 13.

1. Take the device out of service as per Section 7.1.1 → 21.
2. Loosen the screws of the electronics compartment hatch and fold the hatch forward → 21, 24.
3. Remove the RJ45 connector from the interface module.
4. Press the tabs inwards together and pull out the interface module by the tabs.



5. Insert the new interface module.
6. Reinsert the RJ45 connector.
7. Close the electronics compartment hatch.

Recommissioning:

1. Switch the power supply to the analyzer back on.
2. Select **Mode** → **Continue automatic mode** to start the normal measuring operation.

7.5 Replacing the backplane

 The backplane can only be replaced by E+H specialists!

 Once the backplane has been replaced, the device must be reconfigured. The configuration can be saved on an SD card with the assistance of menu guidance. Please use the SD card recommended by E+H (industrial flash memory 1 GB), order option “T4” in the CA8x product structure or accessories order number 71110815. The slot for the SD card (1) is located on the BASE(2)-E module →  24,  28.



To save, open the housing as described in the “Opening the electronics compartment” →  27 section, insert the SD card, close the cover provisionally again and go to **Menu** → **Setup** → **General settings** → **Extended setup** → **Data management** → **Save setup** → **Save**.

WARNING

Risk of material damage!



- ▶ A version 1 backplane must be replaced by a version 1 backplane and a version 2 backplane must be replaced by a version 2 backplane. Otherwise, the backplane is not compatible with the remaining modules.
- ▶ Refer to the compatibility information →  13.

7.5.1 Opening the electronics compartment

1. Take the device out of service as per Section 7.1.1 →  21.
2. Make sure the device is de-energized. It is not permitted to replace a live module!
3. Loosen the screws of the electronics compartment hatch and fold the hatch forward →  21,  24.

7.5.2 Removing the plug-in modules

 All terminal strips and connectors on the modules can be removed. No cables must be disconnected.

1. Remove all terminal strips and connectors from the modules.
2. If available, remove the end cover (3) and all the dummy covers.
3. Press the locking tabs of the modules (2) inwards together and pull out all the modules by the locking tabs →  24,  28.

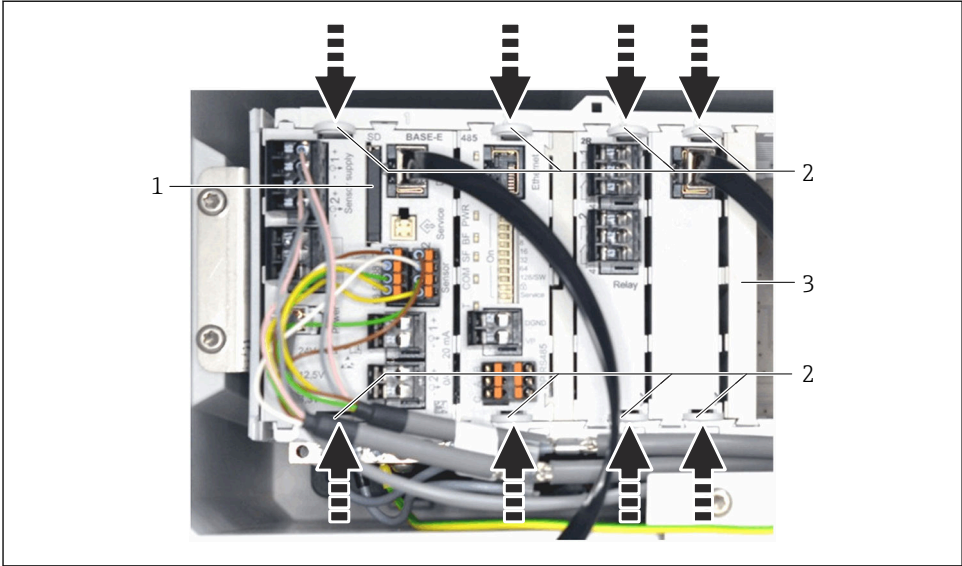



A0058488

24 SD card slot, locking mechanisms

- 1 Slot for SD memory card
- 2 Locking tabs
- 3 End cover

7.5.3 Replacing the backplane

 The backplane (1) is not rotation-proof. For this reason, note the installation position
 →  25,  29!

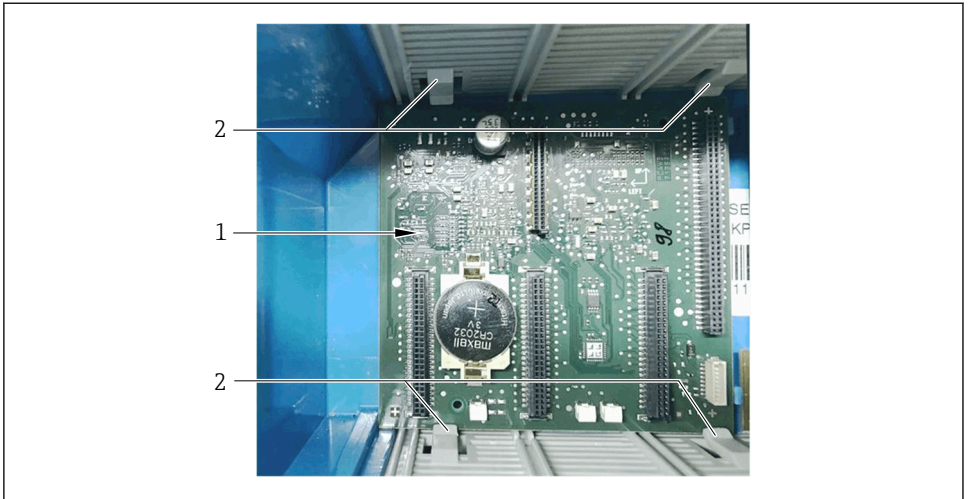

A0058489

📷 25 Backplane module, version 2 as an example

1. Press the four locking mechanisms (2) in the side walls outwards and remove the backplane → 📷 25, 📄 29.
2. Insert the new backplane. It must lock into place in the locking mechanisms (2).
3. Reinstall the modules and covers.
4. Reconnect all of the connectors.
5. Close the electronics compartment hatch.
6. Re-establish the power supply.

7.5.4 Data recovery

Once the device has been restarted, the following data must be re-entered manually → 📷 26, 📄 30:

- Serial number
- Type code (entered in the “Function Codes”, always 037xxx for CA8x)
- Order code
- Extended order code (order code ext.)
- Upgrade codes (function codes)
- Parameter code (for CA8x always 26xxxxx)

i If the device is restarted after replacing the backplane, the required input fields are displayed automatically.

1. Read the requested information from the nameplate → 📷 26, 📄 30 and enter it in the appropriate field.

2. After it has been entered completely and correctly, there is a prompt to restart the device. Press the **OK** button.
3. Enter upgrade codes. The value is entered under **Menu → Setup → General settings → Extended setup → Data management → Upgrade code → Enter upgrade code**. Not all the functionalities of the analyzer are activated without entering the upgrade codes.

i Upgrade codes for extensions installed subsequently, whose codes are not listed on the nameplate, must be found in the past delivery documents.

4. Confirm the codes and perform a device reset so that the upgrade codes are activated.
5. Check the function of the device.
6. If the configuration was saved to an SD card, it can be restored with this backup file (via **Menu → Setup → General settings → Extended setup → Data management → Load setup**). Otherwise, the device must be fully reconfigured by hand.

i Repeated calibration of additionally connected Memosens sensors is not required. The calibration data is saved in the Memosens sensors and are automatically read into the device again.

Endress+Hauser 	
Liquiline System CA80	Made in Germany, 70839 Gerlingen
Order code:	CA80AM-11V0/0
Order code ext.:	CA80AM-AAA11A301AAFBG1N2N3
Ser. No.:	HB000905AN0
Mains:	100...230 V AC 50/60 Hz 1450 VA
Protection class:	IP55
Ambient Temperature.	5 <Ta< +40 °C
Function code	037D12F 0516388 061D7FB 0B1645C 0E17L81 0F05AEB 20029FD 280E2AC 17F0245 2309D8E
1	2

A0058490

26 Nameplate entries

- 1 Type code
- 2 Activation codes

i The type code for analyzers always starts with 037.... It does not necessarily need to be at the first position! For more recent devices, the type code is in bold.

Digits 1 to 3: Indicates the upgrade code







Digits 4 to 7: Customized according to device ser. no.

037 yyyy = type code = family code for CA80

05X yyyy = function code for operating language

06X yyyy = function code for additional Memosens input of BASE2 module
08X yyyy = function code for additional analog output of BASE2 module
0B0 yyyy = function code for deactivating the communication protocols. Do not enter a value if communication is already active (see 0BX yyyy).
0BX yyyy = function code for digital communication
0DX yyyy = function code for E+H or OEM identification
0FX yyyy = function code for cooling module
20X yyyy = function code for sample collector sensor
23X yyyy = function code for measuring range
26X yyyy = function code for CA80 parameters
28X yyyy = function code for configuring channels
2CX yyyy = function code for internal dilution function
2DX yyyy = function code for Heartbeat Technology
32X yyyy = function code for mathematical functions
35X yyyy = function code for web server on BASE2

7.6 Replacing the extension backplane

1. Take the device out of service as per Section 7.1.1 →  21.
2. Opening the electronics compartment →  27.
3. Remove the plug-in modules →  27.
4. Leave the backplane (left module) in the device.
5. Release the connector of the extension backplane →  27,  32.
6. Press the locking mechanisms (2, →  25,  29) in the side walls outwards and replace the extension backplane.

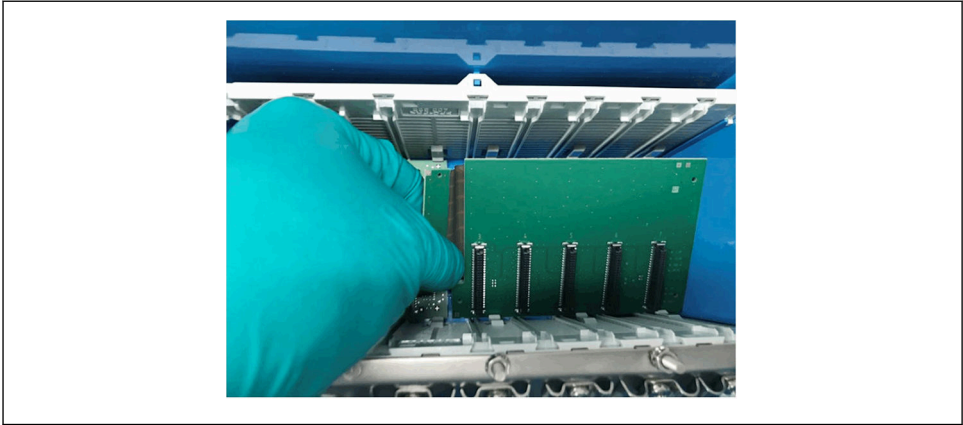

A0058603

27 Extension backplane

i The extension backplane is a passive component and has no effect on device data or settings.

There is only one version of the extension backplane, which can be used with all device versions and device generations.

7. Reinstall plug-in modules and covers.
8. Reconnect all of the connectors.
9. Close the electronics compartment hatch.

Recommissioning:

1. Switch the power supply to the analyzer back on.
2. Select **Mode** → **Continue automatic mode** to start the normal measuring operation.



7.7 Replacing the BASE(2)-E base module

⚠ WARNING

Risk of material damage!

- ▶ A BASE-E base module must be replaced by a BASE-E base module and a BASE2-E base module by a BASE2-E base module. Otherwise, the base module is not compatible with the remaining electronics modules.
- ▶ Refer to the compatibility information → 13.







1. Take the device out of service as per Section 7.1.1 → 21.
2. Loosen the screws of the electronics compartment hatch and fold the hatch forward → 21, 24.
3. Remove all the plug-in connections of the BASE(2)-E base module.

4. Push the tabs inwards together and pull out the BASE(2)-E module by the tabs
→  24,  28.
5. Insert the new base module.
6. Reinsert all of the connectors.
7. Close the electronics compartment hatch.

Recommissioning:

1. Switch the power supply to the analyzer back on.
2. Select **Mode** → **Continue automatic mode** to start the normal measuring operation.



7.8 Replacing the housing fan (fan for electronics compartment)

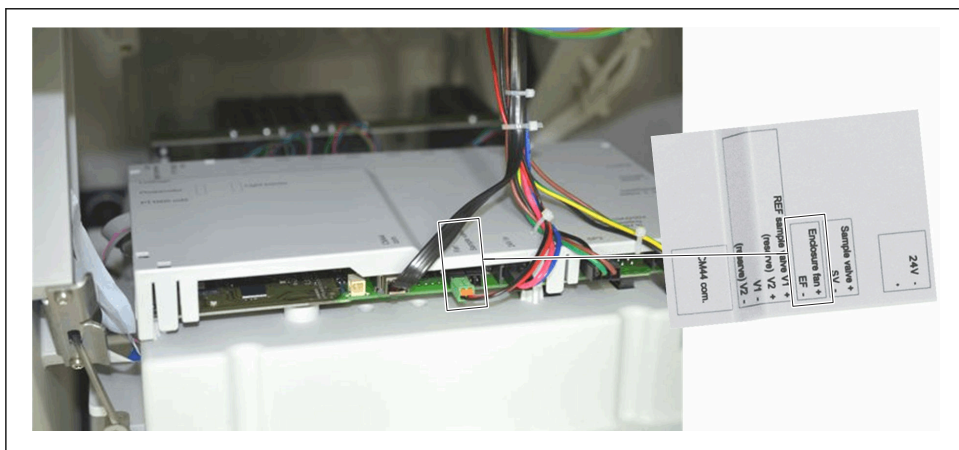



1. Carry out the preparatory work according to Section 7.1.2 →  21 or Section 7.1.3
→  22 (depending on the type of analyzer).
2. Remove the bottle tray.
3. Loosen the screws of the mounting frame and fold out the mounting frame
→  20,  23.
4. Unplug the connector of the housing fan at the control module (“Enclosure fan EF”
connector, →  28,  33).



A0058492

 28 *Electrical connection of the housing fan at the control module.*

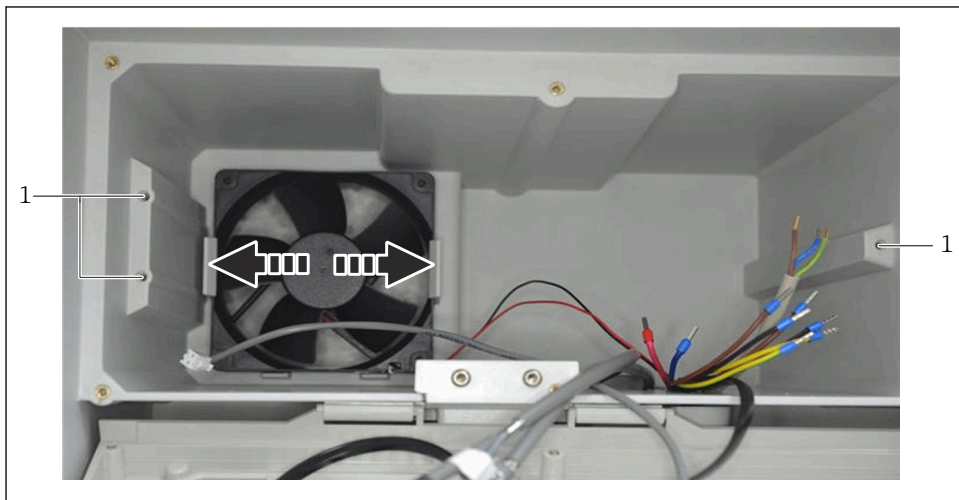

5. Release the cable from the cable harness.
6. Loosen the screws of the electronics compartment hatch and fold the hatch forward
→  21,  24.
7. Release all connectors on the modules of the control electronics.

8. Loosen the three screws on the control electronics bracket (2x left in the housing and 1x right in the housing (→  29,  34, position 1) and pull the control electronics forwards.
9. Bend the retaining tabs of the fan outwards and pull the fan out of its holder
→  29,  34.



A0058491

 29 *Removing the housing fan*

10. **Outdoor version only:** Disconnect the black fan cable from the WAGO terminal **J** or from the coupling relay **KOF-A2** (1)→  30,  35.

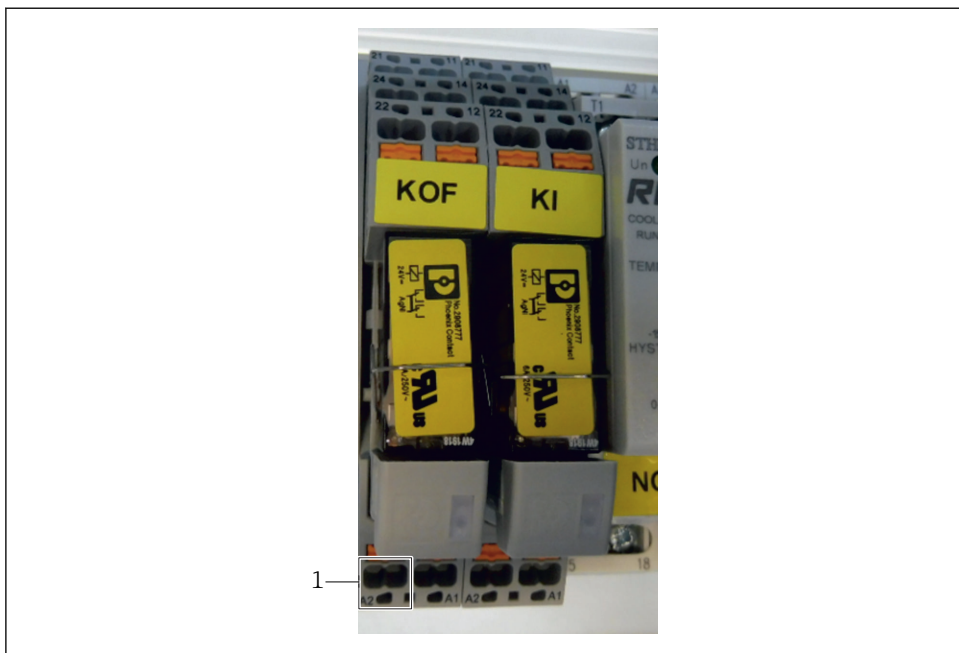

A0061194

30 KOF-A2 coupling relay

11. Push the new housing fan into place until it clicks into place in the two retaining tabs.
12. Plug in the connector of the housing fan on the control module (“Enclosure fan EF” connector on the control module, → 28, 33).
13. Reinstall the control electronics and re-establish all the connections.
14. **For outdoor version only:** Connect the red fan cable to the socket terminal strip. Reconnect the black fan cable to WAGO terminal **J** or to the coupling relay **KOF-A2** .→ 31, 36
15. **Indoor version only:** Connect the black fan cable **and** red fan cable to the socket terminal strip.

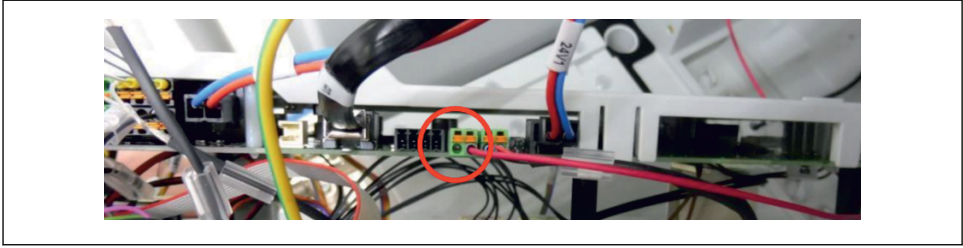

A0061195

 31 Connection of red fan cable (outdoor version)

16. Close the electronics compartment hatch.
17. Fold up the carrier plate and secure the screws.

Recommissioning:

1. Insert the bottle tray with reagents, standard and cleaner.
2. Switch the power supply to the analyzer back on.
3. Connect hoses to the reagent containers and fill the hoses as described below:
4. Select **Menu** → **Operation** → **Maintenance** → **Bottle replacement** → **Bottle insertion** → **Bottle selection**.
5. Highlight all the bottles and confirm by pressing the **OK** softkey.
6. Select the **Bottles inserted confirmation** entry.
7. Activate the sample feed.
8. Select **Mode** → **Continue automatic mode** to start the normal measuring operation.

7.9 Replacing the photometer electronics FSFC1



 The spare parts kit **71389529 Kit CA8x photometer electronics** is identical for all analyzer types; only the work steps for replacing the photometer electronics differ.

The individual work steps are described in the following sections.

7.9.1 CA80SI/82HA

1. Carry out preparatory work as per Section 7.1.3 →  22.
2. Loosen the screws of the carrier plate (6x T25) and fold the carrier plate forward. Keep the screws for reuse.

 Ensure that the capillaries are not damaged.

3. The photometer electronics are located on the bottom left edge of the carrier plate. To release the photometer electronics, remove the screw together with the washer →  32,  37.

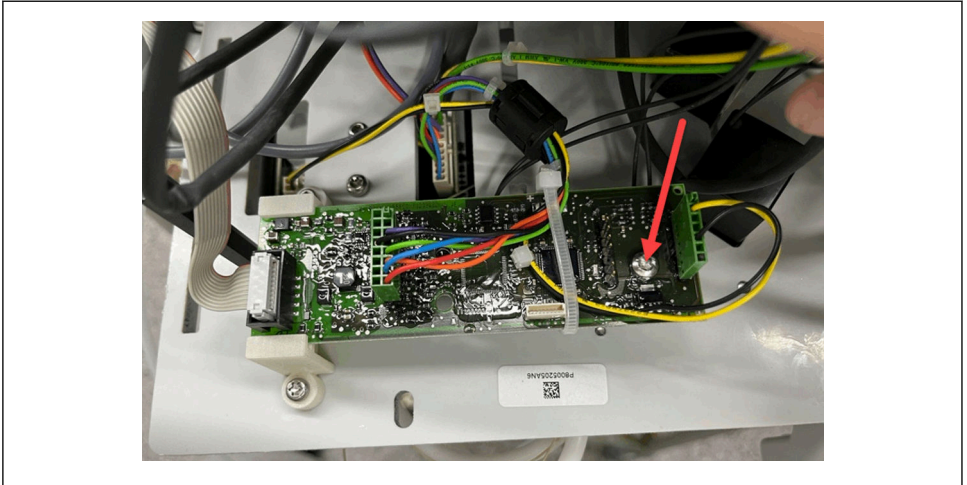

A0061196

32 Releasing the photometer electronics

4. Remove all three connectors from the photometer electronics FSFC1 (see → 33, 37).

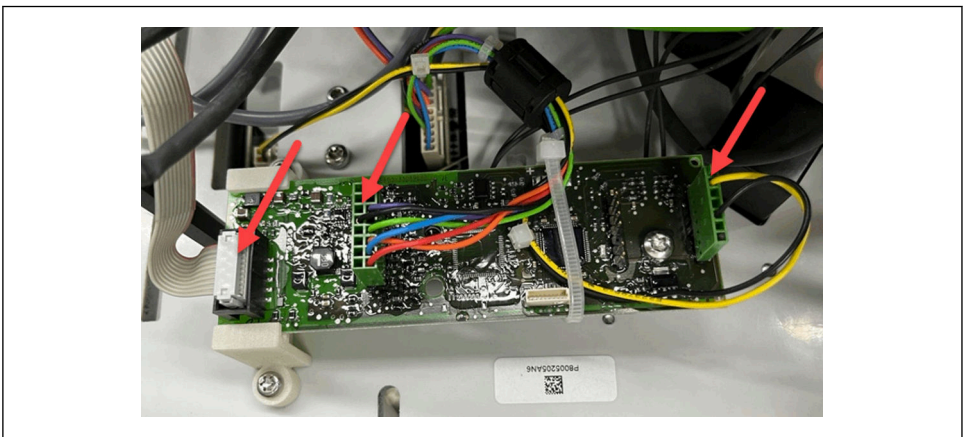

A0061197

33 Removing the connectors

5. Slowly pull the photometer electronics out of the holder in the direction of the arrow → 34, 38.

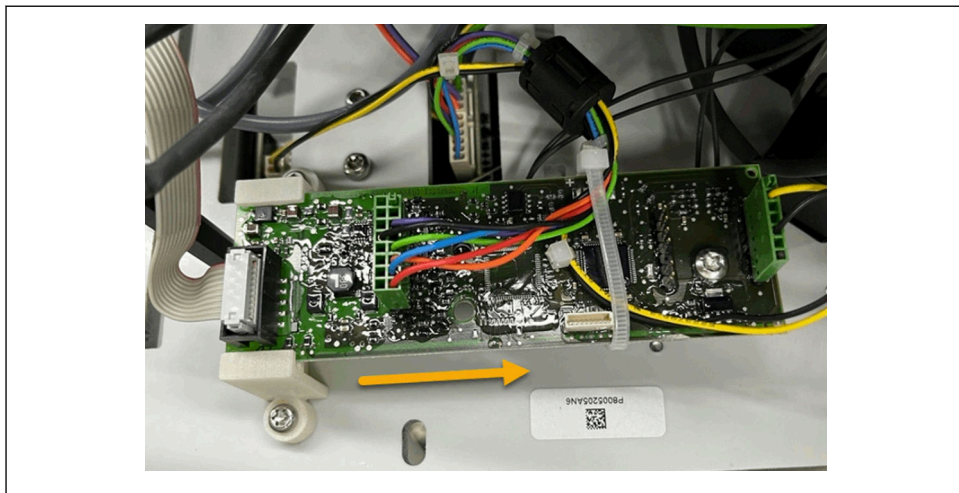

A0061198







34 Removing the photometer electronics

6. Secure the new photometer electronics to the reactor. New screws and washers are included in the scope of delivery of the kit.
7. Reconnect the three connectors. Refer to → 35, 40 for alignment. All three connectors are coded so that they cannot be mixed up.
8. Fold the carrier plate back and secure it again (6x T25).

Recommissioning:

1. Insert the bottle tray with reagents, standard and cleaner.
2. Switch the power supply to the analyzer back on.
3. Connect hoses to the reagent containers and fill as described below:
4. Select **Menu → Operation → Maintenance → Bottle replacement → Bottle insertion → Bottle selection**.
5. Highlight all the bottles and confirm by pressing the **OK** softkey.
6. Select the **Bottles inserted confirmation** entry.
7. Activate the sample feed.
8. Select **Mode → Continue automatic mode** to start the normal measuring operation.
9. It is recommended to perform one single-point calibration at the end of the service work. To do so, select **Menu → Calibration → Analyzer → Determine calibration factor**.
10. Check all the new components for leaks.

7.9.2 CA8x individual and sum parameters

1. Carry out preparatory work as per Section 7.1.3 →  22.
2. Loosen the screws of the carrier plate (6x T25) and fold the carrier plate forward. Keep the screws for reuse.
3. Remove all four connectors from the photometer electronics FSFC1 (see →  35,  40).
4. The photometer electronics are screwed onto the reactor from behind with 3 Torx screws M3 (see →  35,  40). Remove these screws together with the washers.
5. Remove the old photometer electronics.
6. Secure the new photometer electronics to the reactor. New screws and washers are included in the scope of delivery of the kit.
7. Reinsert the four connectors. Refer to →  35,  40. All four connectors are coded so that they cannot be mixed up.
8. Fold the carrier plate back and secure it again (6x T25).

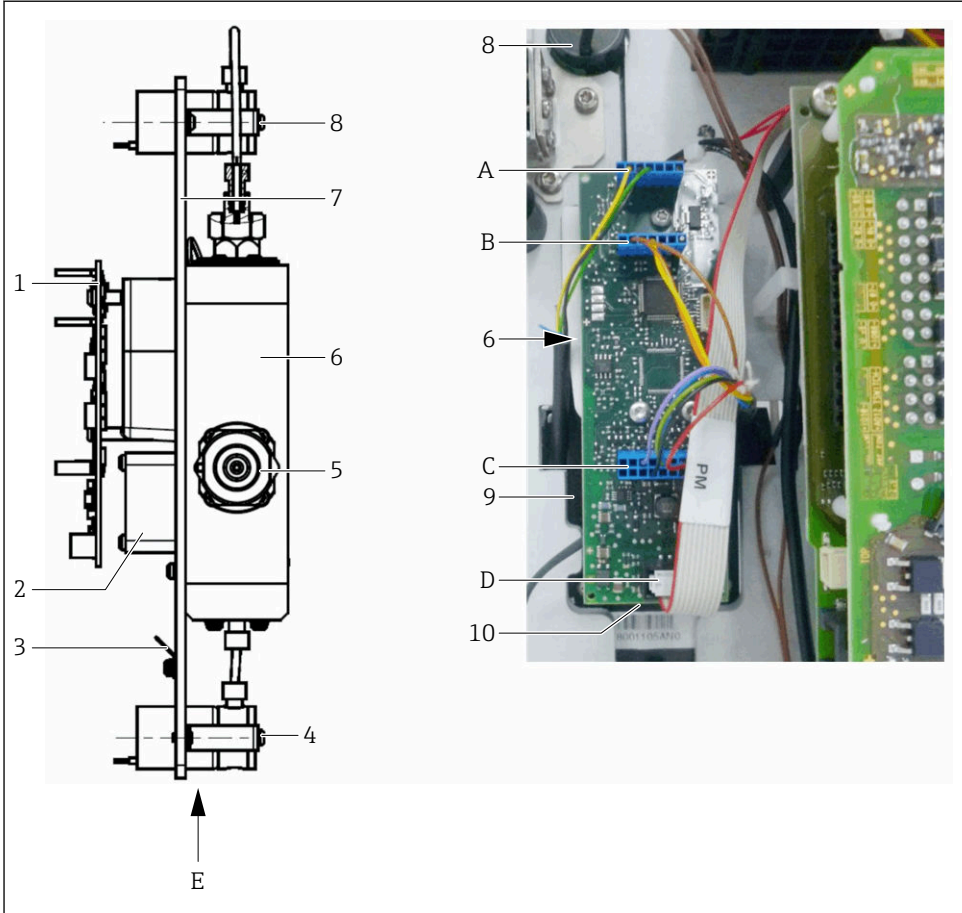

A0058821

35 Photometer electronics FSFC1

- A Connector for receiver module: 7-pin connector, coding = pin 1
 B Connector for transmitter module: 7-pin connector, coding = pin 5
 C Connector for transmitter module: 16-pin connector, coding = pin 15
 D Connection of photometer ↔ control module: 10-pin connector and FBL "PM"
 E Schematic view of photometer: photometer electronics fitted on reactor (electronics holder not shown)

- 1 FSFC1 module
 2 Reactor fan
 3 Grounding
 4 Lower reactor valve (RVL)
 5 Transmitter module
 6 Pressure reactor
 7 Reactor carrier plate
 8 Upper reactor valve ventilation (RVU)
 9 Electronics holder
 10 Photometer electronics FSFC1

Recommissioning:

1. Re-establish the power supply to the device.
2. Insert the bottle tray together with all bottles.
3. Screw the cover with the hoses onto the bottles. Ensure that the hoses are not mixed up! If in doubt, refer to the hose connection diagram on the inside of the device door.
4. Select **Menu** → **Operation** → **Maintenance** → **Bottle replacement**.

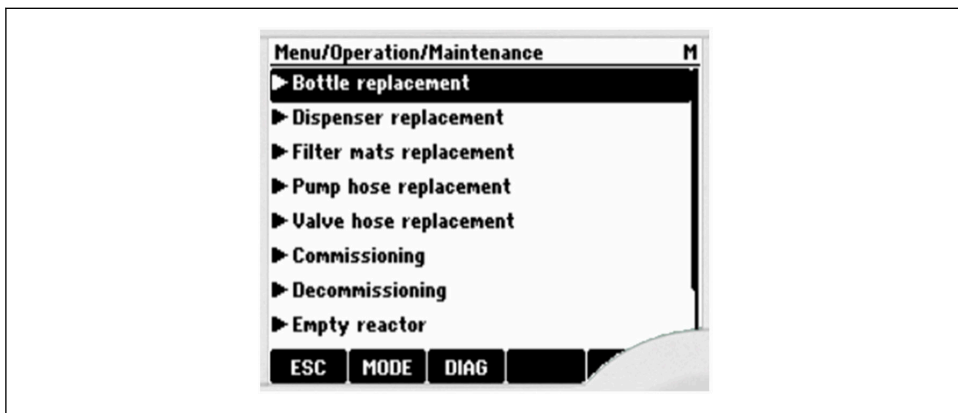

A0058825

5. Select the **Bottle insertion** entry, then the **Bottle selection** entry.
6. Activate all bottles and confirm by pressing **OK**. Confirm the **Bottle insertion** entry by pressing **OK**.
7. Press the **Bottles inserted confirmation** entry to confirm that all bottles have been inserted.

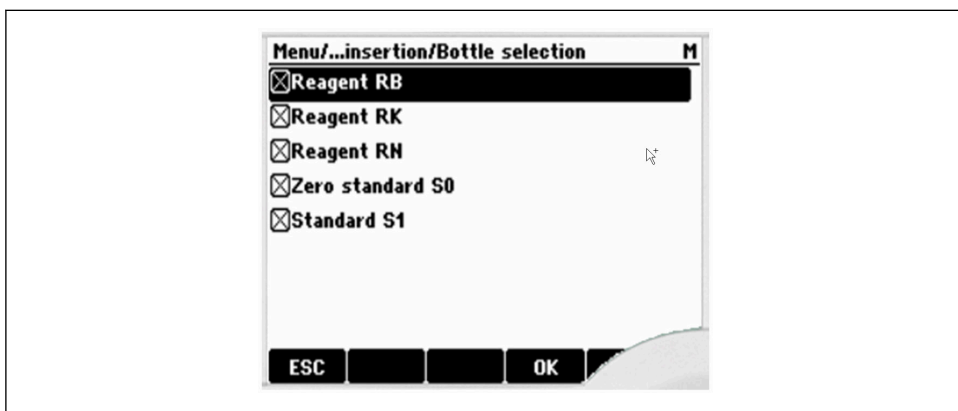

A0058826

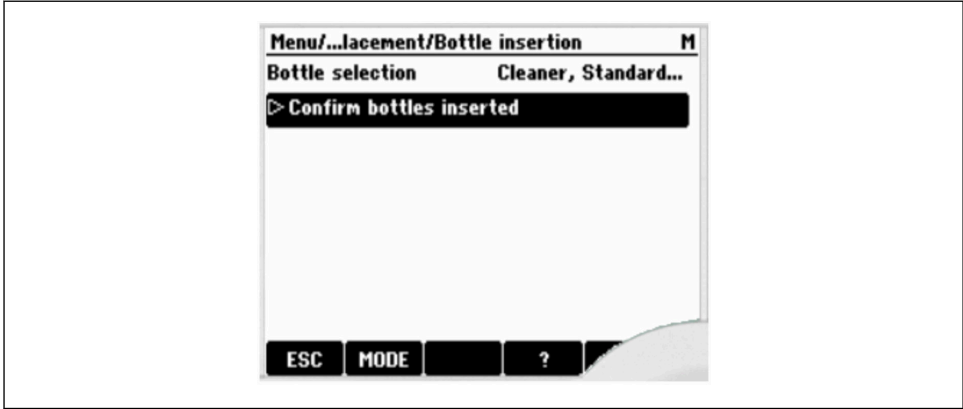

A0058827

8. Check the status of the bottles in the **Bottle status** menu. The status of all bottles must be "inserted". The analyzer will not start a measurement or calibration if any bottles are marked as "removed".

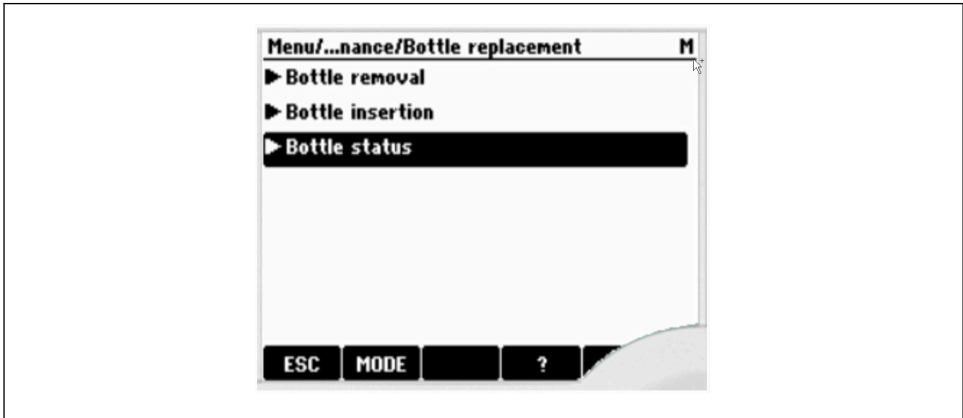

A0058829

9. Select **Menu** → **Operation** → **Maintenance** → **Commissioning**. Confirm the **Start commissioning** entry.

8 Additional documentation

Detailed information on the devices can be found in the Operating Instructions for the analyzer and in the other documentation, available at:

- www.endress.com/device-viewer
- Smartphone/tablet: Endress+Hauser Operations app

9 Disposal



If required by the Directive 2012/19/EU on waste electrical and electronic equipment (WEEE), the product is marked with the depicted symbol in order to minimize the disposal of WEEE as unsorted municipal waste. Do not dispose of products bearing this marking as unsorted municipal waste. Instead, return them to the manufacturer for disposal under the applicable conditions.



71755820

www.addresses.endress.com
