

Brief Operating Instructions

FlexView FMA90

Control unit with color display and touch control for up to 2 ultrasonic, radar, hydrostatic or universal 4-20 mA/HART® level sensors



These Brief Operating Instructions are not a substitute for the Operating Instructions. For further information on the product, see:

- www.endress.com/deviceviewer
- Smartphone/tablet: Endress+Hauser Operations app



Table of contents

1	About this document	3
1.1	Symbols	3
2	Basic safety instructions	4
2.1	Requirements for the personnel	4
2.2	Intended use	4
2.3	Workplace safety	5
2.4	Operational safety	5
2.5	Product safety	5
3	Incoming acceptance and product identification	5
3.1	Incoming acceptance	5
3.2	Product identification	6
3.3	Storage and transport	6
4	Mounting	7
4.1	Mounting requirements	7
4.2	Mounting the polycarbonate field housing	7
4.3	Installing a DIN rail device	8
4.4	Mounting in a panel	10
4.5	Post-mounting check	11
5	Electrical connection	12
5.1	Connecting requirements	12
5.2	Connecting the device	13
5.3	Special connection instructions	24
5.4	Hardware settings	27
5.5	Ensuring the degree of protection	28
5.6	Post-connection check	29
6	Operation options	30
6.1	Structure and function of the operating menu	30
6.2	Access to the operating menu via the local display	32
6.3	Access to operating menu via web browser	36
7	System integration	36
7.1	Integrating the measuring instrument into the system	36
8	Commissioning	36
8.1	Post-installation check	36
8.2	Switching on the device	36
8.3	Configuring the operating language at the device	37
8.4	Configuring the device	37
9	Maintenance	41
9.1	Cleaning	41

1 About this document

1.1 Symbols

1.1.1 Safety symbols

DANGER

This symbol alerts you to a dangerous situation. Failure to avoid this situation will result in serious or fatal injury.

WARNING

This symbol alerts you to a potentially dangerous situation. Failure to avoid this situation can result in serious or fatal injury.











CAUTION

This symbol alerts you to a potentially dangerous situation. Failure to avoid this situation can result in minor or medium injury.





NOTICE

This symbol alerts you to a potentially harmful situation. Failure to avoid this situation can result in damage to the product or something in its vicinity.

1.1.2 Symbols for certain types of information

Symbol	Meaning	Symbol	Meaning
	Permitted Procedures, processes or actions that are permitted.		Preferred Procedures, processes or actions that are preferred.
	Forbidden Procedures, processes or actions that are forbidden.		Tip Indicates additional information.
	Reference to documentation		Reference to page
	Reference to graphic		Series of steps
	Result of a step		Visual inspection



1.1.3 Electrical symbols

	Direct current		Alternating current		Direct and alternating current
	Ground connection		Protective earth (PE)		

1.1.4 Symbols in graphics

1, 2, 3,...	Item numbers	A, B, C, ...	Views
-------------	--------------	--------------	-------

1.1.5 Symbols on the device

	Warning Observe the safety instructions contained in the associated Operating Instructions
	Device protected all over by DOUBLE INSULATION or REINFORCED INSULATION

2 Basic safety instructions

2.1 Requirements for the personnel

The personnel must fulfill the following requirements for its tasks:

- ▶ Trained, qualified specialists must have a relevant qualification for this specific function and task.
- ▶ Are authorized by the plant owner/operator.
- ▶ Are familiar with federal/national regulations.
- ▶ Before starting work, read and understand the instructions in the manual and supplementary documentation as well as the certificates (depending on the application).
- ▶ Follow instructions and comply with basic conditions.

2.2 Intended use

The device is designed for the water and wastewater industry for the evaluation of measured values and device status, as well as for the configuration of the following Endress+Hauser sensors:

- Radar time-of-flight method: Micropilot FMR10B ¹⁾, FMR20B, FMR30B
- Ultrasonic time-of-flight method: Prosonic FMU20B; FMU30B
- Hydrostatic level measurement: Waterpilot FMX11 ¹⁾, FMX21

Universal level sensors can also be connected to the 4 to 20 mA/HART inputs.

Typical measuring tasks

- Level measurement and linearization
- Flow measurement at open flumes and weirs
- Pump control
- Rake control

1) 4 to 20 mA only, configuration via HART not possible

2.2.1 Product liability

The manufacturer does not accept any responsibility for damage that results from non-designated use and from failure to comply with the instructions in this manual.

2.3 Workplace safety

For work on and with the device:

- ▶ Wear the required personal protective equipment according to federal/national regulations.

2.4 Operational safety

Risk of injury!

- ▶ Operate the device only if it is in proper technical condition, free from errors and faults.
- ▶ The operator is responsible for interference-free operation of the device.

Hazardous area

To eliminate danger to persons or the facility when the device is used in the hazardous area (e.g. explosion protection):

- ▶ Check the nameplate to verify if the device ordered can be put to its intended use in the hazardous area.
- ▶ Observe the specifications in the separate supplementary documentation that is an integral part of these instructions.

2.5 Product safety

This product is designed in accordance with good engineering practice to meet state-of-the-art safety requirements and has been tested and left the factory in a condition in which it is safe to operate.

3 Incoming acceptance and product identification

3.1 Incoming acceptance

On receipt of the delivery:

1. Check the packaging for damage.
 - ↳ Report all damage immediately to the manufacturer.
Do not install damaged components.
2. Check the scope of delivery using the delivery note.
3. Compare the data on the nameplate with the order specifications on the delivery note.
4. Check the technical documentation and all other necessary documents, e.g. certificates, to ensure they are complete.



If one of the conditions is not satisfied, contact the manufacturer.

3.2 Product identification

The device can be identified in the following ways:

- Nameplate specifications
- Extended order code with breakdown of the device features on the delivery note

3.2.1 Nameplate

Do you have the correct device?

The nameplate provides you with the following information on the device:

- Manufacturer identification, device designation
- Order code
- Extended order code
- Serial number
- Tag name (TAG) (optional)
- Technical values such as supply voltage, current consumption, ambient temperature, communication-specific data (optional)
- Degree of protection
- Approvals with symbols
- Reference to Safety Instructions (XA) (optional)

- ▶ Compare the information on the nameplate with the order.

3.2.2 Name and address of manufacturer

Name of manufacturer:	Endress+Hauser Wetzer GmbH + Co. KG
Address of manufacturer:	Obere Wank 1, D-87484 Nesselwang
Model/type reference:	FMA90

3.3 Storage and transport

Storage temperature: -40 to $+80$ °C (-40 to $+176$ °F)

Maximum relative humidity: $< 95\%$



Pack the device for storage and transportation in such a way that it is reliably protected against impact and external influences. The original packaging provides the best protection.

Avoid the following environmental influences during storage:

- Direct sunlight
- Proximity to hot objects
- Mechanical vibration
- Aggressive media

4 Mounting

4.1 Mounting requirements

NOTICE

- ▶ When using in hazardous areas, the limit values of the certificates and approvals must be observed.

4.1.1 Ambient conditions

Ambient temperature range:	-40 to +60 °C (-40 to +140 °F) (Type tested) ¹⁾ -35 to +60 °C (-31 to +140 °F) (approved by CSA) ¹⁾	Storage temperature:	-40 to +80 °C (-40 to +176 °F)
Degree of protection:	DIN rail: IP20 Panel: IP65/NEMA Type 4 (Front) IP20 (Rear) Field housing: IP65/NEMA Type 4x	Overvoltage category:	II
Altitude:	Non-ex version: ≤ 3 000 m (9 842 ft) Ex version: ≤ 2 000 m (6 562 ft)	Humidity:	5 to 95 % Non-condensing in the case of panel-mounted and DIN rail device.
Pollution degree:	2	Protection class:	230 V _{AC} Version: II 24 V _{DC} Version: III

1) The functionality of the LCD display becomes limited at $T_A < -20\text{ °C}$ (-4 °F).

4.1.2 Dimensions



For device dimensions, see the 'Technical data' in the Operating Instructions.

4.2 Mounting the polycarbonate field housing

4.2.1 Mounting requirements

Mounting location

- Protected from direct sunlight. Use a weather protection cover if necessary.
- If mounting outdoors: use a surge arrester.
- Minimum clearance to the left: 55 mm (2.17 in); the housing cover cannot be opened otherwise.
- Orientation: vertical

4.2.2 Mounting the device

Wall mounting

The polycarbonate field housing is mounted directly on the wall using 3 screws (ϕ 5 mm (0.20 in), L: min. 50 mm (1.97 in); suitable wall plugs are recommended; not included in the scope of delivery).

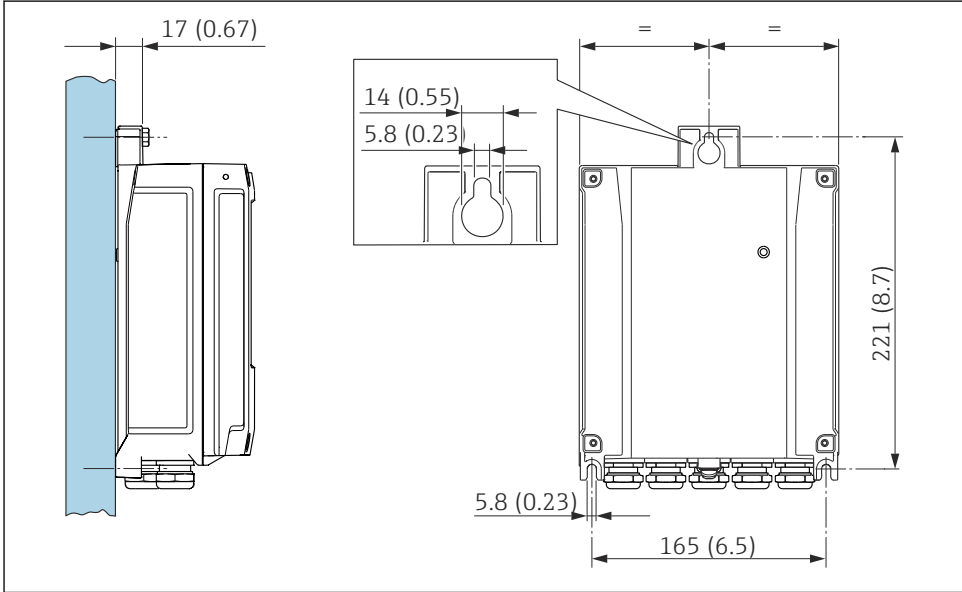

A0051673

1 Wall-mounted polycarbonate field housing. Unit of measurement mm (in)

4.3 Installing a DIN rail device



The DIN rail device is available with or without a display unit (optional). The installation is the same.

4.3.1 Mounting requirements

Dimensions

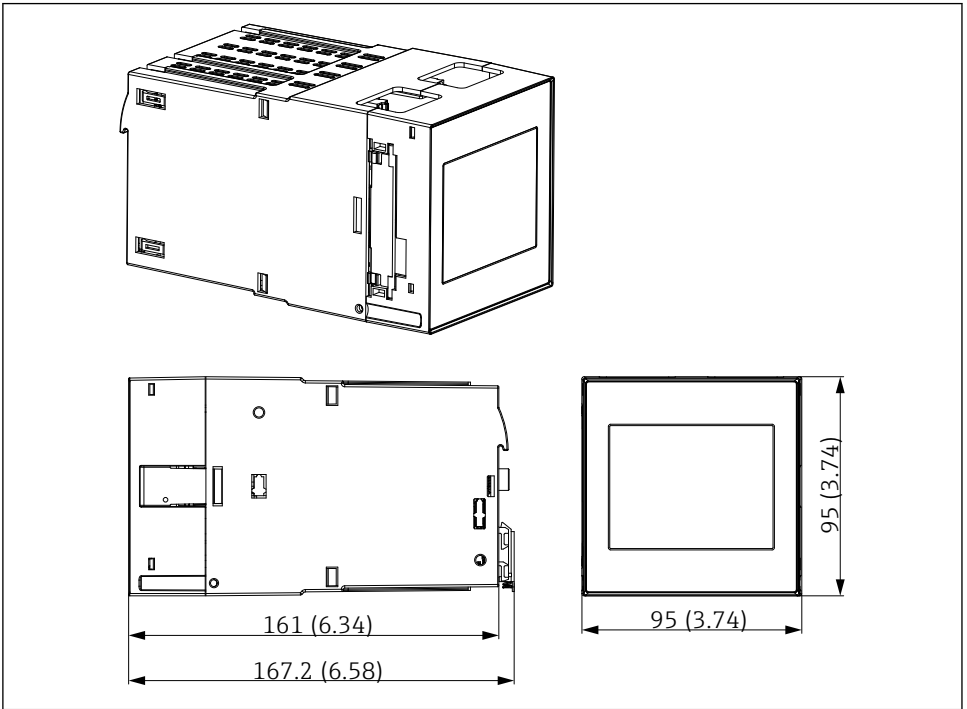

A0051669

 2 Dimensions of the DIN rail device. Unit of measurement mm (in)

Mounting location

- In the cabinet outside hazardous areas
- At a sufficient distance from high-voltage electric cables, motor cables, contactors or frequency converters
- Minimum distance to the left: 20 mm (0.8 in)
To protect against overheating, keep the vents at the top and bottom free
- Orientation: vertical

4.3.2 Mounting the device

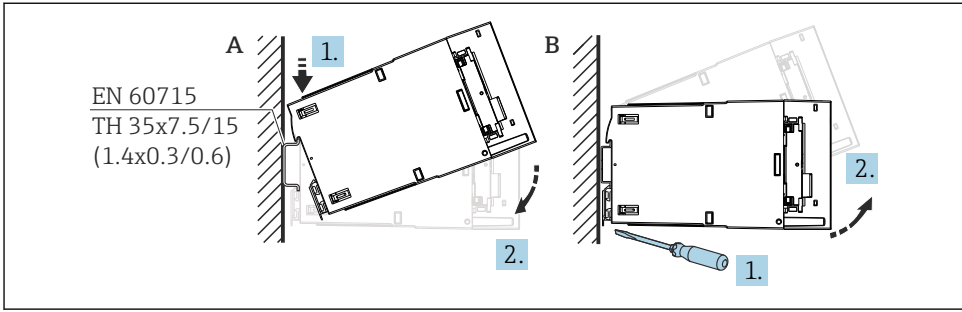

3 Mounting/disassembling the DIN rail housing. Unit of measurement mm (in)

A Mounting

B Disassembly (use a suitable tool to release the locking device at the bottom)

4.4 Mounting in a panel

4.4.1 Mounting requirements

Ensure compliance with the permitted ambient conditions during installation and operation. The device must be protected from exposure to heat.

Installation dimensions

Required panel cutout 92 mm (3.62 in) x 92 mm (3.62 in). Installation depth of 160 mm (6.3 in) for device and cable.

Mounting location

For installation in a panel. The mounting location must be free from vibrations. A suitable electrical, fire-proof and mechanical enclosure must be provided.

Orientation

- Vertical
- Lateral clearance (arranged side-by-side) min. 10 mm (0.4 in)



When connecting Ethernet cables, observe the clearance below.

4.4.2 Mounting the device

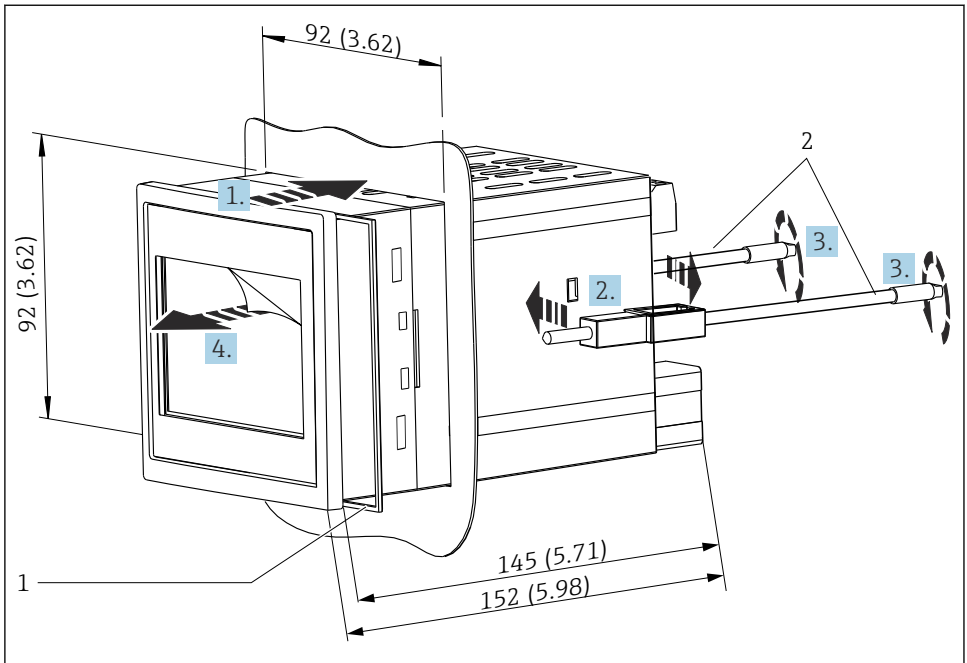

A0050162

 4 Installation in a panel. Unit of measurement mm (in)

Mounting the device in a panel

1. Push the device with the sealing ring (item 1) through the panel cutout from the front.
2. Hold the device horizontally and clip the fastening clips (item 2) into the openings provided on both sides.
3. Tighten the screws of the fastening clips uniformly using a screwdriver (fastening torque: 0.2 Nm).
4. Remove the protective film of the touch screen.

4.5 Post-mounting check

Device condition and specifications	Notes
Is the device undamaged (visual inspection)?	-
Do the ambient conditions match the device specification (e.g. ambient temperature, measuring range etc.)?	See 'Technical data'
If provided: are the measuring point number and labeling correct?	-

Device condition and specifications	Notes
Is the device mounted correctly? (Visual inspection)	-
Is the device adequately protected against precipitation and direct sunlight?	See Accessories

5 Electrical connection

5.1 Connecting requirements

⚠ CAUTION

Destruction of parts of the electronics

- ▶ Switch off power supply before installing or connecting the device.

 For the 85 to 253 V_{AC} version (mains connection), a switch marked as a circuit breaker, as well as an overload protection device (rated power ≤ 10 A) must be fitted in the supply line near the device (easy to reach).

 For the 10.5 to 32 V_{DC} version: The device must only be powered by a power unit that operates using an energy-limited electric circuit according to UL/EN/IEC 61010-1, Section 9.4 and the requirements in Table 18.

Apart from the relay and the AC supply voltage, only energy-limited circuits according to IEC/EN 61010-1 shall be connected.

5.1.1 Important connection data

Supply voltage	AC version: 85 to 253 V _{AC} (50/60 Hz) DC version: 10.5 to 32 V _{DC}
Power consumption	230 V _{AC} : max. 20 VA 24 V _{DC} : max. 15 VA

 For detailed technical data, see the Operating Instructions

5.1.2 Cable specification

⚠ CAUTION

Unsuitable connection cables may cause overheating and fire hazards, insulation damage, electric shock, power loss, and reduced operating life.

- ▶ Only use connection cables that comply with the specifications below.

 Minimum requirement: Cable temperature range ≥ ambient temperature +20 K

For all connections on the field device and for power and relay connections in the case of the panel-mounted and DIN rail device:

- **Conductor cross-section:** 0.2 to 2.5 mm² (26 to 14 AWG)
- **Cross-section with wire end ferrule:** 0.25 to 2.5 mm² (24 to 14 AWG)
- **Stripping length:** 10 mm (0.39 in)

For digital input, open collector and analog input/output connections in the case of panel-mounted and DIN rail device:

- **Conductor cross-section:** 0.2 to 1.5 mm² (26 to 16 AWG)
- **Cross-section with wire end ferrule (excluding collar/including collar):**
0.25 to 1 mm² (24 to 16 AWG)/ 0.25 to 0.75 mm² (24 to 16 AWG)
- **Stripping length:** 10 mm (0.39 in)

5.1.3 Terminals

The device is fitted with push-in terminals. Rigid conductors or flexible conductors with ferrules can be inserted directly into the terminal without using the lever, and create a contact automatically.

5.2 Connecting the device

5.2.1 DIN rail device

Access to terminals

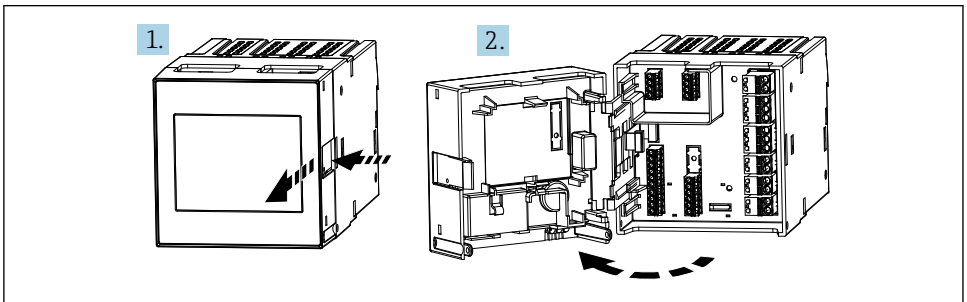

A0051654

5.2.2 Panel-mounted device

Access to terminals

The terminals are freely accessible at the rear of the device.

5.2.3 Terminal compartment of polycarbonate field housing

Access to terminal compartment

Required tool: Torx T8 or flat-blade screwdriver

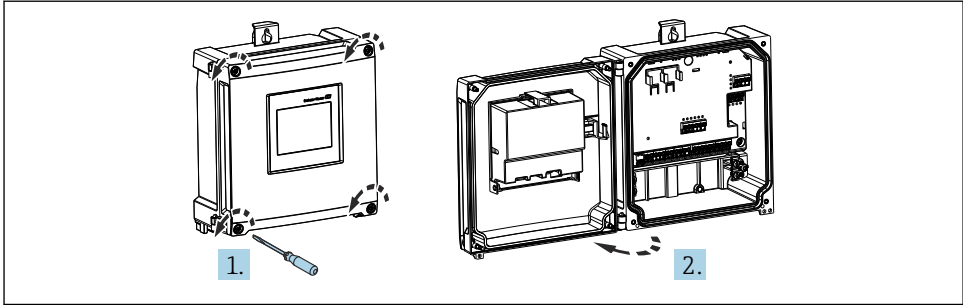

A0053259

- ☒ 5 Access to terminal compartment in polycarbonate field housing

Cable entries of polycarbonate field housing

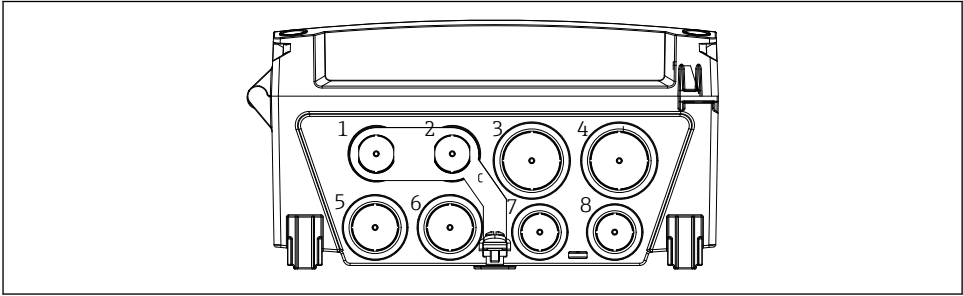

A0061447

- ☒ 6 Precut openings on the bottom of the housing for the following cable entries (example):

- 1 M16x1.5 for Ethernet 2 when using M12 connection or digital I/O
- 2 M16x1.5 for Ethernet 1 when using M12 connection or digital I/O
- 3 M25x1.5 for Ethernet 2 when using a patch cable, digital I/O, or analog I/O
- 4 M25x1.5 for Ethernet 1 when using a patch cable, digital I/O, or analog I/O
- 5 M20x1.5 for power supply
- 6 M20x1.5 for digital I/O
- 7 M16x1.5 for analog I/O
- 8 M16x1.5 for analog I/O

Use a suitable tool to cut out the required openings.

5.2.4 Terminal compartment of aluminum field housing

Access to terminal compartment

Required tool: Torx T8 or flat-blade screwdriver

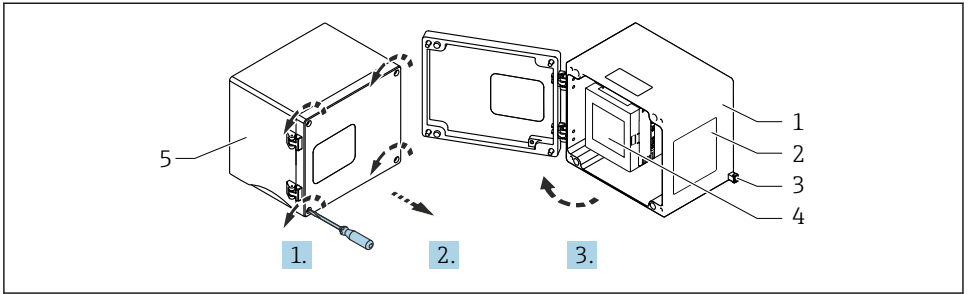

A0053240

7 Access to terminal compartment in aluminum field housing

- 1 Aluminum field housing, open
- 2 Nameplate
- 3 Terminal for protective ground
- 4 FMA90 DIN rail device
- 5 Aluminum field housing, closed

Cable entries for aluminum field housing

- There are eight M20x1.5 openings with dummy covers for cable entries on the bottom of the field housing.
- For the electrical connection, remove the dummy covers and replace them with cable glands. Guide the cables through the cable glands and into the housing. The device is then connected in the same way as the DIN rail device.
- Ethernet cable connection: Insert the cable without the plug and then mount the plug inside.

5.2.5 Terminal areas of DIN rail device

Device version

Order code 040 (housing); option A (DIN rail mounting)

i The DIN rail device is designed for installation in the optional aluminum field housing.

i The DIN rail device is available with or without a display unit (optional). The electrical connection is the same.

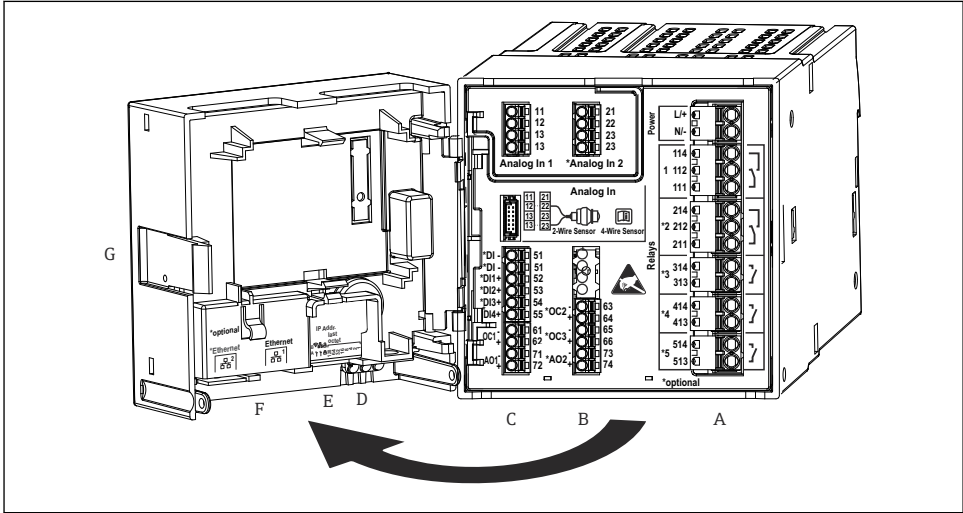

A0049209

8 Terminals for DIN rail device; terminal design: attachable push-in terminals

- A Power unit with relay 1 (changeover contact). Optional: Relay 2 to 5
- B I/O option card with analog input 2 (incl. loop power supply), analog output 2, open collector 2, 3
- C Standard I/O card with analog input 1 (incl. loop power supply), analog output 1, open collector 1, optional: digital inputs 1 to 4
- D 3 LEDs (only for version without display): DS (device status), NS (network status), WLAN
- E DIP switch
- F Ethernet connection 1 (standard), Ethernet connection 2 (optional)
- G Unlocking device

i The switching positions of the relays shown on the terminal area refer to the de-energized (current-free) state.

5.2.6 Terminal areas of panel-mounted device

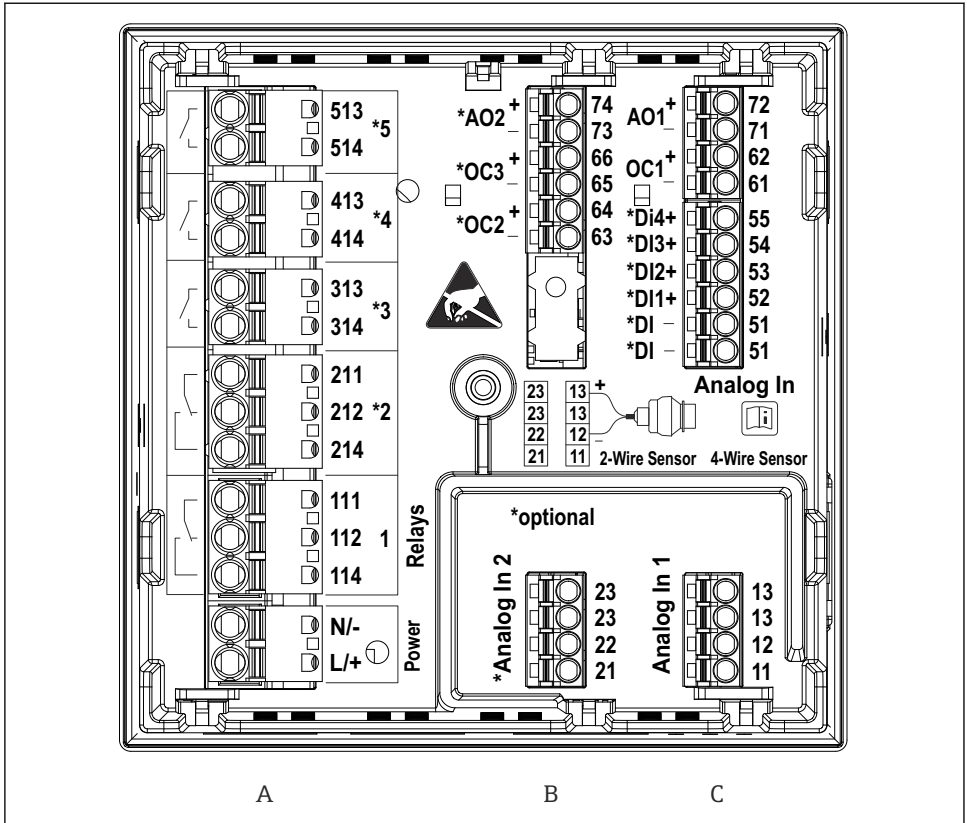

A0049208

9 Terminals for panel-mounted device (rear of device); terminal design: attachable push-in terminals

- A Power unit with relay 1 (changeover contact). Optional: Relay 2 to 5
- B I/O option card with analog input 2 (incl. loop power supply), analog output 2, open collector 2, 3
- C Standard I/O card with analog input 1 (incl. loop power supply), analog output 1, open collector 1, optional: digital inputs 1 to 4

i The switching positions of the relays shown on the terminal area refer to the de-energized (current-free) state.

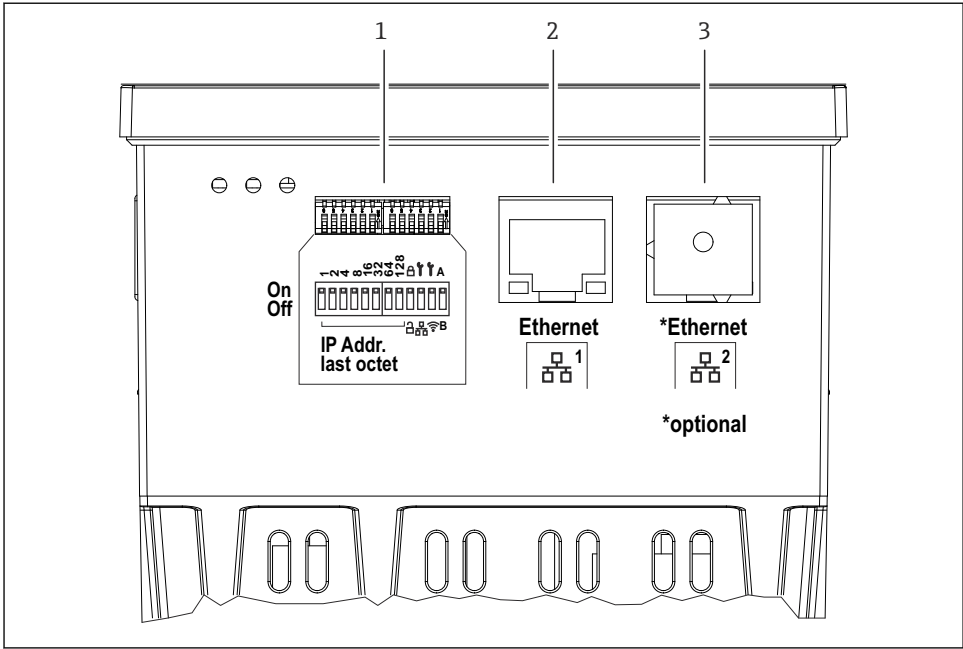

A0053119

10 Connections for panel-mounted device (underside of devices)

- 1 DIP switch
- 2 Ethernet connection 1 (standard)
- 3 Ethernet connection 2 (optional)

5.2.7 Terminal areas of polycarbonate field housing

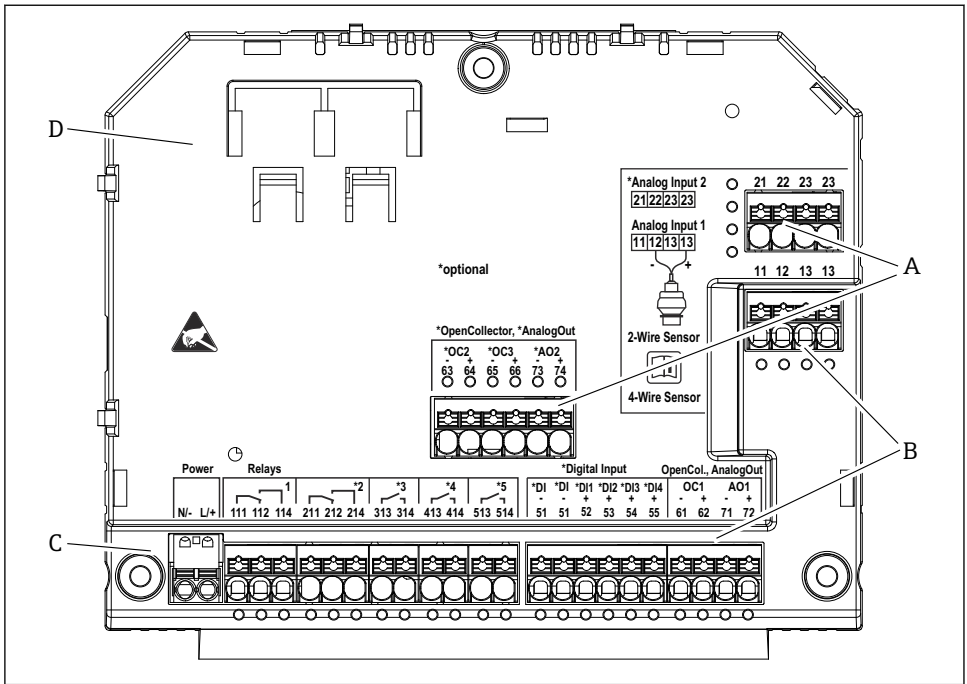

A0050062

11 Terminals in terminal compartment of polycarbonate field housing; terminal design: push-in terminals

- A Terminal area for analog input 2 (incl. loop power supply), analog output 2, open collector 2, 3
- B Terminal area for analog input 1 (incl. loop power supply), analog output 1, open collector 1, optional: Digital inputs 1 to 4
- C Terminal area for power supply and relay 1 (changeover contact). Optional: Relay 2 to 5
- D Holder for commercially available shunting clamps



The switching positions of the relays shown on the terminal area refer to the de-energized (current-free) state.

Terminal areas on rear side of display for the polycarbonate field housing

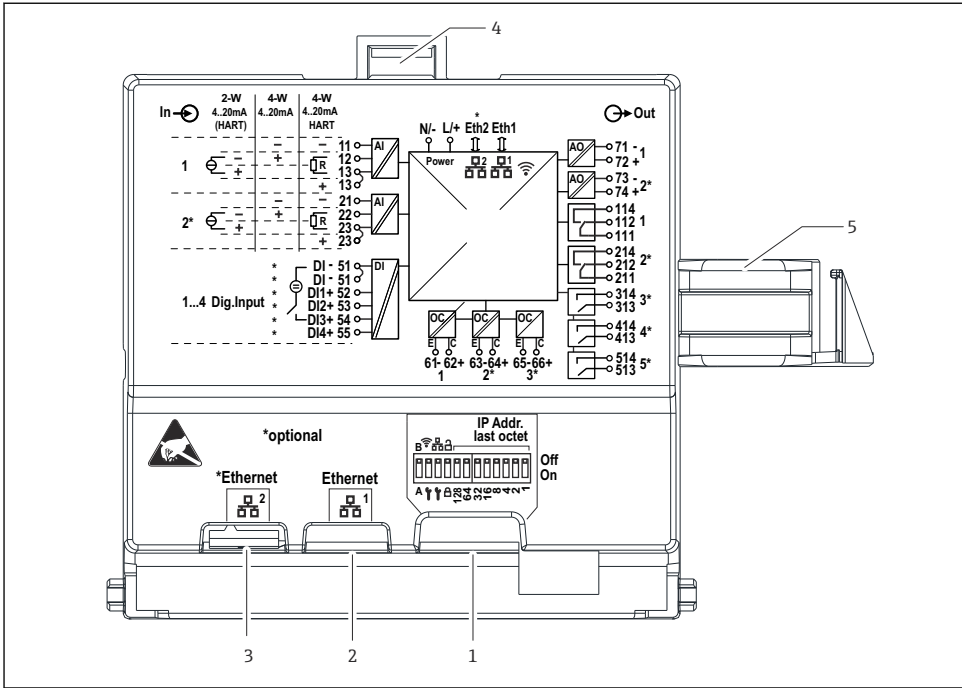

A0052157

12 Connections on the rear side of display for the polycarbonate field housing

- 1 DIP switch
- 2 Ethernet connection 1 (standard)
- 3 Ethernet connection 2 (optional)
- 4 Locking device
- 5 Connecting cable to the main board

i Adapters for RJ45 to M12 connectors are available as an option for the field housing (see "Accessories" section in Operating Instructions). The adapters connect the RJ45 Ethernet interfaces with the M12 connectors mounted in the cable entries. Therefore the connection to the Ethernet interface can be established via an M12 connector without opening the device.

5.2.8 Block diagram and terminal table

Block diagram

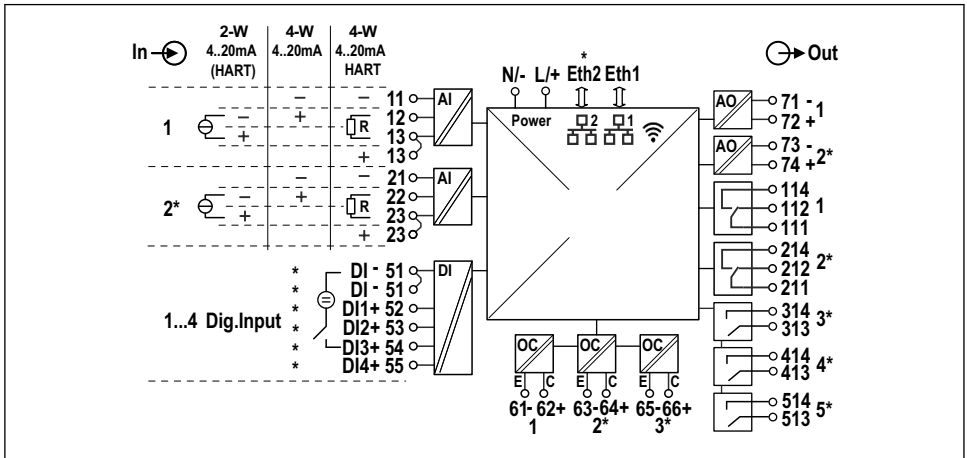

A0054893

13 Connection diagram (terminals marked with * depend on options)

Terminal table

Terminal	Terminal assignment	Description
L/+	L for AC + for DC	Power supply
N/-	N for AC - for DC	
11	Only for 4-wire: - Current measuring input	Analog input 1
12	For 2-wire: - of sensor For 4-wire: + Current measuring input For 4-wire with HART: Communication resistor	
13	For 2-wire: + of sensor For 4-wire with HART: Communication resistor	
13	Only for 4-wire with HART: + of sensor output (LPS must be disabled)	Analog input 2 (optional)
21	Only for 4-wire: - Current measuring input	
22	For 2-wire: - of sensor For 4-wire: + Current measuring input For 4-wire with HART: Communication resistor	
23	For 2-wire: + of sensor For 4-wire with HART: Communication resistor	

Terminal	Terminal assignment	Description
23	Only for 4-wire with HART: + of sensor output (LPS must be disabled)	
51 (2x)	- For digital inputs 1 to 4	Digital inputs/switch inputs (optional)
52	+ Digital input 1 (external switch 1)	
53	+ Digital input 2 (external switch 2)	
54	+ Digital input 3 (external switch 3)	
55	+ Digital input 4 (external switch 4)	
61	-	Open Collector 1
62	+	
63	-	Open collector 2 (optional)
64	+	
65	-	Open collector 3 (optional)
66	+	
71	- (0/4 to 20 mA, HART (optional))	Analog output 1
72	+ 0/4 to 20 mA	
73	- (0/4 to 20 mA)	Analog output 2 (optional)
74	+ 0/4 to 20 mA	
111	Common (COM)	Relay 1
112	Normally closed (NC)	
114	Normally open (NO)	
211	Common (COM)	Relay 2 (optional)
212	Normally closed (NC)	
214	Normally open (NO)	
313	Common (COM)	Relay 3 (optional)
314	Normally open (NO)	
413	Common (COM)	Relay 4 (optional)
414	Normally open (NO)	
513	Common (COM)	Relay 5 (optional)
514	Normally open (NO)	

5.2.9 Sensor connection

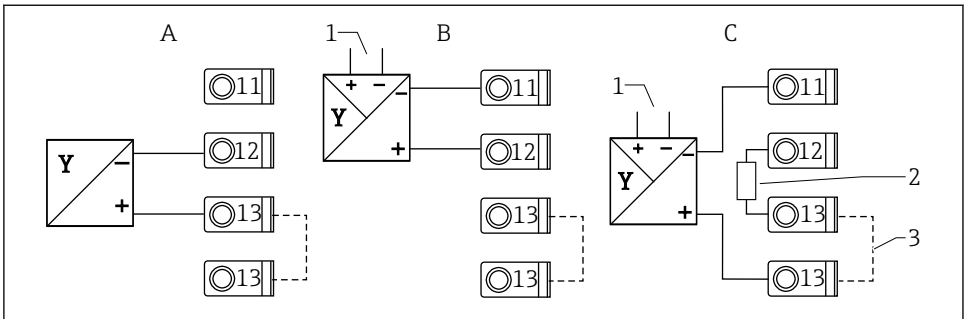

A0056613

14 Connection examples: 2-wire and 4-wire sensor on 4 to 20 mA current input or HART

A Passive 2-wire sensor (LPS switched on), e.g. FMR10B, FMR20B, FMR30B, FMX11, FMX21

B Active 4-wire sensor, 4 to 20 mA

C Active 4-wire sensor, HART (LPS switched off)

1 External power supply

2 External HART communication resistor

3 Terminal 13 and 13 jumpered internally



Observe the relevant Operating Instructions when connecting a sensor.

5.3 Special connection instructions

5.3.1 Connection of the power supply in the polycarbonate field housing

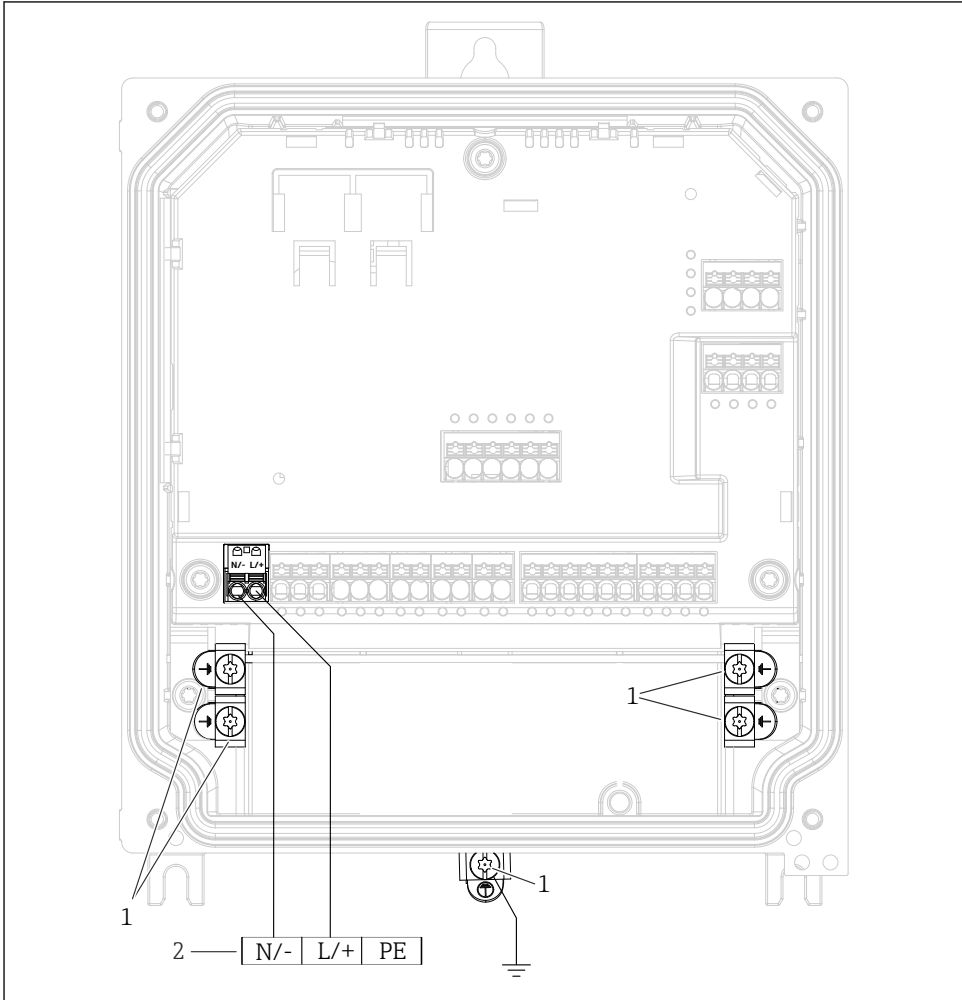

A0054329

15 Connection of the power supply in the polycarbonate field housing

- 1 Connection options for functional ground and shielding of signal lines
- 2 Connection of the power supply (see nameplate)

5.3.2 Connection of the power supply in the aluminum field housing

⚠ WARNING

Shock hazard and explosion hazard

- ▶ Connect the aluminum field housing to the potential earth (PE) and/or the local ground potential (PML) via the protective ground terminal.

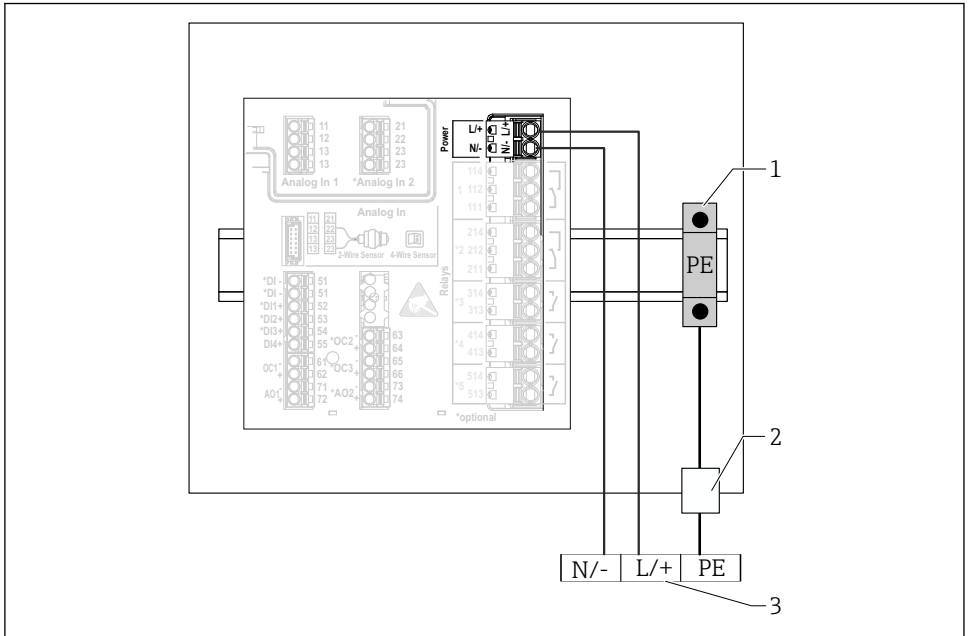

A0054325

16 Connection of the power supply in the aluminum field housing

- 1 Protective ground terminal strip (with contact to DIN rail)
- 2 Protective ground terminal on the outside of the field housing
- 3 Connection of the power supply (see nameplate)

5.3.3 Connection of the power supply on the DIN rail device

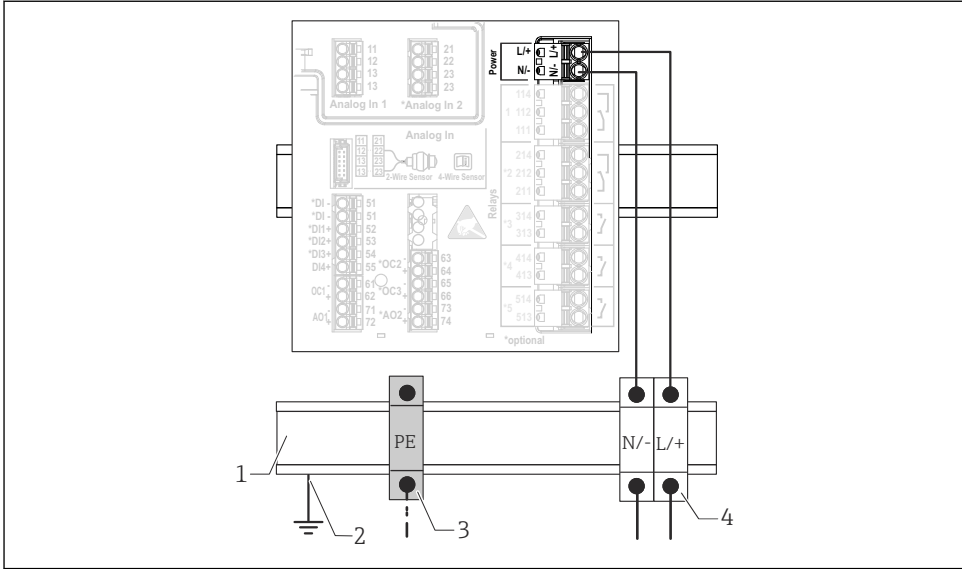

A0054327

17 Connection of the power supply on the DIN rail device

- 1 Metal DIN rail in cabinet
- 2 Grounding via DIN rail
- 3 Protective ground terminal strip (with contact to DIN rail)
- 4 Terminal blocks (no contact with DIN rail); connection of power supply (see nameplate)

5.3.4 Connection of the power supply on the panel-mounted device

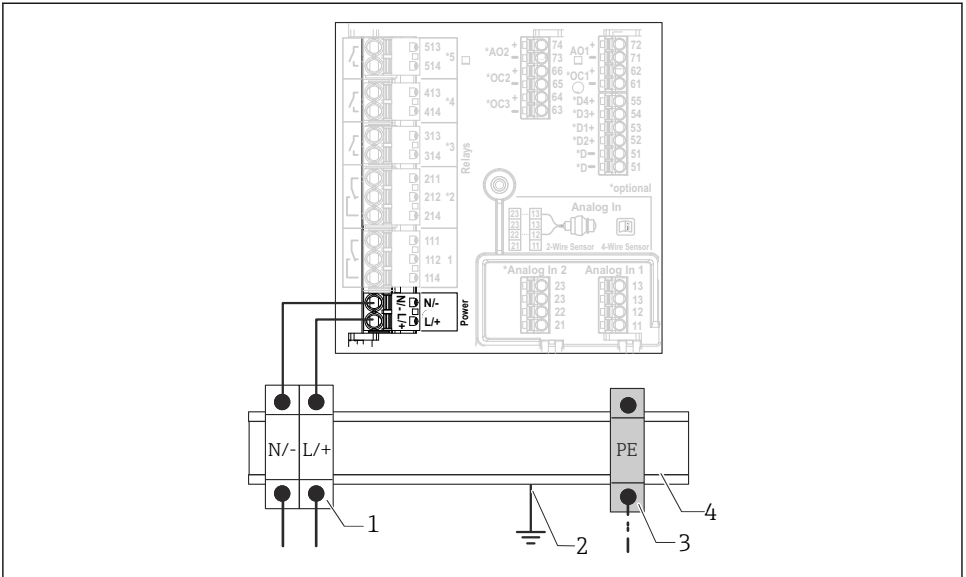

A0054326

18 Connection of the power supply on the panel-mounted device

- 1 Terminal blocks (no contact with DIN rail); connection of power supply (see nameplate)
- 2 Grounding via DIN rail
- 3 Protective ground terminal strip (with contact to DIN rail)
- 4 Metal DIN rail in cabinet

5.4 Hardware settings

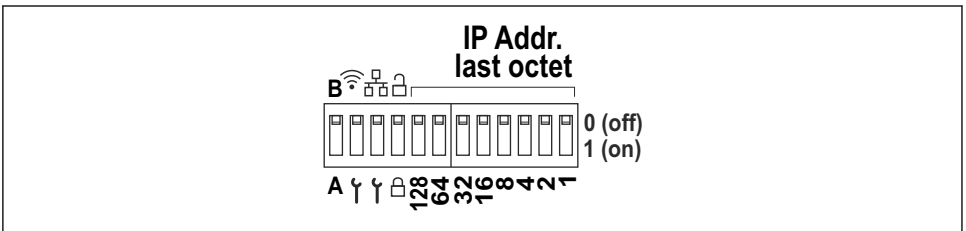

A0051998

19 DIP switch (drawing shows the delivery settings)

The following settings are made at the DIP switch (from left to right):

- A/B: Reserve (currently no function)
- Activate/deactivate the WLAN service IP address (192.168.2.212)
- Activate/deactivate the LAN service IP address (192.168.1.212)
- Write protection switch: locks the device to prevent modifications to the configuration
- 128 to 1: last octet of IP address (192.168.1.xxx) or hardware address for PROFINET



The LAN and WLAN must not be in the same subnet.

5.5 Ensuring the degree of protection

Only the mechanical and electrical connections which are described in these instructions, and which are necessary for the required intended use, may be established on the device delivered.

5.5.1 DIN rail device

The device meets all the requirements of IP20 protection.

5.5.2 Panel-mounted device

The device fulfills all the requirements for the IP65/NEMA type 4 (front) and IP20 (rear) degree of protection.

Carry out the following steps after electrical connection to ensure the degree of protection:

1. Check that the housing seal to the panel is clean and fitted correctly. Dry, clean or replace the seal if necessary.
2. Tighten all the fastening clips.

5.5.3 Field housing

The field housing fulfills all the requirements for the IP65/NEMA type 4X degree of protection.

Carry out the following steps after electrical connection to ensure the degree of protection:

1. Aluminum field housing: The device must be mounted and connected on a DIN rail in the field housing as described in this manual.
2. Polycarbonate field housing: Check that the housing seal is not damaged. Dry, clean or replace the seal if necessary.
3. Tighten all housing screws and screw covers. (Tightening torque: 1.3 Nm (1 lbf ft))
4. Firmly tighten the cable glands.
5. To ensure that moisture does not enter the cable entry, route the cable so that it loops down before the cable entry ("water trap").

5.6 Post-connection check

Device condition and specifications	Notes
Are the device and cable undamaged (visual inspection)?	-
Electrical connection	Notes
Does the supply voltage match the specifications on the nameplate?	-
Are the power supply and signal cables connected correctly?	-
Are the mounted cables strain-relieved?	-
Are all the connections of the terminals, ground terminals, etc. checked?	-
For field housing: Are the cable glands tightened correctly? Are the cover screws on the connection compartment cover firmly tightened? (Visual inspection)	-

6 Operation options

6.1 Structure and function of the operating menu

6.1.1 Structure of the operating menu

Menu	Typical tasks	Contents/Submenu ¹⁾
<p>Guidance</p>	<p>Main functions for use: From fast and reliable commissioning to guided support during operation.</p>	<ul style="list-style-type: none"> ▪ Commissioning ("Maintenance" only) This wizard guides you through the commissioning of the device. ▪ Certificate management Import of certificates for the web server or other services, as well as the creation of certificates for reliable communication. ▪ Import/Export Option for file import and export via web server
<p>Diagnostics</p>	<p>Troubleshooting and preventive maintenance: Device behavior settings for process and device events and help and measures for diagnostic purposes.</p>	<p>Contains all parameters for detecting and analyzing errors:</p> <ul style="list-style-type: none"> ▪ Active diagnostics Shows the current diagnostic message with the highest priority, the last diagnostic message and the operating time of the device ▪ Diagnostic list Shows the current diagnostic events pending ▪ Event logbook Shows all event messages in chronological order ▪ Minimum/maximum values Shows the lowest and highest electronics temperature measured to date, the minimum/maximum level values linearized to date and the minimum/maximum volume flow rate with the respective timestamps. The values can be reset. ▪ Simulation Simulation of a process variable, a pulse output or a diagnostic event ▪ Diagnostic settings Contains all parameters for configuring error events ▪ HART master Diagnostic information for checking the quality of the HART signal and HART communication

Menu	Typical tasks	Contents/Submenu ¹⁾
Application	Targeted optimization for the specific application: Comprehensive device settings from sensor technology to system integration for optimum application adjustment.	Contains all parameters for commissioning an application: <ul style="list-style-type: none"> ■ Measured values Displays the current measured values and status of the applications ■ Operating mode Use this function to select the operating mode (normal operating mode or configuration mode), as well as the logging interval and the application ■ Units Contains all parameters for configuring the engineering units ■ Sensors Contains all parameters for configuring the sensors ■ Level Contains all parameters for level configuration ■ Pump control Contains all the parameters for configuring pump control ■ Flow Contains all parameters for flow configuration ■ Backwater Contains all parameters for configuring backwater detection ■ Calculations Enables average calculations and totalizers for level and flow ■ Totalizer Enables a reset of the totalizer ■ Rake control Contains all parameters for configuring rake control ■ Digital inputs Contains all parameters for configuring the digital inputs ■ Limit values Contains all parameters for configuring the limit values ■ Current output Contains all parameters for configuring the current outputs ■ Relay Contains all parameters for configuring the relays ■ Open collector Contains all parameters for configuring the open collector outputs

Menu	Typical tasks	Contents/Submenu ¹⁾
System	Comprehensive device management and security settings: Management of system settings and adjustment to the operating requirements.	Contains all higher-level device parameters that are assigned to system, device and user management. <ul style="list-style-type: none"> ▪ Device management Contains all parameters for general device management ▪ Security Contains all parameters for device security and user administration ▪ Connectivity Contains the parameters for configuring the communication interfaces ▪ Web server Contains all parameters for the web server ▪ Display Configuration of the on-site display ▪ Date/time Configuration and display of date/time ▪ Geolocation Configuration of GPS coordinates for the device ▪ Information Contains all parameters for unique identification of the device ▪ Hardware configuration Overview of the hardware configuration ▪ Software configuration Updates, activation and overview of the software
Visualization	Tasks during operation: Create and display groups for the visualization of measured values.	Group 1 to 6 Configuration, display and visualization of the current measured values in groups
Help	Additional information on the device	Displays QR codes with external links (product page, training videos, etc.)

1) The visibility of the submenus depends on the device configuration and the selected ordering options.



For a detailed overview of all operating parameters, see the associated description of device parameters (GP)

6.2 Access to the operating menu via the local display

The device can be operated intuitively via the 3.5" TFT touch display (order option). Once switched on, the device responds by displaying the start screen. The device is operated using buttons, drop-down lists and input fields. A screen keyboard is available for alphanumeric entries. Drop-down lists and visualization menus (measured value displays) can be operated by swiping vertically/horizontally.

6.2.1 Elements on front of device with touch display



The device version without display features 3 LEDs: DS (device status), NS (network status) and WLAN status at the bottom left instead of the display

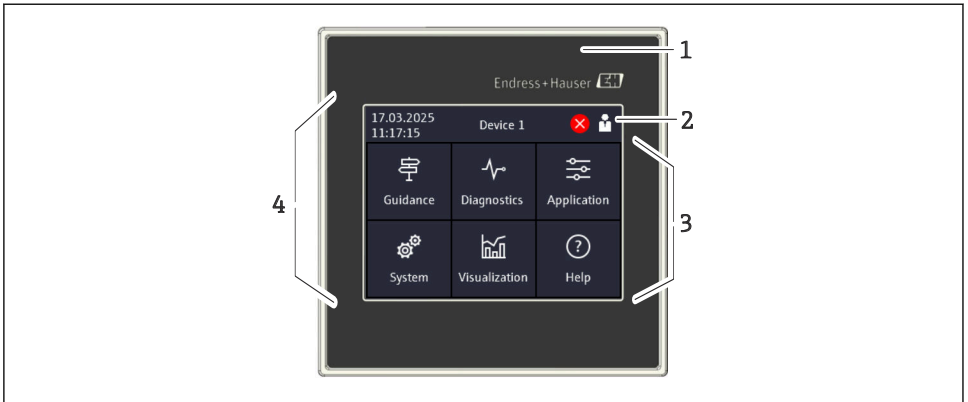

A0052679

- 1 Front of device
- 2 Header: date/time, tag name, diagnostic information, quick access menu (logging in/log out, language)
- 3 Function tiles for display and touch operation
- 4 Touch display

6.2.2 Light emitting diodes (LEDs)



The LEDs are only visible with the DIN rail version without touch display.

DS (device status): LED for operating status

- **Lit green**
Normal operation; no faults detected.
- **Flashes red**
Warning is pending. Details are saved in the diagnostic list.
- **Lit red**
Alarm is pending. Details are saved in the diagnostic list.
- **Off**
No supply voltage.

NS (network status): LED for Ethernet fieldbus

- **Lit red**
Communication active
- **Lit green**
Connection established, no active communication
- **Off**
No connection

WLAN: LED for communication

- **Flashing blue**
Searching for WLAN access point
- **Lit blue**
Connection established
- **Off**
No connection

6.2.3 Operation via touch display

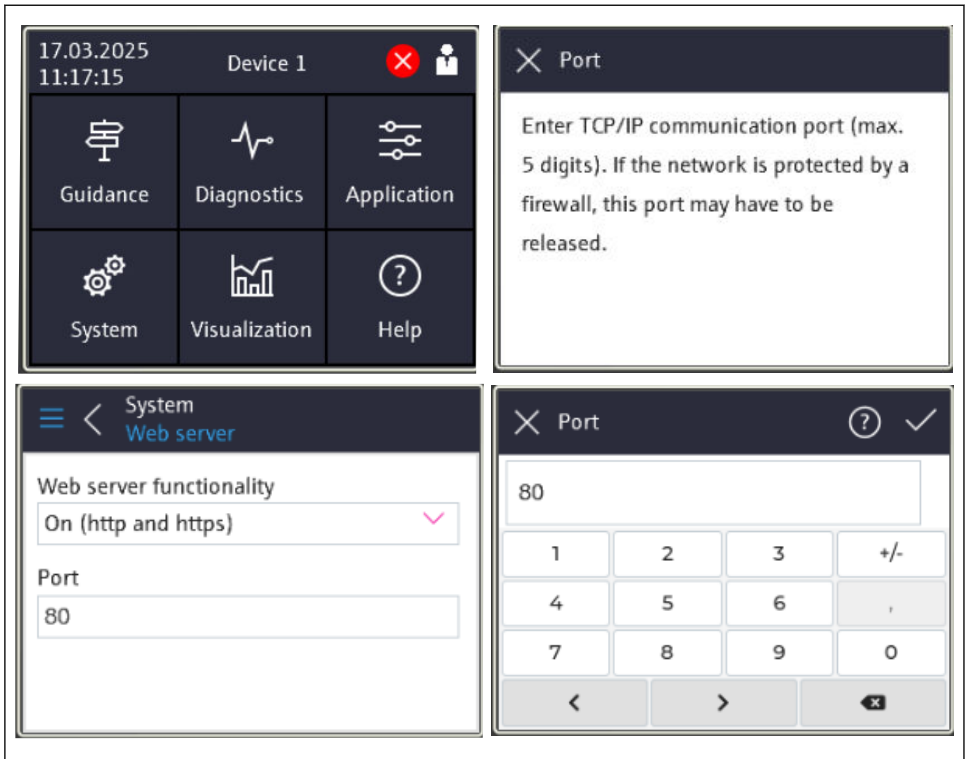

A0050353

 20 *Operating menu on the touch display: Start screen, submenu with input fields, screen keyboard, online help*

 The ✓ symbol with the "OK" or "Confirm entry" function appears in the top right of each dialog box.

The value is accepted and the dialog box closes by clicking ✓.

 The ✕ symbol with the "Back" or "Cancel" function appears in the top left of each dialog box.

Pressing ✕ closes the dialog box without accepting the value entered.

 Help: The ? symbol appears in the top right of each dialog box and can be used to call up the integrated help function.

Pressing ✕ closes help.

6.3 Access to operating menu via web browser

The device can be operated and configured via a web browser with the integrated web server. The web server is enabled when the device is delivered, but can be disabled via an appropriate parameter. For device versions with Industrial Ethernet communication types, the connection can be established at the signal transmission port via the network.

Function range

Thanks to the integrated web server, the device can be operated and configured using a web browser via the LAN or WLAN interface. The structure of the operating menu is the same as for the local display. In addition to the measured values, status information on the device is displayed which can be used to monitor device health. Furthermore the device data can be managed and the network parameters can be configured.

 A device which has a WLAN interface (optional) is required for the WLAN connection.

7 System integration

7.1 Integrating the measuring instrument into the system

 HART slave communication and Modbus TCP server communication are order options.

 For further details on system connection, see the associated Operating Instructions.

8 Commissioning

8.1 Post-installation check

Make sure that all installation and connection checks have been carried out before putting the device into operation.

NOTICE

- Before commissioning the device, make sure that the supply voltage matches the voltage specifications on the nameplate. Failure to perform these checks may result in damage to the device caused by the incorrect supply voltage.

8.2 Switching on the device

Once the supply voltage has been applied, the display or the status LED indicates that the device is ready for operation.

 Remove the protective film from the touch display as this will otherwise affect the readability of the display.

8.3 Configuring the operating language at the device

Factory setting: English or local language ordered

(Only relevant for version with touch display)

You can change the language under "Language" using the quick access menu at the top right in the header.

1. Select the required language from the "Language" drop-down list
2. Confirm selection by pressing "✓" in the top right

The operating language has been changed.

8.4 Configuring the device

Further configuration of device parameters can be carried out directly via the touch display or the web server.



For detailed information on device configuration, see the associated documentation (BA, GP, SD documentation).

NOTICE

Avoiding incorrect configuration

- ▶ Do not configure the device simultaneously via various interfaces (LAN/WLAN/touch). The device does not restrict this to facilitate (on-site) operation even in emergency situations.
- ▶ If using a device that has already been used and is not brand new from Endress+Hauser Sensors, it is recommended to perform a factory reset before commissioning.

CAUTION

Undefined switching of outputs and relays

- ▶ During configuration, the device may assume undefined states! This may result in the undefined switching of outputs (relays/OC) and the output of a failure current (current outputs).
- ▶ To counteract this, configuration mode can be activated in the **Guidance** → **Commissioning** menu or via **Application** → **Operating mode** → **Configuration mode**. This ensures that the current states of the outputs (relays/OC) are retained during configuration.

Configuration via wizard

For quick and easy commissioning, we recommend you carry out device configuration using the integrated wizard. The wizard can be called up directly via the touch display, the web server and all the operating tools (restricted).

Can be called up in **Guidance** → **Commissioning** menu

The wizard guides you through the commissioning of the device. A suitable value can be entered or the appropriate option selected for each parameter.

The following wizard is stored in the device:

- Device settings
- Application
- Outputs
- Visualization

If multiple applications are to be configured in combination, manual configuration must be selected.

If the wizard is canceled before all the necessary parameters have been configured, any settings already set are saved. For this reason, the device may then be in an undefined state. In such situations, it is advisable to reset the device to the factory default settings.

 Certain parameters are preset for the operation of the FMA90 in conjunction with Endress+Hauser sensors and are always defined by the FMA90.

8.4.1 Setup via touch display

 Recommendation:

In the **Guidance** → **Commissioning** menu: As a component in the guided device operation (Wizard)

In the **System** menu: Configure basic device settings such as language, date/time, communication etc.

In the **Application** menu, configure settings for the application in question

8.4.2 Establishing a connection and setup via web server

The device features an integrated web server, which enables access via Ethernet or WLAN. The web server is used for convenient device commissioning and configuration and to visualize measured values. Access is possible from any access point when the device is connected to an Ethernet network. Suitable IT infrastructure, security measures, etc. must be

provided according to system-specific requirements. For service purposes, point-to-point access via web server and Ethernet is particularly suitable.

Establishing a connection via WLAN (option)



The WLAN access data and applicable radio approvals are affixed to the housing on devices with the WLAN option.

For quick and easy connection during initial commissioning, scan the matrix code (QR) located there with a mobile device.

Setting up a connection manually:

Carry out the following steps to connect to the device via WLAN:

1. Network information: The information on the WLAN MAC address, network name (SSID) and network key (WLAN password) is located outside the device.
2. Enable WLAN on the device under **System** → **Connectivity** → **WLAN** → **Configuration** → **WLAN** (= factory setting). Confirm changes with "Apply".
3. Enable WLAN on the mobile device: Enable the WLAN in the settings for the device to be connected (e.g. laptop, smartphone).
4. Select network: In the list of available networks, search for the network name (SSID) provided by the device.
5. When prompted, enter the network key (WLAN password) provided on the device (case-sensitive).
6. Connect: Click "Connect" or a similar button to connect to the WLAN network.



If you have problems connecting, check that the password is correct, check the range of the WLAN network for the device and restart the router and the device if necessary.

It is recommended to change the network key for the WLAN after the device has been set up. For security, use a combination of upper and lower case letters, numbers, and symbols. Note: After this change, the matrix code (QR) on the device is no longer valid.

We recommend you disable the "Connect automatically" function for this network on the mobile device (e.g. laptop, smartphone), as otherwise the terminal will inadvertently connect to the device instead of the company network.

Establishing a connection via Ethernet

The device is equipped with one or two (order option) RJ45 Ethernet ports. They can be used to build point-to-point, star or ring topologies. Both RJ45 ports are identical in terms of their functionality.



A crossover cable is not required.

When connecting via LAN to a company network: please contact your system administrator.

The LAN and WLAN must not be in the same subnet.

Device version with touch display

Procedure to establish a direct connection via Ethernet (point-to-point connection):

1. Retrieve the Ethernet settings such as IP address etc. on the device under **System** → **Connectivity** → **Ethernet** → **Information**
2. Disable DHCP on the device under **System** → **Connectivity** → **Ethernet** → **Configuration**
3. Connect the PC to the device using a LAN cable
4. Set the IP address on the PC (network part: octets 1 to 3 must match the device; host part: octet 4 must differ, e.g: 192.168.1.**213**)
5. Set the subnet mask on the PC: 255.255.255.0

Device version without touch display

Procedure to establish a direct connection via Ethernet (point-to-point connection):

 Note: The following activation of the LAN Service IP address via DIP switch will interrupt communication to the network!

1. Activate the service IP address 192.168.1.212 using DIP switch 3 on the device
2. Connect the PC to the device using a LAN cable
3. Set the IP address on the PC (network part: octets 1 to 3 must match the device; host part: octet 4 must differ, e.g: 192.168.1.**213**)
4. Set the subnet mask on the PC: 255.255.255.0

Setup via web server

To activate the web server: go to the menu **System** → **Web server** → **Web server functionality** → **On (http and https)** (factory setting)

The web server port is preset to 80. The port and the language of the web server can be changed directly in this menu. The factory setting of the language is English.



To establish a secure https connection to the web server, a corresponding X.509 certificate must be stored on the device.

Certificate management is available under **Guidance** → **Certificate management**.

For more information on certificate management: Refer to the relevant Operating Instructions (BA), as well as the Description of Device Parameters (GP)



If the network is protected by a firewall, the port may need to be activated.



Authentication as operator is required to configure the device via web server ("Operator" or "Maintenance"). The initial device PIN for both accounts is **0000**.

PIN management is available under **System** → **Security**.

Note: The initial device PIN should be changed during commissioning!



In order to use the full functionality of the Web server, it is recommended that the latest version of the browser is used.

A minimum resolution of 1920x1080 (full HD) is recommended.



It is not possible to access the web server from multiple devices simultaneously via both WLAN and Ethernet.

Establishing a connection to the web server:

1. Connect the PC with the device via Ethernet or WLAN (optional). Pay attention to the DIP switch settings!
2. Start the browser on the PC or on the mobile device
3. Enter the device's IP address in the browser **http://<ip address>** or **https://<ip address>**. Note: Leading zeros in IP addresses must not be entered. **LAN: 192.168.1.212, WLAN: 192.168.2.212**
4. Select "Maintenance" (for parameter configuration) or "Operator" user ID, enter the device PIN and confirm with "Login".

The web server responds with the start screen and device operation or parameter configuration can be started.

9 Maintenance

No special maintenance work is required for the device.

9.1 Cleaning

A clean, dry cloth can be used to clean the device.



71773405

www.addresses.endress.com
