

# Technical Information

## Proline Promag 55S

Electromagnetic flowmeter



The flowmeter with outstanding abrasion resistance and integrated solids content diagnostics

### Application

- The bidirectional measuring principle is virtually independent of pressure, density, temperature and viscosity
- Ideal for the most demanding applications with high solids content and high abrasion

### Device properties

- Intensified coil system
- Large range of liners
- Solids content up to 80% by weight
- 4-line backlit display with touch control
- Two switch outputs
- HART, PROFIBUS PA/DP, FOUNDATION Fieldbus

### Your benefits

- Superb signal stability due to unique signal processing
- Maximum safety – industry-optimized measuring electrodes and linings
- Energy-saving flow measurement – no pressure loss due to cross-section constriction
- Maintenance-free – no moving parts
- Highest performance – with integrated solids measurement for demanding fluids
- Highest safety – integrated electrode cleaning
- Automatic recovery of data for servicing

## Table of contents

|  |           |   |           |
|--|-----------|---|-----------|
| <b>Function and system design</b> .....        | <b>3</b>  | Pressure tightness (lining) .....       | 23        |
| Measuring principle .....                      | 3         | Limiting flow .....                     | 25        |
| Measuring system .....                         | 3         | Pressure loss .....                     | 26        |
|  |           | Vibrations .....                        | 26        |
| <b>Input</b> .....                             | <b>4</b>  | <b>Mechanical construction</b> .....    | <b>27</b> |
| Measured variable .....                        | 4         | Design, dimensions .....                | 27        |
| Measuring ranges .....                         | 4         | Weight .....                            | 37        |
| Operable flow range .....                      | 4         | Measuring tube                          |           |
| Input signal .....                             | 4         | specifications .....                    | 39        |
|  |           | Material .....                          | 41        |
| <b>Output</b> .....                            | <b>4</b>  | Fitted electrodes .....                 | 42        |
| Output signal .....                            | 4         | Process connections .....               | 42        |
| Signal on alarm .....                          | 5         | Surface roughness .....                 | 42        |
| Load .....                                     | 5         | <b>Operability</b> .....                | <b>43</b> |
| Low flow cut off .....                         | 5         | Local operation .....                   | 43        |
| Galvanic isolation .....                       | 5         | Language groups .....                   | 43        |
| Switching output .....                         | 5         | Remote operation .....                  | 43        |
|  |           | <b>Certificates and approvals</b> ..... | <b>44</b> |
| <b>Power supply</b> .....                      | <b>6</b>  | CE mark .....                           | 44        |
| Terminal assignment .....                      | 6         | C-tick symbol .....                     | 44        |
| Supply voltage .....                           | 6         | Ex approval .....                       | 44        |
| Power consumption .....                        | 6         | Sanitary compatibility .....            | 44        |
| Power supply failure .....                     | 6         | Pressure equipment directive .....      | 44        |
| Electrical connection .....                    | 7         | FOUNDATION Fieldbus certification ..... | 44        |
| Electrical connection, remote version .....    | 8         | PROFIBUS DP/PA certification .....      | 44        |
| Potential equalization .....                   | 8         | Other standards and guidelines .....    | 44        |
| Cable entries .....                            | 11        | <b>Ordering information</b> .....       | <b>45</b> |
| Remote version cable                           |           | <b>Accessories</b> .....                | <b>45</b> |
| specifications .....                           | 11        | <b>Documentation</b> .....              | <b>45</b> |
|  |           | <b>Registered trademarks</b> .....      | <b>45</b> |
| <b>Performance characteristics</b> .....       | <b>13</b> |   |           |
| Reference operating                            |           |   |           |
| conditions .....                               | 13        |   |           |
| Maximum measured error .....                   | 13        |   |           |
| Repeatability .....                            | 13        |   |           |
| <b>Installation</b> .....                      | <b>14</b> |   |           |
| Mounting location .....                        | 14        |   |           |
| Orientation .....                              | 16        |   |           |
| Inlet and outlet runs .....                    | 17        |   |           |
| Adapters .....                                 | 17        |   |           |
| Length of connecting cable .....               | 18        |   |           |
| Foundations, supports .....                    | 18        |   |           |
| <b>Environment</b> .....                       | <b>19</b> |   |           |
| Ambient temperature range .....                | 19        |   |           |
| Storage temperature .....                      | 19        |   |           |
| Degree of protection .....                     | 19        |   |           |
| Shock and vibration resistance .....           | 19        |   |           |
| Electromagnetic compatibility (EMC) .....      | 19        |   |           |
| <b>Process</b> .....                           | <b>20</b> |   |           |
| Medium temperature range .....                 | 20        |   |           |
| Conductivity .....                             | 21        |   |           |
| Pressure-temperature ratings .....             | 21        |   |           |
| Medium pressure range (nominal pressure) ..... | 23        |   |           |

## Function and system design

### Measuring principle

Faraday's law of induction states that a voltage is induced in a conductor moving in a magnetic field. In electromagnetic measuring, the flowing medium corresponds to the moving conductor. The induced voltage is proportional to the flow velocity and is detected by two measuring electrodes and transmitted to the amplifier. Flow volume is computed on the basis of the pipe's diameter. The constant magnetic field is generated by a switched direct current of alternating polarity.

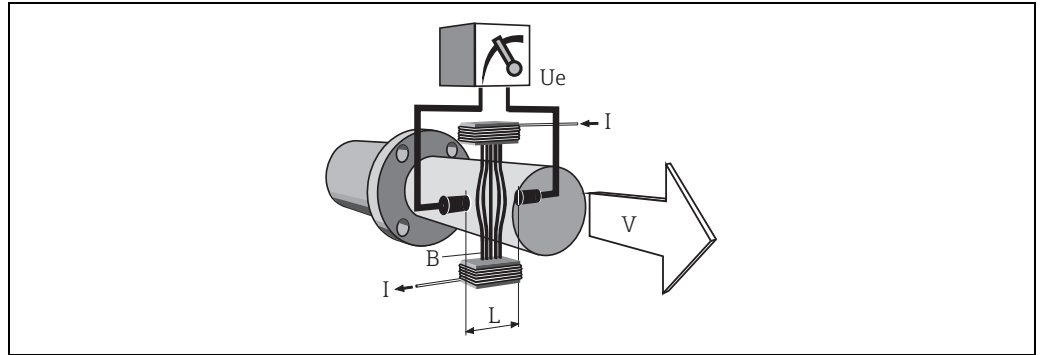

$$U_e = B \cdot L \cdot v$$

$$Q = A \cdot v$$

- $U_e$  induced voltage
- $B$  magnetic induction (magnetic field)
- $L$  electrode gap
- $v$  flow velocity
- $Q$  volume flow
- $A$  pipe cross-section
- $I$  current strength

A0003191

### Measuring system

The flow measuring system consists of the following components:

- Promag 55 transmitter
- Promag S sensor (DN 15 to 600 / ½ to 24")

Two versions are available:

- Compact version: Transmitter and sensor form a single mechanical unit.
- Remote version: Transmitter and sensor are installed separately.

### Measurement of solids flow rates

In combination with a density meter, e.g. with "Gammapiilot M" from Endress+Hauser, Promag 55S also determines the throughput of solids in mass, volume or percentage rates.

The following order specifications are required for this: order option for software function "Solids content flow" (F-CHIP) and order option for a current input.

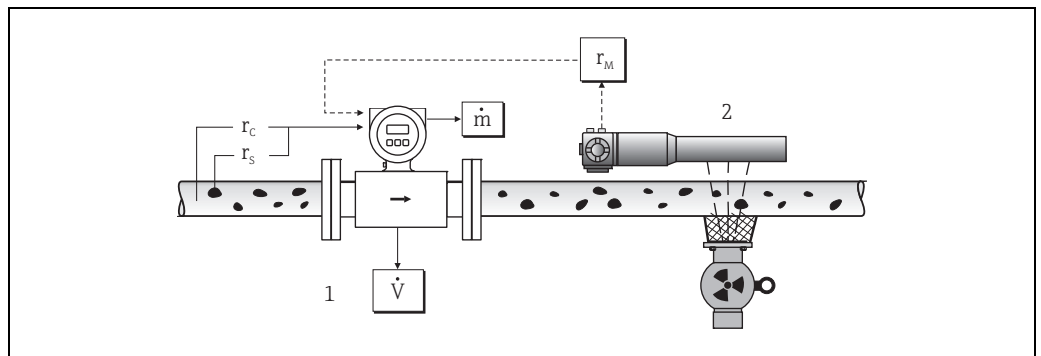

A0006118

Solids content flow measurement ( $\dot{m}$ ) with the aid of a density and flow measuring device. If the solid density ( $\rho_s$ ) and the density of the carrier liquid ( $\rho_c$ ) are also known, they can be used to calculate the solids flow.

- 1 Flow measuring device (Promag 55S) → volume flow ( $V$ ). The solid density ( $\rho_s$ ) and the density of the transport liquid ( $\rho_c$ ) must be entered in the transmitter.
- 2 Density measuring device (e.g. "Gammapiilot M") → total fluid density ( $\rho_M$ ) (transport liquid and solids)

## Input

|                            |  |
|----------------------------|--|
| <b>Measured variable</b>   | <ul style="list-style-type: none"> <li>▪ Flow rate (proportional to induced voltage)</li> <li>▪ Conductivity (without temperature compensation)</li> </ul>   |
| <b>Measuring ranges</b>    | <ul style="list-style-type: none"> <li>▪ Flow rate: Typical <math>v = 0.01</math> to <math>10</math> m/s (<math>0.03</math> to <math>33</math> ft/s) with the specified measuring accuracy</li> <li>▪ Conductivity <math>s = 5</math> to <math>2000</math> <math>\mu\text{S}/\text{cm}</math><br/>not for sensors without reference electrode (Promag S with brush electrodes)</li> </ul>  |
| <b>Operable flow range</b> | Over 1000 : 1  |
| <b>Input signal</b>        | <p><b>Status input (auxiliary input)</b></p> <p><math>U = 3</math> to <math>30</math> V DC, <math>R_i = 5</math> k<math>\Omega</math>, galvanically isolated<br/>Configurable for: totalizer(s) reset, positive zero return, error-message reset</p> <p><b>Status input (auxiliary input) with PROFIBUS DP</b></p> <p><math>U = 3</math> to <math>30</math> V DC, <math>R_i = 3</math> k<math>\Omega</math>, galvanically isolated.<br/>Switch level: <math>\pm 3 \dots \pm 30</math> V DC, independent of polarity.<br/>Configurable for: positive zero return, error message reset, zero point adjustment start</p> <p><b>Current input</b></p> <p>Active/passive selectable, galvanically isolated, full scale value adjustable, resolution: <math>3</math> <math>\mu\text{A}</math>,<br/>temperature coefficient: typically <math>0.005\%</math> o.f.s./<math>^{\circ}\text{C}</math> (<math>0.003\%</math> o.f.s./<math>^{\circ}\text{F}</math>)</p> <ul style="list-style-type: none"> <li>▪ Active: <math>4</math> to <math>20</math> mA, <math>R_i \leq 150</math> <math>\Omega</math>, <math>U_{\text{out}} = 24</math> V DC, short-circuit proof</li> <li>▪ Passive: <math>0/4</math> to <math>20</math> mA, <math>R_i \leq 150</math> <math>\Omega</math>, <math>U_{\text{max}} = 30</math> V DC</li> </ul> |

## Output

|                      |   |
|----------------------|---|
| <b>Output signal</b> | <p><b>Current output</b></p> <p>Active/passive selectable, galvanically isolated, time constant selectable (<math>0.01</math> to <math>100</math> s),<br/>full scale value adjustable, temperature coefficient: typically <math>0.005\%</math> o.f.s./<math>^{\circ}\text{C}</math> (<math>0.003\%</math> o.f.s./<math>^{\circ}\text{F}</math>),<br/>resolution: <math>0.5</math> <math>\mu\text{A}</math></p> <ul style="list-style-type: none"> <li>▪ Active: <math>0/4</math> to <math>20</math> mA, <math>R_L &lt; 700</math> <math>\Omega</math> (for HART: <math>R_L \geq 250</math> <math>\Omega</math>)</li> <li>▪ Passive: <math>4</math> to <math>20</math> mA; supply voltage <math>V_S</math>: <math>18</math> to <math>30</math> V DC; <math>R_i \geq 150</math> <math>\Omega</math></li> </ul> <p><b>Pulse/frequency output</b></p> <p>Active/passive selectable (Ex i version passive only), galvanically isolated</p> <ul style="list-style-type: none"> <li>▪ Active: <math>24</math> V DC, <math>25</math> mA (max. <math>250</math> mA over <math>20</math> ms), <math>R_L &gt; 100</math> <math>\Omega</math></li> <li>▪ Passive: open collector, <math>30</math> V DC, <math>250</math> mA</li> <li>▪ Frequency output: end frequency <math>2</math> to <math>10000</math> Hz (<math>f_{\text{max}} = 12500</math> Hz), on/off ratio 1:1,<br/>pulse width max. <math>10</math> s</li> <li>▪ Pulse output: pulse value and pulse polarity selectable, pulse width configurable (<math>0.05</math> to <math>2000</math> ms)</li> </ul> <p><b>PROFIBUS DP interface</b></p> <ul style="list-style-type: none"> <li>▪ Transmission technology (Physical Layer): RS485 according to ASME/TIA/EIA-485-A: 1998,<br/>galvanically isolated</li> <li>▪ Profile Version 3.0</li> <li>▪ Data transmission rate: <math>9.6</math> kBaud to <math>12</math> MBaud</li> <li>▪ Automatic identification of data transmission rate</li> <li>▪ Function blocks: <math>2 \times</math> analog input, <math>3 \times</math> totalizer</li> <li>▪ Output data: volume flow, calculated mass flow, totalizer 1 to 3</li> <li>▪ Input data: positive zero return (ON/OFF), totalizer control, value for local display</li> <li>▪ Cyclic data transmission compatible with previous model Promag 35S</li> <li>▪ Bus address adjustable via miniature switches or local display (optional) at the measuring device</li> <li>▪ Available output combination <math>\rightarrow</math> 6</li> </ul> |
|----------------------|---|

**PROFIBUS PA interface**

- Transmission technology (Physical Layer): IEC 61158-2 (MBP), galvanically isolated
- Profile version 3.0
- Current consumption: 11 mA
- Permissible supply voltage: 9 to 32 V
- Bus connection with integrated reverse polarity protection
- Error current FDE (Fault Disconnection Electronic): 0 mA
- Function blocks: 2 × analog input, 3 × totalizer
- Output data: volume flow, calculated mass flow, totalizer 1 to 3
- Input data: positive zero return (ON/OFF), totalizer control, value for local display
- Cyclic data transmission compatible with previous model Promag 35S
- Bus address adjustable via miniature switches or local display (optional) at the measuring device

**FOUNDATION Fieldbus interface**

- FOUNDATION Fieldbus H1
- Transmission technology (Physical Layer): IEC 61158-2 (MBP), galvanically isolated
- ITK version 5.01
- Current consumption: 12 mA
- Inrush current: < 12 mA
- Error current FDE (Fault Disconnection Electronic): 0 mA
- Permissible supply voltage: 9 to 32 V
- Bus connection with integrated reverse polarity protection
- Function blocks:
  - 5 × Analog Input (execution time: 18 ms each)
  - 1 × PID (25 ms)
  - 1 × Digital Output (18 ms)
  - 1 × Signal Characterizer (20 ms)
  - 1 × Input Selector (20 ms)
  - 1 × Arithmetic (20 ms)
  - 1 × Integrator (18 ms)
- Total VCRs: 48
- Total link objects in VFD: 40
- Output data: volume flow, calculated mass flow, temperature, totalizer 1 to 3
- Input data: positive zero return (ON/OFF), reset totalizer
- Link Master (LM) functionality is supported

---

|                           |   |
|---------------------------|---|
| <b>Signal on alarm</b>    | <p><b>Current output</b></p> <p>Failsafe mode selectable (e.g. according to NAMUR recommendation NE 43)</p> <p><b>Pulse/frequency output</b></p> <p>Failsafe mode selectable</p> <p><b>Relay output</b></p> <p>"de-energized" in the event of a fault or power supply failure</p> <p><b>PROFIBUS DP/PA</b></p> <p>Status and alarm messages in accordance with PROFIBUS Profile Version 3.0</p> |
| <b>Load</b>               | See "output signal"   |
| <b>Low flow cut off</b>   | Switch points for low flow freely selectable.   |
| <b>Galvanic isolation</b> | All circuits for inputs, outputs, and power supply are galvanically isolated from each other.   |
| <b>Switching output</b>   | <p><b>Relay output</b></p> <p>Normally closed (NC or break) or normally open (NO or make) contacts available (default: relay 1 = NO, relay 2 = NC), max. 30 V / 0.5 A AC; 60 V / 0.1 A DC, galvanically isolated. Configurable for: error messages, empty pipe detection (EPD), direction of flow, limit values.</p>  |

---

## Power supply

### Terminal assignment

| Order code for<br>"Input / Output"                   | Terminal No.    |                    |                           |                          |
|--|-----------------|--------------------|---------------------------|--------------------------|
|  | 20 (+) / 21 (-) | 22 (+) / 23 (-)    | 24 (+) / 25 (-)           | 26 (+) / 27 (-)          |
| <i>Fixed communication boards (fixed assignment)</i> |                 |                    |                           |                          |
| A  | -               | -                  | Frequency output          | Current output<br>HART   |
| B  | Relay output 2  | Relay output 1     | Frequency output          | Current output<br>HART   |
| H  | -               | -                  | -                         | PROFIBUS PA              |
| J  | -               | -                  | +5V (ext.<br>termination) | PROFIBUS DP              |
| K  | -               | -                  | -                         | FOUNDATION<br>Fieldbus   |
| <i>Flexible communication boards</i>                 |                 |                    |                           |                          |
| C  | Relay output 2  | Relay output 1     | Frequency output          | Current output<br>HART   |
| D  | Status input    | Relay output       | Frequency output          | Current output<br>HART   |
| L  | Status input    | Relay output 2     | Relay output 1            | Current output<br>HART   |
| M  | Status input    | Frequency output 2 | Frequency output 1        | Current output<br>HART   |
| P  | Current output  | Frequency output   | Status input              | PROFIBUS DP              |
| V  | Relay output 2  | Relay output 1     | Status input              | PROFIBUS DP              |
| 2  | Relay output    | Current output 2   | Frequency output          | Current output 1<br>HART |
| 3  | Current input   | Current output 2   | Frequency output          | Current output 1<br>HART |
| 4  | Current input   | Relay output       | Frequency output          | Current output<br>HART   |
| 5  | Status input    | Current input      | Frequency output          | Current output<br>HART   |

### Supply voltage

20 to 260 V AC, 45 to 65 Hz  
20 to 64 V DC

### Power consumption

AC: < 45 VA at 260 V AC; < 32 VA at 110 V AC (incl. sensor)  
DC: < 19 W (including sensor)

Switch-on current:

- Max. 2.5 A (< 200 ms) at 24 V DC
- Max. 2.5 A (< 5 ms) at 110 V AC
- Max. 5.5 A (< 5 ms) at 260 V AC

### Power supply failure

Lasting min. 1 power cycle:

- EEPROM or HistoROM/T-DAT saves measuring system data if power supply fails
- HistoROM/S-DAT: exchangeable data storage device which stores sensor characteristic data (nominal diameter, serial number, calibration factor, zero point etc.)

Electrical connection

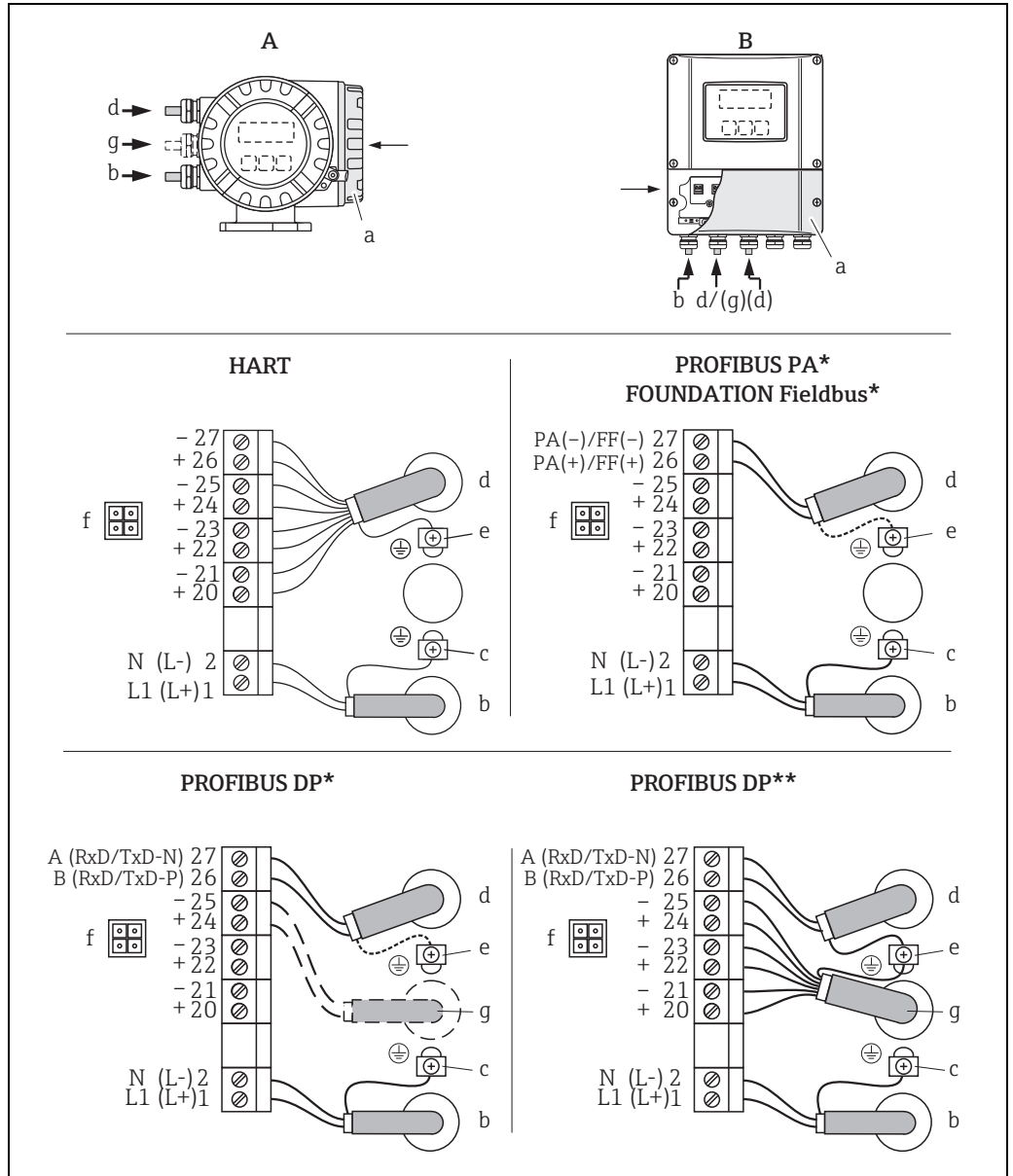

A0015195

Connecting the transmitter, cable cross-section max. 2.5 mm<sup>2</sup> (14 AWG)

A View A (field housing)

B View B (wall-mount housing)

\*) Fixed communication boards

\*\*) Flexible communication boards

a Connection compartment cover

b Cable for power supply: 20 to 260 V AC / 20 to 64 V DC

- Terminal No. 1: L1 for AC, L+ for DC

- Terminal No. 2: N for AC, L- for DC

c Ground terminal for protective conductor

d Input/output cable: see Terminal assignment → 6

Fieldbus cable:

- Terminal No. 26: DP (B) / PA (+) / FF (+): with polarity protection

- Terminal No. 27: DP (A) / PA (-) / FF (-): with polarity protection

e Ground terminal for input/output cable / Fieldbus cable

f Service adapter for connecting service interface FXA193 (Fieldcheck, FieldCare)

g Electrode cable: see Terminal assignment → 6

Cable for external termination (only for PROFIBUS DP with permanent assignment communication board):

- Terminal No. 24: +5 V

- Terminal No. 25: DGND

## Electrical connection, remote version

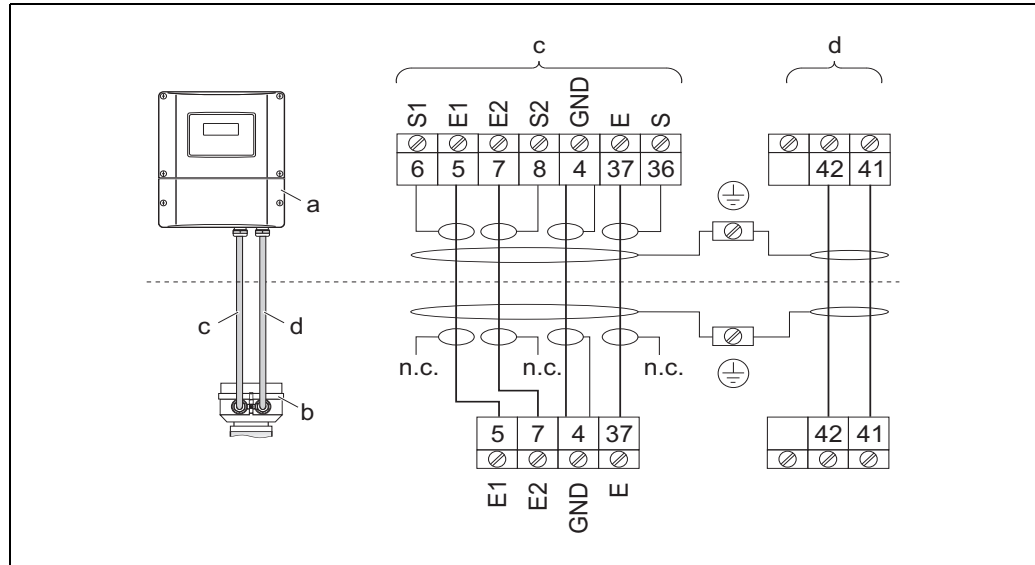

### Connecting the remote version

- a Connection compartment, wall-mount housing  
 b Cover of connection housing, sensor  
 c Electrode cable  
 d Coil current cable  
 n.c. unconnected, insulated cable shields

Terminal no. and cable colors: 6/5 = brown; 7/8 = white; 4 = green; 36/37 = yellow

## Potential equalization

### Standard case

Perfect measurement is only ensured when the medium and the sensor have the same electrical potential. Most Promag sensors have a reference electrode installed as standard, which guarantees the required potential equalization. This usually means that additional potential equalization measures are unnecessary.

#### Promag S:

- Reference electrode is standard for electrode materials 1.4435/316L, Alloy C-22, tantalum, titanium Gr. 2, Duplex 1.4462, tungsten carbide coating (for electrodes made of 1.4435)
- Reference electrode is optional for electrode material platinum
- Reference electrode not present in measuring tubes with a natural rubber lining in conjunction with brush electrodes



#### Note!

For installation in metal pipes, it is advisable to connect the ground terminal of the transmitter housing to the piping. Also, observe company-internal grounding guidelines.

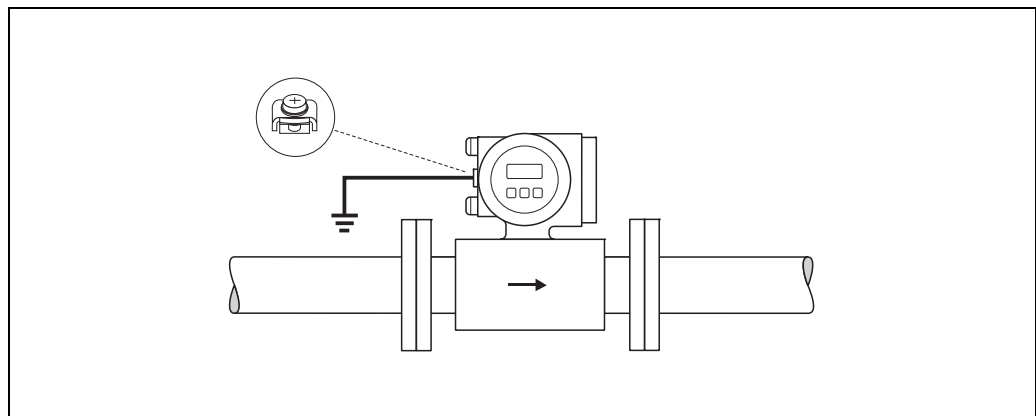

Potential equalization by means of the transmitter's ground terminal



Note!

- For sensors without reference electrodes or without metal process connections, carry out potential equalization as per the instructions for special cases described below. These special measures are particularly important when standard grounding practice cannot be ensured or extremely strong matching currents are expected.
- Sensors with brush electrodes do not have a reference electrode. For this reason, ground disks must be installed if necessary to ensure sufficient potential equalization to the fluid. This applies in particular to isolating lined pipes which are not grounded → 9.

### Special cases

#### *Metal, ungrounded piping*

In order to prevent outside influences on measurement, it is necessary to use ground cables to connect each sensor flange to its corresponding pipe flange and ground the flanges. Connect the transmitter or sensor connection housing, as applicable, to ground potential by means of the ground terminal provided for the purpose (see diagram).

The ground cable for flange-to-flange connections can be ordered separately as an accessory from Endress+Hauser → 45.

- $DN \leq 300$  (12"): The ground cable is in direct connection with the conductive flange coating and is secured by the flange screws (A).
- $DN \geq 350$  (14"): The ground cable connects directly to the metal transport bracket (B).



Note!

Also, observe company-internal grounding guidelines.

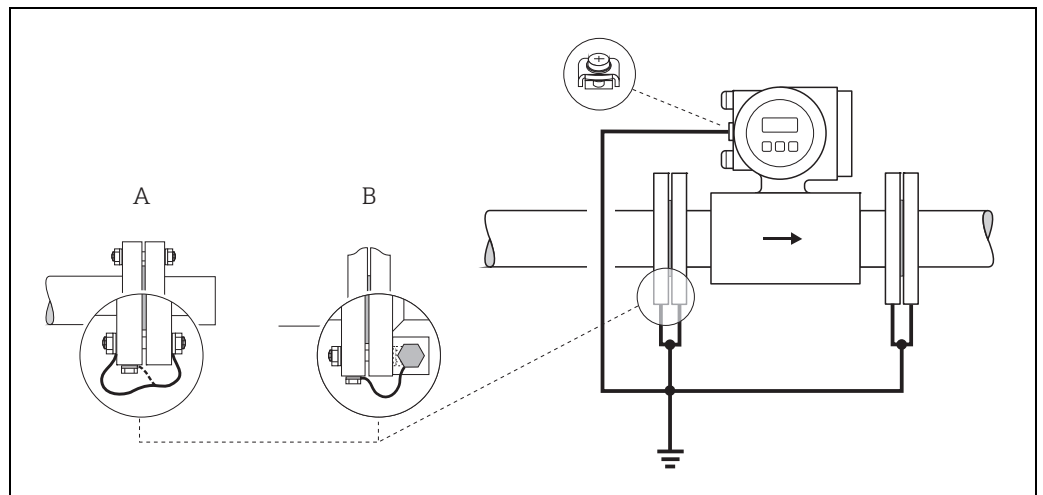

Potential equalization with equalizing currents in ungrounded, metal pipes  
(ground cable: copper wire, at least  $6 \text{ mm}^2$  / 10 AWG)

- A Installing ground cable at  $DN \leq 300$  (12")  
B Installing ground cable at  $DN \geq 350$  (14")

#### *Pre-installed ground cable for $DN \leq 300$ (12") (order option)*

Ground cables which are preinstalled on the sensor flange, are also available. These ground cables can be mounted and connected electrically to the piping in different ways:

- Using a screw on the side of the pipe flange (a)
- Using the flange screws (b)
- Using a pipe clip installed around the pipe (c)

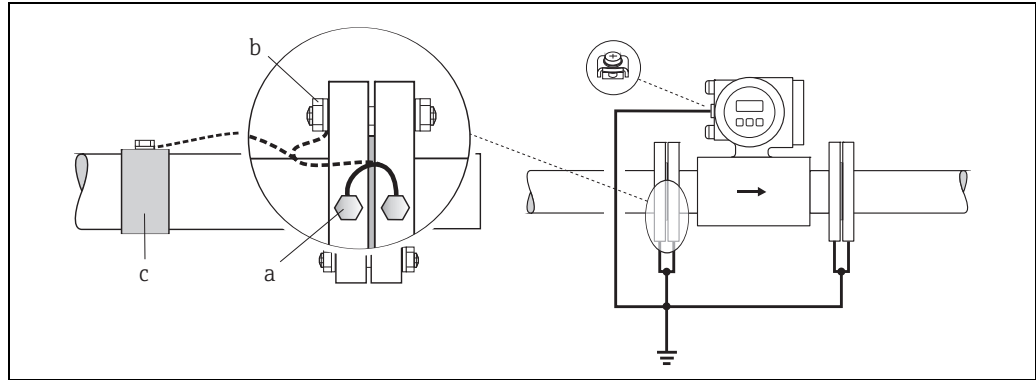

Possibilities for connecting and mounting pre-installed ground cables  
(ground cable: copper wire at least 6 mm<sup>2</sup> / 10 AWG)

### Plastic pipes and isolating lined pipes

Normally, potential is matched using the reference electrodes in the measuring tube. However, in exceptional cases it is possible that, due to the grounding plan of a system, matching currents flow over the reference electrodes. This can lead to destruction of the sensor, e.g. through electro-chemical decomposition of the electrodes. In such cases, e.g. for fiberglass or PVC pipings, it is therefore **essential** that you use additional ground disks for potential equalization. This applies also to two-phase or two-component flow, where the fluid is not well mixed or its constituents are not mixable.



Note!

- Risk of damage by electrochemical corrosion. Note the electrochemical insulation rating, if the ground disks and measuring electrodes are made of different materials.
- Also, observe company-internal grounding guidelines.

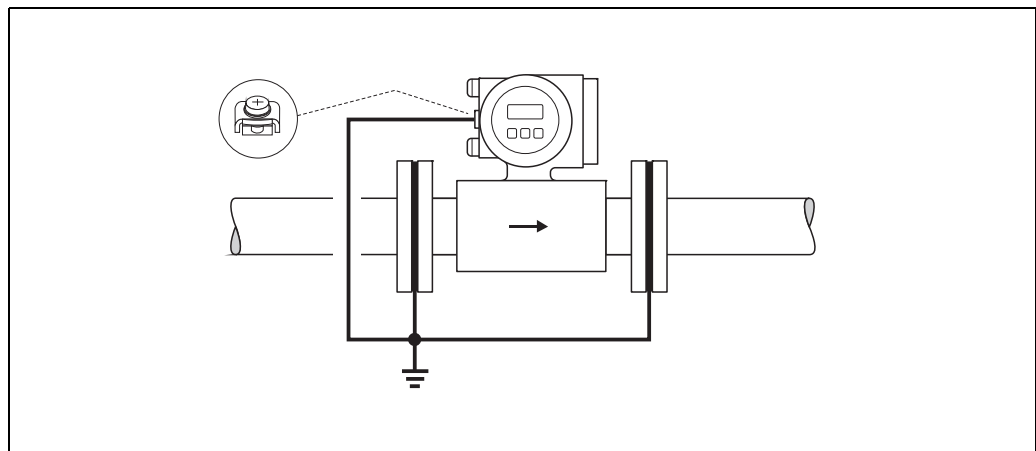

Potential equalization/ground disks in the case of plastic pipes or isolating lined pipes  
(ground cable: copper wire at least 6 mm<sup>2</sup> / 10 AWG)

### Plastic pipes and isolating lined pipes

In such cases, install the measuring instrument without potential in the piping:

- When installing the measuring device, make sure that there is a terminal assignment between the two piping runs (copper wire, at least 6 mm<sup>2</sup> / 10 AWG).
- When using ground disks in plastic or isolating lined pipes, ensure that they are electrically connected with each other (copper wire at least 6 mm<sup>2</sup> / 10 AWG).
- Make sure that the mounting material used does not establish a conductive connection between the pipe and the measuring device and that the mounting material withstands the torques applied when the threaded fasteners are tightened during installation.
- Check the galvanic isolation using an insulation tester (protection against contact).
- Also comply with the regulations applicable to potential-free installation.

**Note!**

For the remote version, both the sensor and the transmitter must be installed so that they are potential-free.

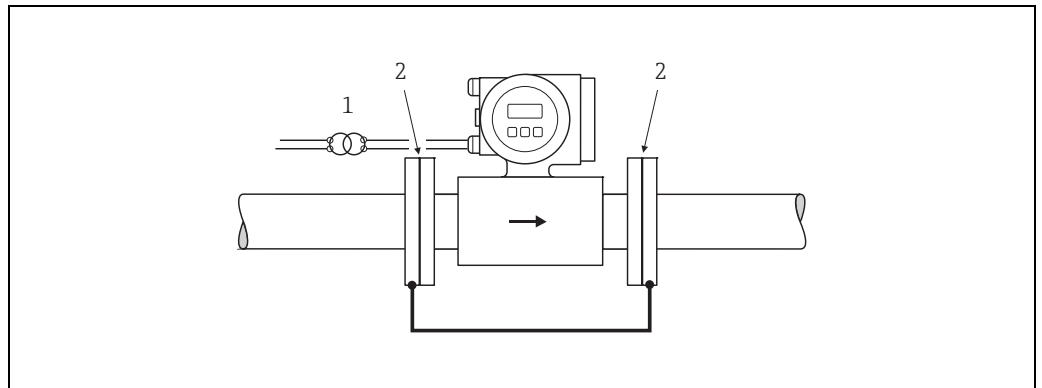

Potential equalization and cathodic protection (connecting cable: copper wire at least 6 mm<sup>2</sup> / 10 AWG)

- 1 Isolation transformer power supply  
2 Electrically insulated

**Cable entries**

Power-supply and electrode cables (inputs/outputs):

- Cable gland M20 × 1.5 (8 to 12 mm / 0.31 to 0.47")
- Cable entries for thread ½" NPT, G ½"

Fieldbus cable:

- Fieldbus connector for PROFIBUS PA, M12 × 1 / PG 13.5 plus adapter PG 13.5 / M20.5
- Fieldbus connector for FOUNDATION Fieldbus, 7/8-16 UNC × M20

Connecting cable for remote version:

- Cable gland M20 × 1.5 (8 to 12 mm / 0.31 to 0.47")
- Cable entries for thread ½" NPT, G ½"

**Remote version cable specifications***Coil current cable*

- 2 × 0.75 mm<sup>2</sup> (18 AWG) PVC cable with common, braided copper shield (∅ ~ 7 mm / 0.28")
- Conductor resistance: ≤ 37 Ω/km (≤ 0.011 Ω/ft)
- Capacitance: core/core, shield grounded: ≤ 120 pF/m (≤ 37 pF/ft)
- Operating temperature:
  - Cable not permanently routed: -20 to +80 °C (-4 to +176 °F)
  - Cable permanently routed: -40 to +80 °C (-40 to +176 °F)
- Cable cross-section: max. 2.5 mm<sup>2</sup> (14 AWG)

*Electrode cable*

- 3 × 0.38 mm<sup>2</sup> (20 AWG) PVC cable with common, braided copper shield (∅ ~ 7 mm / 0.28") and individually shielded cores
- With Empty Pipe Detection (EPD): 4 × 0.38 mm<sup>2</sup> (20 AWG) PVC cable with common, braided copper shield (∅ ~ 7 mm / 0.28") and individually shielded cores
- Conductor resistance: ≤ 50 Ω/km (≤ 0.015 Ω/ft)
- Capacitance: core/shield: ≤ 420 pF/m (≤ 128 pF/ft)
- Operating temperature:
  - Cable not permanently routed: -20 to +80 °C (-4 to +176 °F)
  - Cable permanently routed: -40 to +80 °C (-40 to +176 °F)
- Cable cross-section: max. 2.5 mm<sup>2</sup> (14 AWG)

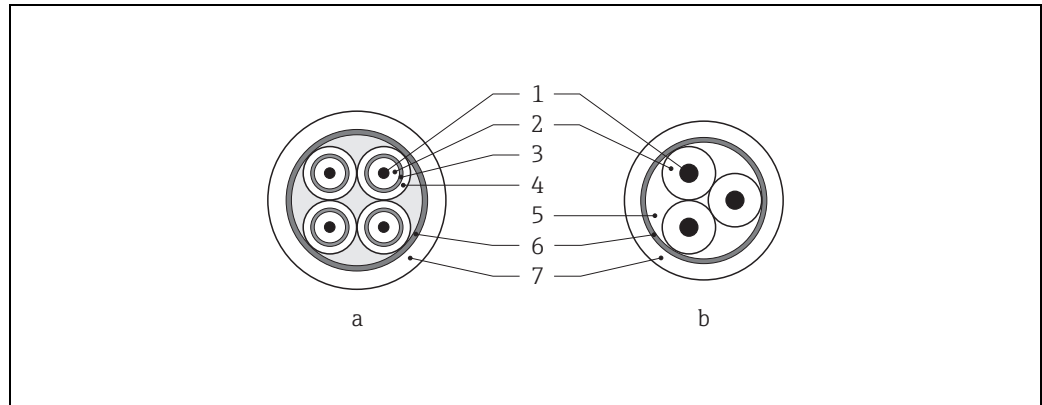

a Electrode cable  
b Coil current cable

1 Core  
2 Core insulation  
3 Core shield  
4 Core jacket  
5 Core reinforcement  
6 Cable shield  
7 Outer jacket

As an option, Endress+Hauser can also deliver reinforced connecting cables with an additional, reinforcing metal braid. We recommend such cables for the following cases:

- Directly buried cable
- Cables endangered by rodents
- Device operation which should comply with the IP 68 (NEMA 6P) standard of protection

*Operation in zones of severe electrical interference*

The measuring device complies with the general safety requirements in accordance with EN 61010-1, the EMC requirements of IEC/EN 61326 and NAMUR recommendation NE 21.



**Note!**

Grounding of the shield is by means of the ground terminals provided for the purpose inside the connection housing. Keep the stripped and twisted lengths of cable shield to the terminals as short as possible.

## Performance characteristics

### Reference operating conditions

To DIN EN 29104 and VDI/VDE 2641:

- Fluid temperature:  $+28\text{ °C} \pm 2\text{ K}$  ( $+82\text{ °F} \pm 2\text{ K}$ )
- Ambient temperature:  $+22\text{ °C} \pm 2\text{ K}$  ( $+72\text{ °F} \pm 2\text{ K}$ )
- Warm-up time: 30 minutes

Installation:

- Inlet run  $> 10 \times \text{DN}$
- Outlet run  $> 5 \times \text{DN}$
- Sensor and transmitter grounded.
- Sensor centered relative to the pipe.

### Maximum measured error

Pulse output:

- Standard:  $\pm 0.2\%$  o.r.  $\pm 2\text{ mm/s}$  ( $\pm 0.2\%$  o.r.  $\pm 0.08\text{ in/s}$ )
- With brush electrodes (Option):  $\pm 0.5\%$  o.r.  $\pm 2\text{ mm/s}$  ( $\pm 0.5\%$  o.r.  $\pm 0.08\text{ in/s}$ )  
(o.r. = of reading)

Current output:

In addition typically  $\pm 5\text{ }\mu\text{A}$



Note!

Supply-voltage fluctuations have no effect within the specified range.

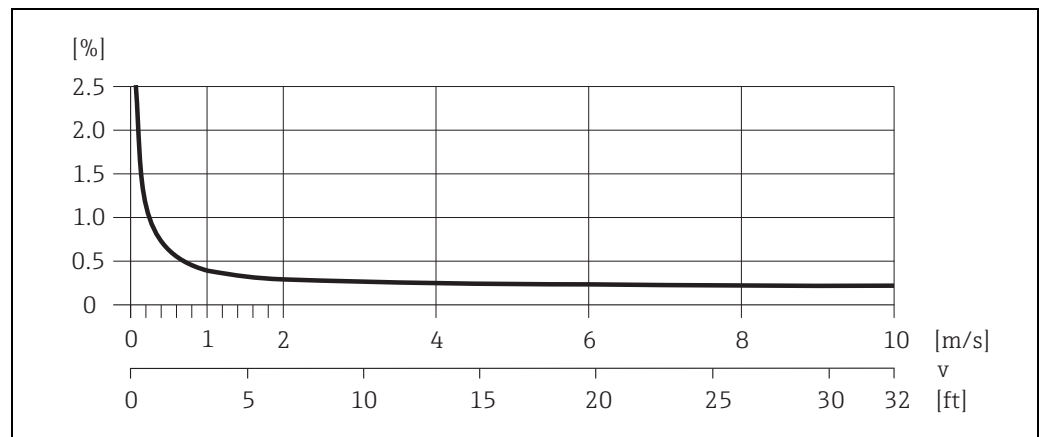

Max. measured error in % of reading

A0004456

### Conductivity

- Max. measuring error not specified
- Without temperature compensation (cell constant is a factory setting)

### Repeatability

#### Volume flow

- Standard: max.  $\pm 0.1\%$  o.r.  $\pm 0.5\text{ mm/s}$  ( $\pm 0.1\%$  o.r.  $\pm 0.02\text{ in/s}$ )
- With brush electrodes (Option): max.  $\pm 0.2\%$  o.r.  $\pm 0.5\text{ mm/s}$  ( $\pm 0.2\%$  o.r.  $\pm 0.02\text{ in/s}$ )  
(o.r. = of reading)

#### Conductivity

- Max.  $\pm 5\%$  o.r.  
(o.r. = of reading)

## Installation

### Mounting location

The accumulation of air or gas bubbles in the measuring tube could result in an increase in measuring errors. **Avoid** the following locations:

- At the highest point of a pipeline. Risk of air accumulating.
- Directly upstream from a free pipe outlet in a vertical pipeline.

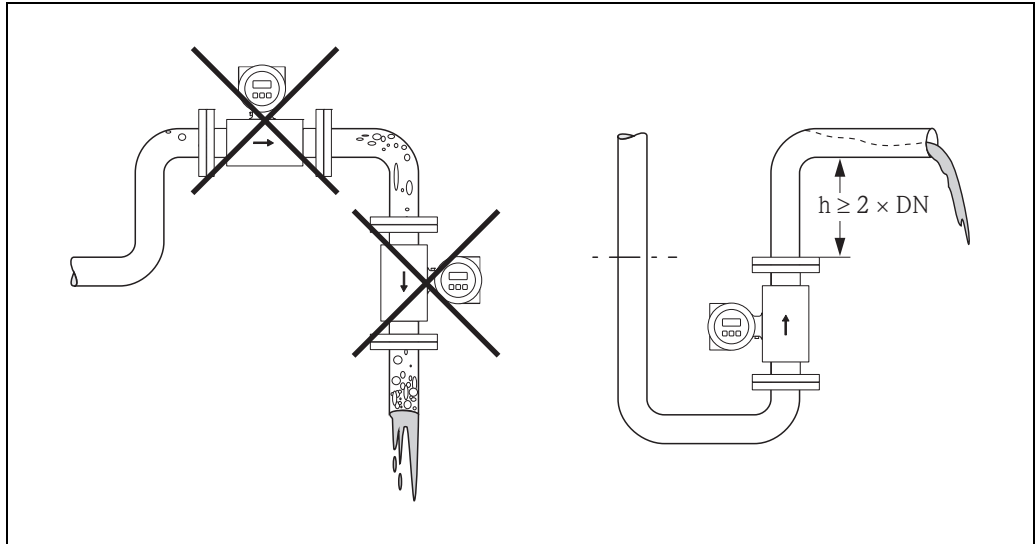

A0003202

Mounting location

### Installation of pumps

Do not install the sensor on the intake side of a pump. This precaution is to avoid low pressure and the consequent risk of damage to the lining of the measuring tube. Information on the lining's resistance to partial vacuum → 23.

It might be necessary to install pulse dampers in systems incorporating reciprocating, diaphragm or peristaltic pumps. Information on the measuring system's resistance to vibration and shock → 19.

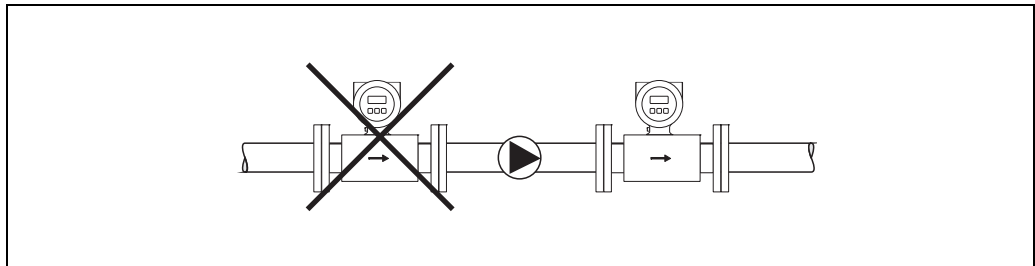

A0003203

Installation of pumps

### Partially filled pipes

Partially filled pipes with gradients necessitate a drain-type configuration. The Empty Pipe Detection function offers additional protection by detecting empty or partially filled pipes.



Note!

Risk of solids accumulating. Do not install the sensor at the lowest point in the drain. It is advisable to install a cleaning valve.

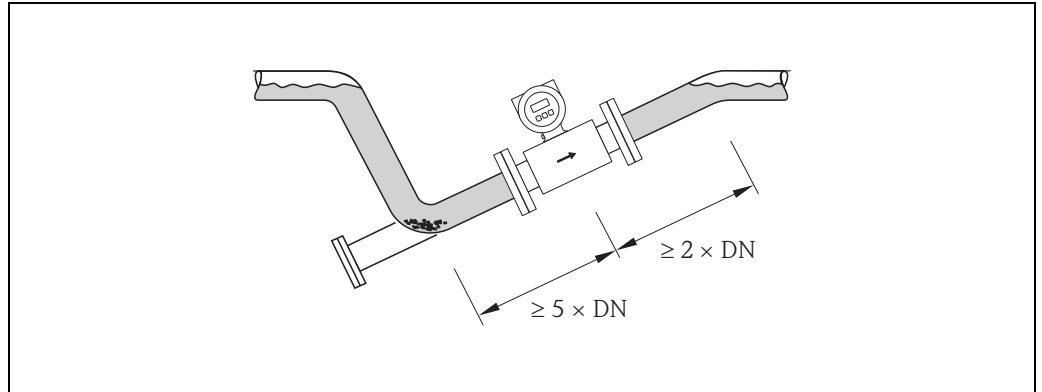

Installation with partially filled pipes

A0003204

### Down pipes

Install a siphon or a vent valve downstream of the sensor in down pipes  $h \geq 5 \text{ m}$  (16.4 ft). This precaution is to avoid low pressure and the consequent risk of damage to the lining of the measuring tube. This measure also prevents the system losing prime, which could cause air inclusions. Information on the lining's resistance to partial vacuum → 23.

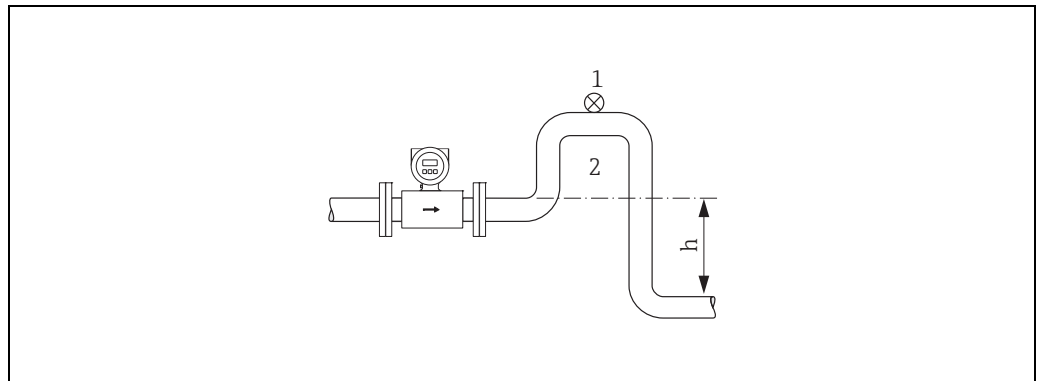

Installation measures for vertical pipes

- 1 Vent valve
- 2 Siphon
- h Vertical height of the down pipe regarding the sensor

A0008157

## Orientation

An optimum orientation position helps avoid gas and air accumulations and deposits in the measuring tube. Promag, nevertheless, supplies a range of functions and accessories for correct measuring of problematic fluids:

- Electrode Cleaning Circuit (ECC) for applications with fluids producing build-up, e.g. electrically conductive deposits → "Description of Device Functions" manual.
- Empty Pipe Detection (EPD) ensures the detection of partially filled measuring tubes, e.g. in the case of degassing fluids.

### Vertical orientation

A vertical orientation is ideal in the following cases:

- For self-emptying piping systems and when using empty pipe detection.
- For sludge containing sand or stones and where the solids cause sedimentation.

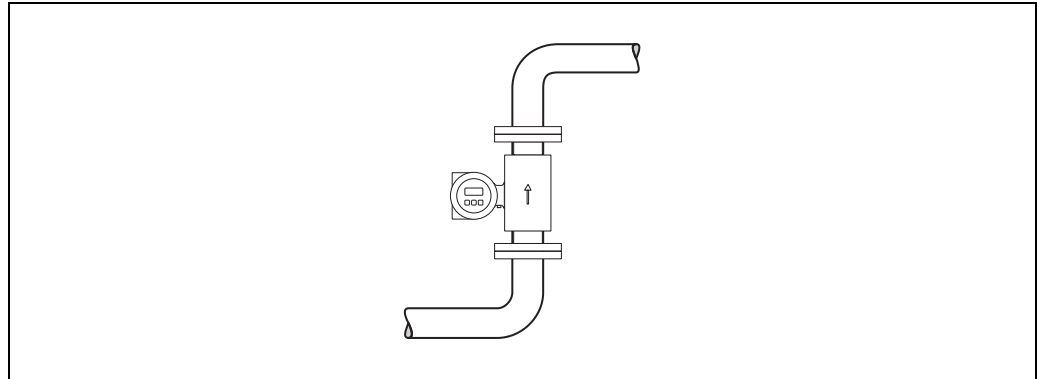

A0008158

### Horizontal orientation

The measuring electrode plane should be horizontal. This prevents brief insulation of the two electrodes by entrained air bubbles.



Note!

Empty Pipe Detection functions correctly with the measuring device installed horizontally only when the transmitter housing is facing upward (see diagram). Otherwise there is no guarantee that Empty Pipe Detection will respond if the measuring tube is only partially filled or empty.

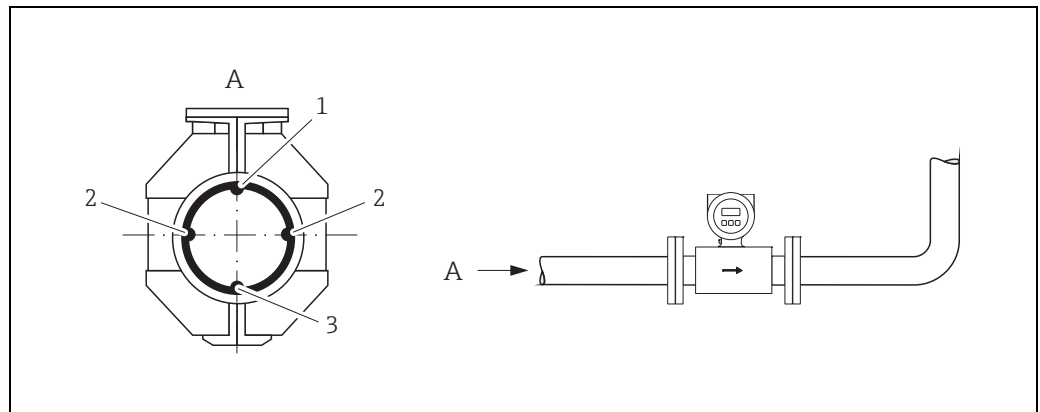

A0003207

- 1 EPD electrode for empty pipe detection (not available for "measuring electrode only" option)
- 2 Measuring electrodes for signal detection
- 3 Reference electrode for potential equalization (not available for "measuring electrode only" option)

**Inlet and outlet runs**

If possible, install the sensor well clear of fittings such as valves, T-pieces, elbows etc.

Compliance with the following requirements for the inlet and outlet runs is necessary in order to ensure measuring accuracy.

- Inlet run  $\geq 5 \times DN$
- Outlet run  $\geq 2 \times DN$

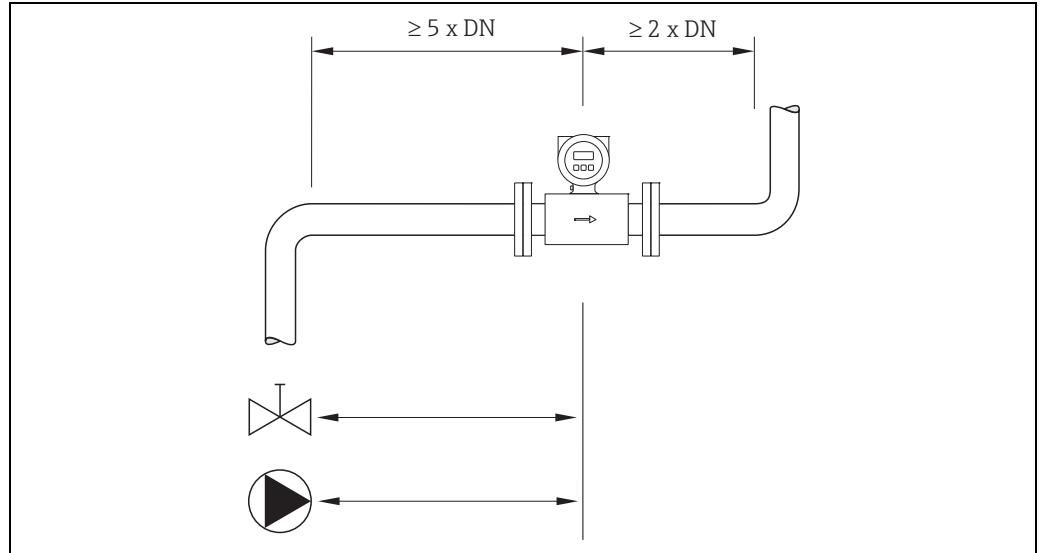

A0003210

**Adapters**

Suitable adapters to DIN EN 545 (double-flange reducers) can be used to install the sensor in larger-diameter pipes. The resultant increase in the rate of flow improves measuring accuracy with very slow-moving fluids. The nomogram shown here can be used to calculate the pressure loss caused by cross-section reduction.



Note!

The nomogram applies to fluids of viscosity similar to water.

1. Calculate the ratio of the diameters  $d/D$ .
2. From the nomogram, read off the pressure loss as a function of fluid velocity (*downstream* from the reduction) and the  $d/D$  ratio.

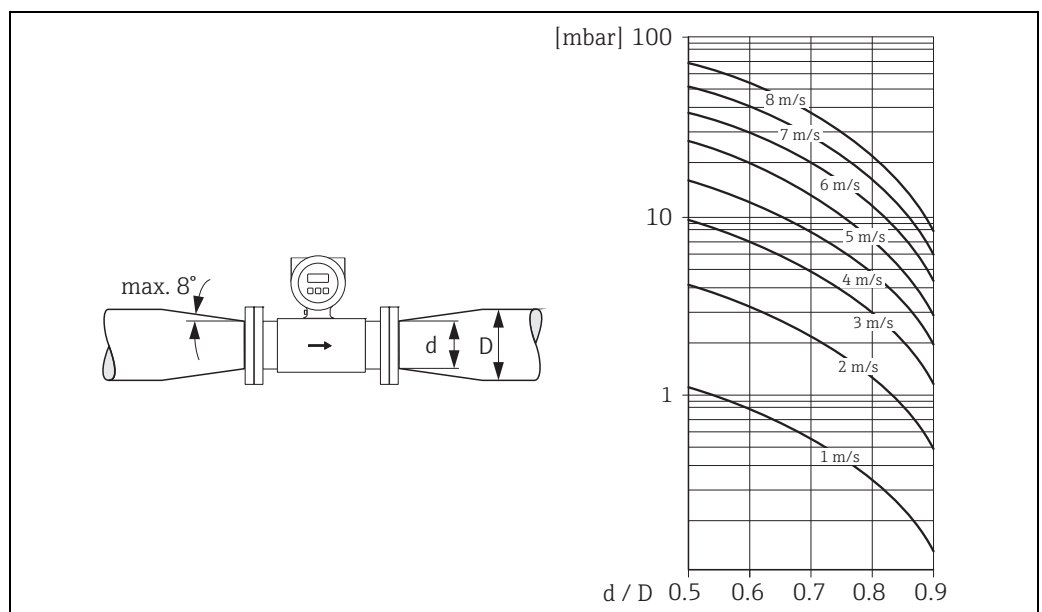

A0003213

Pressure loss due to adapters (for pressure losses in US units, please contact Endress+Hauser)

**Length of connecting cable**

In order to ensure measuring accuracy, comply with the following instructions when installing the remote version:

- Secure the cable run or route the cable in an armored conduit. Movement of the cable can falsify the measuring signal, particularly if the fluid conductivity is low.
- Route the cable well clear of electrical machines and switching elements.
- Ensure potential equalization between sensor and transmitter, if necessary.
- The permissible cable length  $L_{\max}$  depends on the fluid conductivity (see Figure).
- The maximum connecting cable length is 10 m (32.8 ft) when empty pipe detection (EPD) is switched on.

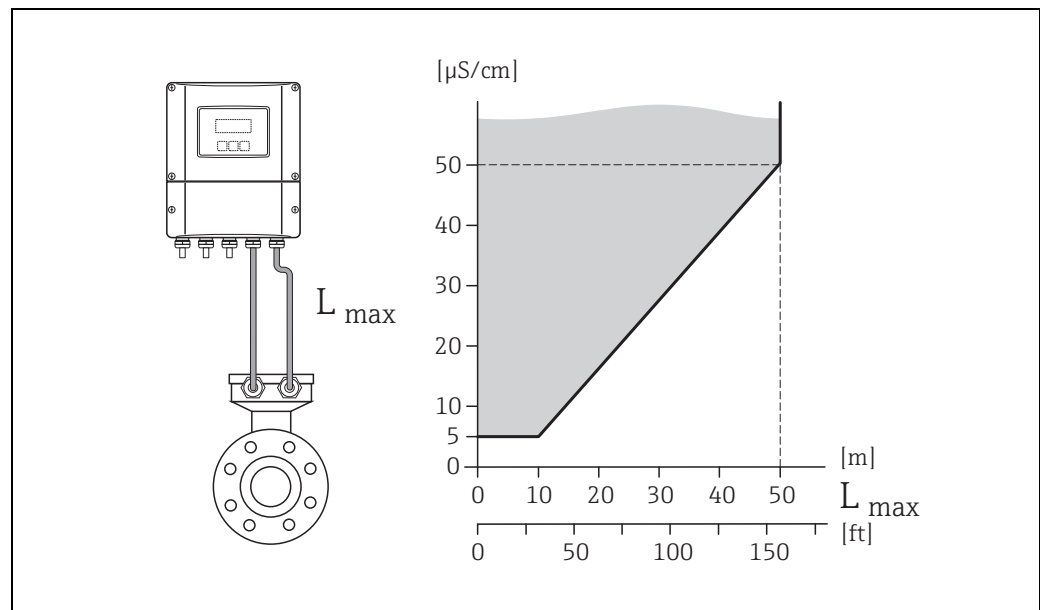

A0006116

Permitted lengths for connecting cable in remote version, as a function of the conductivity of the fluid

Gray shaded area = permissible area

$L_{\max}$  = Length of connecting cable

**Foundations, supports**

If the nominal diameter is  $DN \geq 350$  (14"), mount the sensor on a foundation of adequate load-bearing strength.

Note!

Risk of damage.

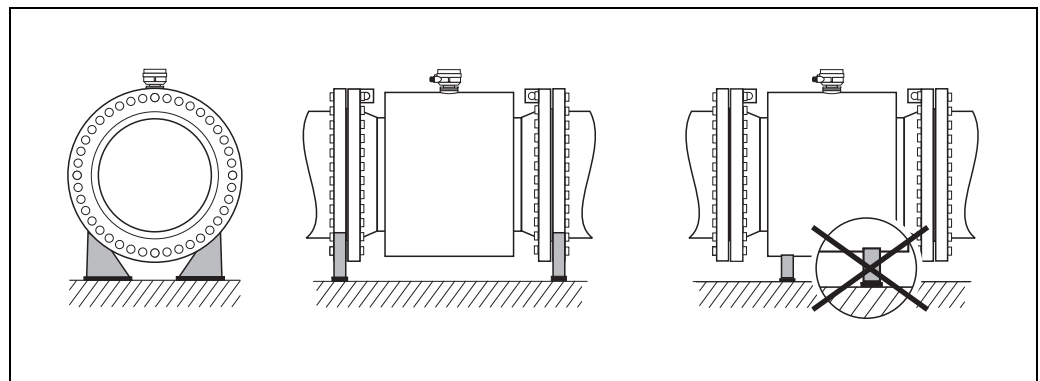

Do not support the weight of the sensor on the metal casing: the casing would buckle and damage the internal magnetic coils.



A0003209

Correct support for large nominal diameters ( $DN \geq 350 / 14''$ )

## Environment

|  |  |
|--|--|
| <b>Ambient temperature range</b>           | <p>Transmitter:</p> <ul style="list-style-type: none"> <li>■ Standard:           <ul style="list-style-type: none"> <li>– Compact version: <math>-20</math> to <math>+50</math> °C (<math>-4</math> to <math>+122</math> °F)</li> <li>– Remote version: <math>-20</math> to <math>+60</math> °C (<math>-4</math> to <math>+140</math> °F)</li> </ul> </li> <li>■ Optional:           <ul style="list-style-type: none"> <li>– Compact version: <math>-40</math> to <math>+50</math> °C (<math>-40</math> to <math>+122</math> °F)</li> <li>– Remote version: <math>-40</math> to <math>+60</math> °C (<math>-40</math> to <math>+140</math> °F)</li> </ul> </li> </ul> <p> Note!<br/>At ambient temperatures below <math>-20</math> °C (<math>-4</math> °F), the readability of the display may be impaired.</p> <p>Sensor:</p> <ul style="list-style-type: none"> <li>■ Flange material carbon steel: <math>-10</math> to <math>+60</math> °C (<math>+14</math> to <math>+140</math> °F)</li> <li>■ Flange material stainless steel: <math>-40</math> to <math>+60</math> °C (<math>-40</math> to <math>+140</math> °F)</li> </ul> <p> Note!<br/>Do not exceed the min. and max. temperatures for the lining of the measuring tube (→ "Medium temperature range").</p> <p>Note the following points:</p> <ul style="list-style-type: none"> <li>■ Install the device at a shady location. Avoid direct sunlight, particularly in warm climatic regions.</li> <li>■ If both fluid and ambient temperatures are high, install the transmitter at a remote location from the sensor (→ "Medium temperature range").</li> </ul> |
| <b>Storage temperature</b>                 | The storage temperature corresponds to the operating temperature range of the transmitter and sensor.  |
| <b>Degree of protection</b>                | <ul style="list-style-type: none"> <li>■ Standard: IP 67 (NEMA 4X) for transmitter and sensor</li> <li>■ Optional: IP 68 (NEMA 6P) for remote version of Promag S sensor</li> <li>■ For information regarding applications where the device is buried directly in the soil or is installed in a flooded wastewater basin please contact your local Endress+Hauser Sales Center.</li> </ul>   |
| <b>Shock and vibration resistance</b>      | Acceleration up to 2 g by analogy with IEC 600 68-2-6<br>(High temperature version: no data available)   |
| <b>Electromagnetic compatibility (EMC)</b> | According to IEC/EN 61326 and NAMUR recommendation NE 21   |

## Process

### Medium temperature range

The permitted temperature depends on the lining of the measuring tube:

- 0 to +60 °C (+32 to +140 °F) for natural rubber (DN 65 to 600 / 2½ to 24")
- 0 to +80 °C (+32 to +176 °F) for hard rubber (DN 65 to 600 / 2½ to 24")
- -20 to +50 °C (-4 to +122 °F) for polyurethane (DN 25 to 600 / 1 to 24")
- -20 to +180 °C (-4 to +356 °F) for PFA (DN 25 to 200 / 1 to 8"), restrictions → see diagrams
- -40 to +130 °C (-40 to +266 °F) for PTFE (DN 15 to 600 / ½ to 24"), restrictions → see diagrams

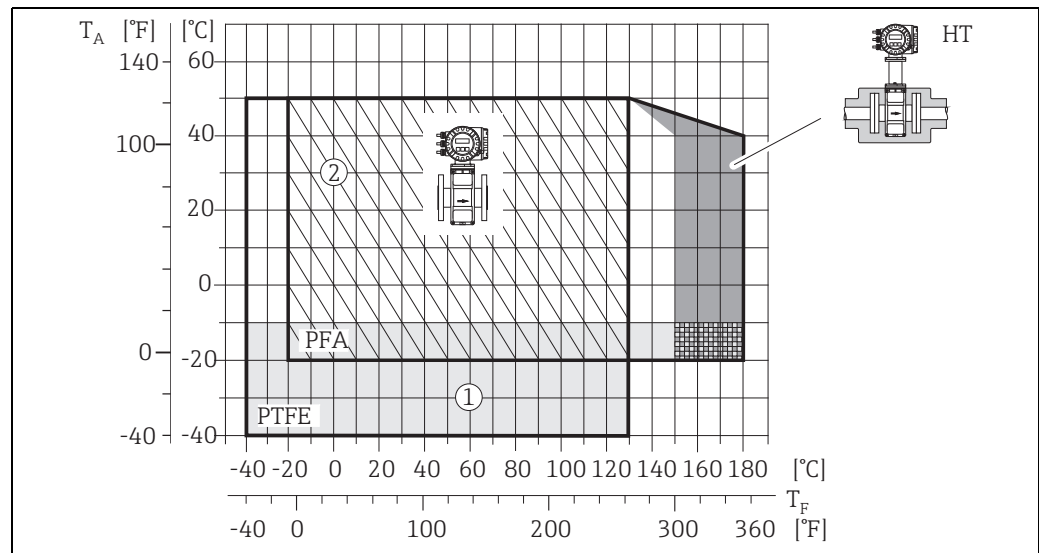

A0006119

Promag S compact versions (with PFA or PTFE lining)

$T_A$  Ambient temperature

$T_F$  Fluid temperature

HT High temperature version with insulation

1 Gray shaded area → temperature range from -10 to -40 °C (-14 to -40 °F) applies only to stainless steel flanges

2 HE + IP 68 to 130 °C (266 °F) only

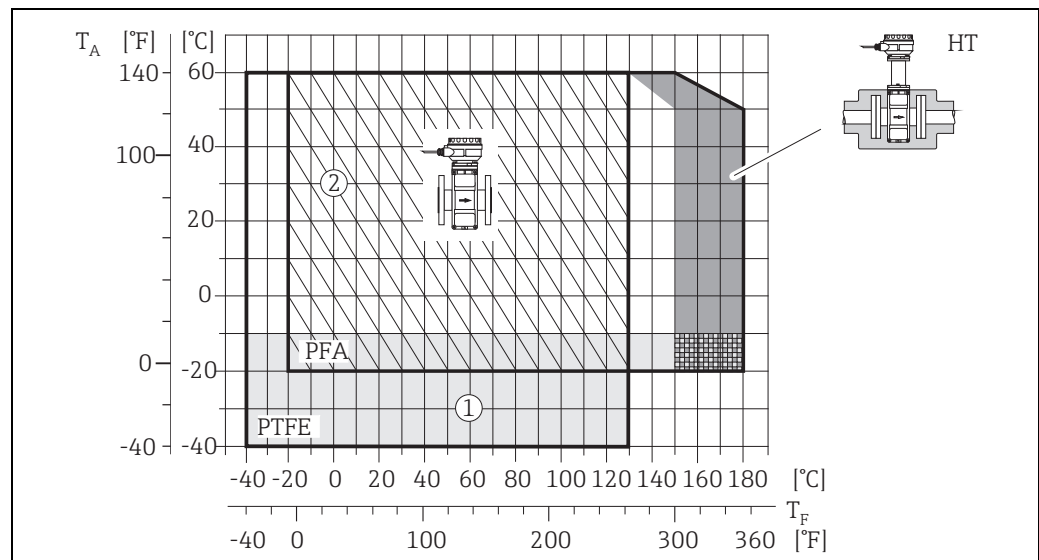

A0002671

Promag S remote versions (with PFA or PTFE lining)

$T_A$  Ambient temperature

$T_F$  Fluid temperature

HT High temperature version with insulation

1 Gray shaded area → temperature range from -10 to -40 °C (-14 to -40 °F) applies only to stainless steel flanges

2 HE + IP 68 to 130 °C (266 °F) only

**Conductivity**



Minimum conductivity:

- $\geq 5 \mu\text{S/cm}$  for all liquids (incl. demineralized water)

Note!

In the remote version, the required minimum conductivity is also influenced by the length of the cable  
 → 18.

**Pressure-temperature ratings**

The following diagrams contain material load curves (reference curves) for various process connections relating to the fluid temperature. But the maximal permissible fluid temperature always depends on the lining material of the sensor and/or the sealing material.

**Process connection: flange according to EN 1092-1 (DIN 2501)**

Process connection material: S235JRG2, S235JR+N, P250GH, P245GH, E250C, A105

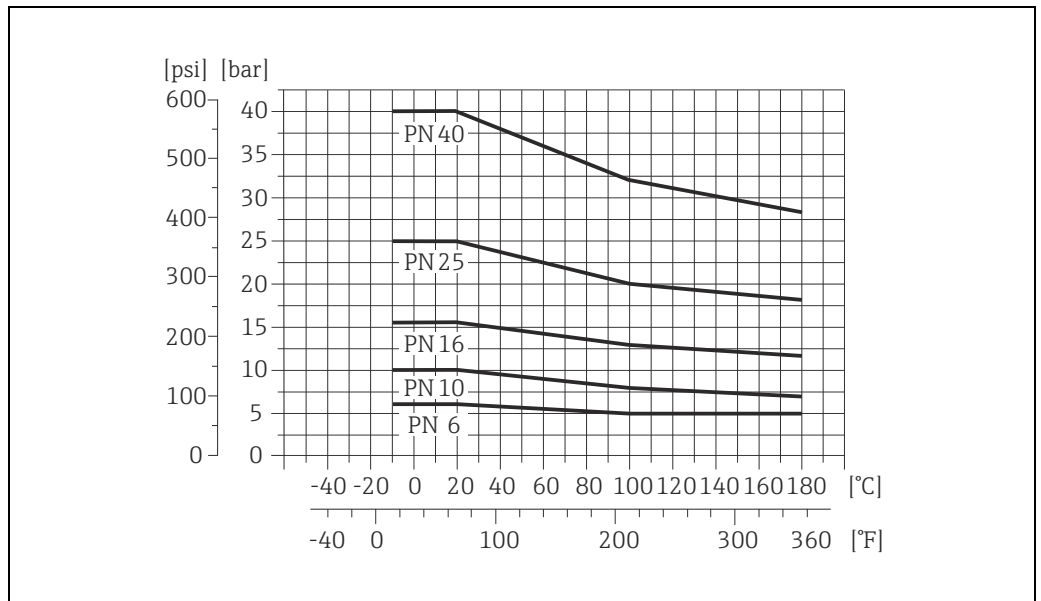

A0021188-EN

**Process connection: flange according to EN 1092-1 (DIN 2501)**

Process connection material: 1.4571, F316L

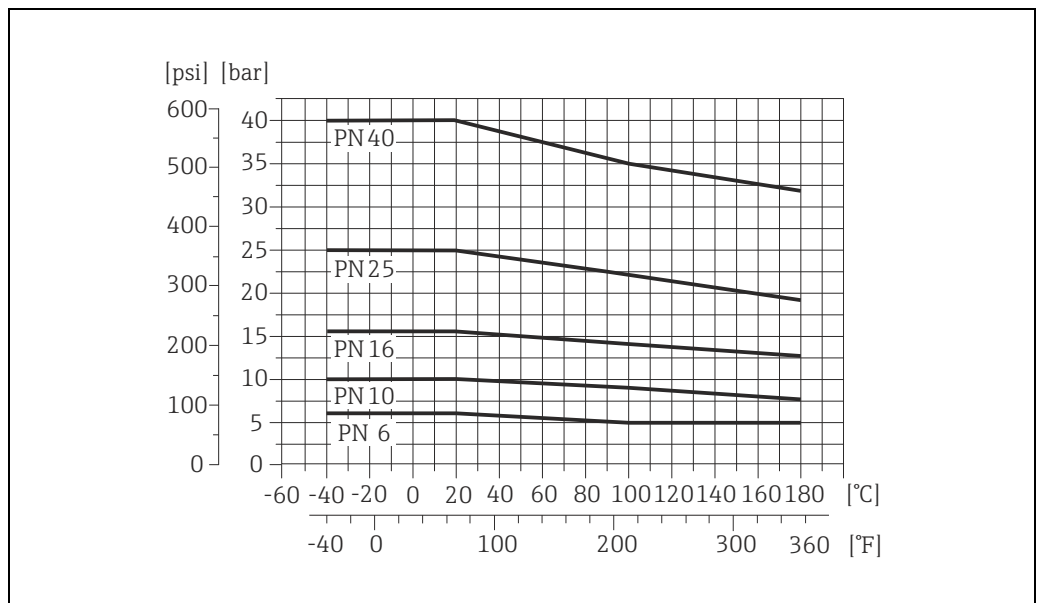

A0021184-EN

**Process connection: flange according to ASME B16.5**

Process connection material: A105

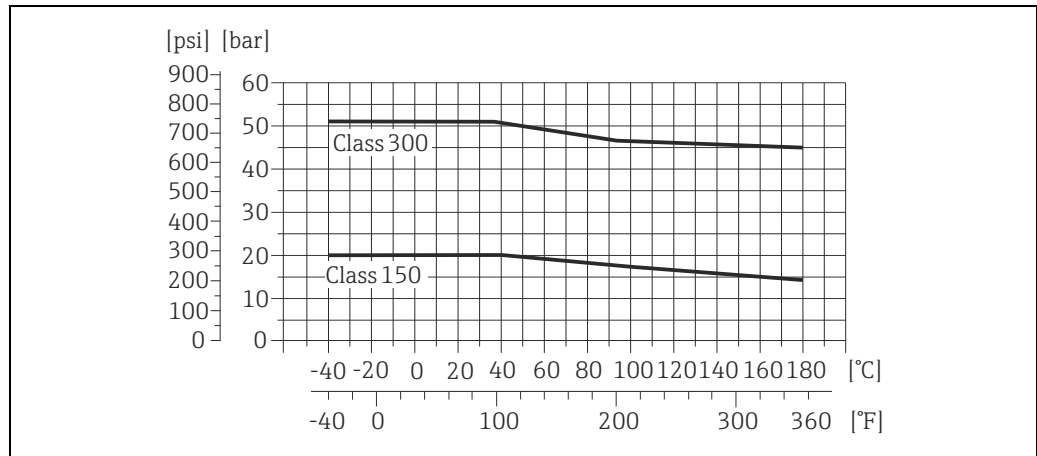

A0021182-EN

**Process connection: flange according to ASME B16.5**

Process connection material: F316L

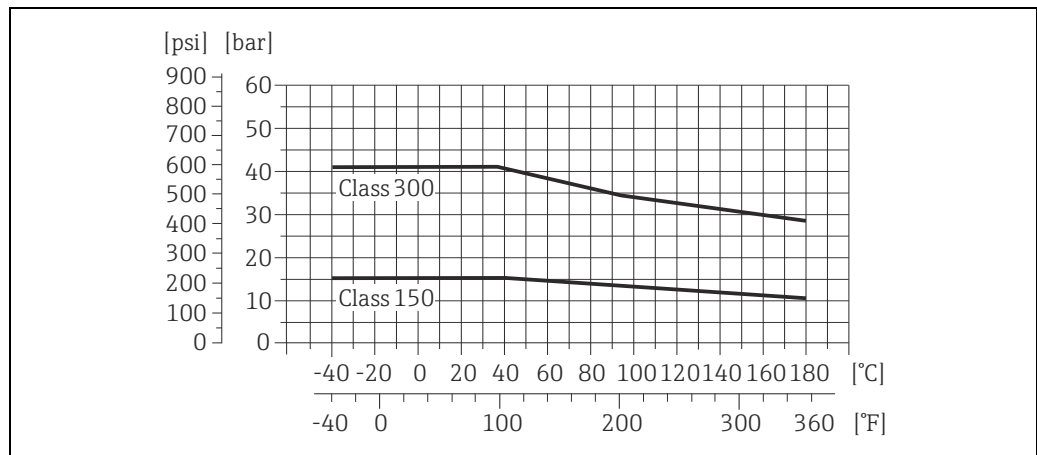

A0021185-EN

**Process connection: flange according to JIS B2220**

Process connection material: A105, A350 LF2, F316L

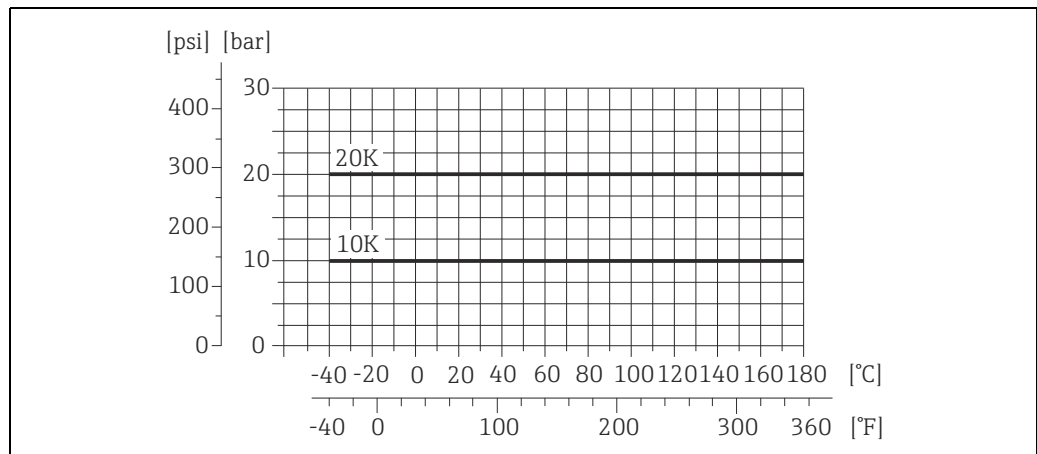

A0021183-EN

**Process connection: flange according to AS 2129 Table E or AS 4087 PN 16**

Process connection material: A105, P235GH, P265GH, S235JRG2

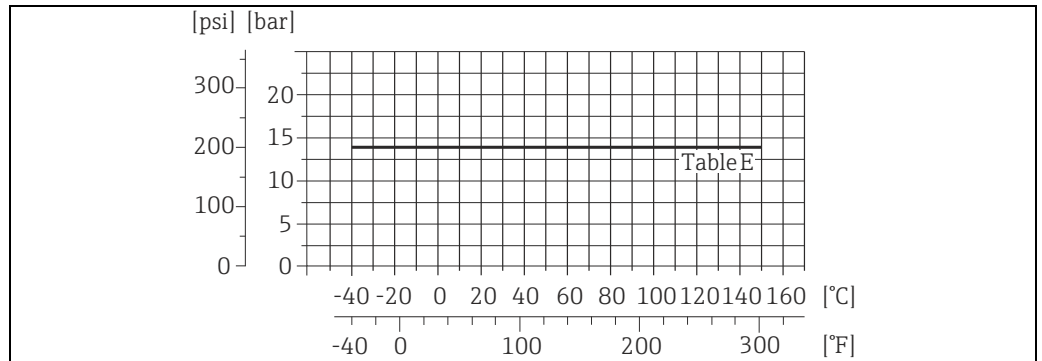

A0021189-EN

**Process connection: flange according to AS 2129 Table E or AS 4087 PN 16**

Process connection material: A105, P265GH, S275JR

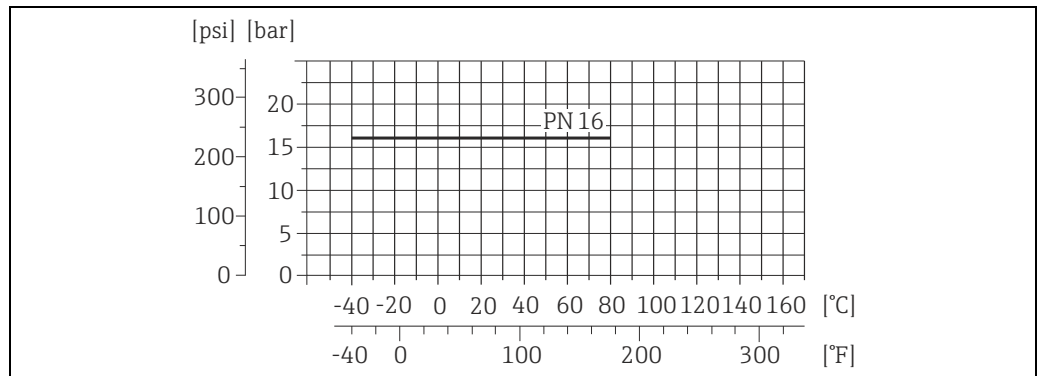

A0023077-EN

**Medium pressure range (nominal pressure)**

- EN 1092-1 (DIN 2501): PN 10 (DN 200 to 600 / 8 to 24"), PN 16 (DN 65 to 600 / 2½ to 24"), PN 25 (DN 200 to 600 / 8 to 24"), PN 40 (DN 15 to 150 / ½ to 6")
- ASME B16.5: Class 150 (DN ½ to 24"), Class 300 (DN ½ to 6")
- JIS B2220: 10K (DN 50 to 600 / 2 to 24"), 20K (DN 15 to 600 / ½ to 24")
- AS 2129: Table E (DN 25 / 1", DN 50 / 2")
- AS 4087: PN 16 (DN 50 / 2")

**Pressure tightness (lining)**

**Pressure tightness in SI units [mbar]**

| Promag S<br>Nominal<br>diameter<br>[mm] | Measuring tube<br>lining | Resistance of measuring tube lining to partial vacuum (SI units)<br>Limit values for abs. pressure [mbar] at various fluid temperatures |       |       |        |        |        |        |
|---|--------------------------|---|-------|-------|--------|--------|--------|--------|
|   |                          | 25 °C   | 50 °C | 80 °C | 100 °C | 130 °C | 150 °C | 180 °C |
| 25 to 600                               | Polyurethane             | 0   | 0     | -     | -      | -      | -      | -      |
| 65 to 600                               | Natural rubber           | 0   | 0     | -     | -      | -      | -      | -      |
| 65 to 600                               | Hard rubber              | 0   | 0     | 0     | -      | -      | -      | -      |

| Promag S<br>Nominal<br>diameter<br>[mm] | Measuring tube<br>lining | Resistance of measuring tube lining to partial vacuum (SI units)<br>Limit values for abs. pressure [mbar] at various fluid temperatures |       |        |        |        |        |
|---|--------------------------|---|-------|--------|--------|--------|--------|
|   |                          | 25 °C   | 80 °C | 100 °C | 130 °C | 150 °C | 180 °C |
| 15                                      | PTFE                     | 0   | 0     | 0      | 100    | -      | -      |
| 25                                      | PTFE / PFA               | 0/0   | 0/0   | 0/0    | 100/0  | -/0    | -/0    |

|                           |            |                                  |     |       |       |     |     |
|---------------------------|------------|----------------------------------|-----|-------|-------|-----|-----|
| 32                        | PTFE / PFA | 0/0                              | 0/0 | 0/0   | 100/0 | -/0 | -/0 |
| 40                        | PTFE / PFA | 0/0                              | 0/0 | 0/0   | 100/0 | -/0 | -/0 |
| 50                        | PTFE / PFA | 0/0                              | 0/0 | 0/0   | 100/0 | -/0 | -/0 |
| 65                        | PTFE / PFA | 0/0                              | *   | 40/0  | 130/0 | -/0 | -/0 |
| 80                        | PTFE / PFA | 0/0                              | *   | 40/0  | 130/0 | -/0 | -/0 |
| 100                       | PTFE / PFA | 0/0                              | *   | 135/0 | 170/0 | -/0 | -/0 |
| 125                       | PTFE / PFA | 135/0                            | *   | 240/0 | 385/0 | -/0 | -/0 |
| 150                       | PTFE / PFA | 135/0                            | *   | 240/0 | 385/0 | -/0 | -/0 |
| 200                       | PTFE / PFA | 200/0                            | *   | 290/0 | 410/0 | -/0 | -/0 |
| 250                       | PTFE       | 330                              | *   | 400   | 530   | -   | -   |
| 300                       | PTFE       | 400                              | *   | 500   | 630   | -   | -   |
| 350                       | PTFE       | 470                              | *   | 600   | 730   | -   | -   |
| 400                       | PTFE       | 540                              | *   | 670   | 800   | -   | -   |
| 450                       | PTFE       | Partial vacuum is impermissible! |     |       |       |     |     |
| 500                       | PTFE       |                                  |     |       |       |     |     |
| 600                       | PTFE       |                                  |     |       |       |     |     |
| * No value can be quoted. |            |                                  |     |       |       |     |     |

#### Pressure tightness in US units [psi = pounds/inch<sup>2</sup>]

| Promag S<br>Nominal<br>diameter<br>[inch] | Measuring tube<br>lining | Resistance of measuring tube lining to partial vacuum (US units)<br>Limit values for abs. pressure [psi] at various fluid temperatures |        |        |        |        |        |        |
|---|--------------------------|--|--------|--------|--------|--------|--------|--------|
|   |                          | 77 °F  | 122 °F | 176 °F | 212 °F | 266 °F | 302 °F | 356 °F |
| 1 to 24"                                  | Polyurethane             | 0  | 0      | -      | -      | -      | -      | -      |
| 3 to 24"                                  | Natural rubber           | 0  | 0      | -      | -      | -      | -      | -      |
| 3 to 24"                                  | Hard rubber              | 0  | 0      | 0      | -      | -      | -      | -      |

| Promag S<br>Nominal<br>diameter<br>[inch] | Measuring tube<br>lining | Resistance of measuring tube lining to partial vacuum (US units)<br>Limit values for abs. pressure [psi] at various fluid temperatures |        |        |        |        |        |
|---|--------------------------|--|--------|--------|--------|--------|--------|
|   |                          | 77 °F  | 176 °F | 212 °F | 266 °F | 302 °F | 356 °F |
| ½"  | PTFE                     | 0  | 0      | 0      | 1.5    | -      | -      |
| 1"  | PTFE / PFA               | 0/0  | 0/0    | 0/0    | 1.5/0  | -/0    | -/0    |
| -   | PTFE / PFA               | 0/0  | 0/0    | 0/0    | 1.5/0  | -/0    | -/0    |
| 1½"                                       | PTFE / PFA               | 0/0  | 0/0    | 0/0    | 1.5/0  | -/0    | -/0    |
| 2"  | PTFE / PFA               | 0/0  | 0/0    | 0/0    | 1.5/0  | -/0    | -/0    |
| -   | PTFE / PFA               | 0/0  | *      | 0.6/0  | 1.9/0  | -/0    | -/0    |
| 3"  | PTFE / PFA               | 0/0  | *      | 0.6/0  | 1.9/0  | -/0    | -/0    |
| 4"  | PTFE / PFA               | 0/0  | *      | 2.0/0  | 2.5/0  | -/0    | -/0    |
| -   | PTFE / PFA               | 2.0/0  | *      | 3.5/0  | 5.6/0  | -/0    | -/0    |
| 6"  | PTFE / PFA               | 2.0/0  | *      | 3.5/0  | 5.6/0  | -/0    | -/0    |
| 8"  | PTFE / PFA               | 2.9/0  | *      | 4.2/0  | 5.9/0  | -/0    | -/0    |
| 10"                                       | PTFE                     | 4.8  | *      | 5.8    | 7.7    | -      | -      |
| 12"                                       | PTFE                     | 5.8  | *      | 7.3    | 9.1    | -      | -      |
| 14"                                       | PTFE                     | 6.8  | *      | 8.7    | 10.6   | -      | -      |
| 16"                                       | PTFE                     | 7.8  | *      | 9.7    | 11.6   | -      | -      |
| 18"                                       | PTFE                     | Partial vacuum is impermissible!   |        |        |        |        |        |
| 20"                                       | PTFE                     |  |        |        |        |        |        |
| 24"                                       | PTFE                     |  |        |        |        |        |        |
| * No value can be quoted.                 |                          |  |        |        |        |        |        |

**Limiting flow**

The diameter of the pipe and the flow rate determine the nominal diameter of the sensor. The optimum flow velocity is between 2 and 3 m/s (6 to 10 ft/s). The flow velocity (v), moreover, has to be matched to the physical properties of the fluid:

- v < 2 m/s (6 ft/s): for abrasive fluids where solids do not cause sedimentation (e.g. lime milk)
- v > 2 m/s (6 ft/s): for fluids producing build-up (e.g. wastewater sludge)
- v > 2 m/s (6 ft/s): for abrasive sludge with a high sand or stone content and where the solids easily cause sedimentation (e.g. ore slurry)



**Note!**

Flow velocity can be increased, if necessary, by reducing the nominal diameter of the sensor through the use of adapters → 17.

| Flow rate characteristic values - Promag S (SI units) |  |                                   |                              |                                    |
|---|--|-----------------------------------|------------------------------|------------------------------------|
| Nominal diameter<br>[mm]                              | Recommended flow rate<br>min./max. full scale value<br>(v ≈ 0.3 or 10 m/s) | Factory settings                  |                              |                                    |
|   |  | Full scale value<br>(v ≈ 2.5 m/s) | Pulse value<br>(≈ 2 pulse/s) | Low flow cut off<br>(v ≈ 0.04 m/s) |
| 15  | 4 to 100 dm <sup>3</sup> /min  | 25 dm <sup>3</sup> /min           | 0.20 dm <sup>3</sup>         | 0.5 dm <sup>3</sup> /min           |
| 25  | 9 to 300 dm <sup>3</sup> /min  | 75 dm <sup>3</sup> /min           | 0.50 dm <sup>3</sup>         | 1 dm <sup>3</sup> /min             |
| 32  | 15 to 500 dm <sup>3</sup> /min   | 125 dm <sup>3</sup> /min          | 1.00 dm <sup>3</sup>         | 2 dm <sup>3</sup> /min             |
| 40  | 25 to 700 dm <sup>3</sup> /min   | 200 dm <sup>3</sup> /min          | 1.50 dm <sup>3</sup>         | 3 dm <sup>3</sup> /min             |
| 50  | 35 to 1100 dm <sup>3</sup> /min  | 300 dm <sup>3</sup> /min          | 2.50 dm <sup>3</sup>         | 5 dm <sup>3</sup> /min             |
| 65  | 60 to 2000 dm <sup>3</sup> /min  | 500 dm <sup>3</sup> /min          | 5.00 dm <sup>3</sup>         | 8 dm <sup>3</sup> /min             |
| 80  | 90 to 3000 dm <sup>3</sup> /min  | 750 dm <sup>3</sup> /min          | 5.00 dm <sup>3</sup>         | 12 dm <sup>3</sup> /min            |
| 100   | 145 to 4700 dm <sup>3</sup> /min   | 1200 dm <sup>3</sup> /min         | 10.00 dm <sup>3</sup>        | 20 dm <sup>3</sup> /min            |
| 125   | 220 to 7500 dm <sup>3</sup> /min   | 1850 dm <sup>3</sup> /min         | 15.00 dm <sup>3</sup>        | 30 dm <sup>3</sup> /min            |
| 150   | 20 to 600 m <sup>3</sup> /h  | 150 m <sup>3</sup> /h             | 0.025 m <sup>3</sup>         | 2.5 m <sup>3</sup> /h              |
| 200   | 35 to 1100 m <sup>3</sup> /h   | 300 m <sup>3</sup> /h             | 0.05 m <sup>3</sup>          | 5.0 m <sup>3</sup> /h              |
| 250   | 55 to 1700 m <sup>3</sup> /h   | 500 m <sup>3</sup> /h             | 0.05 m <sup>3</sup>          | 7.5 m <sup>3</sup> /h              |
| 300   | 80 to 2400 m <sup>3</sup> /h   | 750 m <sup>3</sup> /h             | 0.10 m <sup>3</sup>          | 10 m <sup>3</sup> /h               |
| 350   | 110 to 3300 m <sup>3</sup> /h  | 1000 m <sup>3</sup> /h            | 0.10 m <sup>3</sup>          | 15 m <sup>3</sup> /h               |
| 400   | 140 to 4200 m <sup>3</sup> /h  | 1200 m <sup>3</sup> /h            | 0.15 m <sup>3</sup>          | 20 m <sup>3</sup> /h               |
| 450   | 180 to 5400 m <sup>3</sup> /h  | 1500 m <sup>3</sup> /h            | 0.25 m <sup>3</sup>          | 25 m <sup>3</sup> /h               |
| 500   | 220 to 6600 m <sup>3</sup> /h  | 2000 m <sup>3</sup> /h            | 0.25 m <sup>3</sup>          | 30 m <sup>3</sup> /h               |
| 600   | 310 to 9600 m <sup>3</sup> /h  | 2500 m <sup>3</sup> /h            | 0.30 m <sup>3</sup>          | 40 m <sup>3</sup> /h               |

| Flow rate characteristic values - Promag S (US units) |  |   |                                       |   |
|---|--|---|---------------------------------------|---|
| Nominal diameter<br>[inch]                            | Recommended flow rate<br>min./max. full scale value<br>( $v \approx 1.0$ or 33 ft/s) | Factory settings                            |                                       |   |
|   |  | Full scale value<br>( $v \approx 8.2$ ft/s) | Pulse value<br>( $\approx 2$ pulse/s) | Low flow cut off<br>( $v \approx 0.1$ ft/s) |
| ½"  | 1.0 to 27 gal/min  | 6 gal/min                                   | 0.05 gal                              | 0.10 gal/min                                |
| 1"  | 2.5 to 80 gal/min  | 18 gal/min                                  | 0.20 gal                              | 0.25 gal/min                                |
| 1¼"   | 4 to 130 gal/min   | 30 gal/min                                  | 0.20 gal                              | 0.50 gal/min                                |
| 1½"   | 7 to 190 gal/min   | 50 gal/min                                  | 0.50 gal                              | 0.75 gal/min                                |
| 2"  | 10 to 300 gal/min  | 75 gal/min                                  | 0.50 gal                              | 1.25 gal/min                                |
| 2½"   | 16 to 500 gal/min  | 130 gal/min                                 | 1 gal                                 | 2.0 gal/min                                 |
| 3"  | 24 to 800 gal/min  | 200 gal/min                                 | 2 gal                                 | 2.5 gal/min                                 |
| 4"  | 40 to 1250 gal/min   | 300 gal/min                                 | 2 gal                                 | 4.0 gal/min                                 |
| 5"  | 60 to 1950 gal/min   | 450 gal/min                                 | 5 gal                                 | 7.0 gal/min                                 |
| 6"  | 90 to 2650 gal/min   | 600 gal/min                                 | 5 gal                                 | 12 gal/min                                  |
| 8"  | 155 to 4850 gal/min  | 1200 gal/min                                | 10 gal                                | 15 gal/min                                  |
| 10"   | 250 to 7500 gal/min  | 1500 gal/min                                | 15 gal                                | 30 gal/min                                  |
| 12"   | 350 to 10600 gal/min   | 2400 gal/min                                | 25 gal                                | 45 gal/min                                  |
| 14"   | 500 to 15000 gal/min   | 3600 gal/min                                | 30 gal                                | 60 gal/min                                  |
| 16"   | 600 to 19000 gal/min   | 4800 gal/min                                | 50 gal                                | 60 gal/min                                  |
| 18"   | 800 to 24000 gal/min   | 6000 gal/min                                | 50 gal                                | 90 gal/min                                  |
| 20"   | 1000 to 30000 gal/min  | 7500 gal/min                                | 75 gal                                | 120 gal/min                                 |
| 24"   | 1400 to 44 000 gal/min   | 10500 gal/min                               | 100 gal                               | 180 gal/min                                 |

### Pressure loss

- No pressure loss if the sensor is installed in a pipe of the same nominal diameter.
- Pressure losses for configurations incorporating adapters according to DIN EN 545 →  17.

### Vibrations



Secure and fix both the piping and the sensor if the vibrations are severe.

Note!

It is advisable to install sensor and transmitter separately if vibration is excessively severe. Information on the permitted resistance to vibration and shock →  19.

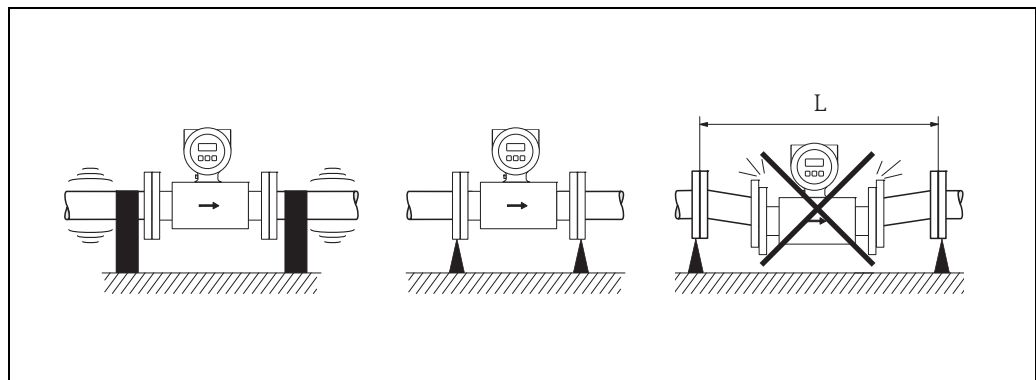

Measures to prevent vibration of the measuring device ( $L > 10$  m / 33 ft)

A0003208

## Mechanical construction

### Design, dimensions

### Transmitter wall-mount housing (non hazardous area and II3G / zone 2)

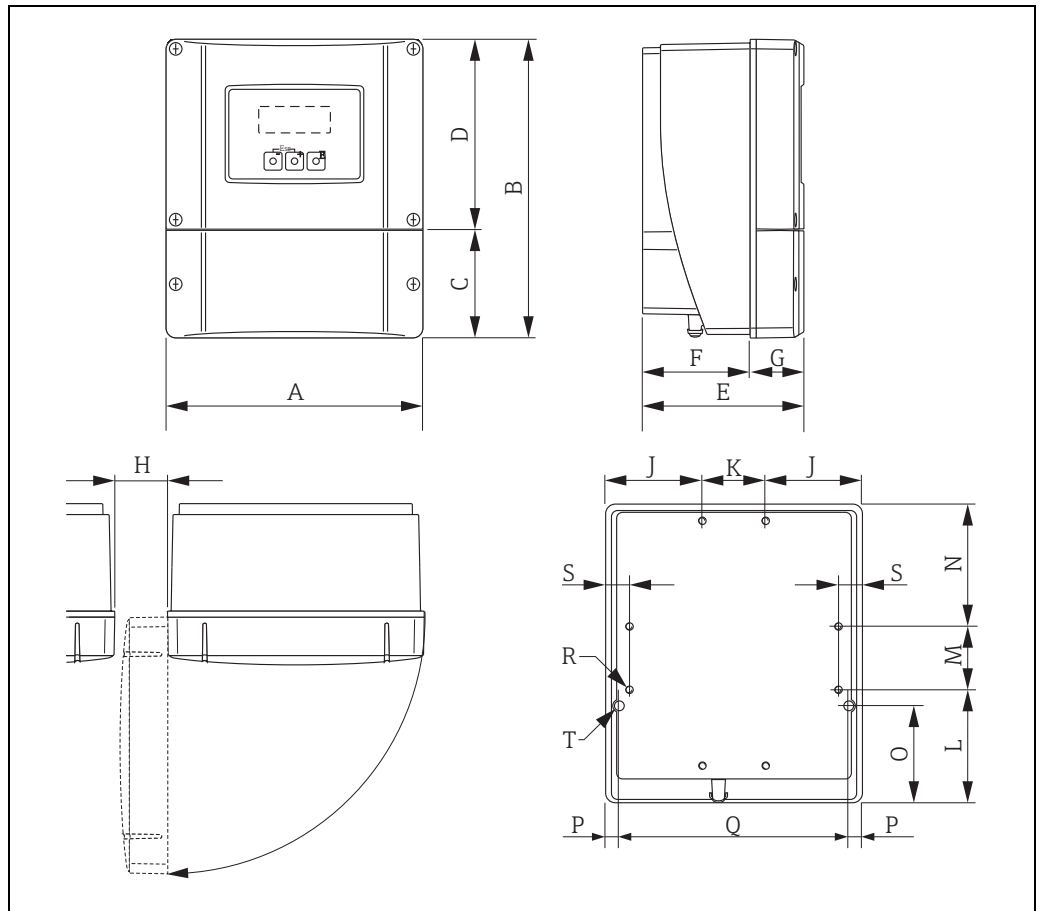

A0001150

#### Dimensions (SI units)

| A   | B   | C    | D     | E    | F   | G      | H    | J               | K  |
|-----|-----|------|-------|------|-----|--------|------|-----------------|----|
| 215 | 250 | 90.5 | 159.5 | 135  | 90  | 45     | > 50 | 81              | 53 |
| L   | M   | N    | O     | P    | Q   | R      | S    | T <sup>1)</sup> |    |
| 95  | 53  | 102  | 81.5  | 11.5 | 192 | 8 × M5 | 20   | 2 × Ø 6.5       |    |

<sup>1)</sup> Securing screw for wall mounting: M6 (screw head max. 10.5 mm)  
All dimensions in [mm]

#### Dimensions (US units)

| A    | B    | C    | D    | E    | F    | G      | H      | J               | K    |
|------|------|------|------|------|------|--------|--------|-----------------|------|
| 8.46 | 9.84 | 3.56 | 6.27 | 5.31 | 3.54 | 1.77   | > 1.97 | 3.18            | 2.08 |
| L    | M    | N    | O    | P    | Q    | R      | S      | T <sup>1)</sup> |      |
| 3.74 | 2.08 | 4.01 | 3.20 | 0.45 | 7.55 | 8 × M5 | 0.79   | 2 × Ø 0.26      |      |

<sup>1)</sup> Securing screw for wall mounting: M6 (screw head max. 0.41")  
All dimensions in [inch]

There is a separate mounting kit for the wall-mounted housing. It can be ordered from Endress+Hauser as an accessory. The following installation variants are possible:

- Panel-mounted installation
- Pipe mounting

#### *Installation in control panel*

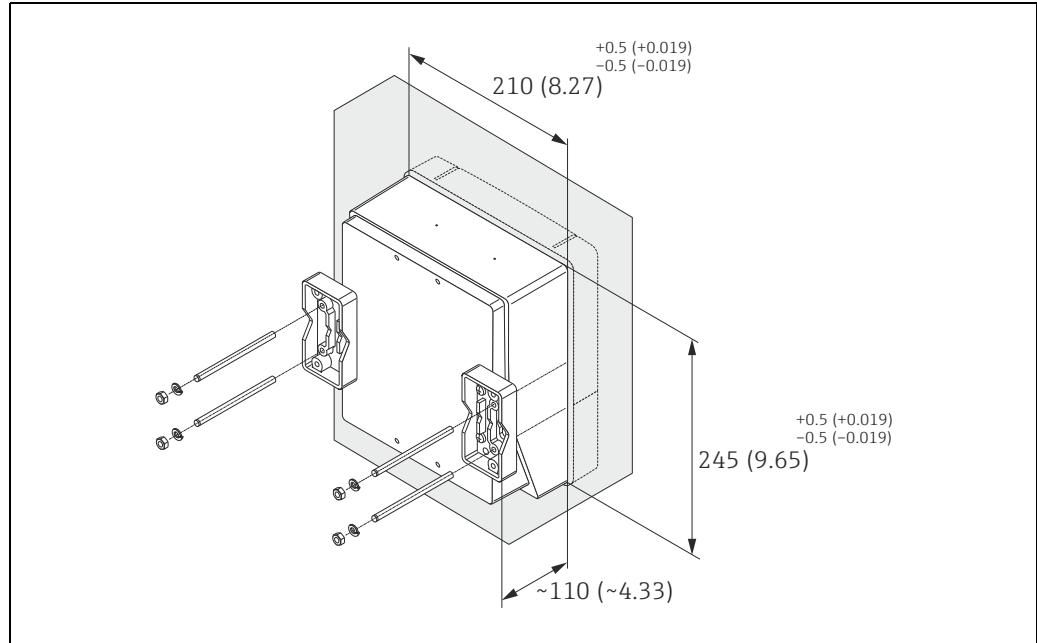

A0001131

#### *Pipe mounting*

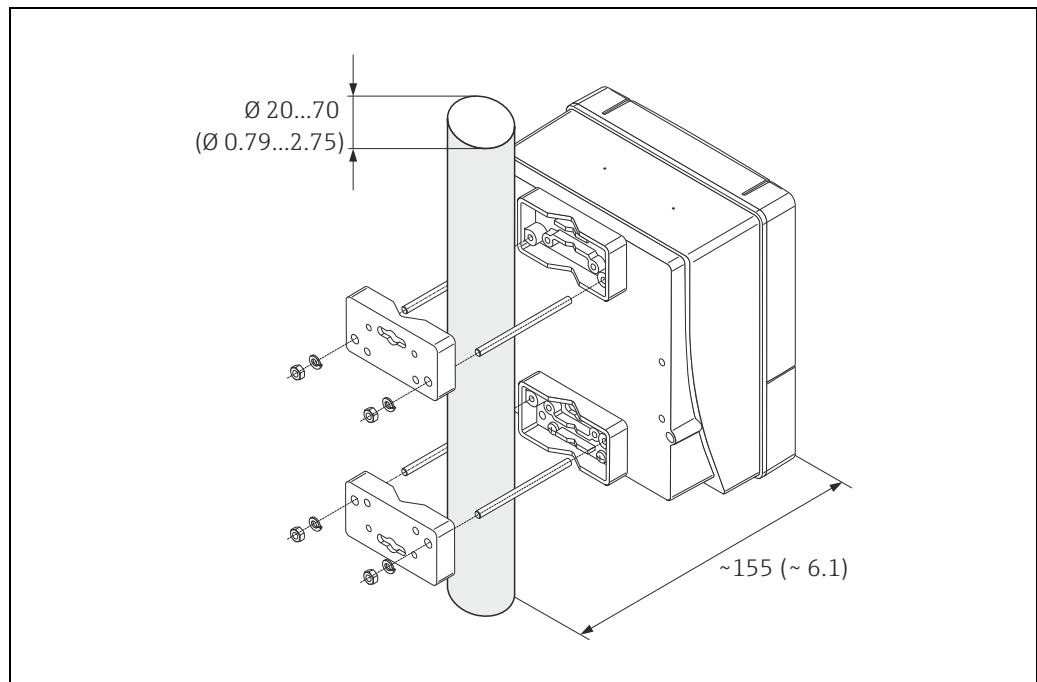

A0001132

Sensor, remote version DN ≤ 300 (12")

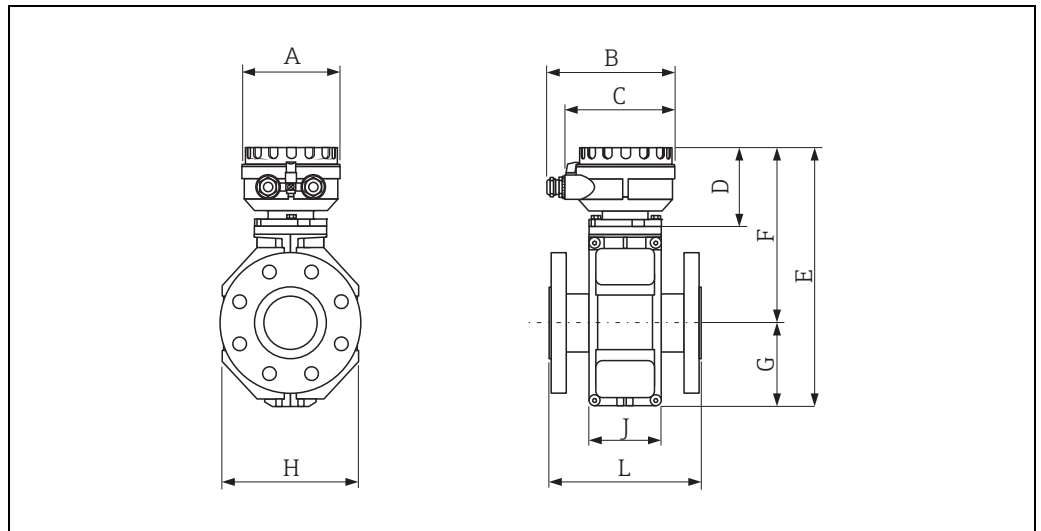

A0012462

Dimensions (SI units)

| DN<br>EN (DIN) / JIS / AS <sup>1)</sup> | A   | B   | C   | D   | E   | F   | G   | H   | J   | L   |
|---|-----|-----|-----|-----|-----|-----|-----|-----|-----|-----|
| 15                                      | 129 | 163 | 143 | 102 | 286 | 202 | 84  | 120 | 94  | 200 |
| 25                                      |     |     |     |     | 286 | 202 | 84  | 120 | 94  | 200 |
| 32                                      |     |     |     |     | 286 | 202 | 84  | 120 | 94  | 200 |
| 40                                      |     |     |     |     | 286 | 202 | 84  | 120 | 94  | 200 |
| 50                                      |     |     |     |     | 286 | 202 | 84  | 120 | 94  | 200 |
| 65                                      |     |     |     |     | 336 | 227 | 109 | 180 | 94  | 200 |
| 80                                      |     |     |     |     | 336 | 227 | 109 | 180 | 94  | 200 |
| 100                                     |     |     |     |     | 336 | 227 | 109 | 180 | 94  | 250 |
| 125                                     |     |     |     |     | 417 | 267 | 150 | 260 | 140 | 250 |
| 150                                     |     |     |     |     | 417 | 267 | 150 | 260 | 140 | 300 |
| 200                                     |     |     |     |     | 472 | 292 | 180 | 324 | 156 | 350 |
| 250                                     |     |     |     |     | 522 | 317 | 205 | 400 | 166 | 450 |
| 300                                     |     |     |     |     | 572 | 342 | 230 | 460 | 166 | 500 |

The fitting length (L) is always the same, regardless of the pressure rating.

<sup>1)</sup> Only DN 25 and DN 50 are available for flanges according to AS.

All dimensions in [mm]

*Dimensions (US units)*

| DN<br>ASME | A    | B    | C    | D    | E    | F    | G    | H    | J    | L    |
|------------|------|------|------|------|------|------|------|------|------|------|
| ½"         | 5.08 | 6.42 | 5.63 | 4.02 | 11.3 | 7.95 | 3.31 | 4.72 | 3.70 | 7.87 |
| 1"         |      |      |      |      | 11.3 | 7.95 | 3.31 | 4.72 | 3.70 | 7.87 |
| 1½"        |      |      |      |      | 11.3 | 7.95 | 3.31 | 4.72 | 3.70 | 7.87 |
| 2"         |      |      |      |      | 11.3 | 7.95 | 3.31 | 4.72 | 3.70 | 7.87 |
| 3"         |      |      |      |      | 13.2 | 8.94 | 4.29 | 7.09 | 3.70 | 7.87 |
| 4"         |      |      |      |      | 13.2 | 8.94 | 4.29 | 7.09 | 3.70 | 9.84 |
| 6"         |      |      |      |      | 16.4 | 10.5 | 5.91 | 10.2 | 5.51 | 11.8 |
| 8"         |      |      |      |      | 18.6 | 11.5 | 7.08 | 12.8 | 6.14 | 13.8 |
| 10"        |      |      |      |      | 20.6 | 12.5 | 8.07 | 15.8 | 6.54 | 17.7 |
| 12"        |      |      |      |      | 22.5 | 13.5 | 9.06 | 18.1 | 6.54 | 19.7 |

The fitting length (L) is always the same, regardless of the pressure rating.  
All dimensions in [inch]

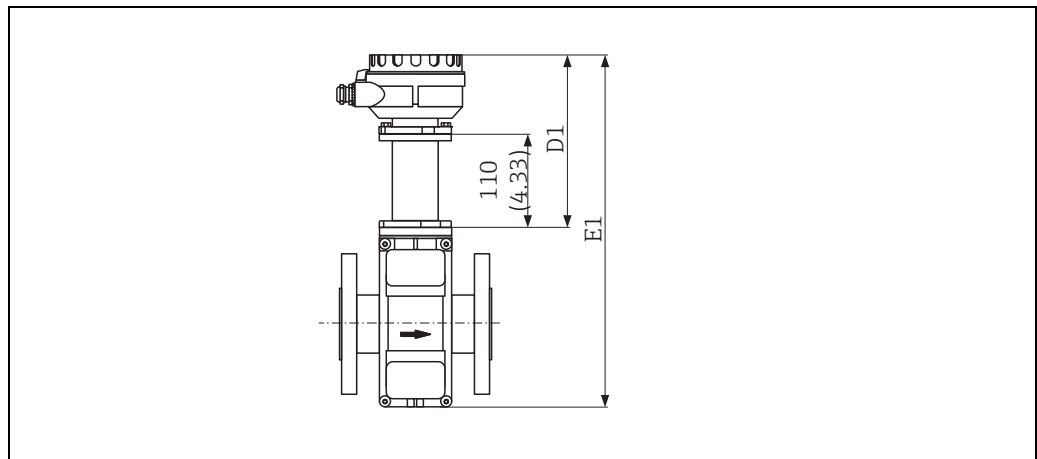
*High temperature version DN ≤ 300 (12")*

Measurement D1, E1 = Measurement D, E of the standard remote version plus 110 mm (4.33")

A0005570

Sensor, remote version DN ≥ 300 (12")

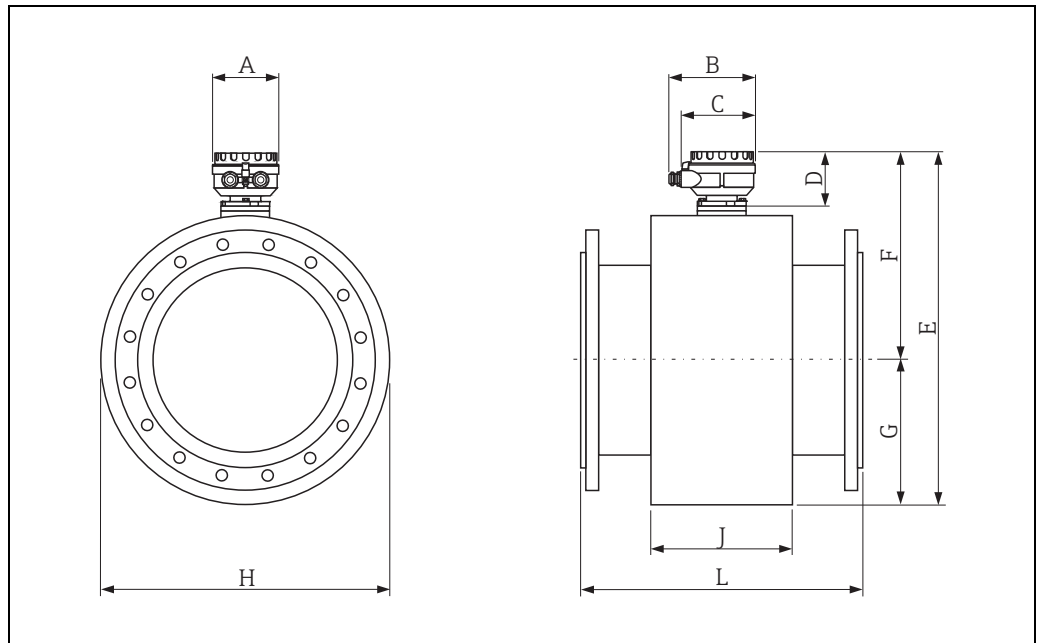

A0003220

Dimensions (SI units)

| DN<br>EN (DIN) | A   | B   | C   | D   | E     | F     | G     | H   | J   | L   |
|----------------|-----|-----|-----|-----|-------|-------|-------|-----|-----|-----|
| 350            | 129 | 163 | 143 | 102 | 683.5 | 401.5 | 282.0 | 564 | 288 | 550 |
| 400            |     |     |     |     | 735.5 | 427.5 | 308.0 | 616 | 288 | 600 |
| 450            |     |     |     |     | 785.5 | 452.5 | 333.0 | 666 | 292 | 650 |
| 500            |     |     |     |     | 836.5 | 478.0 | 358.5 | 717 | 292 | 650 |
| 600            |     |     |     |     | 940.5 | 530.0 | 410.5 | 821 | 402 | 780 |

The fitting length (L) is always the same, regardless of the pressure rating.  
All dimensions in [mm]

Dimensions (US units)

| DN<br>ASME | A    | B    | C    | D    | E    | F    | G    | H    | J    | L    |
|------------|------|------|------|------|------|------|------|------|------|------|
| 14"        | 5.08 | 6.42 | 5.63 | 4.02 | 26.9 | 15.8 | 11.1 | 22.2 | 11.3 | 21.7 |
| 16"        |      |      |      |      | 29.0 | 16.8 | 12.1 | 24.3 | 11.3 | 23.6 |
| 18"        |      |      |      |      | 30.9 | 17.8 | 13.1 | 26.2 | 11.5 | 25.6 |
| 20"        |      |      |      |      | 32.9 | 18.8 | 14.1 | 28.2 | 11.5 | 25.6 |
| 24"        |      |      |      |      | 37.0 | 20.9 | 16.2 | 32.3 | 15.8 | 30.7 |

The fitting length (L) is always the same, regardless of the pressure rating.  
All dimensions in [inch]

## Compact version DN ≤ 300 (12")

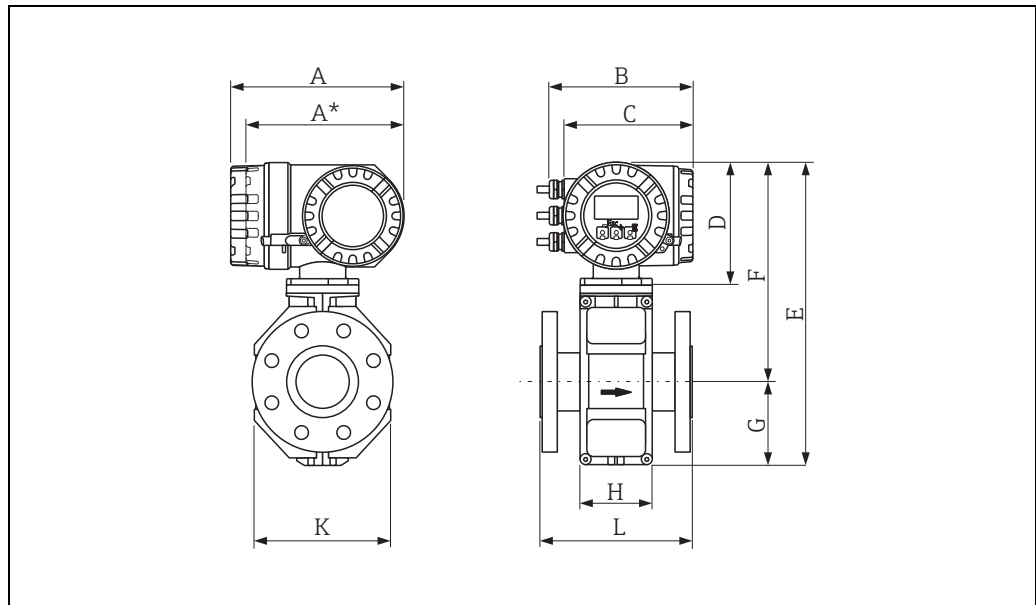

A0005423

## Dimensions (SI units)

| DN<br>EN (DIN) / JIS / AS <sup>1)</sup> | A   | A*  | B   | C   | D   | E   | F   | G   | H   | K   | L   |
|---|-----|-----|-----|-----|-----|-----|-----|-----|-----|-----|-----|
| 15                                      | 227 | 207 | 187 | 168 | 160 | 341 | 257 | 84  | 94  | 120 | 200 |
| 25                                      |     |     |     |     |     | 341 | 257 | 84  | 94  | 120 | 200 |
| 32                                      |     |     |     |     |     | 341 | 257 | 84  | 94  | 120 | 200 |
| 40                                      |     |     |     |     |     | 341 | 257 | 84  | 94  | 120 | 200 |
| 50                                      |     |     |     |     |     | 341 | 257 | 84  | 94  | 120 | 200 |
| 65                                      |     |     |     |     |     | 391 | 282 | 109 | 94  | 180 | 200 |
| 80                                      |     |     |     |     |     | 391 | 282 | 109 | 94  | 180 | 200 |
| 100                                     |     |     |     |     |     | 391 | 282 | 109 | 94  | 180 | 250 |
| 125                                     |     |     |     |     |     | 472 | 322 | 150 | 140 | 260 | 250 |
| 150                                     |     |     |     |     |     | 472 | 322 | 150 | 140 | 260 | 300 |
| 200                                     |     |     |     |     |     | 527 | 347 | 180 | 156 | 324 | 350 |
| 250                                     |     |     |     |     |     | 577 | 372 | 205 | 166 | 400 | 450 |
| 300                                     |     |     |     |     |     | 627 | 397 | 230 | 166 | 460 | 500 |

The fitting length (L) is always the same, regardless of the pressure rating.

<sup>1)</sup> Only DN 25 and DN 50 are available for flanges according to AS.

All dimensions in [mm]

Dimensions (US units)

| DN<br>ASME | A    | A*   | B    | C    | D    | E    | F    | G    | H    | K    | L    |
|------------|------|------|------|------|------|------|------|------|------|------|------|
| ½"         | 8.94 | 8.15 | 7.36 | 6.61 | 6.30 | 13.4 | 10.1 | 3.31 | 3.70 | 4.72 | 7.87 |
| 1"         |      |      |      |      |      | 13.4 | 10.1 | 3.31 | 3.70 | 4.72 | 7.87 |
| 1½"        |      |      |      |      |      | 13.4 | 10.1 | 3.31 | 3.70 | 4.72 | 7.87 |
| 2"         |      |      |      |      |      | 13.4 | 10.1 | 3.31 | 3.70 | 4.72 | 7.87 |
| 3"         |      |      |      |      |      | 15.4 | 11.1 | 4.29 | 3.70 | 7.09 | 7.87 |
| 4"         |      |      |      |      |      | 15.4 | 11.1 | 4.29 | 3.70 | 7.09 | 9.84 |
| 6"         |      |      |      |      |      | 18.6 | 12.7 | 5.91 | 5.51 | 10.2 | 11.8 |
| 8"         |      |      |      |      |      | 20.8 | 13.7 | 7.09 | 6.14 | 12.8 | 13.8 |
| 10"        |      |      |      |      |      | 22.7 | 14.7 | 8.07 | 6.54 | 15.8 | 17.7 |
| 12"        |      |      |      |      |      | 24.7 | 15.6 | 9.06 | 6.54 | 18.1 | 19.7 |

The fitting length (L) is always the same, regardless of the pressure rating.  
All dimensions in [inch]

High temperature version DN ≤ 300 (12")

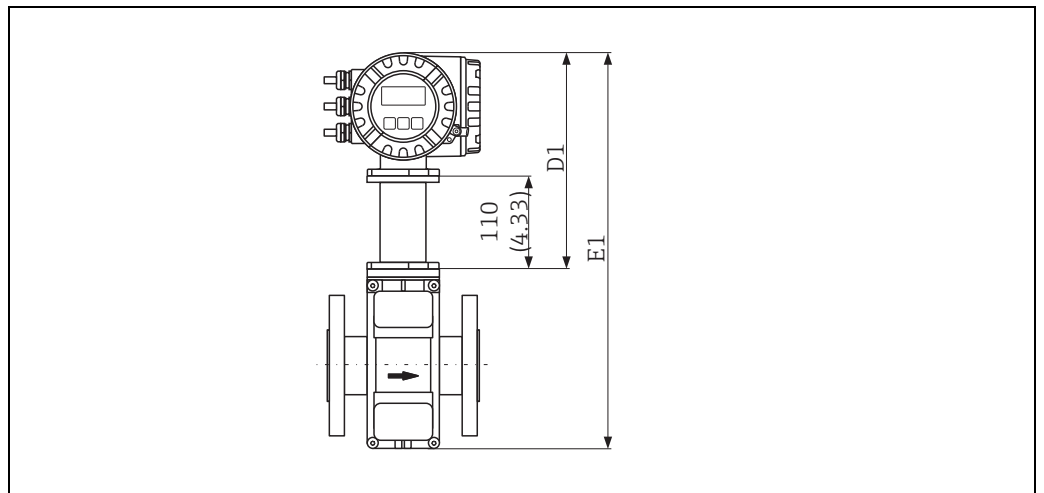

Measurement D1, E1 = Measurement D, E of the standard compact version plus 110 mm (4.33")

A0005529

Compact version DN ≥ 300 (12")

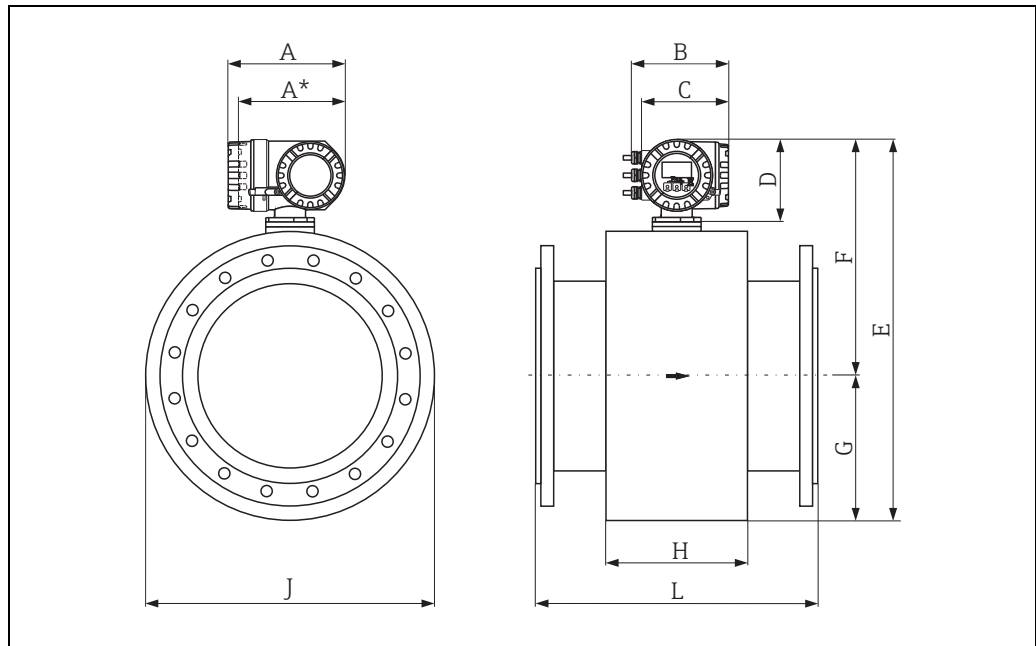

A0005424

Dimensions (SI units)

| DN<br>EN (DIN) | A   | A*  | B   | C   | D   | E     | F     | G     | H   | J   | L   |
|----------------|-----|-----|-----|-----|-----|-------|-------|-------|-----|-----|-----|
| 350            | 227 | 207 | 187 | 168 | 160 | 738.5 | 456.5 | 282.0 | 564 | 288 | 550 |
| 400            |     |     |     |     |     | 790.5 | 482.5 | 308.0 | 616 | 288 | 600 |
| 450            |     |     |     |     |     | 840.5 | 507.5 | 333.0 | 666 | 292 | 650 |
| 500            |     |     |     |     |     | 891.5 | 533.0 | 358.5 | 717 | 292 | 650 |
| 600            |     |     |     |     |     | 995.5 | 585.0 | 410.5 | 821 | 402 | 780 |

The fitting length (L) is always the same, regardless of the pressure rating.  
All dimensions in [mm]

Dimensions (US units)

| DN<br>ASME | A    | A*   | B    | C    | D    | E    | F    | G    | H    | J    | L    |
|------------|------|------|------|------|------|------|------|------|------|------|------|
| 14"        | 8.94 | 8.15 | 7.36 | 6.61 | 6.30 | 29.1 | 18.0 | 11.1 | 22.2 | 11.3 | 21.7 |
| 16"        |      |      |      |      |      | 31.1 | 19.0 | 12.1 | 24.3 | 11.3 | 23.6 |
| 18"        |      |      |      |      |      | 33.1 | 20.0 | 13.1 | 26.2 | 11.5 | 25.6 |
| 20"        |      |      |      |      |      | 35.1 | 21.0 | 14.1 | 28.2 | 11.5 | 25.6 |
| 24"        |      |      |      |      |      | 39.2 | 23.0 | 16.2 | 32.3 | 15.8 | 30.7 |

The fitting length (L) is always the same, regardless of the pressure rating.  
All dimensions in [inch]

Ground disk for flange connections

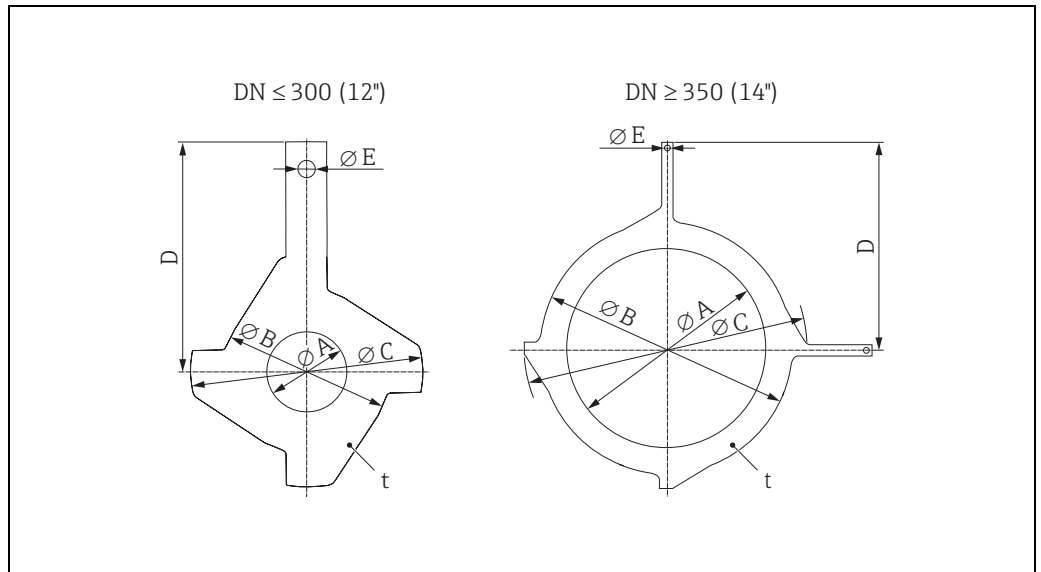

A0003221

Dimensions (SI units)

| DN <sup>1)</sup><br>EN (DIN) / JIS / AS <sup>4)</sup> | A  |                               | B   | C     | D    | E   | t |
|---|--|-------------------------------|-----|-------|------|-----|---|
|   | PTFE, PFA, PU, HR, NR <sub>a</sub> <sup>5)</sup> | NR <sub>b</sub> <sup>5)</sup> |     |       |      |     |   |
| 15  | 16   | -                             | 43  | 61.5  | 73   | 6.5 | 2 |
| 25  | 26   | -                             | 62  | 77.5  | 87.5 |     |   |
| 32  | 35   | -                             | 80  | 87.5  | 94.5 |     |   |
| 40  | 41   | -                             | 82  | 101   | 103  |     |   |
| 50  | 52   | -                             | 101 | 115.5 | 108  |     |   |
| 65  | 68   | 53                            | 121 | 131.5 | 118  |     |   |
| 80  | 80   | 66                            | 131 | 154.5 | 135  |     |   |
| 100   | 104  | 91.5                          | 156 | 186.5 | 153  |     |   |
| 125   | 130  | 117                           | 187 | 206.5 | 160  |     |   |
| 150   | 158  | 143.5                         | 217 | 256   | 184  |     |   |
| 200   | 206  | 192                           | 267 | 288   | 205  |     |   |
| 250   | 260  | 245                           | 328 | 359   | 240  |     |   |
| 300 <sup>2)</sup>                                     | 312  | 294.5                         | 375 | 413   | 273  |     |   |
| 300 <sup>3)</sup>                                     | 310  | -                             | 375 | 404   | 268  |     |   |
| 350 <sup>2)</sup>                                     | 343  | 323.5                         | 433 | 479   | 365  | 9.0 |   |
| 400 <sup>2)</sup>                                     | 393  | 371                           | 480 | 542   | 395  |     |   |
| 450 <sup>2)</sup>                                     | 439  | 420                           | 538 | 583   | 417  |     |   |
| 500 <sup>2)</sup>                                     | 493  | 469                           | 592 | 650   | 460  |     |   |
| 600 <sup>2)</sup>                                     | 593  | 566                           | 693 | 766   | 522  |     |   |

<sup>1)</sup> Ground disks at DN 15 to 250 can be used for all flange standards/nominal pressures available as standard.  
<sup>2)</sup> PN 10/16, CI 150  
<sup>3)</sup> PN 25, JIS 10K/20K  
<sup>4)</sup> Only DN 25 and DN 50 are available for flanges according to AS.  
<sup>5)</sup> Abbreviations (lining): PU = Polyurethane, HR = Hard rubber, NR<sub>a</sub> = Natural rubber thin, NR<sub>b</sub> = Natural rubber thick  
 All dimensions in [mm]

## Dimensions (US units)

| DN <sup>1)</sup><br>ASME | A  |                               | B    | C     | D    | E    | t    |
|--------------------------|--|-------------------------------|------|-------|------|------|------|
|                          | PTFE, PFA, PU, HR, NR <sub>a</sub> <sup>2)</sup> | NR <sub>b</sub> <sup>2)</sup> |      |       |      |      |      |
| ½"                       | 0.63   | –                             | 1.69 | 2.42  | 2.87 | 0.26 | 0.08 |
| 1"                       | 1.02   | –                             | 2.44 | 3.05  | 3.44 |      |      |
| 1½"                      | 1.61   | –                             | 3.23 | 3.98  | 4.06 |      |      |
| 2"                       | 2.05   | –                             | 3.98 | 4.55  | 4.25 |      |      |
| 3"                       | 3.15   | 2.60                          | 5.16 | 6.08  | 5.31 |      |      |
| 4"                       | 4.09   | 3.60                          | 6.14 | 7.34  | 6.02 |      |      |
| 6"                       | 6.22   | 5.65                          | 8.54 | 10.08 | 7.24 |      |      |
| 8"                       | 8.11   | 7.56                          | 10.5 | 11.3  | 8.07 |      |      |
| 10"                      | 10.2   | 9.65                          | 12.9 | 14.1  | 9.45 |      |      |
| 12"                      | 12.3   | 11.6                          | 14.8 | 16.3  | 10.8 |      |      |
| 14"                      | 13.5   | 12.7                          | 17.1 | 18.9  | 14.4 |      |      |
| 16"                      | 15.45  | 14.6                          | 18.9 | 21.3  | 15.6 |      |      |
| 18"                      | 17.3   | 16.5                          | 21.2 | 23.0  | 16.4 |      |      |
| 20"                      | 19.4   | 18.5                          | 23.3 | 25.6  | 18.1 |      |      |
| 24"                      | 23.4   | 22.3                          | 27.3 | 30.1  | 20.6 |      |      |

<sup>1)</sup> Ground disks can be used for all pressure ratings.

<sup>2)</sup> Abbreviations (lining): PU = Polyurethane, HR = Hard rubber, NR<sub>a</sub> = Natural rubber thin, NR<sub>b</sub> = Natural rubber thick

All dimensions in [inch]

**Weight**

Weight in [kg]

| Nominal diameter<br>[mm] | Weight in kilograms [kg] |                |                                     |                                |       |                                     |     |      |     |
|--------------------------|--------------------------|----------------|-------------------------------------|--------------------------------|-------|-------------------------------------|-----|------|-----|
|                          | Compact version          |                |                                     | Remote version (without cable) |       |                                     |     |      |     |
|                          | Sensor                   |                | Transmitter<br>(Wall-mount housing) | Sensor                         |       | Transmitter<br>(Wall-mount housing) |     |      |     |
| EN (DIN) / AS*           | JIS                      | EN (DIN) / AS* |                                     | JIS                            |       |                                     |     |      |     |
| 15                       | PN 40                    | 6.5            | 10K<br>10K                          | 6.5                            | PN 40 | 4.5                                 | 10K | 4.5  | 6.0 |
| 25                       |                          | 7.3            |                                     | 7.3                            |       | 5.3                                 |     | 5.3  | 6.0 |
| 32                       |                          | 8.0            |                                     | 7.3                            |       | 6.0                                 |     | 5.3  | 6.0 |
| 40                       |                          | 9.4            |                                     | 8.3                            |       | 7.4                                 |     | 6.3  | 6.0 |
| 50                       |                          | 10.6           |                                     | 9.3                            |       | 8.6                                 |     | 7.3  | 6.0 |
| 65                       | PN 16                    | 12.0           | 10K<br>10K                          | 11.1                           | PN 16 | 10.0                                | 10K | 9.1  | 6.0 |
| 80                       |                          | 14.0           |                                     | 12.5                           |       | 12.0                                |     | 10.5 | 6.0 |
| 100                      |                          | 16.0           |                                     | 14.7                           |       | 14.0                                |     | 12.7 | 6.0 |
| 125                      |                          | 21.5           |                                     | 21.0                           |       | 19.5                                |     | 19.0 | 6.0 |
| 150                      |                          | 25.5           |                                     | 24.5                           |       | 23.5                                |     | 22.5 | 6.0 |
| 200                      | PN 10                    | 45             | 10K<br>10K                          | 41.9                           | PN 10 | 43                                  | 10K | 39.9 | 6.0 |
| 250                      |                          | 65             |                                     | 69.4                           |       | 63                                  |     | 67.4 | 6.0 |
| 300                      |                          | 70             |                                     | 72.3                           |       | 68                                  |     | 70.3 | 6.0 |
| 350                      |                          | 115            |                                     | 79                             |       | 113                                 |     | 77   | 6.0 |
| 400                      |                          | 135            |                                     | 100                            |       | 133                                 |     | 98   | 6.0 |
| 450                      |                          | 175            |                                     | 128                            |       | 173                                 |     | 126  | 6.0 |
| 500                      |                          | 175            |                                     | 142                            |       | 173                                 |     | 140  | 6.0 |
| 600                      |                          | 235            |                                     | 188                            |       | 233                                 |     | 186  | 6.0 |

Transmitter (compact version): 3.4 kg  
 High-temperature version: +1.5 kg  
 \* Only DN 25 and 50 are available for flanges according to AS

Weight in [lbs]

| Nominal diameter<br>[inch]   | Weight in pounds [lbs] |     |                                |                                  |    |
|--|------------------------|-----|--------------------------------|----------------------------------|----|
|  | Compact version        |     | Remote version (without cable) |                                  |    |
|  | ASME                   |     | Sensor ASME                    | Transmitter (Wall-mount housing) |    |
| ½"   | Class 150              | 14  | Class 150                      | 10                               | 13 |
| 1"   |                        | 16  |                                | 12                               | 13 |
| 1 ½"   |                        | 21  |                                | 16                               | 13 |
| 2"   |                        | 23  |                                | 19                               | 13 |
| 3"   |                        | 31  |                                | 26                               | 13 |
| 4"   |                        | 35  |                                | 31                               | 13 |
| 6"   |                        | 56  |                                | 52                               | 13 |
| 8"   |                        | 99  |                                | 95                               | 13 |
| 10"  |                        | 165 |                                | 161                              | 13 |
| 12"  |                        | 243 |                                | 238                              | 13 |
| 14"  |                        | 386 |                                | 381                              | 13 |
| 16"  |                        | 452 |                                | 448                              | 13 |
| 18"  |                        | 562 |                                | 558                              | 13 |
| 20"  |                        | 628 |                                | 624                              | 13 |
| 24"  |                        | 893 |                                | 889                              | 13 |
| Transmitter (compact version): 7.5 lbs<br>High-temperature version: +3.3 lbs |                        |     |                                |                                  |    |

**Measuring tube specifications**

| Measuring tube specifications - Promag S (SI units) |        |                 |         |         |            |     |                                   |                |                      |                      |                                   |                                   |
|---|--------|-----------------|---------|---------|------------|-----|-----------------------------------|----------------|----------------------|----------------------|-----------------------------------|-----------------------------------|
| Nominal diameter                                    |        | Pressure rating |         |         |            |     | Inside diameter of measuring tube |                |                      |                      |                                   |                                   |
| [mm]  | [inch] | EN (DIN) [bar]  | AS 2129 | AS 4087 | ASME [lbs] | JIS | with PFA [mm]                     | with PTFE [mm] | PU <sup>‡</sup> [mm] | HR <sup>‡</sup> [mm] | NR <sub>a</sub> <sup>‡</sup> [mm] | NR <sub>b</sub> <sup>‡</sup> [mm] |
| 15  | ½"     | PN 40           | -       | -       | Cl 150     | 20K | -                                 | 15             | -                    | -                    | -                                 | -                                 |
| 25  | 1"     | PN 40           | Table E | -       | Cl 150     | 20K | 23                                | 26             | 24                   | -                    | -                                 | -                                 |
| 32  | -      | PN 40           | -       | -       | -          | 20K | 32                                | 35             | 32                   | -                    | -                                 | -                                 |
| 40  | 1½"    | PN 40           | -       | -       | Cl 150     | 20K | 36                                | 41             | 38                   | -                    | -                                 | -                                 |
| 50  | 2"     | PN 40           | Table E | PN 16   | Cl 150     | 10K | 48                                | 52             | 50                   | 50                   | -                                 | -                                 |
| 65  | -      | PN 16           | -       | -       | -          | 10K | 63                                | 67             | 66                   | 66                   | 63                                | 52                                |
| 80  | 3"     | PN 16           | Table E | PN 16   | Cl 150     | 10K | 75                                | 80             | 79                   | 79                   | 76                                | 65                                |
| 100   | 4"     | PN 16           | Table E | PN 16   | Cl 150     | 10K | 101                               | 104            | 102                  | 102                  | 101                               | 91                                |
| 125   | -      | PN 16           | -       | -       | -          | 10K | 126                               | 129            | 127                  | 127                  | 127                               | 116                               |
| 150   | 6"     | PN 16           | Table E | PN 16   | Cl 150     | 10K | 154                               | 156            | 156                  | 156                  | 155                               | 142                               |
| 200   | 8"     | PN 10           | Table E | PN 16   | Cl 150     | 10K | 201                               | 202            | 204                  | 204                  | 204                               | 190                               |
| 250   | 10"    | PN 10           | Table E | PN 16   | Cl 150     | 10K | -                                 | 256            | 258                  | 258                  | 258                               | 244                               |
| 300   | 12"    | PN 10           | Table E | PN 16   | Cl 150     | 10K | -                                 | 306            | 309                  | 309                  | 309                               | 292                               |
| 350   | 14"    | PN 10           | Table E | PN 16   | Cl 150     | 10K | -                                 | 337            | 342                  | 342                  | 341                               | 322                               |
| 400   | 16"    | PN 10           | Table E | PN 16   | Cl 150     | 10K | -                                 | 387            | 392                  | 392                  | 391                               | 369                               |
| 450   | 18"    | PN 10           | Table E | PN 16   | Cl 150     | 10K | -                                 | 432            | 437                  | 437                  | 440                               | 417                               |
| 500   | 20"    | PN 10           | Table E | PN 16   | Cl 150     | 10K | -                                 | 487            | 492                  | 492                  | 491                               | 466                               |
| 600   | 24"    | PN 10           | Table E | PN 16   | Cl 150     | 10K | -                                 | 593            | 594                  | 594                  | 593                               | 562                               |

<sup>‡</sup> Abbreviations (lining): PU = Polyurethane, HR = Hard rubber, NR<sub>a</sub> = Natural rubber thin, NR<sub>b</sub> = Natural rubber thick

| Measuring tube specifications - Promag S (US units) |      |                 |         |         |            |     |                                   |                  |                        |                        |                                     |                                     |
|---|------|-----------------|---------|---------|------------|-----|-----------------------------------|------------------|------------------------|------------------------|-------------------------------------|-------------------------------------|
| Nominal diameter                                    |      | Pressure rating |         |         |            |     | Inside diameter of measuring tube |                  |                        |                        |                                     |                                     |
|   |      | EN (DIN) [bar]  | AS 2129 | AS 4087 | ASME [lbs] | JIS | with PFA [inch]                   | with PTFE [inch] | PU <sup>‡</sup> [inch] | HR <sup>‡</sup> [inch] | NR <sub>a</sub> <sup>‡</sup> [inch] | NR <sub>b</sub> <sup>‡</sup> [inch] |
| [inch]  | [mm] |                 |         |         |            |     |                                   |                  |                        |                        |                                     |                                     |
| ½"  | 15   | PN 40           | -       | -       | Cl 150     | 20K | -                                 | 0.59             | -                      | -                      | -                                   | -                                   |
| 1"  | 25   | PN 40           | Table E | -       | Cl 150     | 20K | 0.91                              | 1.02             | 0.94                   | -                      | -                                   | -                                   |
| -   | 32   | PN 40           | -       | -       | -          | 20K | 1.26                              | 1.34             | 1.26                   | -                      | -                                   | -                                   |
| 1½"   | 40   | PN 40           | -       | -       | Cl 150     | 20K | 1.42                              | 1.61             | 1.50                   | -                      | -                                   | -                                   |
| 2"  | 50   | PN 40           | Table E | PN 16   | Cl 150     | 10K | 1.89                              | 2.05             | 1.97                   | 1.97                   | -                                   | -                                   |
| -   | 65   | PN 16           | -       | -       | -          | 10K | 2.48                              | 2.64             | 2.60                   | 2.60                   | 2.48                                | 2.05                                |
| 3"  | 80   | PN 16           | -       | -       | Cl 150     | 10K | 2.95                              | 3.15             | 3.11                   | 3.11                   | 2.99                                | 2.56                                |
| 4"  | 100  | PN 16           | -       | -       | Cl 150     | 10K | 3.98                              | 4.09             | 4.02                   | 4.02                   | 3.98                                | 3.58                                |
| -   | 125  | PN 16           | -       | -       | -          | 10K | 4.96                              | 5.08             | 5.00                   | 5.00                   | 5.00                                | 4.57                                |
| 6"  | 150  | PN 16           | -       | -       | Cl 150     | 10K | 6.06                              | 6.14             | 6.14                   | 6.14                   | 6.10                                | 5.59                                |
| 8"  | 200  | PN 10           | -       | -       | Cl 150     | 10K | 7.91                              | 7.92             | 8.03                   | 8.03                   | 8.03                                | 7.48                                |
| 10"   | 250  | PN 10           | -       | -       | Cl 150     | 10K | -                                 | 10.08            | 10.16                  | 10.16                  | 10.16                               | 9.61                                |
| 12"   | 300  | PN 10           | -       | -       | Cl 150     | 10K | -                                 | 12.05            | 12.17                  | 12.17                  | 12.17                               | 11.50                               |
| 14"   | 350  | PN 10           | -       | -       | Cl 150     | 10K | -                                 | 13.27            | 13.46                  | 13.46                  | 13.43                               | 12.68                               |
| 16"   | 400  | PN 10           | -       | -       | Cl 150     | 10K | -                                 | 15.24            | 15.43                  | 15.43                  | 15.39                               | 14.53                               |
| 18"   | 450  | PN 10           | -       | -       | Cl 150     | 10K | -                                 | 17.01            | 17.20                  | 17.20                  | 17.32                               | 16.42                               |
| 20"   | 500  | PN 10           | -       | -       | Cl 150     | 10K | -                                 | 19.17            | 19.37                  | 19.37                  | 19.33                               | 18.35                               |
| 24"   | 600  | PN 10           | -       | -       | Cl 150     | 10K | -                                 | 23.35            | 23.39                  | 23.39                  | 23.35                               | 22.13                               |

‡ Abbreviations (lining): PU = Polyurethane, HR = Hard rubber, NR<sub>a</sub> = Natural rubber thin, NR<sub>b</sub> = Natural rubber thick

| Nominal diameter |      | Inside diameter of measuring tube with natural rubber NR <sub>b</sub> <sup>1)</sup> |       | Thickness of lining material natural rubber NR <sub>b</sub> <sup>1)</sup> |      |    |
|------------------|------|---|-------|---|------|----|
| [inch]           | [mm] | [inch]  | [mm]  | [inch]  | [mm] |    |
| 2½"              | 65   | PN 16/150 lbs   | 2.05  | 52  | 0.39 | 10 |
| 3"               | 80   |   | 2.56  | 65  | 0.39 | 10 |
| 4"               | 100  |   | 3.58  | 91  | 0.39 | 10 |
| 5"               | 125  |   | 4.57  | 116   | 0.39 | 10 |
| 6"               | 150  |   | 5.59  | 142   | 0.47 | 12 |
| 8"               | 200  |   | 6.30  | 190   | 0.47 | 12 |
| 10"              | 250  | PN 10   | 9.61  | 244   | 0.47 | 12 |
| 12"              | 300  |   | 11.50 | 292   | 0.51 | 13 |
| 14"              | 350  |   | 12.68 | 322   | 0.55 | 14 |
| 16"              | 400  |   | 14.53 | 369   | 0.63 | 16 |
| 18"              | 450  |   | 16.42 | 417   | 0.55 | 14 |
| 20"              | 500  |   | 18.35 | 466   | 0.67 | 17 |
| 24"              | 600  | 22.13   | 562   | 0.79  | 20   |    |
| 10"              | 250  | 150 lbs   | 9.57  | 243   | 0.47 | 12 |
| 12"              | 300  |   | 11.46 | 291   | 0.47 | 12 |
| 14"              | 350  |   | 12.60 | 320   | 0.51 | 13 |
| 16"              | 400  |   | 14.49 | 368   | 0.55 | 14 |
| 18"              | 450  |   | 16.42 | 417   | 0.55 | 14 |
| 20"              | 500  |   | 18.31 | 465   | 0.63 | 16 |
| 24"              | 600  | 22.17   | 563   | 0.63  | 16   |    |

≠ NR<sub>b</sub> = Natural rubber thick

**Material**

Transmitter housing:

- Compact and remote version: Powder-coated die-cast aluminum

Sensor housing:

- DN 15 to 300 (½ to 12"): Powder-coated die-cast aluminum
- DN 350 to 600 (14 to 24"): Painted steel

Measuring tube:

- DN < 350 (14"): Stainless steel 1.4301 (304) or 1.4306 (304L). For flanges of carbon steel with Al/Zn protective coating.
- DN > 300 (12"): Stainless steel 1.4301 (304). For flanges of carbon steel with protective paint finish.

Flange:

- EN 1092-1 (DIN 2501): S235JRG2, S2345JR+N, P245GH, P250GH, E250C, A105, 1.4571, F316L (DN < 350 (14"): with Al/Zn protective coating; DN > 300 (12") with protective paint finish)
- ASME B16.5: A105; F316L (DN < 350 (14") with Al/Zn protective coating; DN > 300 (12") with protective paint finish)
- JIS B2220: A105, A350 LF2, F316L (DN < 350 (14") with Al/Zn protective coating; DN > 300 (12") with protective paint finish)
- AS 2129: A105, P235GH, P265GH, S235JRG2, with Al/Zn protective coating
- AS 4087: A105, P265GH, S275JR, with Al/Zn protective coating

Ground disks: 1.4435 (316L) or Alloy C-22

---

Electrodes:

- 1.4435 (316L), platinum, Alloy C-22, tantalum, titanium Gr. 2, tungsten carbide coating (for electrodes made from 1.4435)
- 1.4310 (302) (for brush electrodes), Duplex 1.4462, Alloy X750 (for brush electrodes)

Seals: according to DIN EN 1514-1 form IBC

---

**Fitted electrodes**

Comes as standard:

- 2 measuring electrodes for signal detection
- 1 EPD electrode for empty pipe detection
- 1 Reference electrode for potential equalization

Optionally available for measuring electrodes made of platinum:

- 1 EPD electrode for empty pipe detection
- 1 Reference electrode for potential equalization

For measuring tube with natural rubber lining in combination with brush electrodes:

- 2 brush electrodes for signal detection
- 

**Process connections**

Flange connection:

- EN 1092-1 (DIN 2501)
    - DN < 300 (12"): Form A
    - DN > 300 (12"): Form B
    - DN 65 (2½") PN 16 and DN 600 (24") PN 16 exclusively according to EN 1092-1
  - ASME B16.5
  - JIS B2220
  - AS 2129
  - AS 4087
- 

**Surface roughness**

- Lining with PFA:  $\leq 0.4 \mu\text{m}$  (16  $\mu\text{in}$ )
- Electrodes: 0.3 to 0.5  $\mu\text{m}$  (12 to 20  $\mu\text{in}$ )

All data relate to wetted parts.

## Operability

---

### Local operation

#### Display elements

- Liquid-crystal display: illuminated, four lines with 16 characters per line
- Custom configurations for presenting different measured values and status variables
- 3 totalizers
- At ambient temperatures below  $-20\text{ °C}$  ( $-4\text{ °F}$ ), the readability of the display may be impaired.

#### Operating elements

- Onsite operation with three optical sensor keys (□/⊕/⊞)
  - Application-specific Quick Setup menus for straightforward commissioning
- 

### Language groups

Language groups available for operation in different countries:

- Western Europe and America (WEA):  
English, German, Spanish, Italian, French, Dutch, Portuguese
  - Eastern Europe/Scandinavia (EES):  
English, Russian, Polish, Norwegian, Finnish, Swedish, Czech
  - South and East Asia (SEA):  
English, Japanese, Indonesian
  - China (CN):  
English, Chinese
- 

### Remote operation

Remote operation via HART, PROFIBUS DP/PA, FOUNDATION Fieldbus

---

## Certificates and approvals

|  |  |
|--|--|
| <b>CE mark</b>                           | The measuring system described in these Operating Instructions therefore complies with the legal requirements of the EU Directives. Endress+Hauser confirms this by affixing the CE mark to it and by issuing the CE declaration of conformity.  |
| <b>C-tick symbol</b>                     | The measuring system meets the EMC requirements of the "Australian Communications and Media Authority (ACMA)".   |
| <b>Ex approval</b>                       | Information on the currently available Ex-rated versions (ATEX, FM, CSA etc.) is available on request from your Endress+Hauser sales outlet. All information relevant to explosion protection is available in separate documents that you can order as necessary.  |
| <b>Sanitary compatibility</b>            | No applicable approvals or certification   |
| <b>Pressure equipment directive</b>      | <p>The measuring devices can be ordered with or without PED (Pressure Equipment Directive). If a device with PED is required, this must be ordered explicitly. For devices with nominal diameters less than or equal to DN 25 (1"), this is neither possible nor necessary.</p> <ul style="list-style-type: none"> <li>■ With the identification PED/G1/III on the sensor nameplate, Endress+Hauser confirms conformity with the "Basic safety requirements" of Appendix I of the Pressure Equipment Directive 2014/68/EU.</li> <li>■ Devices with this identification (with PED) are suitable for the following types of fluid: <ul style="list-style-type: none"> <li>– Fluids of Group 1 and 2 with a steam pressure of greater or less than 0.5 bar (7.3 psi)</li> <li>– Unstable gases</li> </ul> </li> <li>■ Devices without this identification (without PED) are designed and manufactured according to good engineering practice. They correspond to the requirements of Art.4, Section 3 of the Pressure Equipment Directive 2014/68/EU. Their application is illustrated in Diagrams 6 to 9 in Appendix II of the Pressure Equipment Directive 2014/68/EU.</li> </ul> |
| <b>FOUNDATION Fieldbus certification</b> | <p>The flow device has successfully passed all the test procedures carried out and is certified and registered by the Fieldbus Foundation. The device thus meets all the requirements of the following specifications:</p> <ul style="list-style-type: none"> <li>■ Certified to FOUNDATION Fieldbus Specification</li> <li>■ The device meets all the specifications of the FOUNDATION Fieldbus H1</li> <li>■ Interoperability Test Kit (ITK), revision status 5.1 (device certification number: on request)</li> <li>■ The device can also be operated with certified devices of other manufacturers</li> <li>■ Physical Layer Conformance Test of the Fieldbus Foundation</li> </ul>  |
| <b>PROFIBUS DP/PA certification</b>      | <p>The flowmeter has successfully passed all the test procedures carried out and is certified and registered by the PNO (PROFIBUS User Organization). The device thus meets all the requirements of the following specifications:</p> <ul style="list-style-type: none"> <li>■ Certified in accordance with PROFIBUS Profile Version 3.0 (device certification number: available on request)</li> <li>■ The measuring device can also be operated with certified devices of other manufacturers (interoperability)</li> </ul>  |
| <b>Other standards and guidelines</b>    | <ul style="list-style-type: none"> <li>■ EN 60529<br/>Degrees of protection by housing (IP code)</li> <li>■ EN 61010-1<br/>Protection Measures for Electrical Equipment for Measurement, Control, Regulation and Laboratory Procedures</li> <li>■ IEC/EN 61326<br/>"Emission in accordance with requirements for class A".<br/>Electromagnetic compatibility (EMC requirements).</li> <li>■ ANSI/ISA-S82.01<br/>Safety Standard for Electrical and Electronic Test, Measuring, Controlling and related Equipment - General Requirements. Pollution degree 2, Installation Category II.</li> <li>■ CAN/CSA-C22.2 (No. 1010.1-92)<br/>Safety requirements for Electrical Equipment for Measurement and Control and Laboratory Use. Pollution degree 2, Installation Category I.</li> </ul>   |

- NAMUR NE 21  
Electromagnetic compatibility (EMC) of industrial process and laboratory control equipment.
- NAMUR NE 43  
Standardization of the signal level for the breakdown information of digital transmitters with analog output signal.
- NAMUR NE 53  
Software of field devices and signal-processing devices with digital electronics.

## Ordering information



Note!

Endress+Hauser reserves the right to change or modify product, specifications, and ordering information at any time without notice. Please consult Endress+Hauser or your local representative for the most recent information.

## Accessories

Various accessories are available for the transmitter and the sensor. These can be ordered separately from Endress+Hauser.



Note!

For detailed information on specific order codes, please contact the Endress+Hauser service organization.

## Documentation

- Flow Measurement (FA005D)
- Technical Information
  - Promag 55H (TI00096D)
- Operating Instructions/Description of Device Functions
  - Promag 55 HART (BA00119D/BA00120D)
  - Promag 55 PROFIBUS DP/PA (BA00124D/BA00125D)
  - Promag 55 FOUNDATION Fieldbus (BA00126D/BA00127D)
- Supplementary documentation on Ex-ratings: ATEX, FM, CSA

## Registered trademarks

HART®

Registered trademark of HART Communication Foundation, Austin, USA

PROFIBUS®

Registered trademark of the PROFIBUS User Organisation, Karlsruhe, Germany

FOUNDATION™ Fieldbus

Registered trademark of the Fieldbus Foundation, Austin, USA

HistoROM™, S-DAT®, T-DAT®, F-CHIP®, FieldCare®, Fieldcheck®, Applicator®

Registered or registration-pending trademarks of the Endress+Hauser Group





[www.addresses.endress.com](http://www.addresses.endress.com)

---