



Level



Pressure



Flow



Temperature



Liquid
Analysis



Registration



Systems
Components



Services



Solutions

Operating Instructions

Liquiport 2010 CSP44

Automatic sampler for liquid media

Maintenance & diagnostics

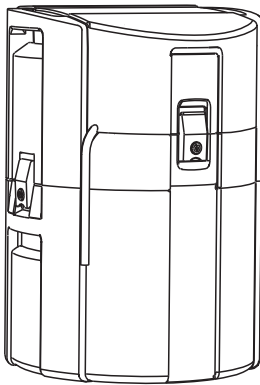

BA470C/07/EN/06.10
71118810

Valid as of:
Software version 01.01.00

Endress+Hauser

People for Process Automation

About this manual

This manual describes all the tasks you must perform for maintenance, diagnostics and troubleshooting.

A description of the following is provided here:

- "Diagnostics" menu
 - Diagnostics list
 - Logbooks
 - System information
 - State of Outputs
 - Systemtest/Reset
 - Sensor change
 - Manual hold
 - Term information
 - Simulation
 - Sensor information
- Cleaning and maintenance
- Troubleshooting
- Accessories and spare parts

This manual does not include the following:

- Setup/General settings
 - Operating Instructions BA465C "Commissioning"
- Display/Operation
 - Operating Instructions BA465C "Commissioning"
- Inputs
 - Operating Instructions BA464C "Operation&settings"
- Outputs
 - Operating Instructions BA464C "Operation&settings"
- Sampling programs
 - Operating Instructions BA464C "Operation&settings"
- Additional functions
 - Operating Instructions BA464C "Operation&settings"
- Data management
 - Operating Instructions BA464C "Operation&settings"
- Calibration
 - Operating Instructions BA467C "Calibration"
- Expert
 - Internal Service Manual

Table of contents

1	Maintenance	4
1.1	Recommended maintenance	4
1.2	Replacing the pump tube	5
1.3	Cleaning	6
1.4	Calibration	9
1.5	Replacing the batteries	10
2	Diagnostics menu	11
2.1	Diagnostics list	11
2.2	Logbooks	11
2.3	System information	14
2.4	Status of inputs/outputs	15
2.5	Systemtest/Reset	15
2.6	Sensor change (for version with sensors with the Memosens protocol)	17
2.7	Manual hold (for version with sensors with the Memosens protocol)	17
2.8	Term information	17
2.9	Simulation	18
2.10	Sensor information (for version with sensors with the Memosens protocol)	18
3	Troubleshooting	19
3.1	Troubleshooting	19
3.2	System error messages	19
3.3	Device-specific errors	37
3.4	Process errors without messages	39
3.5	Return	44
3.6	Disposal	44
3.7	Software history	44
4	Accessories	45
4.1	Accessories for Liquiport 2010 CSP44	45
4.2	Measuring cable	45
4.3	Sensors	46
5	Spare parts	48
	Index	50

1 Maintenance



Warning!

Process pressure and temperature, contamination, electrical voltage

Danger! Risk of serious or fatal injury!

- De-energize the device and disconnect the battery.
- If a sensor has to be removed during maintenance work, avoid hazards posed by pressure, temperature and contamination.



Caution!

Electrostatic discharge (ESD)

Risk of damaging the electronic components!

- For your own safety, only use genuine spare parts. With genuine parts, the function, accuracy and reliability are also ensured after maintenance work.
- Take personal protective measures to avoid ESD.

1.1 Recommended maintenance

Maintenance work has to be carried out at regular intervals to ensure the efficient operation of the sampler.

The maintenance work comprises:

- Replacing the wear parts
- Cleaning the device

The cleaning intervals depend heavily on:

- The medium
- The ambient conditions of the sampler (dust etc.)
- The programming intervals

For this reason, adapt the cleaning intervals to your specific requirements but always ensure that these cleaning tasks are performed regularly.

Replacing wear parts

Wear parts are replaced by Endress+Hauser Service at one- and two-year intervals. Please contact your local sales center in this regard.



Endress+Hauser offers its customers a maintenance contract. With a maintenance contract, you can increase your level of operational safety and relieve your operating staff of some of their workload. Ask your Endress+Hauser Service Organization for detailed information on maintenance contracts.

1.2 Replacing the pump tube



Warning!

Danger! Rotating parts!

- Take the sampler out of service before opening the peristaltic pump.
- Safeguard the sampler against accidental operation while working on the open peristaltic pump.

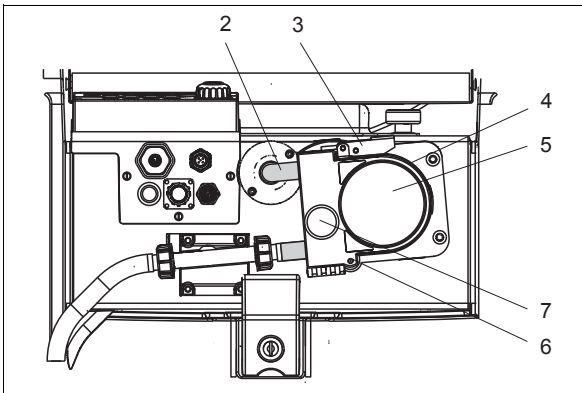

- 2 Pump tube
- 3 Fastening clip
- 4 Pump bracket
- 5 Pump head cover
- 6 Positioning pin
- 7 Knurled head screw

Fig. 1: Opening the peristaltic pump

a0014202

Open the peristaltic pump as follows:

1. Take the sampler out of service by pausing a program that is currently running.
2. Open the fastening clip (item 3) and push the pump bracket (item 4) upwards.
3. Remove the knurled head screw (item 7) and open the pump head cover (item 5) downwards.

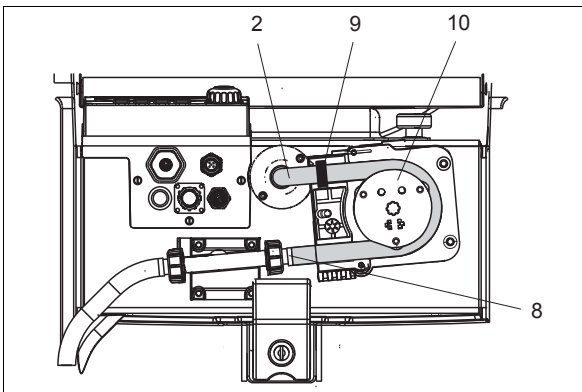



- 2 Pump tube
- 8 Clamp
- 9 Marking ring
- 10 Roller

Fig. 2: Replacing the pump tube

a0014203

1. Remove the clamp (item 8) and remove the pump tube (item 2) from the pump.
2. Remove any silicone deposits on the roller (item 10) and the flexible pump bracket.
3. Make sure the roller turns smoothly and evenly.
4. Apply some lubricant to the roller.
5. Secure the new pump tube to the pressure sensor with the clamp (item 8).
6. Guide the pump tube around the roller and insert the marking ring into the groove (item 9), →  2.
7. Close the pump head cover and screw it tight. Close the pump bracket.
8. Under Menu/Diagnostics/Term information/Pump tube life reset the tube life to zero by selecting "Reset".

 Calibrate the sample volume each time you replace a pump tube. → See Operating Instructions BA467C "Calibration".

 Caution!

Incorrect sample volume

Only reset the tube life counter to zero once you have successfully replaced the pump tube in order to avoid incorrect dosing of the medium.

1.3 Cleaning

1.3.1 Housing

Clean the housing with commercially available cleaning agents.

 Caution!

Danger of damaging the housing surface or housing seal!

Never use any of the following to clean the device:

- Concentrated mineral acids or bases
- Benzyl alcohol
- Methylene chloride
- Methanol
- Xylene
- Concentrated glycerol cleaner
- High-pressure steam

1.3.2 Wetted parts

- i** After cleaning, rinse all wetted parts thoroughly with clear water to ensure that all cleaning agent residue has been removed so it cannot affect subsequent medium samples.

Peristaltic pump

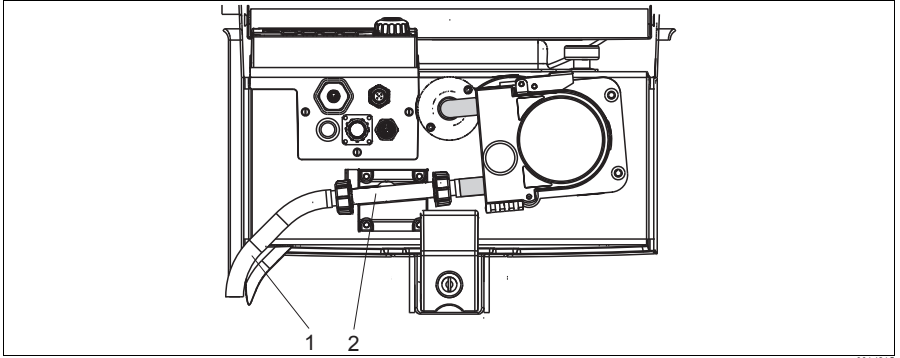

Fig. 3: Peristaltic pump

40014215

- 1 Suction line
2 Pressure sensor

Clean the wetted parts as follows:

1. Connect a container containing clear water to the suction line (item 1).
2. Remove the bottles from the sample compartment.
3. Rinse the wetted parts with clear water by taking a manual sample or by performing a pump test (under Menu/Diagnostics/Systemtest/Reset/Peristaltic pump -> Pump forward/Pump reverse).
4. Release the couplings to the left and right of the pressure sensor (item 2). Clean the tube piece carefully with a bottle brush.
5. Reconnect the sample supply to the tube connection and put the bottles back in the sample compartment.

Interior of peristaltic pump



Warning!

Danger! Rotating parts!

- Take the sampler out of service before opening the peristaltic pump.
- Safeguard the sampler against accidental operation while working on the open peristaltic pump.

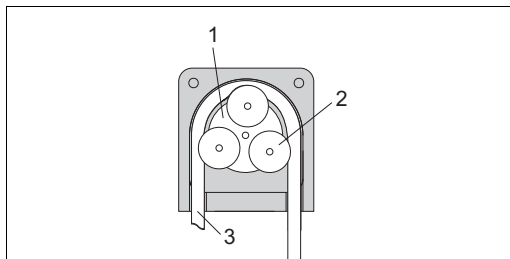

- 1 Pump rotor
- 2 Roller
- 3 Pump tube

Fig. 4: Interior view of the peristaltic pump

a0014029

1. Take the sampler out of service by pausing a program that is currently running.
2. Open the peristaltic pump as described in the "Replacing the pump tube" section.
3. Remove the pump tube.
4. Remove any silicone deposits on the roller and the flexible pump bracket.
5. Make sure the roller turns smoothly and evenly.

Cleaning the distribution arm

Clean the distribution arm as follows:

1. Screw off the distribution arm.
2. Clean these parts with water or soapsuds. Use a bottle brush if necessary.
3. Reinstall the cleaned distribution arm.

1.3.3 Sample compartment

The sample compartment has a fully integrated plastic inner lining.

Clean the sample compartment as follows:

1. Remove the bottles.
2. Spray-clean the sample compartment with a water hose.



You can wash the PE and glass bottles in a dishwasher at 60 °C.

1.3.4 Digital sensors (for version with sensors with the Memosens protocol)

1. If an error occurs or the maintenance schedule stipulates that the sensor has to be replaced, use a new sensor, or a sensor that has been precalibrated in the laboratory. A sensor is calibrated in the laboratory under optimum external conditions, thereby ensuring better quality of measurement.
2. Remove the sensor to be serviced and install the new sensor.
3. You must perform calibration if you use a sensor that is not precalibrated.
4. The sensor data are automatically accepted by the transmitter. A release code is not required.
5. Measurement is resumed.
6. Take the used sensor back to the laboratory. In the laboratory you can get the sensor ready for reuse while ensuring the availability of the measuring point.
 - Clean the sensor. For this purpose, use the cleaning agent specified in the sensor manual.
 - Inspect the sensor for cracks or other damage.
 - If no damage is found, regenerate the sensor. Where necessary, store the sensor in a regeneration solution (→ sensor manual).
 - Recalibrate the sensor for reuse.

1.3.5 Assemblies (for version with sensors with the Memosens protocol)

Refer to the assembly operating manual for information on servicing and troubleshooting the assembly. The assembly operating manual describes the procedure for mounting and disassembling the assembly, replacing the sensors and seals, and contains information on the material resistance properties, as well as on spare parts and accessories.

1.4 Calibration



All information on calibration is provided in BA467C "Calibration".

The position of the distribution arm is set at the factory.

The sample volume of the peristaltic pump is also calibrated at the factory.

For version with sensors with the Memosens protocol:

Users must decide whether the process conditions present require calibration during initial commissioning.

Additional calibration is not required in many standard applications.

Sensors with Memosens protocol are calibrated at the factory.

Calibrate the sensors at sensible intervals depending on the process.

1.5 Replacing the batteries

First remove the cover of the battery compartment to replace the batteries.



Warning!

If a power supply unit or a charger is connected, disconnect it from the mains.

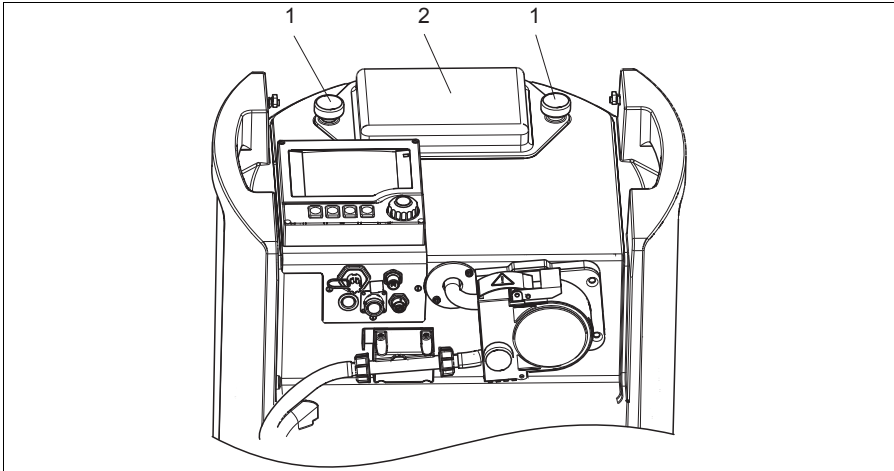

a0014207

Fig. 5: Cover of battery compartment

- 1 Screws
- 2 Cover of battery compartment

1. Release the screws (item 1).
2. Remove the cover of the battery compartment (item 2).
3. Remove the old batteries and disconnect them.
4. Connect the new batteries. Make sure the polarity is correct.
5. Place the new batteries into the battery compartment and replace the battery compartment cover.



Batteries must be replaced every 3 years by the following type of battery:
Panasonic LC-R127R2PG1.

2 Diagnostics menu

The Diagnostics menu contains all the information on the device status. Furthermore, various service functions are available.

The following messages are directly displayed every time you enter the menu:

- "Most important message"
Diagnostics message recorded with the highest criticality level
- "Last message"
Last diagnostics message recorded

All the other functions in the Diagnostics menu are described in the following chapters.

Diagnostics messages associated with sampling are deleted under the following conditions:

- Diagnostics messages caused by sampling are deleted automatically with the next successful sampling.
- Diagnostics messages caused by the level of medium in the bottle are deleted the next time the program is started.

2.1 Diagnostics list

All the current diagnostics messages are listed here.

A time stamp is available for each message. Furthermore, the system also displays the configuration and description of the message as saved in "Menu/Setup/General settings/Diagnostics/Device behavior".

For this purpose, select the appropriate message and press the navigator.

2.2 Logbooks

Types of logbooks

- Logbooks physically available (all apart from the overall logbook)
- Database view of all logbooks (=overall logbook)

Logbook	Visible in	Max. entries	Can be disabled ¹⁾	Logbook can be deleted	Entries can be deleted	Can be exported
Program logbook	Program logbook	5000	Yes	No	Yes	Yes
Overall logbook	All events	1000	Yes	No	Yes	No
Diagnostics logbook	Diagnostic events	250	(Yes)	No	Yes	Yes
Calibration logbook	Calibration events	75	(Yes)	No	Yes	Yes
Operation logbook	Configuration events	250	(Yes)	No	Yes	Yes
Version logbook	All events	50	No	No	No	Yes
Hardware version logbook	All events	125	No	No	No	Yes
Data logbook	Data logbooks	150,000	Yes	Yes	Yes	Yes



Logbook	Visible in	Max. entries	Can be disabled ¹⁾	Logbook can be deleted	Entries can be deleted	Can be exported
Debugging logbook	Only accessible with the special activation code (Service)	1000	Yes	No	Yes	Yes

1) Data in brackets means this depends on the overall logbook

Diagnostics/Logbooks

Function	Options	Info
▶ Program logbook		Chronological list of the programming events.
▶ Show	Events are displayed	Select a particular event to display more detailed information.
▶ Go to date	User input <ul style="list-style-type: none"> ■ Go to date ■ Time 	Use this function to go directly to a specific time in the list. In this way, you avoid having to scroll through all the information. The complete list is always visible, however.
▷ Delete all entries	Action	You can delete all the program logbook entries here.
▶ All events		Chronological list of all the logbook entries, with information on the type of event.
▶ Show	Events are displayed	Select a particular event to display more detailed information.
▶ Go to date	User input <ul style="list-style-type: none"> ■ Go to date ■ Time 	Use this function to go directly to a specific time in the list. In this way, you avoid having to scroll through all the information. The complete list is always visible, however.
▶ Calibration events		Chronological list of the calibration events.
▶ Show	Events are displayed	Select a particular event to display more detailed information.
▶ Go to date	User input <ul style="list-style-type: none"> ■ Go to date ■ Time 	Use this function to go directly to a specific time in the list. In this way, you avoid having to scroll through all the information. The complete list is always visible, however.
▷ Delete all entries	Action	You can delete all the calibration logbook entries here.
▶ Configuration events		Chronological list of the configuration events.
▶ Show	Events are displayed	Select a particular event to display more detailed information.

Diagnostics/Logbooks

Function	Options	Info
▶ Go to date	User input <ul style="list-style-type: none"> ■ Go to date ■ Time 	Use this function to go directly to a specific time in the list. In this way, you avoid having to scroll through all the information. The complete list is always visible, however.
▷ Delete all entries	Action	You can delete all the calibration logbook entries here.
▶ Diagnostic events		Chronological list of the diagnostics events.
▶ Show	Events are displayed	Select a particular event to display more detailed information.
▶ Go to date	User input <ul style="list-style-type: none"> ■ Go to date ■ Time 	Use this function to go directly to a specific time in the list. In this way, you avoid having to scroll through all the information. The complete list is always visible, however.
▷ Delete all entries	Action	You can delete all the calibration logbook entries here.
▶ Data logbooks		Chronological list of the data logbook entries.
▶ Show	Events are displayed	Select a particular event to display more detailed information.
▶ Go to date	User input <ul style="list-style-type: none"> ■ Go to date ■ Time 	Use this function to go directly to a specific time in the list. In this way, you avoid having to scroll through all the information. The complete list is always visible, however.
▷ Delete all entries	Action	You can delete all the calibration logbook entries here.
▶ Save logbooks		
File format	Options <ul style="list-style-type: none"> ■ CSV ■ FDM 	Save the logbook in the preferred file format.  The FDM format allows you to transmit data to the PC in such a way that they cannot be tampered with.
	Options ▷ <ul style="list-style-type: none"> ■ Program logbook ■ All event logbooks ■ Calibration logbook ■ Diagnostic logbook ■ Configuration logbook ■ HW version logbook ■ Version logbook 	Use this function to save the logbook to an SD card. You can then open the file you saved (.csv/.fdm) on the PC and process it in MS-Excel for example. Insert the SD card into the controller card reader and select the logbook to be saved.
 The file name is made up of the "Logbook ident" (Menu/Setup/General settings/Logbooks), an abbreviation for the particular logbook and a time stamp.		

2.3 System information

Diagnostics/System information

Function	Options	Info
Device tag	Read only	Individual device tag, -> "General settings"
Order code	Read only	You can order identical hardware with this code. This code changes on account of changes to the hardware and you can enter the new code you received from the manufacturer here ¹⁾ .  To find out what device version you have, enter the order code in the search screen at the following address: www.products.endress.com/order-ident
Order code extended	Read only	Complete order code resulting from the product structure. This code changes on account of changes to the hardware and you can enter the new code here.
Serial number	Read only	The serial number allows you to access device data and documentation on the Internet: www.products.endress.com/device-viewer
Software version	Read only	Current version
Sw version FMSY1	Read only	Current version
FMSY1-proj. version	Read only	Current version
ENP version	Read only	Version of the electronic nameplate
▶ System modules		
Depends on the electronics module available, e.g.: Base	Read only <ul style="list-style-type: none"> ■ Description ■ Serial number ■ Order code ■ Hardware version ■ Software version 	This information is provided for every electronics module available. Specify the serial numbers and order codes when servicing, for example.
▶ Sensors		
Depends on the sensors connected	Read only <ul style="list-style-type: none"> ■ Description ■ Serial number ■ Order code ■ Hardware version ■ Software version 	This information is provided for every sensor available. Specify the serial numbers and order codes when servicing, for example.

1) Provided you give the manufacturer all the information about changes to the hardware.

2.4 Status of inputs/outputs

The following measured values are listed (read only):

- Binary inputs
 - Current function state: on or off
- Current inputs
 - Actual current values of all the current inputs available
- Binary outputs
 - Current function state: on or off
- Temperature sensors
 - Current value is displayed:
- Current outputs (for version with sensors with the Memosens protocol)
 - Actual current values of the current outputs

2.5 Systemtest/Reset

Diagnostics/Systemtest/Reset

Function	Options	Info
Power supply	Read only	The current supply voltage is displayed.
▶ Manual sampling		
Bottle configuration	Read only	
Bottle volume	Read only	
Distributor position	Options <ul style="list-style-type: none"> ■ Bottle 1 ... 	Select which bottle should be filled with the sample.
Sample volume	10 to 10000 ml Factory setting 100 ml	You can change the sample volume.
▷ Start sampling	Action	
▶ Peristaltic pump		
▷ Pump forward	Action	
Pump function forward, to stop press ESC	Read only	
Current pump run time	Read only	
Power supply	Read only	The current supply voltage is displayed. With AC power supply: 24 V ±0.5 V With DC power supply: 22 to 28 V
Current	Read only	The current consumption of the pump is displayed.
Vacuum	Read only	The vacuum is an indicator of the suction height. -> 100 mbar is equivalent to a suction height of approx. 1 m.

Diagnostics/Systemtest/Reset

Function	Options	Info
Probe detected	Read only	Yes: the medium was detected No: no medium was detected
▷ Pump reverse	Action	
Pump function reverse, to stop press ESC	Read only	
Current pump run time	Read only	
Power supply	Read only	The current supply voltage is displayed. With AC power supply: 24 V ±0.5 V With DC power supply: 22 to 28 V
Current	Read only	The current consumption of the pump is displayed.
Vacuum	Read only	The vacuum is an indicator of the suction height. -> 100 mbar is equivalent to a suction height of approx. 1 m.
Probe detected	Read only	Yes: the medium was detected No: no medium was detected
▷ Distribution arm	Action	Only for bottle configurations with more than one bottle.
Test distribution arm	Read only	When the menu item is activated, the distribution arm undergoes a test run. Afterwards, the system moves to each position in succession and the position is displayed.
Position	Read only	In the case of plate distribution, the arm moves left and right to ensure the bottles are numbered consecutively.  Calibrate the distribution arm if the arm is not positioned precisely over the bottles.
▷ Device Reset	Options ■ OK ■ ESC	Restart and keep all the settings
▷ Factory default	Options ■ OK ■ ESC	Restart with factory settings Settings that have not been saved are lost.

2.6 Sensor change (for version with sensors with the Memosens protocol)

Diagnostics/Sensor change

Function	Options	Info
List of channels	Options <ul style="list-style-type: none"> ■ On ■ Off Factory setting Off	If you set the function to "On", the measured value at the current output is set to hold. In this way you avoid an error being reported at the process control system if the sensor is replaced on site. You can set the hold individually for every Memosens channel. Alternatively, you can set all the Memosens channels simultaneously to hold, or cancel the hold.
▷ All channels sensor change on	Action	Once you have replaced the sensor, you have to disable the hold at the same point.
▷ All channels sensor change off	Action	

2.7 Manual hold (for version with sensors with the Memosens protocol)

Diagnostics/Manual hold

Function	Options	Info
List of channels	Options <ul style="list-style-type: none"> ■ On ■ Off Factory setting Off	If you set the function to "On", the measured value at the current output is set to hold. You can set the hold individually for every Memosens channel. Alternatively, you can set all the Memosens channels simultaneously to hold, or cancel the hold.
▷ All channels manual hold on	Action	Once you have completed the maintenance task, you have to disable the hold at the same point.
▷ All channels manual hold off	Action	

2.8 Term information

The following information is displayed:

- **Operating hours device:**
Displays the total operating hours of the device in days, hours and minutes
- **Sample totalizer:**
Number of all samples taken and sample errors
- **Pump tube life:**
Displays how old the tube is in days, hours and minutes
 This counter must be reset when a tube is replaced.

Set the specific counter reading to zero with "Reset".

2.9 Simulation

You can simulate values at inputs and outputs for testing purposes:

- Current values at current outputs
- Measured values at inputs

 Only current values are simulated. It is not possible to use the simulation function to calculate the totalized value for the flow or rainfall.

2.10 Sensor information (for version with sensors with the Memosens protocol)

Select the channel you want from the list of channels.

Information in the following categories is displayed:

- Operating time
 - Sensor operation under extreme conditions
- Calibration
 - Calibration data of the last calibration
- Sensor specifications
 - Measuring range limits for main measured value and temperature
- General information
 - Sensor identification information

The specific data that are displayed depends on what sensor is connected.

3 Troubleshooting

3.1 Troubleshooting

The sampler continuously monitors its own functions.

The color of the display background changes to red if a diagnostics message for error category "F" occurs.

The LED beside the display flashes red if a diagnostics message for error category "M" occurs.

3.2 System error messages

i System error messages are the controller diagnostics messages that are output on the display or via the current output.

1. See the Diagnostics menu for details on the error message. Follow the instructions to rectify the problem.
2. If this does not help:
 - a. Using the message number shown on the display, locate the diagnostics message in the error tables in this manual. Ignore the letters indicating the Namur error category.
 - b. Follow the troubleshooting instructions provided in the last column of the error tables.
3. Contact the Service Department if you cannot rectify the error yourself. Only cite the error number.

3.2.1 Classification of diagnostics messages

More detailed information on the current diagnostics messages displayed is provided in the DIAG/Diagnostics list menu.

In accordance with Namur specification NE 107, the diagnostics messages are characterized by:

- Message number
- Error category (letter in front of the message number)
 - F = Failure. A malfunction has been detected.
The cause of the malfunction is to be found in the sampling point/measuring point. Any controller connected should be set to manual mode.
 - M = Maintenance required. Action may have to be taken soon.
The device still measures/takes a sample correctly. Immediate measures must not be taken. However, proper maintenance efforts would prevent a possible malfunction in the future.
 - C = Function check. (No error)
Maintenance work is being performed on the device. Wait until the work has been completed.
 - S = Out of specification. The measuring point is being operated outside specifications.
Operation is still possible. However, you run the risk of increased wear, shorter operating life or lower accuracy levels. The cause of the problem is to be found outside the measuring point.
- Message text

i If you contact the Service Department, please cite the message number only. Since you can individually change the assignment of an error to an error category, the Service Department cannot use this information.

3.2.2 Adjusting the device behavior

All the diagnostics messages are assigned to specific error categories at the factory. Since other settings might be preferred depending on the application, error categories and the effect errors have on the measuring point can be configured individually. Furthermore, every diagnostics message can be disabled.

Example

The controller returns diagnostics message 531 "Logbook full". You want to change this message so that an error is not indicated on the display for example.

1. Go to:
 - Menu/Setup/General settings/Diagnostics/Device behavior for device-specific diagnostics messages (as in this example)
 - Menu/Setup/Inputs/.../Diag. settings/Diag. behavior for sensor-specific diagnostics messages.
2. Select the diagnostics message and press the navigator button.
3. Decide:
 - a. Should the message be deactivated?
 - b. Do you want to change the error category?
 - c. Should an error current be output?
 - d. Do you want to trigger a cleaning program?
4. Deactivate the message, for example (Diagnostics message to "Off").

Configuration options

 This branch, along with the same functions, can be found in various parts of the menu. The list of diagnostic messages displayed depends on the path selected. There are device-specific messages, and messages that depend on what sensor is connected.

Paths: Menu/Setup/General settings/Diagnostics or Menu/Setup/Inputs/Diag. settings/Diag. behavior (optional)

Function	Options	Info
List of diagnostic messages		Select the message to be changed.
Diagnostic message	Options <ul style="list-style-type: none"> ■ On ■ Off Factory setting Depends on the message	You can deactivate or reactivate a diagnostic message here. Deactivating means: <ul style="list-style-type: none"> ■ No error message in the measuring mode ■ No error current at the current output
Error class	Options <ul style="list-style-type: none"> ■ Maintenance (M) ■ Out of specification (S) ■ Function check (C) ■ Failure (F) Factory setting Depends on the message	The messages are divided into different error categories in accordance with NAMUR NE 107. → BA470C "Maintenance & diagnostics"

**Paths: Menu/Setup/General settings/Diagnostics or
Menu/Setup/Inputs/Diag. settings/Diag. behavior (optional)**

Function	Options	Info
Error current	Options <ul style="list-style-type: none"> ■ On ■ Off Factory setting Depends on the message	Decide whether an error current should be output at the current output if the diagnostic message display is activated.
Diag. output	Options <ul style="list-style-type: none"> ■ None ■ Binary output Factory setting None	You can use this function to select a binary output to which the diagnostic message should be assigned. For sensors with the Memosens protocol: You first have to configure a relay output before being able to assign the message to an output (Menu/Setup/Outputs, assign "Diagnostics" function and set Operating mode to "Normal"). → BA464C "Operation & configuration"
Cleaning program (optional)	Options <ul style="list-style-type: none"> ■ None ■ Cleaning 1 ■ Cleaning 2 ■ Cleaning 3 ■ Cleaning 4 Factory setting None	Decide whether the diagnostic message should trigger a cleaning program. You can define the cleaning programs under: Menu/Setup/Additional functions/Cleaning.
Detail information	Read only	Here you can find more information on the diagnostic message and instructions on how to resolve the problem.

3.2.3 Device-specific, general diagnostics messages

No.	Message	Factory settings			Tests or remedial measures
		Cat.	Diag. on/off	Error current	
202	Selftest active	C	On	Off	Wait for self-test to be finished
216	Hold active	C	On	Off	Output values and status of the channel are on hold
241	Internal error	F	On	On	Internal device error 1. Update the software 2. Contact the Service Department 3. Replace the backplane (E+H Service)
242	Software incomp.	F	On	On	
243	Internal error	F	On	On	
261	Electr. module	F	On	On	Electronics module defective 1. Replace the module 2. Contact the Service Department

No.	Message	Factory settings			Tests or remedial measures
		Cat.	Diag. on/off	Error current	
262	Module connect.	F	On	On	Electronics module not communicating 1. Check cable connection, replace if necessary 2. Check the power supply of the sampling control module 3. Contact the Service Department
263	Electr. module	F	On	On	Wrong kind of electronics module 1. Replace the module 2. Contact the Service Department
284	Firmware update	M	On	Off	Update completed successfully
285	Update error	F	On	On	Firmware update failed 1. Repeat update 2. SD card error → use another card 3. Incorrect firmware → repeat with suitable firmware 4. Contact the Service Department
302	Battery low	M	On	Off	Buffer battery of real time clock is low The date and time are lost if the power is interrupted. → Contact the Service Department (battery replacement)
304	Module data	F	On	On	At least 1 module has incorrect configuration data 1. Check the system information 2. Contact the Service Department
305	Powerconsumption	F	On	On	Total power consumption too high 1. Check installation 2. Remove sensors/modules
306	Software	F	On	On	Internal firmware error → Contact the Service Department
311	Temp. sensor	F	On	On	Sensor for sample temperature regulation 1. Check the sensor has been fitted correctly 2. Replace sensor
314	No sample	F	On	On	No inflow of sample → Check pump tube for leaks
322	Read subprogram	F	On	On	Selected subprogram cannot be read from the program memory → Create new subprogram
323	Write subprg.	F	On	On	Subprogram created cannot be saved → Reset the software
324	Delete subprg.	F	On	On	Selected subprogram cannot be deleted from the program memory → Reset the software

No.	Message	Factory settings			Tests or remedial measures
		Cat.	Diag. on/off	Error current	
325	Read subprg. list	F	On	On	Subprogram list cannot be read from the program memory → Reset the software
328	Distribution arm	F	On	On	Distribution arm zero point not found 1. Perform distribution arm test 2. Contact the Service Department
331	Peristaltic pump	F	On	On	Peristaltic pump defective → Contact the Service Department
332	Peristaltic pump	F	On	On	Control of peristaltic pump defective → Contact the Service Department
333	Liquid detector	F	On	On	Pressure sensor defective → Contact the Service Department
337	Pump tubing	M	On	Off	Pump tube operating time reached shortly – Default values from diagnostic settings are displayed
338	Pump tubing	M	On	Off	Pump tube operating time reached – Default values from diagnostic settings are displayed → Change the pump tubing
343	Power supply	M	On	Off	Power supply failure
344	Program pause	C	On	Off	Sampling program paused
345	Time changeover	M	On	Off	Daylight saving time/winter time setting Normal time (winter time) active.
346	Time changeover	M	On	Off	Daylight saving time/winter time setting Daylight saving time active
347	Sampling	F	On	On	Sampling command not processed 1. Check internal connection 2. Reset the software
348	Read program	F	On	On	Selected program cannot be read from the program memory → Create new program
349	Write program	F	On	On	Program created cannot be saved Hardware error has occurred → Contact the Service Department
350	Module connect.	F	On	On	Cannot communicate with internal module FMSY1 → Check internal connecting cable
351	Delete program	F	On	On	Selected program cannot be deleted from the program memory → Reset the software

No.	Message	Factory settings			Tests or remedial measures
		Cat.	Diag. on/off	Error current	
352	Read prog. list	F	On	On	Program list cannot be read from the program memory → Reset the software
353	Overfill check	M	On	Off	Total capacity of bottle reached ■ No further sampling to current bottle is triggered
354	Bottle check	M	On	Off	No empty bottles available for current program ■ No further sampling
355	Start time over	M	On	Off	Start time entered is in the past ■ Enter a new start time
356	Overfill check	S	On	Off	Volume of sample does not fit in the sample bottle → Change the sample volume
357	No sampling	M	On	Off	Too many events at the current sampling time; up to 24 sampling events can be triggered simultaneously → Change the program settings so that samples are taken at different times
358	Configuration	F	On	On	Program configuration does not match the current device configuration → Adjust the configuration
360	No sample	F	On	On	Intake hose blocked → Clean or replace the hose
361	Analog input	F	On	On	Current at analog input S:1 or S:2 too low 1. Check current loop for error current 2. Contact the Service Department
401	Reset to default	F	On	On	Factory reset is performed
406	Param. active	C	On	Off	→ Wait for configuration to be finished
407	Diag. active	C	Off	Off	→ Wait for maintenance to be finished
412	Writing backup	M	On	Off	→ Wait for the write process to be finished
413	Reading backup	C	On	Off	→ Wait
460	Curr. under-run	F	On	On	Reasons ■ Sensor in air ■ Air pockets in assembly ■ Sensor fouled ■ Incorrect flow to sensor
461	Current overrun	F	On	On	Measures 1. Check sensor installation 2. Clean sensor 3. Adjust assignment of current outputs
502	No text catalog	F	On	On	→ Contact the Service Department

No.	Message	Factory settings			Tests or remedial measures
		Cat.	Diag. on/off	Error current	
503	Language change	M	On	Off	Language change failed → Contact the Service Department
530	Logbook at 80%	M	On	Off	1. Save the logbook to the SD card and then delete the logbook in the device 2. Set memory to ring memory 3. Deactivate logbook
531	Logbook full	M	On	Off	
532	License error	M	On	Off	→ Contact the Service Department
963	Parameter save	M	On	Off	Configuration saving has failed, → repeat
965	Parameter load	M	On	Off	Configuration successfully loaded
966	Parameter load	M	On	Off	Configuration loading has failed, → repeat
967	Parameter load	M	On	Off	Configuration loading aborted
969	Parameter reset	M	On	Off	Factory default successful
971	Parameter reset	M	On	Off	Factory default failed
972	Current > 20 mA	M	On	Off	Current output range exceeded
973	Current < 4 mA	M	On	Off	Current output range undershot
974	Diag. confirmed	C	Off	Off	User has acknowledged the message displayed in the measuring menu.

3.2.4 Sensor-specific diagnostics messages

Abbreviations used for sensor types

- P ... pH/ORP (general)
 - P (glass) ... glass electrode
 - P (ISFET) ... ISFET sensor
- C ... Conductivity (general)
 - C (cond.) ... Conductive sensor
 - C (ind.) ... Inductive sensor
- O ... Oxygen (general)
 - O (opt.) ... Optical sensor
 - O (amp.) ... Amperometric sensor
- N ... Nitrate
- T ... Turbidity and solids

No.	Message	Factory settings			Sensor type	Tests or remedial measures
		Cat.	Diag.	Error current		
002	Sensor unknown	F	On	On	All	Replace sensor
004	Sensor problem	F	On	On	All	
005	Sensordata	F	On	On	All	
010	Sensor init.	F	On	On	All	Wait for initialization to be finished
012	Writing data	F	On	On	All	Could not write sensor data 1. Repeat write process 2. Replace sensor
013	Sensor type	F	On	On	All	Replace sensor, making sure correct sensor type is used
018	Sensor not ready	F	On	On	All	Sensor communication blocked 1. Sensor fails tag check. Replace. 2. Internal software error. Contact Service Department
022	Temp. sensor	F	On	On	P, C, O	Temperature sensor defective Replace sensor
061	Sensor electr.	F	On	On	All	Sensor electronics defective Replace sensor
062	Sensor connect.	F	On	On	All	1. Check sensor connection 2. Contact the Service Department
063	Sensor check	F	On	On	P, C	Poor sensor power supply 1. Check sensor connection 2. Replace sensor
081	Initialization	F	On	On	All	Wait for initialization to be finished
100	Sensor comm.	F	On	On	All	Sensor not communicating 1. Check sensor connection 2. Check sensor plug 3. Contact the Service Department
101	Sensor type	F	On	On	All	1. Replace sensor 2. Contact the Service Department
102	Sensor check	M	On	Off	All	Calibration interval elapsed. Measurement can still take place. Calibrate sensor
103	Sensor check	M	On	Off	All	Calibration interval will elapse soon. Measurement can still take place. Calibrate sensor
104	Sensor check	M	On	Off	All	Validity of last calibration expired. Measurement can still take place. Calibrate sensor

No.	Message	Factory settings			Sensor type	Tests or remedial measures
		Cat.	Diag.	Error current		
105	Sensor check	M	On	Off	All	Validity of last calibration will expire soon. Measurement can still take place. Calibrate sensor
106	Sensor TAG	F	On	On	All	Sensor has invalid tag or tag group 1. Replace sensor 2. Use new sensor with identical design 3. Deactivate tag check
107	Calib. active	C	On	Off	P, C, O	Wait for calibration to be finished
108	Sensor check	M	On	Off	P, C, O	Specified number of sterilizations will soon be reached. Measurement can still take place. Replace sensor
109	Sensor check	M	On	Off	O (amp.)	Specified number of sterilizations for the cap is reached. Measurement can still take place. Replace membrane cap
114	Temp. offs. high	M	On	Off	All	Calibration alarm: Limit values for temperature offset exceeded 1. Check temperature sensor 2. Replace sensor
115	Temp. offset low	M	On	Off	All	
116	Temp. Calib	M	On	Off	All	Calibration alarm: Limit values for temperature slope exceeded Sensor old or defective 1. Repeat calibration 2. Replace sensor
117	Temp. slope low	M	On	Off	All	
118	Sensor glass	F	On	On	P (glass)	Glass breakage warning, impedance of pH glass too low Measuring can continue until the alarm (118) occurs. 1. Inspect sensor for hair-line cracks and breakage 2. Check medium temperature 3. Replace sensor
119	Sensor glass	M	On	Off	P (glass)	
120	Sensor reference	F	On	On	P (glass)	Reference warning, impedance of reference too low Measuring can continue until the alarm (120) occurs 1. Check reference for clogging/contamination 2. Clean reference/junction 3. Replace sensor
121	Sensor reference	M	On	Off	P (glass)	

No.	Message	Factory settings			Sensor type	Tests or remedial measures
		Cat.	Diag.	Error current		
122	Sensor glass	F	On	On	P (glass)	Impedance limit values exceeded/undershot Measuring can continue until the alarm (122, 124) occurs. 1. Inspect sensor for hair-line cracks and breakage 2. Check limit values and change where necessary 3. Replace sensor
123	Sensor glass	F	On	On	P (glass)	
124	Sensor glass	M	On	Off	P (glass)	
125	Sensor glass	F	On	On	P (glass)	
126	Sensor check	M	On	Off	P (glass)	Sensor condition check (SCC), poor sensor condition Glass membrane fouled or dry, junction blocked 1. Clean sensor, regenerate 2. Replace sensor
127	Sensor check	M	On	Off	P (glass)	Sensor condition check (SCC), adequate sensor condition
128	Sensor leakage	F	On	On	P (ISFET)	ISFET leak current alarm Defective due to gate abrasion or damage Replace sensor
129	Sensor leakage	F	On	Off	P (ISFET)	ISFET leak current warning Measuring can continue until the alarm occurs
130	Sensor check	F	On	On	P, O	Poor sensor power supply 1. Check sensor connection 2. Replace sensor
131	Sensor check	M	On	Off	O (opt.)	Limit values for sensor relaxation time (fluorescence decay time) exceeded/undershot Reasons: high oxygen content, incorrect calibration 1. Repeat calibration 2. Replace sensor cap 3. Replace sensor
132	Sensor check	M	On	Off	O (opt.)	
133	Sensor check	F	On	On	O (opt.)	No signal (fluorescence decay) 1. Replace sensor cap 2. Contact the Service Department
134	Sensor check	M	On	Off	O (opt.)	Low signal amplitude. Measurement can still take place. 1. Replace sensor cap 2. Contact the Service Department
135	Sensor check	F	On	On	O	Temperature outside specification 1. Check process 2. Check installation
136	Sensor check	F	On	On	O	

No.	Message	Factory settings			Sensor type	Tests or remedial measures
		Cat.	Diag.	Error current		
137	Sensor check	F	On	On	O (opt.)	Sensor LED: no voltage Contact the Service Department
138	Sensor check	F	On	On	O (opt.)	Sensor LED: no power Contact the Service Department
140	Sensor check	F	On	On	O	Sensor range errors Contact the Service Department
141	Sensor check	F	On	On	C (cond.)	Polarization warning The measured value is distorted at high conductivity levels. Use a sensor with a larger cell constant
142	Sensor check	F	On	On	C	No conductivity displayed Reasons: sensor in air, sensor defective 1. Check installation 2. Replace sensor
143	Sensor check	F	On	On	C	Sensor self-test error 1. Replace sensor 2. Contact the Service Department
144	Cond. out of rng	F	On	On	C	Conductivity outside measuring range Use a sensor with a suitable cell constant
145	Delta slope al	F	On	On	P, O	Large change in slope compared to last calibration. Measurement can still take place. 1. Check sensor, replace if necessary 2. Replace calibration solution 3. Repeat calibration
146	Sensor temp.	S	On	Off	C, N, T	Temperature outside specification 1. Check temperature 2. Check measuring chain 3. Replace sensor type
147	Sensor check	F	On	On	C (ind.)	Coil transmission current too high Reasons: transmission coil short-circuit, inductance too low 1. Replace sensor 2. Contact the Service Department
148	Sensor check	F	On	On	C (ind.)	Coil transmission current too low Reasons: transmission coil interrupted, inductance too high 1. Replace sensor 2. Contact the Service Department
152	Sensor data	F	On	On	C (ind.)	No calibration data Perform air set calibration

No.	Message	Factory settings			Sensor type	Tests or remedial measures
		Cat.	Diag.	Error current		
153	Sensor failure	F	On	On	N	Sensor strobe lamp defective Reasons: deterioration, end of operating life, mechanical interference/vibration 1. Replace sensor 2. Contact the Service Department
154	Calibration	M	On	Off	C	Factory calibration is used Perform calibration
155	Sensor failure	F	On	On	N, T	Sensor failure Error with analog evaluation 1. Replace sensor 2. Contact the Service Department
156	organ. pollution	F	On	On	N, T	Excessive organic fouling Reasons: sensor fouling, high organic content, incorrect orientation 1. Clean sensor 2. Install automatic cleaning 3. Check application
157	Filter change	M	On	Off	N	Optical filter must be replaced Reasons: long period of operation, moisture in sensor 1. Replace sensor 2. Contact the Service Department
158	Sensor check	F	On	On	N, T	Invalid measured value 1. Check sensor power supply 2. Restart device 3. Contact the Service Department
159	Sensor check	F	On	On	N, T	Uncertain measured value Reasons: sensor fouling, incorrect application 1. Clean sensor 2. Check application
160	Sensor check	F	On	On	N, T	No calibration data Reasons: data deleted 1. Select other data record 2. Use factory calibration 3. Contact the Service Department
162	Install.factor	F	On	On	C (ind.)	Installation factor exceeded/undershot, alarm Reason: distance between wall and sensor too small (< 15 mm) 1. Check pipe diameter 2. Clean sensor 3. Calibrate sensor
163	Install.factor	F	On	On	C (ind.)	
168	Sensor check	M	On	Off	C (cond.)	Polarization warning The measured value is distorted at high conductivity levels. Use a sensor with a larger cell constant

No.	Message	Factory settings			Sensor type	Tests or remedial measures
		Cat.	Diag.	Error current		
179 - 199:						
Warning issued by hours of operation monitoring system. Measurement can still take place.						
1. Replace sensor						
2. Adjust monitoring limit						
3. Deactivate monitoring						
179	Operating time	M	On	Off	P	Operating hours > 300 mV
180	Operating time	M	On	Off	P	Operating hours < -300 mV
181	Operating time	M	On	Off	O (opt.)	Operating hours < 25 µS
182	Operating time	M	On	Off	O (opt.)	Operating hours > 40 µS
183	Operating time	M	On	Off	O (amp.)	Operating hours > 10 nA (COS51D)
184	Operating time	M	On	Off	O (amp.)	Operating hours > 30 nA (COS22D)
185	Operating time	M	On	Off	O (amp.)	Operating hours > 40 nA (COS51D)
186	Operating time	M	On	Off	O (amp.)	Operating hours > 160 nA (COS22D)
187	Operating time	M	On	Off	C	Operating hours > 80 °C, 100 nS/cm
188	Operating time	M	On	Off	C, O	Operating hours < 5 °C
189	Operating time	M	On	Off	O	Operating hours > 5 °C
190	Operating time	M	On	Off	O	Operating hours > 25 °C
191	Operating time	M	On	Off	O	Operating hours > 30 °C
192	Operating time	M	On	Off	O	Operating hours > 40 °C
193	Operating time	M	On	Off	P, C, O	Operating hours > 80 °C
194	Operating time	M	On	Off	P	Operating hours > 100 °C
195	Operating time	M	On	Off	C	Operating hours > 120 °C
196	Operating time	M	On	Off	C	Operating hours > 125 °C
197	Operating time	M	On	Off	C	Operating hours > 140 °C
198	Operating time	M	On	Off	C	Operating hours > 150 °C
199	Operating time	M	On	Off	P, O, N, T	Total operating hours
215	Simul. active	C	On	Off	All	Simulation active End simulation by changing to measuring mode
408	Calib. aborted	M	Off	Off	P, C, O	Calibration aborted

No.	Message	Factory settings			Sensor type	Tests or remedial measures
		Cat.	Diag.	Error current		
500	Sensor calib.	M	On	Off	All	Calibration aborted, main measured value fluctuates Reasons: sensor too old, sensor occasionally dry, calibration value not constant 1. Check sensor 2. Check calibration solution
501	Sensor calib.	M	On	Off	All	Calibration aborted, temperature measured value fluctuates Reasons: sensor too old, sensor occasionally dry, temperature of calibration solution not constant 1. Check sensor 2. Regulate calibration solution temperature
504 - 522: Limit values of calibration monitoring system exceeded/undershot. Measuring can continue if a warning is issued. Possible reasons: sensor old or defective, reference blocked, calibration solution too old or contaminated 1. Check sensor, replace if necessary 2. Check calibration solution, replace if necessary 3. Repeat calibration						
504	Sensor calib.	F	On	On	P, O	Max. zero point alarm
505	Sensor calib.	M	On	Off	P, O	Max. zero point warning
506	Sensor calib.	F	On	On	P, O	Min. zero point alarm
507	Sensor calib.	M	On	Off	P, O	Min. zero point warning
508	Sensor calib.	F	On	On	P, O	Min. slope alarm
509	Sensor calib.	M	On	Off	P, O	Min. slope warning
510	Sensor calib.	F	On	On	P, O	Max. slope alarm
511	Sensor calib.	M	On	Off	P, O	Max. slope warning
512	Sensor calib.	F	On	On	O (amp.)	Zero point alarm
513	Zero Warn	M	On	Off	O (amp.)	Zero point warning
514	Sensor calib.	F	On	On	P (ISFET)	Max. operating point alarm
515	Sensor calib.	M	On	Off	P (ISFET)	Max. operating point warning
516	Sensor calib.	F	On	On	P (ISFET)	Min. operating point alarm
517	Sensor calib.	M	On	Off	P (ISFET)	Min. operating point warning
518	Sensor calib.	M	On	Off	P, O	Delta slope warning
519	Sensor calib.	F	On	On	P, O	Delta zero point alarm
520	Sensor calib.	M	On	Off	P, O	Delta zero point warning

No.	Message	Factory settings			Sensor type	Tests or remedial measures
		Cat.	Diag.	Error current		
521	Sensor calib.	F	On	On	P (ISFET)	Delta operating point alarm
522	Sensor calib.	M	On	Off	P (ISFET)	Delta operating point warning
523	Sensor calib.	F	On	On	C	Invalid cell constant, max./min. value or lower/upper alarm/warning value reached 1. Calibrate sensor 2. Replace sensor
524	Sensor calib.	F	On	On	C	
525	Sensor calib.	F	On	On	C	
526	Sensor calib.	M	On	Off	C	
527	Sensor calib.	F	On	On	C	
528	Sensor calib.	M	On	Off	C	
529	Sensor calib.	M	On	Off	O (amp.)	Specified number of cap calibrations soon reached Measurement can still take place. Replace sensor cap
832	Temp. range	S	On	Off	All	Outside temperature specification 1. Check application 2. Check temperature sensor
834	Process temp.	S	On	Off	All	Process temperature too high 1. Reduce temperature 2. Check measuring chain 3. Change sensor type
835	Process temp.	S	On	Off	All	Process temperature too low 1. Increase temperature 2. Check measuring chain 3. Change sensor type
841	Operating range	S	On	Off	All	Process value outside operational range 1. Check application 2. Check sensor
842	Process value	S	On	Off	All	Process limit value exceeded/undershot Reasons: sensor in air, air pockets in assembly, incorrect flow to sensor, sensor defective 1. Change process value 2. Check measuring chain 3. Change sensor type
843	Process value	S	On	Off	All	
904	Process check	F	On	On	All	Stagnating measuring signal Reasons: sensor in air, sensor fouling, incorrect flow to sensor, sensor defective 1. Check measuring chain 2. Check sensor 3. Restart device

No.	Message	Factory settings			Sensor type	Tests or remedial measures
		Cat.	Diag.	Error current		
934	Process temp.	S	On	Off	All	Process temperature high 1. Do not increase temperature 2. Check measuring chain 3. Change sensor type
935	Process temp.	S	On	Off	All	Process temperature low 1. Do not reduce temperature 2. Check measuring chain 3. Change sensor type
942	Process value	S	On	Off	All	Process value high 1. Do not increase process value 2. Check measuring chain 3. Change sensor type
943	Process value	S	On	Off	All	Process value low 1. Do not decrease process value 2. Check measuring chain 3. Change sensor type
Concentration table (conductivity):						
950	Process temp.	F	On	On	C	Process temperature below the lowest value in the table Extend table
951	Process temp.	F	On	On	C	Process temperature above the highest value in the table Extend table
952	Process conduc.	F	On	On	C	Process conductivity below the lowest value in the table Extend table
953	Process conduc.	F	On	On	C	Process conductivity above the highest value in the table Extend table
954	Process concent.	F	On	On	C	Process concentration below the lowest value in the table Extend table
955	Process concent.	F	On	On	C	Process concentration above the highest value in the table Extend table
Temperature compensation table (conductivity):						
956	Process temp.	F	On	On	C	Process temperature below the lowest value in the table Extend table
957	Process temp.	F	On	On	C	Process temperature above the highest value in the table Extend table

No.	Message	Factory settings			Sensor type	Tests or remedial measures
		Cat.	Diag.	Error current		
958	Process conduc.	F	On	On	C	Process conductivity below the lowest value in the table Extend table
959	Process conduc.	F	On	On	C	Process conductivity above the highest value in the table Extend table
960	Proc.cond.comp	F	On	On	C	Conductivity compensation below the lowest value in the table Extend table
961	Proc.cond.comp	F	On	On	C	Conductivity compensation above the highest value in the table Extend table

3.2.5 Configuration options for troubleshooting (for version with sensors with the Memosens protocol)

The table **only** lists the diagnostics messages that depend on your settings in the menu. The path where you can change the settings is specified in the table.

The sensor type is also indicated in the path if the message **only** applies to one type of sensor. All other settings affect several sensor types.

No.	Path to software function
102	Menu/Setup/Inputs/Calib. settings/Calibration timer
103	Menu/Setup/Inputs/Calib. settings/Calibration timer/Calibration timer
104	Menu/Setup/Inputs/Calib. settings/Calib. expiration date/Alarm limit
105	Menu/Setup/Inputs/Calib. settings/Calib. expiration date/Warning limit
108	Menu/Setup/Inputs/Diag. settings/Sterilizations/Warning limit
109	Menu/Setup/Inputs/Oxygen (amp.)/Diag. settings/Cap sterilisations/Warning limit
122	Menu/Setup/Inputs/pH Glass/Diag. settings/Glass impedance (SCS)/Lower alarm limit
123	Menu/Setup/Inputs/pH Glass/Diag. settings/Glass impedance (SCS)/Lower warning limit
124	Menu/Setup/Inputs/pH Glass/Diag. settings/Glass impedance (SCS)/Upper alarm limit
125	Menu/Setup/Inputs/pH Glass/Diag. settings/Glass impedance (SCS)/Upper warning limit
126	Menu/Setup/Inputs/pH Glass/Diag. settings/Sensor Condition Check
127	Menu/Setup/Inputs/pH Glass/Diag. settings/Sensor Condition Check
145	Menu/Setup/Inputs/Diag. settings/Delta slope/Alarm limit
157	Menu/Setup/Inputs/Nitrate/Diag. settings/Limits operating hours/Filter change

No.	Path to software function
168	Menu/Setup/Inputs/Cond c/Polarisation
169	Menu/Setup/Inputs/Oxygen (amp.)/Diag. settings/Cap calibrations/Alarm limit
178	Menu/Setup/Inputs/Oxygen (amp.)/Diag. settings/Cap sterilisations/Alarm limit
179	Menu/Setup/Inputs/Diag. settings/Limits operating hours/Operation > 300 mV
180	Menu/Setup/Inputs/Diag. settings/Limits operating hours/Operation < -300 mV
181	Menu/Setup/Inputs/Oxygen (opt.)/Diag. settings/Limits operating hours/Operation < 25µs
182	Menu/Setup/Inputs/Oxygen (opt.)/Diag. settings/Limits operating hours/Operation > 40 µs
183	Menu/Setup/Inputs/Oxygen (amp.)/Diag. settings/Limits operating hours/Operation > 15 nA
184	Operating time
185	Menu/Setup/Inputs/Oxygen (amp.)/Diag. settings/Limits operating hours/Operation > 50 nA
186	Operating time
187	Menu/Setup/Inputs/Cond c/Diag. settings/Limits operating hours/Operation > 80°C < 100nS/cm
188	Menu/Setup/Inputs/Diag. settings/Limits operating hours/Operation < 5°C
190	Menu/Setup/Inputs/Diag. settings/Limits operating hours/Operation > 25°C
192	Menu/Setup/Inputs/Diag. settings/Limits operating hours/Operation > 40°C
193	Menu/Setup/Inputs/Diag. settings/Limits operating hours/Operation > 80°C
194	Menu/Setup/Inputs/Diag. settings/Limits operating hours/Operation > 100°C
195	Menu/Setup/Inputs/Diag. settings/Limits operating hours/Operation > 120°C
196	Menu/Setup/Inputs/Diag. settings/Limits operating hours/Operation > 125°C
197	Menu/Setup/Inputs/Diag. settings/Limits operating hours/Operation > 140°C
198	Menu/Setup/Inputs/Diag. settings/Limits operating hours/Operation > 150°C
199	Menu/Setup/Inputs/Diag. settings/Limits operating hours/Operating time
504	Menu/Setup/Inputs/Diag. settings/Zero point/Upper alarm limit
505	Menu/Setup/Inputs/Diag. settings/Zero point/Upper warning limit
506	Menu/Setup/Inputs/Diag. settings/Zero point/Lower alarm limit
507	Menu/Setup/Inputs/Diag. settings/Zero point/Lower warning limit
508	Menu/Setup/Inputs/Oxygen (amp.)/Diag. settings/Slope/Lower alarm limit
509	Menu/Setup/Inputs/Oxygen (amp.)/Diag. settings/Slope/Lower warning limit
510	Menu/Setup/Inputs/Oxygen (amp.)/Diag. settings/Slope/Upper alarm limit
511	Menu/Setup/Inputs/Oxygen (amp.)/Diag. settings/Slope/Upper warning limit
512	Menu/Setup/Inputs/Oxygen (amp.)/Diag. settings/Zero point/Alarm limit
513	Menu/Setup/Inputs/Oxygen (amp.)/Diag. settings/Zero point/Warning limit

No.	Path to software function
514	Menu/Setup/Inputs/pH ISFET/Diag. settings/Operating point/Upper alarm limit
515	Menu/Setup/Inputs/pH ISFET/Diag. settings/Operating point/Upper warning limit
516	Menu/Setup/Inputs/pH ISFET/Diag. settings/Operating point/Lower alarm limit
517	Menu/Setup/Inputs/pH ISFET/Diag. settings/Operating point/Lower warning limit
518	Menu/Setup/Inputs/Diag. settings/Delta slope/Warning limit
519	Menu/Setup/Inputs/Diag. settings/Delta zeropoint/Alarm limit
520	Menu/Setup/Inputs/Diag. settings/Delta zeropoint/Warning limit
521	Menu/Setup/Inputs/pH ISFET/Diag. settings/Delta operating point/Alarm limit
522	Menu/Setup/Inputs/pH ISFET/Diag. settings/Delta operating point/Warning limit
529	Menu/Setup/Inputs/Oxygen (amp.)/Diag. settings/Cap calibrations/Warning limit
842	Menu/Setup/Inputs/ORP/Diag. settings/ORP-Meas value/Upper alarm limit
843	Menu/Setup/Inputs/ORP/Diag. settings/ORP-Meas value/Lower alarm limit
904	Menu/Setup/Inputs/Diag. settings/Process Check System
934	Menu/Setup/Inputs/Diag. settings/Limits operating hours
935	Menu/Setup/Inputs/Diag. settings/Limits operating hours
942	Menu/Setup/Inputs/ORP/Diag. settings/ORP-Meas value/Upper warning limit
943	Menu/Setup/Inputs/ORP/Diag. settings/ORP-Meas value/Lower warning limit

3.3 Device-specific errors

Problem	Possible cause	Tests and/or remedial measures
The device cannot be switched on/ display remains dark	No supply voltage	Check if voltage supplied
	Basic module defective	Replace basic module
Values appear on display but: – Display does not change and / or – Device cannot be operated	Module not wired correctly	Check modules and wiring
	Impermissible operating system condition	Switch off device and switch it on again
Control signals are not accepted or outputs do not switch	Incorrect program setting	Check program setting
	Incorrect wiring	Check wiring
	Electronics failure	Replace basic module

Problem	Possible cause	Tests and/or remedial measures
Sample not representative	Siphon in sampling hose	Check sampling hose
	Connection not air-tight/sampling hose taking in air	<ul style="list-style-type: none"> - Check tubes/connections - Check the sampling hose is routed correctly
	Bottles not being filled correctly	<ul style="list-style-type: none"> - Incorrect distribution selected in the controls - Calibrate the distribution arm
	Distribution arm does not move	<ul style="list-style-type: none"> - Incorrect distribution selected in the controls - Check distribution arm connection - Distributor defective, replace distributor or - Have repaired by E+H Service
	Incorrect bottle filled	<ul style="list-style-type: none"> - Incorrect distribution selected in the controls
	Wrong pump tube	Only use genuine pump tube
	Faulty sensory mechanism	Replace sensory mechanism (contact E+H Service)
No sampling	Connection leaking	Check tubes/connections for leaks
	Sampling hose taking in air	Check the sampling hose is routed correctly
	Wrong pump tube	Only use genuine pump tube
	Faulty sensory mechanism	Replace sensory mechanism (contact E+H Service)
Implausible measured values (only for version with sensors with the Memosens protocol)	Inputs defective	First perform tests and take measures as outlined in "Process-specific errors" section Measuring input test: <ul style="list-style-type: none"> - Connect a resistor instead of the conductivity sensor
Current output, incorrect current value	Incorrect adjustment	Check with integrated current simulation, connect mA meter directly to current output.
	Load too large	
	Shunt / short to ground in current loop	
No current output signal	Basic module defective	Check with integrated current simulation, connect mA meter directly to current output.

3.4 Process errors without messages

3.4.1 pH/ORP measurement

Problem	Possible cause	Tests and/or remedial measures
Display values deviate from reference measurement	Incorrect calibration	Repeat the calibration. Where necessary, check and repeat the calibration with the reference device.
	Sensor fouled	Clean the sensor.
	Temperature measurement	Check the temperature measured values of both devices.
	Temperature compensation	Check the settings for temperature compensation and adjustment for both devices.
Measuring chain zero-point cannot be adjusted	Contaminated reference system	Test with new sensor
	Junction clogged	Clean or grind junction
	Asymmetric sensor voltage too high	Clean junction or test with another sensor
No change or subtle change in display	<ul style="list-style-type: none"> – Sensor fouled – Sensor old – Sensor defective (reference lead) 	Clean the sensor.
	Reference has low level of KCl	Check KCl supply: 0.8 bar (12 psi) over medium pressure
Measuring chain slope: <ul style="list-style-type: none"> – Cannot be adjusted – To low – No slope 	Device input defective	Check device directly.
	<ul style="list-style-type: none"> – Sensor old – Hair-line crack in the glass membrane 	Renew sensor.
Constant, incorrect measured value	Sensor does not immerse properly or protection cap not removed	Check installation position, remove protection cap.
	Air pockets in assembly	Check assembly and orientation.
	Ground fault at or in device	Perform test measurement in isolated vessel, with buffer solution if applicable.
	Hair-line crack in the glass membrane	Renew sensor.
	Device in impermissible operating condition (does not respond when key pressed)	Switch off device and switch it on again.
Incorrect temperature value	Sensor failure	Replace sensor
Fluctuations in measured value	Interference on signal output cable	Check cable routing, route cable separately if necessary.
	Interference potential in medium	Eliminate source of interference or ground medium as close as possible to sensor.

Problem	Possible cause	Tests and/or remedial measures
No current output signal	Cable disconnected or short-circuited	Disconnect cable and measure directly at device.
	Output defective	See "Device-specific errors" section.
Fixed current output signal	Current simulation active	Switch off simulation.
Incorrect current output signal	Total load in current loop too high	Measure voltage directly at device and compare to supply and signal voltage (→ Technical data, Part 1).
	EMC (interference coupling)	Check wiring. Identify and eliminate cause of interference.

3.4.2 Conductivity measurement

Problem	Possible cause	Tests and/or remedial measures
Display values deviate from reference measurement	Incorrect calibration	Repeat the calibration. Where necessary, check and repeat the calibration with the reference device.
	Sensor fouled	Clean the sensor.
	Temperature measurement	Check the temperature measured values of both devices.
	Temperature compensation	Check the settings for temperature compensation and adjustment for both devices.
Display values deviate from reference measurement	Polarization fields	Use suitable sensor: <ul style="list-style-type: none"> ■ Larger cell constant ■ Graphite instead of stainless steel (observe material resistance properties)
Implausible measured values: – Measured value constantly 000 – Measured value too low – Measured value too high – Measured value frozen – Current output value not as expected	Short-circuit/moisture in sensor	Check sensor.
	Short-circuit in cable or socket	Check cable and socket.
	Disconnection in sensor	Check sensor.
	Disconnection in cable or socket	Check cable and socket.
	Incorrect cell constant setting	Check cell constant.
	Incorrect output assignment	Check assignment of measured value to current signal.
	Air pockets in assembly	Check assembly and orientation.
	Ground fault at or in device	Measure in isolated vessel.
Device in impermissible operating condition (does not respond when key pressed)	Switch off device and switch it on again.	

Problem	Possible cause	Tests and/or remedial measures
Incorrect temperature value	Incorrect temperature sensor wiring	Check connections on basis of wiring diagram; three-wire connection always required.
	Measuring cable defective	Check cable for disconnection, short-circuit, shunt.
	Incorrect sensor type configured	Set correct temperature sensor type.
Measured value in process incorrect	No/incorrect temperature compensation	ATC: select type of compensation; if linear, set suitable coefficients. MTC: set process temperature.
	Incorrect temperature measurement	Check temperature measured value.
	Bubbles in medium	Suppress formation of bubbles by: <ul style="list-style-type: none"> – Gas bubble trap – Creating counterpressure (orifice plate) – Measurement in bypass
	Flow rate too high (can lead to bubble formation)	Reduce flow rate or select less turbulent mounting location.
	Voltage potential in medium (only for conductive)	Ground medium close to sensor.
	Sensor fouling or buildup on sensor	Clean sensor (see "Cleaning the conductivity sensors" section).
Fluctuations in measured value	Interference on signal output cable	Check cable routing, route cable separately if necessary.
	Interference potential in medium	Eliminate source of interference or ground medium as close as possible to sensor.
	Interference on measuring cable	Connect cable shield as per wiring diagram.
No current output signal	Cable disconnected or short-circuited	Disconnect cable and measure directly at device.
	Output defective	See "Device-specific errors" section.
Fixed current output signal	Current simulation active	Switch off simulation.
Incorrect current output signal	Total load in current loop too high	Measure voltage directly at device and compare to supply and signal voltage (→ Technical data, Part 1).
	EMC (interference coupling)	Check wiring. Identify and eliminate cause of interference.

3.4.3 Oxygen measurement

Problem	Possible cause	Tests and/or remedial measures
Display value - - - -	Sensor failure	Test with new sensor
	Sensor cable disconnected	Check cable or cable extension.
	Incorrect sensor connection	Check the connection at input module (→ BA, Part 1 "Wiring").
	Electronics module defective	Replace the module.
No change or subtle change in display	<ul style="list-style-type: none"> - Sensor fouled - Sensor old (membrane) 	<ul style="list-style-type: none"> ■ Clean the sensor. ■ If necessary: <ul style="list-style-type: none"> - Change electrolyte, change membrane cap (amperometric sensor) - Change fluorescence cap (optical sensor)
Constant, incorrect measured value	Device in impermissible operating condition (does not respond when key pressed)	Switch off device and switch it on again.
Measured value too low	Membrane fouled	Clean or replace cap
	Electrolyte exhausted or contaminated	Change electrolyte
	Anode coating worn	Repolarize sensor
	Black anode coating	Regenerate sensor in factory
Measured value too high	Air pocket under membrane	Clean sensor, optimize installation where necessary
	Polarization not complete	Wait until polarization time elapses (→ Technical data in sensor operating manual)
Implausible measured value	Incorrect temperature measurement	Check/correct value.
	Incorrect altitude setting	Incorrect calibration
	Incorrect air pressure	Reset and repeat calibration.
Incorrect temperature value	Incorrect sensor connection	Check the connection at input module (→ BA, Part 1 "Wiring").
	Temperature sensor defective	Replace sensor
Fluctuations in measured value	Interference on signal output cable	Check cable routing, route cable separately if necessary.
	Interference potential in medium	Eliminate source of interference or ground medium as close as possible to sensor.
No current output signal	Cable disconnected or short-circuited	Disconnect cable and measure directly at device.
	Output defective	See "Device-specific errors" section.
Fixed current output signal	Current simulation active	Switch off simulation.

Problem	Possible cause	Tests and/or remedial measures
Incorrect current output signal	Total load in current loop too high	Disconnect output and measure directly at device.
	EMC (interference coupling)	Disconnect both output cables and measure directly at device.

3.4.4 Turbidity and nitrate measurement

Problem	Possible cause	Tests and/or remedial measures
Display value - - - -	Sensor failure	Test with new sensor
	Sensor cable disconnected	Check cable or cable extension.
	Incorrect sensor connection	Check the connection at input module (→ BA, Part 1 "Wiring").
	Electronics module defective	Replace the module.
No change or subtle change in display	Sensor fouled	Clean the sensor.
Constant, incorrect measured value	Device in impermissible operating condition (does not respond when key pressed)	Switch off device and switch it on again.
Implausible measured value	Sensor not calibrated or incorrectly calibrated	Calibration with original sample might be necessary for concentration or solids content.
	Sensor fouled	Clean sensor
	Sensor installed in "dead zone" or air pocket in assembly or flange	Check installation position, move sensor to area that receives good flow. Pay attention when mounting in horizontal pipes
	Incorrect sensor orientation	Align sensor: <ul style="list-style-type: none"> ■ Normal media: Direct flow to measuring window ■ For high solids content: Align measuring window at angle of 90° to flow
Incorrect temperature value	Incorrect sensor connection	Check the connection at input module (→ BA, Part 1 "Wiring").
	Temperature sensor defective	Replace sensor
Fluctuations in measured value	Interference on signal output cable	Check cable routing, route cable separately if necessary.
	Irregular flow / turbulence / air bubbles / large solid particles	Select a better mounting location or reduce turbulence, use a large measured value damping factor if necessary Set gas bubble threshold to 100 %

Problem	Possible cause	Tests and/or remedial measures
No current output signal	Cable disconnected or short-circuited	Disconnect cable and measure directly at device.
	Output defective	See "Device-specific errors" section.
Fixed current output signal	Current simulation active	Switch off simulation.
Incorrect current output signal	Total load in current loop too high	Disconnect output and measure directly at device.
	EMC (interference coupling)	Disconnect both output cables and measure directly at device.
Value switches to zero and back to measured value	Air bubbles	Do not mount sensor above aeration discs

3.5 Return

The sampler is repaired on site.
 Contact your Endress+Hauser Service Department.

3.6 Disposal

The device contains electronic components and must therefore be disposed of in accordance with regulations on the disposal of electronic waste.
 Please comply with local regulations and guidelines.

 You can return the 12V storage batteries for disposal.

3.7 Software history

Date	Version	Changes to software	Documentation: edition
06/2010	01.00	Original software	BA465C/07/EN/06.10 BA470C/07/EN/06.10 BA464C/07/EN/04.10 BA467C/07/EN/04.10

4 Accessories

 The most important accessories available at the time this document went to print are listed below.

Contact your Service Department or sales center for accessories that are not listed here.

4.1 Accessories for Liquiport 2010 CSP44

Order No.	Base, complemented
71111864	CSP44 base + 1 x 20 liter (5.28 US gal.), PE
71111865	CSP44 base + 1 x 5 liter (1.32 US gal.), glass
71111866	CSP44 base + 12 x 2 liter (0.53 US gal.), PE
71111867	CSP44 base + 12 x 0.7 liter (0.18 US gal.), glass
71111868	CSP44 base + 24 x 1 liter (0.26 US gal.), PE
71111870	CSP44 base + 12 x 1 liter (0.26 US gal.) + 6 x 2 liter (0.53 US gal.), PE
Bottles + caps	
71112221	20 liter (5.28 US gal.) PE + cap, 1 pc.
71111168	5 liter (1.32 US gal.) glass + cap, 1 pc.
71111178	2 liter (0.53 US gal.) PE wedge shaped bottle + cap, 12 pcs.
71111176	1 liter (0.26 US gal.) PE wedge shaped bottle + cap, 24 pcs.
71111874	0.7 liter (0.18 US gal.) glass + cap, 12 pcs.
Accessories base	
71111878	Kit CSP44 base cover, transporting
71111880	Kit CSP44 freezer cartridge
Suction line	
71111233	Suction line ID 10 mm (3/8"), reinforced fabric, PVC, clear, length 10 m (33 ft), suction head V4A
71111234	Suction line ID 10 mm (3/8"), EPDM, length 10 m (33 ft), suction head V4A
71111482	... m; suction line coil ID 10 mm (3/8"), PVC
71111484	... m; suction line coil ID 10 mm (3/8"), EPDM
71111184	Strainer V4A 316(x) for ID 10 mm (3/8"), 1 pc.
Tubing customized	
71114701	Pump tubing, 2 pc.
71114702	Pump tubing, 25 pcs.
Installation	
71111881	CSP44 suspension kit, for use in 500 to 600 mm diameter manhole
Power supply	
71111872	Dosing hose to distributor, 2 pcs.
71111882	Dosing hose to distributor, 25 pcs.
71111883	Kit CSP44 power pack/charger for indoor use, 90 to 265 V AC
71111884	Kit CSP44 power pack/charger for outdoor use, IP 65, 90 to 265 V AC
Communication; software	
51516983	Commubox FXA291 + FieldCare Device Setup
Retrofit kits	
71111879	Kit CSP44 retrofit distribution system (distribution arm, distribution drive)

4.2 Measuring cable

Memosens data cable CYK10

- For digital sensors with Memosens technology:
 - pH, ORP, oxygen (amperometric), chlorine, conductivity (conductive)
- Order as per product structure, see Technical Information (TI376C/07/en)

4.3 Sensors

4.3.1 Glass electrodes

Orbisint CPS11D

- pH sensor with Memosens technology
- Dirt-repellent PTFE junction
- Order depending on version, see Technical Information (TI028C/07/en)

Ceraliquid CPS41D

- pH sensor with Memosens technology
- Ceramic junction and KCl liquid electrolyte
- Order depending on version, see Technical Information (TI079C/07/en)

Ceragel CPS71D

- pH sensor with Memosens technology
- Twin-chamber reference system and integrated bridge electrolyte
- Order depending on version, see Technical Information (TI245C/07/en)

Orbipore CPS91D

- pH sensor with Memosens technology
- Open aperture junction for media with high potential for fouling
- Order depending on version, see Technical Information (TI375C/07/en)

Orbisint CPS12D

- ORP sensor with Memosens technology
- Dirt-repellent PTFE junction;
- Order depending on version, see Technical Information (TI367C/07/en)

Ceraliquid CPS42D

- ORP sensor with Memosens technology
- Ceramic junction and KCl liquid electrolyte
- Order depending on version, see Technical Information (TI373C/07/en)

Ceragel CPS72D

- ORP sensor with Memosens technology
- Twin-chamber reference system and integrated bridge electrolyte
- Order depending on version, see Technical Information (TI374C/07/en)

4.3.2 pH-ISFET sensors

Tophit CPS471D

- Sterilizable and autoclavable ISFET sensor with Memosens technology
- For food and pharmaceutical industry, process engineering, water treatment and biotechnology
- Order depending on version, see Technical Information (TI283C/07/en)

Tophit CPS441D

- Sterilizable ISFET sensor with Memosens technology
- For low-conductivity media, with liquid KCl electrolyte

- Order depending on version, see Technical Information (TI352C/07/en)

Tophit CPS491D

- ISFET sensor with Memosens technology
- Open aperture junction for media with high potential for fouling
- Order depending on version, see Technical Information (TI377C/07/en)

4.3.3 Inductive conductivity sensors

 You can only connect sensors with M12 plug.

Indumax CLS50D

- Inductive conductivity sensor with very good resistance properties for standard, Ex and high-temperature applications
- Memosens protocol
- Order as per product structure, see Technical Information TI182C/07/en

4.3.4 Oxygen sensors

 You can only connect sensors with M12 plug.

Oxymax COS51D

- Amperometric sensor for dissolved oxygen, with Memosens technology
- Order as per product structure, see Technical Information (TI413C/07/en)

Oxymax COS61D

- Optical oxygen sensor for drinking water and industrial water measurement
- Measuring principle: quenching
- Memosens protocol
- Material: stainless steel 1.4571 (AISI 316Ti)
- Order as per product structure, see Technical Information (TI387C/07/en)

4.3.5 Turbidity sensors

 You can only connect sensors with M12 plug.

Turbimax CUS51D

- For nephelometric turbidity and solids measurement in wastewater
- 4-beam alternating light method based on scattered light
- With Memosens protocol
- Order as per product structure (Technical Information TI461C/07/EN)

4.3.6 Nitrate sensors

 You can only connect sensors with M12 plug.

Viomax CAS51D

- Nitrate measurement in drinking water and wastewater
- With Memosens protocol
- Order as per product structure (Technical Information TI459C/07/EN)

5 Spare parts

i Contact your Endress+Hauser Service if you have any further questions regarding spare parts.

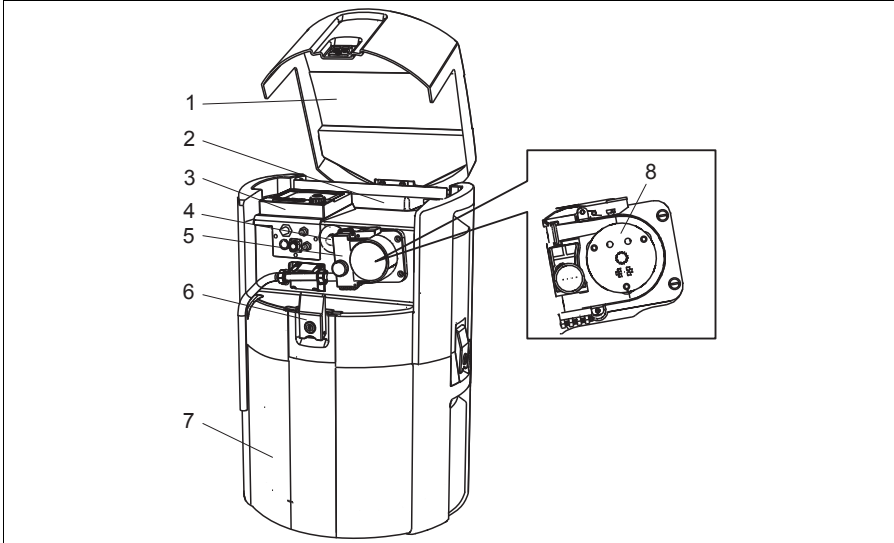
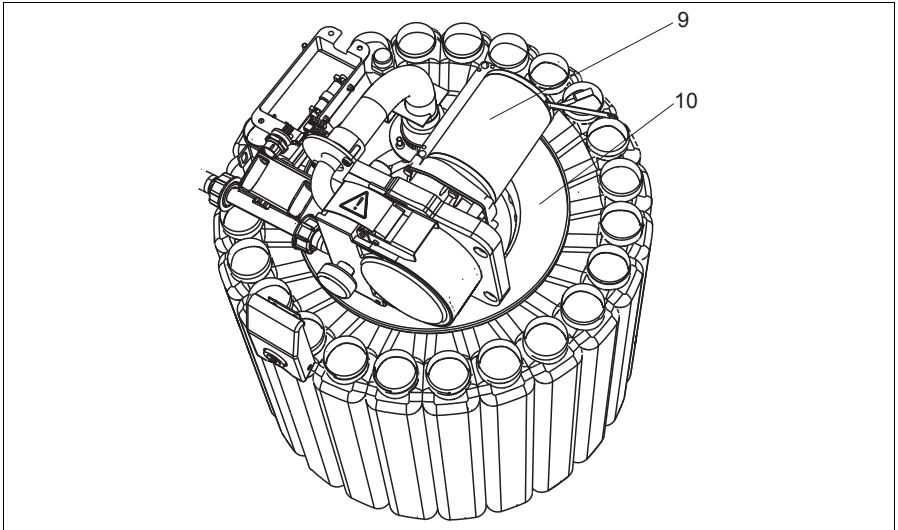

Fig. 6: Spare parts

a0014211

Item No.	Designation and contents	Order number Spare parts kit
1	Lid for housing upper complete	71119023
2	Rechargeable battery pack	71119018
3	Housing cover with display CM44	71119035
4	Pump hose, 2 pieces	71119014
	Pump hose, 25 pieces	71119016
5	Peristaltic pump: pump housing	71119029
6	Lockable latch with keys	71119017
	Keys	71119017
7	Housing base	71119022
8	Peristaltic pump: pump head	71119008



a0014212

Fig. 7: Spare parts

Item No.	Designation and contents	Order number Spare parts kit
9	Peristaltic pump: pump motor	71119030
10	Downholder complete	71119013
	Distribution arm	71119007
	Distribution arm	71119025
	Seal set for peristaltic pump: O-ring ID=12.42 W=1.78 AD=15.98 EPDM, 2 pcs O-ring ID=20.92 W=2.62 AD=25.53 EPDM, 2 pcs O-ring ID=13.00 W=4.00 AD=21.00 NBR, 1 pc	71110928

Index

A

Accessories	
Measuring cable	45
Sensors	46

C

Calibration	9
Cleaning	
Assemblies	9
Housing	6
Sample compartment	8
Sensors	9
Wetted parts	7
Cleaning assemblies	9
Cleaning sensors	9
Cleaning the housing	6
Cleaning the sample compartment	8

D

Device behavior	20
Device test	15
Device-specific errors	37
Diagnostics	
Adjusting device behavior	20
Device test/Reset	15
Device-specific diagnostics messages	21
Diagnostic list	11
Error messages	19
Logbooks	11
Manual hold	17
Measured values	15
Message classification	19
Sensor information	18
Sensor replacement	17
Sensor-specific diagnostics messages	25
Simulation	18
System information	14
Term information	17
Troubleshooting settings	35

E

Error categories	19
Error messages	19

L

Logbooks	11
--------------------	----

M

Maintenance	4
Manual hold	17
Measured values	15
Measuring cable	45

P

Process error	
pH/ORP	39
turbidity and nitrate	43
Process errors	
Conductivity	40
Oxygen	42

R

Recommended maintenance	4
Replacement	
Pump tube	5
Storage battery	10
Replacing the pump tube	5
Replacing the storage batteries	10
Reset	15
Return	44
Run times	17

S

Sensor information	18
Sensor replacement	17
Sensors	46
Simulation	18
Spare parts	48
System information	14

T

Term information	17
Troubleshooting	19

www.endress.com/worldwide

Endress+Hauser 
People for Process Automation

BA470C/07/EN/06.10
FM+SGML 6.0

