

Operating Instructions

FLAWSIC300

Ultrasonic Gas Flow Meter

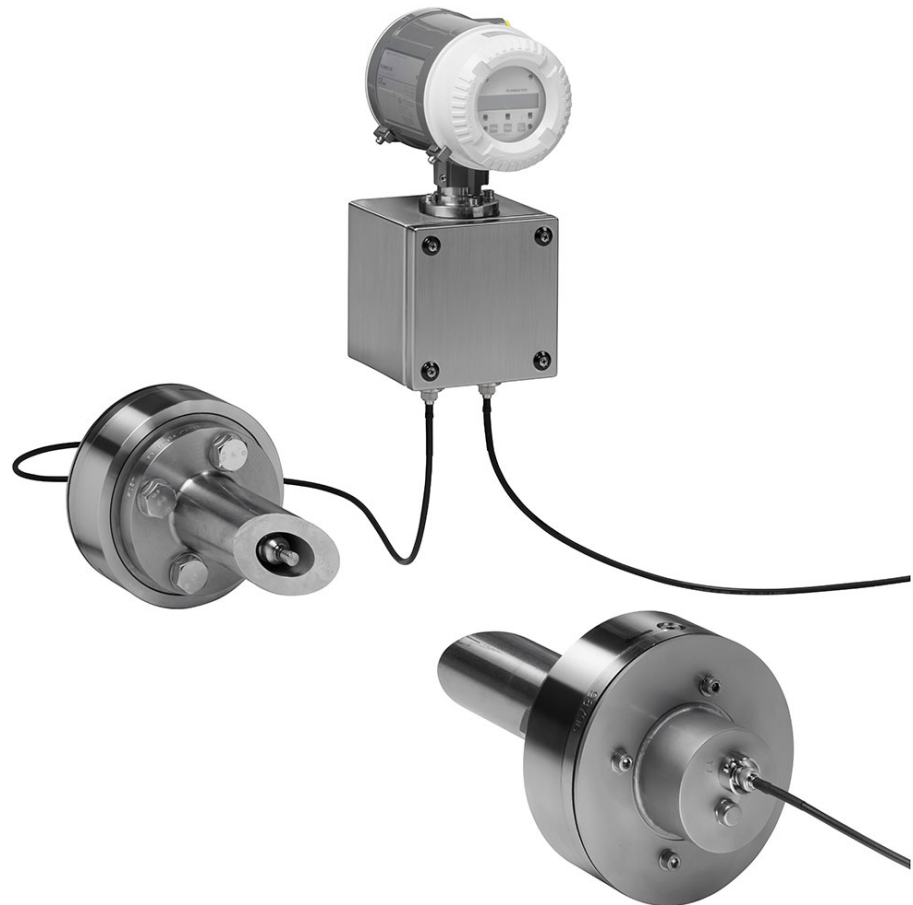

Described product

Product name: FLOWSIC300
 Firmware: Version 3.5.10 or higher

Manufacturer

Endress+Hauser SICK GmbH+Co. KG
 Bergener Ring 27
 01458 Ottendorf-Okrilla
 Germany

Legal information

This work is protected by copyright. Any rights derived from the copyright shall be reserved for Endress+Hauser SICK GmbH+Co. KG. Reproduction of this document or parts of this document is only permissible within the limits of the legal determination of Copyright Law.
 Any modification, abridgment or translation of this document is prohibited without the express written permission of Endress+Hauser SICK GmbH+Co. KG.
 The trademarks stated in this document are the property of their respective owner.

© Endress+Hauser SICK GmbH+Co. KG. All rights reserved.

Original document







This document is an original document of Endress+Hauser SICK GmbH+Co. KG.



Glossary

ASCII	American S tandard C ode for Information Interchange
ANSI	American National Standards Institute
AWG	American Wire Gage
CBM	Condition Based Maintenance
CSA	Canadian Standards Association
DC	Direct Current
DIN	Deutsches Institut für Normung (German Standards Institute)
DN	Standard inner diameter
DSP	Digital Signal Processor
EC	European C ommunity
EN	Euro Norm
EVC	Electronic Volume Corrector
Ex	P otentially e xplosive
HART	Highway Addressable Remote Transducer (standardized communication system for field bus systems) → ... http://www.hartcomm.org
act.	in O perating state
std.	in S tandard state
IEC	International Electrotechnical Commission
LCD	Liquid Crystal Display
LED	Light Emitting Diode
MEPAFLOW	Menu driven configuration and diagnosis for FLOWSIC
MDR	Manufacturer Data Record
NAMUR	Normenarbeitsgemeinschaft für Mess- und Regeltechnik in der chemischen Industrie (now "Interessengemeinschaft Prozessleittechnik der chemischen und pharmazeutischen Industrie")
PC	Personal Computer (Desktop-PC, Laptop, Notebook, Netbook usw.)
PTB	Physikalisch Technische Bundesanstalt
RTU	Remote Terminal Unit
SPU	Signal Processing Unit
VDE	Verband der Elektrotechnik Elektronik Informationstechnik





Warning symbols

	IMMEDIATE DANGER of serious injuries or death
	Hazard (general)
	Hazard in potentially explosive atmospheres
	Hazard through explosive substances/substance mixtures
	Hazards through electrical voltage
	Hazards through toxic substances

Warning levels / signal words

DANGER	Risk or hazardous situation which <i>will</i> result in severe personal injury or death.
WARNING	Risk or hazardous situation which <i>could</i> result in severe personal injury or death.
CAUTION	Hazard or unsafe practice which <i>could</i> result in personal injury or property damage.
NOTICE	Hazard which <i>could</i> result in property damage.

Information symbols

	Important technical information for this product
	Information on product condition with regard to explosion protection (general)
	Tip
	Supplementary information
	Note referring to information at another location

1	Important information	9
1.1	About this document	10
1.2	For your safety	10
1.2.1	Hazards during installation	10
1.2.2	Hazards during operation	11
1.3	Intended use	11
1.3.1	Purpose of the device	11
1.3.2	Installation site	11
1.3.3	Operation in pressure applications	12
1.3.4	Operation in potentially explosive atmospheres	13
1.4	Restrictions of use	14
1.4.1	Customized versions	14
1.4.2	Functional restrictions through contamination	14
1.4.3	Voltage limitations for intrinsic safety	15
1.5	Additional information	15
1.6	Responsibility of user	16
1.7	Disposal information	17
2	Product description	19
2.1	Basic system information	20
2.1.1	Functional principle	20
2.1.2	Measured variables	21
2.1.3	Calculating and calibrating the volume flow rate	22
2.2	System configurations	23
2.3	System overview	24
2.3.1	System components	24
2.3.2	Sender/receiver units	25
2.3.3	SPU	26
2.3.4	Integration in the plant	27
2.4	Scope of delivery	28
2.5	Installation accessories	29
2.5.1	Spool piece	29
2.5.2	Fitting tool	30
2.6	Output configurations	33
2.6.1	Hardware variants and signal outputs (I/O configuration)	33
2.6.2	Behavior of the analog output (absolute value creation/linear)	35
2.7	Wiring of digital outputs	36
2.7.1	Hardware variant C(6/10) with integrated electronic volume corrector (EVC)	37
2.8	Operating modes and signal output	38
2.8.1	Operation mode and Configuration mode	38
2.8.2	Device status	39
2.8.3	Signaling pulse output and state	40
2.9	Self-diagnosis with user warnings	41
2.10	Data handling in the FLOWSIC300	42
2.10.1	Integrated volume counters	42
2.10.2	Logbooks	43
2.10.3	DataLogs	44
2.10.4	Diagnostics Comparison Log	45

2.11	MEPAFLOW600 CBM	46
2.11.1	Software installation	46
2.11.2	Overview	47
3	Preparing for installation	49
3.1	Overview of installation work	50
3.2	Project planning	51
3.2.1	Project planning checklist	51
3.2.2	Determining the measuring and installation location	52
3.2.3	Further notes for project planning	55
3.3	Preparation work	56
3.3.1	Checking delivery	56
3.3.2	Checking operating conditions	56
3.3.3	Tools required	56
3.4	General safety information	57
3.5	Safety information on gas tightness	57
4	Installing the nozzles	59
4.1	Assembly information	60
4.1.1	Safety information for assembly work	60
4.1.2	Position of nozzles on the pipeline	61
4.2	Nozzle assembly	62
4.2.1	Assembly information	62
4.2.2	Marking the nozzle positions	63
4.2.3	Welding the nozzle on	66
4.2.4	Determining the path length and installation angle	69
4.3	Installing the spool piece (optional)	72
4.3.1	Safety information for the spool piece	72
4.3.2	Inserting the spool piece in the pipeline	73
4.3.3	Determining the pipeline diameter	73
5	Fitting the sender/receiver units in idle operation (cold tap)	75
5.1	Important Information	76
5.2	Fitting the sender/receiver units in idle operation /with non-pressurized line	76
5.2.1	Drilling a hole in the pipeline	76
5.2.2	Fitting the sender/receiver unit	77
5.2.3	Installing the ultrasonic sensor	79
5.3	Leak tightness check after installation	81

6	Fitting the sender/receiver units in running operation (hot tap)	83
6.1	Safety information for the fitting tool	84
6.1.1	Work safety	84
6.1.2	Safety of hydraulic equipment	84
6.1.3	Proper installation	84
6.1.4	Accident risk	84
6.2	Using the fitting tool	85
6.2.1	Assembling the fitting tool	85
6.2.2	Moving the hydraulic	85
6.2.3	Setting the coupling	86
6.2.4	Using the ball valve	88
6.2.5	Checking the function of the pressure gauge on the ball valve	89
6.3	Installing the sender/receiver unit and ball valve	90
6.4	Drilling the holes in the pipeline	94
6.5	Fitting an ultrasonic sensor with fitting tool	95
7	Installing the electronics unit	105
7.1	Fitting the electronics unit	106
7.1.1	Fitting information	106
7.1.2	Installation location requirements	106
7.1.3	Fastening the electronics unit	107
7.1.4	Turning the SPU	108
7.1.5	Connecting the connection cable	108
7.2	Electrical installation	109
7.2.1	General information	109
7.2.2	Cable specifications	110
7.2.3	Checking the cable loops	111
7.2.4	SPU terminal compartment	112
7.2.5	Terminal assignment	114
7.2.6	Requirements for use in hazardous areas with potentially explosive atmospheres	115

8	Initial start-up	123
8.1	Information on initial start-up	124
8.2	Connecting to a PC	126
8.2.1	Connecting to a serial interface (RS232/COM)	126
8.2.2	Connecting to a USB port	127
8.3	Connecting to MEPAFLOW600 CBM	128
8.3.1	Starting MEPAFLOW600 CBM	128
8.3.2	Choosing a user access level	129
8.3.3	Creating a new device entry in the Device database	129
8.3.4	Online connection: Connect	130
8.3.5	Online Connection: Ethernet	131
8.4	Identification	133
8.5	Start-up	134
8.5.1	Entering the installation parameters	134
8.5.2	Field setup wizard	136
8.5.3	Location information and unit system (Field setup page 1 of 8)	137
8.5.4	Application data (Field setup wizard, page 2 of 8)	138
8.5.5	Integrated electronic volume corrector (EVC) (Field setup wizard, page 3 of 8)	138
8.5.6	I/O configuration – output configurations (Field setup wizard, page 4 of 8)	139
8.5.7	I/O configuration – terminal assignment (Field setup wizard, page 5 of 8)	140
8.5.8	LCD Display settings (Field setup wizard, page 6 of 8)	143
8.5.9	Configuration update (Field setup wizard, page 7 of 8)	145
8.5.10	Maintenance report (Field setup wizard, page 8 of 8)	146
8.5.11	Separating the connection to the device and terminating the session	147
8.6	Functional check	148
8.6.1	Checking the operating state on a version with LCD front panel	148
8.6.2	Function test with MEPAFLOW600 CBM	149
9	Maintenance	151
9.1	Protective measures when working on the pipeline	152
9.2	Components with gas contact in the pipeline	152
9.3	Maintenance work overview	152
9.4	Checking gas tightness	153
9.5	Functional check	154
9.5.1	Comparing theoretical and measured sound velocity (SOS)	154
9.5.2	Checking the device state	155
9.5.3	Time synchronization	156
9.6	Maintenance reports	157
9.7	Logbook backup	158
9.7.1	Checking the logbook	158
9.7.2	DataLogs check	160

10	Troubleshooting	163
10.1	General troubleshooting	164
10.2	Displaying status alarms and warnings	164
10.2.1	Checking the device status	165
10.2.2	Checking user warnings	168
10.2.3	Battery service life/capacity	169
10.3	Starting a diagnosis session	170
10.4	Troubleshooting when connecting devices	171
11	Spare parts	173
11.1	Electronics subassembly	174
11.2	Sender/receiver units	175
11.3	Cables	175
11.4	Fitting tool	175
12	Appendix	177
12.1	Conformities	178
12.1.1	CE certificate	178
12.1.2	IECEX	178
12.2	Technical data	179
12.3	Dimensions	180
12.4	Measuring ranges	180
12.5	Logbooks	181
12.5.1	Overview of entries in logbooks and MEPAFLOW600 CBM	181
12.6	SPU terminal assignment	185
12.7	Wiring examples	186
12.7.1	Intrinsically safe installation	186
12.7.2	Non intrinsically safe installation	187
12.8	Type plates	188

FLOWSIC300

1 Important information

- About this document
- For your safety
- Intended use
- Restrictions of use
- Additional information
- Disposal information
- Responsibility of user

1.1 **About this document**

These Operating Instructions contain essential information on the function, installation, start-up and maintenance of the FLOWSIC300.

1.2 **For your safety**

1.2.1 **Hazards during installation**

 **CAUTION: General risks during installation**

- ▶ Observe applicable valid regulations, general standards and guidelines.
- ▶ Observe local safety regulations, operating instructions and special regulations.
- ▶ Observe the information on responsibility of the user (→ p. 16, § 1.6).

 **WARNING: Hazards through the gas in the system**

The following conditions can increase the risk:

- Toxic gas or gas dangerous to health
- Chemically aggressive gas
- Explosive gas
- High gas pressure
- High gas temperature

When ultrasonic sensors are installed on the pipeline when the pipeline is in operation (hot tapping):

- ▶ Only allow skilled persons trained and qualified for this method to carry out the installation. [1]
- ▶ Only start installation work when all planned measures have been checked and expressly approved by the plant operator.

When the hot tapping method is not used to install the device:

- ▶ Only carry out installation work when the system is out of operation and does not contain dangerous gas. [2]

Otherwise escaping gas can possibly be dangerous to health and cause injuries (e.g. poisoning, burns).

[1] The skilled persons must be trained and experienced in hot tapping installations, and know and comply with the legal, generally accepted and in-house regulations and standards.



[2] Also applicable for maintenance and repair work.

 **WARNING: Hazards during installation work**

- ▶ Only allow skilled persons qualified for the planned work to carry out welding, drilling and assembly work
- ▶ Comply exactly with mandatory and approved methods.
- ▶ Observe and comply with regulations of the plant operator.
- ▶ Meticulously check completed work. Ensure leak tightness and strength.

Otherwise hazards are possible and safe operation is not ensured.

1.2.2 **Hazards during operation**

	<p>WARNING: Hazards through leaks</p> <p>Operation in leaky condition is not allowed and possibly dangerous.</p> <ul style="list-style-type: none"> ▶ Check leak tightness of equipment regularly (→ p. 153, §9.4).
	<p>NOTICE: Risk of damage in pipeline</p> <ul style="list-style-type: none"> ▶ Protect the ultrasonic sensors (→ p. 24, Fig. 2) against liquids and mechanical effects. ▶ Pay particular attention here when the pipeline is to be cleaned with a pipeline inspection gauge. ▶ <i>If the pipeline is to be purged with liquid:</i> First observe the information in §9.1 (→ p. 152). <p>Otherwise the ultrasonic sensors can be damaged or made unusable.</p>

1.3 **Intended use**

1.3.1 **Purpose of the device**

The FLOWSIC300 measuring system serves to measure the flow velocity of gases in pipelines. Apart from that, the FLOWSIC300 can also be used to determine the sound velocity and the volumes in operating conditions.

1.3.2 **Installation site**

- The FLOWSIC300 measuring system is electrical equipment designed for use in industrial plants.
- The FLOWSIC300 complies with the basic safety requirements of Annex I of the European Pressure Equipment Directive 2014/68/EU.

1.3.3 **Operation in pressure applications**

FLWSIC300 sender/receiver units as well as the fitting tool are designed for operation in pipelines that retain the pressure. The following Table shows the maximum permissible pressure.

Sender/receiver units

Medium temperature range	Max. design pressure	Operating pressure
-40 °C to 38 °C	103.4 bar	10 ... 100 bar(g)
50 °C	103.4 bar	
100 °C	103 bar	
150 °C	100.3 bar	
180 °C	100 bar	

Fitting tool

Medium temperature range	Max. design pressure	Operating pressure
-30 °C to 38 °C	103.4 bar	<ul style="list-style-type: none"> ● Fitting the sensor: 0 ... 100 bar(g) ● Removing the sensor: 10 ... 100 bar(g)
50 °C	103.4 bar	
100 °C	103 bar	



WARNING: Fitting and removing the ultrasonic sensors in running operation (hot tap)

- Only fit or remove the ultrasonic sensors in running operation with the optional fitting tool.
- Only remove the ultrasonic sensors according to the instructions in the “Service Manual” for the FLOWSIC300.



WARNING: Pressure range for using the fitting tool

- Fitting the ultrasonic sensors is possible in a pressure range from 0 ... 100 bar(g).
- Removing the ultrasonic sensors is possible in a pressure range from 10 ... 100 bar(g).
- Do not remove the ultrasonic sensors when the pressures are lower than 10 bar(g).

1.3.4

Operation in potentially explosive atmospheres



WARNING: Risk of explosions in potentially explosive atmospheres

When the measuring system is to be used in a potentially explosive atmosphere:

- ▶ Only use the FLOWSIC300 measuring system in potentially explosive atmospheres that correspond to the individual device specifications. Otherwise there is a risk of explosions.



The inside of the pipeline does not belong to the surrounding potentially explosive atmosphere. The pipeline does not have to have the same atmospheric conditions as the surrounding Ex zone.



Technical information on operation in potentially explosive atmospheres
→ p. 115, §7.2.6.

1.4 Restrictions of use

1.4.1 Customized versions

All individual operating parameters specified by the customer in the associated questionnaire are considered when manufacturing a FLOWSIC300. This means every FLOWSIC300 is an individual customized measuring system.

Individual features can include:

- Materials
- Sealing design
- Additional equipment (options)
- Measuring ranges
- Basic settings



WARNING: Hazard through incorrect use

- ▶ The FLOWSIC300 may only be used for the specified application case and only within the specified limits.^[1]
- ▶ Observe and comply with the specifications on the type plate.
- ▶ Give priority to individual information delivered with the system (→ p. 15, § 1.5).
Otherwise safe and correct operation is not ensured.

[1] E.g. maximum pressure, maximum temperature, technical characteristic values relating to safety and chemical composition of the gas in the pipeline.



WARNING: Ignition hazard by impacts or friction

The ultrasonic transducers of FLOWSIC300 are made of titanium.

The meter body and parts of the electronic enclosure may be made of aluminum.

In rare cases, ignitable sparks due to impact and friction sparks could occur.

- ▶ The user must ensure that the electronic enclosure, the meter body and the ultrasonic transducers are adequately protected from hazards caused by impact or friction. This is especially true when the ultrasonic transducers of FLOWSIC300 are installed in zone 0 (see § 8.3 EN 60079-0).



WARNING: Ignition hazard by impacts

The maximum piezoelectric energy that can be released through impacts on the ultrasonic transducers exceeds the limit for Gas group IIC specified in §10.7 of EN60079-11:2012.

- ▶ The user must ensure that the ultrasonic transducers are adequately protected from hazards caused by impacts.



WARNING: Ignition hazard through electrostatic discharge

- ▶ The paint film thickness on surfaces accessible from the outside may exceed the permissible thickness for ignition group IIC. The user must take appropriate precautions to avoid ignition hazards due to electrostatic discharge.

1.4.2 Functional restrictions through contamination

- Deposits (dust, particles, condensation) on the ultrasonic sensors of the sender/receiver units reduce measuring precision.
- The measuring function fails when contamination on the ultrasonic sensors is too strong.

1.4.3 **Voltage limitations for intrinsic safety**



WARNING: Hazard for intrinsic safety

- ▶ Ensure voltages in the safe area are not higher than rated voltage $U_M = 253 \text{ V AC}$ (→ p. 115, § 7.2.6).

Otherwise the intrinsic safety of the ultrasonic sensors is not ensured in case of a malfunction.

1.5 **Additional information**

Individual information for each device

Some device components and settings depend on individual operating conditions. The scope of delivery is specified in the individual information delivered with the system. This can include:

- Order and delivery documents
- Configuration specifications made at the factory (basic settings)
- Approval for potentially explosive atmospheres (incl. specifications)
- Specifications for additional equipment and materials

Individual installation dimensions

Individual path parameters (length and angle of the ultrasonic measuring path to the gas flow) resulting from nozzle installation (→ p. 62, § 4.2.1) are required during the initial start-up to complete the configuration.

Additional information for trained skilled persons (when required)

- FLOWSIC300 Service Manual
- FLOWSIC300 Modbus Specification Document
- FLOWSIC300 HARTbus Specification Document



These documents are available from your regional sales organization.

1.6

Responsibility of user

Designated users

These Operating Instructions are intended for skilled persons responsible for the following tasks:

- Installation (setting up/assembly)
- Start-up
- Operating and monitoring during operation
- Maintenance/service
- Skilled persons are persons in accordance with DIN VDE 0105 or IEC 364 or directly comparable standards. It is decisive that these persons can recognize and avoid possible hazards, especially hazards through gases dangerous to health, hot or under pressure.

	<p><i>In potentially explosive atmospheres:</i></p> <ul style="list-style-type: none"> ● Installation, start-up, maintenance and inspection must be carried out by skilled persons with knowledge on ignition protection types and installation procedures, relevant rules and regulations as well as basic principles of range setting. ● The device may only be operated by instructed persons who have been instructed on the tasks to be carried out, possible hazards and protective measures. ● Only skilled persons trained specifically by the manufacturer may carry out repair work. ● Only original spare parts from the manufacturer may be used.
---	---

Safe installation

- ▶ Use the device only as specified in these Operating Instructions. The manufacturer bears no responsibility for any other use.
- ▶ Observe safety information in these Operating Instructions (e.g. → p. 10, § 1.2).
- ▶ Observe applicable valid regulations, standards and guidelines.
- ▶ Observe local safety regulations, operating instructions and regulations.

	The plant operator is responsible for correct and reliable performance of installation work and establishing safe operating conditions.
---	---

Safe operation

- ▶ Carry out the prescribed maintenance work (→ p. 151, §9).
- ▶ Do not remove, add or modify any components to or on the device unless described and specified in the official manufacturer information. Otherwise:
 - The device could become dangerous
 - Any warranty by the manufacturer becomes void
 - The approval for use in potentially explosive atmospheres is no longer valid.

	<p>WARNING: Risk through incorrect use</p> <ul style="list-style-type: none"> ▶ Only operate the FLOWSIC300 in the specified, individual operating conditions (→ p. 14, § 1.4). <p>Otherwise safe operation is not ensured.</p>
---	---

Retention of documents

- ▶ Keep these Operating Instructions available for reference.
- ▶ Pass these Operating Instructions on to a new owner.

1.7

Disposal information**Materials**

- The FLOWSIC300 is mainly made of steel, aluminium and plastic materials.
- It does not contain any toxic, radioactive or other environmentally harmful substances.
- Substances from the pipeline can possibly penetrate, or deposit on seals.

Disposal

- ▶ Dispose of electronic components as electronic waste.
- ▶ Check whether materials that had contact with the pipeline need to be disposed of as special waste.
- ▶ Dispose of the hydraulic fluid of the fitting tool as waste oil.

FLAWSIC300

2 Product description

System components
 Operating modes, device status and signal output
 MEPAFLOW600 CBM

2.1 **Basic system information**

2.1.1 **Functional principle**

The FLOWSIC300 measuring system works according to the principle of ultrasonic transit time difference measurement. Sender/receiver units are mounted on both sides of a pipe-line at a certain angle of inclination to the gas flow (→ Fig. 1).

These sender/receiver units contain piezoelectric ultrasonic sensors that function alternately as senders and receivers. The sound pulses are emitted at angle α to the flow direction of the gas. Depending on angle α and gas flow rate v , the transit time of the respective sound direction varies as a result of certain “acceleration and braking effects” (formulas 2.1 and 2.2). The higher the gas velocity and the smaller the angle to the flow direction, the more the transit times of the sound pulses differ.

Gas flow rate v is calculated from the difference between both transit times, independent of the sound velocity value. Therefore changes in the sound velocity caused by pressure or temperature fluctuations do not affect the calculated gas flow rate with this method of measurement.

Fig. 1 Functional principle FLOWSIC300

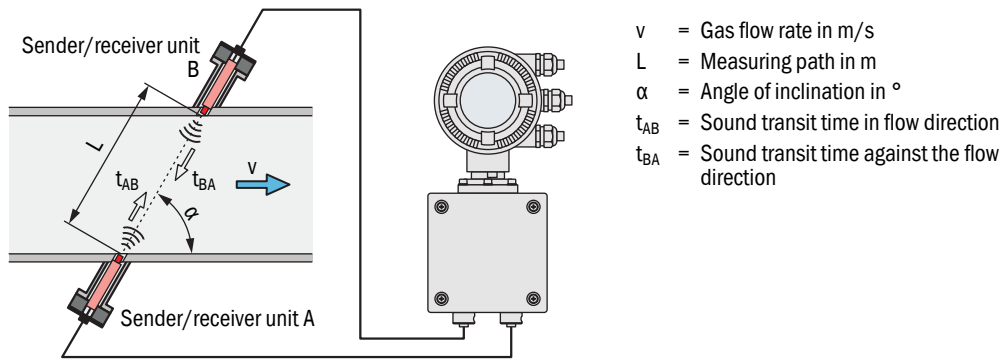

Determining the gas velocity

Measuring path L is equal to the active measuring path, that is, the area through which the gas flows. Given measuring path L , sound velocity c , and angle of inclination α between the sound and flow direction, the sound transit time in the direction of the gas flow (forward direction) when the signal is transmitted can be expressed as:

$$t_{AB} = \frac{L}{c + v \cdot \cos \alpha} \tag{2.1}$$

Valid against the flow is:

$$t_{BA} = \frac{L}{c - v \cdot \cos \alpha} \tag{2.2}$$

After the resolution to v :

$$v = \frac{L}{2 \cdot \cos \alpha} \cdot \left(\frac{1}{t_{AB}} - \frac{1}{t_{BA}} \right) \tag{2.3}$$

i.e. a relation in which, except for the two transit times measured, only the active measuring path and the path angle exist as constants.

Determining the sound velocity

Sound velocity *c* can be calculated by resolving formulas 2.1 and 2.2.

$$c = \frac{L}{2} \cdot \left(\frac{t_{AB} + t_{BA}}{t_{AB} \cdot t_{BA}} \right) \tag{2.4}$$

Based on the dependencies in formula 2.5, the sound velocity can be used to determine the gas temperature and molecular weight, and for diagnosis purposes.

$$c = c_0 \cdot \sqrt{1 + \frac{\theta}{273^\circ\text{C}}} \tag{2.5}$$

Calculating the gas temperature

Since the sound velocity is dependent on the temperature, the gas temperature can also be calculated from the transit times (by resolving formulas 2.4 and 2.5 to derive θ).

$$\theta = 273^\circ\text{C} \cdot \left(\frac{L^2}{4 \cdot c_0^2} \cdot \left(\frac{t_{AB} + t_{BA}}{t_{AB} \cdot t_{BA}} \right)^2 - 1 \right) \tag{2.6}$$

Formula 2.6 shows that, in addition to the measured transit times, the values of *L* and the sound velocity in standard conditions are also included in the calculation.

+i

- This means precise temperature measurement is only possible when measuring path *L* has been measured extremely accurately and a calibration has been carried out (see Section → p. 22, §2.1.3), and the gas composition is constant.
- The gas temperature calculated using formula 2.6 cannot be used to determine the volume flow rate in the standard state (→ p. 22, §2.1.3)

Calculating the volume flow rate

The volume flow rate in operating state is calculated from the gas velocity and the geometric dimensions of the pipeline.

Calculating the volume flow rate in the standard state is described in §2.1.3 (→ p. 22).

2.1.2

Measured variables

Measured variable	Abbrevia- tion	Unit	
		Display	MEPAFLOW600 CBM
Volume in operating conditions	Vf	m ³	m ³
Volume in standard conditions	Vb	m ³	Nm ³
Error volume in operating conditions	Ef	m ³	m ³
Error volume in standard conditions	Eb	m ³	Nm ³
Total volume, original	Vo	m ³	m ³
Volume flow rate in operating state	Qf	m ³ /h	m ³ /h
Volume flow rate in standard state	Qb	m ³ /h	Nm ³ /h

2.1.3 **Calculating and calibrating the volume flow rate**

Volume flow rate in operating state

The FLOWSIC300 is generally used to determine the volume flow rate in closed pipelines. Here, the uncorrected volume flow rate Q_{ac} is defined by representative cross-section A and mean gas velocity v_A with respect to the cross-section (surface velocity):

$$Q_{ac}^* = v_A \cdot A$$

Further factors, such as Reynolds number and flow profile must be considered for calculation of the actual flow rate Q_{ac} . A functional relation was introduced in FLOWSIC300 for calculation of the actual volume flow rate Q_{ac} :

$$Q_{ac} = Q_{ac}^* \cdot (1 + f[Q_{ac}^*, p_{abs}, CC_{0...4}, PF, K_{0...5}])$$

This functional relation has been implemented in the FLOWSIC300 as a calibration function with coefficients determined at the factory through reference measurement on a test bench and regression analysis, and then stored in the control unit. The coefficients for various nominal pipe diameters are parameterized during production of the device based on the specification of the planned nominal pipe diameter in the device.



An optional throughflow calibration supports improving coefficient precision and then entering in the measuring system. This can therefore further improve measuring precision.

Volume flow rate in standard state

The volume flow rate can be converted to the standard state as follows:

$$Q_{sc} = Q_{ac} \cdot \left(\frac{p_{pipe} \cdot T_{normal}}{p_{normal} \cdot T_{pipe}} \right) \cdot \frac{1}{\kappa}$$

Q_{ac} :	Volume flow rate in operating state
Q_{sc} :	Volume flow rate in standard state
p_{pipe} :	Absolute pressure in pipeline, normally set as parameter as fixed/default value typical for the plant. - If an optional analog module is used as an analog input for connecting a separate pressure sensor, the volume flow rate can be scaled with the current installation values.
p_{normal} :	1013 mbar
T_{pipe} :	Gas temperature (in K): Here in FLOWSIC300, either a permanent default temperature calculated with ultrasound measurement or read via the optional analog input (for greater accuracy) can be selected for use.
T_{normal} :	Standard temperature In Europe 273 K, in the USA 293 K
κ :	Compressibility (=1 for ideal gases); can be configured as a constant.

2.2 System configurations

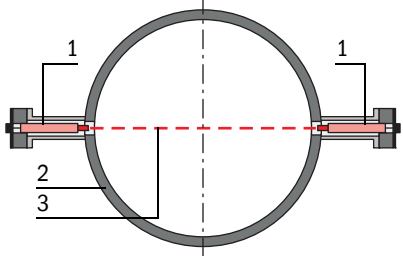
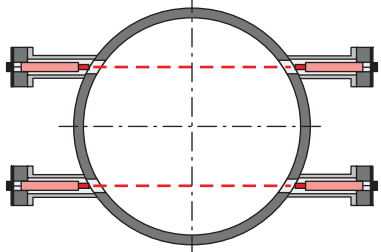
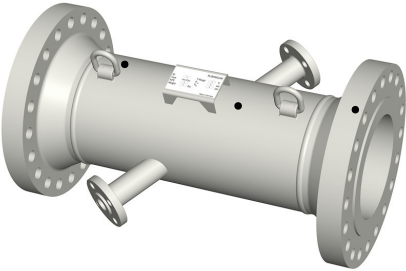
Configuration	Description	
1-path measurement	<p>Two sender/receiver units (1) are mounted on the pipeline (2). Measuring path (3) is positioned across the center of the pipeline.</p> <p>The 1-path configuration provides a cost-effective measuring solution, especially for nominal pipe diameters up to 12 inches.</p> <p>An uninterrupted flow profile is the prerequisite for a good measuring result. Monitoring and diagnosis functions requiring the adjustment of several ultrasonic paths are not available for 1-path configuration.</p> <p><i>Note:</i> Special operating conditions can make it necessary to position the path outside the pipeline center (shortens the measuring path).</p>	
2-path measurement	<p>Two pairs of sender/receiver units are installed at the same measuring location and are connected to the electronics unit.</p> <p>Both measuring paths should preferably be positioned outside the center of the pipeline and run parallel to one another.</p> <p>A measuring result from both measuring paths is calculated in the electronics unit.</p> <p>The 2-path configuration provides increased measuring precision and interference immunity. In addition, advanced monitoring and diagnosis functions are available for two ultrasonic measuring paths. The 2-path configuration can be used for nominal pipe widths from 12 inches.</p> <p><i>Path compensation:</i></p> <p>The device uses an integrated algorithm for path compensation in the case of a path failure.</p> <p>In trouble-free function, the system learns the relation of gas velocity and sound velocity between both measuring paths. In case of a path failure, the system can calculate theoretical values on the basis of the learned path relations and can replace the invalid values against them. In this way, the path failure can be temporarily compensated and measurement is continued with slightly increased uncertainty. Under such conditions, the measurement system automatically signals "Check request".</p>	
Pre-installation in piping (option)	<p>As an option, the 1- or 2-path configuration can be installed in a pipe section at the factory.</p> <p>Pipe sections with standardized flange connections (spools) or welding pipe sections can be realized in this configuration. This configuration provides the highest measuring precision and the lowest start-up effort due to the possible calibration in the factory and the preconfiguration of the electronics unit.</p>	



Special versions are available for difficult or narrow installation locations where both sender/receiver units are installed on the same side of the pipeline (principle: Sound reflection on the pipeline walls).

- Observe the individual device information provided on delivery.

2.3 **System overview**

2.3.1 **System components**

Fig. 2 FLOWSIC300 standard configuration (1-path measurement)

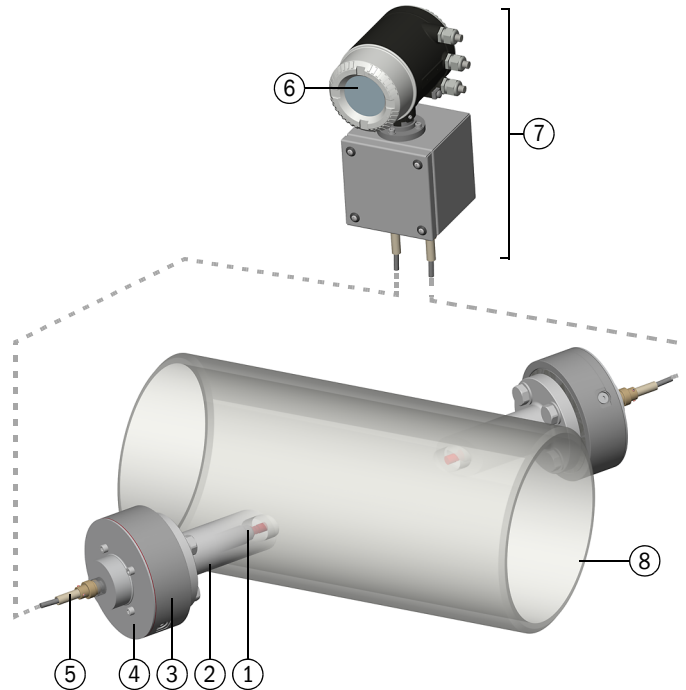

Pos.	Component	Quantity for	
		1-path measurement	2-path measurement [1]
1	Ultrasonic sensor	2	4
2	Nozzle		
3	Sender/receiver unit FLSE		
4	Cover		
5	Connection cable TNC-TNC (electronics unit cover)		
6	SPU (pivotable → p. 108, § 7.1.4)	1	1
7	Electronics unit		
8	Plant pipeline		

[1] Option.



- The nozzles are made individually for each order - tailored to the planned pipeline. An installation tool is supplied for assembly (→ p. 66, § 4.2.3).
- A complete spool piece with built-in fitted nozzles is available as an option which is then fitted in the pipeline (→ p. 29, § 2.5.1).

Options/accessories

Component
Spool piece (→ p. 29, § 2.5.1) [1]
Fitting tool for ultrasonic sensors (→ p. 30, § 2.5.2)

[1] Replaces nozzles and installation accessories for nozzles.

2.3.2

Sender/receiver units

Ultrasonic sensors optimally tuned to system requirements are fitted in the sender/receiver units of FLOWSIC300. The high quality of the sensor design provides the basis for accurate and highly stable transit time measurements with nanosecond precision. The ultrasonic sensors are designed electrically intrinsically safe, category “ia”.

The sender/receiver units and the ultrasonic sensors are marked on delivery. Installation on the pipeline must be carried out under consideration of the main throughflow direction according to the following Table to ensure correct measuring function.

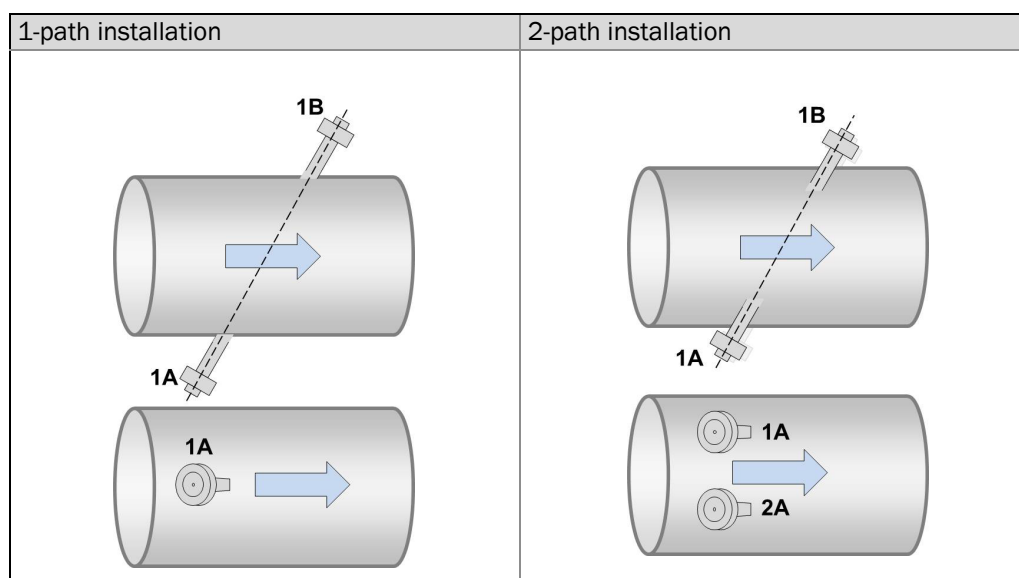

2.3.3 SPU

Function

The Signal Processing Unit (SPU) contains all the electrical and electronic components for controlling the ultrasonic sensors. It generates transmission signals and analyzes the received signals to calculate the measuring values. The SPU also contains several interfaces for communication with a PC or standardized process control system.

Current device states, errors, warnings and power failures are written to non-volatile memory (FRAM) with a timestamp (logbooks → p. 181, 12.5.) The last device state stored is set as start value for the volume counter when the system is started. The FRAM backup provides an unlimited number of writing cycles and guarantees saved data protection for a minimum of 10 years.

Design

The SPU is equipped with a front panel containing a two-line LCD to display current measured values, diagnostics and logbook information (→ Fig. 3). Selection using a magnetic pen is possible with the front cover closed. The MEPAFLOW600 CBM program supports user-friendly information displays.

Fig. 3 LCD front panel for FLOWVIC300

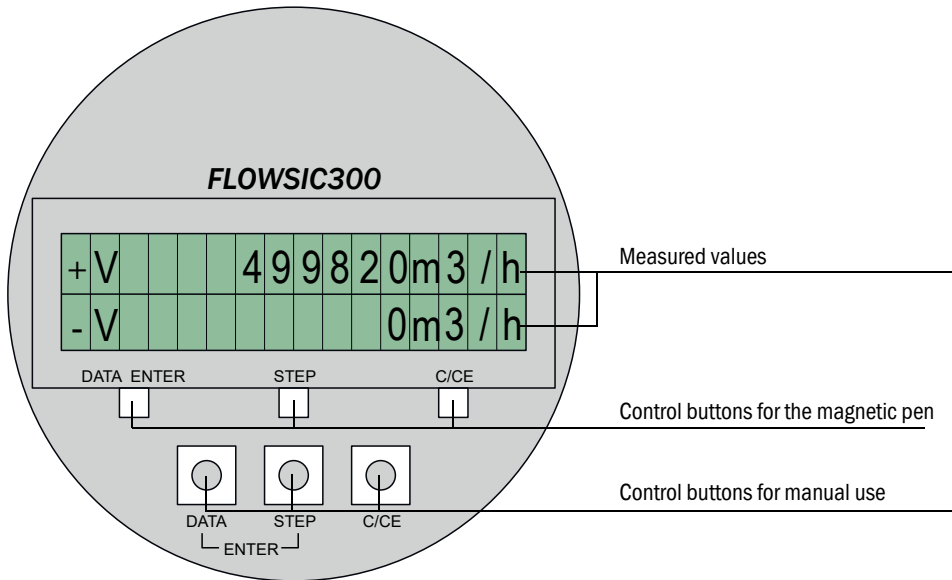

The power supply and interface terminals are located on the back of the SPU in a separate terminal compartment (→ p. 112, 7.2.4).

The electronics are fitted in an enclosure certified in accordance with EN 60079-1 or IEC 60079-1 with ignition protection type "d" – 'flameproof enclosure'. Sensor power circuits are intrinsically safe (category "ia").

2.3.4 Integration in the plant

Fig. 4 Integration in the plant (example Ex i)

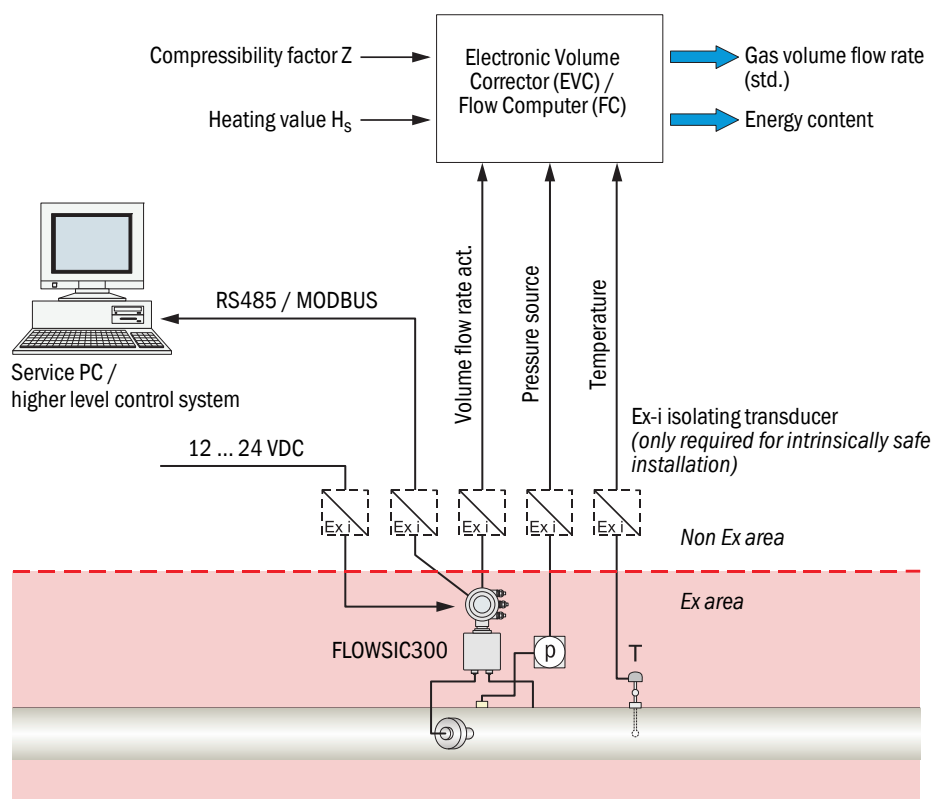

2.4

Scope of delivery**Measuring system**

Component	Quantity for	
	1-path measurement	2-path measurement [1]
Nozzle [2]	2	4
Ultrasonic sensor	2	4
Sender/receiver unit	2	4
Flat seal (sealing disc) for sender/receiver unit	2	4
Electronics unit	1	1
Connection cable	2	4

[1] Option.

[2] Not necessary when a spool piece is delivered (→ "Options/accessories").

Accessories

Component	Explanation
Foil strips to mark nozzle positions	→ p. 63, § 4.2.2
Installation tool for nozzles [1]	→ p. 66, § 4.2.3
Hand extraction tool for ultrasonic probes	
Handles for locking ring of sender/receiver unit	

[1] Not necessary when a spool piece is delivered (→ "Options/accessories").

Software

Component	Explanation
PC software MEPAFLOW600 CBM [1]	→ p. 46, § 2.11
Geometry tool [2]	→ p. 69, § 4.2.4

[1] Installation file on data medium (CD-ROM).

[2] Calculation Table on data medium (CD-ROM).

Options/accessories

Component	Explanation
Spool piece [1]	→ p. 29, § 2.5.1
Pressure measurement (pressure sensor, measuring line) [2]	
Temperature measurement (temperature sensor, measuring line) [2]	
Fitting tool for ultrasonic sensors	→ p. 30, § 2.5.2

[1] Replaces nozzles and installation tool.

[2] Only for spool piece (see separate information for specifications).

2.5 **Installation accessories**

2.5.1 **Spool piece**

Purpose

A FLOWSIC300 measuring pipe is a pipe piece (spool piece) for the gas line with the nozzles for the sender/receiver units already fitted. This means the precise welding work to fit the nozzles need not be done on-site.

Versions

- The following are designed according to the individual order: Nominal width, flange, material.
- The number of nozzles depends on the selected system configuration (→ p. 23, §2.2).
- The fitting length depends on the pipeline diameter (→ Fig. 5).

+i See the order documents or individual information provided on delivery for the spool piece version delivered.

Fig. 5 Spool piece (example)

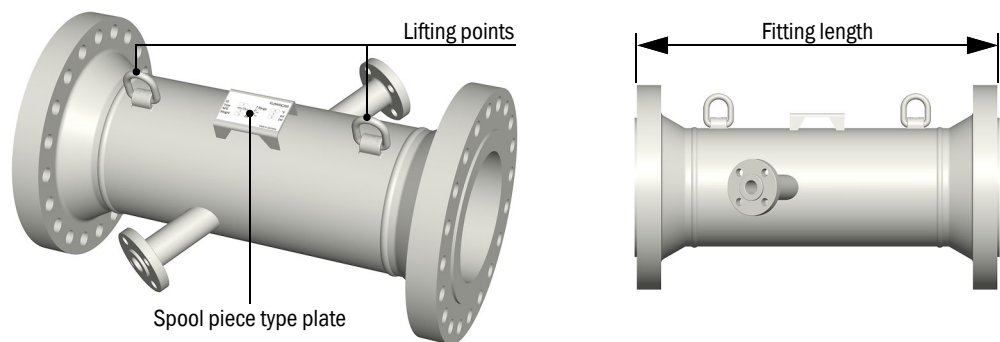

Pipeline diameter	Fitting length
≤ 24"	1000 mm
> 24"	1500 mm

+i ● The spool piece can be delivered with additional sensors fitted (→ "Options").
 ● Fitting the spool piece → p. 72, §4.3.

Options

All system solutions (FLOWSIC300 + spool piece) are optionally available with pressure and temperature sensors. The pressure and temperature measuring points are configured and positioned according to customer specifications

Additional options for spool pieces

- 3D measurement (minimizes geometric uncertainty)
- Flow-calibrated
- Version without flanges for welding into the pipeline (leak tightness must be checked after installation in pipeline)

2.5.2

Fitting tool

Purpose







The following work on the FLOW SIC300 can be carried out with the fitting tool without having to interrupt operation of the pipeline (at plant pressure):

- Drill holes for ultrasonic path in pipeline (→ p. 90, §6.3)
- Checking the ultrasonic sensors for damage or contamination
- Replacing the ultrasonic sensors

The fitting tool of the FLOW SIC300 is suitable for use with all sender/receiver units. The plant operator should have at least one fitting tool available for maintenance and service work.

It can be used with any number of FLOW SIC300 measuring systems.

Restrictions of use

	<p>WARNING: Explosion hazard</p> <p>The fitting tool is not approved for operation in explosive atmospheres. When used on the pipeline, risk of explosion must be excluded or a possible ignition hazard signaled in time by suitable means (e.g. monitoring with gas detector).</p>
	<p>WARNING: Fitting and removing the ultrasonic sensors in running operation (hot tap)</p> <ul style="list-style-type: none">● Only fit or remove the ultrasonic sensors in running operation with the optional fitting tool.● Only remove the ultrasonic sensors according to the instructions in the "Service Manual" for the FLOW SIC300.
	<p>WARNING: Pressure range for using the fitting tool</p> <ul style="list-style-type: none">● Fitting the ultrasonic sensors is possible in a pressure range from 0 ... 100 bar(g).● Removing the ultrasonic sensors is possible in a pressure range from 10 ... 100 bar(g).● Do not remove the ultrasonic sensors when the pressures are lower than 10 bar(g).
	<p>NOTICE:</p> <p>The fitting tool may only be used for natural gas and gas mixtures similar to natural gas. Use for other gases only on request.</p>
	<p>NOTICE:</p> <p>It is recommended to perform a technical check and maintenance on the fitting tool after 10 fitting tasks.</p> <p>The following tasks should be carried out at least:</p> <ul style="list-style-type: none">● Replacing the O-ring seal on the ball valve.● Functional check of the pressure gauge on the ball valve and on the hydraulic pump.● Functional check of the bypass and toggle valves.● Visual check of all welding seams on the hydraulic cylinder
	<p>NOTICE:</p> <p>It is recommended to check the fitting tool after 100 fitting tasks or 5 years with a strength test according to Annex I Section 7.4 of Directive 2014/68/EU.</p>

2.5.2.1 Pressure gauge on ball valve

	NOTICE: Before each change: Check the function of the pressure gauge on the ball valve, → p. 89, §6.2.5.
---	--

Fig. 6 Labeling of the pressure gauge on the ball valve/safety markings

	WIKAI	CE	⚠	→	📖		
	Type DG-10-E	S# 2046565					S# serial number
Measuring range	0..400 bar						
Auxiliary power	2xAA LR6 1,5V	P# 13327235					P# product number
www.wika.de							

Components

Fig. 7 Fitting tool

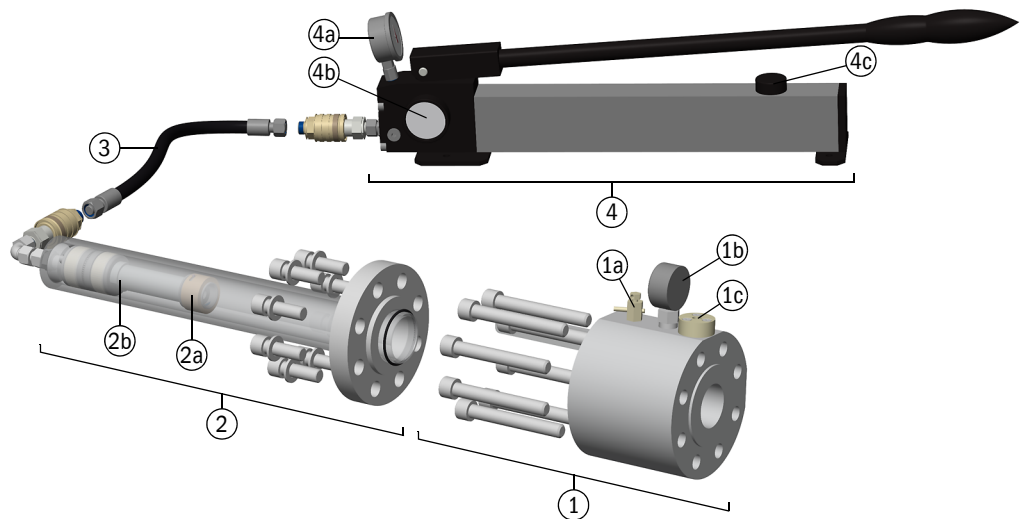

Pos.	Component	Pos.	Subcomponent
1	Ball valve	1a	Toggle valve
		1b	Pressure gauge for gas pressure
		1c	Bypass valve
2	Hydraulic cylinder	2a	Coupling
		2b	Hydraulic piston
3	Hydraulic hose		
4	Hydraulic pump	4a	Pressure gauge for hydraulic pressure
		4b	Pressure valve
		4c	Oil tank cap

Functional principle

The ball valve is fitted on the locking ring and then the hydraulic cylinder fitted. Ball valve and hydraulic cylinder form a pressure lock. The ball valve valves serve to compensate the pressure. When the ball valve is open, the hydraulic cylinder can push or pull an ultrasonic sensor in or out of the nozzle.

The hydraulic cylinder coupling can be set to “fit” or “remove”. The coupling engages into the ultrasonic sensor during removal; during fitting, the ultrasonic sensor is only pushed without engaging (→ p. 86, §6.2.3).



Instructions on the fitting tool → p. 83, §6

2.6 **Output configurations**

2.6.1 **Hardware variants and signal outputs (I/O configuration)**

FLOWSIC300 outputs are available in various configurations. Different output configurations require different hardware variants of the electronics unit (→ p. 34, Table 1).

Fig. 8 Terminals in FLOW SIC300 SPU (cover open)

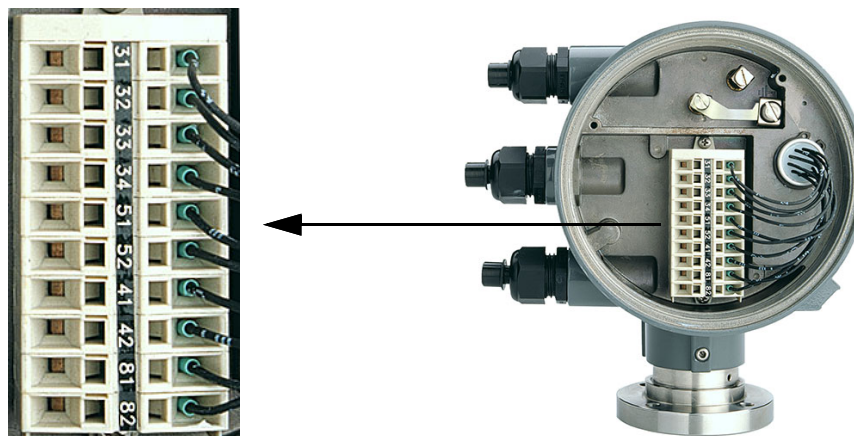

The following settings can be assigned to the four available physical outputs (the actual RS485 MODBUS communication port 33/34 is not considered to be an output). The settings can be configured on the “Device parameters” page and in the Field setup wizard of the MEPAFLOW600 CBM software.

Digital output	Possible settings
Output D00 (31/32)	Warning, data invalid, flow direction, check request AO output 4 .. 20mA or 4 .. 20mA with serial HART® [1]
Communication (33/34)	Communication port RS485 MODBUS [2] (fixed)
Output D01 (51/52)	Pulse
Output D02 (41/42)	Warning, data invalid, flow direction, check request
Output D03 (81/82)	Warning, data invalid, flow direction, check request

[1] See document “HARTbus Specification” for further details on HART®; document available on request.

[2] See document “Short Manual MODBUS” for more details on RS485, document available on request.

Table 1 Available hardware variants / output configurations

Hardware variant/Output configuration				
Analog board	HV [1]	3 (1/3)	5 (2/4)	C(6/10)
	EVC	Without	Without	With
Output terminal	31/32	Status	Analog/ HART	EVC int. PS
	33/34	RS485	RS485	RS485
	51/52	Pulse	Pulse	Pulse
	41/42	Status	Status	Status
	81/82	Status	Status	Status

[1] Hardware variants, internal keys

2.6.2 Behavior of the analog output (absolute value creation/linear)

In the standard setting, the analog output of the FLOWSIC300 always signals the level of the measured flow rate, independent of the flow direction, as shown in → Fig. 9 (“absolute value creation behavior”). This behavior can be changed by Endress+Hauser Service at the factory or on request.

Fig. 9 Absolute value creation behavior (example)

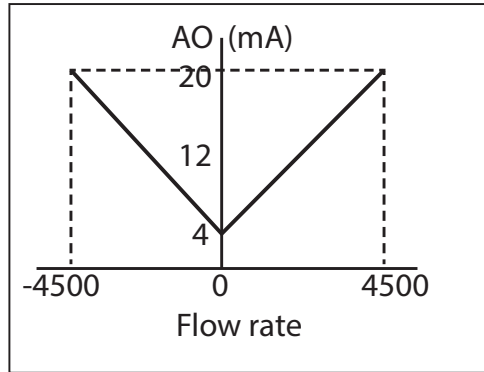

Example:
AO range low = 0
AO range high = 4500

When the measured value is higher than +AOHigh (positive flow direction) or lower than -AOHigh (negative flow direction), the AO maximum value 20 mA is output instead of the calculated AO value.

When a value other than zero is configured in the device for “AO range low” (Register #7028, Menu Parameter/Device parameters in operating software MEPAFLOW600 CBM), the analog output follows a linear behavior, → Fig. 10.

Fig. 10 Linear behavior

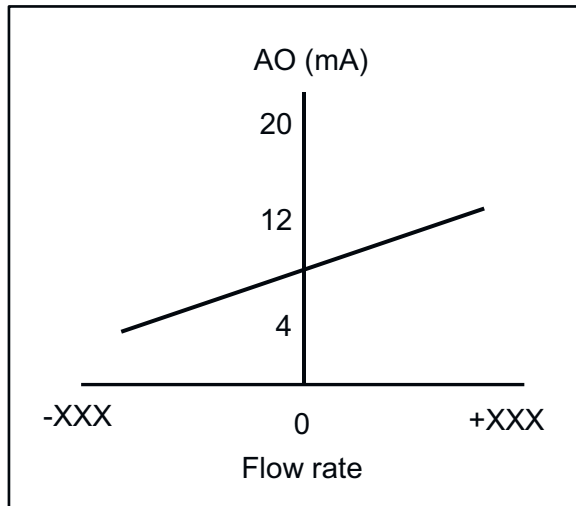

2.7 Wiring of digital outputs

The digital output (terminals 31/32, 51/52, 41/42, 81/82) can be wired as Open Collector or as NAMUR contact for connection to a NAMUR amplifier.

The outputs are wired in accordance with “NAMUR” on delivery, unless “Open Collector” was specified in the purchase order.

Fig. 11 Wiring of digital outputs

Open Collector

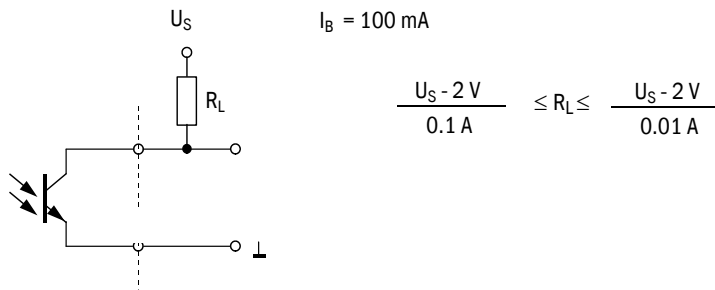

NAMUR

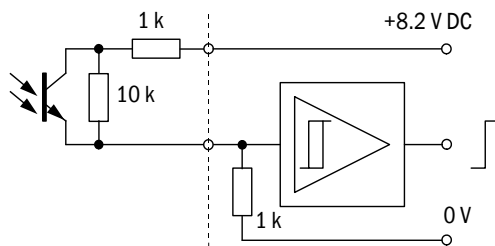

NOTICE:

- An operating current range of 20 mA is recommended.
- I_{max} at the open collector connection must not exceed 100 mA., otherwise the output may be destroyed.
- The maximum possible frequency of the impulse output depends on R_L and the cable length (cable capacitance).
- A higher frequency requires a lower R_L . For this case a low capacitance cable is recommended.

2.7.1

Hardware variant C(6/10) with integrated electronic volume corrector (EVC)

Hardware variant C(6/10) has an integrated electronic volume corrector.

FLWSIC300 supports three different algorithms for gas volume correction. Alternatively the option “Fixed values” can be used.

SGERG88	Usable up to a pressure of 100 bar (1450 psi).
MR113-3	Algorithm developed in Russia and recommended for use in the Russian petroleum market for wet gases (flare gas) in a temperature range of -10 °C .. 230 °C at pressures up to 150 bar.
GERG91 mod	Recommended for correction of dry natural gas in Russia.
Alternative option “Fixed values”	Alternatively, the user can choose to calculate the molar mass using the measured sound velocity and the gas temperature recorded as fixed or actual value.

See document “FLWSIC600 Technical Bulletin: EVC” (available from your local representative) for detailed information on the EVC.

2.8 **Operating modes and signal output**

The FLOW300 has the following operating modes (→ 2.8.1):

- Operation mode
- Configuration mode

The device can have the following device status in measuring operation (→ 2.8.2):

- Measurement valid
- Check request
- Data invalid

2.8.1 **Operation mode and Configuration mode**

The FLOW300 can be used in two modes: Operation mode or Configuration mode.

Operation mode

In Operation mode, the FLOW300 runs in one of the three device statuses depending on the measuring conditions.

Configuration mode

Configuration mode serves to modify parameters that directly influence measurement and to test the system and output signals. Configuration mode forces the device to status “Data invalid”. Digital output “Measurement valid” is deactivated because invalid measured values can occur in Configuration mode. The system continues operation using the current sample rate and executes all calculations as in measuring operation. Frequency output and analog output may be set to test values and do thus not necessarily indicate measured values. Apart from the parameter measuring rate and ModBus interface/device address baud rate, all parameter changes are considered immediately in running calculations.



The device switches automatically to Operation mode when the device is in Configuration mode and no activities occur for longer than 15 minutes on the LCD display or via MEPAFLOW600 CBM.

Check cycle

Setting the associated control bit in the system control register (#3002) allows activating a check cycle on a measuring path (the setting can be made on page “Device parameters” in MEPAFLOW600 CBM). Here, the send signal is coupled into the receive amplifier of the measuring path via an electric attenuator (= sensor simulator). This function can only be activated when Configuration mode is activated. It is only useful when testing path electronics.

Any existing check cycles are deleted automatically when Configuration mode is terminated.

2.8.2 **Device status**

2.8.2.1 **Status: Measurement valid**

Status “Measurement valid” is the normal device status of the FLOWSIC300. Frequency output and current output are updated cyclically and deliver the volumes and actual volume flow rate. Apart from that, the analog signal can display the actual volume flow rate, the corrected volume flow rate, the sound velocity (SOS) or the gas velocity (VOG). The digital output “Direction of flow” is updated in accordance with the direction of the volume flow. The digital output “Measurement valid” (active) represents the status of the measurement. Positive (forward) and negative (reverse) volume flow rates are integrated and saved in separate internal memory sections.

The ModBus interface serves to inquire all parameters and signals at any time without influencing system functions.

Each measurement initiated by the system controller includes one full transit time measurement with, and one against the direction of flow on each path. The result of each measurement is written to a mean value memory to be used in further calculations. The size of this memory block and thus the device response delay can be modified through the parameter in register #3502 “AvgBlockSize”. If no result can be calculated due to poor signal quality, this measurement is registered as an invalid attempt in the mean value memory. The mean value is formed in a variable averaging process including all valid measured values in the memory.

The measuring system switches to status “Check request” when the number of invalid measurements in one path exceeds the prescribed threshold (parameter register #3514 “LimitError”).

2.8.2.2 **Status: Check request**

This status is active when one of the two measuring paths of a 2-path system has failed and the adaptive path failure compensation is activated. This failure is compensated on a FLOWSIC300 in 2-path configuration. Measurement continues with slightly lower precision. The measuring system switches to status “Data invalid” when the measuring path of a 1-path system fails or path compensation of a 2-path system is deactivated.

Status “Check request” is also active when system alarms 2002 (“No HART communication with temperature sensor”), 2003 (“No HART communication with pressure sensor”) or 2004 (“Maximum pulse output frequency exceeded”) are active (see Table → p. 181, 12.5.1).

2.8.2.3 **Status: Data invalid**

If the quality of the signals received from all measuring paths is insufficient, the device marks the measured value as invalid and activates device status “Data invalid”. However, the SPU will cyclically attempt to reestablish valid measurements. As soon as the signal quality and the number of valid measurements allow it, the device switches automatically back to status “Measurement valid” or “Check request”.

2.8.3 Signaling pulse output and state

Output signal / LCD / port		Signal behavior												
		Measurement	Check request	Configuration mode	Data invalid [1]									
Pulse output signals	Single pulse output													
"Check request" Status signal	Status "active / inactive" [2] Measurement valid	Status "active / inactive" [2] Compensation of path failure	"Undefined"	"Undefined"										
"Flow direction" Status signal	Status "active / inactive" [2] Positive or negative direction of flow	Status "active / inactive" [2] Positive or negative direction of flow	"Undefined"	"Undefined"										
"Warning"	Status "active / inactive" [2]	Status "active / inactive" [2]	"Undefined"	"Undefined"										
LC-Display	<table border="1"> <tr> <td>+V</td> <td>123456 m³</td> </tr> <tr> <td>-V</td> <td>1234 m³</td> </tr> </table>	+V	123456 m ³	-V	1234 m ³	<table border="1"> <tr> <td>1234 m³</td> </tr> </table> <p style="text-align: center;"><i>Display blinks</i></p>	1234 m ³	<table border="1"> <tr> <td>FLOWSIC300 Configuration</td> </tr> </table>	FLOWSIC300 Configuration	<table border="1"> <tr> <td>+V</td> <td>123456 m³</td> </tr> <tr> <td>-V</td> <td>1234 m³</td> </tr> </table> <p style="text-align: center;"><i>Display blinks</i></p>	+V	123456 m ³	-V	1234 m ³
+V	123456 m ³													
-V	1234 m ³													
1234 m ³														
FLOWSIC300 Configuration														
+V	123456 m ³													
-V	1234 m ³													
Serial port RS485	<ul style="list-style-type: none"> Measured value, diagnosis information and parameters Measuring data logging, diagnosis and configuration using the MEPAFLOW600 CBM program Connection with external process control equipment through implemented MODBUS protocol (data polling) 													

[1] The device can be configured so that it outputs a fixed frequency for "Data invalid". The frequency to be output in this case can be configured (0-6 kHz) in Reg. #3034 "ErrorFreq".

[2] State "active" or "inactive" can be assigned to the electrical switching state "normal open" or "normal closed" using the configuration in the MEPAFLOW600 CBM program (settings for register #5101 on page "Parameters").

- Standard setting for "Check request", "Configuration" and "Data invalid" is "normal closed".
- Measured values, parameters, messages and other information can be displayed on the LCD display.
- A blinking character in the top right corner of the LCD display indicates that a logbook contains unacknowledged logbook entries. Depending on the type of entry this will be:
 - "I" – Information
 - "W" – Warning
 - "E" – Error
 The blinking character disappears when all new entries have been acknowledged. For details see → p. 158, 9.7.1.

2.9 **Self-diagnosis with user warnings**

During normal operation, the ratios of sound and path velocities, amplification values, performance, and signal-to-noise ratios are continuously monitored. If these values exceed set limits (customized User Warning limits), a warning signal will be generated. This allows immediate measures to be taken to address a problem which could potentially impact measurement quality.

A message in the Warning Logbook documents the time of the event and the specific User Warning limit which was exceeded.

-  • The “Warning” signal does not affect the functionality of the meter.
- All User Warning parameters - except for the parameter “Min. VOG for warnings” - can be configured in the User Access Level “Operator” and without switching the meter to the Configuration Mode.

A User Warning becomes active only if a User Warning limit has been continuously exceeded for a certain time (specified in the parameter “Warning duration and averaging for warnings” in the Configuration tab of User Warnings).

During commissioning or operation, the User Warning limits can be adapted and activated or deactivated in the “User Warnings” window in MEPAFLOW600 CBM to suit individual application requirements.

Fig. 12 Button “User” in the MEPAFLOW600 CBM main system bar, “User Warnings” window

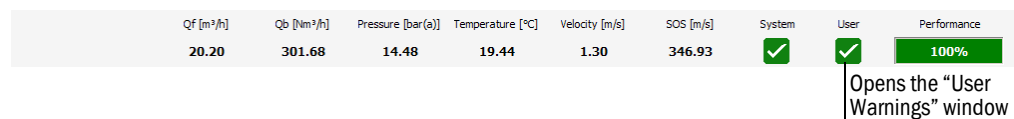

System warnings

Path warnings

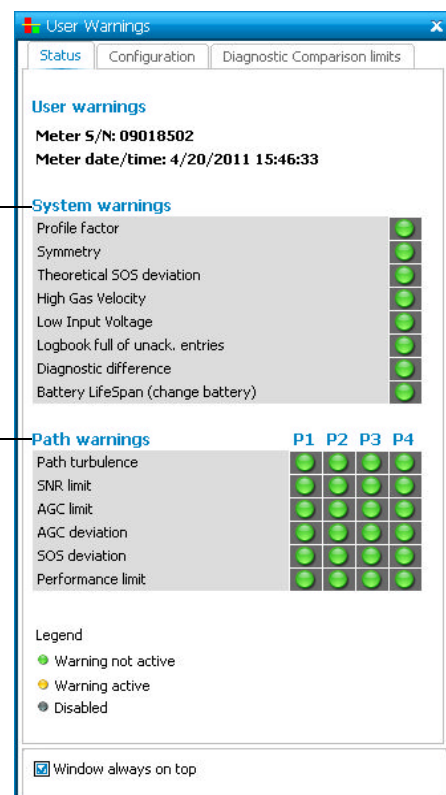

2.10 Data handling in the FLOWSIC300

2.10.1 Integrated volume counters

The FLOWSIC300 is equipped with integrated volume counters which can be displayed both on the LCD display and in MEPAFLOW600 CBM.

Integrated volume counters

Volume counter	Abbreviation
Volume at flowing conditions (forward)	+ Vf
Volume at flowing conditions (reverse)	- Vf
Error volume at flowing conditions (forward)	+ Ef
Error volume at flowing conditions (reverse)	- Ef
Total volume at flowing conditions (forward)	+ Vo
Total volume at flowing conditions (reverse)	- Vo
Total volume at flowing conditions (all)	Vo

Last hour/day registers

Volume counter	Abbreviation
Forward volume of last hour	Last hour forw.
Reverse volume of last hour	Last hour rev.
Forward volume of last day	Last day forw.
Reverse volume of last day	Last day rev.

Additional counters in meters with integrated Electronic Volume Corrector (EVC)

Volume counter	Abbreviation
Volume at base conditions (forward)	+Vb
Volume at base conditions (reverse)	- Vb
Error volume at base conditions (forward)	+ Eb
Error volume at base conditions (reverse)	- Eb

Mass counters

Mass counter	Abbreviation
Mass counter (forward)	+ M
Mass counter (reverse)	- M
Mass total (forward)	M+
Mass total (reverse)	M-
Error mass (forward)	Me+
Error mass (reverse)	Me-

2.10.2

Logbooks

Important system events are stored in three logbooks in the SPU memory of the meter. Each logbook entry consists of a running index number, the event, a time stamp and the acknowledgement status. Entries in Custody logbook [1] and Warning logbook [2] also include the volume counter readings valid at that time. The events are logged continuously in order of occurrence into one of the three logbooks:

- Logbook 1 (Custody logbook [1], max. 1000 entries)
- Logbook 2 (Warning logbook [2], max. 500 entries)
- Logbook 3 (Parameter logbook [3], max. 250 entries)

Every logbook has its own index counter. Logbook entries are classified on the LCD display according to the event type.

Event types in logbooks

Display	Event type
E	Error
W	Warning
I	Information

All logbooks of FLOWSIC300 are configured to ring buffer mode when delivered. This means the index number continues increasing, and after the logbook has reached its maximum number of entries, each new entry overwrites the oldest entry.



The logbooks can also be configured so that the volume counters stop when Custody logbook [1] and/or Parameter Logbook [3] are full. In this case, meter state “Data invalid” will be activated until the corresponding logbook has been saved and deleted.

Index counter overflow

The index number displayed in the LCD display runs up to 9999 and then overflows. In case of an index overflow, all logbook entries are deleted and all logbook index counters reset.

Acknowledging entries

Each entry can be acknowledged manually on the LCD display as well as in MEPAFLOW600 CBM. It is possible to acknowledge individual entries or all entries at once.

2.10.3 DataLogs^[1]

FLAWSIC300 has two DataLogs (Hourly Log and Daily Log). They save averaged measured values and are stored in the SPU's non-volatile memory (FRAM). All data can be downloaded and exported to Excel files with MEPAFLOW600 CBM.



The following sections describe the default configuration of the DataLogs. The DataLogs can be configured to best suit your application.

2.10.3.1 Hourly Log

The Hourly Log logs hourly diagnostic values by default (dataset type "Diagnostic Values") for the forward flow. As long as the flow is valid and the VOG is above Vmin all diagnostic and flow values are averaged over one hour and saved every full hour. The Hourly Log stores these values for more than a month (38 days) by default. They are then overwritten with new values.

2.10.3.2 Daily Log

The Daily Log logs the daily diagnosis values by default (dataset type "Volume Counters") for the forward flow. All flow values are averaged over one day and saved at the (configurable) Accounting Hour. The Daily Log stores these values for approximately 2 years by default (1 year and 361 days). They are then overwritten with new values.

DataLog storage cycle

Hourly Log and Daily Log can be configured to save entries in a storage cycle of: 3 min, 5 min, 15 min, 30 min, 1 hour, 12 hours or 24 hours.

If a DataLog is set to a Storage cycle of 12 or 24 hours, the accounting hour takes effect.

2.10.3.3 DataLog storage behavior

Hourly Log and Daily Log can be configured for the following storage behavior:

- Overflow (Default)
- Stopping



Storage Behavior "Stopping"

If a DataLog is configured with the storage behavior "Stopping", a warning will be shown in the Meter Status Table when the DataLog is full.

2.10.3.4 Types of datasets stored in the DataLogs

Hourly Log and Daily Log can be configured to store one of the following type of dataset:

- Diagnostic values
- Volume counter
- Standard Volume Counters
- Mass Flow Counters

[1]This feature may be deactivated. Please contact your Endress+Hauser representative.

2.10.4 **Diagnostics Comparison Log^[1]**

The Diagnostics Comparison Log provides a comparison between current diagnostic values (current fingerprint) and those of a reference time (reference fingerprint, for example, at time of commissioning). Since the diagnostic values are velocity-dependent, it is necessary to use a velocity-adaptive comparison. Five gas velocity range classes are calculated from the velocity range of the meter. The current diagnosis values are stored in Current Classes 1 to 5, while the reference values are stored in Reference Classes 1 to 5.

Reference values are collected after the meter has been commissioned or after the classes have been cleared. Reference values are stored in the Reference Classes 1 to 5. If a Reference Class is filled with an entry, the next valid entry is stored into the same velocity range but in the corresponding Current Class (e.g. if Reference Class is filled, the next value from within this velocity range will be stored in Current Class 1). During operation, the Current Classes are continually overwritten with new entries. The Reference Classes stay unchanged until they are manually cleared.

Per default the Diagnostics Comparison Log operates bidirectional, saving separate data for both flow directions. The values are stored in the gas velocity classes 1 to 5, depending on the gas velocity.

Fig. 13 Diagnostics Comparison Log

Selected entry:

System state	Limits	Path Error
<input type="checkbox"/> System rebooted	<input type="checkbox"/> User Warning exceeded	<input type="checkbox"/> Path 1
<input type="checkbox"/> Measurement invalid	<input type="checkbox"/> Max. VOG exceeded	<input type="checkbox"/> Path 2
<input type="checkbox"/> Meter in Configuration Mode	<input type="checkbox"/> Max. pulse frequency exceeded	<input type="checkbox"/> Path 3
<input type="checkbox"/> Check request	<input type="checkbox"/> Input voltage warning	<input type="checkbox"/> Path 4
Logbooks (Custody, Warning)	EVC-Status	
<input type="checkbox"/> Full of unack. entries	<input type="checkbox"/> EVC Parameter Error	
<input type="checkbox"/> Contains unack. entry	<input type="checkbox"/> EVC Hardware Error	

Number	Class type	Direction	Class limits	Date (Ending)	Time (Ending)	Flow Time [%]	AvgVOG [m/s]	AvgSOS [m/s]	ProfileFactor [-]	Symmetry [-]	Performance
1	Ref. Class	Forward	0.3m/s...0.5m/s	4/13/2011	10:06	100.00	0.43	345.21	1.323	0.990	
2	Ref. Class	Forward	0.5m/s...0.8m/s	4/13/2011	09:59	100.00	0.51	345.18	1.293	0.971	
3	Ref. Class	Forward	0.8m/s...1.4m/s	4/11/2011	15:04	100.00	0.90	346.34	1.277	1.026	
4	Ref. Class	Forward	1.4m/s...2.6m/s	4/6/2011	10:46	100.00	2.40	346.34	1.199	1.003	
5	Ref. Class	Forward	2.6m/s...5.0m/s	4/6/2011	13:24	100.00	3.45	346.13	1.187	0.984	
1	Cur. Class	Forward	0.3m/s...0.5m/s	4/13/2011	10:26	100.00	0.38	345.40	1.361	0.991	
2	Cur. Class	Forward	0.5m/s...0.8m/s	4/13/2011	10:02	100.00	0.47	345.18	1.318	0.978	
3	Cur. Class	Forward	0.8m/s...1.4m/s	4/12/2011	15:19	100.00	0.85	344.30	1.252	0.980	
4	Cur. Class	Forward	1.4m/s...2.6m/s	4/11/2011	15:02	100.00	2.09	346.42	1.219	1.032	
5	Cur. Class	Forward	2.6m/s...5.0m/s	4/29/2011	13:58	100.00	3.47	346.02	1.197	0.992	

[1] This feature may be deactivated. Please contact your Endress+Hauser representative.

2.11 **MEPAFLOW600 CBM**

2.11.1 **Software installation**

System requirements

- Microsoft Windows XP/Windows 7
- Min. 1 GHz CPU
- Min. 512 MB RAM
- USB or serial interface
- Screen resolution min. 1024 x 768 pixels (ideal display resolution 1280 x 1024 pixels)

Compatibility

MEPAFLOW600 CBM can be used with all firmware and hardware versions of the FLOW-SIC300. Availability of software functions depends on the firmware version of the connected FLOW-SIC300.

Installation

A product CD with the MEPAFLOW600 CBM program is delivered with the FLOW-SIC300. Insert the product CD into your CD-ROM drive to install the software. Start file 'FLOW-SIC300_R_CD.exe' to install the program.

Access to most of the data delivered by the FLOW-SIC300 (such as displays, logbook entries and parameters) can be made using the LCD display of the device. However, the MEPA-FLOW600 CBM software provides a more user-friendly access to diagnostic, configuration and measurement data of the flow meter.

2.11.2 Overview

The MEPAFLOW600 CBM program provides a menu-based user interface with many functions for diagnosis of the FLOWSIC300. It allows access to all system parameters, displays diagnostic information in diagrams and graphs, generates reports (e.g. Status reports) and data files (recordings, logs) that can be exported for data evaluation. Its device database serves to manage parameters, reports, session files and logbooks both online and offline.

Fig. 14 MEPAFLOW600 CBM graphical user interface

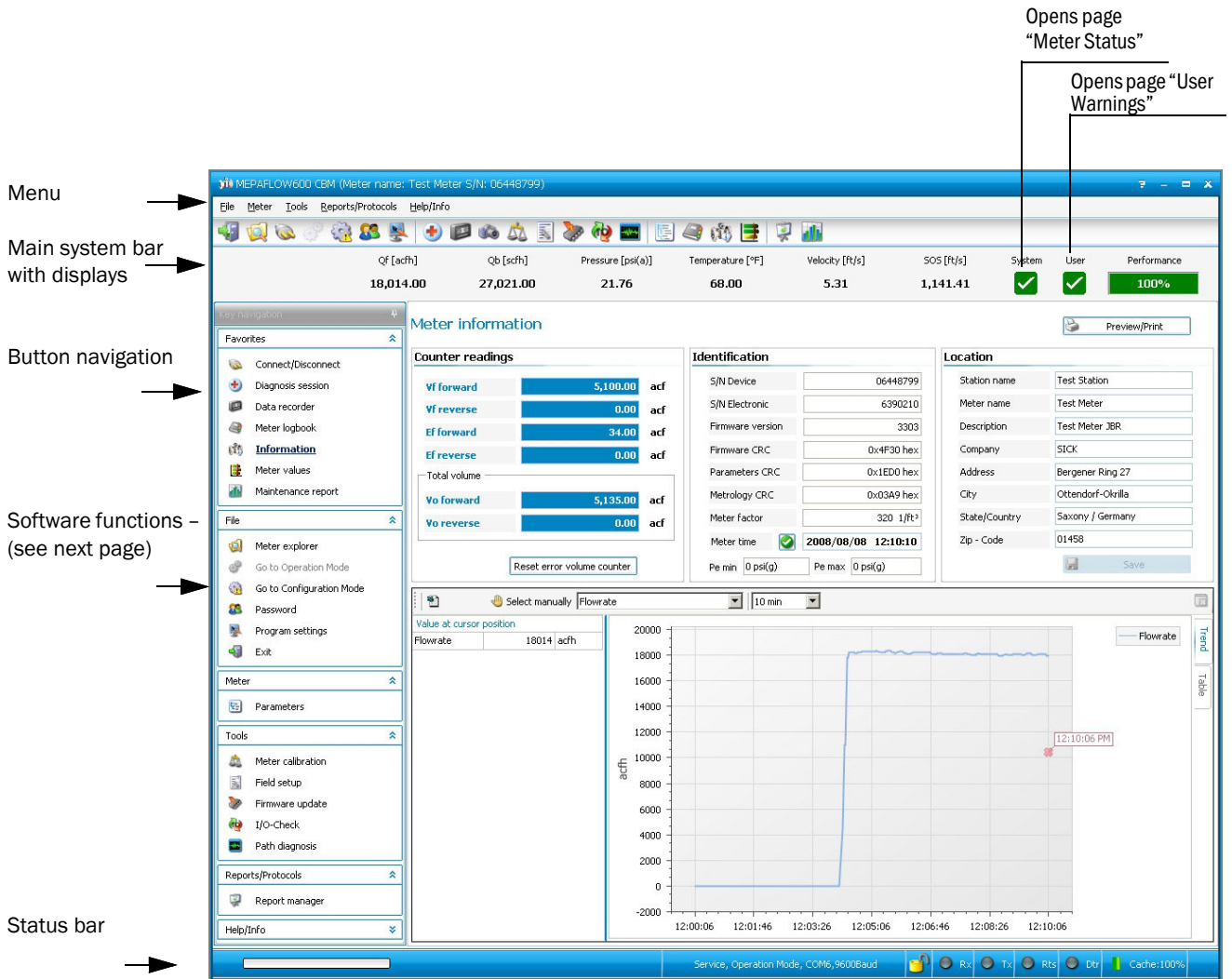

Software Features

Main readings bar	Description
Meter Status	Window displaying the current Meter Status.
User Warnings	Window for the display of the User Warnings and for the configuration of the User Warning Limits and the Diagnostic Comparison Limits.
Button navigation	Description
Connect/Disconnect	Assistant for establishing online and offline connections between MEPAFLOW600 CBM meter database and FLOWSIC300.
Diagnosis session	Quick creation of session files for diagnostic purposes.
Data recorder	Tool for the recording and playback of current, future or cached readings.
DataLogs	Access to Hourly Log, Daily Log and Diagnostics Comparison data saved in the meter. Data can be exported to Excel. The Diagnostics Comparison Report can be printed or exported as PDF.
Logbook	Access to meter logbook and logbook entries saved to meter database.
Overview	Overview of higher level meter information: Counter readings, identification and location of meter and display of readings (e.g. flow rate) in graph.
Meter values	Detailed diagnostic page with graphs for velocity of gas, speed of sound (SOS), path performance, AGC, signal-to-noise-ratio (SNR), turbulence, profile symmetry and user selectable readings (e.g. flow rate). Summary of device status.
Maintenance report	Assistant for the creation of Maintenance reports.
Meter explorer	Overview, access and management of the meter database saved on the PC. Includes all meter data and sessions with entries for all changes of parameters, changes of the operating mode, measurement records (including diagnosis sessions) and maintenance reports. Functions for export, import, creation and deletion of meter data.
Go to Operation Mode / Go to Configuration Mode	Operation Mode switches: "Operation Mode" for normal operation or "Configuration Mode" for writing information (i.e. parameters) to the meter.
Program settings	Access to program settings for the individual adjustment of the program appearance and setup (e.g. settings for file path, memory, unit system and layout).
Parameters	Access to all meter parameters. Assistant for comparing current parameter settings with previous ones.
Save cache	Saves the historical data from the PCs memory (cache) to a record.
SOS Calculator	A theoretical SOS can be calculated for a specific gas composition.
Meter calibration	The calibration wizard guides the user through the calibration procedure with automated processes to write the information to the meter and generate reports.
Field setup	The field setup wizard guides the user through the commissioning procedure.
Firmware update	Assistant for installing firmware updates.
I/O check	The I/O check wizard guides the user through a test of all meter outputs.
Path diagnosis	Access to path diagnosis and graphs of received signals.
Report manager	Overview, access and management of all reports stored in the meter database. The report manager enables the creation of Trend reports from saved records and maintenance reports.

FLOWSIC300

3 Preparing for installation

Overview

Project planning

Installation location requirements

3.1

Overview of installation work

A Preparations		
	Work step	Information/instructions
1	Observe the individual device information delivered with the device	
2	Determine the measuring location (position of sender/receiver units)	→ p. 52, § 3.2.2
3	Determine the installation location for the electronics unit	→ p. 106, § 7.1.2

B Installing sender/receiver units in running operation (hot tapping)		
	Work step	Information/instructions
1	Install nozzles on pipeline	→ p. 59, § 4
2	Install sender/receiver units	→ p. 90, § 6.3
3	Drill holes for ultrasonic path in pipeline by means of “hot tapping” method ^[1]	→ p. 90, § 6.3
4	Install ultrasonic sensors using the fitting tool	→ p. 95, § 6.5

[1] Requires special machines (hot tapping tool) and special technical knowledge. This work is not described in these Operating Instructions and the manufacturer is not responsible for implementation. *Recommendation:* Have this work carried out by a specialist company.

Or:

B Installing the sender/receiver units when operation idle		
	Work step	Information/instructions
1	Install nozzles on pipeline	→ p. 59, § 4
or:	Install spool piece in pipeline (<i>Option</i> → p. 29, § 2.5.1)	→ p. 72, § 4.3
2	Drill holes for ultrasonic path in pipeline	
3	Install sender/receiver units	→ p. 75, § 5
4	Install ultrasonic sensors (without fitting tool)	→ p. 75, § 5

C Installing the electronics unit		
	Work step	Information/instructions
1	Fit electronics units	→ p. 106, § 7.1
2	Electrical installation	→ p. 109, § 7.2
3	Install connection cable to the sender/receiver units	→ p. 108, § 7.1.5

D Carrying out initial start-up		
	Work step	Information/instructions
1	Connect electronics unit to a PC	→ p. 126, § 8.2
2	Connect electronics unit to MEPAFLOW CBM	→ p. 128, § 8.3
3	Perform Field setup wizard or manual start-up	→ p. 134, § 8.5

3.2 **Project planning**

3.2.1 **Project planning checklist**

The following Table provides an overview of the project planning work to be carried out to ensure the device is correctly installed and fully functional. You can use this Table as a checklist and tick off all the steps you have carried out.

Task	Requirements		Work step	<input checked="" type="checkbox"/>
Determine measuring location (→ p. 52, §3.2.2)	Flow distribution, inlet and outlet paths	Lowest possible influence on measuring precision	Follow specifications for new equipment; select best possible location for existing equipment	<input type="checkbox"/>
	Accessibility, accident prevention	Easy and safe	Provide platforms or pedestals when necessary	<input type="checkbox"/>
	Vibration-free installation	Accelerations < 1 g	Take appropriate measures to eliminate/reduce vibrations	<input type="checkbox"/>
	Ambient conditions	Limit values → p. 179, § 12.2	If necessary: Provide weatherproof covers / sun protection, enclose or insulate device components.	<input type="checkbox"/>
Select device components	Installation locations	Cable lengths		<input type="checkbox"/>
		Electronics unit accessibility		
Plan the voltage supply	Operating voltage, power requirements	As shown in Techn. Data (→ p. 179, § 12.2)	Ensure adequate cable cross-sections and protection	<input type="checkbox"/>

3.2.2 **Determining the measuring and installation location**

Measuring precision is influenced, among other things, by flow behavior and the position of the measuring axis. Large cross-section variations, curved pipes, fittings, air flaps or inlets can cause profile deformations or turbulence with a negative effect on the measuring result.

Fig. 15 Measuring and installation location

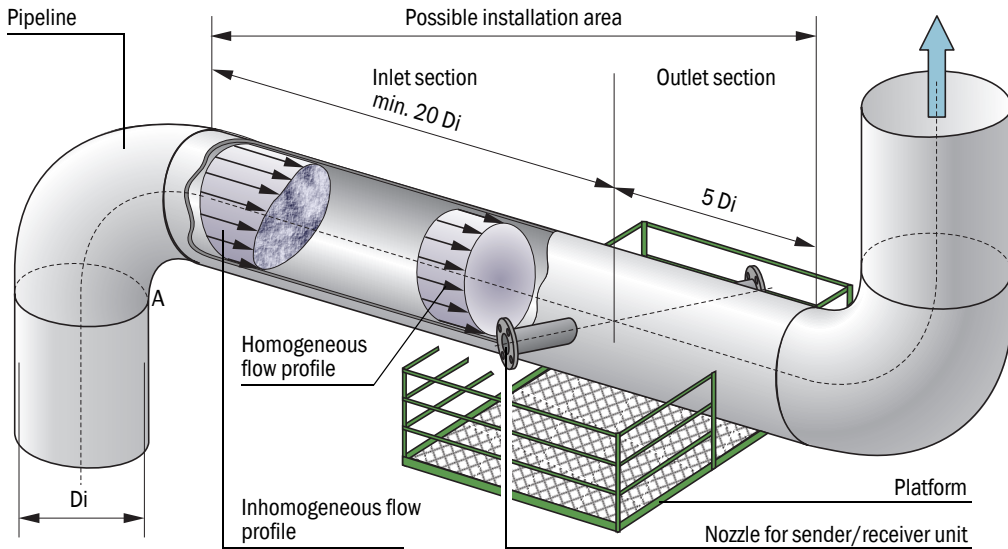

3.2.2.1 **General requirements**

Criteria		Requirements
Measuring location	Flow behavior	Position with essentially homogenous gas flow Balanced, uniform profiles are most likely to be expected for long inlet and outlet paths
	Pipeline design	Whenever possible, no deflections, cross-section variations, curves, feed and drain lines, flaps or fittings in the area of the inlet and outlet paths
	Inlet and outlet path lengths	The longer the inlet section (especially), the better the reproducibility of measuring results. Isometric conditions at measuring point are most important for determining the required upstream and downstream piping and should be checked carefully. <ul style="list-style-type: none"> ● Uncritical inlet conditions with a single 90° bend require a straight inlet pipeline > 20 x Di and outlet pipeline > 5x Di. ● More complex inlet disturbances require longer pipings up to 30 Di/10 Di. ● For too short inlet/outlet paths: Inlet path > outlet path
Installation location		Pipelines with vertical, horizontal or inclined direction Installation free of vibrations, acceleration < 1 g Largest possible distance to control valves or other noisy fixtures Adequate installation space (→ p. 54, Fig. 16)
Platform		Easy and safe access for installation and maintenance work of the sender/receiver units Platform secured by a railing to prevent possible accidents Clearance for assembling sender/receiver units (→ p. 54, §3.2.2.3)
Wall and insulation thickness		<ul style="list-style-type: none"> ● Maximum wall thickness 20 mm, maximum insulation thickness 100 mm. ● Larger wall and insulation thicknesses require customer-specific solutions (available on request only).

i ▶ On new systems: Comply with the specifications.
 ▶ On existing systems: Select the best possible location.



► *For ideal installation:* Request advice from the manufacturer.



CAUTION: Accident hazards

► Observe local safety regulations and occupational health and safety regulations in addition to these Operating Instructions.

3.2.2.2 **Additional requirements for a spool piece (option)**

Criteria	Requirements
Pipeline design	<ul style="list-style-type: none"> ● Select the measuring tube in the same rated width as the pipeline ● Deviations from inner diameter of the inlet pipe and spool piece < 1%. ● No welding beads and burrs on the insides of the spool piece
Assembly	Pipelines with horizontal or vertical direction <ul style="list-style-type: none"> ● Horizontal installation: Align the spool piece so that level created by the measuring paths is horizontal. ● Vertical installation: Only possible if the measuring system is used for dry, non-condensing gases. See information → p. 55, §3.2.3 a)
Gas flow	Free from any foreign material, dust and liquids. Otherwise, filters and traps shall be used.
Seals between meter body and pipeline	Must not protrude into the pipeline. Any protrusion into the flowing gas stream may change the flow profile and thus the measuring accuracy may be adversely affected.
Pressure sensor	The connection on the pressure inlet nozzle can be a bushing or a flange, depending on the size of the spool piece or customer requirements.
Clamping sets and seals	Bolts, nuts and flange seals used must be suitable for the operational conditions and comply with legal regulations and relevant standards.

3.2.2.3 Clearance next to the pipeline

Fig. 16 Space required during installation

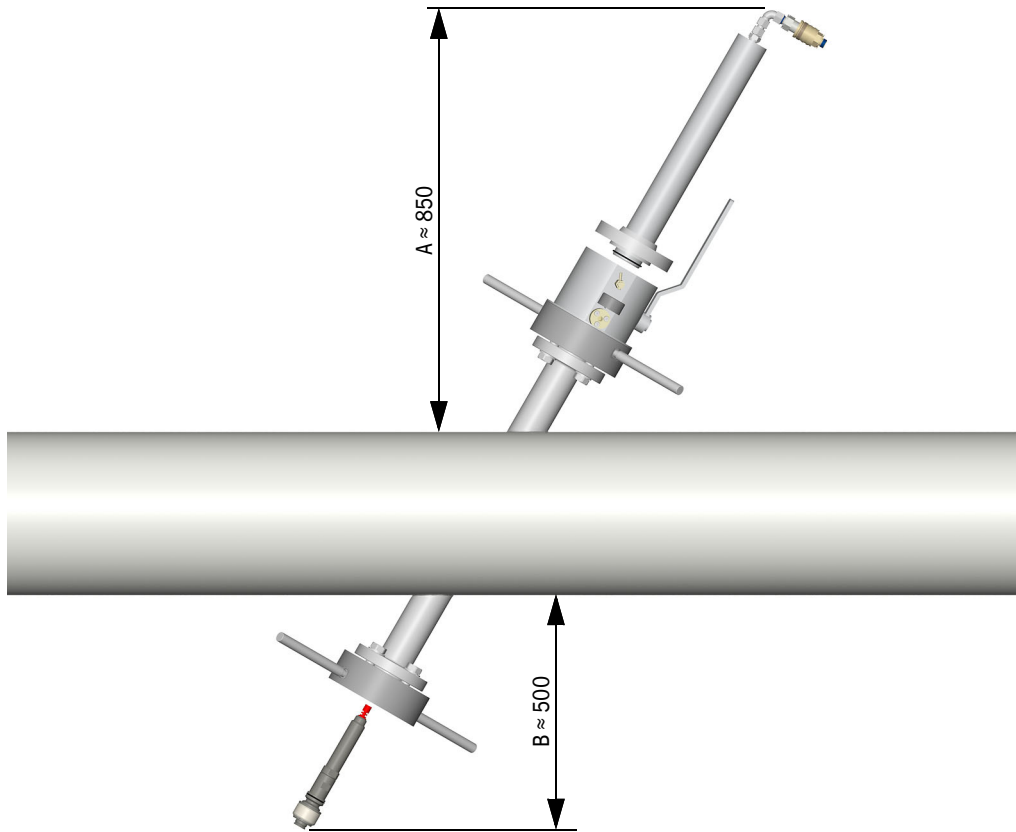

- A = Lateral clearance required on both sides of the pipeline for using the fitting tool
- B = Lateral clearance required on both sides of the pipeline for operation of FLOWSIC300 without using the fitting tool

3.2.3

Further notes for project planning

Applications with specific conditions or installation in vertical pipelines

a) Applications with wet gas

Condensate can accumulate in the nozzle pipes. Following solutions can help avoiding measuring problems (malfunctions caused by solid-borne noise, see Service Manual) or damage when removing the ultrasonic sensors (condensate escaping).

- ▶ Use a nozzle position which prevents accumulations of condensate in nozzle pipes.
- ▶ Use a closed continuous or periodical condensate drain with backflow to the pipeline. Technical solutions are available on request depending on operating conditions (pressure, temperature).

 ▶ Obtain approval from the plant operator before installing condensate drains.

- ▶ Isolate the nozzle pipe to reduce dew point underflow (only for low gas temperatures < 100 °C).

b) Short inlet and outlet paths (→ p. 52, Fig. 15)

- ▶ Use the best possible positioning for the measuring path (consult Endress+Hauser for support).

Installation location for separate pressure and temperature sensors (option)

- ▶ Install pressure tap and immersion sleeves for separate sensors as follows:

Component	Installation location
Pressure tap	<ul style="list-style-type: none"> - At measuring location - In the 10 - 2 o'clock area on the pipeline
Immersion sleeve for temperature measurement	<ul style="list-style-type: none"> - After the measuring location (in flow direction) - Distance to center of measuring path = 3D

 Example diagram for sensor integration in the system → p. 27, §2.3.4

3.3 Preparation work

3.3.1 Checking delivery

- ▶ Check delivery includes all ordered parts.
- ▶ Check delivered parts for damage. Especially:
 - Transducer surfaces of the ultrasonic sensors
 - Sealing surfaces on flanges
 - Inside of the spool piece (*when delivered*)
- ▶ Document any damage determined and report to the manufacturer.

3.3.2 Checking operating conditions



CAUTION: Risks from incorrect flowing conditions

- ▶ Ensure the conditions at the installation location and the specifications on type plates match (→ p. 188, Fig. 78, → p. 29, Fig. 5).

Otherwise the FLOWSIC300 does not run reliably and is possibly unsafe.

3.3.3 Tools required

The following tools are required for installation:

- Allen keys, 6 mm, 8 mm, 14 mm
- Torque wrench, measuring range 155 Nm
- Attachment for torque wrench 24 mm, 30 mm
- Wrenches, SW 11 mm, 24 mm, 27 mm, 30 mm

3.4

General safety information



CAUTION: General hazards during installation

- ▶ Observe the safety information in these Operating Instructions.
 - ▶ Observe legal regulations, standards and guidelines.
 - ▶ Observe local regulations, safety regulations and company-internal operating instructions.
 - ▶ Check whether special regulations are applicable for the respective plant.
 - ▶ Check whether particular local hazards exist. Take suitable protective measures when necessary.
 - ▶ Use suitable lifting equipment during transport and assembly. Observe maximum loads.
 - ▶ Ensure personal protective equipment is used.
- Otherwise health risks and material damage can occur.



WARNING: Hazards through electrical voltage

- ▶ *Before working on mains connections or live components:* Make sure the power supply to the device is switched off (disconnected from the mains and potential-free).
- ▶ *Before switching the mains supply on:* Ensure a safe state (e.g. fit shock protection, close enclosure).

3.5

Safety information on gas tightness



WARNING: Hazards through leaks

- ▶ During installation and maintenance, ensure gas tightness is secured and will remain secured.
 - ▶ Check condition of seals and sealing surfaces. Only fit intact, clean seals. Replace questionable seals. Only use replacement seals that match the individual specification (information → p. 14, § 1.4.1).
 - ▶ Only put the measuring system into operation when overall gas tightness is ensured.
- Otherwise possible risk of explosions and health hazards.

FLOWSIC300

4 Installing the nozzles

Safety information

Marking and assembling on the pipeline

Fitting the spool piece (alternative, option)

4.1 Assembly information

4.1.1 Safety information for assembly work

**CAUTION: General accident hazards**

Some components are heavy. Incorrect and careless handling of these components creates accident hazards.

- ▶ Do not work under suspended loads (suspended heavy components).
- ▶ Secure components and tools against dropping and unintentional movement.
- ▶ Wear safe working clothes (safety shoes, gloves).
- ▶ Warn other persons as necessary.

**WARNING: Hazards through gas**

- ▶ Observe the safety information in §1.2.1 (→ p. 10).

**WARNING: Hazard through unstable assembly of the nozzle**

The maximum load torque when fitting the device with the fitting tool can be up to 300 Nm.

- ▶ Consider the maximum load torque during mechanical installation and when welding the welding seams.
- ▶ If required, support the nozzles additionally on the pipeline in a suitable manner.
- ▶ Carry out welding work correctly (→ p. 10, §1.2.1).



All dimensions are in mm (if not specified otherwise).

4.1.2

Position of nozzles on the pipeline

Position to pipe center

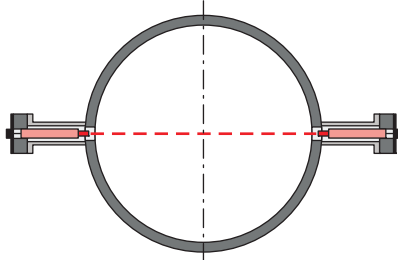
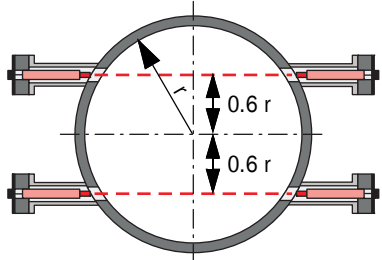
1-path configuration	2-path configuration
<p>▶ Weld the nozzles on so that the measuring path goes through the middle of the pipeline.</p>	<p>▶ Weld 2 nozzles parallel to each other on each side of the pipeline. ▶ Distance to pipe center = each 60% of the pipe inner diameter.</p>
	

Fitting angle

- ▶ Fit the nozzles at an angle of $(\alpha) = 60^\circ$ to the pipeline (when not specified otherwise in the individual information).
- ▶ Fit the nozzles horizontal whenever possible.



- No liquid (e.g. condensate) can collect in the nozzles when these are horizontal.
- Procedure description → p. 66, § 4.2.3

Fig. 17

Nozzle fitting angle (α)

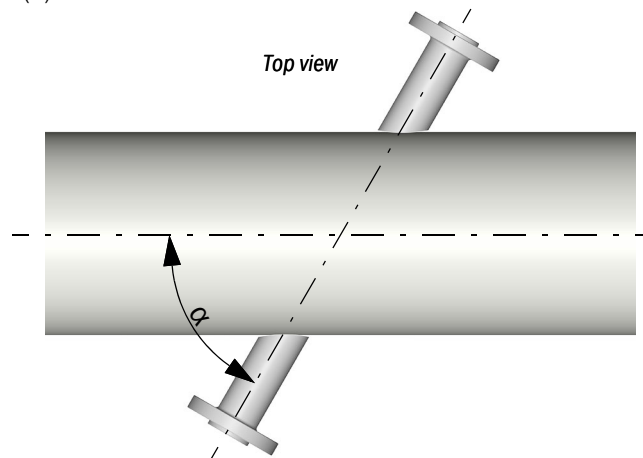

4.2 Nozzle assembly

Not applicable when a spool piece is included in the scope of delivery (description → p. 29, §2.5.1, fitting → p. 72, §4.3)

4.2.1 Assembly information

Pipeline dimensions

The exact actual inner diameter of the pipeline must be known at the installation location. A predefined specification from a standard is not sufficient.

- ▶ When necessary, measure the outer diameter and wall thickness of the pipeline.

Installation dimensions

The nozzle installation dimensions are required for configuring the measuring system (during initial start-up).

- ▶ Document all geometric dimensions determined during installation (see instructions).

Precision required during assembly

Inexact nozzle assembly can have a negative influence on measuring precision.

- ▶ Fit the nozzles at the marked positions with a precision of ± 1 mm.



When a spool piece (→ p. 29, §2.5.1) with the option “3D measurement” is used, the nozzle position is determined with a precision of ± 0.1 mm.

4.2.2

Marking the nozzle positions

Step 1: Adapt the foil strip on the nozzle installation tool to the pipeline

- 1) Wind the foil strip at the measuring point with an overlap of 20-30 cm around the pipeline.
 - Cut off the protruding rest.
 - Ensure exact right-angled alignment
 - Secure the foil strip on the pipeline (e.g. with adhesive strips)

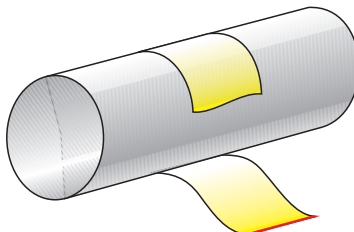

- 2) Mark the foil strip when the overlap starts.

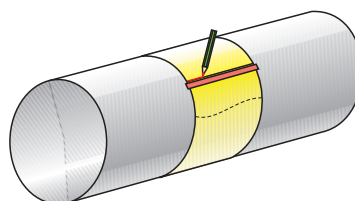

- 3) Take the foil strip off and lay it out on a flat surface.

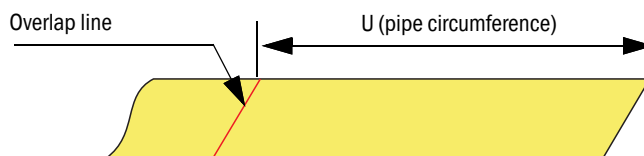

For 1-path measurement: Wrap the strip up to where the overlap starts and then fold it so that the part corresponding to the pipe circumference is halved.

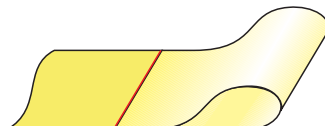

- The foil strip is delivered with the installation tool.
- Foil length = 5 m
- Foil width = 0.5 m

Step 2: Mark the nozzle positions on the foil strips

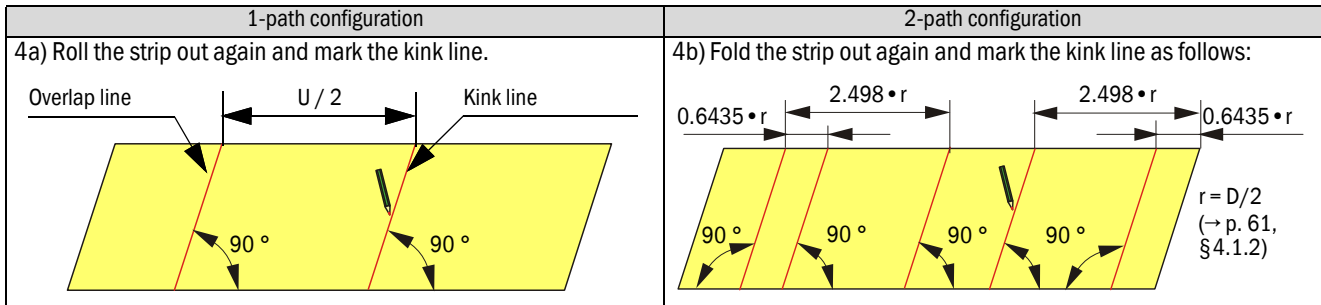

5) Draw guide lines (1) for the nozzle positions in a distance as listed in the Table, mark the crossing points (2) and draw marking points (3) in distance 60 mm (x) from the crossing points.

The following Tables are valid for nominal pipe widths according to ANSI B36.10. If pipeline diameters deviate, the associated nozzle clearance can be calculated using the Geometry Calculation Sheet “Calc transducer distance”.

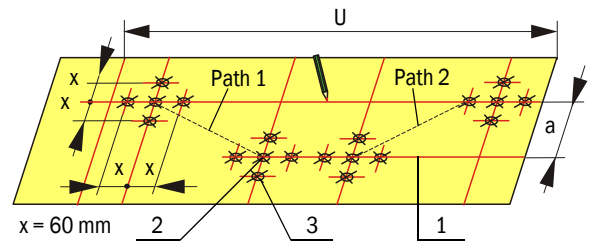
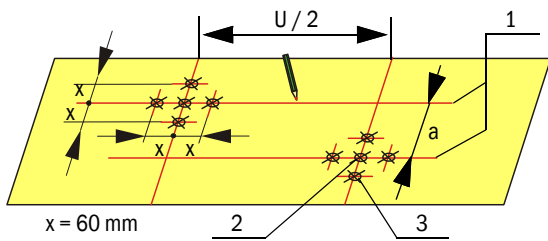

Nominal size	Outer diameter		Nozzle distance a	
	inch	mm	mm	inch
4		114.3	66	2.6
5		141.3	82	3.2
6		168.3	97	3.8
8		219.1	126	5.0
10		273	158	6.2
12		323.8	187	7.4
14		355.6	205	8.1
16		406.4	235	9.2
18		457.2	264	10.4
20		508	293	11.5
22		558.8	323	12.7
24		609.6	352	13.9
26		660.4	381	15.0
28		711.2	411	16.2
30		762	440	17.3
32		812.8	469	18.5
34		863.6	499	19.6
36		914.4	528	20.8
42		1066.8	616	24.2
48		1219.2	704	27.7
52		1321	763	30.0
56		1422	821	32.3

Nominal size	Outer diameter		Nozzle distance a	
	inch	mm	mm	inch
4		114.3	53	2.1
5		141.3	65	2.6
6		168.3	78	3.1
8		219.1	101	4.0
10		273	126	5.0
12		323.8	150	5.9
14		355.6	164	6.5
16		406.4	188	7.4
18		457.2	211	8.3
20		508	235	9.2
22		558.8	258	10.2
24		609.6	282	11.1
26		660.4	305	12.0
28		711.2	328	12.9
30		762	352	13.9
32		812.8	375	14.8
34		863.6	399	15.7
36		914.4	422	16.6
42		1066.8	493	19.4
48		1219.2	563	22.2
52		1321	610	24.0
56		1422	657	25.9

6a) Measure and note values a and U/2 (required for calculating path angle and path length).

6a) Measure and note values a and U (required for calculating path angle and path length).

Step 3: Transfer the nozzle positions onto the pipeline

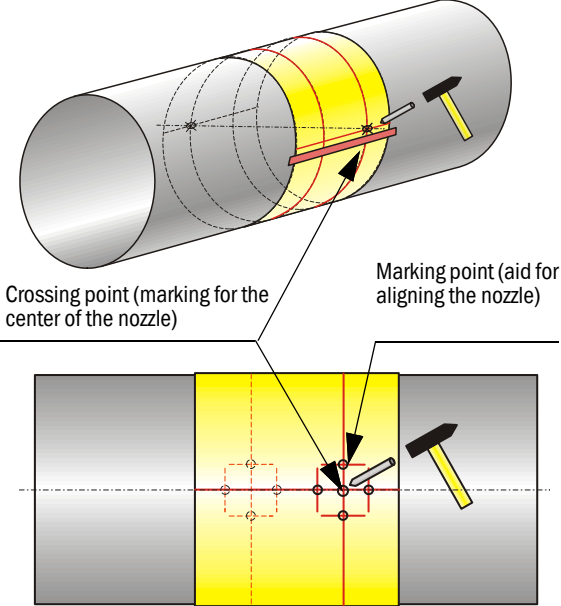
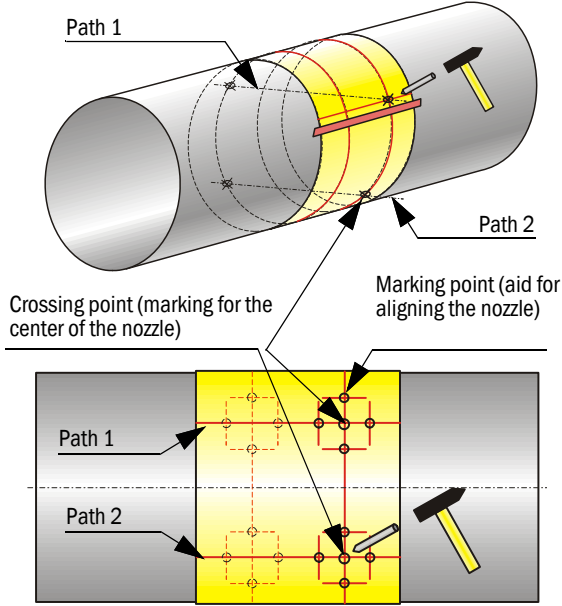
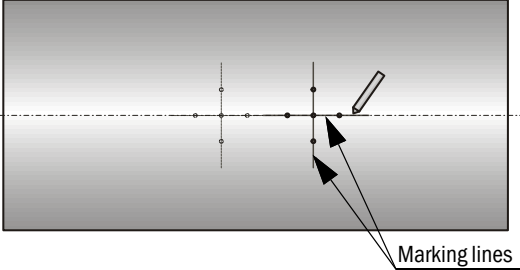
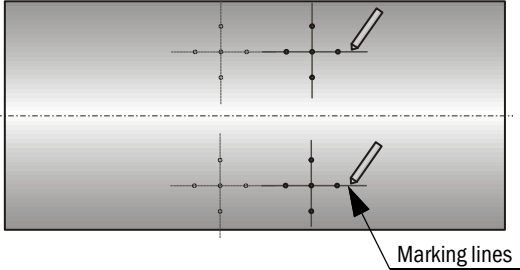
1-path configuration	2-path configuration
<p>7) Wind the foil strip around the pipeline again at the measuring location. Fix the foil strip so that the crossing points are horizontally opposite each other.</p> <p>8) Use a metal center punch to mark the nozzle positions with crossing and marking positions.</p> 	
<p>9) Take the foil strip off again. Join the additional markings with lines.</p> 	

4.2.3 **Welding the nozzle on**

Installation tool for nozzles

- ▶ Use the delivered installation tool for assembling the nozzles.

Fig. 18 Installation tool for the nozzles (schematic)

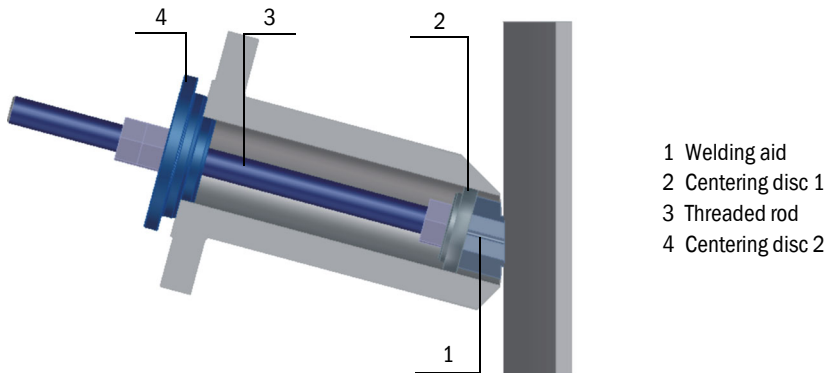

Step 1: Ensure safe conditions

 **WARNING: Hazards due to combustible gases or high pressure**
Before commencing installation work:

- ▶ Ensure the pipeline is free from pressure and free from combustible substances. Purge the pipeline when necessary.
- ▶ Only carry out welding work when it is ensured that no risk of explosions can arise.
- ▶ Observe the safety information in §1.2.1 (→ p. 10) and §3.4 (→ p. 57).

 **WARNING: Hazards during welding work**

- ▶ Only allow skilled persons qualified for work on pressure lines to carry out the welding work.
- ▶ Observe laws, standards and guidelines.
- ▶ Observe local operating regulations. Comply with regulations of the plant operator.

Step 2: Attach a welding aid

- 1 Screw welding aid (1) to the tip of threaded rod (3).
- 2 Position the tip of the threaded rod onto the crossing point and weld the welding aid to the pipeline.

Fig. 19

Positioning the welding aid

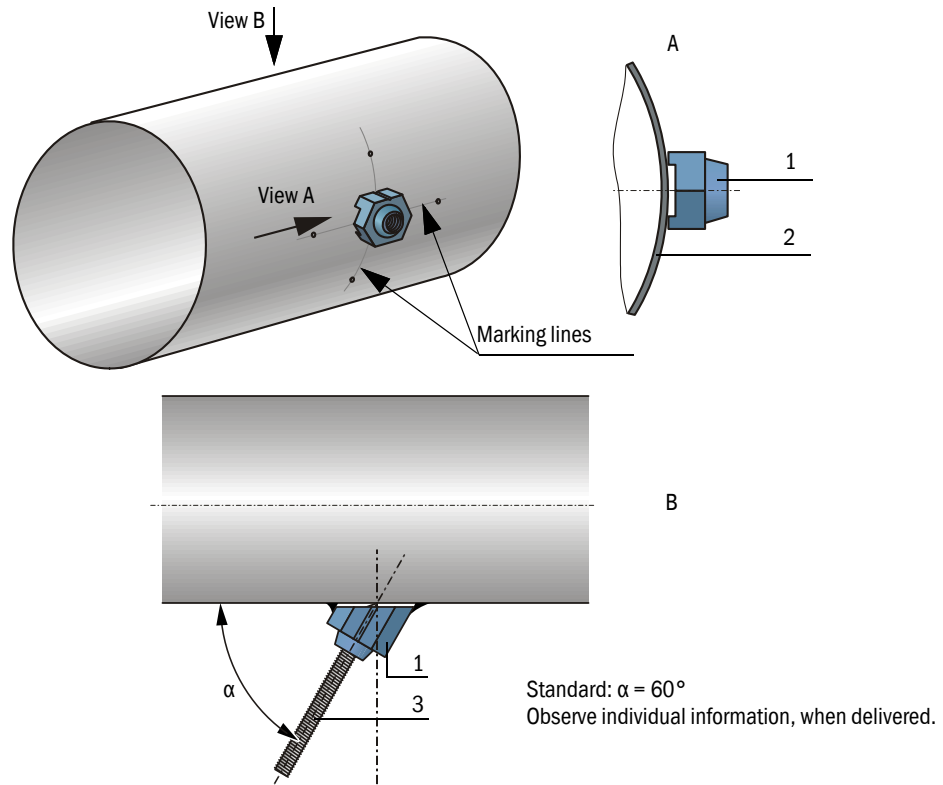

NOTICE:

- The deviation from the marking lines should not exceed 0.5 mm after welding.
- ▶ Check the welding aid for correct positioning after welding.
- ▶ *If the deviation is larger than the nominal position:* Loosen the welding aid and position again.

Step 3: Fasten the nozzle

- 1 Push small centering disc (4) into the cone of welding aid (1) and secure with nut (5).

Fig. 20

Fitting the nozzle

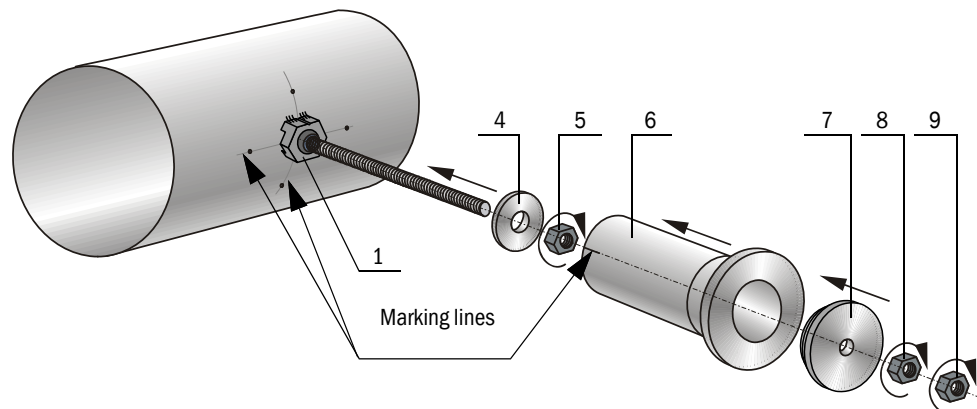

- 2 Slide nozzle (6) over threaded rod and centering plate.
- 3 Position large centering disc (7) on the nozzle.

- 4 Screw counternuts (8), (9) onto the threaded rod and secure the nozzle on the pipeline. Make sure the gap between the pipeline and the nozzle is sufficient to ensure the formation of a correct welding root. An uncoated wire with approx. 2 mm diameter, for example, can serve as spacer.
- 5 Align the nozzle so that the marking lines on the nozzle and pipe wall (→ Fig. 20) are flush and tighten the screws until the nozzle is pressed against the wire and pipeline surface. Make sure the nozzle remains aligned correctly.
- 6 Attach the nozzle circumferential to the pipe wall.
- 7 Remove the wire.
- 8 Remove threaded rod with nuts and centering by turning the counternut (8) against fastening direction.

Step 4: Finish the welding seam

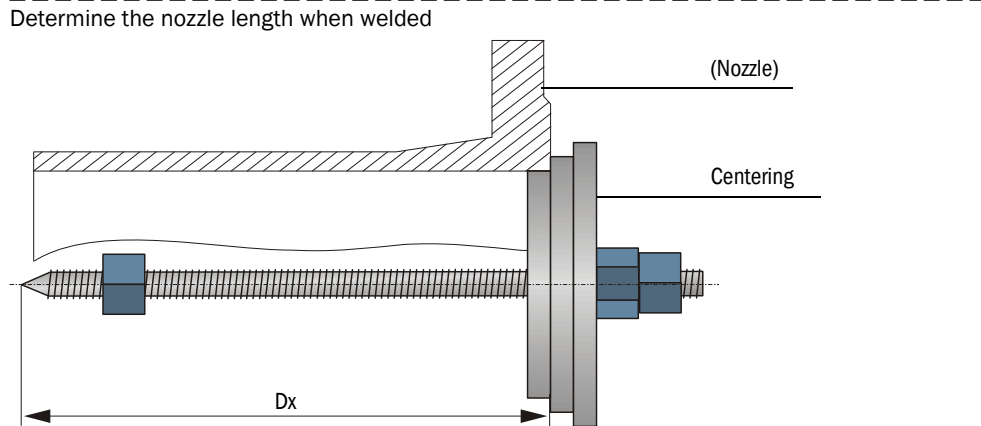

- 1 Apply the welding heat as evenly as possible and keep it low to minimize warpage. Observe the maximum intermediate layer temperature according to the weld instructions.
- 2 Determine the distance between pipe outer wall and centering (D1; see also → p. 71, Fig. 25).

Fig. 21



Step 5: Weld the second nozzle on

- ▶ Weld the second nozzle on the opposite side of the pipeline in the same manner.
- ▶ Determine the distance between pipeline outer wall and centering again (D2).

	<p>WARNING: Risk of explosion/health hazard</p> <p>A faulty welding seam can allow gas to escape from the pipeline. This can immediately lead to a dangerous situation.</p>
	<ul style="list-style-type: none"> ▶ Ensure welding seams are gas-tight. ▶ Check strength and durable tightness of the welding seams.

4.2.4 **Determining the path length and installation angle**

Purpose

The path length (length of ultrasonic path) and the path angle must be determined as exact as possible to obtain optimum measuring precision. These values must be entered during initial start-up (→ p. 134, §8.5).

Variant 1 (with “open” pipeline)

- 1 Determine the distance of the sealing surfaces of both nozzles R and angles β_1, β_2 as exact as possible (→ Fig. 22).

Fig. 22

Installation parameters

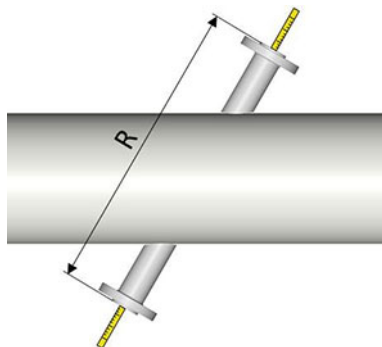

- L = Path length
- R = Distance of nozzle sealing surfaces
- NL = Nominal length of probe (standard = 206 mm)
- S = Seal thickness (standard = 4 mm)

Path angle α = 60° (nominal value)

- 2 Calculate the path length L

Fig. 23

Formula for the calculation of path length L

$$L = R + 2 \times S - 2 \times NL$$

Variant 2 (alternative, when R cannot be determined exactly)

- 1 Determine dimensions a, D1, D2, β_1 , β_2 as exact as possible (→ Fig. 25).
- 2 Use the FLOWSIC300 geometry tool provided to calculate path angle α and path length L (formulas → p. 71, Fig. 26) or calculate manually. Note calculation results and make these available for initial start-up.



- The geometry tool is a calculation Table for Microsoft Excel (→ Fig. 24).
- Geometric dimension precision influences the overall measurement uncertainty.

Fig. 24

Geometry tool

Geometry Calculator - FLOWSIC 300
 17500901
 Calculation tool for Path length, angle, diameter.

Sprache: Deutsch English Русский

Meter type: 1Path

Input
 Assembling parts dimension after commissioning

Transducer distance	a	0.1265	m	
Circumference	U	0.6882	m	
Wall thickness	w	0.0082	m	
Gasket thickness	s	0.004	m	
Length nozzle 1	D1	0.1937	m	includes 3.73 mm welding gap
Length nozzle 2	D2	0.1937	m	includes 3.73 mm welding gap
Transducer nominal length	NL	0.206	m	
Nozzle angle 1	β_1	60	°	enter only for Ex and Ex.Fe
Nozzle angle 2	β_2	60	°	enter only for Ex and Ex.Fe

Results
 Parameter for MEPA program configuration

Path length	L	0.2364	m
Path angle	α	60	°
Diameter inside	Di	0.2027	m
Cross Section Area	Area	0.0323	m ²

Fig. 25 Determining the path length and installation angle

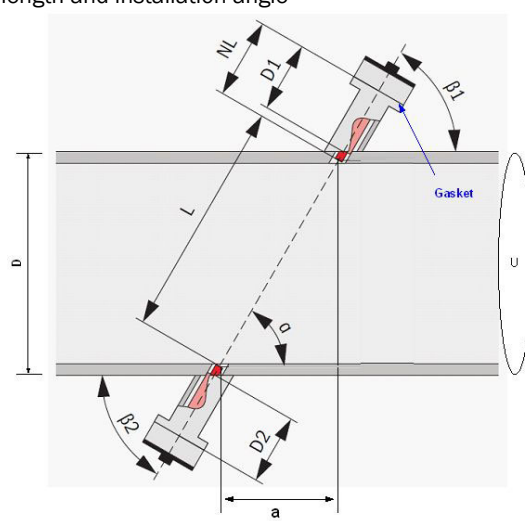

- L = Path length
 - NL = Nominal length of probe (standard = 206 mm)
 - D1, D2 = Nozzle lengths when welded (→ p. 68, Fig. 21)
 - α = Path angle
 - β_1, β_2 = Assembly angles of nozzles [1]
 - U = Pipeline circumference at installation location
 - S = Seal thickness = 4 mm
 - f = 1,0 [2]
- [1] Standard: 60°
 [2] Value valid for 1-path measurement. For 2-path measurement (option): f = 0.8.

Fig. 26 Formulas for geometric parameters

$$b = a - (NL - D1 - S) \cdot \cos \beta_1 - (NL - D2 - S) \cdot \cos \beta_2$$

$$k = \frac{U}{\pi} \cdot f - (NL - D1 - S) \cdot \sin \beta_1 - (NL - D2 - S) \cdot \sin \beta_2$$

$$L = \sqrt{b^2 + k^2}$$

$$\alpha = \operatorname{atan}\left(\frac{k}{b}\right)$$

4.3 Installing the spool piece (optional)



This information is only valid when the scope of delivery includes a spool piece (→ p. 29, §2.5.1).

4.3.1 Safety information for the spool piece

4.3.1.1 Transport safely

- ▶ Ensure the spool piece is always fixed and secured.
- ▶ Handle with care - avoid damage.
- ▶ Lift correctly (→ Fig. 27).

Fig. 27

Lifting requirements

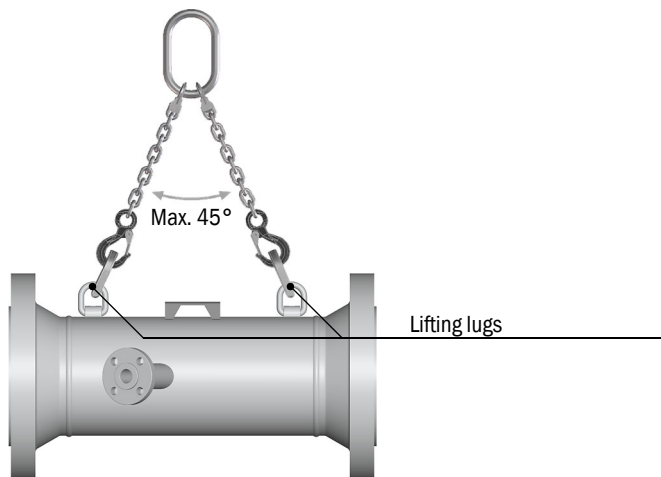

CAUTION: Hazard through improper lifting

Improper lifting leads to accident and injury risks, and the spool piece could be damaged.

- ▶ Only use the planned lifting lugs as lifting points.
- ▶ Consider the weight and size of the spool piece.
- ▶ Only use lifting equipment and load attachments (e.g. lifting belts) suitable for the spool piece weight. Compare the type plates of the lifting equipment and spool piece.
- ▶ Do not work under suspended loads.
- ▶ Also fasten any devices mounted to the lifting equipment and brace these during transport.

4.3.1.2

Store properly

- ▶ Comply with permissible storage conditions (→ p. 179, §12.2).
- ▶ Protect sealing surfaces and the inside of the spool piece against corrosion during storage (e.g. with Anticorit-Spray).



Spool pieces made of stainless steel may not need corrosion protection.

4.3.2 **Inserting the spool piece in the pipeline**

- ▶ Insert the spool piece in the pipeline at the measuring location (→ p. 52, §3.2.2).
- ▶ Fit the spool piece so that the following conditions are met:
 - The spool piece arrow markings point in pipeline flow direction.
 - The side nozzles are horizontal.
 - The spool piece is centered as exactly as possible in the pipeline.
- ▶ Fit flange seals carefully.
 - Check condition of sealing surfaces.
 - Only use seals in perfect condition.
- ▶ Tighten flange screws correctly:
 - Crosswise, alternately and in small steps
 - Finally tighten all screws with the tightening torque specified.



NOTICE:

- ▶ Fit the ultrasonic sensors before pipeline start-up (→ p. 75, §5 or → p. 83, §6).

4.3.3 **Determining the pipeline diameter**

Pipeline inner diameter D_i is used for configuring the geometric data. It can be calculated as follows:

$$D_i = \frac{U}{\pi} - 2 \cdot W$$

U = Pipeline circumference at installation location
 W = Wall thickness

Recommendations:

- ▶ Determine the wall thickness by measuring (e.g. with ultrasonic measurement technology).
- ▶ Measure the wall thickness at four different points and use the mean value.



The actual wall thickness can vary by up to 13% of the wall thickness specified in corresponding standard.

FLAWSIC300

5 Fitting the sender/receiver units in idle operation (cold tap)

Safety information
Fitting the sender/receiver units

5.1 **Important Information**

 **DANGER: Accident and health risks**
The information concerning the installation of the sender/receiver units and the ultrasonic sensors in this Chapter applies exclusively for work on a pipeline not in operation, does not contain hazardous or explosive gas or gas dangerous to health and is not under pressure.

- ▶ Before starting work, the planned measures must be explicitly approved by the plant operator and the following must be ensured by suitable measures for the complete duration of the work:
 - There is atmospheric pressure in the pipeline.
 - The pipeline does not contain gases which are dangerous, explosive or dangerous to health.
 - There is no risk of explosion in the vicinity of the pipeline.
 - The work will be monitored by a safety representative of the plant operator.
- ▶ The plant operator is responsible for ensuring and checking the safe state of the pipeline without dangerous gas.

 Fitting the sender/receiver units with hot tapping → p. 83, §6

5.2 **Fitting the sender/receiver units in idle operation /with non-pressurized line**

- ▶ Carry out this procedure once for each nozzle.

5.2.1 **Drilling a hole in the pipeline**

- ▶ Drill a hole in the pipeline in the center of the nozzle position.
 - Fasten a suitable drilling tool on the nozzle.
 - Hole diameter: $D_{min} = 30\text{ mm}$, $D_{max} = 35\text{ mm}$

 **WARNING: Risk of leakage due to contamination**
During the drilling process, drilling chips fall into the attachments (nozzle, transmitter/receiver unit, ball valve, etc.).

- ▶ After drilling, clean all attachments in a suitable manner.
Drilling chips and other contamination must be completely removed before installing the sensors. Endress+Hauser does not assume any warranty for the consequences of contamination of pipelines or attachments.

Fig. 28 Holes for the ultrasonic path (example: 1-path measurement)

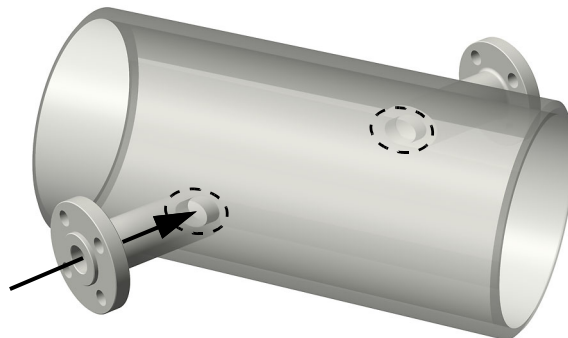

5.2.2 **Fitting the sender/receiver unit**

Assembly material

The assembly material for installing the sender/receiver unit includes:

- 4 screws, M20 x 60, material stainless steel
- 8 washers, 3/4", material steel, coated
- 1 serrated seal, material stainless steel/graphite
- Screw paste

Use the screw paste provided to prevent the fastening screws from “blocking”.

Fig. 29

Assembly material

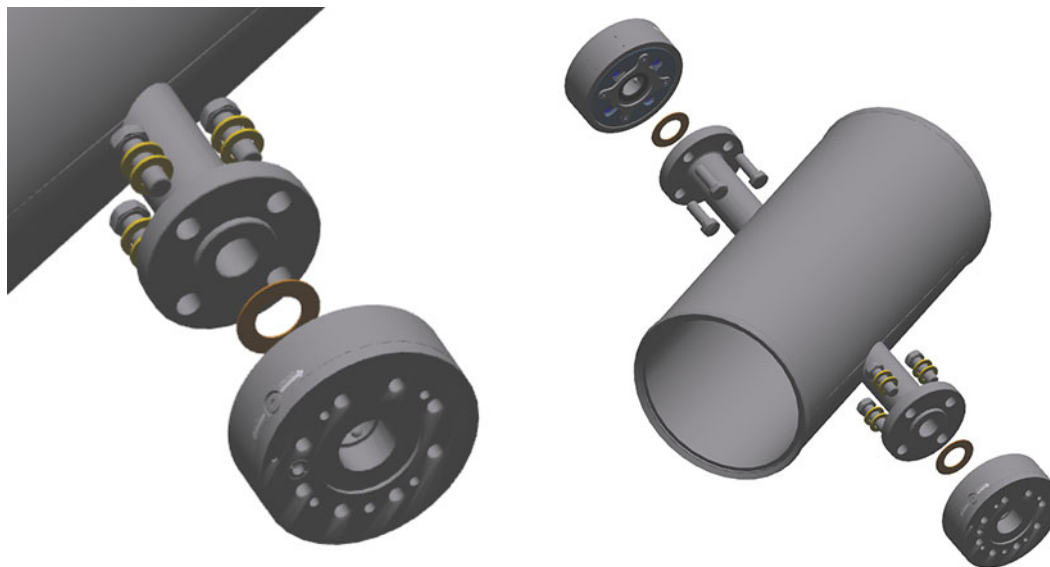

NOTICE:

Observe the following when fitting the enclosed flat seal:

The seal is positioned correctly using a specially adapted centering ring which is pre-installed at the factory on the process connection of the S/R unit (→ Fig. 30).

- ▶ First remove the centering ring before fitting the seal.
Loosen the fastening screws on the centering ring and remove the centering ring. Then place the seal on the process connection of the S/R unit and align it centrally.
- ▶ Re-install the centering ring and make sure the central position of the seal does not change.

Fig. 30

Process connection of the S/R unit with centering ring and installed flat seal

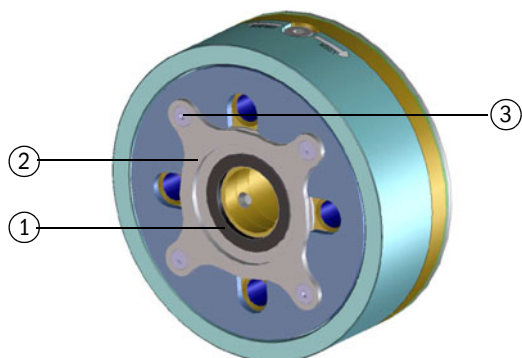

- 1 Flat seal in correctly installed position under the centering ring
- 2 Centering ring for flat seal
- 3 Fastening screws for centering ring

- Fitting the sender/receiver unit on the nozzle:
- The safety pin on the sender/receiver unit (marked red) must be aligned upwards to enable convenient working with the fitting tool.
 - Check/clean sealing surfaces
 - Flat seal
 - 4 M20 x 55 screws
 - Tightening torque: 155 Nm (use a torque wrench)

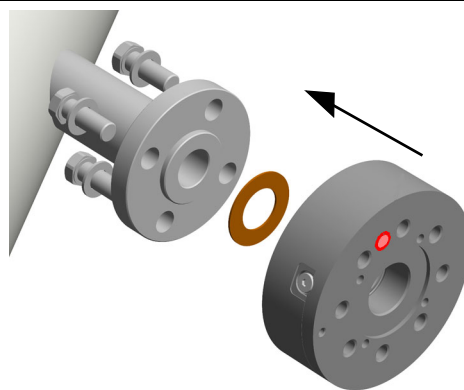

5.2.3

Installing the ultrasonic sensor

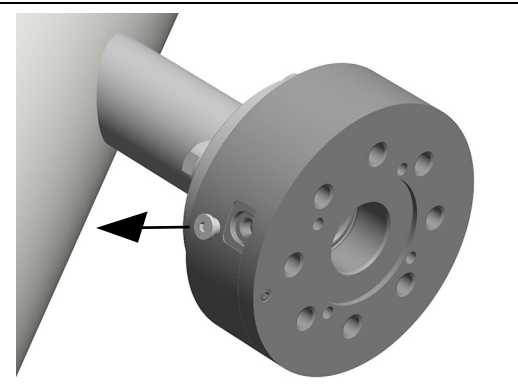
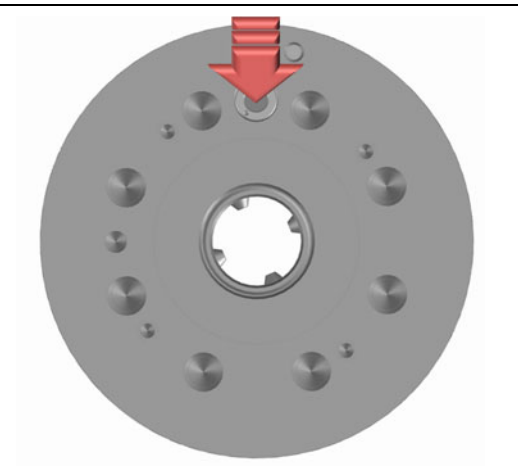
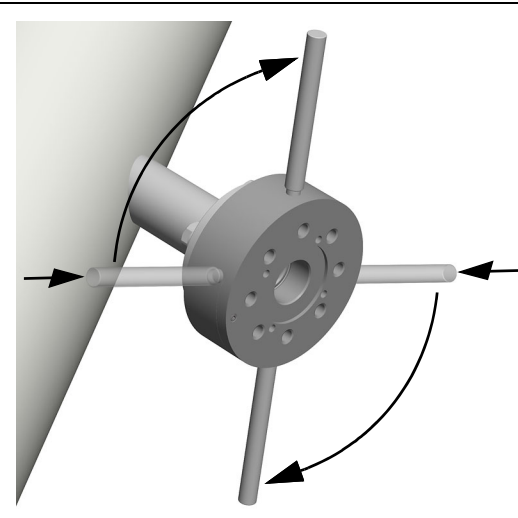
<p>1 Remove the screw plugs on the locking ring of the sender/receiver unit.</p> <p>2 Screw the handles in the locking ring</p>	
<p>3 Loosen the release lock by pressing the safety pin down with a suitable tool</p>	
<p>4 Unlock the sender/receiver unit:</p> <ul style="list-style-type: none"> - Grip both handles. - Turn the locking ring towards marking "UNLOCK" to the stop (75°). 	
<p>5 Prepare the sender/receiver unit and ultrasonic sensor:</p> <ul style="list-style-type: none"> ▶ Check/clean sealing surfaces ▶ Check the sealing ring (O-ring) of the ultrasonic sensor and clean/replace when necessary. 	

- 6 Let the ultrasonic sensor slide into the sender/receiver unit (to the stop).
For better handling, the delivered extraction tool (T-handle) can be screwed into the ultrasonic probe.

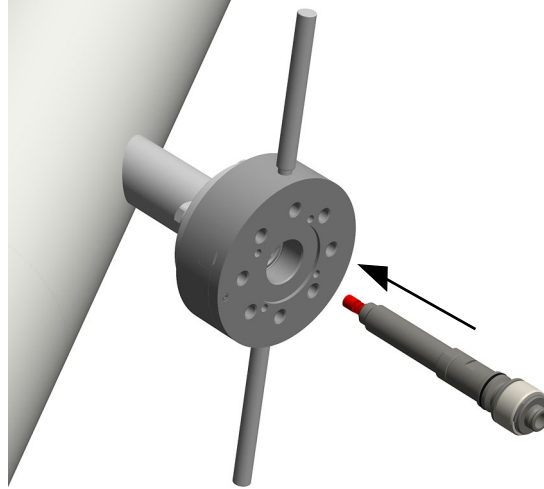

- 7 Lock the sender/receiver unit:
- Turn the locking ring handles towards marking "LOCK" to the stop.
 - Unscrew the handles.

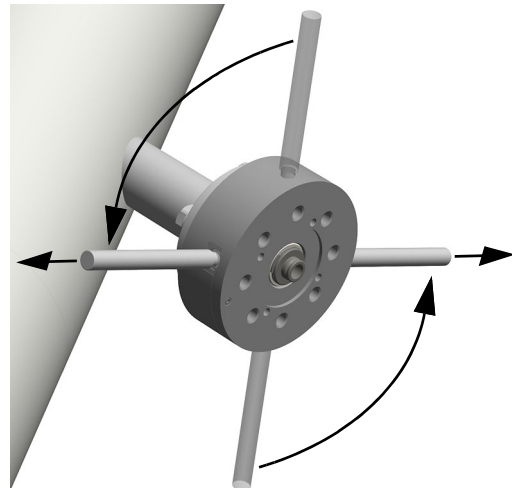

- 8 Refit the screw plugs.
- 9 Pull the probe cable out of the ultrasonic sensor (remove the plastic screw beforehand when necessary).

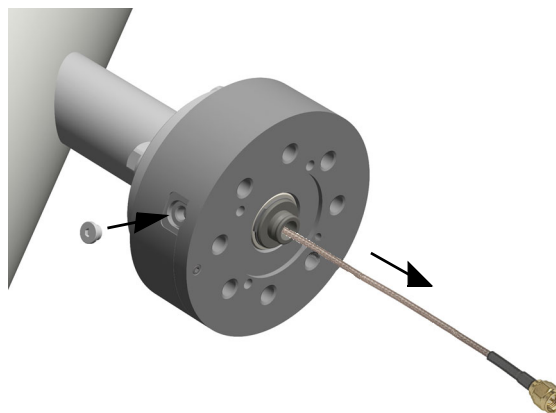

- 10 Connect the probe cable on the inside of the enclosure cover.
- 11 Check the enclosure cover seal for damage.
- 12 Fit the enclosure cover with the 4 screws.

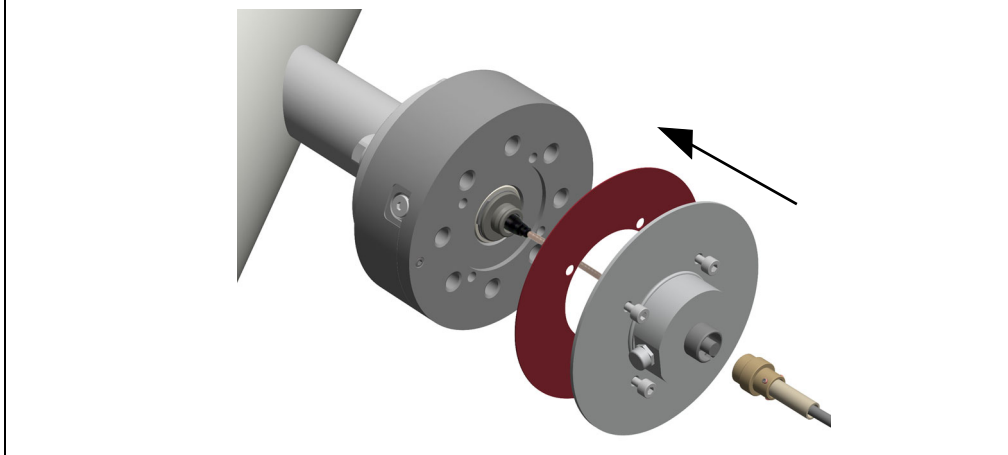

5.3

Leak tightness check after installation



► *Recommendation:* Carry out a leak tightness check after fitting the sender/receiver units according to valid regulations and standards.

- 1 Fill the pipeline with gas and create the test pressure.
- 2 Check the installation for leak tightness.



WARNING:

Only remove the ultrasonic sensors according to the instructions in the "Service Manual" for the FLOWSIC300.

FLAWSIC300

6 Fitting the sender/receiver units in running operation (hot tap)

Safety information

Handling

Fitting the sender/receiver units

6.1 Safety information for the fitting tool



- Fitting tool description → p. 30, §2.5.2
- Fitting the sender/receiver units without fitting tool → p. 75, §5

6.1.1 Work safety

- ▶ Only use the fitting tool for the described purposes and not for other purposes (e.g. not as lifting equipment)
- ▶ Do not overload the equipment (observe operation displays).
- ▶ Wear suitable protective clothing (gloves, safety shoes).
- ▶ Do not work under suspended loads.
- ▶ Protect equipment against intense heat (over 65 °C).
- ▶ Do not use equipment or tools that are damaged or in a questionable condition.
- ▶ Before each change: Check the function of the pressure gauge on the ball valve.

6.1.2 Safety of hydraulic equipment

- ▶ Observe the hydraulic pump Operating Instructions.
- ▶ Only work on a level, safe base.
- ▶ Check hydraulic couplings before use, clean when necessary.
- ▶ Do not bend hose lines and protect against damage. Avoid friction on edges and crimping.
- ▶ Before pumping, ensure mechanical and hydraulic connections are secure.
- ▶ Do not extend the pump lever of the hydraulic pump (e.g. with auxiliary means).
- ▶ Clean and store the equipment safely after use.

6.1.3 Proper installation



WARNING: Hazards through improper installation work
See → p. 60, §4.1

6.1.4 Accident risk



DANGER: Danger to life through careless handling

If a sender/receiver unit is unlocked without the fitting tool fitted, the sender/receiver unit can shoot out driven by the pressure in the gas line.

The locking mechanism is blocked as long as the fitting tool is not mounted completely to prevent faulty operation.

- ▶ Unlock a sender/receiver unit only when the fitting tool is mounted and ready.

Otherwise there is an immediate danger to life and the risk of severe injuries for persons in the flight path of the fitting tool shot out.

Note: This also applies when the cover is fitted on the sender/receiver unit. A sender/receiver unit shot out can smash through the cover.

- ▶ *Safety recommendation:* Always remove the handles from the locking ring of the sender/receiver unit after locking.



The handles on the locking ring of the sender/receiver unit can only be removed when locked.

6.2 **Using the fitting tool**

	<p>WARNING: Explosion hazard</p> <p>The fitting tool is not approved for operation in explosive atmospheres. When used on the pipeline, risk of explosion must be excluded signaled in time by suitable or a possible ignition hazard signaled in time by suitable means, e.g. monitoring with gas detector.</p>
---	---

6.2.1 **Assembling the fitting tool**

- 1 Check hydraulic couplings before use, clean when necessary.
- 2 Connect the hydraulic cylinder and hydraulic pump with the hydraulic hose (plug-in connections).

	<p>The hydraulic pump and hydraulic hose are filled with hydraulic oil and ready for operation when delivered.</p>
---	--

6.2.2 **Moving the hydraulic**

	<p>► Observe the hydraulic pump Operating Instructions.</p>
---	---

Extending the hydraulic piston:

- 1 Close the pressure valve of the hydraulic pump (turn handwheel clockwise to stop).
 - 2 Activate the pump lever of the hydraulic pump.
- Watch the pressure gauge on the hydraulic pump.

	<p>The movement range of the hydraulic piston is limited by the oil level in the hydraulic pump.</p>
---	--

Retracting the hydraulic piston:

- Slowly open the pressure valve of the hydraulic pump.
- *When removing an ultrasonic sensor during running pipeline operation:* Only open the pressure valve slightly and listen to the sound of the retracting hydraulic piston. First open the pressure valve fully when the hydraulic piston is in the end position.
- *If the hydraulic cylinder is not fitted:* Open the pressure valve and push the hydraulic piston manually into the hydraulic cylinder (use the wooden rod provided as aid).

6.2.3

Setting the coupling

- Set the coupling appropriately before using the fitting tool:

1 Extend the coupling:

- Close the pressure valve of the hydraulic pump.
- Pump until the coupling appears.

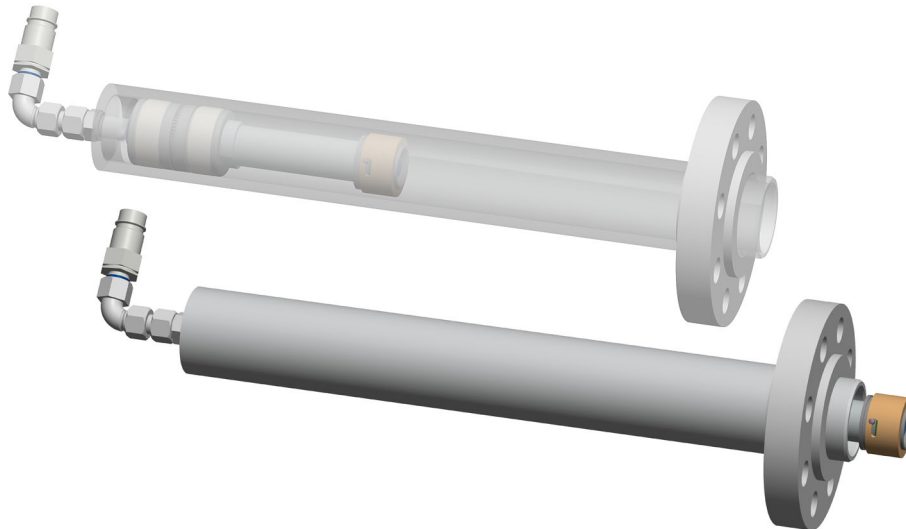
**2** Set the coupling as required:

To fit: Unlocked

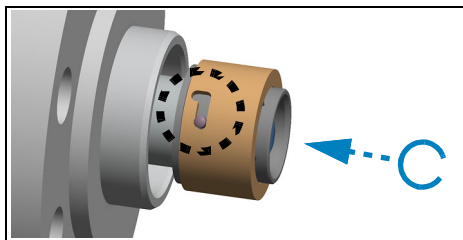

To remove: Engaged

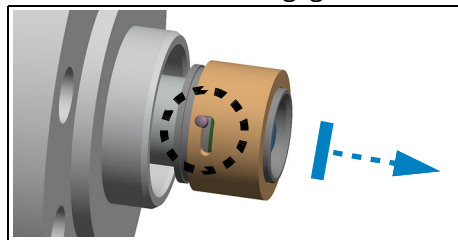

3 Checking the movement range of the hydraulic cylinder:

- Carefully push out the hydraulic cylinder by pumping with the hydraulic pump.
- Check whether the minimum dimension $L = 120$ mm is reached.
- Do not push out the hydraulic cylinder more than $L = 130$ mm!

If the hydraulic cylinder cannot be pushed out at least $L = 120$ mm, check the oil level in the hydraulic pump:

- To do this, open the pressure valve and push the hydraulic piston manually into the hydraulic cylinder (use the wooden rod provided as aid).
- Replenish oil as required. See the Operating Instructions provided with the hydraulic pump for the required oil level.

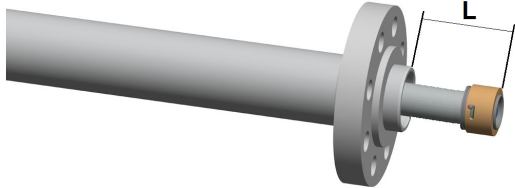

4 Press the hydraulic piston back into the hydraulic cylinder:

- Open the pressure valve of the hydraulic pump.
- Press the hydraulic cylinder manually into the hydraulic cylinder.

6.2.4 **Using the ball valve**

- Observe marking on the face side of the spindle of the ball valve:

Fig. 31 Ball valve fitting tool (figure without operating lever mounted)

- 1 Angle of rotation with limiter
- 2 Safety pin for fixing the rotation angle

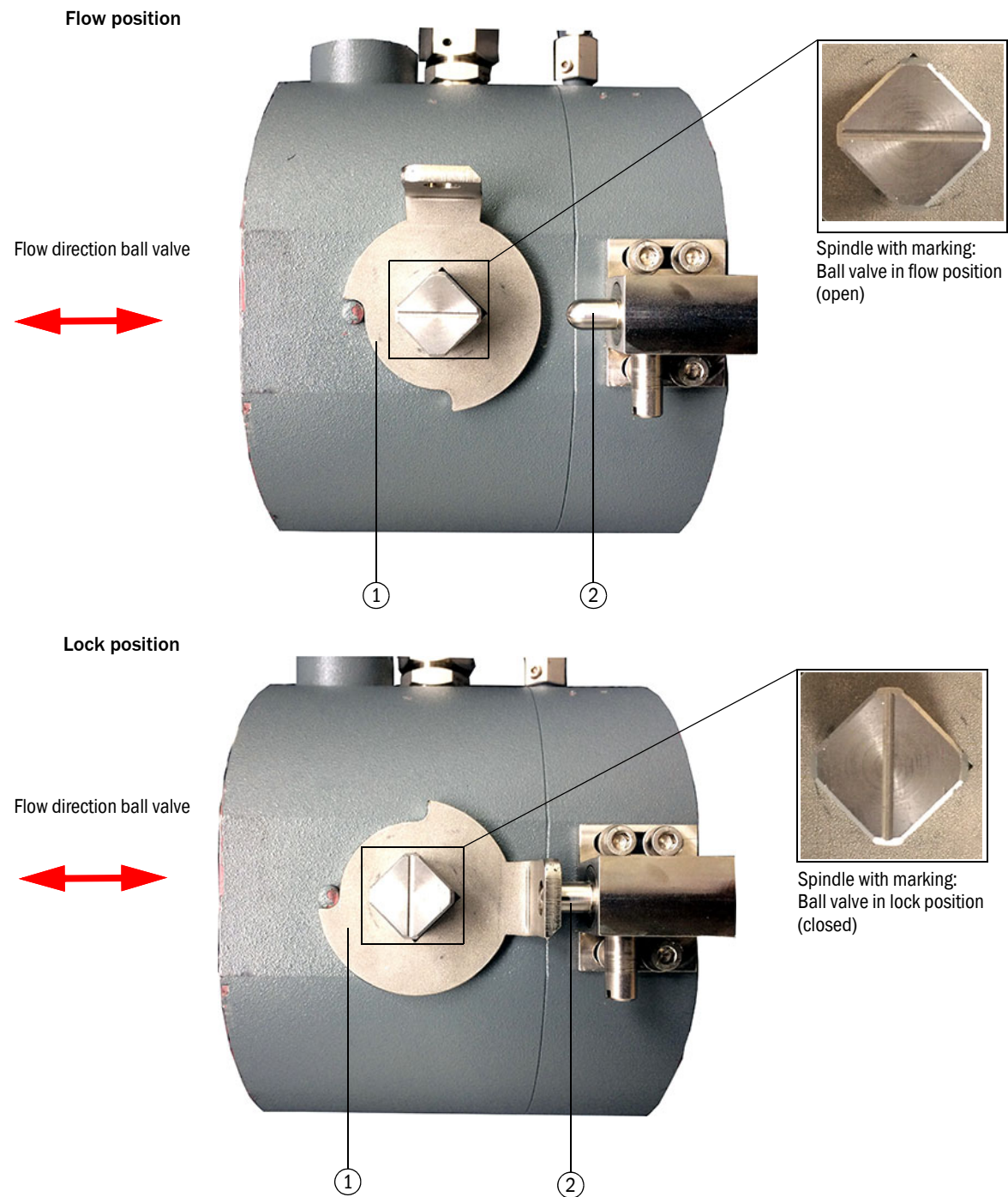

6.2.5

Checking the function of the pressure gauge on the ball valve



	<p>WARNING:</p> <ul style="list-style-type: none"> ▶ Only open the process connection of the pressure gauge in a pressure-free state.
	<p>NOTICE: Checking the function of the pressure gauge on the ball valve</p> <p>The pressure gauge on the ball valve is a battery-operated digital pressure gauge. Two 1.5 AA batteries serve as power supply for the pressure gauge. Operating time is approx. 4,000 hours when using batteries with a capacity of 2,000 mAh.</p> <p>Prior to each change procedure:</p> <ul style="list-style-type: none"> ▶ Check that the pressure gauge is generally ready for operation. Use is only allowed in a perfectly safe state. ▶ Check the charge level of the batteries. <ul style="list-style-type: none"> - Different to the Operating Instructions of the pressure gauge manufacturer, the battery symbol must show at least 2 bars (2 out of 3) for each change procedure (→ Fig. 32). - In case of low charge level, replace the batteries. Do not use the fitting tool when the charge level of the batteries is too low. <p style="text-align: right;">Refer to the Operating Instructions of the manufacturer for further information.</p>

Fig. 32

Battery symbol on the display – Shows the charge level of the batteries

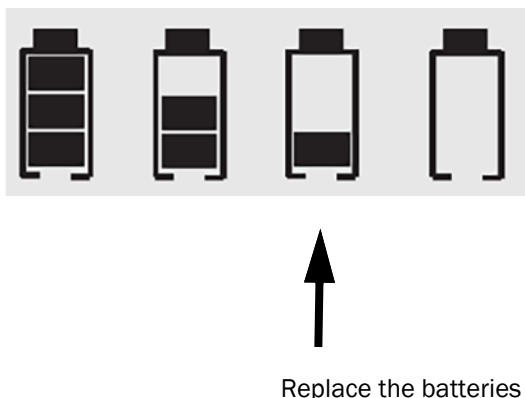

6.3

Installing the sender/receiver unit and ball valve

- ▶ Carry out once on each nozzle.

Information

- Fit the sender/receiver unit directly on the nozzle flange. It fastens the ultrasonic sensor. The sender/receiver unit is closed pressure-tight when an ultrasonic sensor is installed.
- When the ultrasonic sensors are to be installed with the pipeline in operation (hot tapping), the ball valve must be positioned and the fitting tool used. Fitting tool and ball valve form a pressure lock. Only use the fitting tool together with the ball valve.
- Information on safe use of the ball valve, see → p. 88, §6.2.4.
- An ultrasonic sensor must be fitted before the ball valve can be removed again.

Prerequisites

● Nozzles on the pipeline (→ p. 62, §4.2)
● SW 11 Allen key [1]
● SW 8 Allen key [2]

[1] For the toggle valve of the ball valve; *alternative*: metal rod or punch \varnothing 4.0 ... 4.5 mm.

[2] For the bypass valve of the ball valve.

Assembly material

The assembly material for installing the sender/receiver unit includes:

- 4 screws, M20 x 60, material stainless steel
- 8 washers, $\frac{3}{4}$ ", material steel, coated
- 1 serrated seal, material stainless steel/graphite
- Screw paste

Use the screw paste provided to prevent the fastening screws from "blocking".

Fig. 33

Assembly material

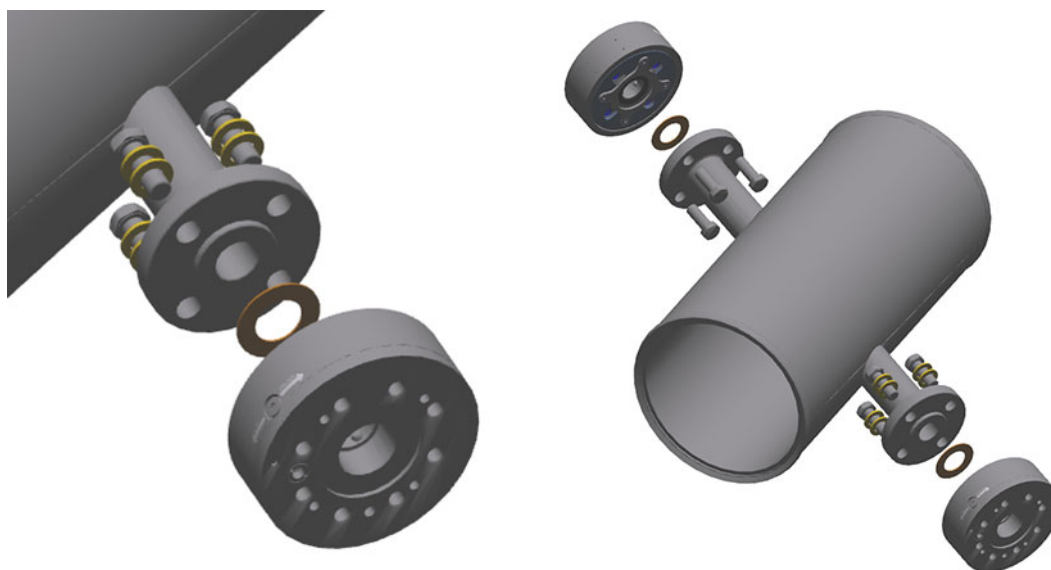

NOTICE:

Observe the following when fitting the enclosed flat seal:
 The seal is positioned correctly using a specially adapted centering ring which is pre-installed at the factory on the process connection of the S/R unit (→ Fig. 34).

- ▶ First remove the centering ring before fitting the seal.
 Loosen the fastening screws on the centering ring and remove the centering ring. Then place the seal on the process connection of the S/R unit and align it centrally.
- ▶ Re-install the centering ring and make sure the central position of the seal does not change.

Fig. 34

Process connection of the S/R unit with centering ring and installed flat seal

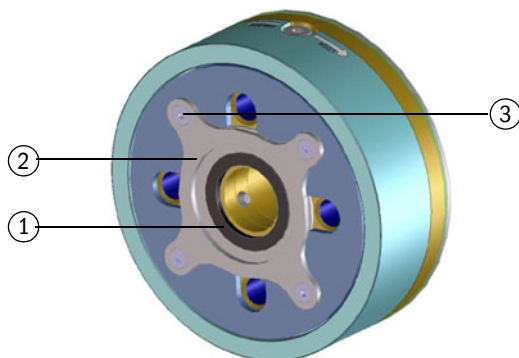

- 1 Flat seal in correctly installed position under the centering ring
- 2 Centering ring for flat seal
- 3 Fastening screws for centering ring

Procedure

- 1 Fitting the sender/receiver unit on the nozzle:
 - The safety pin on the locking ring (marked red) must be aligned upwards to enable convenient working with the fitting tool.
 - Check/clean sealing surfaces
 - Flat seal
 - 4 M20 x 55 screws
 - Tightening torque: 155 Nm (use a torque wrench)

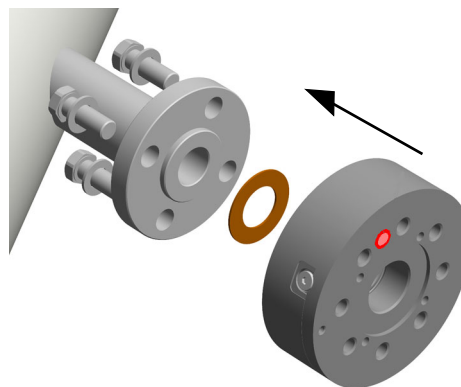

- 2 Remove the screw plugs on the locking ring of the sender/receiver unit.
- 3 Screw the handles in the locking ring of the sender/receiver unit.

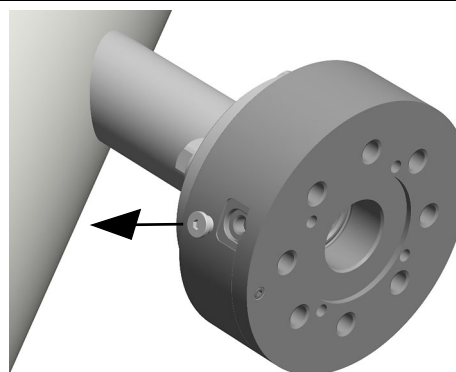

- 4 Loosen the release lock by pressing the safety pin down with a suitable tool

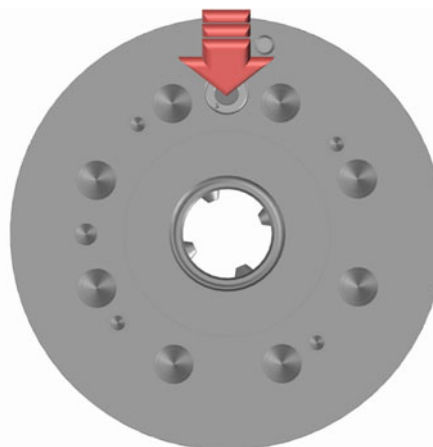

- 5** Unlock the sender/receiver unit:
- Grip both handles.
 - Turn the locking ring towards marking "UNLOCK" to the stop (75°).

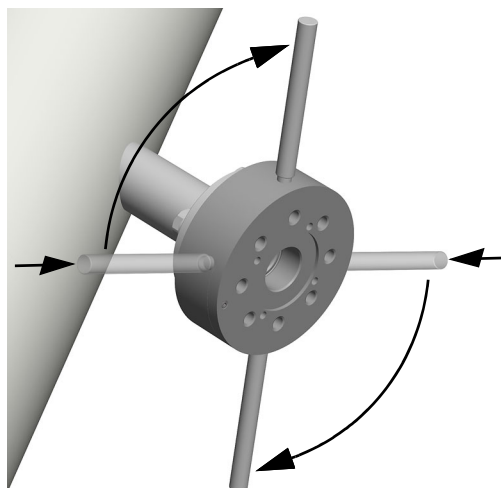

- 6** Fit the ball valve of the fitting tool on the locking ring.
- Check/clean sealing surfaces
 - Flat seal between ball valve and locking ring
 - Screws: M16 x 120
 - Tightening torque: 140 Nm (use a torque wrench)

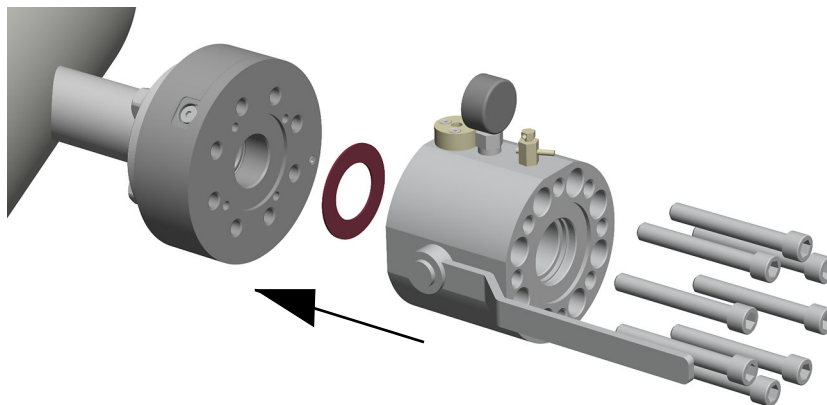

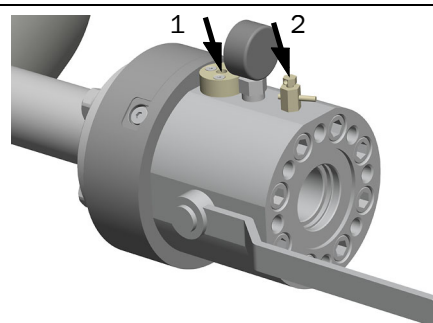

- 7** Prepare the ball valve:
- ▶ Close bypass valve (1).
 - ▶ Close toggle valve (2).
 - ▶ Check function (move lever).



6.4

Drilling the holes in the pipeline

	<p>WARNING: Hazards during hot tapping When sender/receiver units are installed on the pipeline when the pipeline is in operation (hot tapping):</p> <ul style="list-style-type: none"> ▶ Only have this work done by skilled persons qualified for hot tapping. ▶ Comply with all legal, general and company-internal regulations. ▶ Only start installation work when all planned measures have been checked and expressly approved by the plant operator.
	<p>WARNING: Risk of leakage due to contamination During the drilling process, drilling chips fall into the attachments (nozzle, transmitter/receiver unit, ball valve, etc.).</p> <ul style="list-style-type: none"> ▶ After drilling, clean all attachments in a suitable manner. Drilling chips and other contamination must be completely removed before installing the sensors. Endress+Hauser does not assume any warranty for the consequences of contamination of pipelines or attachments.

Only once on each nozzle.

- ▶ Drill a hole in the pipeline in the center of the nozzle position.
 - Fasten a suitable drilling tool on the ball valve.
 - Hole diameter: $D_{min} = 30\text{ mm}$, $D_{max} = 35\text{ mm}$

 This work requires special tools (hot tapping tool) and special technical knowledge.

- ▶ Before installing the sensors according to → p. 95, § 6.5 clean all attached parts in a suitable manner.

Fig. 35

Hot tapping illustration

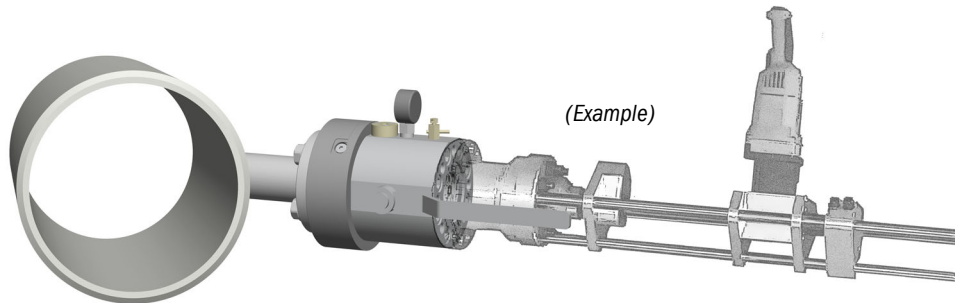

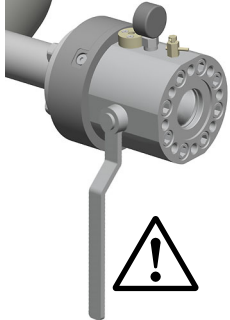
	<p>WARNING: Accident risk When the hole is ready: Gas flows through the pipeline when the ball valve is opened.</p> <ul style="list-style-type: none"> ▶ Keep the ball valve closed and fitted until an ultrasonic sensor has been fitted (procedure → p. 95, § 6.5). ▶ Secure the ball valve against unintentional activation (use lever lock on ball valve). ▶ Instruct other persons accordingly. ▶ Information on safe use of the ball valve, see → p. 88, § 6.2.4. ▶ Check the function of the pressure gauge on the ball valve, → p. 89, § 6.2.5. 	
---	---	---

6.5

Fitting an ultrasonic sensor with fitting tool



Only valid for hot tapping installation (normal procedure → p. 79, §5.2.3).

- ▶ Carry out once on each nozzle.

Prerequisites

● FLOWSIC300 fitting tool available and ready for use	→ p. 30, §2.5.2
● Nozzle installed gas-tight on pipeline	→ p. 62, §4.2
● Hole for ultrasonic path in pipeline drilled correctly; following the drilling, the pipeline and the attachments were cleaned in a suitable manner	→ p. 94, §6.4
● Sender/receiver unit fitted on nozzle and locked	→ p. 90, §6.3
● Ball valve of fitting tool fitted on sender/receiver unit and locked	→ p. 90, §6.3

Information

WARNING: Hazardous gas (possibly explosive or toxic)

When the ultrasonic sensors are removed and fitted, a significant volume of process gas (up to 120 dm³ with 100 bar/up to 12 dm³ with 10 bar) escapes via the toggle valve when the fitting tool is vented. The escaping process gas must be channeled off safely via the toggle valve (e.g. into a suitable container).

Due to the measurement uncertainty of the pressure gauge used of ±0.8 bar, the displayed pressure value can deviate from the actual pressure value by up to 0.8 bar.

With a display value of 0 bar, there may still be a pressure of up to 0.8 bar(g) in the pipeline. Conversely, with a display of 0.8 bar, ambient pressure can already prevail in the pipeline.

The residual volume in the ball valve to be expected when dismantling the ball valve can therefore deviate accordingly.

- ▶ *On plants with toxic gases or gases otherwise harmful to health:* Take appropriate protective measures to avoid health damage.
- ▶ *On plants with explosive gases:* Take appropriate protective measures to exclude risk of explosion.

Step 1: Preparations**CAUTION: Accident risk**

As long as an ultrasonic sensor is not installed:
Gas flows through the pipeline when the ball valve is opened.

- ▶ Keep the ball valve closed and fitted until an ultrasonic sensor has been fitted.
- ▶ Secure the ball valve against unintentional activation (use lever lock on ball valve).
- ▶ Instruct other persons accordingly.
- ▶ Information on safe use of the ball valve, see → p. 88, §6.2.4.
- ▶ Check the function of the pressure gauge on the ball valve, → p. 89, §6.2.5.

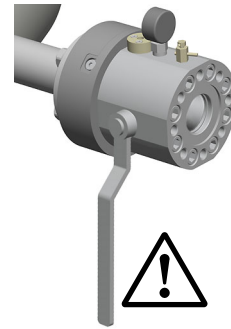

- 1 Switch the hydraulic cylinder coupling to "Fit" (procedure → p. 86, §6.2.3).

- ▶ The ultrasonic probe must not engage on the hydraulic piston during installation.
- ▶ When applicable, check with the ultrasonic probe that it does not engage.

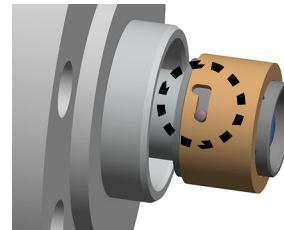

- 2 Inspect the sealing ring (O-ring on ultrasonic sensor):

- If the sealing ring is damaged: Replace the sealing ring.
- If the sealing ring is not greased: Clean the O-ring and apply a greasy film.

- 3 Place the ultrasonic sensor in the hydraulic cylinder:

- Open the pressure valve of the hydraulic pump.
- Push the hydraulic piston in the hydraulic cylinder (use the plastic or wooden rod provided on delivery).
- Let the ultrasonic sensor slide into the hydraulic cylinder to the stop as shown below.

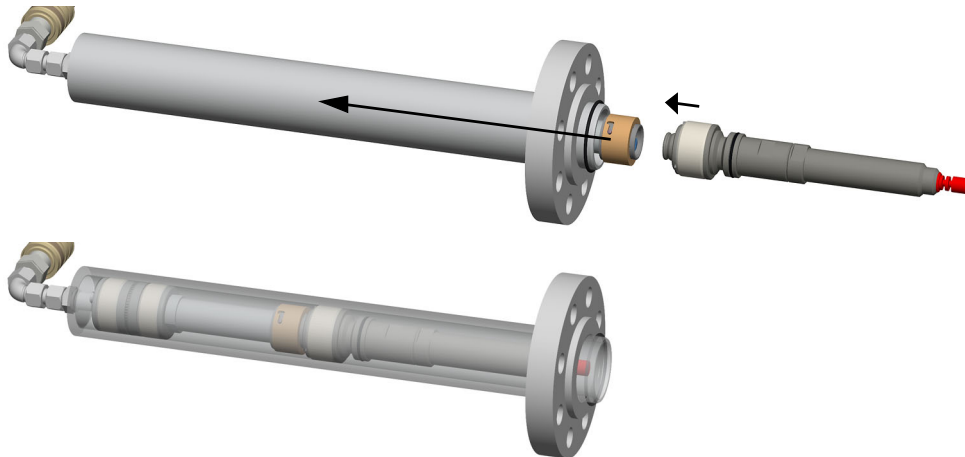

Step 2: Position the hydraulic cylinder

- 1 Position the hydraulic cylinder (with ultrasonic sensor inside) onto the ball valve.
 - Check/clean sealing surfaces and sealing ring (O-ring) of the hydraulic cylinder. Replace the sealing ring when necessary.
 - Tighten 8 screws M16 x 45, tightening torque approx. 20 Nm (O-ring ensures leak tightness).

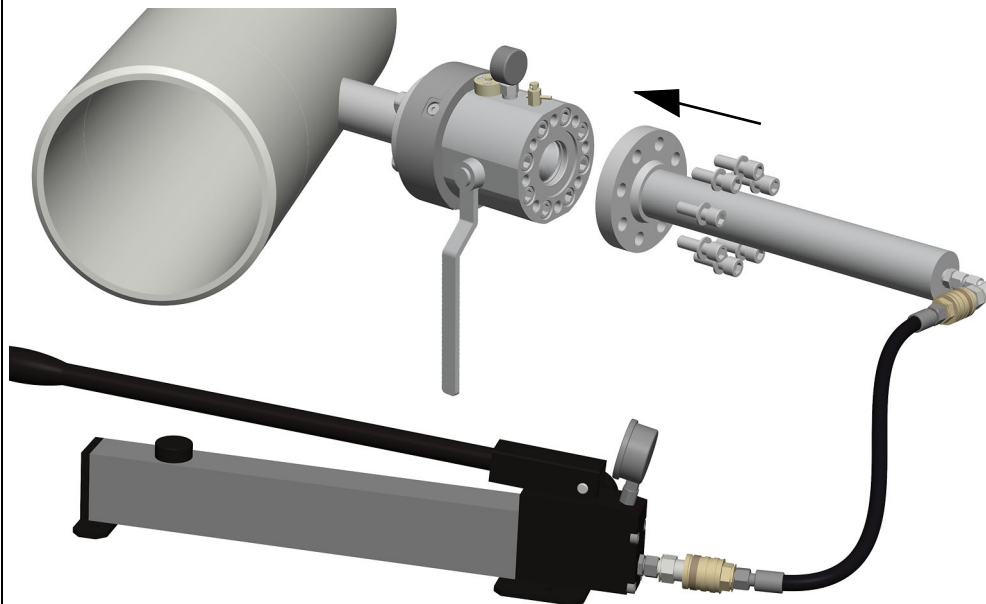

Note: One of the fastening screws releases the locking mechanism of the sender/receiver unit.

- 2 Compensate the pressure:
 - Slowly open the bypass valve of the ball valve.
 - Wait until the pressure display on the ball valve remains constant (pipeline pressure).
 - If the pressure on the pressure gauge is implausible, check for correct installation and function of all components.
 - Close the bypass valve.

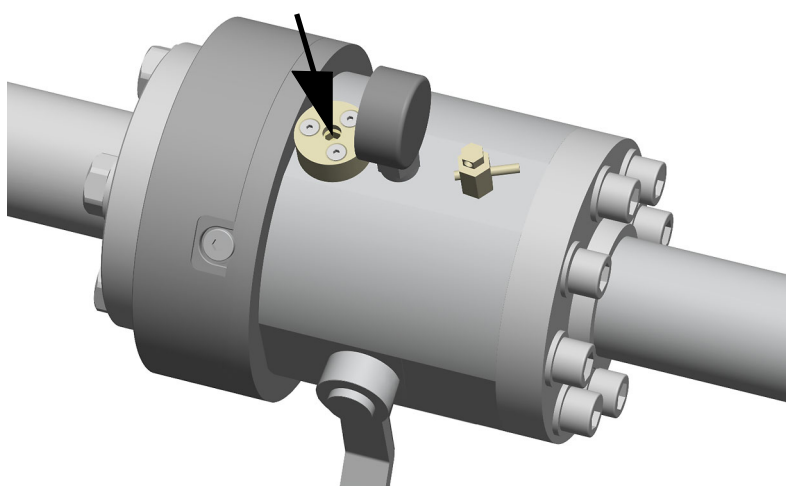

3 Slowly open the ball valve to the stop.

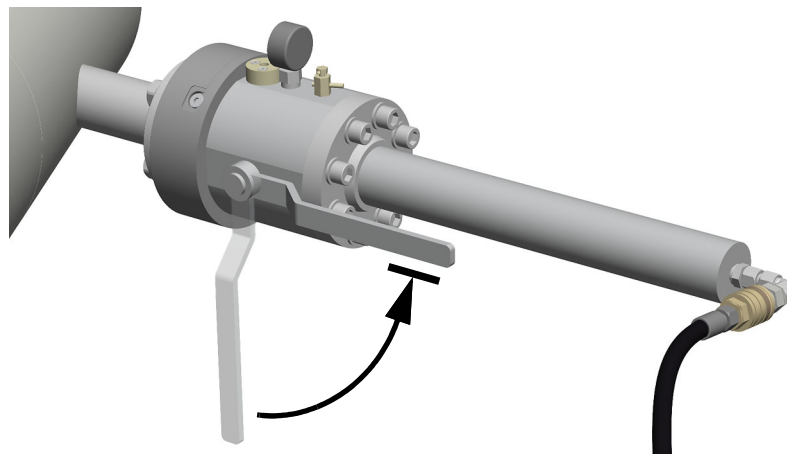

Step 3: Fit the ultrasonic sensor

- 1 Remove the screw plugs of the locking ring of the sender/receiver unit.
- 2 Screw the handles in the locking ring.

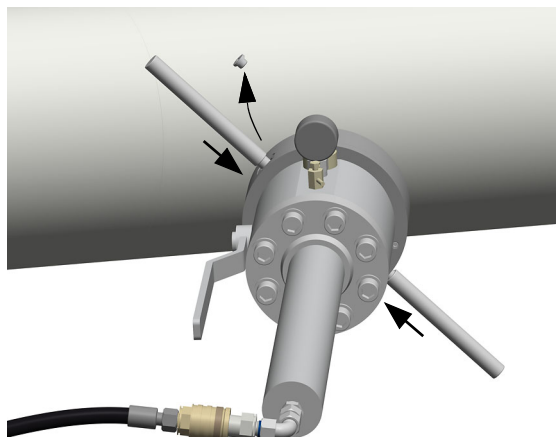

- 3 Unlock the sender/receiver unit (if not already done so):
 - Grip both handles.
 - Turn the locking ring of the sender/receiver unit towards marking “UNLOCK” to the stop (75°).

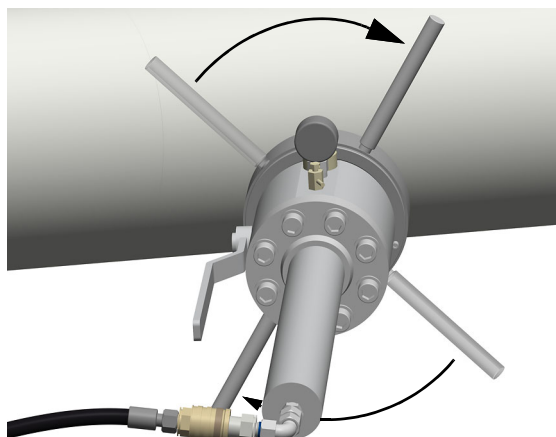

WARNING: Hazardous gas (possibly explosive or toxic)

When the ultrasonic sensors are removed and installed, a significant amount of process gas escapes via the toggle valve (up to 120 dm³ at 100 bar/up to 12 dm³ at 10 bar) when the exchange tool is vented.



▶ See information → p. 95, §6.5.

4 Push the ultrasonic sensor into the sender/receiver unit:

- Close pressure valve (P) of the hydraulic pump.
- Watch the hydraulic pressure on the pressure gauge of the hydraulic pump. Pump carefully until the hydraulic pressure rises above the pressure displayed on the ball valve (= pressure in pipeline).

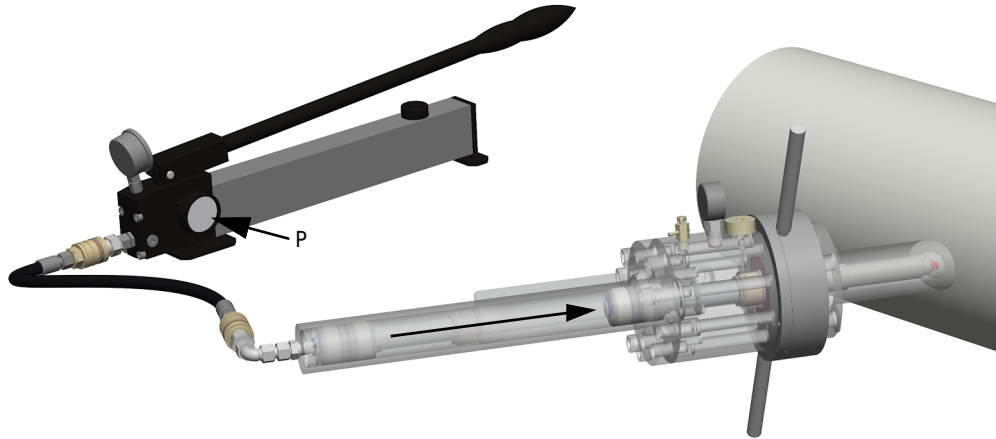

- The hydraulic pressure must overcome the pipeline pressure.
- The ultrasonic sensor is in the end position (hydraulic piston can no longer be moved) when the hydraulic pressure rises clearly above the pipeline pressure.
- The hydraulic pump has a safety valve against overpressure.
- The pipeline is sealed by the sender/receiver unit when the ultrasonic sensor is fitted and locked.



NOTICE: Pressure build-up too low on the pressure gauge

If no or not enough pressure is built up on the pressure gauge of the hydraulic pump when an ultrasonic sensor is fitted, this may be due to air in the hydraulic system. The sensor will then not reach the end position because of the compressibility of the air.

In this case, terminate fitting and proceed as described below.

- ▶ Slowly open the pressure valve of the hydraulic pump slightly and listen to the sound of the retracting hydraulic piston.
After complete relief of the hydraulic cylinder, the pressure gauge of the pump must show zero bar
- ▶ Close the locking unit.
 - Grip both handles.
 - Turn the locking ring handles towards marking "LOCK" to the stop and unscrew them afterwards.
- ▶ Close the ball valve.
- ▶ Close the bypass valve on the ball valve.
- ▶ Slowly open the toggle valve on the ball valve and ensure complete pressure relief in the hydraulic cylinder of the fitting tool.
- ▶ Close the toggle valve again.

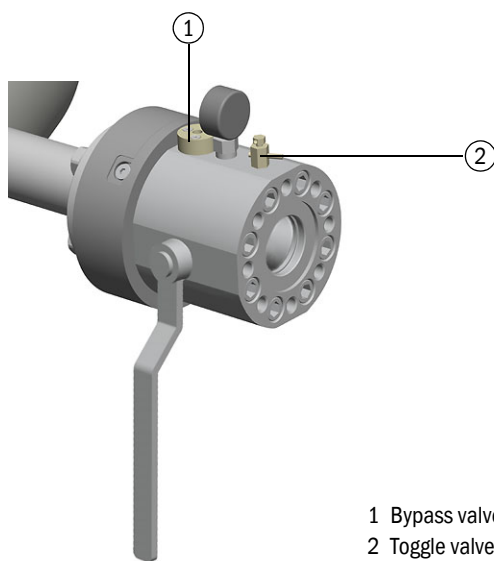

- ▶ Disassemble the hydraulic cylinder of the fitting tool.
- ▶ Make sure that the ultrasonic sensor in the hydraulic cylinder is loose!
- ▶ Carefully let the ultrasonic sensor slide out.
- ▶ Before attempting to fit the ultrasonic sensor again, check the movement range of the cylinder as described in → p. 86, §6.2.3.

5 Lock the sender/receiver unit:

- Grip both handles.
- Turn the locking ring handles towards marking "LOCK" to the stop.
- Unscrew the handles.

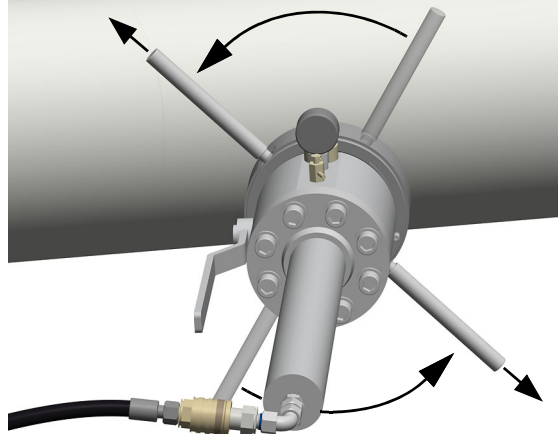

- Refit the screw plugs.

Step 4: Remove the fitting tool**1** Let the hydraulic piston slide back:

- Slowly open pressure valve (P) of the hydraulic pump slightly. Listen to the sound of the retracting hydraulic piston.
- *When the hydraulic piston is in the end position:* Open the pressure valve of the hydraulic pump completely.

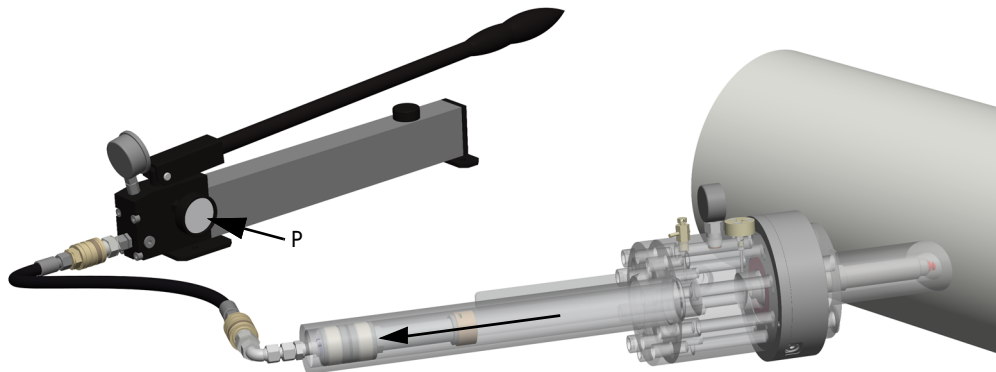
**WARNING: Hazardous gas (possibly explosive or toxic)**

When the ultrasonic sensors are removed and installed, a significant amount of process gas escapes via the toggle valve (up to 120 dm³ at 100 bar/up to 12 dm³ at 10 bar) when the exchange tool is vented.



► See information → p. 95, §6.5.

- 2 Relieve the pressure:
- Slowly open the toggle valve of the ball valve.
 - Wait until the pressure display on the ball valve remains constant (ambient pressure).
 - Close the toggle valve again.

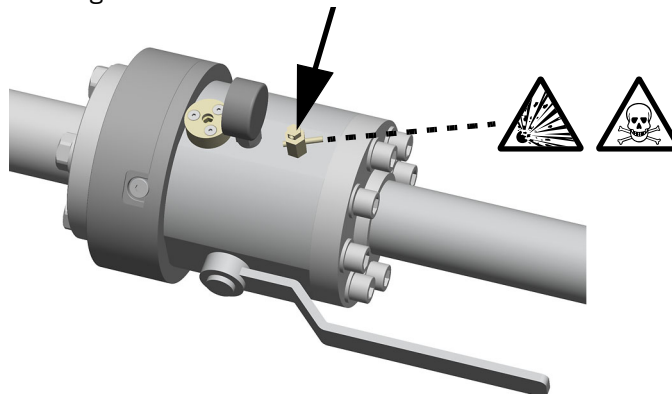

- 3 Remove the hydraulic cylinder.

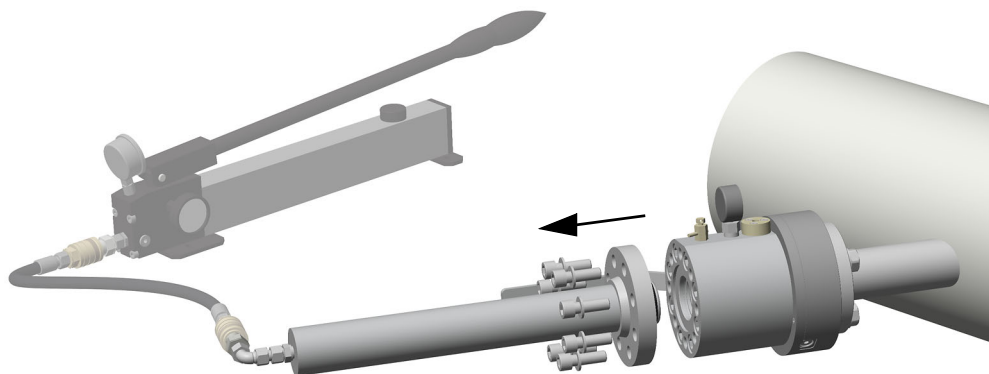

- ▶ Separate the hydraulic pump from the hydraulic cylinder as required.

- 4 Remove the ball valve.

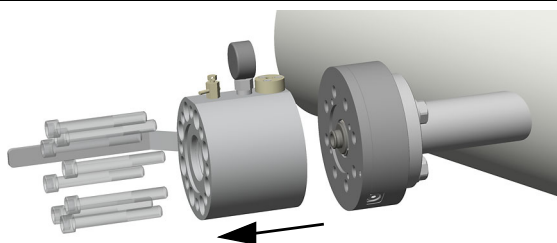

- 5 Check that the sender/receiver unit is gas-tight.



WARNING: Hazards through leaks

Operation in leaky condition is not allowed and possibly dangerous.

If gas escapes from the sender/receiver unit:



- 1 Remove the ultrasonic sensor again (see Service Manual);
- 2 Check the sealing ring on the ultrasonic sensor and renew as required.
- 3 Then carefully refit the ultrasonic sensor.

Step 5: Fit the cover

- 1 Pull the probe connection cable from the ultrasonic sensor.
- 2 Connect the probe connection cable on the inside of the enclosure cover.
- 3 Check the enclosure cover seal for damage.
- 4 Fit the enclosure cover with the 4 screws.

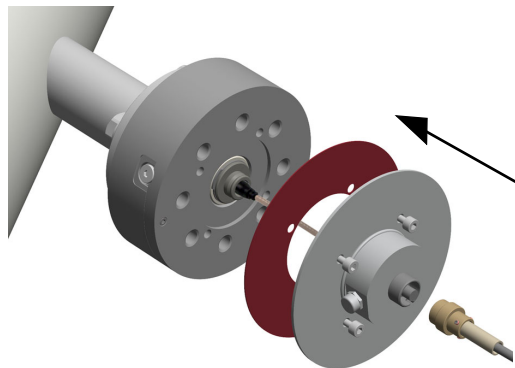

- 5 *If fitted:* Connect the connection cable to the SPU to the outside of the enclosure cover.

**WARNING:**

Only remove the ultrasonic sensors according to the instructions in the "Service Manual" for the FLOWSIC300.

FLOWSIC300

7 Installing the electronics unit

Fitting the electronics unit
Cable specifications
Electrical installation
Information on safe operation

7.1 Fitting the electronics unit

7.1.1 Fitting information

- The connection cables between the electronics unit and sender/receiver unit are maximum 15 m long.
- Voltage supply, signal lines and interfaces are connected to the rear side of the SPU (→ p. 112, § 7.2.4).
- The SPU can be turned (→ p. 108, § 7.1.4).
- The junction box below the signal processing unit need not be opened.

**NOTICE: Risk of damage**

- ▶ Fasten load nozzle equipment (when used) to the assembly lugs of the electronics unit.
Otherwise the SPU can be damaged.

7.1.2 Installation location requirements

- ▶ Install the electronics unit in a protected location that is easily accessible.
- ▶ Consider space requirements for plugs and cables.
- ▶ Select an installation location free from vibrations.
- ▶ Comply with the permissible ambient temperature (→ p. 179, § 12.2). Shield against heat radiation from other objects.
- ▶ Protect against direct sunlight. *Recommendation:* Fit weather protection when installing outdoors (e.g. corrugated roof).
- ▶ Select an installation location free of chemical influence.

7.1.3 Fastening the electronics unit

Fig. 36 Electronics unit

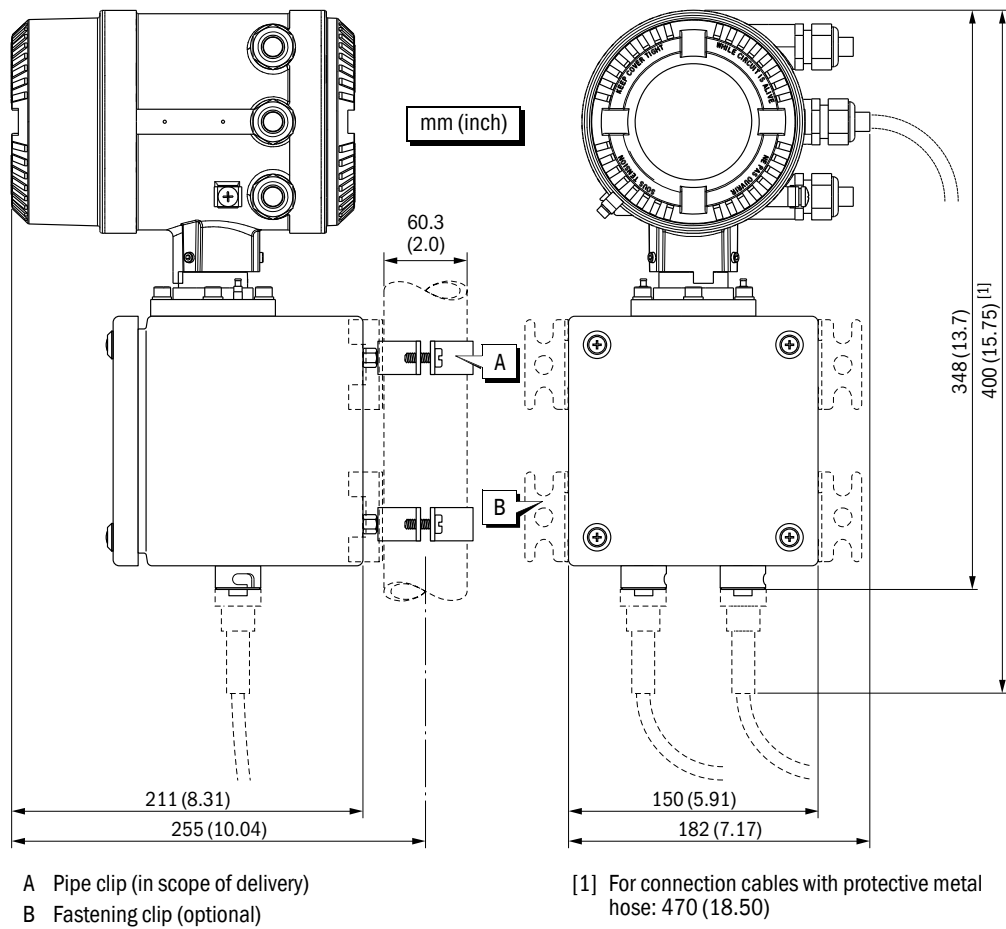
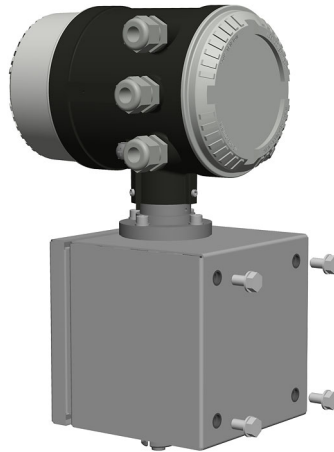

Table 2 Fastening methods for the electronics units

Fastening method	Procedure
Pipe clips	► Fasten the rear side of the electronics unit to a vertical 2 inch pipe with the pipe clips (→ Fig. 36).
Threaded bushes	1 Remove the pipe clips. 2 Use the threaded bushes (M8) on the rear side (→ p. 108, Fig. 37).
Assembly lugs	1 Remove the pipe clips. 2 Fit the optional fastening clips to the rear side and use for fastening.

Fig. 37 Threaded bushes on the rear side of the electronics unit



7.1.4 Turning the SPU

After loosening the locating screw, the SPU can be turned for better access (→ Fig. 38).

Fig. 38 Turning the SPU.

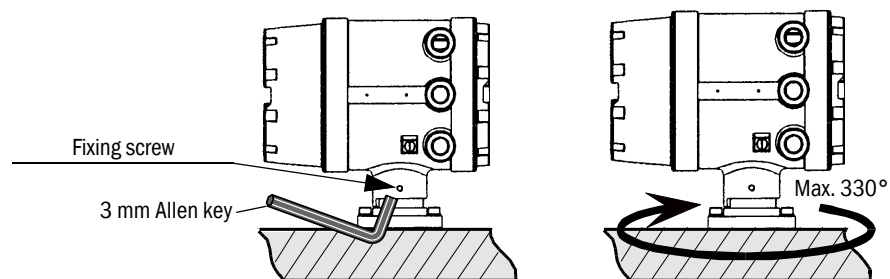

NOTICE:

- ▶ Secure the selected position.

7.1.5 Connecting the connection cable

Carry out once for each sender/receiver unit:

- ▶ Lay the connection cable between the sender/receiver unit and electronics unit (→ p. 24, Fig. 2).
- ▶ Connect the cable at both ends. Use the lock of the plug system.

7.2 **Electrical installation**

 Work required for the electrical installation of the FLOWSIC300 (laying and connecting the power supply cable and signal lines) is not part of the scope of delivery.

7.2.1 **General information**

Prerequisites

- ▶ Fully complete installation work of the sender/receiver units (see as from p. 60, §4.1).
- ▶ Comply with cable specifications (→ p. 110, § 7.2.2).

External main switch (main power switch)

- ▶ Install a switch close to the device to be able to switch the auxiliary voltage of the FLOWSIC300 on and off.

 The FLOWSIC300 does not have an own main switch. European standard EN 61010 specifies that any fix-mounted devices not having an own main power switch must be equipped with an external main power switch.

Laying cables

- ▶ Protect cables against mechanical damage (install in cable ducts or tubes).
- ▶ Observe permissible bending radii for cables (standard for multilead cables: 6x cable diameter).
- ▶ Keep connections to cable harnesses or shields as short as possible.
- ▶ Lay the probe connection cables separate from cables carrying voltage.
- ▶ Lay the probe connection cables separately to prevent electromagnetic interference.
- ▶ Lay all cables so that no hazard exists for the intrinsic safety of FLOWSIC300.

 **WARNING: Danger**

- ▶ Always observe the general safety regulations and safety instructions given in Section 1 when carrying out any installation work.
- ▶ Installation work shall only be carried out by trained staff and in accordance with the relevant regulations issued by the operating company.
- ▶ Take all necessary precautions to avoid local or plant-specific dangers.

7.2.2

Cable specifications**WARNING: Hazards through wrong cables**

Cables must meet the requirements for potentially explosive atmospheres (see e.g. EN 60079-14 and other relevant standards).

- ▶ Only use cables suitable for use in the respective potentially explosive atmosphere.

Power supply

	Specification	Remark
Cable type	Two leads	Ground the shielding (if present) on one side.
Min./ max. cross-section	0.5 mm ² / 2.5 mm ² (20 to 12 AWG)	
Maximum cable length	Depending on loop resistance; Minimum input voltage on FLOWSIC300 12 V	Max. current 150 mA (peaks)
Cable diameter	6 ... 12 mm	Fixing range of cable glands



Auxiliary voltage specification → p. 179, § 12.2

Digital output / current output

	Specification	Remark
Cable type	Twisted pair, shielded	Connect shielding at other end to ground terminal
Min./ max. cross-section	2 x 0.5 mm ² (2 x 20 AWG) / 1 mm ² (2x 20-18 AWG)	Do not connect unused conductor pairs and prevent them from accidental short-circuit
Maximum cable length	Loop resistance including load ≤ 200 Ω	
Cable diameter	6 ... 12 mm	Fixing range of cable glands

Serial port (RS485)

	Specification	Remark
Cable type	Twisted pair, shielded, cable impedance approx. 100 ... 150 W, low cable capacitance: ≤ 100 pF/m	Connect shielding at other end to ground terminal
Min./ max. cross-section	2 x 0.5 mm ² (2 x 20 AWG) / 1 mm ² (2x 20-18 AWG)	
Maximum cable length	- 300 m at 0.5 mm ² (20 AWG) - 750 m at 0.75 mm ² (18 AWG)	Do not connect unused conductor pairs and prevent them from accidental short-circuit
Cable diameter	6 ... 12 mm	Fixing range of cable glands

7.2.3

Checking the cable loops

Check the cable loops to verify that the cables are connected correctly. Proceed as follows:

- ▶ Disconnect both ends of the cable of the loop to be tested.
This is to prevent connected devices from interfering with the measurement.
- ▶ Test the entire cable loop between electronics unit and terminal device by measuring the loop resistance.
- ▶ *When the insulation resistance of the cable loops is to be checked:* Disconnect the cables from the electronics unit before using the insulation test device. Reconnect cables after the test.



WARNING: Risk of explosions in potentially explosive atmospheres

Before opening the rear enclosure cover (Exe terminal compartment) and before connecting or disconnecting lines:

- ▶ Establish a state disconnected from the mains and potential-free. [1]

[1] Not applicable for intrinsically safe installations.



WARNING: Risk of explosions in potentially explosive atmospheres

Before opening the front enclosure cover (with front window) of the SPU:

- ▶ Establish a state disconnected from the mains and potential-free.
- ▶ Switch the FLOWSIC300 off (interrupt auxiliary voltage) and then wait at least 10 minutes.



NOTICE:

Incorrect cabling may cause failure of the FLOWSIC300! This will invalidate warranty claims. The manufacturer assumes no liability for consequential damage.

7.2.4 **SPU terminal compartment**

Opening the rear enclosure cover

- ▶ Loosen the securing clip using a 3 mm Allen key.
- ▶ Turn the rear enclosure cover counterclockwise and take it off.

 **NOTICE:**

- ▶ Only use "LOCTITE 8156" as lubricant for the enclosure cover.

The connection plan is shown on the inside of the cover (schematic).

Fig. 39 SPU housing

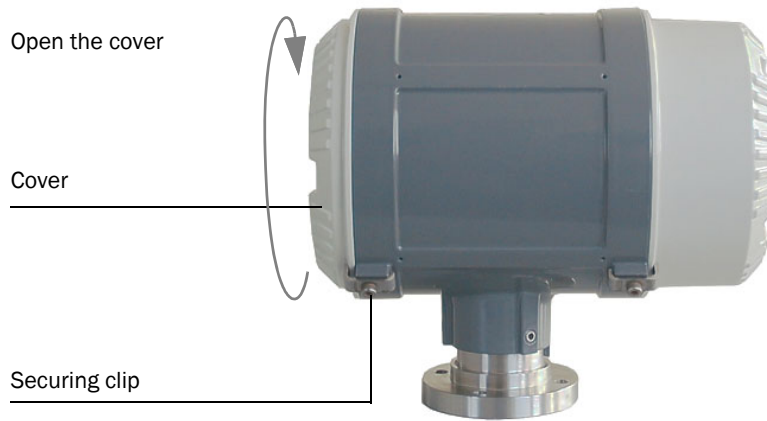

Fig. 40 Terminal compartment at the rear of the SPU (see Section → §7.2.2 for North American wiring specification equivalents)

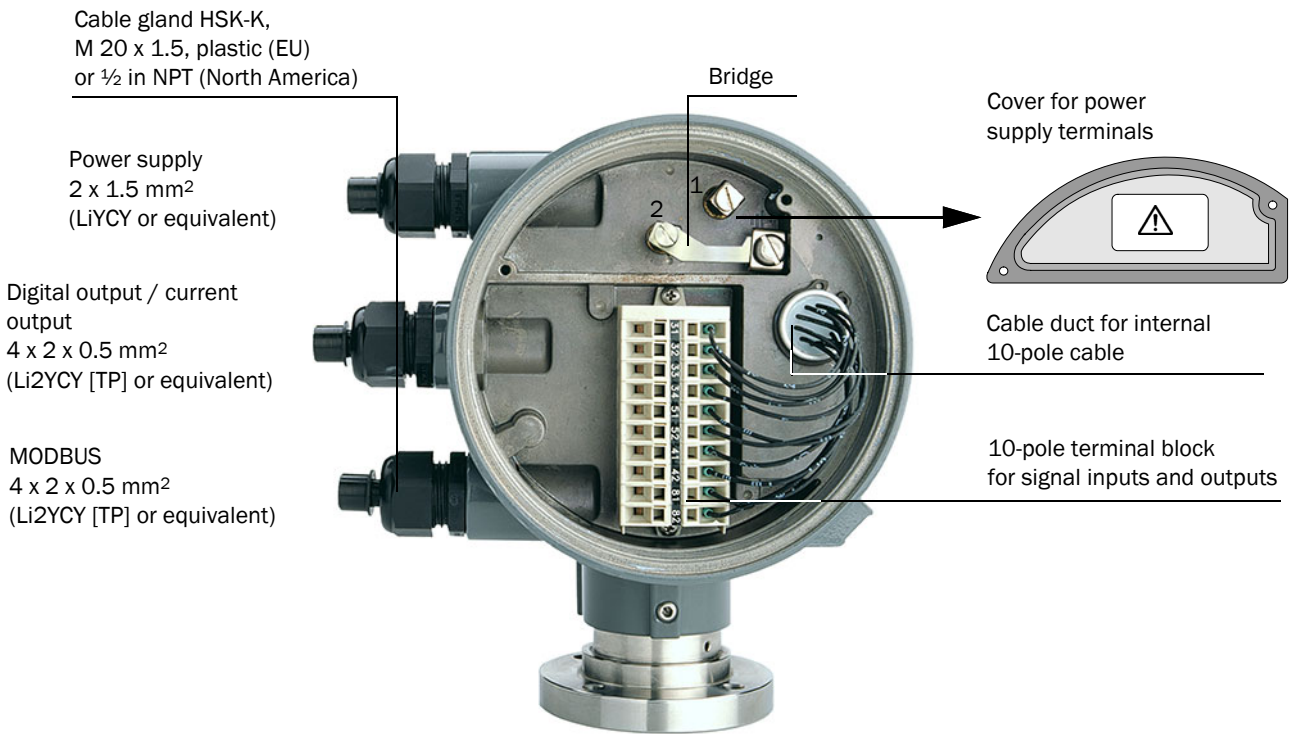
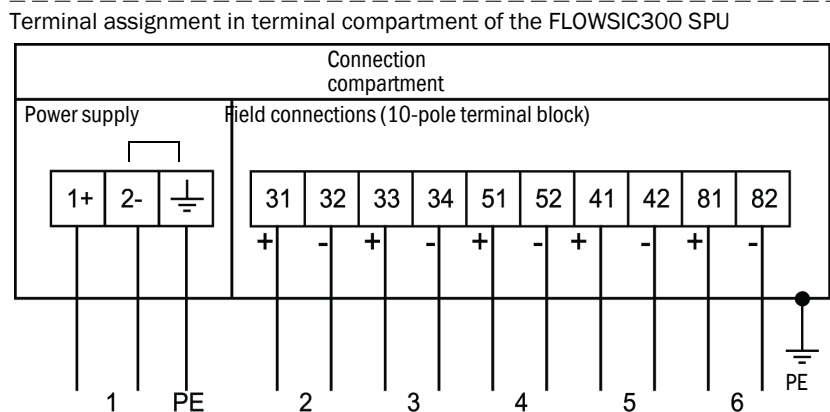

Fig. 41



+i Terminals 2 and PE are bridged internally, i.e. there is no galvanic separation between PE and negative potential (see → Fig. 40).

7.2.5 Terminal assignment

Assign the terminals in the SPU connection compartment (→ Fig. 41) as shown in the following Table.

No.	Connection for	Function	Terminal	Value	Remark
1	Power supply		1+, 2-	→ p. 179, § 12.2	
2	Analog output	Active HART bus	31, 32	4...20 mA, $R_L < 250 \Omega$ 1200 baud, 8 data bits, odd parity, 1 stop bit	
3	Serial port	Modbus (RS485)	33, 34	9600 baud, 8 data bits, no parity, 1 stop bit	Baud rate to be set through software
4	Digital output DO 1 (HF 1)	Passive	51, 52	$f_{\max} = 6 \text{ kHz}$, pulse width 0.05 s - 1 s Range: Variable number of pulses per volume unit "closed": $0 \text{ V} \leq U_{CE L} \leq 2 \text{ V}$, $2 \text{ mA} \leq I_{CE L} \leq 20 \text{ mA}$ (L=Low) "open": $16 \text{ V} \leq U_{CE H} \leq 30 \text{ V}$, $0 \text{ mA} \leq I_{CE H} \leq 0.2 \text{ mA}$ (H=High)	With NAMUR contact for connection to switching amplifier (to DIN 19234)
5	Digital output DO 2	Passive	41, 42	"closed": $0 \text{ V} \leq U_{CE L} \leq 2 \text{ V}$, $2 \text{ mA} \leq I_{CE L} \leq 20 \text{ mA}$ (L=Low) "open": $16 \text{ V} \leq U_{CE H} \leq 30 \text{ V}$, $0 \text{ mA} \leq I_{CE H} \leq 0.2 \text{ mA}$ (H=High) "Check request" (standard)	
6	Digital output DO 3	Passive	81, 82	"closed": $0 \text{ V} \leq U_{CE L} \leq 2 \text{ V}$, $2 \text{ mA} \leq I_{CE L} \leq 20 \text{ mA}$ (L=Low) "open": $16 \text{ V} \leq U_{CE H} \leq 30 \text{ V}$, $0 \text{ mA} \leq I_{CE H} \leq 0.2 \text{ mA}$ (H=High) "Flow direction" (standard) (alternative "Warning")	

**NOTICE:**

Within explosion-protected areas, the FLOWSIC300 must be connected via ground terminals with the equipotential bonding system.

- ▶ For measurement reasons, the equipotential bonding must, as far as possible, be identical to the pipeline potential or protective ground.
- ▶ Additional grounding with the protective conductor via the terminals is not permitted!

**NOTICE:**

The connections of the ultrasonic sensors are electrically intrinsically safe and are safely separated from one another and from other non-intrinsically safe power circuits.

The sensors may be connected and disconnected during operation as long as the safe separation of circuits has been preserved in every respect.

- ▶ In order to ensure this, the respective sensor connection cable should be disconnected at both ends (disconnect the electronics side first, and then if necessary, the sensor side unless the TNC connector is suitably fixed to prevent any uncontrolled movement).
- ▶ Operation using sensors or cables not part of the original delivery or with sensors/components from other manufacturers is not permitted.

7.2.6

Requirements for use in hazardous areas with potentially explosive atmospheres

Intended use

The FLOWSIC300 is suitable for use in hazardous areas classified as Zone 1 and Zone 2.

Certification in accordance with ATEX

Ⓔ II 1/2 G Ex db eb ib [ia Ga] IIC T4 Ga/Gb

Ⓔ II 1/2 G Ex db eb ib [ia Ga] IIA T4 Ga/Gb

Permitted ambient temperature range -40 °C to +60 °C

EU Type Examination Certificate_ TÜV 10 ATEX 556259 X

IECEX certification

Ex d e ib [ia Ga] IIC T4 Ga/Gb

Ex d e ib [ia Ga] IIA T4 Ga/Gb

Permitted ambient temperature range -40 °C to +60 °C

IECEX Certificate (Certificate of Conformity): see type plate FLOWSIC300

	<p>NOTICE:</p> <ul style="list-style-type: none"> ▶ The joints of the SPU housing that are proof against the transmission of internal ignition exceed the requirements in EN/IEC60079-1. ▶ Repair of joints that are proof against the transmission of internal ignition is not intended. ▶ Contact the manufacturer when you need the dimension specifications for the joints that are proof against the transmission of internal ignition (see §5.1 EN 60079-1).
---	--

Fig. 42

FLOWSIC300 components and their type of protection

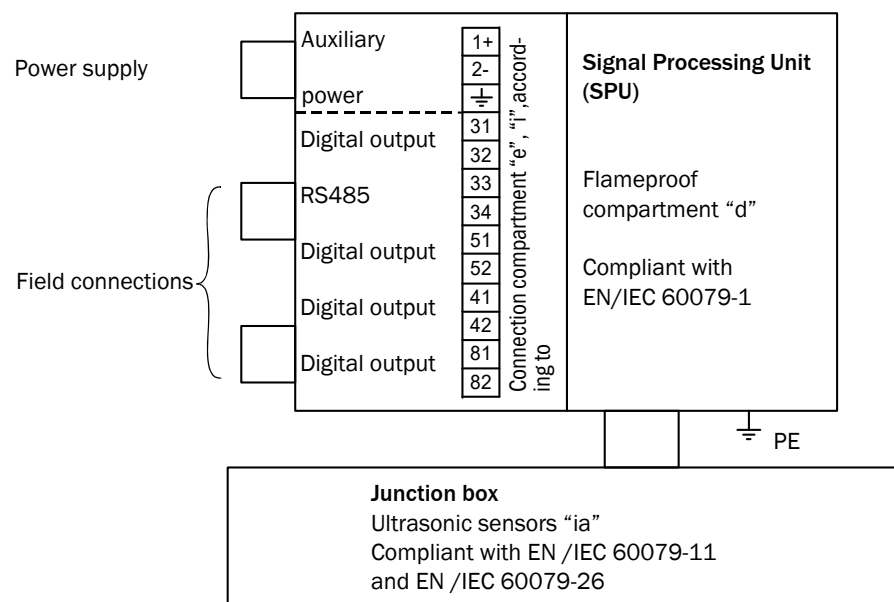

Operating conditions for the ultrasonic sensors

The FLOWVIC300 is designed for use in hazardous areas with potentially explosive atmospheres only under normal atmospheric conditions. The atmospheric conditions must be within the following ranges:

- Ambient pressure range 80 kPa (0.8 bar) to 110 kPa (1.1 bar)
- Air with normal oxygen content, typically 21% v/v

The ambient temperature must be within the range specified at the SPU type plate, e.g. -40 °C to +60 °C.

Once the FLOWVIC300 is installed in the pipeline, the SPU becomes a part of the pipeline. The wall of the pipeline and the meter body is then deemed a zone-separating barrier. The figure below helps in understanding the different situations for a possible application and shows what operating conditions apply.

Fig. 43

Ex-Zones

Case 1:

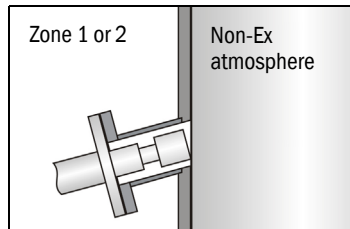

- The pipeline contains a non-explosive mixture. The gas mixture may be combustible.
- Gas pressure and gas temperature may be within the range specified by the tag on the meter body.

Case 2:

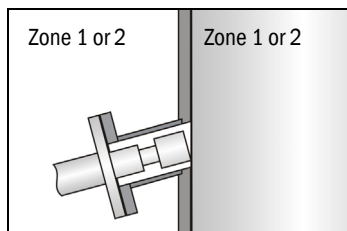

- The area inside the pipeline is classified as hazardous area Zone 1 or 2.
- Gas pressure must be in the range from 80 kPa to 110 kPa (normal atmospheric condition).
- Gas temperature must be within the permitted ambient temperature range specified by the type plate on the SPU.

Case 3:

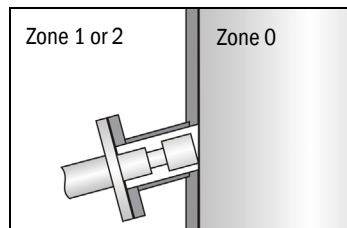

- The area inside the pipeline is classified as hazardous area Zone 0.
- Gas pressure must be in the range from 80 kPa to 110 kPa (normal atmospheric condition).
- Gas temperature must be in the range from -20 °C to 60 °C.

Additional requirements for operation of ultrasonic sensor in Zone 0 classified areas



WARNING: Ignition hazard by impacts or friction

The ultrasonic transducers of FLOWSIC300 are made of titanium. In rare cases, ignitable sparks due to impact and friction sparks could occur.

- ▶ The user must ensure that the ultrasonic transducers are adequately protected from hazards caused by impacts. This is especially true when the ultrasonic transducers of FLOWSIC300 are installed in zone 0 (see § 8.3 EN 60079-0).



WARNING: Ignition hazard by impacts

The maximum piezoelectric energy that can be released through impacts on the ultrasonic transducers exceeds the limit for Gas group IIC specified in §10.7 of EN60079-11:2012.

- ▶ The user must ensure that the ultrasonic transducers are adequately protected from hazards caused by impacts.



WARNING: Explosion hazard

- ▶ The ultrasonic transducers may only be disconnected and connected by Endress+Hauser Service when under voltage, when this is specified by the device identification. The identification must contain as a minimum the specification [ia Ga] whereby this is applicable only for the danger area concerned as well as the specified ignition group.
- ▶ Safe separation among themselves and from other non-intrinsically safe power circuits must always be ensured so as not to endanger the intrinsic safety. An uncontrolled movement of the disconnected transducer cable should therefore be prevented.

Operation of ultrasonic sensors in Zone 0

The ultrasonic sensors are suitable for operation in Zone 0 at atmospheric conditions, i.e. ambient temperature -20 °C to 60 °C and ambient pressure 0.8 bar to 1.1 bar(a). Using ultrasonic sensors with enclosures made of titanium is only allowed in Zone 0 when it is ensured that solid parts transported by the medium (dust, other particles) could not create ignition hazards through impacts or friction. Otherwise, sensors made of stainless steel must be used.

After installation and following every de-installation and re-installation of the ultrasonic sensors, the seal effect must be appropriately checked. During operation, the leak-tightness must be periodically checked and the seals replaced if necessary. After de-installation and before every re-installation the seals must be replaced according to the original assembly. Seals can be ordered from Endress+Hauser (part number and serial number from type plate at SPU).



NOTICE:

The rise in the ambient temperature outside the pipeline due to a hot pipeline must be taken into account.

The user must ensure that the ambient temperature around the electronics housing does not exceed the maximum permitted ambient temperature marked on the type plate of the FLOWSIC300.

General requirements for installation

- The documentation for hazardous area classification (zone classification) according to EN/IEC60079-10 must be available.
- The equipment must be verified as suitable for use in the classified area.
- Additional requirements must be observed for use of sensors in Zone 0 as described above.
- After installation an initial test run of the complete equipment and the plant according to EN/IEC60079-17 must be performed before regular operation is started.

Requirements regarding cabling

- Cables must fulfill the requirements set forth in EN/IEC60079-14.
- Cables that are subject to exceptional thermal, mechanical or chemical stress must be specially protected, e.g. by laying them in conduits.
- Cables that are not installed fire proof must be flame retardant according to IEC 60332-1.
- Cables for Ex e must comply with EN/IEC 60079-14 section 11.
- Observe the clamping range of the cable glands for cable selection.
- Use Ex i II certified cable glands with adequate ingress protection rating as replacement only.
- For intrinsically safe wiring and an ambient temperature range between -20 °C to +60 °C, the existing metal cable glands may be replaced with light-blue plastic cable glands (available on request).
- Replace the existing cable glands with suitable cable glands if installation with armored cables is intended.
- When delivered, the cable glands are secured by default with a sealing plug. If the cable glands are not used, only sealing plugs with EX e II approval must be used.
- Conduit systems must comply with EN/IEC 60079-14, section 9.4 and 10.5. In addition, compliance with national and other relevant regulations is required
- "Conduits" according to IEC 60614-2-1 and IEC60614-2-5 are not suitable.
- Conduits must be protected against vibration.
- Use a suitable thread sealant, as detailed in EN/IEC60079-14, section 9.4.
- Protect stranded wires against fraying with ferrules.
- Keep clearance and creepage distances for the connected wires in accordance with EN/IEC60079 and EN/IEC 60079-11 respectively.
- Connect unused wires to ground or safeguard so that a short circuit with other conductive parts is excluded.
- Carry out potential equalization in accordance with EN/IEC6079-14
- The meter body and the electronics housing must be connected to the potential equalization.
- Where the FLOWSIC300 is installed in a grounded metal duct, no additional grounding is required for the meter body. The electronics housing must nevertheless be separately grounded.

Connection of the FLOWSIC300 with associated equipment

The terminal compartment of the FLOWSIC300 complies with the requirements of EN/IEC60079-7 or EN/IEC 60079-11.

The FLOWSIC300 provides non-intrinsically safe wiring as well as intrinsically safe wiring with the interconnected associated equipment in the following manner:

- 1 Power supply connection and all other field connections as non-intrinsically safe wiring
- 2 Power supply connection and all other field connection as intrinsically safe wiring to Exi certified equipment in a Zone 1 or Zone 2 classified hazardous area or to [Exi] certified associated equipment in the safe area.
- 3 Power supply connection as non-intrinsically safe wiring and all other field connection as intrinsically safe wiring.

A combination of intrinsically safe and non-intrinsically safe wiring for the field connections is not permitted.

Maximum voltage in the safe area must not exceed 253 V ($U_m = 253V$).

For intrinsically safe wiring:

- The safety-relevant data in the EU Type Examination Certificate and the IECEx Certificate must be observed.
- Intrinsic safety for each circuit must be assessed in accordance with EN/IEC60079-14 section 16.
- The safety-relevant parameters of interconnected equipment must comply with the following values: $U_o < U_i$, $I_o < I_i$, $P_o < P_i$, $C_i + C_{cable} < C_o$, $L_i + L_{cable} < L_o$

The interconnection of two or more intrinsically safe outputs may require an additional assessment of intrinsic safety in accordance with EN /IEC60079-11.

Ensure that the cover on the power supply connection is properly sealed for regular operation. For intrinsically safe wiring, the rear screw cap can be removed and connecting and disconnecting is permitted while the circuits are live and as long as the safe separation between the circuits has been kept.



WARNING: Explosion hazard

- Do not open the enclosure while energized.
- Wait 10 minutes after power has been removed before opening the window cover.
- Do not open the cover of the terminal compartment while energized unless wiring is intrinsically safe.
- Do not remove the cover of the power supply while energized unless wiring is intrinsically safe.
- Do not connect or disconnect while circuits are live unless the area is known to be non-hazardous or wiring is intrinsically safe.
- Do not use the equipment if damaged (includes cables or terminals).

Information on safe operation in hazardous areas**WARNING:**

Always observe the temperature specifications for use in hazardous areas.



Approval of the ultrasonic sensors in Zone 0 is only valid for operation under atmospheric conditions.

- Ambient temperature range is from -40°C to $+60^{\circ}\text{C}$.
- If terminals are assigned with intrinsically safe power circuits, it is recommended that the metal cable glands be replaced with the light-blue plastic ones

**NOTICE:**

The lower ambient temperature is limited to -20°C when using the light blue plastic cable glands. Please observe manufacturers specification.

- The type of protection for the field connections and power supply connection is determined by the external circuits that are connected (\rightarrow p. 118 „Connection of the FLOWSIC300 with associated equipment“).
- Safety-relevant data for intrinsically safe power circuits is provided in the EU Type Examination Certificate and the IECEx Certificate.
- Ensure the cover on the power supply connection is properly sealed. In intrinsically safe installations, the terminal compartment can be opened and cables connected and disconnected while the system is live. In this case the safe separation of the circuits from each other must be observed.
- When heat insulation measures are taken, the SPU of the FLOWSIC300 may not be insulated as well.
- The maximum piezo-electric energy released by impact on the ultrasonic transducers exceeds the limit for Gas Group IIB and IIC. The ultrasonic transducers must be protected against impact.
- Special conditions for use in zone 0: “The devices complying with this standard are intended for use in hazardous areas in which explosive atmospheres exist under normal atmospheric conditions of temperature -20°C to $+60^{\circ}\text{C}$, pressure 80 kPa (0.8 bar) to 110 kPa (1.1 bar), and air with normal oxygen content, typically 21 % v/v. The application of electrical equipment in atmospheric conditions outside this range requires special consideration and may require additional assessment and testing.”
- For the whole area of erection of the apparatus potential equalisation have to be ensured. The protective earth conductor terminals of the apparatus shall be connected to the potential equalisation.
- The combination of intrinsically safe circuits and non-intrinsically safe circuits for the field connections are not allowed.
- The joints of the apparatus exceed the safety level which is defined in table 2 of the EN 60079-1:2014.

**WARNING: Explosion Hazard**

The ultrasonic probes are preferably made from titanium.

- ▶ Should zone 0 or zone 1 have been defined in the pipeline, operation is allowed only when ignition hazards caused by impact or friction can be excluded.



WARNING: Ignition hazard through electrostatic discharge

Ignition hazards through electrostatic discharges can exist when gas flow meters with special paint and a layer thickness >0.2 mm are used in applications with ignition group IIC in accordance with ATEX and IECEx.

- ▶ For installation, the risk of electrostatic charging of the surface must be reduced to a minimum.
- ▶ Use appropriate caution when performing maintenance and cleaning work. For example, the surfaces should only be cleaned with a damp cloth.
- ▶ A warning sign fitted at the factory identifies this type of device:



Safety relevant input and output data

	Ignition protection type intrinsically safe Ex ia/ib IIA/IIB/ IIC								Non-intrinsically safe
Power supply	$U_i = 20 \text{ V}$, $P_i = 2,6 \text{ W}$								12 ... 24 V DC
Current output Terminals 31/32	$U_o = 22.1 \text{ V}$								$U_B = 18 \text{ V}$ $U_B = 35 \text{ mA}$
	I_o [mA]	P_o [mW]	Ex ia/ib IIA C_o [nF] L_o [mH]		Ex ia/ib IIB C_o [nF] L_o [mH]		Ex ia/ib IIC C_o [nF] L_o [mH]		
Hardware variants	87	481	2	7	0,5	4	77	1	
	Characteristic curve: Linear or with the following maximum values for connection to certified intrinsically safe power circuits: $U_i = 30 \text{ V}$ $I_i = 100 \text{ mA}$ $P_i = 750 \text{ mW}$ Effective internal capacity: $C_i = 4 \text{ nF}$ Effective internal inductance: Negligible								
Digital output Terminals 51/52 Terminals 41/42 Terminals 81/82	For connection to certified intrinsically safe power circuits with the following maximum values: $U_i = 30 \text{ V}$ $I_i = 100 \text{ mA}$ $P_i = 750 \text{ mW}$ Effective internal capacity: $C_i = 4 \text{ nF}$ Effective internal inductance: Negligible								$U_B = 30 \text{ V}$ $I_B = 100 \text{ mA}$
RS485 Terminals 33/34	Characteristic curve: Linear $U_o = 5.88 \text{ V}$ $I_o = 313 \text{ mA}$ $P_o = 460 \text{ mW}$ $C_o = 1000 \mu\text{F}$ for IIA resp. $43 \mu\text{F}$ for IIC $L_o = 1.5\text{mH}$ for IIA resp. 0.2 mH for IIC or with the following maximum values for connection to certified intrinsically safe power circuits: $U_i = 10 \text{ V}$ $I_i = 275 \text{ mA}$ $P_i = 1420 \text{ mW}$ Effective internal capacity: $C_i = 4 \text{ nF}$ Effective internal inductance: Negligible								$U_B = 5\text{V}$ $I_B = 175 \text{ mA}$
Ultrasonic sensor connections (for connecting Endress+Hauser ultrasonic sensors only)	Ex ia/ib IIA		Ex ia/ib IIB			Ex ia/ib IIC			
	Characteristic curve: Linear Max. transmission voltage: $U_o = \pm 60.8 \text{ V}$ Short-circuit current: $I_o = \pm 92 \text{ mA}$ $P_o = 1399 \text{ mW}$ Effective internal capacity $C_i = \text{v.k.}$ (negligible) Effective internal inductance: $L_i = 20.6 \text{ mH}$		$U_o = \pm 51.2 \text{ V}$ $I_o = \pm 77 \text{ mA}$ $P_o = 556 \text{ mW}$ negligible $L_i = 15.5 \text{ mH}$			$U_o = \pm 38.9 \text{ V}$ $I_o = \pm 59 \text{ mA}$ $P_o = 556 \text{ mW}$ negligible $L_i = 6.7 \text{ mH}$			

	<p>WARNING: Maximum voltage in the safe area must not exceed 253 V.</p>
---	--

FLOWSIC300

8 Initial start-up

General information

Connecting to a PC

Connecting to MEPAFLOW600 CBM

Identification

Functional check

8.1

Information on initial start-up**General information**

- ▶ The FLOWSIC300 is a measuring system which is normally fitted to a pipeline during installation. When delivered, the FLOWSIC300 has been preconfigured according to the information concerning the measuring location and has passed all tests for ensuring measuring precision and quality in the factory.
- ▶ The individual device settings resulting from the quality assurance tests as well as application-specific data are saved in non-volatile memory of the FLOWSIC300 and should not be changed during start-up.
- ▶ The geometric path parameters of path length and path angle must be determined during installation and entered in MEPAFLOW600 during start-up.
- ▶ As an option, the FLOWSIC300 can be pre-installed in a pipe section. In this case, the geometric path parameters are determined very exactly in the factory during 3D measurement and parameterized in the device. Changing the parameters is not required in this case.

**NOTICE:**

If no nominal pipe diameter is known during production of the FLOWSIC300 (e.g. FLOWSIC300 without optional sensor), the device is preconfigured in the factory for nominal pipe diameter 24".

In any case, the geometric parameters (inner pipe diameter, path length, path angle) must be determined during commissioning and parameterized in the device.



If the FLOWSIC300 is to be used at a different measuring location to the one specified in your order, please contact your regional sales organization. It may be necessary to adapt various device parameters in this case.

Preparations for initial start-up

- ▶ Complete all mechanical and electrical installation work before start-up.
- ▶ Provide a PC with MEPAFLOW600 CBM installed (→ p. 126, §8.2).

Work sequence during initial start-up

- 1 Connect FLOWSIC300 and MEPAFLOW-PC (→ p. 126, §8.2).
- 2 Start the MEPAFLOW600 CBM program and connect to the FLOWSIC300 (→ p. 128, §8.3).
- 3 Carry out the start-up procedure (→ p. 134, §8.5).
- 4 Carry out a functional check (→ p. 148, §8.6).



The start-up procedure essentially comprises:

- ▶ Entering individual plant parameters (e.g. active measuring path installation angle).
- ▶ Setting desired output variables and reaction times.
- ▶ *As required:* Configuring additional functions (e.g. data storage, graphic display).



Settings can be protected with a password.

Adjustment/calibration

- A zero point adjustment is not required.
- Velocity measurement calibration is only required when the velocity profile on the measuring axis of the ultrasonic sensors is not representative for the overall cross-section of the pipeline. – Reference measurements with a reference measuring system are required for calibration. The correction data (regression coefficients) determined are entered manually.

Individual optimization

If measurements in certain operating states of the pipeline are not satisfactory (e.g. because measuring conditions are temporarily outside the specified technical data for the measuring system), the measurements could possibly be improved by setting device-internal parameters to special, individually optimized values. The options are described in the Service Manual.



NOTICE:

The manufacturer assumes no liability for incorrect settings.

- ▶ Only allow Endress+Hauser Service, or persons especially trained for this purpose, to make individually optimized settings.

8.2 Connecting to a PC

The FLOWSIC300 has an RS485 serial interface. An interface adapter serves to connect to a computer.

8.2.1 Connecting to a serial interface (RS232/COM)

Prerequisites

- RS485/RS232 cable
- RS232 interface cable "1:1" (pin 2 – pin 2 and pin 3 – pin 3) (→ Fig. 44).
- RS485/RS232 adapter
 - ▶ Use an adapter that can automatically differentiate between send and receive modes.
 - ▶ *To create a connection in a potentially explosive atmosphere: Use an isolating repeater as adapter.*



MEPAFLOW600 CBM does not support RTS/CTS data transfers. Therefore the RS485/RS232 adapter must be able to toggle automatically itself.

Wiring example

Fig. 44

Wiring example for "MEPA interface set RS485/RS232 intrinsically safe"

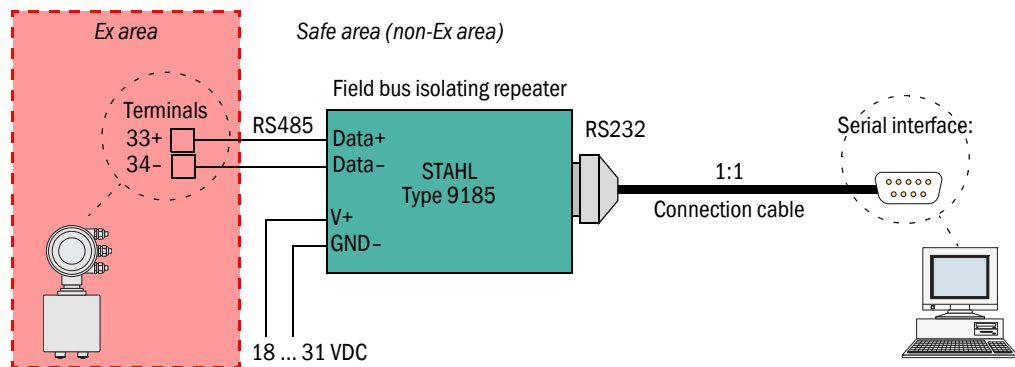

8.2.2 **Connecting to a USB port**

Prerequisites

- PC with USB interface
- RS485/USB converter
- Software driver of the USB converter

+i The USB interface set includes a CD-ROM with a software driver for the USB converter. The drive must be installed in order to be able to create an interface connection between FLOW SIC300 and MEPAFLOW600 CBM.

Wiring example

! ▶ Install the software driver of the USB converter on the PC.

Fig. 45 Wiring example for “MEPA interface set RS485/USB” (converter, cable, plug, CD-ROM with software driver), non-intrinsically safe

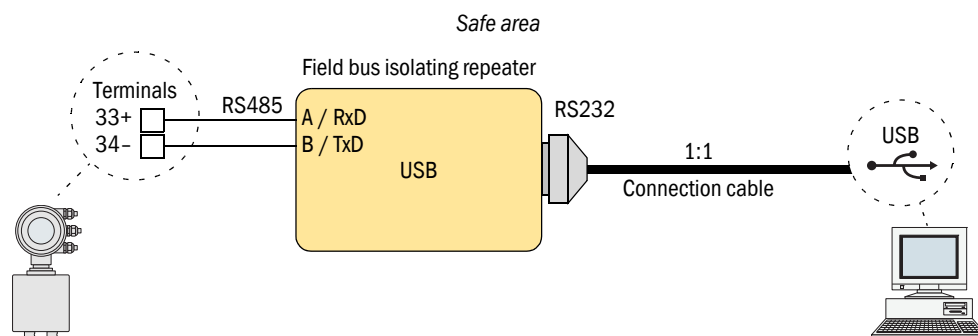

8.3 Connecting to MEPAFLOW600 CBM

8.3.1 Starting MEPAFLOW600 CBM

The MEPAFLOW600 CBM program is on the product CD delivered with the device. See → p. 46, 2.11.1 for further details on installation.

- ▶ After completing installation, start the MEPAFLOW600 CBM program by selecting the entry “MEPAFLOW600 CBM” in the program group created during installation or by double-clicking the desktop icon.

Fig. 46 MEPAFLOW600 CBM program group and desktop icon

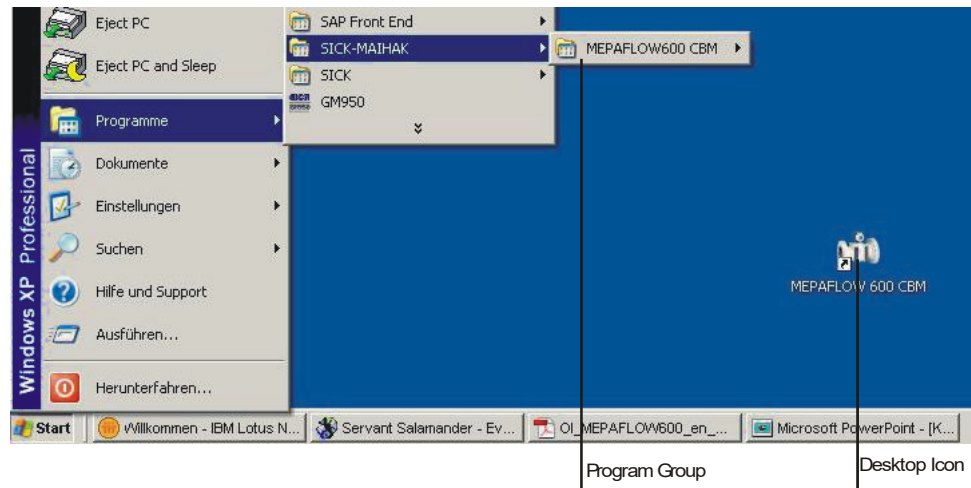

8.3.2 **Choosing a user access level**

- ▶ Page “Connect/Disconnect to meter” is displayed with the password dialog window when MEPAFLOW600 CBM is started. (→ Fig. 47)
- ▶ Select a user level by activating the corresponding radio button, enter the password and click “OK”.

User access level	Password
Operator	No password required
Authorized operator	“sickoptic”
Service	“expert”



User level “Service” is mandatory for initial start-up.

Fig. 47 MEPAFLOW600 CBM, page “Connect/Disconnect” with password dialog window

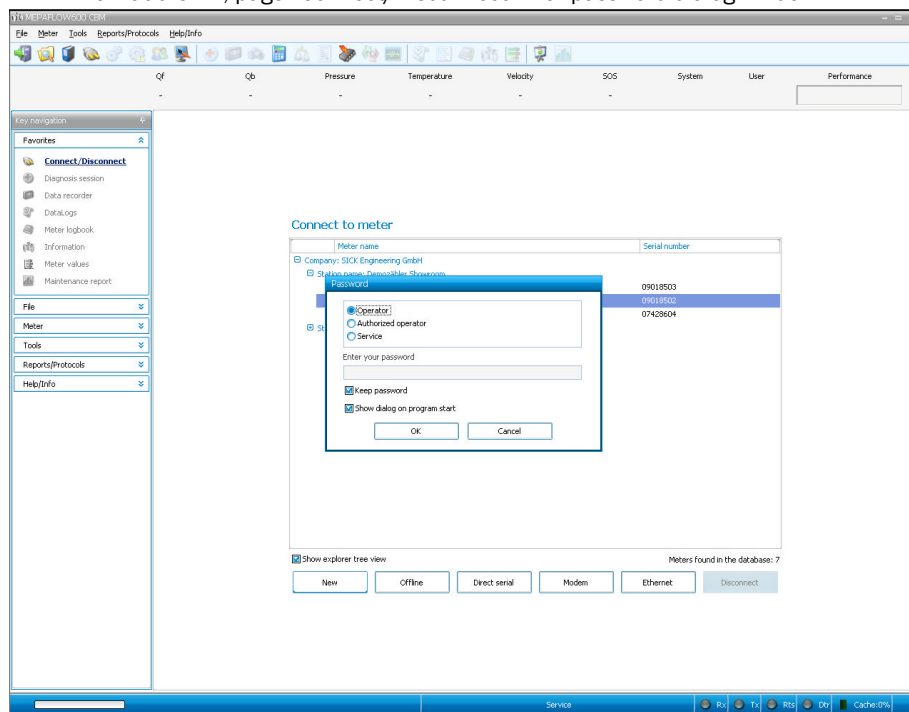

- ▶ The password dialog window fades and the “Connect/Disconnect” page appears with a list of all devices in the Device database.

8.3.3 **Creating a new device entry in the Device database**

New device entries can be made whether the respective device is connected to the PC or not. If the device is connected, MEPAFLOW600 CBM loads all the available parameters from the device. If the device is not connected, an initial master data record is created with the data entered by the user.

- ▶ Click “New” to create a new device entry in the Device database. Then follow the instructions on the screen.

8.3.4

Online connection: Connect

- ▶ Select a device and click “Connect” to establish a serial connection to a device connected to the PC.
- ▶ Enter the respective connection settings in the Connection settings window (→ Fig. 48) and click “Connect” to establish an online connection to the device. If the connection fails, see → p. 171, 10.4 for troubleshooting.

Fig. 48

Connection settings

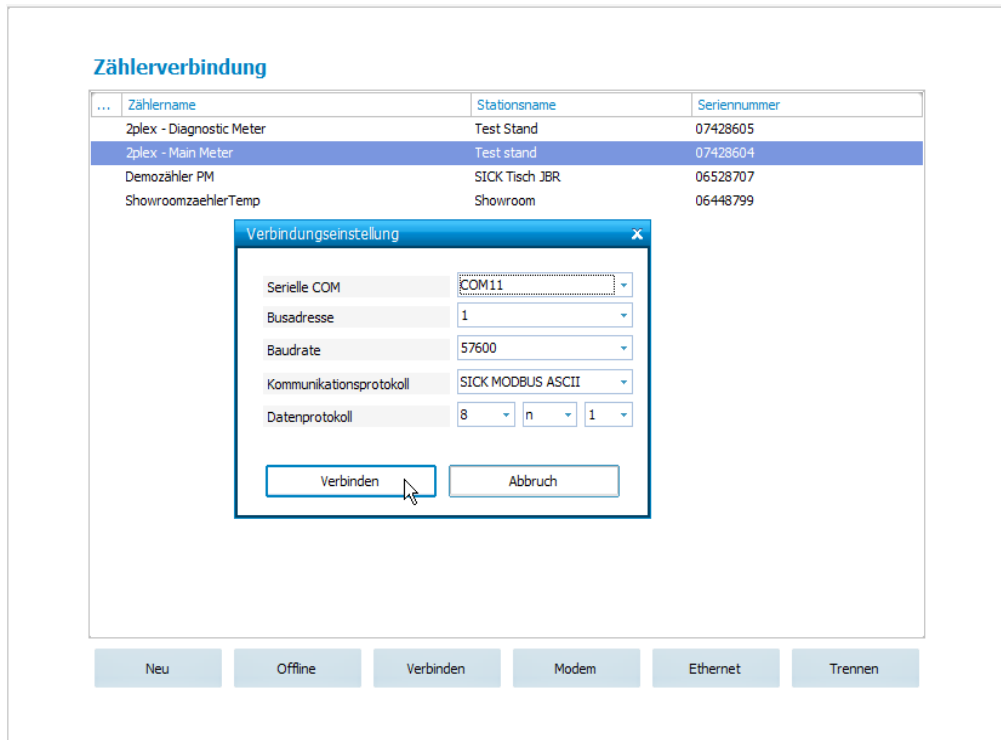

Parameters shown in → Fig. 48 are standard values - apart from the serial port that requires individual configuration.

- ▶ After the connection has been established, MEPAFLOW600 CBM displays the start page (can be specified in the program settings) and the current device states.

8.3.5

Online Connection: Ethernet

The FLOWSIC300 can be connected to a network via Ethernet using a suitable adapter. This adapter converts the communication between device and MODBUS (ASCII or RTU) to MODBUS TCP. MEPAFLOW600 CBM supports the MODBUS TCP protocol.

+i **Requirements**

- Firmware V3.3.05 or higher is required for the Ethernet connection. It provides the required generic MODBUS protocol via the interface for the MODBUS TCP adapter.
- The FLOWSIC300 must be connected to a “MODBUS ASCII/ MODBUS RTU to MODBUS TCP” adapter that is connected to a network via Ethernet and has a - preferably permanent - IP address.
- The PC with MEPAFLOW600 CBM V1.0.46 or higher installed must be connected to the network and have uninhibited access to this IP address.

Preparations for online connections via Ethernet

- ▶ Ensure the serial port (terminals 33/34 or 81/82) of the FLOWSIC300 is configured so that generic MODBUS RTU or generic MODBUS ASCII is used (NOT Endress+Hauser MODBUS protocol).
- ▶ Connect a MODBUS RTU/MODBUS ASCII to MODBUS TCP adapter to the serial port according to the manual of the adapter.
- ▶ Connect the adapter cable to your network.
- ▶ Make sure the network assigns a permanent IP address to the adapter.
- ▶ Configure the adapter to the network settings (IP address / protocol / baudrate / gateway etc.) that you want to use (refer to adapter manual).
- ▶ Make sure the PC with MEPAFLOW600 CBM has access to the adapter’s IP address.
- ▶ Ensure the MODBUS bus address of the device is known.
- ▶ In case of problems with the network setup, refer to your network administrator.

- ▶ Select a device and click “Ethernet” to establish an online connection to the device.
- ▶ Enter the IP address of the MODBUS TCP adapter and the bus address of the device in the “MODBUS TCP - MODBUS RTU/ASCII gateway settings” dialog window (→ Fig. 48).
- ▶ Click “OK” to establish an online connection to the device.

Fig. 49

Dialog window “MODBUS TCP - MODBUS RTU/ASCII gateway settings” for online connections via

Ethernet

Zählerverbindung

Zählername	Stationsname	Seriennummer
Zplex - Diagnostic Meter	Test Stand	07428605
Zplex - Main Meter	Test stand	07428604
Demozähler PM	SICK Tisch JBR	06528707
Main Station Demo	Main Station	10845266
		06448799

MODBUS TCP - MODBUS RTU/ASCII Gateway Einstellungen

Verbindung via Ethernet nur möglich zu Zählern mit Firmware V3.3.05 oder höher und Unterstützung eines generischen MODBUS Protokolls auf der Schnittstelle zum MODBUS TCP Adapter.

Ethernet-Parameter

IP - Adresse: 10 . 133 . 87 . 159

Portnummer: 502

Verbindungs Timeout (sec): 60

Busadresse: 1

OK Abbrechen

Neu Offline Verbinden Modem Ethernet Trennen



Tested "MODBUS TCP to MODBUS ASCII/RTU Adapter"

The connection between FLOWSIC300 and MEPAFLOW600 CBM was tested with the "MODBUS TCP to MODBUS ASCII/RTU Converter", model MES1b from B&B Electronics. This adapter is delivered with a program that searches the network for connectable devices and provides the user with the corresponding IP addresses.

8.4

Identification

Before start-up, cross-check the data representing the flow meter with the data in the test protocols contained in the Manufacturer Data Report (MDR). This can be done on the LCD display (see “Technical Information”) or - much easier - with the MEPAFLOW600 CBM program.

Comparing the data with MEPAFLOW600 CBM:

- ▶ Open the page “Meter information” and compare the data in Section “Identification” (→ Fig. 50) with the data in the MDER Test reports or, if the device has been calibrated, with the Calibration report and Parameter report.

Fig. 50

Page “Meter information”

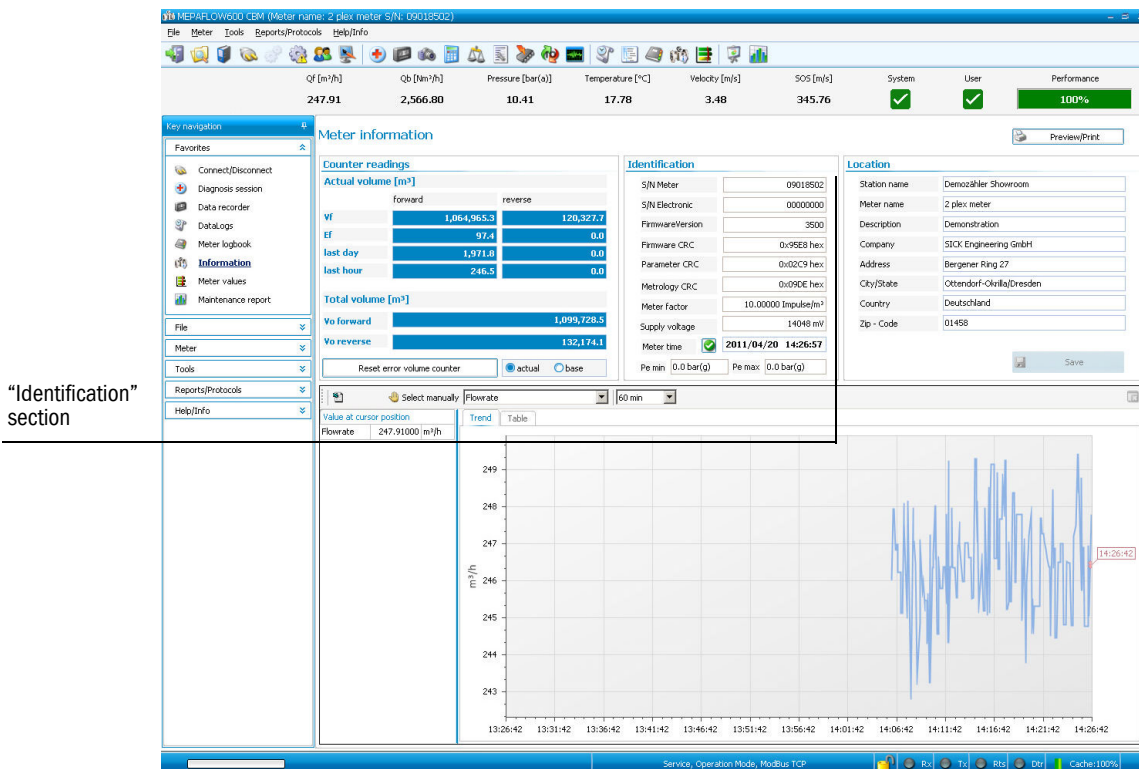

“Identification” section

Firmware

The FLOW SIC300 firmware is stored in non-volatile memory (FLASH PROM). Program codes of the signal processor and the system microcontroller are identified with a common valid version number (register #5002) and checksums (register #5005) and can be verified as described above.

8.5 Start-up

8.5.1 Entering the installation parameters

- ▶ If not already done in menu item “Password”, activate Service access and enter the Service password → p. 129, §8.3.2.
- ▶ Switch to directory “Device parameters / Meter body”.
- ▶ Enter the values determined for the installation angle in §4.2.4 (→ p. 69) as radian measure (rad):
 - Register #7101 - Angle1: β_1
 - Register #7102 - Angle2: β_2 (only for 2-path configuration)



The geometry tool outputs the installation angle in degrees (°).

$$\beta \text{ (rad)} = \beta \text{ (}^\circ\text{)} \times \frac{\pi}{180}$$

- ▶ Enter the path length determined in §4.2.4 (→ p. 69).
 - Register #7105 - Length1: L
 - Register #7106 - Length2: L (only for 2-path configuration)
- ▶ Check the settings of inner diameter (register #7100 - InnerDiameter) and pipe diameter (register #7119 - PipeDiameter) and adapt these exactly to the local situation.
 - Inner diameter: Diameter at measuring location
 - Pipe diameter: Diameter of pipeline



The pipe diameter is preconfigured according to the nominal pipe width which was specified during the order process.

- ▶ Adapt the settings to the actual pipe diameter at the measuring location to ensure representative measuring results.

Inner diameter and pipe diameter are normally equal. When the pipe diameter differs from the inner diameter at the measuring location (e.g. when a narrower pipe piece is used), enter the correct values accordingly.

Fig. 51

Device parameters / Meter body

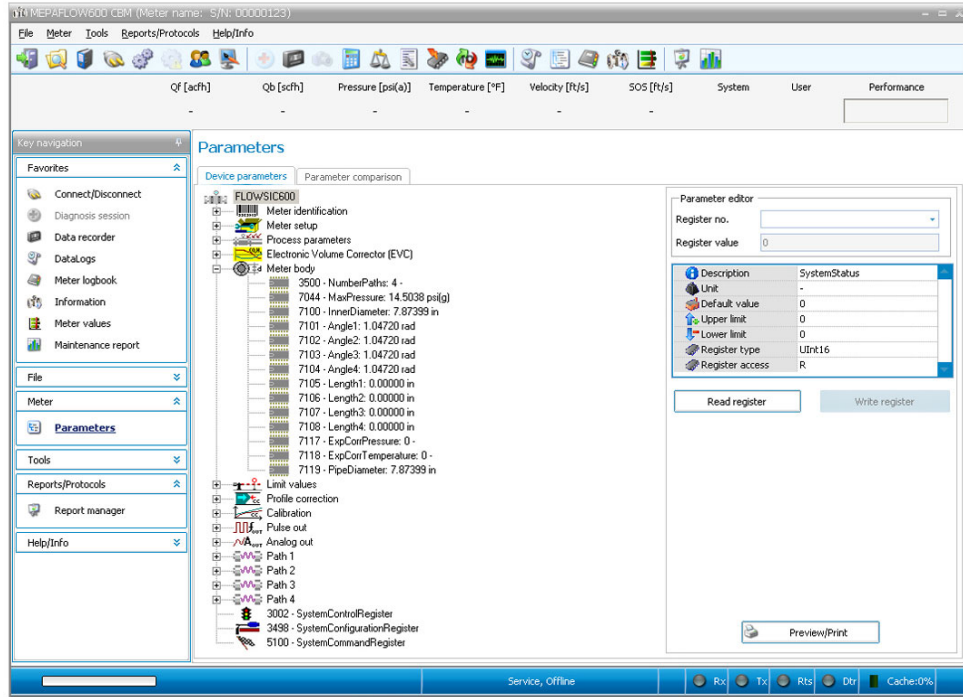

8.5.2 Field setup wizard

The Field setup wizard of the MEPAFLOW600 CBM program guides the user through the parameter configuration during FLOWIC300 start-up. The wizard consists of 8 pages. Information on checking and configuring can be found in the FLOWIC300 “Instrument Data Sheet” contained in the device documentation (Manufacturer Data Record, MDR) (see → Fig. 52 for an example).

 User level “Service” is required to change parameters using the Field setup wizard.

- ▶ Select “Tools / Field setup wizard” in the menu to start the wizard.
- ▶ Follow the instructions on screen step by step.

Fig. 52 Example of an “Instrument Data Sheet” as contained in MDR

INSTRUMENT DATA SHEET FOR : ULTRASONIC GAS FLOW METER					
0	Typecode	FL600-4P3D06P#01000147.0B22N-S2-3DC1N1Y			
1	GENERAL		TRANSMITTER (Integral)		
2	Meter-No.: 3889	55*	Power supply / Power consumption	12 ... 28,8 V DC	< 1W
3	Type	FL600	57*	Enclosure classification	IP 67
4	Meter size	06" / DN150	58*	Cable entry	M20 x 1,5 (3x)
5*	Article number		59*	Hazardous Area Class.	
6*	TAG number		II 1/2G Eex de b [a] IIA T4		
7*					
8*	Order number	01/11-2	60	SPU housing material	Aluminium
9	METER BODY		61	Ambient temperature (range)	°C -40 ... 60
10	Inner pipe diameter	mm 147,00	62	Display	LCD
11	Overall length (A)	mm 450,00	63	Display language	Russian
12	Overall height (B)	mm 490,00	64	Engineering units	Metric
13	Weight	kg 130	65	Output and Signal Configuration - Signal processing unit	
14	Flow range	m³/h 32 ... 2500	66	DO2/AC0 Terminals 31/32 (HF-Pulse)	Volume s.c., no pulses when data invalid
15	Number of meas. paths	4	67	Signal configuration	NAMUR / normally open
16	Linearity	+/- 0.5% of MV 0.1 ... 1 Qmax	68		
17*	Repeatability	< 0.1%	69		
18	Flange design code	DIN/EN 1092-1	70		
19	Flange class	PN100	71		
20	Flange face	Form B2	72	MOD Terminals 33/34 (RS 485)	SICK Modbus ASCII
21	Body material	1.0566 / ASTM A350 Gr. LP2	73	DO1 Terminals 51/52 (HF-Pulse)	Volume s.c.
22	Transducers exchangeable under pressure	No	74	meter factor	1/m³ 2.880
23*	Transducer cover	Aluminium	75	Signal configuration	NAMUR / normally open
*24	Design temperature	°C -46 ... 100	76	max. Output	8.2 V / 0,8...6,5 mA
*25	Design pressure	bar (g) 94	77	DO2 Terminals 41/42 (Status)	Status Warning
26	Material certificate	3.1 EN 10204	78	Signal configuration	NAMUR / normally open
27*	Enclosure classification	IP 67	79	max. Output	8.2 V / 0,8...6,5 mA
28*	Surface coating / painting	two layers: Epoxy + Acrylic RAL9002	80	DO3 Terminals 81/82 (RS 485)	SICK Modbus ASCII
29*	Pressure tapping	1/4" NPT female	81		
30	Sensors		82		
31			83	COMMUNICATION	
32*	Sensor material	Titan 3.7165	84	Interface	2x RS 485
33			85	Protocol	SICK Modbus ASCII
34			86		
35	Supplementary information: Process and operating conditions				87
36					88
37		min.	norm.	max.	89
38	Flow rates	m³/h 32	-	2.500	90
39	Pressure	bar (g) 10,0	12,0	13,5	91
40	Temperature	°C 3	-	25	92
41					93
42	Medium	natural gas - dry			94
43	Aggressive contents	No agents			95
44	Liquid content	g/cm³ 0			96
45					97
46	Dry calibrated				98
47					98
48					100
49					101
50					102
51					103
52	National type approval				104
53					105
	REMARKS				106
Lines marked by * are default values					
Lines marked by ** are safety relevant features according to 97/23/EC					
This data sheet has been created based on the technical details provided with the order 01/11-2. Missing information has been completed by SICK and marked with a *.					
Manufacturing period after receipt of approval for this data sheet, is _____ weeks.					
Subsequent changes will require approval by SICK. Effects on date of despatch are the responsibility of the client. Any additional cost involved will be charged.					
Engineered By		Thomas Burkhardt		Date	14.02.2011
Customer / Project		Ukrtransgas-Budmontazhgas		Revision	1

8.5.3 **Location information and unit system (Field setup page 1 of 8)**

These data serve to identify a device in the MEPAFLOW600 CBM Device database.

Fig. 53 Field setup wizard, page 1 of 8: Location information

The screenshot shows a software window titled "Field setup" with a sidebar on the left and a main content area on the right. The sidebar contains a "Key navigation" menu with options: Favorites, File, Meter, Tools, Reports/Protocols, and Help/Info. The "Tools" menu is expanded, showing options: Save cache, SOS Calculator, Meter calibration, **Field setup** (highlighted), Firmware update, I/O-Check, and Path diagnosis. The main content area is titled "Location" and contains the text "Input of measuring site data." followed by several input fields:

Company	SICK Engineering GmbH
Address	Bergener Ring 27
City/State	Ottendorf-Okrilla/Dresden
Country	Deutschland
Zip code	01458
Station name	Demozähler Showroom
Meter name	2 plex meter
Description	Demonstration

At the bottom of the window, there is a status bar showing "Step 1/8" and a set of navigation buttons: Cancel, Back, Next, and Close.

8.5.4 **Application data (Field setup wizard, page 2 of 8)**

The pressure and temperature values to be entered on this page are stored as parameters PressureFix and TemperatureFix.

Fig. 54 Field setup wizard, page 2 of 8: Application data

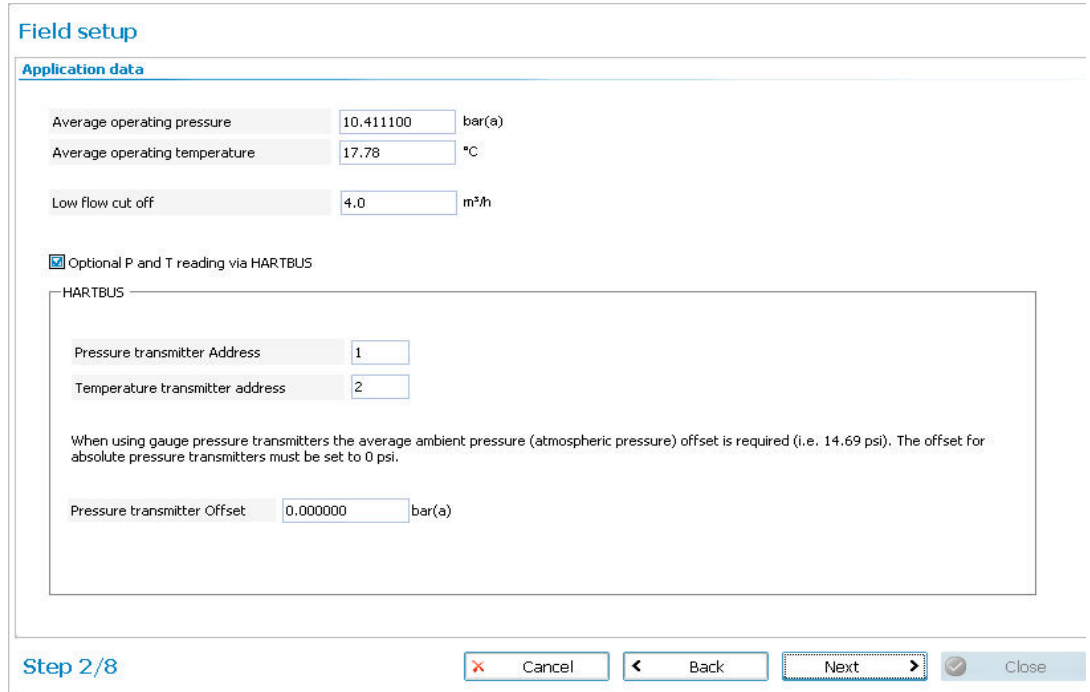

These values are used when the FLOWSIC300 with integrated volume corrector works using constant volume temperature and pressure correction.

The “Low flow cut off” is usually set to 25% of Qmin.

+i **Option HART®**
When the option HART® protocol was ordered, checkbox “Optional P and T reading via HARTBUS” can be activated. In this case, the FLOWSIC300 works with HART® communication in Master mode.

8.5.5 **Integrated electronic volume corrector (EVC) (Field setup wizard, page 3 of 8)**

+i **EVC option**
When the device was ordered with the “Integrated electronic volume corrector (EVC)” option, the integrated electronic volume corrector must be activated in accordance with the description in “Technical Bulletin: Electronic Volume Correction (EVC)”

Only the necessary EVC parameters for the GERG88 correction algorithm are available in the Field setup wizard.

Fig. 55 Field setup page 3 of 8: Integrated electronic volume corrector

Field setup

Integrated electronic volume corrector

The compressibility calculation is based on SGERG 88 (gross method). The following averaged gas characteristics are required:

Heating value	11.10000	kWh/m ³
Mass density at base	0.70000	kg/m ³
CO2	1.00000	Mol%
H2	0.00100	Mol%

Step 3/8

8.5.6 **I/O configuration – output configurations (Field setup wizard, page 4 of 8)**

The output configuration has to be set based on the information provided in the Instrument Data Sheet.

Fig. 56 Field setup wizard, page 4 of 8: I / O configuration

Field setup

I/O configuration

The configuration of the meter's output signals can be setup on the following table. For each terminal pair (i.e. 31/32) or digital output (i.e. DO 0, DO 1 etc.) assign the appropriate signal type (according to the Instrument Data Sheet).

DO 0:	Terminals 31/32	Analog/HART
R5 485:	Terminals 33/34	Serial interface ▾
DO 1:	Terminals 51/52	Pulse ▾
DO 2:	Terminals 41/42	Status ▾
DO 3:	Terminals 81/82	Serial interface ▾

Step 4/8

8.5.7 I/O configuration – terminal assignment (Field setup wizard, page 5 of 8)

The terminal assignment contains five tabs for the individual terminals and one for the overview. The outputs can be specifically configured in these tabs. Use the information buttons (when displayed) for detailed information on the output signal and support functions. Use the built in Meter Factor calculator for the pulse output.

Fig. 57 Field setup page 5 of 8: I / O configuration - Terminal assignment, tab for terminals 31/32

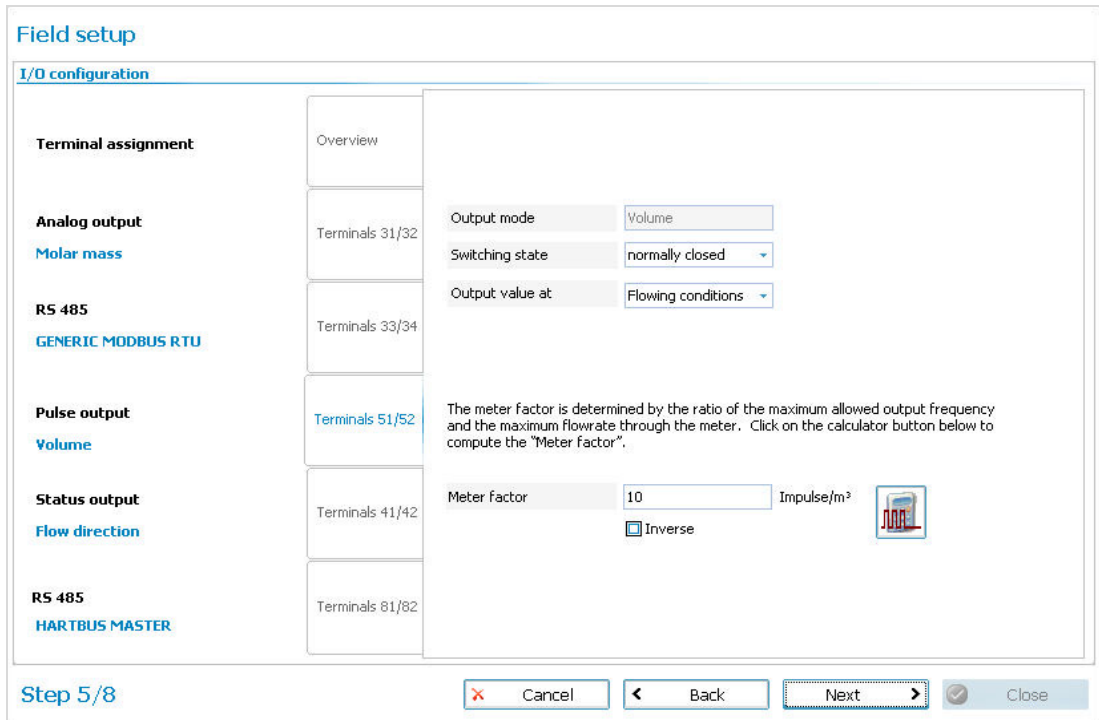

Impulse factor

The meter factor is set at the factory in accordance with customer specifications. If these are not available, the meter factor is set to a standard value so that the maximum pulse output frequency is approx. 2 kHz for maximum throughflow.

The new meter factor can be calculated according to the following formula:

f_{max} : max. pulse frequency [Hz]
 Q_{max} : max. volume flow [m³/h], [ft³/h]

$$\text{Meter factor} = \frac{f_{max} \cdot 3600}{Q_{max}} \left[\frac{\text{Pulse}}{\text{Volume unit}} \right]$$

- In North America “K-Factor” is used. The K-factor is the inversion of the device value and can be set by clicking “Inverse” in “Meter factor calculator”. For assistance in calculating the meter factor, use the integrated “Meter factor calculator” (→ Fig. 58).
- ▶ Click the button “Meter factor calculator” (→ Fig. 57).

Fig. 58

Meter factor calculator

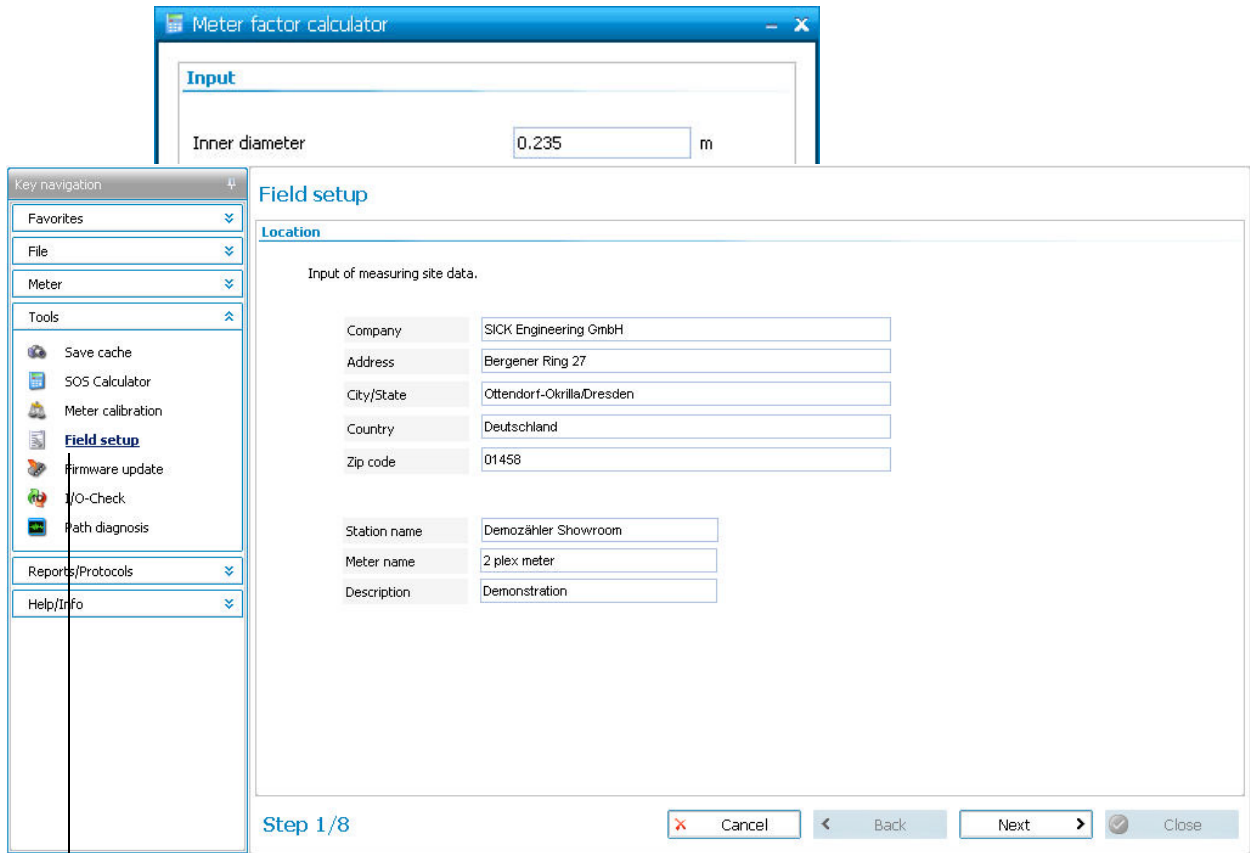

Start Field setup wizard

Warning limits

If a status output has been configured as “Warning” output in step 4 (→ p. 139, 8.5.6), the settings for this output can be displayed by clicking a register for this output.

The user warning limits can be configured and activated after completion of the Field setup wizard (→ p. 134, 8.5).

Fig. 59

Status output configured for “Warning”

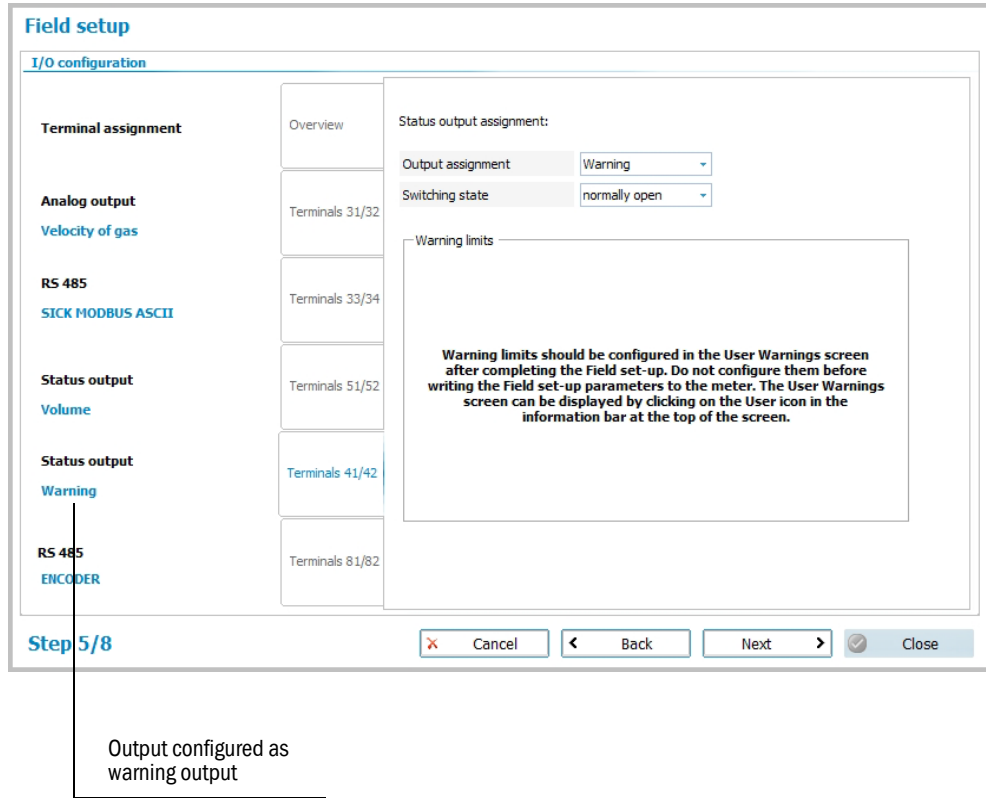

Analog output

The analog output must be configured for adapting the FLOW SIC300 to the various application conditions. Several parameters need to be changed.

Output current I_{out} is calculated as follows:

$$I_{out} = 4 \text{ mA} + \frac{Q - AORangeLow}{(AORangeHigh - AORangeLow)} \cdot 16 \text{ mA}$$

- Q: Actual volume flow rate (other possible sources: normalized volume flow rate, mass flow rate, molar mass)
- AORangeHigh: Upper range limit (has to be set)
- AORangeLow: Lower range limit (has to be set)
- Alarm value: Enter a value outside the usual measuring range (< 4 mA or > 20 mA) which is to be output during a device malfunction. If the alarm value is configured with 0 mA, output of the current measured value continues during a malfunction.

NOTICE:
 In the device configuration with active analog output and use of HART bus communication, an alarm value < 4mA must be configured. When an alarm value > 20 mA is used, HART communication errors could occur.

- 8.5.8 **LCD Display settings (Field setup wizard, page 6 of 8)**
- ▶ Assign the language to be used in the menu of the LCD display.
 - ▶ Choose from the dropdown menu, which measured variables and displays are to be displayed on the two page standard display.

Fig. 60 Field setup wizard, page 6 of 8: LCD display setup with dropdown menu

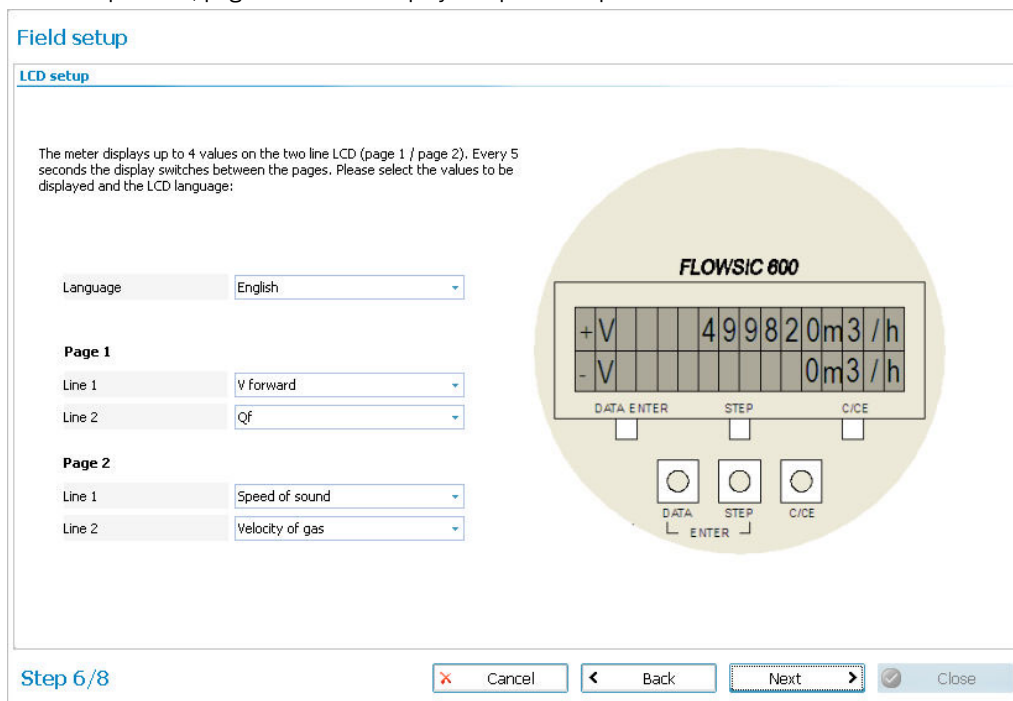



Table 3 Possible sources for lines on LCD

Reg. #	Measured value output	Abbreviation in MEPA- FLOW600 CBM	Abbreviations on LCD
7002	Volume flow rate in standard state [1]	Qb	+/- Qb
7001	Volume flow rate in operating state[1]	Qf	+/- Qf
5010	Volume counter forward[1]	V forward	+ Vf
5012	Volume counter reverse[1]	V reverse	- Vf
5011	Error volume counter forward[1]	E forward	+ Ef
5013	Error volume counter reverse[1]	E reverse	- Ef
7004	Gas velocity	VOG	VOG
7003	Sound velocity	SOS	SOS
7022	Pressure (from external source)	p	p
7021	Temperature (from external source)	T	T
3029	Frequency	FO	FO
7035	Analog output	AO	AO
3020	Input voltage	Uin	Uin
5016	Forward volume total [1]	V forward	+ Vo
5018	Reverse volume total [1]	V reverse	- Vo
5041	Standard volume flow rate forward[1]	Vb forward	+Vb
5043	Standard volume flow rate reverse[1]	Vb reverse	- Vb
5042	Error volume in standard state forward[1]	Eb forward	+ Eb
5044	Error volume in standard state reverse[1]	Eb reverse	- Eb
5045	Total volume, original (plus forward, minus reverse volume)[1]	Vo	Vo
5079	Total mass counter forward[1]	M forward	+ M
5081	Total mass counter reverse[1]	M reverse	- M
7047	Mass flow	M flow	+/- Mf
5085	Total volume in standard state forward[1]	Vo forward	+Vb
5047	Total volume in standard state reverse[1]	Vo reverse	- Vb
7065	Volume flow rate in standard state as m ³ /d	Qb (m ³ /d)	+/- Qb
-	None	Empty row	-

[1] The 18 digit total volume device values are stored in two word registers each with 9 positions. The first 9 digits are stored in the "low" digit register, and the last 9 digits in the "high" digit register. The LCD displays only the "low" bits of the total volume counters.

8.5.9

Configuration update (Field setup wizard, page 7 of 8)

 User access level: "Authorized Operator" or "Service"

- ▶ Set the device to Configuration mode.
- ▶ Use "Write to flow meter" to write the configuration and parameter settings from pages 2 to 6 of the Field setup wizard to the device. The summary field displays information about the actions just carried out (successful or unsuccessful writing of parameters).
- ▶ Use "Reset at flow meter" to reset the error volume counter and the logbooks - recommended after device start-up.
- ▶ The time synchronization function serves to write the PC timestamp to the device and therefore synchronize the device to your local time settings. Be careful with this function. Read → p. 156, 9.5.3 before using it.
- ▶ Set the device back to measuring operation.
- ▶ Print a parameter report to document any changes made.

Fig. 61

Field setup wizard, page 7 of 8: Configuration update

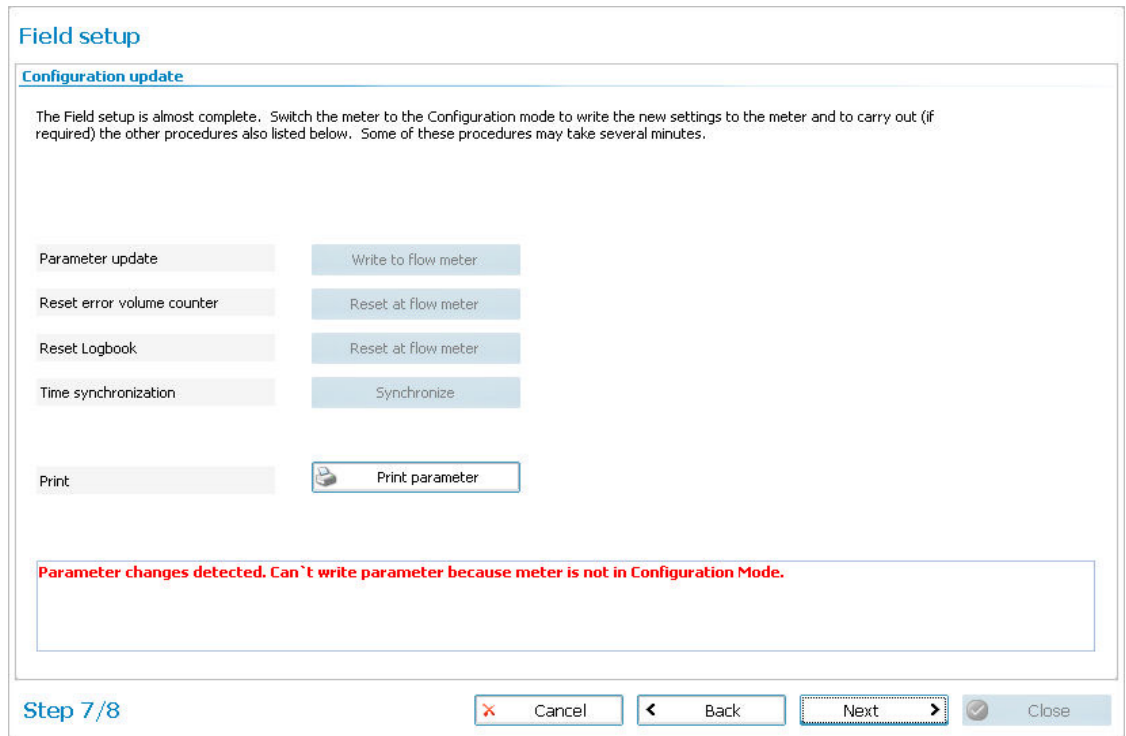

8.5.10 **Maintenance report (Field setup wizard, page 8 of 8)**

Create the Maintenance report.

- ▶ Enter the information (Description, Technician) in the fields provided.
- ▶ Specify the collection duration (e.g. 3 minutes). This is the time in which the current device data are to be recorded to document the device status after the field has been set. (Live data collection starts after clicking “Start”.)
- ▶ Enter the current pressure, temperature and SOS. If the SOS is unknown, use the SOS Calculator to calculate the sound velocity the gas composition. The gas composition must be current and representative (more details → p. 154, 9.5.1).
- ▶ Click “Start” to start live data collection. Diagnosis data, measured values and status information will be collected over the specified time span.
- ▶ Once the data collection has been completed and “Create report” becomes available, click on it. This creates and displays the Maintenance report.
- ▶ Print the Maintenance report and file a copy in the Manufacturer Data Report (MDR) delivered with the device.
- ▶ Close the preview window.
- ▶ Click “Close” in the Field setup wizard

The Field setup wizard is now complete.

Fig. 62 Field setup wizard, page 8 of 8: Maintenance report

The screenshot shows a software window titled "Field setup" with a sub-header "Maintenance report". Below the header, there is a text instruction: "Upon completion of setup, it is suggested that a Maintenance report be created. Enter the applicable data in the available fields below and press the 'Create report' button to generate the report." The form contains several input fields and buttons:

Report name	Maintenance report	Collection duration	10 min
Description	Maintenance report	Mean temperature	17.78 °C
Technician	Torsten Eichner	Mean pressure	10.41 bar(a)
Last log date	4/20/2011	Calculated SOS	m/s SOS Calculator

At the bottom of the form, there are buttons for "Start", "Stop", "Reset", and "Create report". Below the form, there is a "Progress messages" section which is currently empty. At the very bottom of the window, there are navigation buttons: "Step 8/8", "Cancel", "Back", "Next", and "Close".

+i The Maintenance report is stored automatically in the MEPAFLOW600 CBM database after creation. It is accessible via the “Meter explorer” and the “Report manager”. The Maintenance report can also be exported to Excel using the direct link provided when the Maintenance report is displayed.

8.5.11 **Separating the connection to the device and terminating the session**

A session is stored in the MEPAFLOW600 CBM device database when the connection to the device is separated. It contains the following data:

- A complete set of device parameters at the time of separation
- All parameter changes made during Field setup (entries can be viewed in the “Meter Explorer”)
- All logbook data downloaded on page 7 of the Field setup wizard
- The Maintenance report created on page 8 of the Field setup wizard

These data can be retrieved later with the “Meter explorer” even when there is no direct connection to the device.

Proceed as follows to separate the connection to the device and terminate the session:

- ▶ Select “File / Connect / Disconnect” to switch to the “Connect / Disconnect” page.
- ▶ Click “Disconnect”. The “Session description” window opens.
- ▶ Describe the activities carried out during the session (e.g. “Field Setup”).
- ▶ Click “OK”.

8.6 **Functional check**

The major system parameters are configured at the factory. The standard settings should allow FLOWSIC300 operation without errors. However, correct measuring operation should be checked when the measuring system is installed and running under the planned operating conditions.

Recommendation: Carry out a plausibility check on the measured and diagnosis values - even when the device appears to be functioning correctly.

8.6.1 **Checking the operating state on a version with LCD front panel**

State	Display
Normal operating state:	Measured values/current displays, alternating (time interval: approx. 5 seconds).
Current error/current warning:	A message is shown every 2 seconds.
Logbooks contain errors, warnings or information that have not been acknowledged yet:	A code letter blinks in the top right corner of the display. ^[1]
Logbooks contain errors, warnings or information that have been acknowledged:	The code letter is shown permanently. ^[2]

[1] Retrieve the logbook to view detailed information (→ p. 158, 9.7.1). Troubleshooting → p. 163, § 10.

[2] To delete this display: Delete the entries in the logbook.

8.6.2 Function test with MEPAFLOW600 CBM

Checking the device function

- 1 As soon as the plant is running with the start volume flow rates: Call up the “Meter values” page and check the performance.
 - Measurement performance should be at least 75%.
 - Exception: Performance could be considerably lower when the gas velocity is faster than 30 m/s.
- 2 Check the displays in the main system bar (→ Fig. 63):
 - The icons under “System” and “User” must be green.
 - If one of these icons is yellow or red: → p. 164, § 10.1.

Checking the zero phases setting

- ▶ Call up the Path diagnosis wizard and check the “Zero Phase” parameter for each two sensors for each measuring path (paths 1, 2).
Criteria for correct zero phase values (→ Fig. 63):
 - The green cursor is positioned symmetric between both red dashed limit lines.
 - The red star-shaped marking is exactly on the third positive zero crossing of the ultrasonic signal curve.
 - If this is not the case: Adapt the zero phase.

 The correct setting of the zero phases serves as basis for precise run-time measurement of ultrasonic signals.

Fig. 63

Main system bar

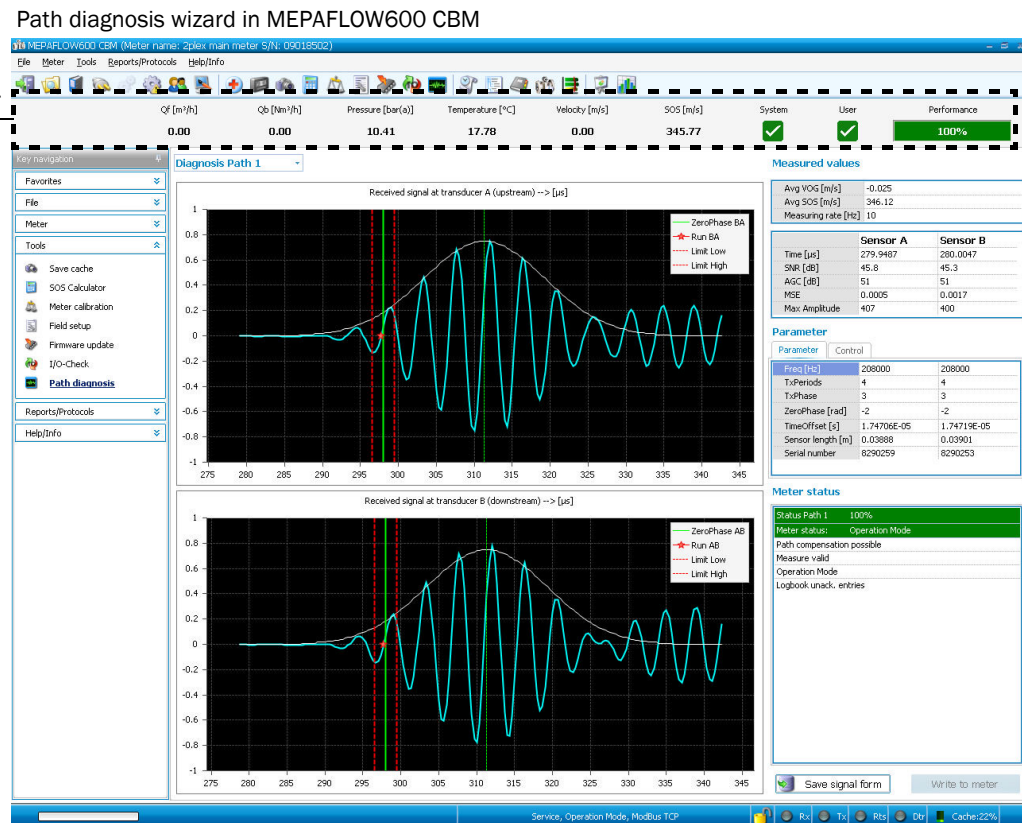

Checking the validity of the zero phases

- 1 Call up the "Meter Status" window (→ p. 167, Fig. 72). Open the register "Advanced or Path Status".
- 2 Check display "Adapt":
 - If the LED icon for "Adapt" is on: The zero phase setting is incorrect.

Checking the sound velocity (only for 2-path configuration)

- 1 Call up the "Meter values" page.
- 2 Call up the context menu of the sound velocity diagram (click in the diagram with the right mouse button).
- 3 Call up the display of the absolute sound velocities and deviation from mean value (→ p. 150, Fig. 65), and check the sound velocities displayed.

Criteria for correct sound velocities:

- The absolute sound velocity is more or less equal for all measuring paths.
- The deviation from the mean value is less than 0.1 % for all measuring paths.
- The absolute sound velocities deviate maximum 0.3% from the calculated theoretical sound velocity (→ p. 154, 9.5.1).

+i Sound velocity differences can be very high when the gas velocity in the pipeline is very low (< 1 m/s) (effect of thermal stratification). In this case, sound velocities in the top measuring path are higher than those in the bottom measuring path.

Fig. 64 Signal window displaying the ultrasonic signal on page "Path diagnosis"

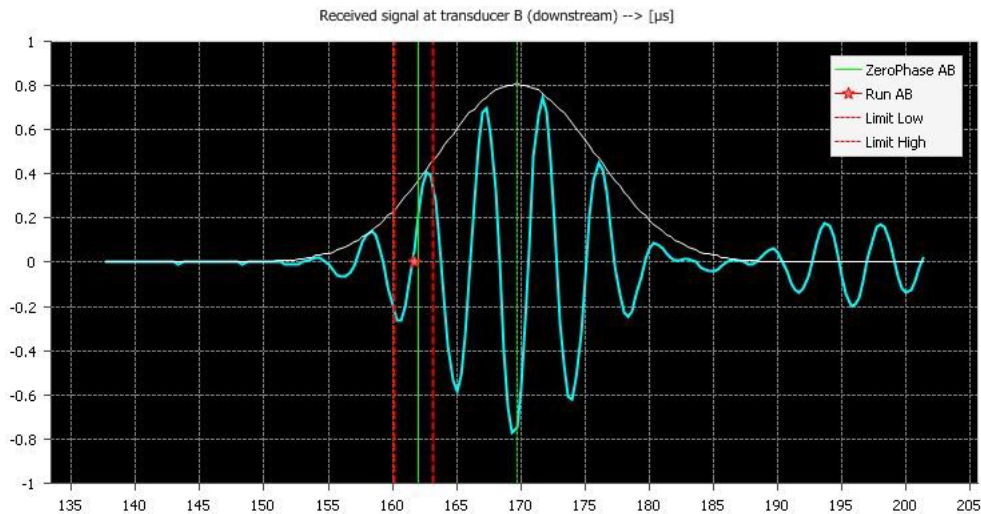
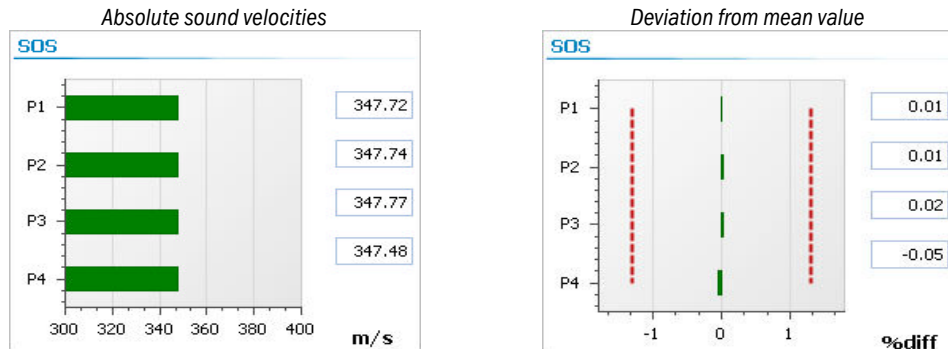

Fig. 65 Sound velocity per measuring path on page "Meter values"



FLOWSIC300

9 Maintenance

Protective measures when working on the pipeline

Maintenance work overview

Checking gas tightness

Functional check

Documentation/data backup

9.1 **Protective measures when working on the pipeline**

	<p>NOTICE: Risk of damage in pipeline</p> <ul style="list-style-type: none"> ▶ Protect the ultrasonic sensors against liquids and mechanical effects. Otherwise the ultrasonic sensors can be damaged or made unusable.
---	---

Before carrying out repair or cleaning work in the pipeline:

- ▶ Remove the ultrasonic sensors and replace them by the optional dummy plugs.

If the pipeline is to be purged with liquid:

- ▶ Obtain safety information from the FLOWSIC300 manufacturer. Observe this safety information.

9.2 **Components with gas contact in the pipeline**

During operation:	<ul style="list-style-type: none"> - Nozzle - Ultrasonic sensors - Sender/receiver units
During installation/maintenance work on sender/receiver units:	<ul style="list-style-type: none"> - Ball valve - Hydraulic cylinder of the fitting tool

9.3 **Maintenance work overview**

Checks during operation

- Check gas tightness (→ p. 153)
- Functional check
 - Comparing theoretical and measured sound velocity (SOS) (→ p. 154)
 - Checking the device state (→ p. 155)
 - Time synchronization (→ p. 156)
 - Maintenance reports (→ p. 157)

Operation documentation

- Maintenance reports (→ p. 157)
- Checking the logbook (→ p. 158)

	<ul style="list-style-type: none"> ● The FLOWSIC300 has no mechanical moving parts. ● Internal threshold values can be configured to trigger a warning when contamination starts.
---	---

	<ul style="list-style-type: none"> ▶ <i>Recommendation:</i> Create and file regular Maintenance reports (→ p. 157, §9.6). To do this, document current operating conditions (gas composition, pressure, temperature, flow velocity). – Maintenance reports can be useful during troubleshooting. ▶ Observe the documented operating conditions when comparing Maintenance reports.
---	--

9.4

Checking gas tightness

- ▶ Regularly check installations on the pipeline are gas-tight.
Should a leak occur:
 - Check the installation
 - Remove and check seals concerned
 - Replace seals concerned when damaged
- ▶ *Additionally in potentially explosive atmospheres:* Check the housing of the electronics unit corresponds to the degree of protection (condition of door and cover seals, cable inlets)

	<p>WARNING: Hazards through leaks</p> <p>Operation in leaky condition is not allowed and possibly dangerous. <i>If the installation is not gas-tight:</i></p> <ol style="list-style-type: none"> 1 If necessary, take protective measures against the escaping gas (e.g. alarm, breathing protection, shutdown). 2 Establish leak tightness again (replace seals)
---	---

	<p>WARNING: Hazard through wrong spare parts</p> <p>Seals must be made of materials suitable for the individual operating conditions (pressure, temperature, chemical influences).</p> <ul style="list-style-type: none"> ▶ Observe information provided on delivery on individual device versions (compare → p. 14, § 1.4.1). ▶ Only use specified seal versions. -<i>Recommendation:</i> Only use original spare parts from the manufacturer. ▶ Observe the installation information in these Operating Instructions.
---	---

9.5 **Functional check**

Proper device function can be determined directly on the LC display of the FLOWSIC300. The MEPAFLOW600 CBM program provides a user-friendly option for carrying out routine checks.

9.5.1 **Comparing theoretical and measured sound velocity (SOS)**

One of the main criteria for correct operation of an ultrasonic gas flow meter is conformity between the theoretical sound velocity calculated for the actual gas composition, temperature and pressure, and the sound velocity measured by the ultrasonic gas flow meter.

The SOS Calculator provided by the MEPAFLOW600 CBM program calculates a theoretical sound velocity for a specific gas composition at specified temperature and pressure values (→ Fig. 66). Calculating thermodynamic characteristics is based on the “GERG-2004 Wide-Range method for natural gas and other mixtures”. The algorithms implemented in the SOS Calculator were developed by the Ruhr-University Bochum (Germany).

Fig. 66 SOS Calculator with loaded gas composition file

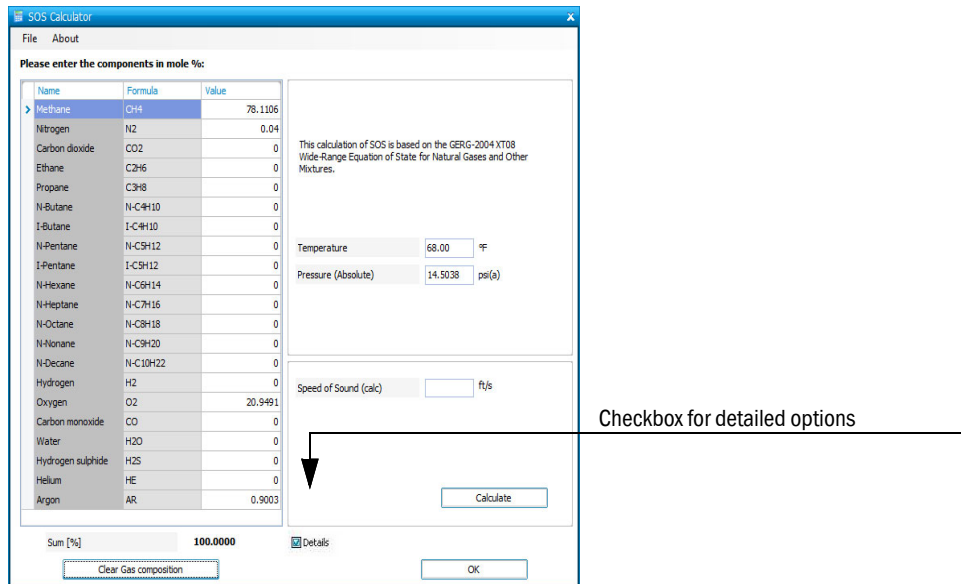

- ▶ Use the MEPAFLOW600 CBM program to connect to a device (→ p. 128, 8.3).
- ▶ Start the SOS Calculator in the Maintenance report or select “Tools / SOS Calculator” in the menu.
- ▶ Enter the gas composition and temperature and pressure for your application.
- ▶ Activate “Details” for additional settings.
- ▶ Click the “Calculate” button.
- If you have started the SOS Calculator in the Maintenance report, the calculated value is copied automatically to the corresponding field in the wizard and in the report.
- Compare the theoretical sound velocity with the sound velocity measured with the FLOWSIC300 (see Fig. 67, main system bar).
- If the deviation exceeds 0.3%, check the plausibility of temperature, pressure and gas composition.

9.5.2 Checking the device state

The FLOWSIC300 checks its own state with a system of user warnings and alarms. The device state need not be checked manually when the outputs are configured so that they display alarms and / or user warnings.

The “Main system bar” in MEPAFLOW600 CBM provides a compact overview when visual feedback on the state of your FLOWSIC300 is desired:

- ▶ Use the MEPAFLOW600 CBM program to connect to your FLOWSIC300 (→ p. 128, 8.3).
- ▶ Check the main system bar for any yellow or red icons (→ Fig. 67). A red or yellow icon signals a potential problem with the FLOWSIC300.

Continue checking the “Meter state” (→ p. 165, 10.2.1) and “User warnings” (→ p. 168, 10.2.2) should icons in the main status bar be yellow or red.

Fig. 67 Main system bar

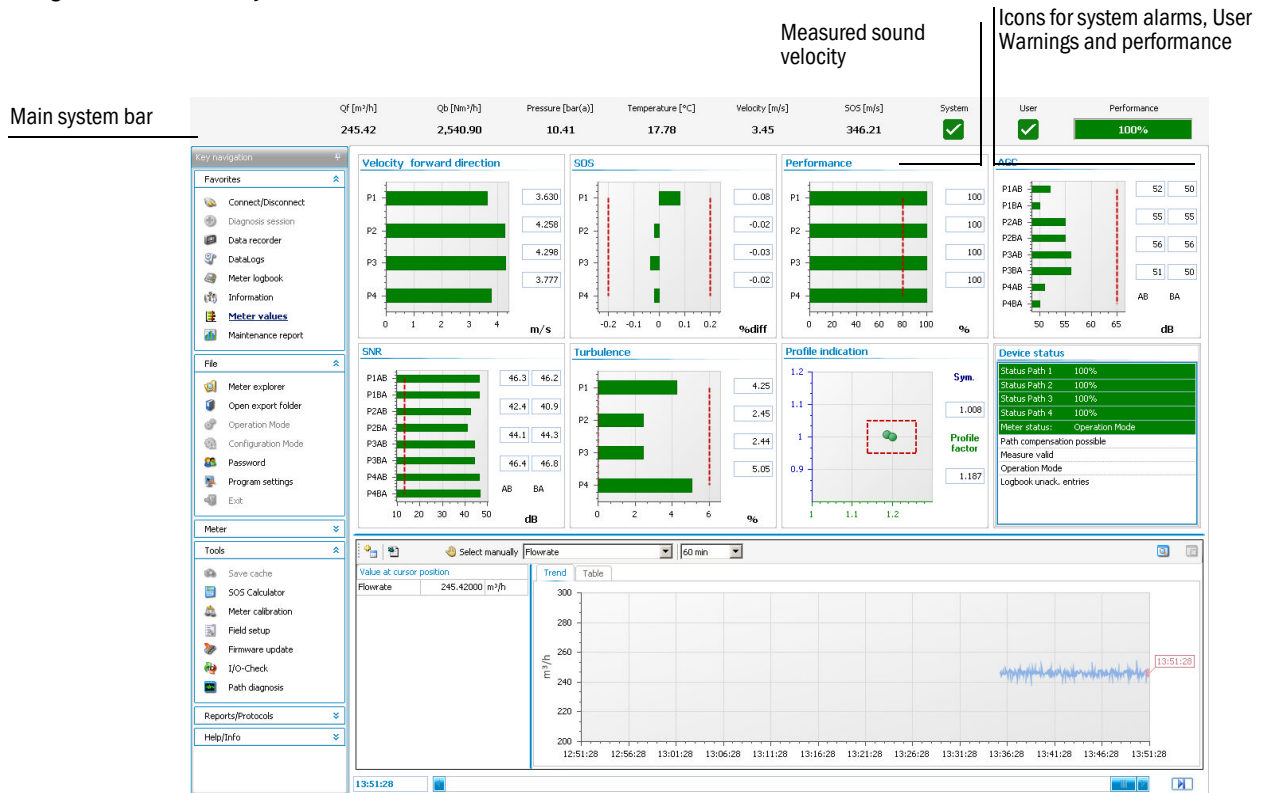

9.5.3 Time synchronization

Internal clock

- Entries in logbooks and DataLogs are stored with the date and time of the internal clock (“timestamp”).
- The internal clock can be read out with a main clock (e.g. PC clock) via MODBUS or with MEPAFLOW600 CBM.

Synchronizing via MODBUS

The date and time of the FLOWSIC300 can be set separately with an external write operation. Each operation for date and time triggers a separate entry in the Custody logbook [1].

Alternatively the synchronization function can be used. To use this method, the date register (#5007) and the time register (#5008) must be written within two seconds of each other. The date register (#5007) must be written first. The write operation can be done via MODBUS without setting the FLOWSIC300 to Configuration mode.

Synchronizing via MEPAFLOW600 CBM

MEPAFLOW600 CBM offers a synchronization function via a button in the “Meter Information” screen (→ Fig. 68). The icon is marked with a yellow character to indicate synchronization when the time difference between internal and PC clock is more than 30 seconds.

Fig. 68 Synchronization button and clock synchronization window

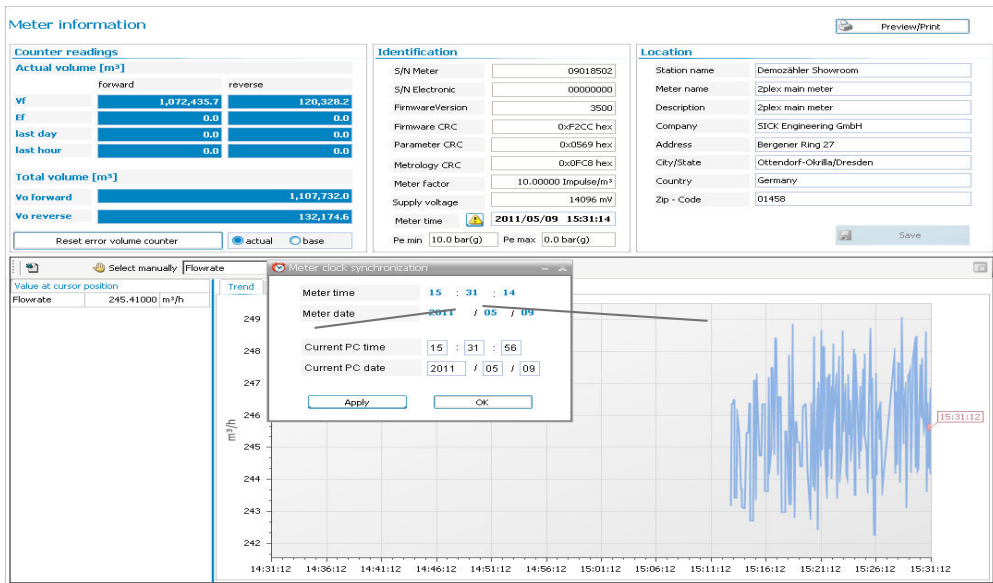

i Synchronization only triggers an entry in the calibration regulation logbook [1] when the time change is more than 3% of the time since the last synchronization.

9.6 **Maintenance reports**

We recommend creating and filing Maintenance reports on a regular basis. Over a period of time, this provides a comparison data base useful when diagnosing problems.

 Operating conditions (gas composition, pressure, temperature, flow velocity) in the Maintenance reports should be similar or documented each time and then considered when evaluating the comparison.

Fig. 69 Maintenance report wizard



- To create a Maintenance report, follow the described procedure:
- ▶ Select “Tools / Maintenance report” to open the wizard (→ Fig. 69).
 - ▶ Enter the information (Description, Technician) in the fields provided.
 - ▶ Enter the collection duration. This is the time in which the current device data are to be recorded to document the device status (default: 1 minute).
 - ▶ Enter the current pressure, temperature and sound velocity (SOS). Use the SOS Calculator to calculate the sound velocity for the gas composition (→ p. 154, 9.5.1). The gas composition must be current and representative.
 - ▶ Click “Start” to start recording current data. Diagnosis data, measured values and status information will be collected over the specified time span and will be saved in the meter database.
 - ▶ Click “Create report”. This creates and displays the Maintenance report.
 - ▶ Print the Maintenance report and file it together with the Manufacturer Data Report (MDR, in scope of delivery). Apart from that, the data are stored in the MEPAFLOW600 CBM Device database and can be retrieved using “Meter explorer” and “Report manager”. The Maintenance report can also be exported to Excel using the direct link provided when the Maintenance report is displayed.

9.7 **Logbook backup**

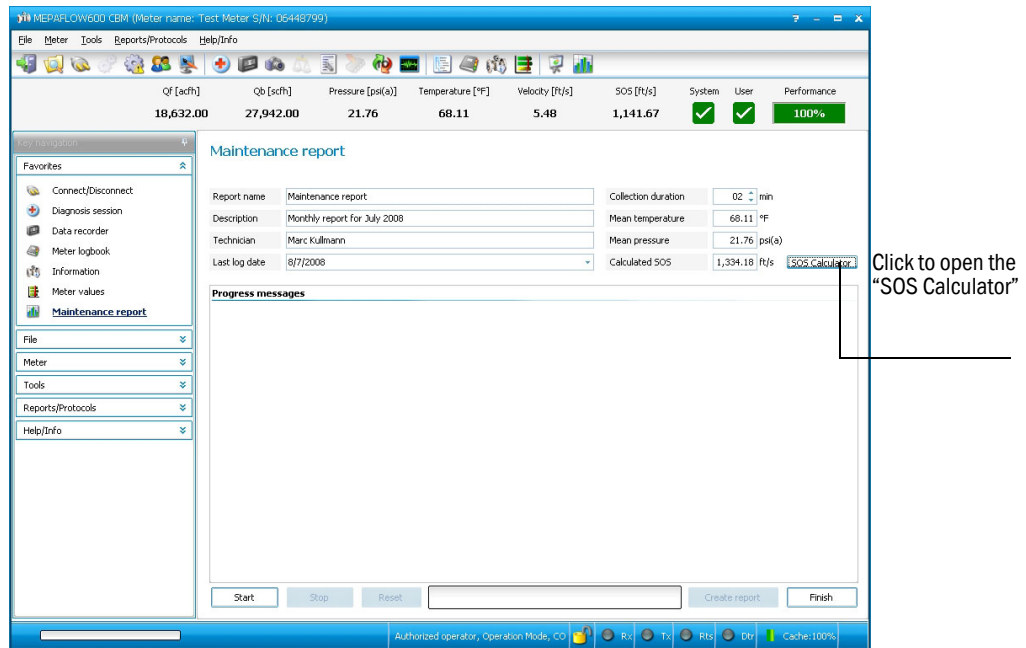
9.7.1 **Checking the logbook**

i To prevent a data overflow in the logbook and possible data losses, logbook entries (events) can be stored in a Device database using the MEPAFLOW600 CBM program. The entries can then be deleted in the device.

The “Meter logbook” page displays all logbook entries on the device and in the MEPAFLOW600 CBM database. It provides details on each entry and information on the number of registered events and the remaining memory space.

Fig. 70 “Meter logbook” page in MEPAFLOW600 CBM

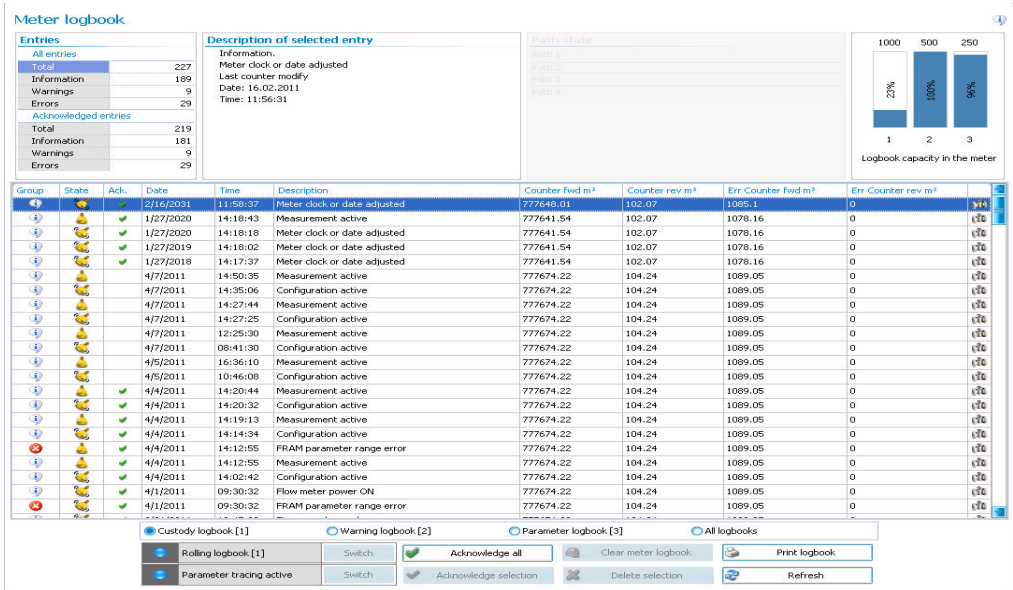

9.7.1.1 **Downloading and storing the logbook entries in the MEPAFLOW database**

Proceed as follows to download and save the logbook entries in the MEPAFLOW600 CBM database:

- ▶ Use the MEPAFLOW600 CBM program to connect to a device (→ p. 128, 8.3).
- ▶ Select “Meter / Logbook” in the menu to open the Logbook page.
- ▶ Select the logbooks to be downloaded in the “Logbook selection” dialog box and click “OK”.

The logbook entries are now loaded to your MEPAFLOW600 CBM database. The entries can then be viewed offline without connecting to the device or can be used with other users (export device or session).

9.7.1.2 **Confirming logbook entries on the device**

Proceed as follows to confirm logbook entries:

- ▶ Download and store the logbook entries as described in → 9.7.1.1.
- ▶ Select the logbook in which entries are to be acknowledged or select “All logbooks” to acknowledge entries in all logbooks at once.
- ▶ Mark the entries to be acknowledged.
- ▶ Click “Acknowledge selection” when only selected entries are to be confirmed or “Acknowledge all” to confirm all entries in the selected logbook or selected logbooks.

9.7.1.3 **Deleting logbooks on the device**

Logbooks need not be deleted on the device when the logbooks are configured as “rolling”. When the logbook is full, new entries will overwrite the oldest entries.

If a logbook is configured as “blocking” (e.g. with calibration regulation configuration), a full Custody logbook [1] activates device status “Data invalid”. In this case, it is recommended to clear the logbooks.



NOTICE:

The following conditions must be fulfilled to clear logbooks on the device:

- The Parameter write lock must be in the “UNLOCKED” position.
- The user must be in the “Service” user level (see Service manual for password).
- The device must be in Configuration mode.

Proceed as follows to clear logbooks on the device:

- 1 Select user access level “Service” (→ p. 129, 8.3.2)
- 2 Download and store the logbook entries → 9.7.1.1.
- 3 Select the logbook to be deleted on the device. Or select “All Logbooks” to empty all logbooks at the same time.
- 4 Set the device to Configuration mode.
- 5 Click “Clear meter logbook” and confirm the warning with “OK”.
- 6 Set the device to measuring operation.
- 7 *If the parameter write lock was released to clear the logbooks:* Reset to the original state.

9.7.2 DataLogs check

FLAWSIC300 has two DataLogs (Hourly Log and Daily Log). They save averaged measured values and are stored in the SPU's non-volatile memory (FRAM). All data can be downloaded and exported to Excel files with MEPAFLOW600 CBM.

+ Full support for the DataLogs is provided by MEPAFLOW600 CBM V1.1.00 or higher.

Fig. 71 DataLogs page with opened tab for Hourly Logs

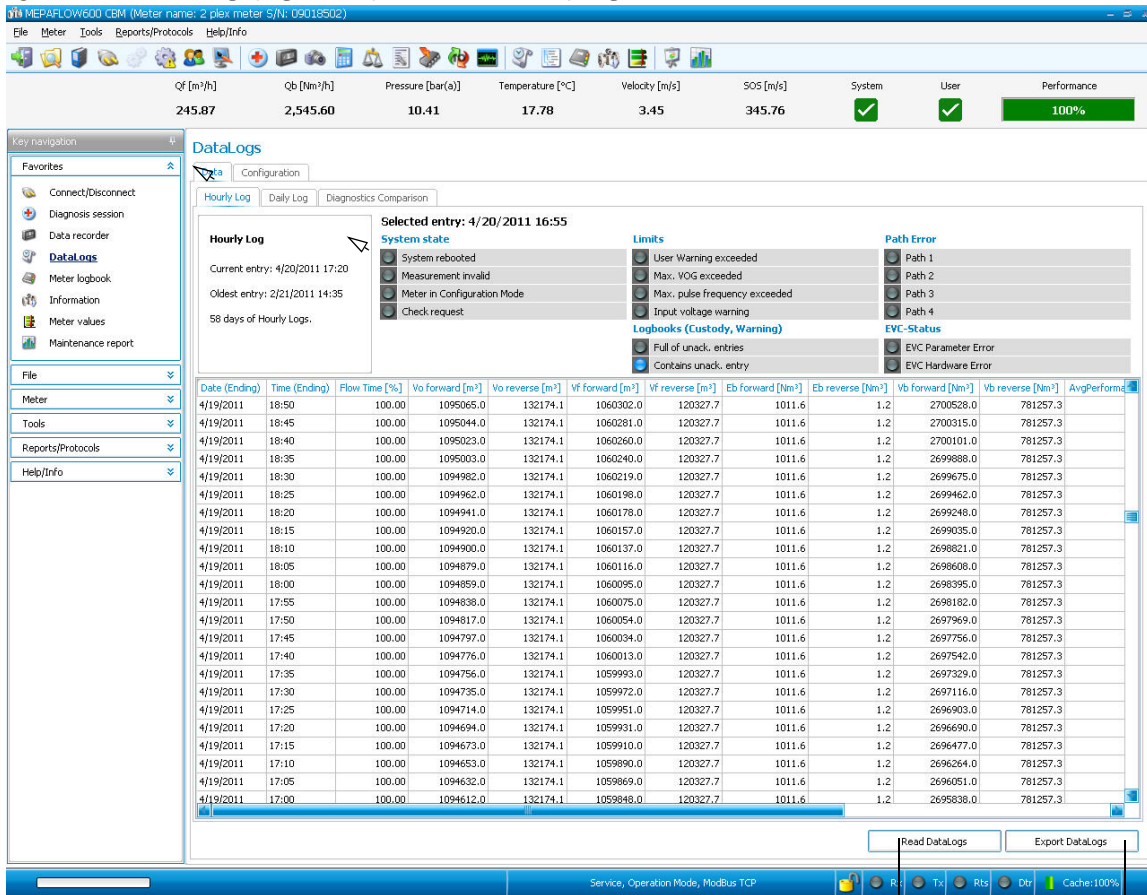

for update

for export

9.7.2.1 **Downloading and exporting of DataLog data**

To download and export the data from your FLOWSIC300, complete the following steps:

- ▶ Use MEPAFLOW600 CBM to connect to the meter.
- ▶ Go to the DataLogs page (choose “Meter / DataLogs” from the menu).
- ▶ In the dialog “DataLog selection”, select those DataLogs that you want to view and/or export and click “OK”.
- ▶ Now the DataLogs page is displayed with the data from the meter.
- ▶ If you select a DataLog entry, its time stamp and the meter status (see below) is shown in the middle section.
- ▶ To update the data from the meter, use the button “Read DataLogs”.
- ▶ To export DataLog data to an Excel file (.xls), use the button “Export DataLogs”.



Meter status

In every DataLog entry, a condensed meter status information is saved. It shows all meter status information that became active during the storage cycle - even if it was for the shortest period of time.

If a meter status information bit is shown active in a DataLog entry, the logbooks will contain a corresponding entry with more information.

- ▶ Always check the logbooks, if you require more information about the meter status information in the DataLogs.

Flow weighted diagnostic information in DataLog data

The datasets do not contain any diagnostic information for gas velocities below the value for the parameter V_{min} (Reg. #7036 “LowFlow-CutOff”). The “Flow time” value shows, for what percentage of the duration of the storage cycle the flow was above V_{min} and in the flow direction specified for the DataLog.

All diagnostic information is flow-weighted.

9.7.2.2 **Clearing entries from DataLogs**

If the DataLogs are configured with the storage behavior “rolling”, it is not necessary to clear the entries from the DataLogs on the meter. When the DataLog is full, new entries will overwrite the oldest entries.

If a DataLog is configured with the storage behavior “blocking”, the DataLog will stop saving new entries when it is full and a yellow light will indicate the full DataLog on the meter status table. In this case it is recommended to clear the entries from the DataLogs.

To clear all entries from a DataLog, complete the following steps:

- ▶ Go to the DataLogs page (choose “Meter / DataLogs” from the menu).
- ▶ Choose the “Configuration” tab.
- ▶ Switch the meter into Configuration Mode (choose “File / Configuration Mode” from the menu).
- ▶ Click the “Clear” button for the DataLogs from which you want to clear entries.
- ▶ Switch the meter into Operation Mode.

FLOWSIC300

10 Troubleshooting

- General troubleshooting
- Displaying status alarms and warnings
- Starting a diagnosis session
- Troubleshooting when connecting devices



This Section helps locating the cause of a problem when routine tests during maintenance (→ p. 154, 9.5) or function checks after start-up (→ p. 148, 8.6) show that a measuring problem could possibly exist.

If the cause of the problem cannot be localized, it is recommended to use the MEPAFLOW600 CBM software to record the current parameter set and diagnosis values in a diagnosis session file (→ p. 170, § 10.3) and send this to a local Endress+Hauser representative.

10.1 **General troubleshooting**

Problem	Possible causes	Actions
<ul style="list-style-type: none"> ● No display ● No pulse frequency ● No active status signal 	Faulty power supply	<ul style="list-style-type: none"> ▶ Check input voltage on terminals 1 and 2. ▶ Check cables and terminal connections. <p>Caution Take the relevant safety precautions!</p>
	Device defective	<ul style="list-style-type: none"> ▶ If possible, start a diagnosis session (→ p. 170, § 10.3) and contact your local Endress+Hauser representative.

10.2 **Displaying status alarms and warnings**

The FLOW300 signals alarms and warnings as follows:

- The LCD display shows active device status alarms or warnings. If a current error or warning is active, the display will flash and a message will be displayed with a message number in the upper right corner (→ p. 181, 12.5.1 for more details on LCD error messages).
 - A status output can be configured to signal whether device status “Data invalid”, “Check request” or “Warning” will be active.
 - Device status registers can be read out via MODBUS (see document “FLOW300 Modbus Specification”)
 - The MEPAFLOW600 CBM program can be used to test the device state. Device status alarms and warnings are displayed in the main system bar.
- ▶ *Recommendation:* Use MEPAFLOW600 CBM to receive further information on the device state.
 - ▶ *If “Data invalid” or “Check request” is displayed on the device:* Proceed as shown in → p. 165, 10.2.1.
 - ▶ *If “Warning” is displayed on the device:* Proceed as shown in → p. 168, 10.2.2.

10.2.1 **Checking the device status**

The “Meter Status” window in MEPAFLOW600 CBM shows an overview on the status and operation of the device.

- ▶ Use the MEPAFLOW600 CBM program to connect to a device (→ p. 128, 8.3).
- ▶ Click “System” in the main system bar to open the “Meter Status” window (→ p. 167, Fig. 72).
- ▶ Check the “Meter Status” section (→ p. 167, Fig. 72) for yellow or red lamps.

Device status lamp	Possible causes	Actions
Green lamp for “Measurement valid”	Correct operating state. The measured values are valid.	-
Red lamp for “Data invalid”	Device does not output valid measurements. Measuring volumes are counted in the error volume counter [1].	Measurement is invalid and/or the device is in Configuration mode. ▶ <i>If the device is in Configuration mode:</i> Select “File / Operation mode” in the menu to switch the device to measuring operation. ▶ <i>Otherwise:</i> Process as shown in §10.3 (→ p. 170).
Yellow lamp for “Check request”	- <i>For 1-path measurement:</i> A malfunction is affecting measuring precision.[1] - <i>For 2-path measurement (option):</i> A measuring path has failed or another malfunction is affecting measuring precision.[1]	▶ Proceed according to §10.3 (→ p. 170).
Yellow lamp for “User Warning Limit exceeded”.	A user warning limit has been exceeded.	▶ Check the user warning as shown in §10.2.2 (→ p. 168).
Red lamp for “Path failure”	- <i>For 1-path measurement:</i> The measuring path has failed. - <i>For 2-path measurement (option):</i> Both measuring paths have failed.	▶ Proceed according to §10.3 (→ p. 170).

[1] See p. 39, §2.8.2 for further details on device status.

- ▶ If none of the lamps are yellow or red in the general section “Meter Status”, the other sections can be checked for yellow or red lamps.

Device status lamp	Possible causes	Actions
Yellow lamp “Logbook(s) contain unack. entries”	Logbook contains unconfirmed entries.	▶ Download, check and confirm all logbook entries (→ p. 158, 9.7.1.1.).
Red lamp when a logbook has status “full”	<ul style="list-style-type: none"> ● The corresponding logbook is configured as “blocking”. ● This logbook is full. 	<ul style="list-style-type: none"> ▶ Download, check and confirm all logbook entries (→ p. 158, 9.7.1.1.). ▶ Clear the device logbook (→ p. 159, 9.7.1.3). ▶ Check whether the logbook should be configured as “rolling” (see Parameters).
		<ul style="list-style-type: none"> ▶ Download, check and confirm all logbook entries (→ p. 158, 9.7.1.1.). ▶ Clear the device logbook (→ p. 159, 9.7.1.3).
Red lamp when a DataLog has status “full”	<ul style="list-style-type: none"> ● The corresponding DataLog is configured as “blocking”. ● This DataLog is full. 	<ul style="list-style-type: none"> ▶ Download and check the DataLog. ▶ Clear the DataLog. ▶ Consider reconfiguring the DataLog to “rolling”.
Yellow light “Battery Lifespan (change battery)”	Automatically activated after 8.5 years to prompt replacing the battery.	<ul style="list-style-type: none"> ▶ Inform Endress+Hauser Service technicians to have the internal battery replaced. ● Information on battery → p. 169, 10.2.3. ● See the Service Manual for instructions on replacing the battery.

Fig. 72 Main system bar with “System” button and open window “Meter Status”

Opens the “Meter Status” window

Main system bar

Qf [m³/h]	Qb [Nm³/h]	Pressure [bar(a)]	Temperature [°C]	Velocity [m/s]	SOS [m/s]	System	User	Performance
20.20	301.68	14.48	19.44	1.30	346.93	✓	✓	100%

General section “Meter Status”

Displays whether logbook(s) contains unacknowledged entries

Battery change

“Logbooks” section

“DataLogs” section

Meter Status

Meter 5/N: 09018502 Meter date/time: 5/5/2011 16:04:36

Operating Mode

Operation Mode	●
Configuration Mode	●
Air test active	●

Meter Status

Measurement valid	●
Check request	●
User Warning Limit exceeded	●
Path failure (see advanced)	●

System

Volume counter CRC error (a.c.)	●
Volume counter CRC error (s.c.)	●
I/O Impulse out of range	●
System time invalid (RTC error)	●
Firmware CRC error	●
Logbook(s) contains unack. entries	●
Battery LifeSpan (change battery)	●
Signature error	●

Electronic Volume Corrector (EVC)

EVC hardware error	●
EVC parameter invalid	●
HART com. p error	●
HART com. T error	●

Measurement

DSP error	●
DSP boot error	●
DSP measure invalid	●
Adjust range error	●
Path compensation valid	●
Continuous measure mode	✓
Filter Mode active	✓

Logbooks

	CRC Error	Full
Custody Logbook [1]	●	●
Warning Logbook [2]	●	●
Parameter Logbook [3]	●	●

DataLogs

	CRC Error	Full
Diagnostic Comparison (DataLog 1)	●	●
Hourly Log (DataLog 2)	●	●
Daily Log (DataLog 3)	●	●

Parameter write lock: UNLOCKED
Unit system in meter: METRIC

Legend

- OK, no alarm or warning active
- Warning active
- Alarm active
- Disabled
- ✓ On (enabled/active)
- Off (disabled/inactive)

Window always on top

10.2.2 **Checking user warnings**

The “User Warnings” window displays an overview of the user warning status.

- ▶ Use the MEPAFLOW600 CBM program to connect to a device (→ p. 128, 8.3).
- ▶ Click “User” in the main system bar in the MEPAFLOW600 CBM screen to open the “User Warnings” window (→ Fig. 73).
- ▶ Check the window for yellow lights and proceed according to → p. 170, § 10.3.

Fig. 73 Main system bar with “User” button and open window “User Warnings”

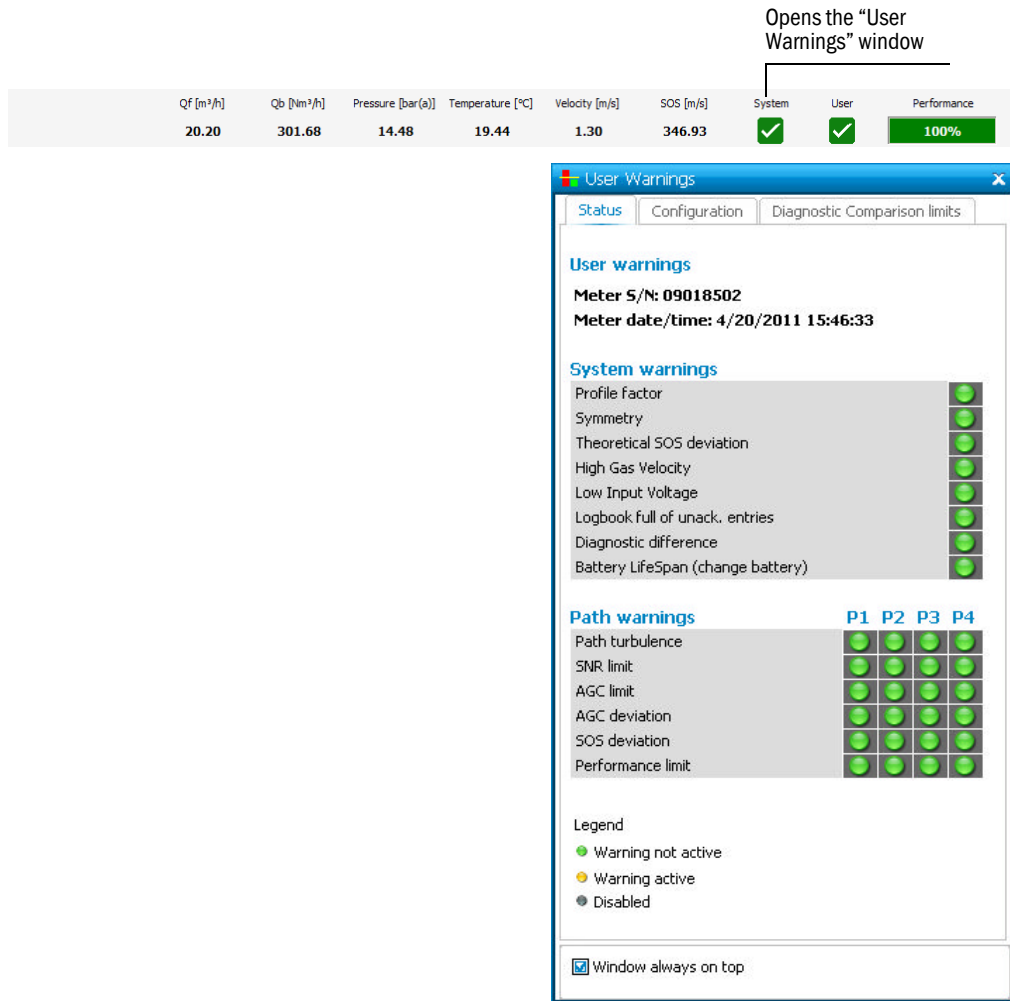

10.2.3 **Battery service life/capacity**

The real-time clock (RTC) in the FLOWSIC300 is buffered by a battery. The battery service life specified by the manufacturer is at least 10 years. The remaining battery capacity can be inquired on the display in the first menu level (see “Technical Information”).

Fig. 74 Display of remaining battery capacity on the LCD display

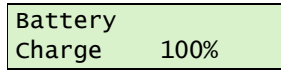

Because the FLOWSIC300 has no regular maintenance cycle, a user warning will be automatically generated if the remaining battery life is less than 15%. After 8.5 years, a warning is generated which forces the operator to change the battery. The battery may only be changed by trained staff.

The procedure for changing the battery is described in the Service Manual.

10.3 Starting a diagnosis session

If it becomes necessary to generate a diagnosis session for remote support, follow the procedure described below:

- ▶ Start the MEPAFLOW600 CBM program and establish an online connection to the device (see → p. 128, 8.3 for all preparations required).
- ▶ Select “Tools / Diagnosis session” in the menu or click menu item “Diagnosis session” in the button navigation (see → Fig. 75)

Fig. 75 Starting a “Diagnosis session”

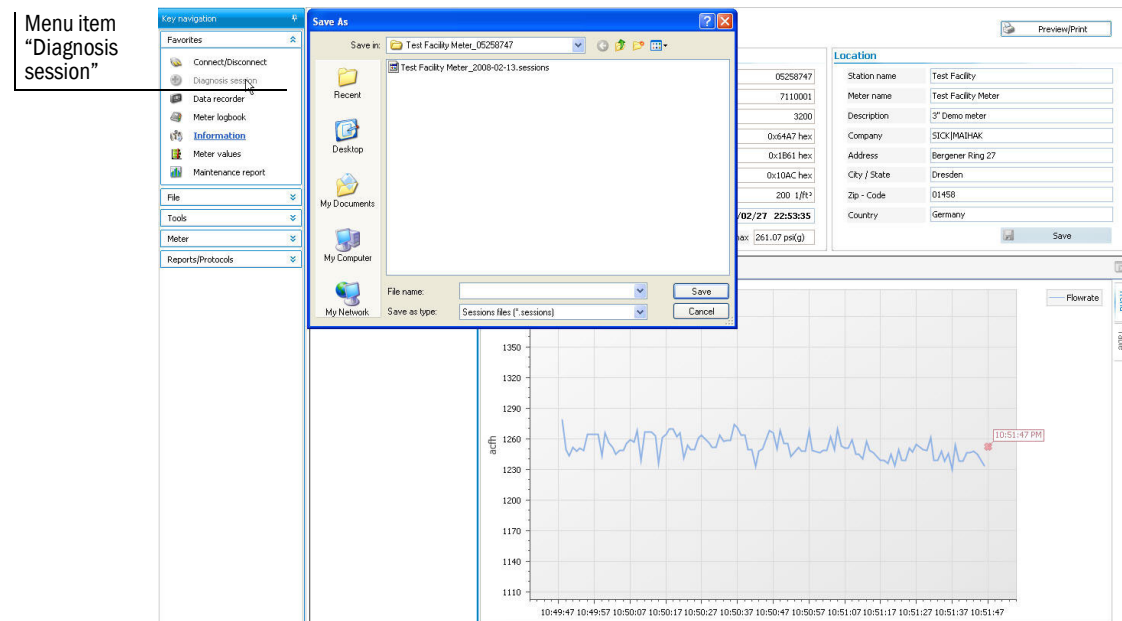

- ▶ Specify a file name. (The file path is set according to the program settings. If desired, specify a different path.)
- ▶ Click “Save”.
- ▶ MEPAFLOW600 CBM now loads the logbooks from the device and starts a diagnosis session with all the relevant data. The entire process usually takes about three minutes. If the logbooks contain a lot of entries, the process may take longer.
- ▶ E-mail the Diagnosis session file to your Endress+Hauser representative for support.

10.4 **Troubleshooting when connecting devices**

Device not found during first connection

- ▶ Check all cables and the hardware. Also check that the adapters have been installed correctly (see → §8.2.1 and → §8.2.2).
- ▶ Use the options in the windows displayed to allow MEPAFLOW600 CBM to search with advanced options (see → Fig. 76).

Fig. 76 Dialog window "Meter not found" to specify advanced search options

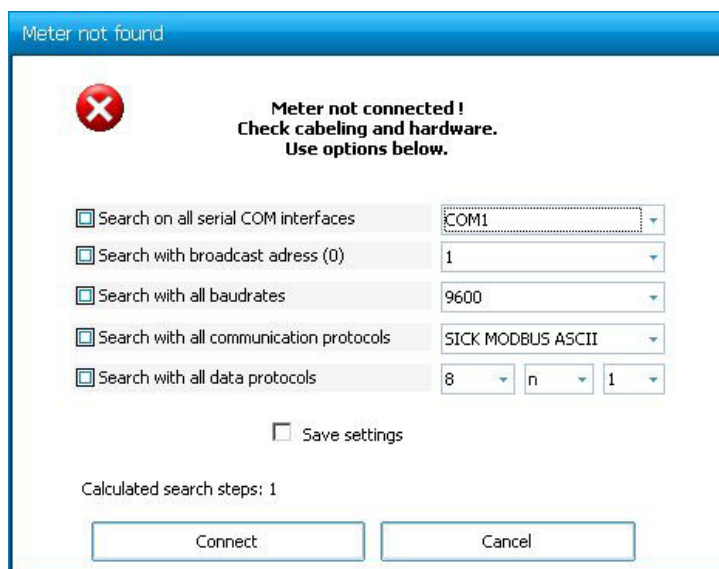

Connection lost during session

- ▶ Check all cables and the hardware.
- ▶ Use the options in the windows displayed to allow MEPAFLOW600 CBM to search with advanced options (see → Fig. 76), especially when parameters have possibly been changed (e.g baudrate).

FLOWSIC300

11 Spare parts

Electronics subassembly
Sender/receiver units
Cables
Fitting tool

11.1

Electronics subassembly**Junction box**

Description	Part No.
Junction box 1-path, with connection for cable conduit	2 066 967
Junction box 1-path, without connection for cable conduit	2 066 964
Junction box 2-path, with connection for cable conduit	2 066 965
Junction box 2-path, without connection for cable conduit	2 066 968

Electronics subassemblies

Description	Part No.
LC-Display	2 066 184
Fuse board with assembly parts	2 041 502
Buffer battery	7 048 533

Connection block

Description	Part No.
Connection block for hardware variants 1, 2, 4, 5, 7, 8, 9, A Rev2 (EMC circuit board, master board)	2 062 870
Connection block for hardware variants 6 and B Rev2 (EMC circuit board, master board)	2 056 878

Electronics block I/O config. 3, cable length 5 m

Description	Part No.
Electronics block IIC/BCD 200 kHz (power,SPU,I/O,analog) (for I/O config. 1/1, 1/2, 1/3, 7/1, 7/2, 7/3)	2 040 387

Electronics block I/O config. 3, cable length 15 m

Description	Part No.
Electronics block IIC/BCD 300 kHz (power,SPU,I/O,analog)	2 046 540

Electronics block I/O config. 5, cable length 5 m

Description	Part No.
Electronics block IIC/BCD H 200 kHz (power,SPU,I/O,analog) (for I/O config.2/4, 2/5, 3/6, 8/4, 8/5)	2 040 389

Electronics block I/O config. 5, cable length 15 m

Description	Part No.
Electronics block IIC/BCD 300kHz (power,SPU,I/O,analog) with analog output / HART	2 046 542

Electronics block I/O config. C, cable length 5 m

Description	Part No.
Electronics block IIC/BCD for I/O variant C, cable length 5m, FL300-NNCNNNSN	2 067 051

Electronics block I/O config. C, cable length 15 m

Description	Part No.
Electronics block IIC/BCD for I/O variant C, cable length 15 m, FL300-NNCNNNLN	2 067 053

11.2 **Sender/receiver units**

Description	Part No.
Sender/receiver unit assembly set	2 066 974
O-ring 36.0 * 2.5, VITON LT170-TT for probe holder	2 067 525
Sealing cover for S/R unit FLSE300 with seal, without connection for cable conduit	2 067 031
Sealing cover for S/R unit FLSE300 with seal, with connection for cable conduit	2 067 032
Extraction tool for probe holder, T-handle	2 066 972
1 pair of spare probes X8 including probe holder and O-ring	2 067 809
1 pair of handles for adjusting ring S/R unit FLSE300	2 067 515

11.3 **Cables**

Description	Part No.
Sensor cable 5m, without cable conduit	2 066 955
Sensor cable 5m, with cable conduit	2 066 956
Sensor cable 15 m, with cable conduit	2 066 954

11.4 **Fitting tool**

Description	Part No.
Hydraulic hose for hand pump for FLOWSIC300 fitting tool with hydraulic coupling	2 067 522
Compact ball valve 2" for FL300 fitting tool	2 066 951
Hydraulic cylinder 2" for FLOWSIC300 fitting tool	2 066 952
Hand pump for FLOWSIC300 fitting tool	2 066 953
Sealing set for probe change, including 1x flat seal, 1x fitting tool O-ring, 1x probe holder O-ring	2 066 174

FLOWSIC300

12 Appendix

Conformities
Technical data
Logbooks

12.1 **Conformities**

12.1.1 **CE certificate**

The FLOWSIC300 has been developed, manufactured and tested in accordance with the following EU Directives:

- ATEX Directive 2014/34/EU
- EMC Directive 2014/30/EU

Conformity with the above Directives and current EU Standards has been determined and the CE label attached to the device.

12.1.2 **IECEX**

Conformity with the IEC standards used, see IECEX Certificate.

12.2 **Technical data**

Table 4 Technical data measuring system FLOWSIC300

Meter characteristics and measuring parameters		
Measured variables	Actual flow rate, actual volume, gas velocity, speed of sound	
Number of measuring paths	1, 2	
Measuring principle	Ultrasonic transit time difference measurement	
Measured medium	Natural gas, process gases, high-pressure flare gases, air	
Measuring ranges	Gas velocity: 0.3 ... 60 m/s, depending on the nominal pipe width	
Measurement span	Max. 1:130	
Repeatability	< 0.5% of measured value	
Measurement uncertainty	1% ... 5% of measured value (depending on device configuration)	
Gas temperature	-40 °C ... +180 °C	
Operating pressure	10 bar (g) ... 100 bar (g)	
Nominal pipe size	4" ... 56"	
Ambient conditions		
Ambient temperature	-40 °C ... +60 °C	
Storage temperature	-40 °C ... +70 °C	
Ambient humidity	≤ 95% relative humidity; non-condensing	
Approvals		
Ex certification	ATEX: Ex II 1/2 G Ex db eb ib [ia Ga] IIC T4 Ga/Gb IECEx: Ex d e ib [ia Ga] IIC T4 Ga/Gb Ultrasonic sensors are intrinsically safe "ia".	
Electrical safety	CE	
IP classification	Sender/receiver units	IP68
	Control unit SPU	IP65/IP67
Outputs and interfaces		
Analog output	1 output: 4 ... 20 mA; 200 Ω Active/passive, electrically isolated	
Digital outputs	3 outputs: Passive, electrically isolated, open collector or acc. to NAMUR (EN 50227), f _{max} = 6 kHz (scalable)	
Interfaces	1 RS-485 (for configuration, measured value output and diagnosis)	
Bus protocol	MODBUS ASCII/RTU HART	
Installation		
Dimensions (W x H x D)	See dimension drawings	
Weight	Sender/receiver unit: ± 15 kg Control unit SPU: ± 6 kg Nozzle 1.5" Cl.600: ± 5 kg	
Assembly	Connection 1.5" Cl.600 according to ANSI B16.5 for welding to pipeline Sensor cable length: 5 m or 15 m Installation of control unit SPU to 2" tube or wall fitting	
Electrical connection		
Voltage	12 V ... 24 V DC, +20% (with active analog output: 15 ... 28.8 V)	
Power input	< 1 W	

Table 5 Technical data fitting tool FLOWSIC300

Operating parameters	
Gas temperature	-30 °C ... +100 °C
Operating pressure	0 ... 100 bar(g) for fitting the sensor 10 ... 100 bar(g) for removing the sensor
Medium	Natural gas and gas mixtures similar to natural gas; Use for other gases only on request.
Ambient conditions	
Ambient temperature	-10 °C ... +45 °C
Storage temperature	-20 °C ... +60 °C
Installation	
Dimensions (W x H x D)	See dimension drawings
Weight	Fitting tool in case: ± 45 kg

12.3 Dimensions

Clearance required next to the pipeline	→ p. 54, Fig. 16
Electronics unit dimensions	→ p. 107, Fig. 36

12.4 Measuring ranges

Nominal size		Typical inner diameter	Maximum actual flow rate		Maximum speed
			[m ³ /h]	[ft ³ /h]	
DN 100	4"	102.3	1,700	59,500	60
DN 150	6"	154.1	3,300	115,500	50
DN 200	8"	202.7	5,200	182,000	45
DN 250	10"	254.4	7,300	255,500	40
DN 300	12"	304.8	8,600	301,000	33
DN 350	14"	336.6	10,500	367,500	33
DN 400	16"	387.4	14,000	490,000	33
DN 450	18"	438.2	17,900	626,500	33
DN 500	20"	489	22,300	780,500	33
DN 600	24"	590.6	32,500	1,137,500	33
DN 700	28"	692.2	40,600	1,421,000	30
DN 750	30"	743	46,800	1,638,000	30
DN 800	32"	793.8	53,400	1,869,000	30
DN 900	36"	895.4	68,000	2,380,000	30
DN 1000	40"	992.2	83,500	2,922,500	30
DN 1050	42"	1,043	92,200	3,227,000	30
DN 1100	44"	1,093.8	94,700	3,314,500	28
DN 1200	48"	1,195.4	109,000	3,815,000	27
DN1300	52" *	1,290	122,300	4,280,500	26
DN1400	56" *	1,390	136,500	4,777,500	25

The maximum flow rate can be limited further by the operating pressure and damping effects
* Not standardized according to ANSI B36.10.

12.5

Logbooks

Classification of logbook entries

Entries are split into three classes and identified by the initial character in the first line.

Identification	Significance
I	Information
W	Warning
E	Error / malfunction

Type of occurrence

Identification	Significance
+	Event timepoint marking the start of a state
-	Event timepoint marking the end of a state

12.5.1

Overview of entries in logbooks and MEPAFLOW600 CBM

Message No. on LCD	Logbook message in MEPAFLOW600 CBM	Logbook	LCD text
Custody logbook [1]			
3002	No DSP communication	1	E+System 0001 NO DSP-Communic. E-System 0001 NO DSP-Communic.
3003	Data invalid	1	E+DSP 0001 Reading invalid E-DSP 0001 Reading invalid
3004	Firmware CRC invalid	1	E+Firmware 0001 CRC invalid E-Firmware 0001 CRC invalid
3005	Parameter CRC invalid	1	E+Parameter 0001 CRC invalid E-Parameter 0001 CRC invalid
3006	Parameter out of range	1	E+Parameter 0001 #XXXX range error E-Parameter 0001 #XXXX range error
3007	Failure during storage of path compensation parameter	1	E+PathComp. 0001 Storage error E+PathComp. 0001 Storage error
3008	Meter clock time invalid	1	E+System 0001 ClockTime inval. E-System 0001 ClockTime inval.
3011	CRC volume counter (a.c) invalid	1	E+Count.ac 0001 CRC invalid E-Count.ac 0001 CRC invalid

Message No. on LCD	Logbook message in MEPAFLOW600 CBM	Logbook	LCD text
3012	CRC volume counter (n.c) invalid	1	E+Count.sc 0001 CRC invalid
			E-Count.sc 0001 CRC invalid
3013	Transit time mode activated	1	E+System 0001 TransitTimeMode
			E-System 0001 TransitTimeMode
3014	No signature key	1	E+System 0001 No signature key
			E-System 0001 No signature key
2001	Path failure	1	W+PathError 0001 Path 1 2
			W-PathError 0001 All paths OK
2002	No HART communication to temperature transmitter	1	W+HART T 0001 No communication
			W-HART T 0001 No communication
2003	No HART communication to pressure transmitter	1	W+HART P 0001 No communication
			W-HART P 0001 No communication
2004	Maximum pulse output frequency exceeded (6kHz)	1	W+PulseOut 0001 6000 Hz exceeded
			W-PulseOut 0001 6000 Hz exceeded
2005	EVC parameter invalid	1	W+EVC 0001 EVC para.invalid
			W+EVC 0001 EVC para.invalid
2006	EVC hardware error	1	W+EVC 0001 EVC module error
			W+EVC 0001 EVC module error
1001	Flow meter power ON	1	I Power ON 0001 dd/mm/yy mm:ss
1002	Meter clock adjusted	1	I Set Time 0001 dd/mm/yy mm:ss
1003	Configuration Mode active	1	I+Meas.Mode 0001 Maintenance ON 1
			I-Meas.Mode 0001 Measurement ON 1
1004	Firmware changed	1	I Update Fw 0001 3104 -> 3200
1014	Overflow volume counter (a.c.)	1	I Count.ac 0001 Overflow
1015	Overflow volume counter (s.c.)	1	I Count.sc 0001 Overflow

Message No. on LCD	Logbook message in MEPAFLOW600 CBM	Logbook	LCD text
1016	Error volume counter cleared	1	I Reset E 0001 01/01/07 10:47
1017	All volume counters cleared	1	I Reset V 0001 01/01/07 10:47
1027	Parameter error → factory parameters have been loaded	1	I+InitError 0001 DefaultParaLoad I-InitError 0001 DefaultParaLoad
1029	Air test mode activated	1	I+Airtest 0001 Active I-Airtest 0001 Not active
Warning logbook [2]			
1008	Warning logbook [2] erased and initialized	2	I Logbook 2 0001 Reset and Init
1010	Warning logbook [2] overflow	2	I+Logbook 2 0001 Overflow I-Logbook 2 0001 Overflow
1018	DataLog 1 cleared	2	I DataLog 1 0001 Reset
1019	DataLog 2 cleared	2	I DataLog 2 0001 Reset
1020	DataLog 3 cleared	2	I DataLog 3 0001 Reset
1021	DataLog 1 overflow	2	I+DataLog 1 0001 Overflow I-DataLog 1 0001 Overflow
1022	DataLog 2 overflow	2	I+DataLog 2 0001 Overflow I-DataLog 2 0001 Overflow
1023	DataLog 3 overflow	2	I+DataLog 3 0001 Overflow I-DataLog 3 0001 Overflow
1024	DatenLog 1 CRC error	2	I+DataLog 1 0001 CRC invalid I-DataLog 1 0001 CRC invalid
1025	DatenLog 2 CRC error	2	I+DataLog 2 0001 CRC invalid I-DataLog 2 0001 CRC invalid

Message No. on LCD	Logbook message in MEPAFLOW600 CBM	Logbook	LCD text
1026	DataLog 3 CRC error	2	I+DataLog 3 0001 CRC invalid
			I-DataLog 3 0001 CRC invalid
1028	Customer limit exceeded Limit value mask 0XXXXXXXXX (specifies limit value exceeded)	2	I+Userlimit 0001 Limit XXXXXXXXXXXX
			I-Userlimit 0001 Limits OK
Parameter logbook [3]			
1005	Parameter changed	3	I Parameter 0001 Parameter changed Reg3001
1006	All parameters to default (Reset)	3	I Parameter 0001 Reset all
1009	Parameter logbook [3] erased and initialized	3	I-Logbook 3 0001 Reset and Init
1011	Parameter logbook [3] overflow	3	I+Logbook 3 0001 Overflow
			I-Logbook 3 0001 Overflow

12.6

SPU terminal assignment

Connection in accordance with ATEX IIC

Fig. 77

Terminal assignment in accordance with ATEX IIC

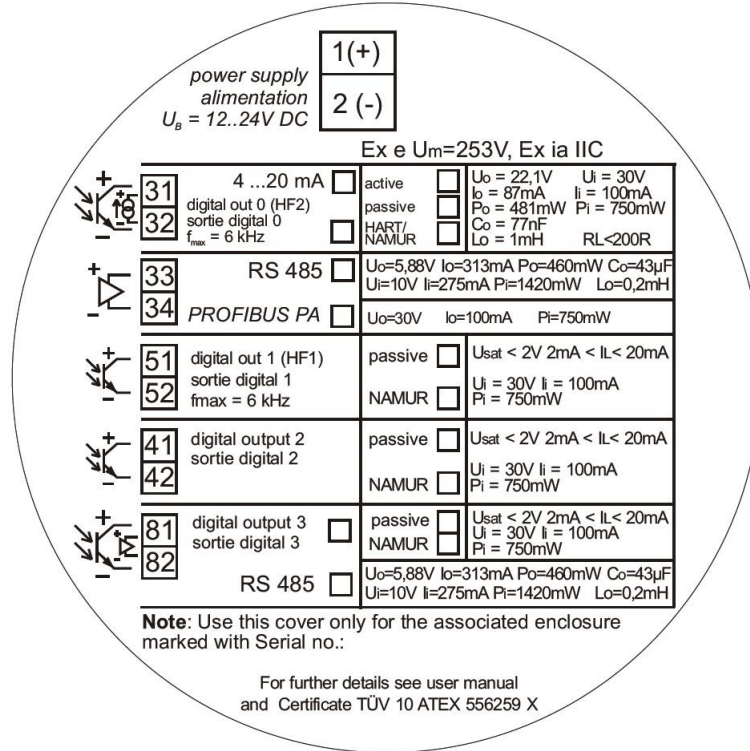

12.7.2

Non intrinsically safe installation

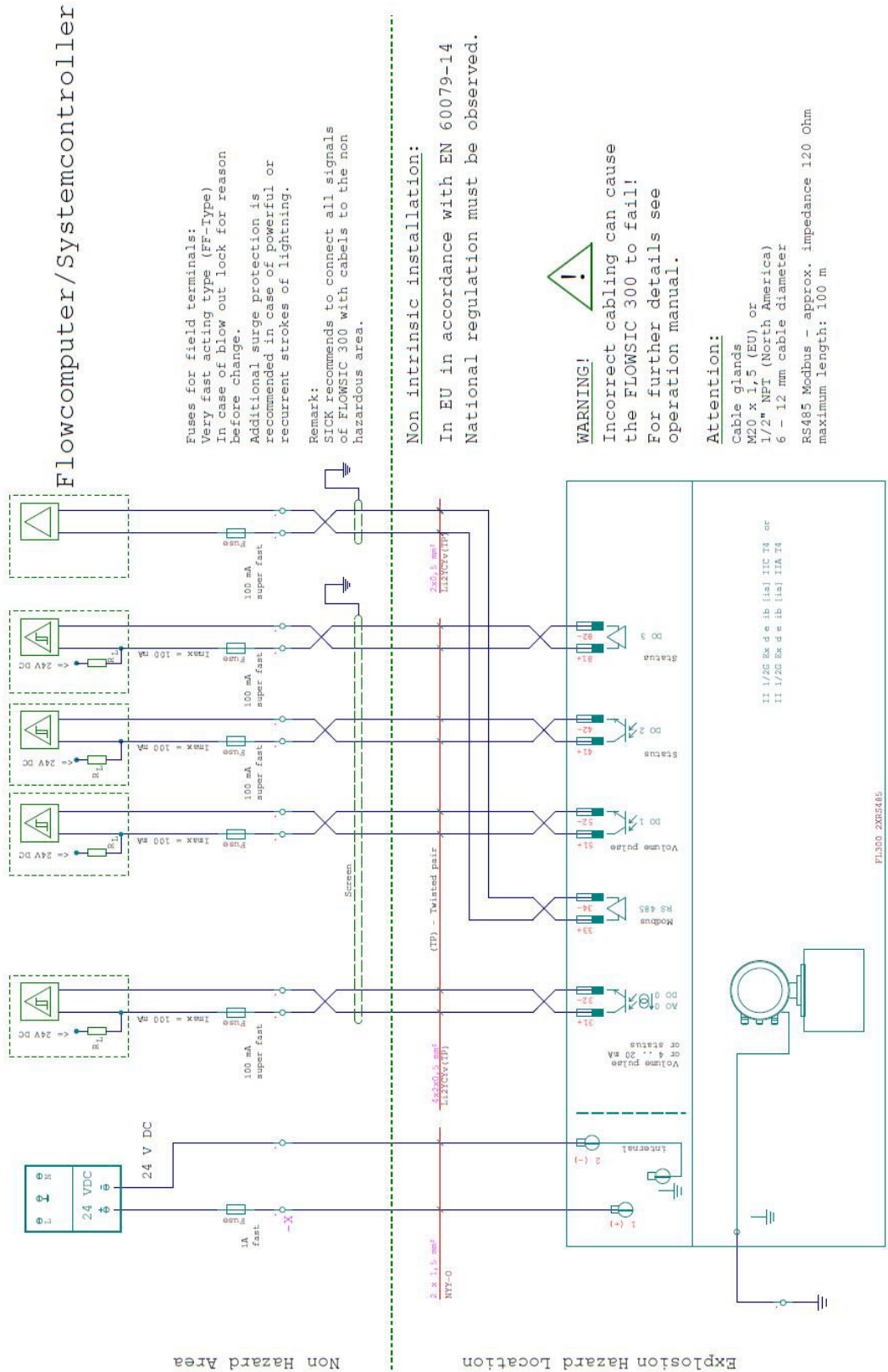

Flowcomputer/Systemcontroller

Fuses for field terminals:
Very fast acting type (FF-Type)
In case of blow out lock for reason before change.
Additional surge protection is recommended in case of powerful or recurrent strokes of lightning.

Remark:
SICK recommends to connect all signals of FLOW SIC 300 with cables to the non hazardous area.

Non intrinsic installation:

In EU in accordance with EN 60079-14
National regulation must be observed.



WARNING!
Incorrect cabling can cause the FLOW SIC 300 to fail!
For further details see operation manual.

Attention:

- Cable glands
M20 x 1,5 (EU) or
1/2" NPT (North America)
- 6 - 12 mm cable diameter
- RS485 Modbus - approx. impedance 120 Ohm
maximum length: 100 m









Non Hazard Area

Explosion Hazard Location

FL300 2X65485



12.8 **Type plates**

Fig. 78 FLOWSIC300 SPU type plate (example)

Made in Germany		Endress+Hauser 	
FLOWSIC300		Endress+Hauser SICK GmbH+Co. KG Bergener Ring 27, 01458 Ottendorf-Okrilla, Germany	
Type code	<input type="text" value="00"/>	<input type="text" value="12"/>	
Serial no.	<input type="text" value="02"/>		
Part no.	<input type="text" value="01"/>		
U _{nom}	12...24 V DC	  II 1/2 G IP65/IP67 Ex db eb ib [ia Ga] IIC T4 Ga/Gb TÜV 10 ATEX 556259 X Ex d e ib [ia IIC Ga] IIC T4 Ga/Gb IECEx TUN 11.0001X	
I _{max}	150 mA		
U _m	253 V		
T _a	-40...+60 °C	  	
 WARNING: Explosion hazard Read operation instructions before installation.			
		 Date <input type="text" value="03"/>	

Pos.	Significance
00	Device type
01	Part number (material number)
02	Serial number
03	Date (YYYY-MM)
12	Datamatrix-Code

Fig. 79 FLOWSIC300 type plate on the sender/receiver units (example)

Made in Germany		Endress+Hauser 	
FLOWSIC300		Endress+Hauser SICK GmbH+Co. KG Bergener Ring 27, 01458 Ottendorf-Okrilla, Germany	
Type code	<input type="text" value="00"/>	<input type="text" value="03"/>	
Serial no.	<input type="text" value="02"/>		
Part no.	<input type="text" value="01"/>		
p _{max}	100 bar @180 °C	Ex ia IIC T6 Ga	
T _p	-40...+180 °C		
Flange size 1.5" CL600 ASME B16.5		 	

Pos.	Significance
00	Type code
01	Part number
02	Serial number
03	2D-Code

Fig. 80 Type code FLOWsic300 SPU

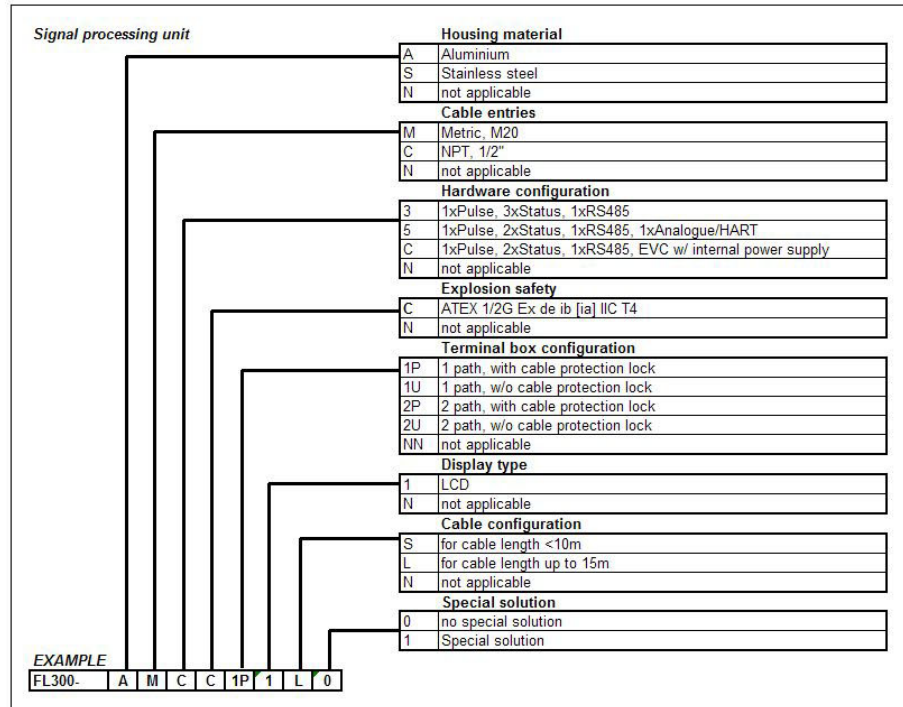
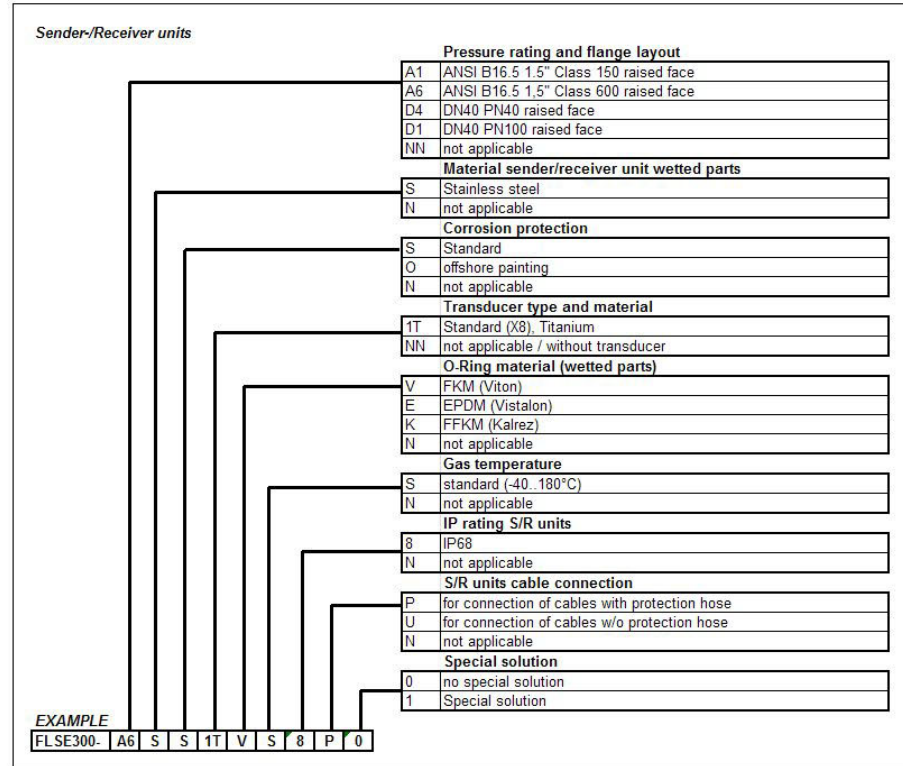

Fig. 81 Type code sender/receiver units FLSE300



8029798/AE00/V2-2/2025-12

www.addresses.endress.com
