

# Safety Instructions

## Display FHX50

NEPSI: Ex ia IIC T4/T6 Ga  
Ex iaD 21 T100/T105



Document: XA01076F-B  
Safety instructions for electrical apparatus for explosion-hazardous areas → 3



# Display FHX50

## Table of contents

|   |   |
|---|---|
| Associated documentation . . . . .                | 4 |
| Supplementary documentation . . . . .             | 4 |
| Manufacturer's certificates . . . . .             | 4 |
| Manufacturer address . . . . .                    | 4 |
| Extended order code . . . . .                     | 4 |
| Safety instructions: General . . . . .            | 6 |
| Safety instructions: Special conditions . . . . . | 6 |
| Safety instructions: Installation . . . . .       | 7 |
| Safety instructions: Zone 0 . . . . .             | 7 |
| Temperature tables . . . . .                      | 8 |
| Connection data . . . . .                         | 8 |

|                                    |   |                               |   |                                  |   |                  |                      |  |                               |  |                                  |
|------------------------------------|---|-------------------------------|---|----------------------------------|---|------------------|----------------------|--|-------------------------------|--|----------------------------------|
| <b>Associated documentation</b>    | This document is an integral part of the following Operating Instructions:<br>SD01007F/00   |                               |   |                                  |   |                  |                      |  |                               |  |                                  |
| <b>Supplementary documentation</b> | Explosion-protection brochure: CP00021Z/11<br>The Explosion-protection brochure is available: <ul style="list-style-type: none"> <li>■ In the download area of the Endress+Hauser website:<br/><a href="http://www.endress.com">www.endress.com</a> -&gt; Downloads -&gt; Media Type: Documentation -&gt; Documentation Type: Brochures and catalogs -&gt; Text Search: CP00021Z</li> <li>■ On the CD for devices with CD-based documentation</li> </ul>  |                               |   |                                  |   |                  |                      |  |                               |  |                                  |
| <b>Manufacturer's certificates</b> | <b>NEPSI Declaration of Conformity</b><br><br>Certificate number:<br>GYJ18.1032X<br><br>Affixing the certificate number certifies conformity with the following standards (depending on the device version): <ul style="list-style-type: none"> <li>■ GB3836.1-2010</li> <li>■ GB3836.4-2010</li> <li>■ GB3836.20-2010</li> <li>■ GB12476.1-2013</li> <li>■ GB12476.4-2010</li> </ul>   |                               |   |                                  |   |                  |                      |  |                               |  |                                  |
| <b>Manufacturer address</b>        | Endress+Hauser SE+Co. KG<br>Hauptstraße 1<br>79689 Maulburg, Germany<br>Address of the manufacturing plant: See nameplate.  |                               |   |                                  |   |                  |                      |  |                               |  |                                  |
| <b>Extended order code</b>         | The extended order code is indicated on the nameplate, which is affixed to the device in such a way that it is clearly visible. Additional information about the nameplate is provided in the associated Operating Instructions.<br><br><b>Structure of the extended order code</b><br><br><table border="0" style="margin-left: 40px;"> <tr> <td style="text-align: center;">FHX50</td> <td style="text-align: center;">-</td> <td style="text-align: center;">*****</td> <td style="text-align: center;">+</td> <td style="text-align: center;">A*B*C*D*E*F*G*..</td> </tr> <tr> <td style="text-align: center;"><i>(Device type)</i></td> <td></td> <td style="text-align: center;"><i>(Basic specifications)</i></td> <td></td> <td style="text-align: center;"><i>(Optional specifications)</i></td> </tr> </table> <p>* = Placeholder<br/>At this position, an option (number or letter) selected from the specification is displayed instead of the placeholders.</p> <p><i>Basic specifications</i></p> <p>The features that are absolutely essential for the device (mandatory features) are specified in the basic specifications. The number of positions depends on the number of features available. The selected option of a feature can consist of several positions.</p> <p><i>Optional specifications</i></p> <p>The optional specifications describe additional features for the device (optional features). The number of positions depends on the number of features available. The features have a 2-digit structure to aid identification (e.g. JA). The first digit (ID) stands for the feature group and consists of a number or a letter (e.g. J = Test, Certificate). The second digit constitutes the value that stands for the feature within the group (e.g. A = 3.1 material (wetted parts), inspection certificate).</p> | FHX50                         | - | *****                            | + | A*B*C*D*E*F*G*.. | <i>(Device type)</i> |  | <i>(Basic specifications)</i> |  | <i>(Optional specifications)</i> |
| FHX50                              | -   | *****                         | + | A*B*C*D*E*F*G*..                 |   |                  |                      |  |                               |  |                                  |
| <i>(Device type)</i>               |   | <i>(Basic specifications)</i> |   | <i>(Optional specifications)</i> |   |                  |                      |  |                               |  |                                  |

More detailed information about the device is provided in the following tables. These tables describe the individual positions and IDs in the extended order code which are relevant to hazardous locations.

#### Extended order code: Display FHX50



The following specifications reproduce an extract from the product structure and are used to assign:

- This documentation to the device (using the extended order code on the nameplate).
- The device options cited in the document.

#### Device type

FHX50

#### Basic specifications

| Position 1, 2 (Approval) |    |                           |
|--------------------------|----|---------------------------|
| Selected option          |    | Description               |
| FHX50                    | NA | NEPSI Ex ia IIC T4/T6 Ga  |
|                          | NM | NEPSI Ex iaD 21 T100/T105 |

| Position 3 (Display; Operation) |   |   |
|---------------------------------|---|---|
| Selected option                 |   | Description   |
| FHX50                           | A | None, use existing device display                         |
|                                 | C | SD02 4-line, push buttons + data backup function          |
|                                 | E | SD03 4-line, illum., touch control + data backup function |

| Position 4 (Housing) |   |                                  |
|----------------------|---|----------------------------------|
| Selected option      |   | Description                      |
| FHX50                | B | Single compartment, 316L         |
|                      | C | Single compartment, alu, coated  |
|                      | D | Single compartment, plastics PBT |

| Position 5 (Cable)  |   |   |
|---------------------|---|---|
| Option sélectionnée |   | Description   |
| FHX50               | A | 5m + M12 plug                                       |
|                     | B | 10m + M12 plug                                      |
|                     | D | 20m + M12 plug                                      |
|                     | E | 30m + M12 plug                                      |
|                     | 1 | Provided by customer, M16, max 60m                  |
|                     | 2 | Provided by customer, NPT1/2, max 60m <sup>1)</sup> |

1) Only in connection with Position 4 (Housing) = B or C

| Position 6 (Option Measurement Device) |   |   |
|--|---|---|
| Selected option                        |   | Description                                   |
| FHX50                                  | A | Prepared for remote display FHX50             |
|  | B | Not prepared for display FHX50 + retrofit kit |

*Optional specifications*

| ID Jx (Test, Certificate) |    |  |
|---------------------------|----|--|
| Selected option           |    | Description                            |
| FHX50                     | JN | Ambient temperature transmitter -50 °C |

**Safety instructions: General**

- Staff must meet the following conditions for mounting, electrical installation, commissioning and maintenance of the device:
  - Be suitably qualified for their role and the tasks they perform
  - Be trained in explosion protection
  - Be familiar with national regulations
- For installation, use and maintenance of the device, users must also observe the requirements stated in the Operating Instructions and the standards:
  - GB50257-2014: "Code for construction and acceptance of electric device for explosion atmospheres and fire hazard electrical equipment installation engineering".
  - GB3836.13-2013: "Explosive atmospheres, Part 13: Equipment repair, overhaul and reclamation".
  - GB3836.15-2000: "Electrical apparatus for explosive gas atmospheres, Part 15: Electrical installations in hazardous area (other than mines)".
  - GB3836.16-2006: "Electrical apparatus for explosive gas atmospheres, Part 16: Inspection and maintenance of electrical installation (other than mines)".
  - GB3836.18-2010: "Explosive atmospheres, Part 18: Intrinsically safe system".
  - GB15577-2007: "Safety regulations for dust explosive prevention and protection". (Only if installed in dust hazardous area.)
  - GB12476.2-2010: "Electrical apparatus for use in the presence of combustible dust, Part 2: Selection and installation". (Only if installed in dust hazardous area.)
- Install the device according to the manufacturer's instructions and national regulations.
- Do not operate the device outside the specified electrical, thermal and mechanical parameters.
- Avoid electrostatic charging:
  - Of plastic surfaces (e.g. housing, sensor element, special varnishing, attached additional plates, ..)
  - Of isolated capacities (e.g. isolated metallic plates)
- Modifications to the device can affect the explosion protection and must be carried out by staff authorized to perform such work by Endress+Hauser.

**Safety instructions:  
Special conditions**

Permitted ambient temperature range at the electronics housing:  
 $-40\text{ °C} \leq T_a \leq +80\text{ °C}$

*Optional specification, ID Jx (Test, Certificate) = JN*

Permitted ambient temperature range at the electronics housing:  
 $-50\text{ °C} \leq T_a \leq +80\text{ °C}$

- Observe the information in the temperature tables.
- In the event of additional or alternative special varnishing on the housing or other metal parts:
  - Observe the danger of electrostatic charging and discharge.
  - Do not rub surfaces with a dry cloth.

*Basic specification, Position 4 (Housing) = C*

In Zone 0, avoid sparks caused by impact and friction.

*Basic specification, Position 4 (Housing) = D*

Avoid electrostatic charging of the housing (e.g. friction, cleaning, maintenance, strong medium flow).

### Safety instructions: Installation

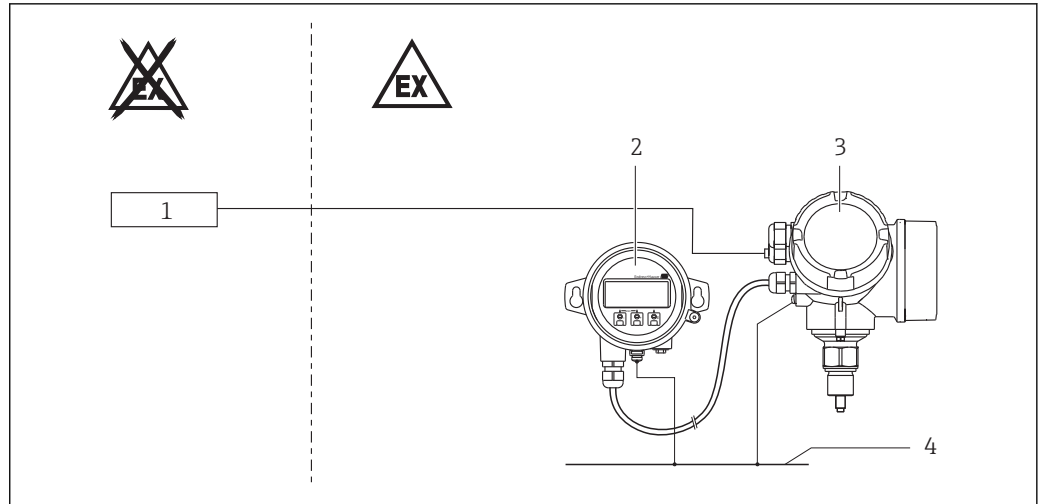

#### 1

- 1 Power supply or certified associated apparatus (dependent on Endress+Hauser measuring device)
- 2 Display FHX50 in Zone 0/1/2, Zone 21 or 22
- 3 Endress+Hauser measuring device
- 4 Local potential equalization

Continuous service temperature of the connecting cable:  $-40\text{ °C}$  to  $\geq +85\text{ °C}$ ; in accordance with the range of service temperature taking into account additional influences of the process conditions ( $T_{a,\min}$ ), ( $T_{a,\max} + 20\text{ K}$ ).

Optional specification, ID Jx (Test, Certificate) = JN

Continuous service temperature of the connecting cable:  $-50\text{ °C}$  to  $\geq +85\text{ °C}$ ; in accordance with the range of service temperature taking into account additional influences of the process conditions ( $T_{a,\min}$ ), ( $T_{a,\max} + 20\text{ K}$ ).

#### Intrinsic safety

- When the device is connected to an intrinsically safe circuit Ex ib, the type of protection changes to Ex ib. Do not operate intrinsically safe circuits Ex ib in Zone 0 or Zone 20.
- When the device is connected to an intrinsically safe circuit Ex ic, the type of protection changes to Ex ic. Do not operate intrinsically safe circuits Ex ic in Zone 0, Zone 1 or Zone 20, Zone 21.

#### Potential equalization

Integrate the device into the local potential equalization.

### Safety instructions: Zone 0

- In the event of potentially explosive vapor/air mixtures, only operate the device under atmospheric conditions.
  - Temperature:  $-20$  to  $+60\text{ °C}$
  - Pressure: 80 to 110 kPa (0.8 to 1.1 bar)
  - Air with normal oxygen content, usually 21 % (V/V)
- If no potentially explosive mixtures are present, or if additional protective measures have been taken, the device may also be operated under non-atmospheric conditions in accordance with the manufacturer's specifications.

**Temperature tables***Basic specification, Position 4 (Housing) = B, C*

| Zone 0, Zone 1, Zone 2 |                          |
|------------------------|--------------------------|
| Temperature class T6   | $T_a \leq +60\text{ °C}$ |

| Zone 21, Zone 22                                |         |
|---|---------|
| Max. surface temperature at $T_a +80\text{ °C}$ | +100 °C |

*Basic specification, Position 4 (Housing) = D*

| Zone 0, Zone 1, Zone 2 |                          |
|------------------------|--------------------------|
| Temperature class T6   | $T_a \leq +55\text{ °C}$ |

| Zone 21, Zone 22                                |         |
|---|---------|
| Max. surface temperature at $T_a +80\text{ °C}$ | +105 °C |

**Connection data****FHX50**

| Power supply and signal circuit   |
|---|
| $U_i = 7.3\text{ V}$<br>$I_i = 157\text{ mA}$<br>$P_i = 362\text{ mW}$<br>effective inner inductance $L_i = 0$<br>effective inner capacitance $C_i = 263\text{ nF}$ |

The device can be connected to a measuring device which has an intrinsically safe display circuit. For more information see "Connectable transmitters" section.

**Connectable transmitters**

- To connect the device to a measuring device, such as a measuring device from Endress+Hauser, it must meet the following conditions:
  - The device has an intrinsically safe display circuit
  - The device specifically bears the information "Prepared for display FHX50"
  - The device is prepared for display FHX50 using the retrofit kit
- Please note the "Connectable transmitters" section in the Special Documentation SD01007F provided!

*Basic specification, Position 6 (Option Measurement Device) = A, B*

All transmitters for which the device structure provides the "Prepared for display FHX50" (A) option can be converted using the retrofit kit (B).

Please note the "Extended order code" section in the Safety Instructions (XA) included with the transmitter.

The measuring device which has already been prepared for the FHX50 or converted using the retrofit kit has an intrinsically safe display circuit with the following characteristic values:

| Power supply and signal circuit  |
|--|
| $U_o = 7.3\text{ V}$<br>$I_o = 157\text{ mA}$<br>$P_o = 362\text{ mW}$<br>effective outer inductance $L_o = 149\text{ }\mu\text{H}$<br>effective outer capacitance $C_o = 388\text{ nF}$ |

**Connectable cables**

- Cables which are optionally available from Endress+Hauser: can be ordered up to a total length of 30 m.
- Maximum cable length: 60 m.
- The customer's own cable can be used if the total effective inductance and capacitance of the cable do not exceed the following values respectively:
  - Total inductance of cable  $L_c = 149 \mu\text{H}$
  - Total capacitance of cable  $C_c = 125 \text{nF}$

**Display module**

- Display module present in the measuring device: The display module removed during conversion using the retrofit kit can be installed in the FHX50.
- Display module present in the FHX50: No action necessary.
- Display module not present: Display module must be ordered.

*Basic specification, Position 6 (Option Measurement Device) = B*

- For information on the suitability of the display module for conversion, see the "Connectable transmitters" section.
- Identification marking to identify the suitability of the display module: [AA], [AB] or [AC].



---



[www.addresses.endress.com](http://www.addresses.endress.com)

---