

Installation Instructions

Flexdip CYA112 immersion assembly

Seals





Table of contents

1	Overview	3
2	Intended use	3
3	Authorized installation personnel	3
4	Safety instructions	3
5	Scope of delivery	4
6	Replacing the O-rings	6
7	Additional documentation	6
8	Disposal	6

1 Overview

1.1 Spare parts kits

Order code	Designation	Page
71094034	CYA112 O-rings for immersion tube	→  4
71094033	CYA112 O-rings for quick fastener	→  5

2 Intended use

- The parts in the kits are designed exclusively as maintenance parts for CYA112 submersible assemblies. Any other use is not permitted!
- Only use original parts from Endress+Hauser.
- In the Device Viewer, check if the spare part is suitable for the device in question.

3 Authorized installation personnel

- Installation, commissioning, operation and maintenance of the measuring system may be carried out only by specially trained technical personnel.
- The technical personnel must be authorized by the plant operator to perform the stated tasks.
- The electrical connection may only be established by an electrical technician.
- The technical personnel must have read and understood these Installation Instructions and must follow the instructions they contain.
- Measuring point faults may be repaired only by authorized and specially trained personnel.
- In the case of Ex-certified devices, the technical staff must also be trained in explosion protection.

 Repairs not described in the Operating Instructions provided must only be carried out directly at the manufacturer's site or by the service organization.

4 Safety instructions

WARNING

Risk of injury from high pressure, high temperatures, chemical hazards, or escaping medium!

- ▶ Before any maintenance task, depressurize and drain the system.
- ▶ Flush the assembly thoroughly before starting work, as it may contain medium residues.

⚠ CAUTION**Risk to health due to contact with the process medium!**

- ▶ Pay attention to the warnings in the safety data sheets.
- ▶ Wear protective gloves, protective goggles and protective clothing, particularly when working with reagents, chemicals or process solutions.
- ▶ In case of contact with eyes or skin, rinse the affected area with plenty of water and then seek medical advice. Show the relevant safety data sheet to the physician.

⚠ CAUTION**Risk of infection when working with wastewater!**

- ▶ Wear protective gloves, protective goggles and protective clothing.
- ▶ Observe applicable workplace safety regulations.
- ▶ In case of eye contact, rinse the affected area with plenty of water and then seek medical advice. Show the relevant safety data sheet to the physician.

NOTICE**Material damage due to solvents!**

- ▶ Do not use any halogen-containing organic solvents or acetone. These solvents could destroy plastic parts of the device.
- ▶ The Operating Instructions for the device must be observed before using solvents.

**Potential impact on the process**

Before decommissioning an active device, the potential impact on the overall process must be taken into account! This applies in particular when using the switching contacts, the analog signal outputs or the communication interface of the associated measuring instrument to control process variables. Coordinate service tasks with the operator!

5 Scope of delivery

5.1 71094033 Kit CYA112 O-rings for quick fastener

The kit contains the following parts → 1, 5:

1	1 x	O-ring ID 28.17 W 3.53 OD 35.23 mm EPDM	1 x	UNISILKON L 2 g lubricating grease
2	1 x	O-ring ID 32.5 W 3.6 OD 39.7 mm EPDM	1 x	Kit instructions

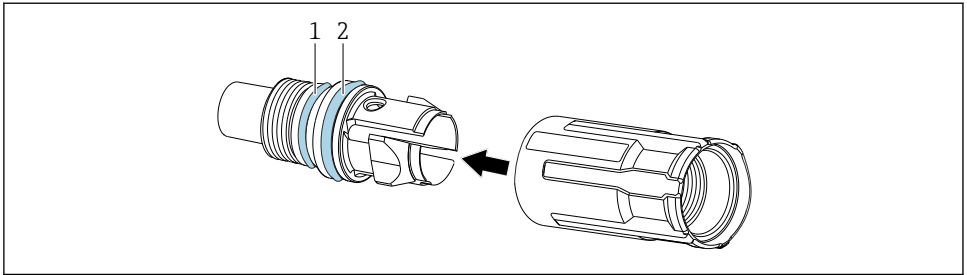

A0061976

☒ 1 *CYA112 O-rings for quick fastener*

5.2 71094034 Kit CYA112 O-rings for immersion tube

The kit contains the following parts → ☒ 2, 📄 5:

1	4 x	O-ring ID 33.05 W 1.78 OD 36.61 mm EPDM	1 x	UNISILKON L 2 g lubricating grease
2	1 x	O-ring ID 28.17 W 3.53 OD 35.23 mm EPDM	1 x	Kit instructions
3	1 x	O-ring ID 11.00 W 2.00 OD 15.00 mm EPDM		

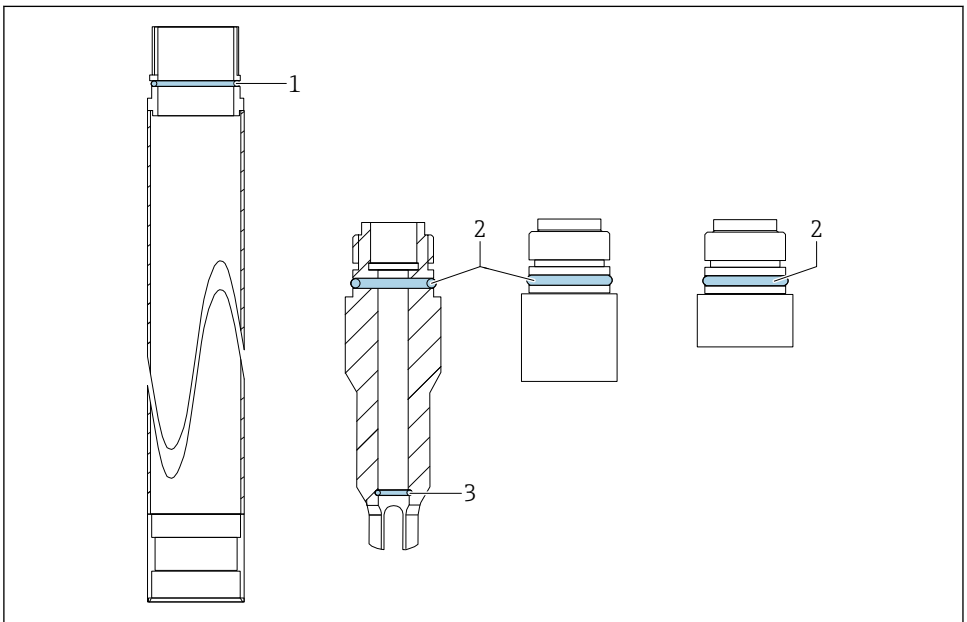

A0061977

☒ 2 *CYA112 O-rings for immersion tube*

6 Replacing the O-rings



The procedure for replacing components can be found in the relevant Operating Instructions. Before starting work, please observe the steps and safety instructions described in this documentation.

7 Additional documentation

Detailed information on the device can be found in the Operating Instructions for the assembly and in the other documentation available at:

- CYA112 product page: <https://www.endress.com/cya112>
- Spare parts finder: <https://sft-p.cdn.endress.com/>
- www.endress.com/device-viewer
- Smartphone/tablet: Endress+Hauser Operations app

8 Disposal



If required by the Directive 2012/19/EU on waste electrical and electronic equipment (WEEE), the product is marked with the depicted symbol in order to minimize the disposal of WEEE as unsorted municipal waste. Do not dispose of products bearing this marking as unsorted municipal waste. Instead, return them to the manufacturer for disposal under the applicable conditions.



71768717

www.addresses.endress.com
