



Level



Pressure



Flow



Temperature



Liquid
Analysis



Registration



Systems
Components



Services



Solutions

Safety Instructions

LPGmass

NEPSI Zone 1, Zone 21

Ex documentation

This document is an integral part of the following Operating Instructions:

- BA133D, LPGmass

Contents

General warnings	2
Installation instructions	2
COC certificates of conformity	3
Description of measuring system	3
Nameplate	4
Type code	5
Temperature table	5
Gas and dust explosion protection	6
Design of measuring system	6
Cable entries	6
Cable specification	6
Potential equalization	7
Electrical connection	8
Terminal assignment and connection data, power supply	8
Terminal assignment and connection data for signal circuits	9
Service adapter	9
Technical Data	9

General warnings

- For installation, use and maintenance of the flow meter, the instruction manual and the following standards shall be observed:
 - GB50257-1996 "Code for construction and acceptance of electric device for explosive atmospheres and fire hazard electrical equipment installation engineering"
 - GB3836.13-1997 "Electrical apparatus for explosive gas atmospheres – Part 13: Repair and overhaul for apparatus used in explosive gas atmospheres"
 - GB3836.15-2000 "Electrical apparatus for explosive gas atmospheres – Part 15: Electrical installations in hazardous area (other than mines)"
 - GB3836.16-2006 "Electrical apparatus for explosive gas atmospheres – Part 16: Inspection and maintenance of electrical installation (other than mines)"
 - GB15577-1995: Safety regulations for dust explosion prevention and protection". (Only if installed in dust hazardous areas.)
 - GB12476.2-2006 "Electrical apparatus for use in the presence combustible dust – Part 1-2: Electrical apparatus protected by enclosures and surface temperature limitation – selection, installation and maintenance" (only if installed in dust hazardous areas).
- Any maintenance shall be done after power off or the area known to be non-hazardous.
- The flow meter shall not be modified in order to ensure the explosion protection performance of the equipment. Any change may impair safety.
- Installation, connection to the electricity supply, commissioning and maintenance of the devices must be carried out by qualified specialists trained to work on Ex-rated devices.
- Compliance with all of the technical data of the device (see nameplate) is mandatory.
- Open the device only when it is de-energized (and after a delay of at least 10 minutes following shutdown of the power supply) or when the atmosphere is not potentially explosive [or in non-hazardous (classified) locations].
- It is not permissible to connect the service adapter whilst the atmosphere is considered to be explosive.
- Opening the transmitter housing is only permitted for a brief time. During this time, ensure that no dust or water enters the housing.
- To guarantee resistance to dust and water, the transmitter housing and the cable entries must be tightly sealed.
- Use of the devices is restricted to mediums against which the process-wetted materials are adequately resistant.
- The suitability of the device in the event of simultaneous occurrence of gas-air and dust-air mixtures requires an additional assessment.

Installation instructions

- The device must be integrated into the potential equalization system.
- For terminals No. 22 to No. 27 of the transmitter, only devices with ratings $U_m \leq 253 \text{ V}$ and $I_m \leq 1 \text{ A}$ are allowed to be connected.
- The measuring device must only be used in the permitted temperature class.
The values of the individual temperature classes can be found in the temperature tables on Page 5.
For Zone 21:
The surface temperature of the measuring device must not exceed $\frac{2}{3}$ of the ignition temperature of a dust cloud. The maximum surface temperature must maintain a safe distance of 75 °C to the smolder temperature of a dust layer of 5 mm.
Example:
Operation in temperature class T4 (135 °C) is, therefore, suitable for dust with an ignition temperature of 202.5 °C ($1.5 \times 135 \text{ °C}$ or $135 \text{ °C} = \frac{2}{3}$ of 202.5 °C) and a smolder temperature of 210 °C ($135 \text{ °C} + 75 \text{ °C}$).
- The following applies when using the terminal compartment in type of protection "flameproof/Ex d":
Only cable entries and cable glands, which are approved by NEPSI in accordance with GB3836.1-2000 and GB3836.2-2000 and which are suitable for an operating temperature of up to 80 °C , they shall be used.
- The following applies when using the terminal compartment in type of protection "increased safety/Ex e":
Only cable entries, cable glands and blanking plugs, which are approved by NEPSI in accordance with GB3836.1-2000 and GB3836.3-2000 and which are suitable for an operating temperature of up to 80 °C and for an ingress protection of IP 67, they shall be used. Alternatively Ex e cable glands specified or provided by Endress+Hauser Flowtec AG can be used. The cables must be installed in such a way, that they are fixed in place in order to ensure adequate strain relief.
- Suitable cables and suitable, certified cable glands, cable entries and blanking plugs must be used for measuring devices operated at temperatures below -20 °C .
- The cable entries and openings not used must be sealed tight with suitable components.

**Installation instructions
(continued)****Turning the transmitter housing**

The transmitter housing can be rotated counterclockwise continuously up to 360°.

1. Loosen the Allen setscrew (1) partially, but do not unscrew it all the way.
2. Rotate the transmitter housing into the desired position.
3. Tighten the Allen setscrew (1) properly after each manipulation.

⚠ Warning!

Ensure that the Allen setscrew is tightened properly.

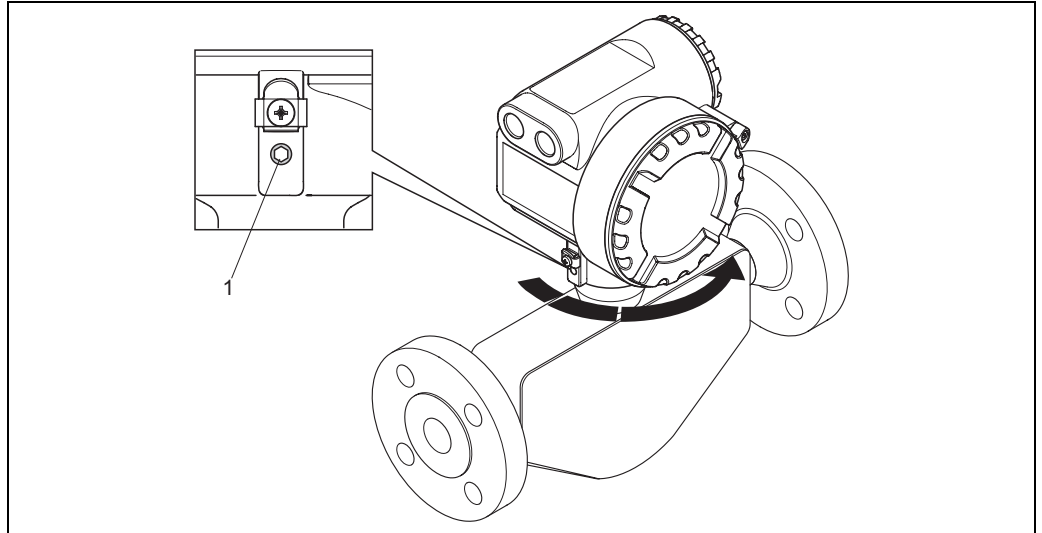

A0007884

Fig. 1: Turning the transmitter housing

**COC certificates of
conformity****COC certificates of conformity**

By affixing the certification number the product conforms with the following standards:

- GB3836.1 – 4 – 2000
- GB3836.9 – 2006
- GB12476.1 – 2000

Certification number:

- GYJ071290 (compact flow meter)

Inspection body

NEPSI, National Supervision and Inspection Centre for Explosion Protection and Safety of Instrumentation

**Description of measuring
system**

The measuring system consists of a transmitter and sensor which together form a mechanical unit.

Nameplate

The nameplate, which is mounted in a clearly visible position on the device, contains all of the relevant information about the measuring system.

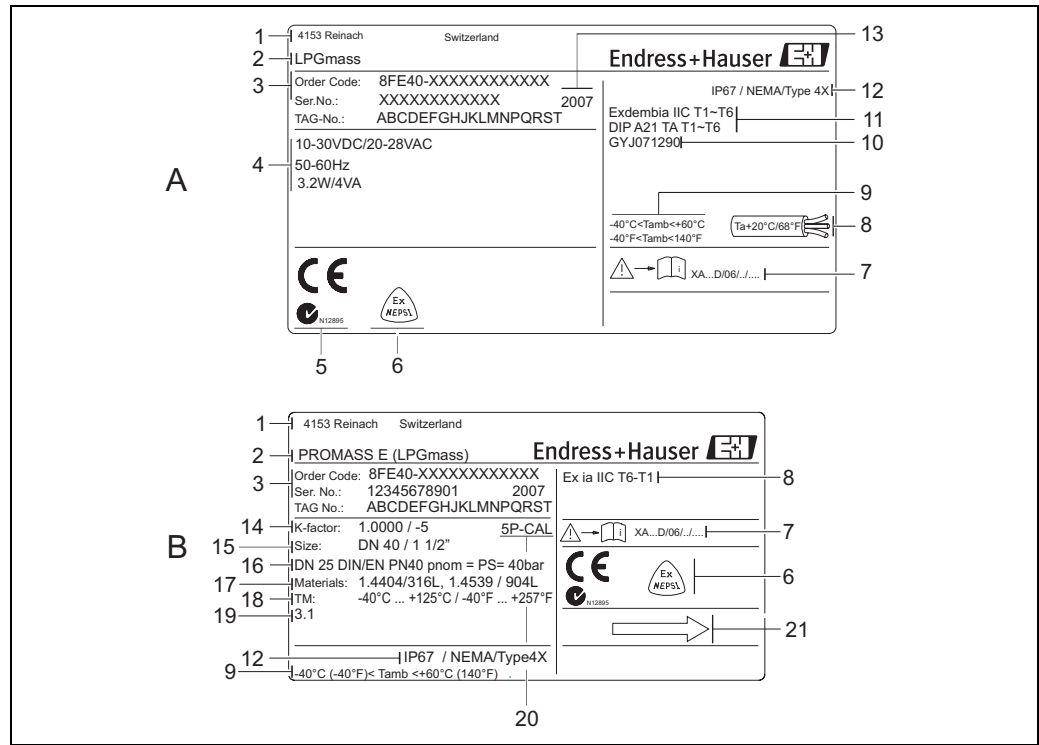

A0008259

Fig. 1: Example for nameplate

- A Transmitter nameplate
- B Sensor nameplate
- 1 Production site
- 2 Type of device
- 3 Order code and serial number
- 4 Power supply, frequency and power consumption
- 5 C-Tick symbol
- 6 NEPSI symbol
- 7 Associated Ex documentation
- 8 Maximum cable temperature
- 9 Ambient temperature range
- 10 Number of the NEPSI certificate of conformity
- 11 Type of protection
- 12 Ingress protection
- 13 Year of manufacture
- 14 Calibration factor/zero point
- 15 Device nominal diameter
- 16 Nominal diameter / process connection
- 17 Materials in contact with medium
- 18 Fluid temperature range
- 19 Additional specification e.g. 3.1 = 3.1 certificate for wetted materials
- 20 5-point calibration
- 21 Direction of flow

Type code

The type code describes the exact design and the equipment of the measuring system. It can be read on the nameplate of the transmitter and sensor and is structured as follows:

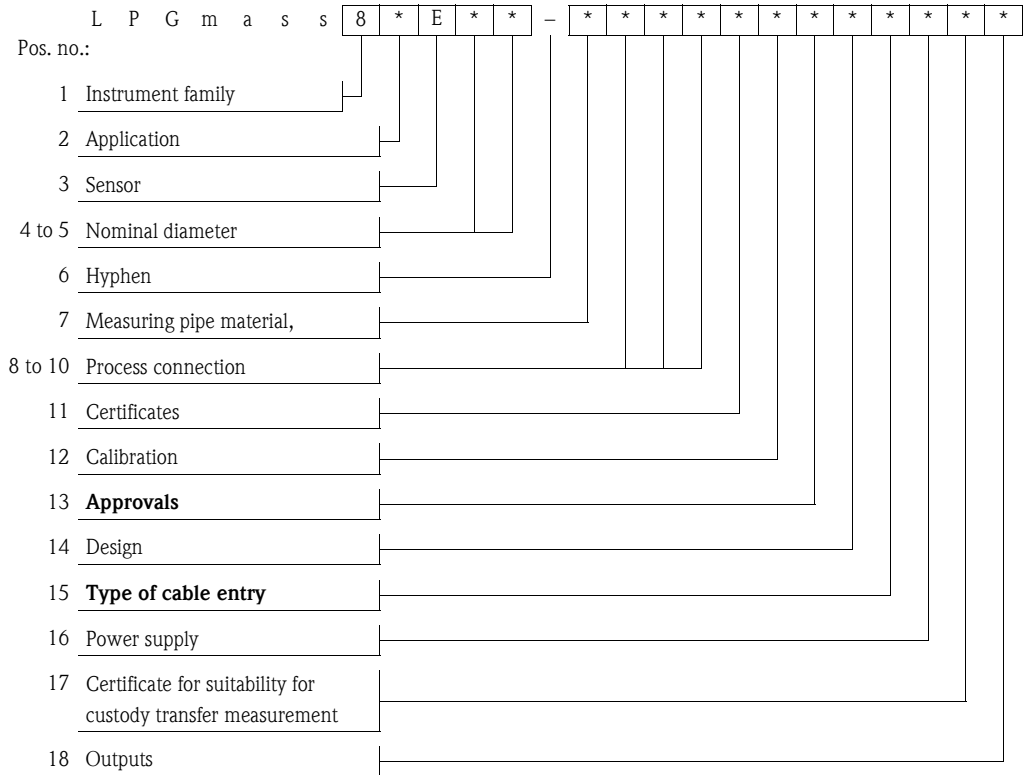

Approvals (Item No. 13 in type code)

*	Type of explosion protection	
	Transmitter	Sensor
K	Ex dia IIC T1 ~ T6 DIP A21 T _A , T1 ~ T6	Ex ia IIC T1 ~ T6 DIP A21 T _A , T1 ~ T6
L	Ex dembia IIC T1 ~ T6 DIP A21 T _A , T1 ~ T6	Ex ia IIC T1 ~ T6 DIP A21 T _A , T1 ~ T6

Type of cable entry (Item No. 15 in type code)

*	Thread form
0	Without gland, M20x1.5 thread
A	M20x1.5 cable gland for approval "L", M20x1.5 thread for approval "K"
B	1/2" – 14 NPT
C	G 1/2"

Temperature table

Max. medium temperature [°C] for T1 ~ T6 in relation to the maximum ambient temperature T_a

	DN	T _a	T6 (85 °C)	T5 (100 °C)	T4 (135 °C)	T3 (200 °C)	T2 (300 °C)	T1 (450 °C)
LPGmass 8FE**-*-*-*-*-*-*-*	DN 8...15	+45 °C	45	95	125	125	125	125
	DN 8...15	+50 °C	–	95	125	125	125	125
	DN 25...40		50	95	125	125	125	125
	DN 8...40	+60 °C	–	95	125	125	125	125

The minimum **medium temperature** is –40 °C for LPGmass.

The minimum **ambient temperature** T_a for LPGmass is –40 °C.

Gas and dust explosion protection

Determine the temperature class for gas in relation to the ambient T_a and medium temperature T_M
 Determine the maximum surface temperature for dust in relation to the max. ambient temperature T_a and max. medium temperature T_M

Example

Device: LPGmass, DN 25
 Max. ambient temperature: $T_a = 60\text{ °C}$
 Max. medium temperature: $T_M = 98\text{ °C}$

	DN	T_a	T6 (85 °C)	T5 (100 °C)	T4 (135 °C)	T3 (200 °C)	T2 (300 °C)	T1 (450 °C)
LPGmass 8FE**.....	DN 8...15	+45 °C	45	95	125	125	125	125
	DN 8...15	+50 °C	—	95	125	125	125	125
	DN 25...40		50	95	125	125	125	125
	DN 8...40	+60 °C	—	—	125	125	125	125

DN 25 $T_a \text{ max} = 60\text{ °C}$ $T_M = 98\text{ °C} (\leq 125\text{ °C})$

A0008260

Fig. 2: Procedure for calculating the max. surface temperature

1. In the associated temperature table, the ambient temperature T_a (60 °C) determine the line in which the max. medium temperature can be found.
2. The max. medium temperature T_M (98 °C), which is \leq the max. medium temperature of a cell, determines the column, or temperature class, for gas (98 °C \leq 125 °C \rightarrow T4).
3. The maximum temperature of the calculated temperature class corresponds to the maximum surface temperature (T4 = 135 °C = maximum surface temperature for dust).

Design of measuring system

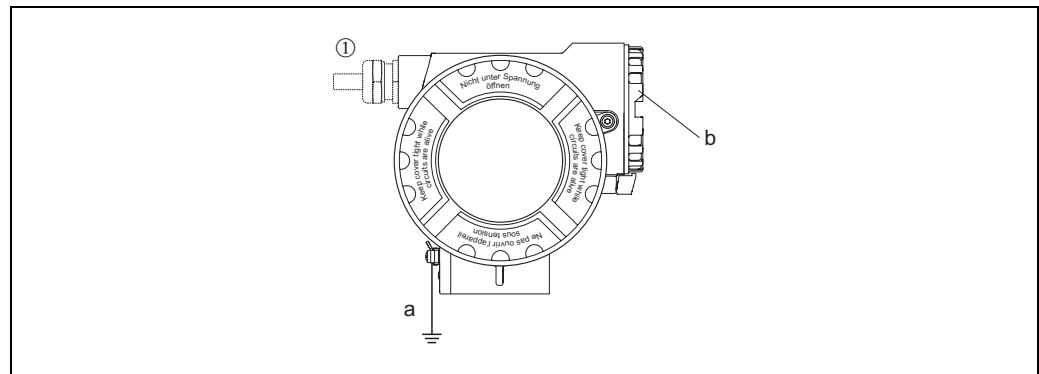

A0008258

Fig. 3: Design of the transmitter

- a Screw terminal for connecting to the potential equalization
- b Connection compartment cover
- ① see following section "Cable entries"

Cable entries

- ① for connection compartment (Ex d version): power supply cable and cable of the communication circuit \rightarrow Choice of thread for cable entries M20x1.5, 1/2" NPT or G 1/2".
 Make sure that the Ex d cable glands/entries are secured to prevent working loose and that the seals are installed immediately adjacent to the housing.
- ① for connection compartment (Ex e version): power supply cable and cable of the communication circuit \rightarrow Choice of cable gland M20x1.5 or thread for cable entries 1/2" NPT or G 1/2".
 The cables must be installed such that they are fixed in place. Adequate strain relief must be ensured.

Warning!

The leak-tight of the cable glands and cable entries is to ensure.

Cable specification

You can find information about the cable specification in the associated Operating Instructions.

Potential equalization

The transmitter is to be securely connected to the potential equalization system using the screw terminal on the outside of the transmitter housing. Alternatively, the transmitter of the compact version can be connected to the potential equalization system via the pipeline if a ground connection via the pipeline according to regulations can be assured.

 Note!

Further information about potential equalization, shielding and grounding can be found in the associated Operating Instructions.

Potential equalization with shield grounded at both sides for MODBUS version

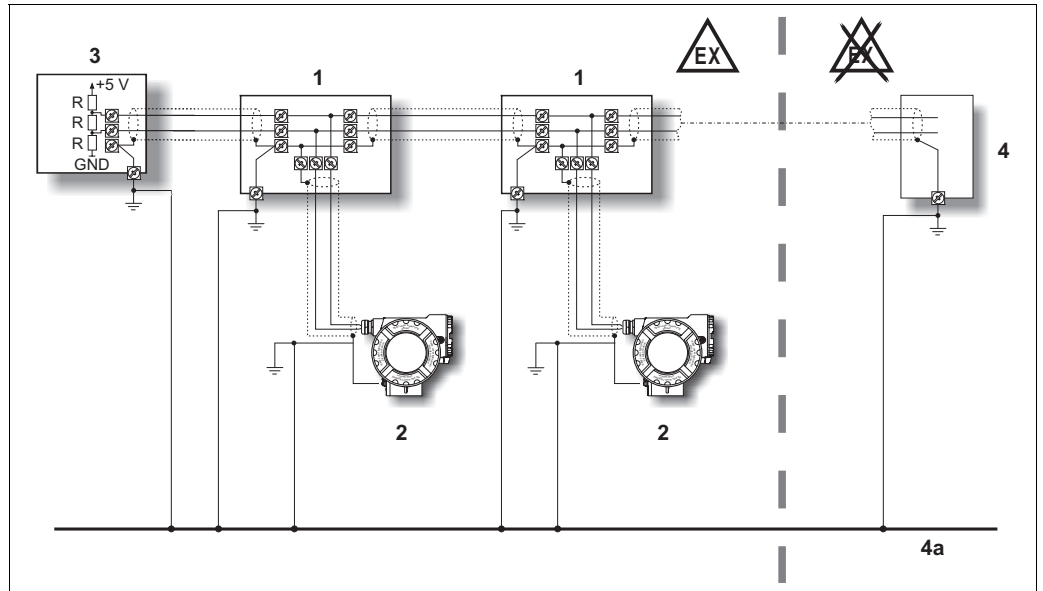

Fig. 4: Example for connecting potential equalization lines

- 1 Distributor/T-Box
- 2 Bus devices for potentially explosive atmospheres
- 3 Bus terminator MODBUS
- 4 Bus supply unit or automation system
- 3a Potential equalization line is fed out into the safe area

 Note!

The length of the spur must be observed.

Electrical connection

Connection compartment

Transmitter housing (terminal assignment, connection data → Page 8 ff.)

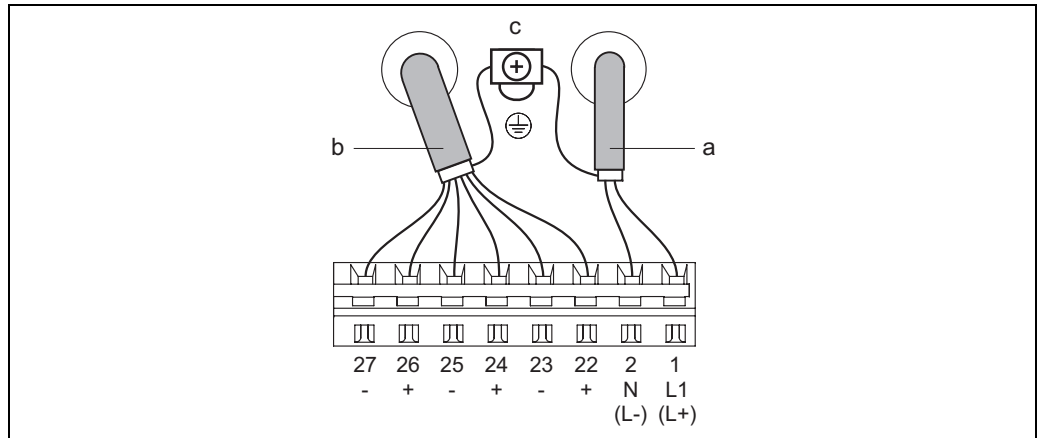

A0007034

Fig. 5: Electrical connection

- a Power supply cable (terminal assignment and connection data see below)
- b Signal cable / RS485 line (terminal assignment and connection data → Page 8)
- c Ground terminal for protective ground, signal cable shield, RS485 line

Terminal assignment and connection data, power supply

Terminal assignment and connection data

All transmitters	1 L (+)	2 N (-)	⊕
Designation	Supply voltage		Protective earth
Functional values	AC: U = 20 to 28 V DC: U = 10 to 30 V Power consumption: AC: < 4 VA DC: < 3.2 W		Caution! Observe the grounding plans of the system!
Intrinsically safe circuit	no		
U _m	253 V AC		

Terminal assignment and connection data for signal circuits

 Note!

The following tables contain values/specifications, which are dependent on the type code (type of measuring device). Please compare the following type code to the one shown on the nameplate of your measuring device. A graphic representation of the electrical connections can be found on Page 8.

Terminal assignment

Transmitter	Terminal no. (outputs)					
	22 (+)	23 (-)	24 (+)	25 (-)	26 (+)	27 (-)
<i>Non-convertible communication boards (fixed assignment)</i>						
8FE**- *...*N	Pulse / Frequency / Status output 2		Pulse / Frequency / Status output 1		MODBUS RS485* B A	
* PROFIBUS DP, MODBUS RS485: – Terminal 26 (+) → B (RxD/TxD-P) – Terminal 27 (-) → A (RxD/TxD-N)						

Safety-related and functional values of signal circuits

Signal circuits	Functional values	Safety-related values
Pulse/frequency output	galvanically isolated passive 30 V DC / 250 mA Open Collector Full scale frequency 100 to 5000 Hz	intrinsically safe = no U_m = 253 V I_m = 1 A
Status output	galvanically isolated passive 30 V DC / 250 mA Open Collector	
MODBUS RS485	galvanically isolated, RS485 as per Standard EIA/TIA-485	

Service adapter

The service adapter is only used for connecting service interfaces approved by Endress+Hauser (e.g. FXA291).

 Warning!

It is not permissible to connect the service adapter whilst the atmosphere is considered to be explosive.

Technical Data

Dimensions

The dimensions of the instruments for the hazardous area correspond to those in the Technical Information documentation.

Weight

The weight of the Ex d version is equivalent to the weight in the Technical Information documentation.

 Note!

Technical Information for LPGmass → TI080D

www.endress.com/worldwide

Endress+Hauser 
People for Process Automation