

Technical Information

Prosonic S FDU91

Ultrasonic measuring technology



Ultrasonic sensor for level measurement and flow measurement

Application

- Continuous, non-contact level measurement of liquids and bulk solids in silos, on conveyor belts, in material stockpiles and in crushers
- Flow measurement in open flumes and measuring weirs
- Maximum measuring range: 10 m (33 ft) in liquids; 5 m (16 ft) in bulk solids

Your benefits

- Integrated temperature sensor for time-of-flight correction, enabling accurate measurements even if temperatures change
- Hermetically welded PVDF sensor for maximum chemical resistance
- Suitable for harsh ambient conditions thanks to separate transmitter installation (up to 300 m (984 ft))
- Self-cleaning effect ensures minimum deposit build-up
- Weather resistant and flood-proof (IP68)
- International Dust-Ex and Gas-Ex certificates available

Table of contents

Important document information	3	Ordering information	15
Document conventions	3	Ordering information	15
Function and system design	4	5-point linearity protocol	15
Level measurement	4	Scope of delivery	16
Flow measurement in flumes or weirs	4	Accessories	16
Temperature-dependent time-of-flight correction	5	Sensor extension cable	16
Input	5	Weather protection cover	16
Blocking distance	5	Screw-in flange FAX50	16
Measuring range	5	Cantilever arm for the sensors	17
Operating frequency	6	Mounting bracket for ceiling mounting	20
Power supply	6	FAU40 alignment unit	20
Supply voltage	6	RNB130 power supply unit for the sensor heater	21
Power supply to integrated sensor heater	6	IP66 protective housing for RNB130 power supply unit	22
Electrical connection	6	Supplementary documentation	22
Connection diagram for sensor → FMU90	7	Documentation for FMU90 transmitter	22
Connection diagram for sensor → FMU95	7	Documentation for FMU95 transmitter	22
Extension cable specifications	7	Other documentation	22
Shortening the sensor cable	8		
Installation	8		
Installation conditions for level measurement	8		
Installation conditions for flow measurement	9		
Installation instructions	10		
Installation options (examples)	10		
Nozzle mounting	11		
Ultrasound guide pipe for measurement in narrow pits	12		
Securing the sensor	12		
Environment	12		
Degree of protection	12		
Vibration resistance	12		
Storage temperature	12		
Thermal shock resistance	12		
Electromagnetic compatibility	12		
Process	13		
Process temperature	13		
Process pressure	13		
Mechanical construction	13		
Dimensions	13		
Dimensions of G1" counter nut	13		
Weight	13		
Materials	14		
Materials of connecting cable	14		
Material of G1" counter nut	14		
Certificates and approvals	14		
CE mark	14		
RoHS	14		
RCM-Tick marking	14		
Ex approval	14		
Other standards and guidelines	14		

Important document information

Document conventions

Safety symbols

 **DANGER**

This symbol alerts you to a dangerous situation. Failure to avoid this situation will result in serious or fatal injury.

 **WARNING**

This symbol alerts you to a dangerous situation. Failure to avoid this situation can result in serious or fatal injury.

 **CAUTION**

This symbol alerts you to a dangerous situation. Failure to avoid this situation can result in minor or medium injury.

 **NOTICE**

This symbol contains information on procedures and other facts which do not result in personal injury.

Electrical symbols



Ground connection

A grounded terminal which, as far as the operator is concerned, is grounded via a grounding system.

Tool symbols



Open-ended wrench

Symbols for certain types of information and graphics

 **Permitted**

Procedures, processes or actions that are permitted

 **Forbidden**

Procedures, processes or actions that are forbidden

 **Tip**

Indicates additional information



Reference to documentation

 **1, 2, 3**

Series of steps

1, 2, 3, ...

Item numbers

A, B, C, ...

Views

Function and system design

Level measurement

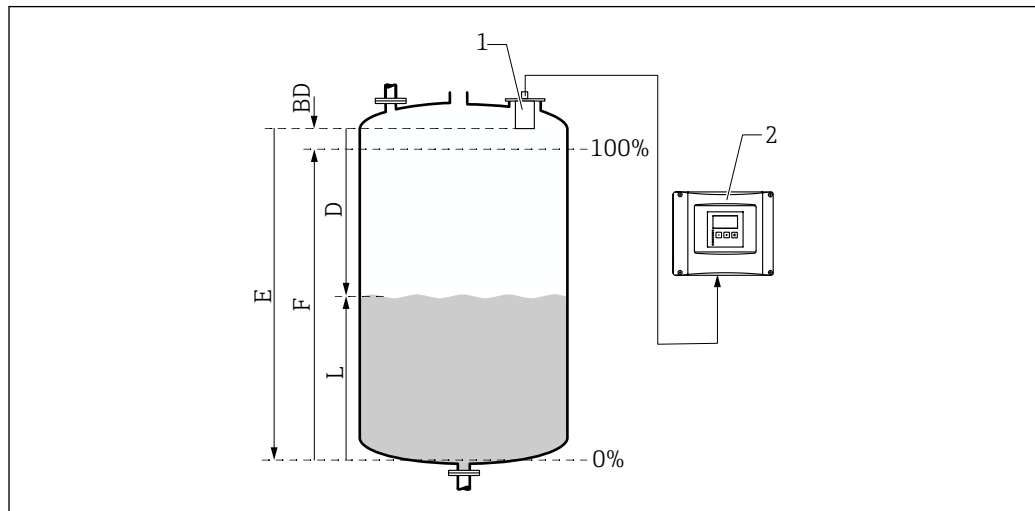

A0034882

- 1 Prosonic S sensor
- 2 Prosonic S transmitter
- BD Blocking distance
- D Distance between reference point (sensor membrane) and surface of medium
- E Empty distance
- F Span
- L Level

The sensor transmits ultrasonic pulses in the direction of the surface of the medium. There, they are reflected back and received by the sensor. The transmitter measures the time t between the transmission and reception of a pulse. From this time, and using the sonic velocity c , the transmitter calculates the distance D between the reference point (sensor membrane) and the surface of the medium:

$$D = c \cdot t / 2$$

The level L is derived from D . With linearization, the volume V or the mass M is derived from L .

Flow measurement in flumes or weirs

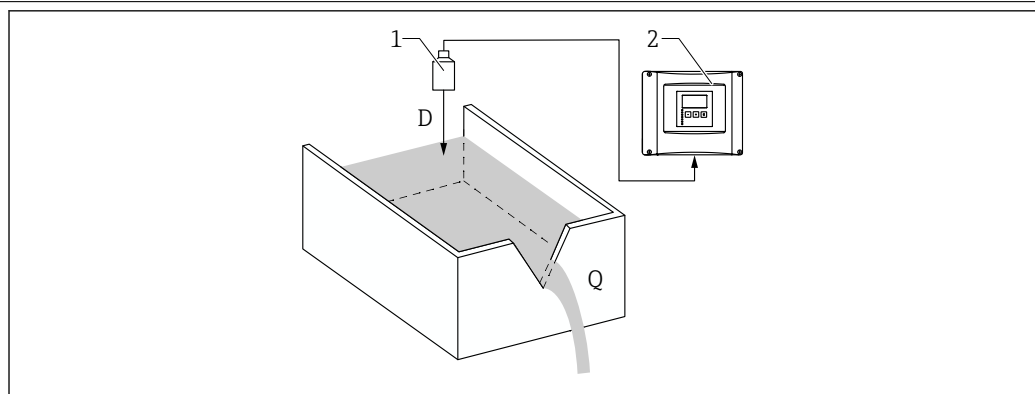

A0035219

- 1 Prosonic S sensor
- 2 Prosonic S transmitter
- D Distance between sensor membrane and surface of liquid
- Q Flow

The sensor transmits ultrasonic pulses in the direction of the surface of the liquid. There, they are reflected back and received by the sensor. The transmitter measures the time t between the transmission and reception of a pulse. From this time, and using the sonic velocity c , the transmitter calculates the distance D between the (reference point) sensor membrane and the surface of the liquid:

$$D = c \times t / 2$$

The level L is derived from D. With linearization, the flow Q is derived from L.

Temperature-dependent time-of-flight correction

Temperature-dependent time-of-flight correction via an external temperature sensor, to be connected to the FMU90 transmitter.

Input

Blocking distance

Signals within the blocking distance (BD) range cannot be measured due to the transient response of the sensor.

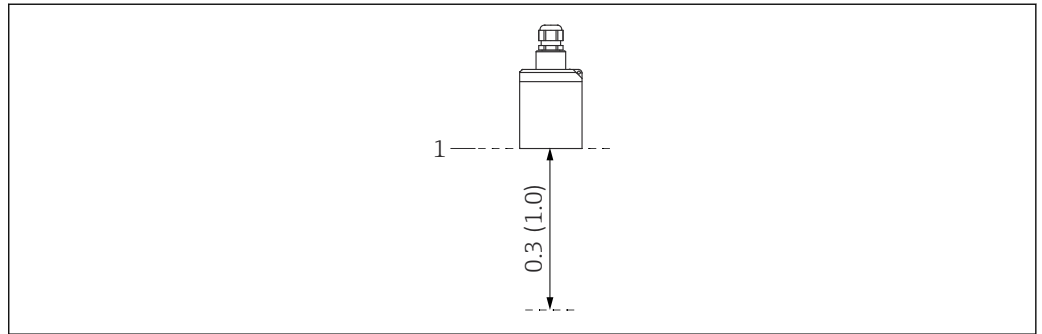

1 Blocking distance of the ultrasonic sensor. Engineering unit m (ft)

1 Reference point (sensor membrane) of measurement

Measuring range

Estimation of the effective sensor range depending on the operating conditions

1. Add up all the applicable attenuation values from the following lists.
2. From the total calculated attenuation, use the range chart below to calculate the range of the sensor.

Attenuation caused by surface of liquid

- Calm surface: 0 dB
- Waves on surface: 5 to 10 dB
- Very turbulent surface: 10 to 20 dB
- Frothy surface: contact Endress+Hauser: <http://www.endress.com/contact>

Attenuation due to bulk solids surface

- Hard, rough surface (e.g. rubble): 40 dB
- Soft surface (e.g. peat, dust-covered clinker): 40 to 60 dB

Attenuation due to dust

- No dust formation: 0 dB
- Minor dust formation: 5 dB
- Major dust formation: 5 to 20 dB

Attenuation caused by filling curtain in detection range

- No filling curtain: 0 dB
- Small volumes: 5 dB
- Large volumes: 5 to 20 dB

Attenuation caused by temperature difference between sensor and product surface

- Up to 20 °C (68 °F): 0 dB
- Up to 40 °C (104 °F): 5 to 10 dB
- Up to 80 °C (176 °F): 10 to 20 dB



A0039797

2 Range chart for ultrasonic sensors

A Total attenuation in dB
R Range in m (ft)

Operating frequency 43 kHz

Power supply

Supply voltage Is provided by the transmitter.

Power supply to integrated sensor heater **Device versions with sensor heater**
FDU91-***B*

Connection data

- Supply voltage: $24 V_{DC} \pm 10\%$
- Residual ripple: $< 100\text{ mV}$
- Current consumption: 250 mA per sensor
- Suitable power supply unit: RNB130 from Endress+Hauser

- i** When the sensor heater is active, the integrated temperature sensor cannot be used. Instead, use one of the following external temperature sensors:
- Pt100
 - Omnigrad S TR61 from Endress+Hauser
 - For information on connecting the external temperature sensor, see Technical Information TI00397F.

Electrical connection **General information**

NOTICE

Interference signals may cause malfunctions

- ▶ Do not route the sensor cables parallel to high-voltage electric power lines or near frequency converters.

NOTICE

A damaged cable shield may cause malfunctions

- ▶ For pre-terminated cables: connect the black wire (shield) to the "BK" terminal.
- ▶ For extension cables: twist the shield and connect to the "BK" terminal.

Connection diagram for sensor → FMU90

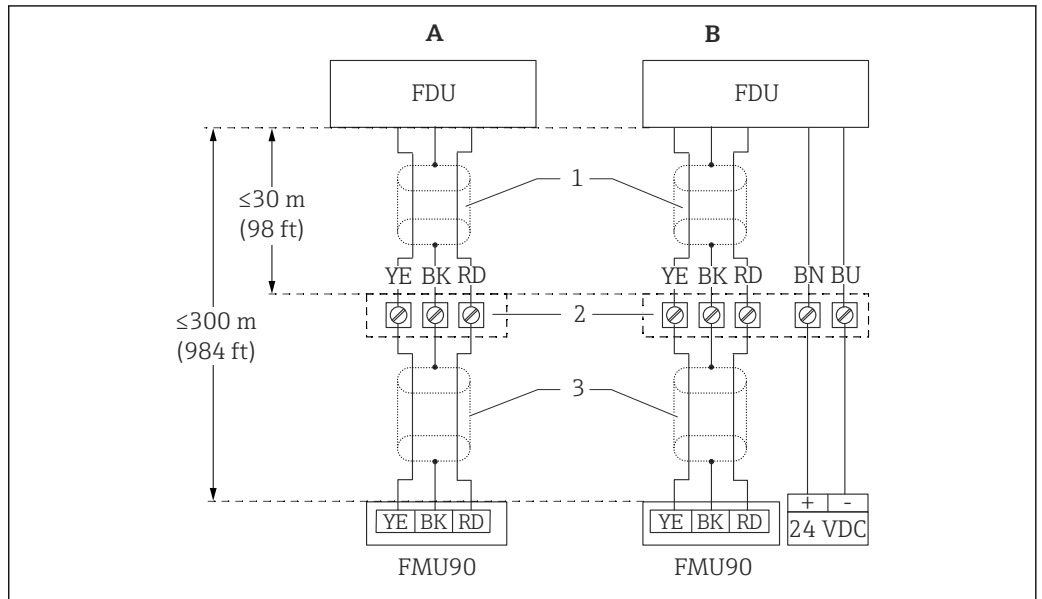

A0039801

3 Connection diagram for sensor; YE: yellow, BK: black; RD: red; BU: blue; BN: brown; protective conductor GNYE: green/yellow

- A Without sensor heater
- B With sensor heater
- 1 Shielding of sensor cable
- 2 Terminal box
- 3 Shielding of extension cable

Connection diagram for sensor → FMU95

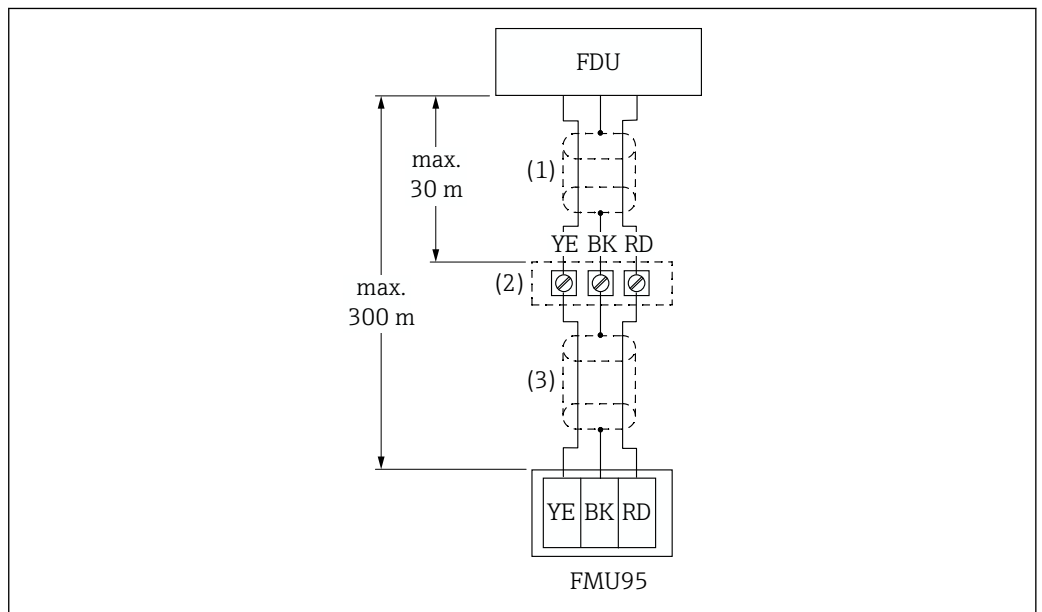

A0039804

4 Connection diagram for sensor; YE: yellow, BK: black; RD: red; BU: blue; BN: brown; protective conductor GNYE: green/yellow

- 1 Shielding of sensor cable
- 2 Terminal box
- 3 Shielding of extension cable

Extension cable specifications

- **Maximum total length (sensor cable + extension cable)**
300 m (984 ft)
- **Number of wires**
As per connection diagram
- **Shielding**
One shielding braid for the YE wire and one for the RD wire (no foil shield)

- **Cross-section**
0.75 to 2.5 mm² (18 to 14 AWG)
- **Resistance**
Max. 8 Ω per wire
- **Capacitance, wire to shield**
Max. 60 nF

 Suitable extension cables are available from Endress+Hauser.

Shortening the sensor cable

The sensor cable can be shortened if necessary (see the Operating Instructions for the FMU90 or FMU95 transmitter).

Installation

Installation conditions for level measurement

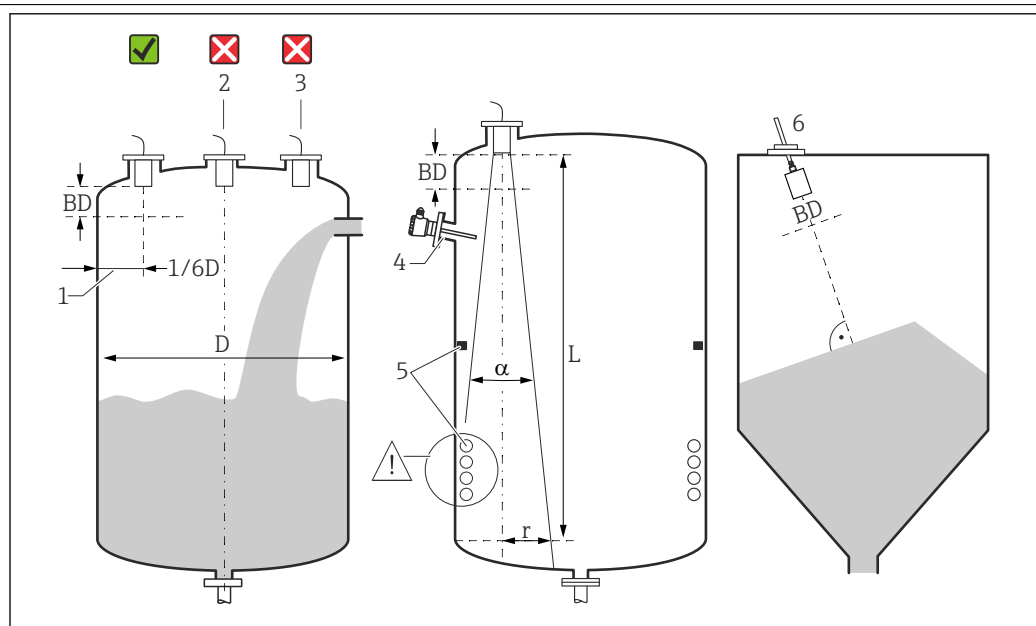

 5 Installation conditions for level measurement

- 1 Recommended distance to the vessel wall; 1/6 of the vessel diameter D .
 - 2 Do not mount in the center of the vessel.
 - 3 Avoid measurements through the filling curtain.
 - 4 There must be no internal fixtures in the signal beam.
 - 5 Symmetrical internal fixtures, in particular, negatively impact the measurement.
 - 6 For bulk solids: using the FAU40 alignment unit, align the sensor so that it is perpendicular to the surface of the product.
- BD Blocking distance

Emitting angle/beam

- α (typical) = 9°
- L (max) = 10 m (33 ft)
- r (max) = 0.79 m (2.6 ft)

Other conditions

- The lower edge of the sensor should be located inside the vessel
- The maximum level may not enter the blocking distance

Several sensors in one vessel

Sensors that are connected to a common FMU90 or FMU95 transmitter can be used in one vessel.

Installation conditions for flow measurement

Conditions

- Mount the sensor on the upstream side above the maximum upstream level H_{max} plus the blocking distance BD
- Position the sensor in the center of the channel or weir
- Align the sensor so that it is perpendicular to the surface of the water
- Observe the specified mounting distance (clearance) to the flume constriction or weir edge
See the Operating Instructions for FMU90 / FMU95
- Protect the sensor against sun and precipitation using the weather protection cover

Example: Khafagi-Venturi flume

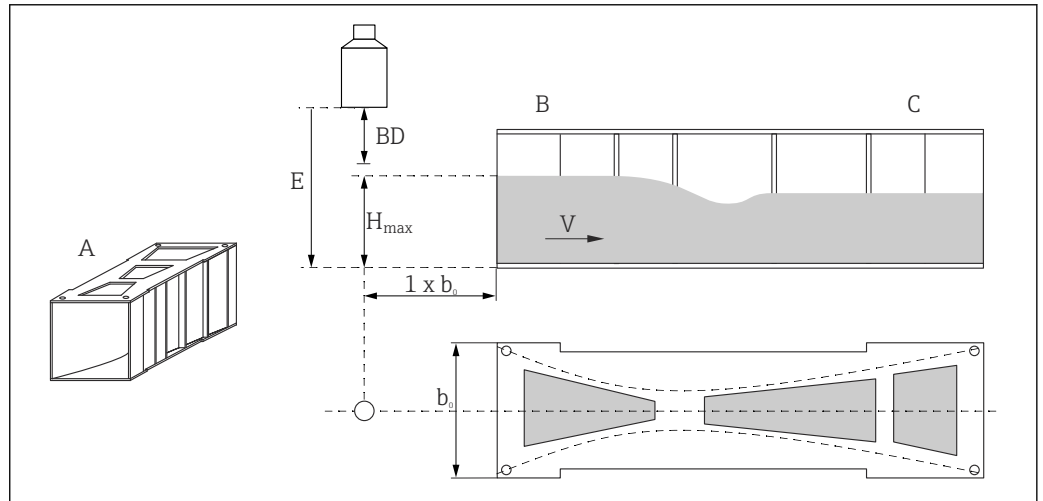

A0036744

- A Khafagi-Venturi flume
- b_0 Width of Khafagi-Venturi flume
- B Upstream side
- C Downstream side
- BD Blocking distance of the sensor
- E Empty calibration (to be entered during commissioning)
- H_{max} Maximum upstream level
- V Flow

Example: Triangular weir

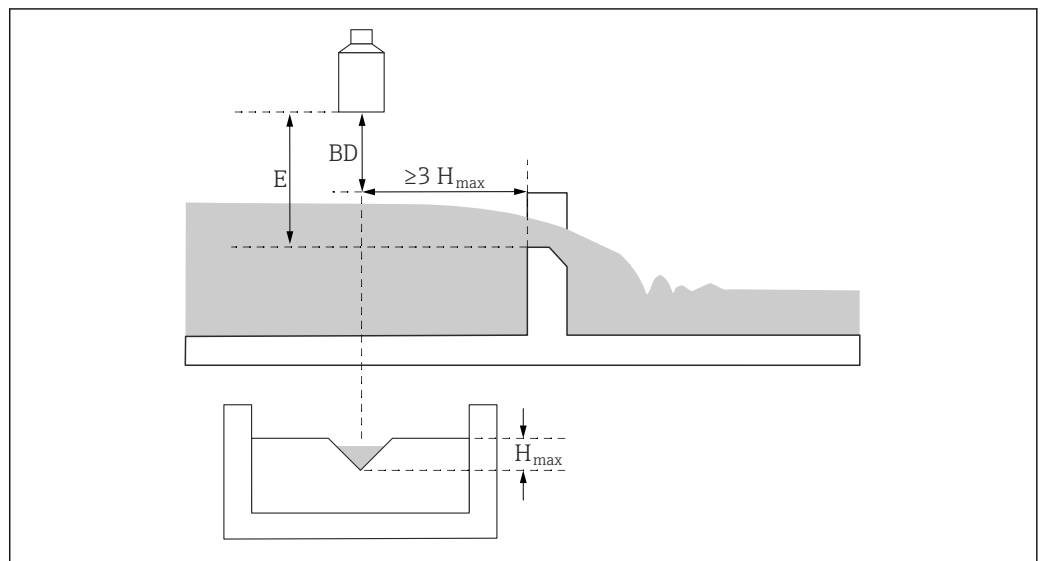

A0036745

- BD Blocking distance of the sensor
- E Empty calibration (to be entered during commissioning)
- H_{max} Maximum upstream level

Installation instructions

Removing the cable transportation guard

In the case of devices with a rear-side process connection "FNPT1/2 conduit", the cable protective plug must be removed before installation.

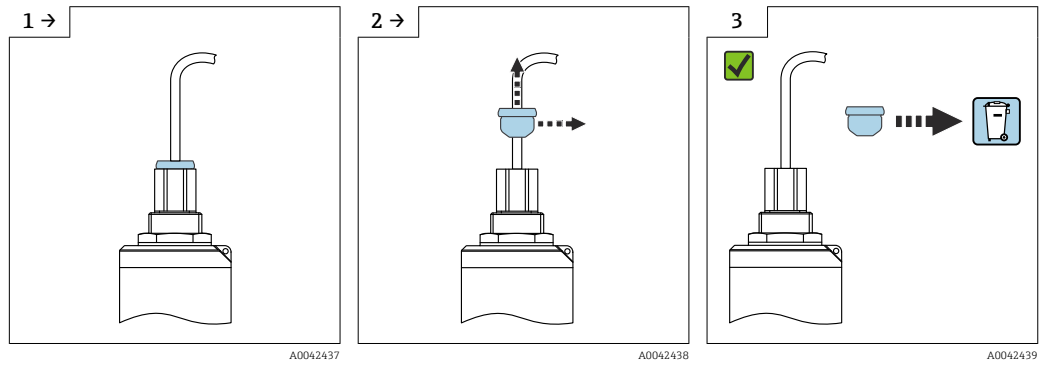

Installation options (examples)

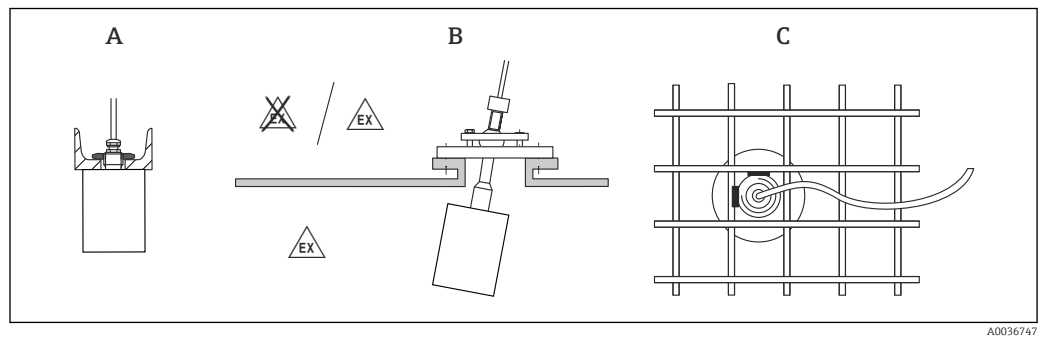

6 Installation in systems

- A On U-rail or bracket
- B With FAU40 alignment unit
- C With 1" sleeve welded to a grating

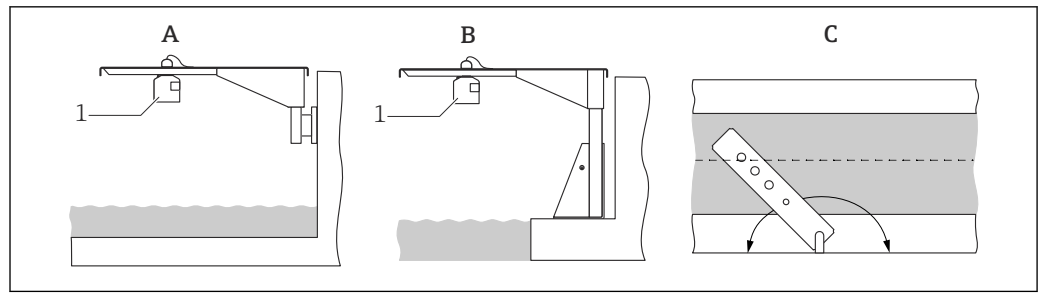

7 Installation with cantilever arm over open channels or flumes

- A Arm with wall bracket
- B Cantilever with mounting frame
- C The arm can be turned (e.g. to position the sensor over the center of the channel)

Nozzle mounting

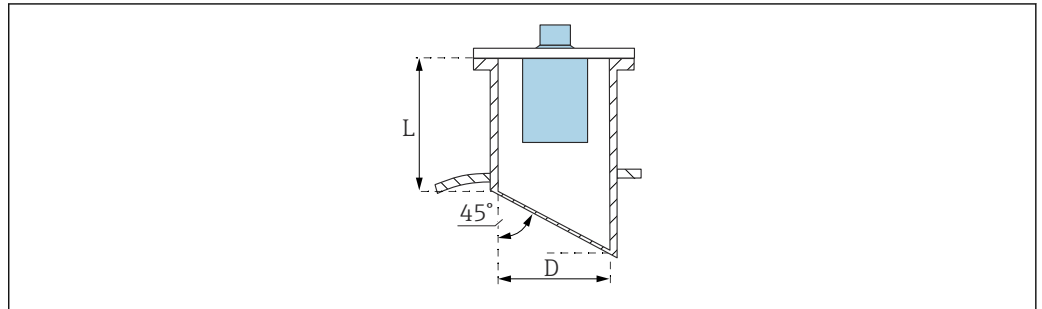

A0039840

D Nozzle diameter
L Nozzle length

Conditions at the nozzle

- Smooth interior, without edges or welds
- No burr on the inside of the nozzle end on the tank side
- Beveled nozzle end on tank side (ideally: 45 °)

Maximum nozzle length

- $D = \text{DN}80/3''$: $L_{\text{max}} = 340 \text{ mm (13.4 in)}$
- $D = \text{DN}100/4''$: $L_{\text{max}} = 390 \text{ mm (15.4 in)}$
- $D = \text{DN}150/6''$ to $\text{DN}300/12''$: $L_{\text{max}} = 400 \text{ mm (15.7 in)}$

Ultrasound guide pipe for measurement in narrow pits

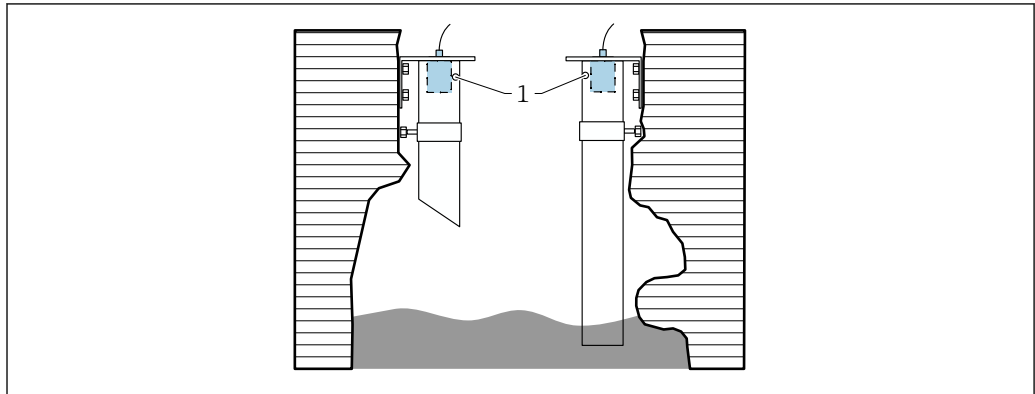

A0036695

1 Venting hole

- Suitable ultrasound guide pipe: e.g. PE or PVC wastewater pipe
- Minimum diameter: DN100
- Venting hole at top
- No contamination from built-up dirt (clean regularly where necessary)

Securing the sensor

NOTICE

Risk of damage to the sensor

- ▶ Do not use the sensor cable for suspension purposes.
- ▶ Do not damage the sensor membrane when installing.

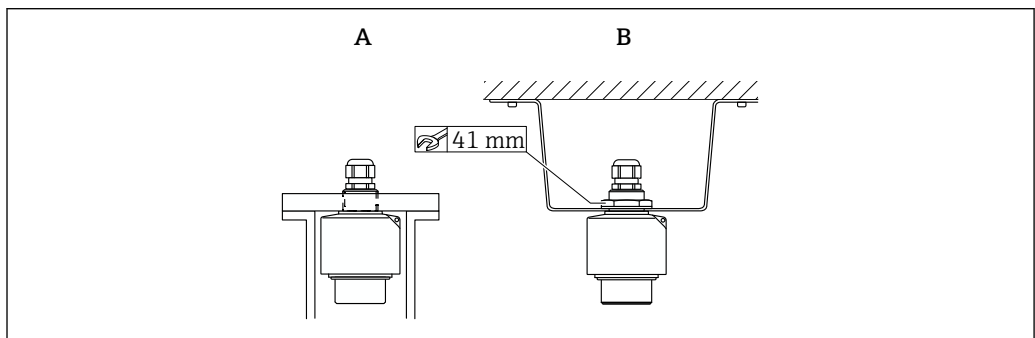

A0039841

8 Securing the ultrasonic sensor

A Mounted at rear thread

B Mounted with counter nut

Environment

Degree of protection	Tested according to IP68/NEMA6P (24 h at 1.83 m (6 ft) under water)
Vibration resistance	DIN EN 600068-2-64; 20 to 2000 Hz; 1 (m/s ²) ² /Hz; 3x100 min
Storage temperature	Identical to process temperature
Thermal shock resistance	Based on DIN EN 60068-2-14; test according to min./max. process temperature; 0.5 K/min; 1000 h
Electromagnetic compatibility	Electromagnetic compatibility in accordance with all the relevant requirements outlined in the EN 61326 series and NAMUR Recommendation EMC (NE 21). For details, refer to the Declaration of Conformity. With regard to interference emission, the devices meet the requirements of class A, and are only designed for use in an "industrial environment".

Process

Process temperature	-40 to +80 °C (-40 to +176 °F) To prevent the build-up of ice on the sensor, the sensors are available in a version with integrated sensor heating.
Process pressure	0.7 to 4 bar (10.15 to 58 psi)

Mechanical construction

Dimensions

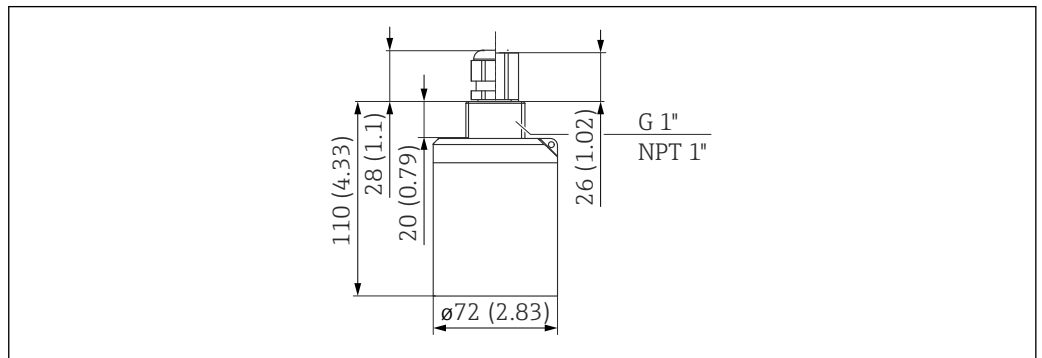

9 Dimensions. Unit of measurement mm (in)

Dimensions of G1" counter nut

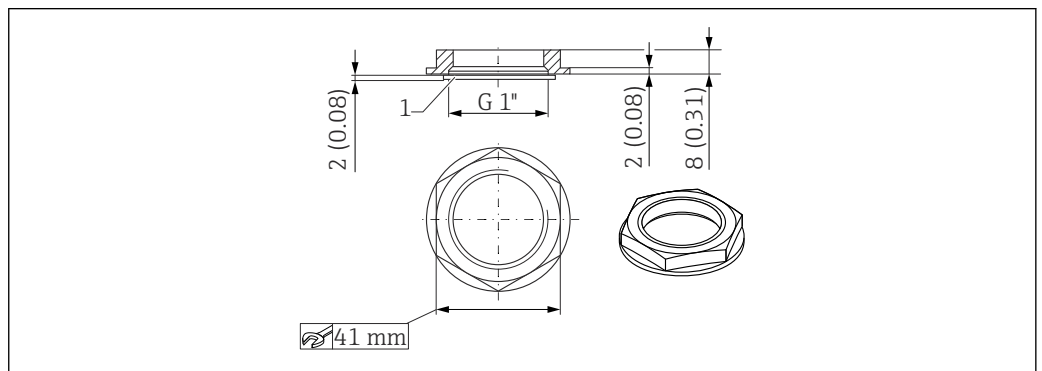

10 Counter nut; dimensions. Unit of measurement mm (in)

- i** The counter nut is included in the delivery for the following sensors:
 - FDU91-*G*** (rear G1 thread)
 - The counter nut is not suitable for NPT threads.

Weight	Weight including cable 5 m (16 ft) Approx. 1.1 kg (2.43 lb)
---------------	--

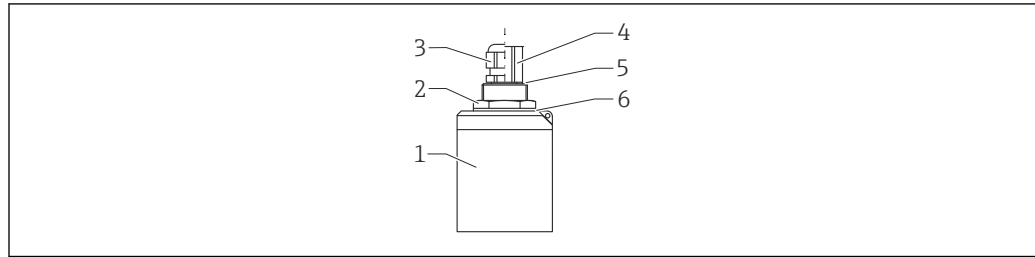
Materials

A0038715

 **11 Materials**

- 1 Sensor housing: PVDF
- 2 Counter nut: PA6.6
- 3 Cable gland: PA
- 4 Pipe adapter: CuZn nickel-plated
- 5 O-ring: EPDM
- 6 Seal: EPDM

Materials of connecting cable PVC

Material of G1" counter nut

- Counter nut: PA6.6
- Seal (included in the delivery): EPDM

Certificates and approvals

CE mark The measuring system meets the legal requirements of the applicable EU Directives. These are listed in the corresponding EU Declaration of Conformity along with the standards applied.
Endress+Hauser confirms successful testing of the device by affixing to it the CE mark.

RoHS The measuring system complies with the substance restrictions of the Restriction on Hazardous Substances Directive 2011/65/EU (RoHS 2).

RCM-Tick marking The supplied product or measuring system meets the ACMA (Australian Communications and Media Authority) requirements for network integrity, interoperability, performance characteristics as well as health and safety regulations. Here, especially the regulatory arrangements for electromagnetic compatibility are met. The products are labelled with the RCM-Tick marking on the name plate.



A0029561

Ex approval Available Ex approvals: see Product Configurator

 Sensors with an Ex approval can be connected to the FMU90 transmitter without an Ex approval.

Other standards and guidelines

EN 60529

Degrees of protection provided by enclosures (IP code)

EN 61326 series

EMC product family standard for electrical equipment for measurement, control and laboratory use

NAMUR

User association of automation technology in process industries

Ordering information

Ordering information

Detailed ordering information is available for your nearest sales organization www.addresses.endress.com or in the Product Configurator under www.endress.com

1. Click Corporate
2. Select the country
3. Click Products
4. Select the product using the filters and search field
5. Open the product page

The Configuration button to the right of the product image opens the Product Configurator.



Product Configurator - the tool for individual product configuration

- Up-to-the-minute configuration data
- Depending on the device: direct input of information specific to the measuring point, such as the measuring range or operating language
- Automatic verification of exclusion criteria
- Automatic creation of the order code and its breakdown in PDF or Excel output format
- Ability to order directly in the Endress+Hauser Online Shop

5-point linearity protocol

Conditions for 5-point linearity protocol

- The 5-point linearity protocol applies for the entire measuring system, consisting of the sensor and transmitter. When ordering, specify the transmitter sensor input where the sensor is to be tested.
- The linearization test is conducted under the reference operating conditions of the transmitter.

Position of the linearization points

- The 5 points of the linearity protocol are evenly distributed over the span S.
- In order to define the span, values for **Empty calibration** (E) and **Full calibration** (F) must be specified when ordering.
- The specified values are only used to create the linearity protocol. **Empty calibration** and **Full calibration** are then reset to their factory settings.

Conditions for defining the span

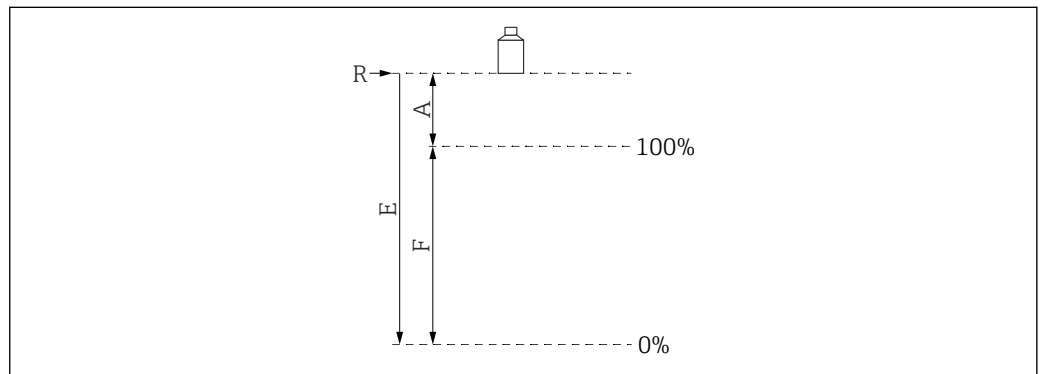

A0019526

12 Variables to define the span

- R Reference point (sensor membrane)
- E "Empty calibration" (distance from sensor membrane to 0%-point)
- F "Full calibration" (distance from 0%-point to 100%-point)
- A Distance from sensor membrane to 100%-point

- $E \leq 10\,000$ mm (394 in)
- $F = 100$ to $9\,700$ mm (3.94 to 382 in)
- $A \geq 300$ mm (11.8 in)

Scope of delivery

- Ordered version of the sensor
- For certified versions: Safety Instructions (XAs)
- For sensors with sensor heater: terminal module for installation in the field housing of the FMU90 transmitter
- For sensors with G1" process connection: counter nut (PA6.6) and seal (EPDM)

Accessories**Sensor extension cable**

-  Maximum permissible total length (sensor cable + extension cable): 300 m (984 ft)
- The sensor cable and extension cable are the same type of cable.

Sensor without sensor heater

- Cable type: LiYCY 2x(0.75)
- Material: PVC
- Ambient temperature: -40 to +105 °C (-40 to +221 °F)
- Order number: 71027742

Sensor with sensor heater

- Cable type: LiYY 2x(0.75)D+2x0.75
- Material: PVC
- Ambient temperature: -40 to +105 °C (-40 to +221 °F)
- Order number: 71027746

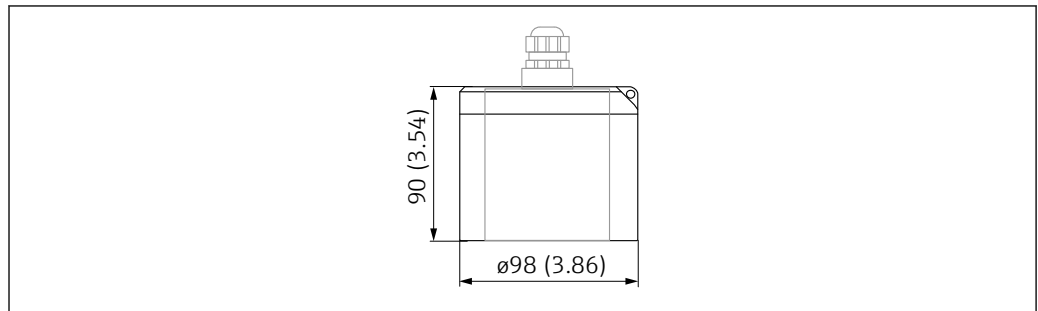
Weather protection cover

A0039949

 13 Weather protection cover. Unit of measurement mm (in)

- **Material:** PVDF
- **Order number:** 52025686

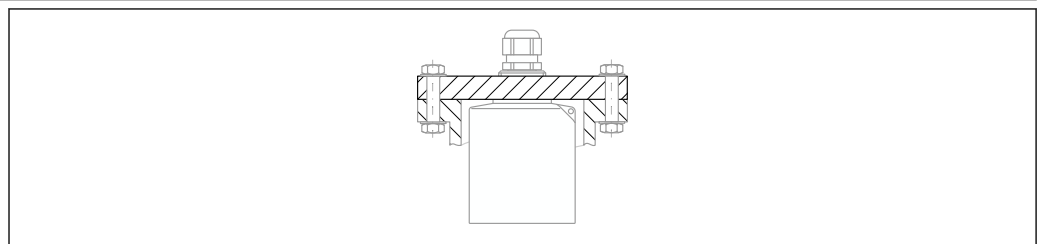
Screw-in flange FAX50

A0044264

-  Mounting on the rear thread G1 or NPT1
- Available flange sizes: see Product Configurator
- Minimum nominal diameter: DN80 / NPS 3"

Cantilever arm for the sensors

Application

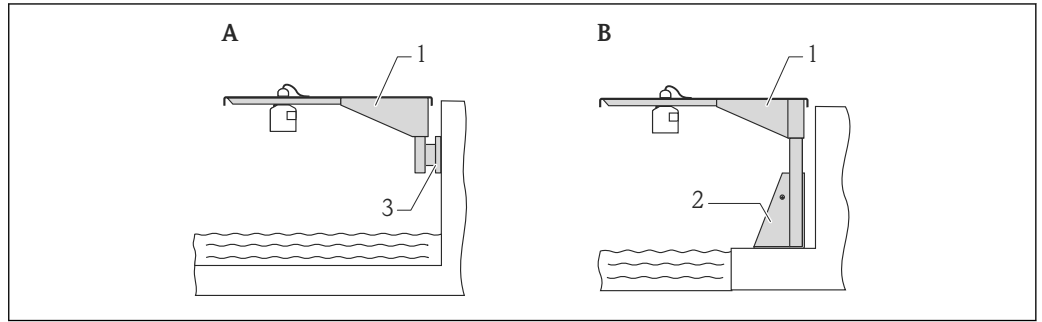

A0019589

14 Mounting of sensor with cantilever arm

- A Installation on arm with wall bracket
- B Installation on arm with mounting frame
- 1 Cantilever
- 2 Mounting frame
- 3 Wall bracket

Use of orifices

- 35 mm (1.4 in) orifice
Sensor with counter nut
- 22 mm (0.9 in) orifice
Temperature sensor (e.g. Omnigrad TR61 with TA50 process connection)

Dimensions

Cantilever arm 500 mm, for G 1" or MNPT 1" connections on rear

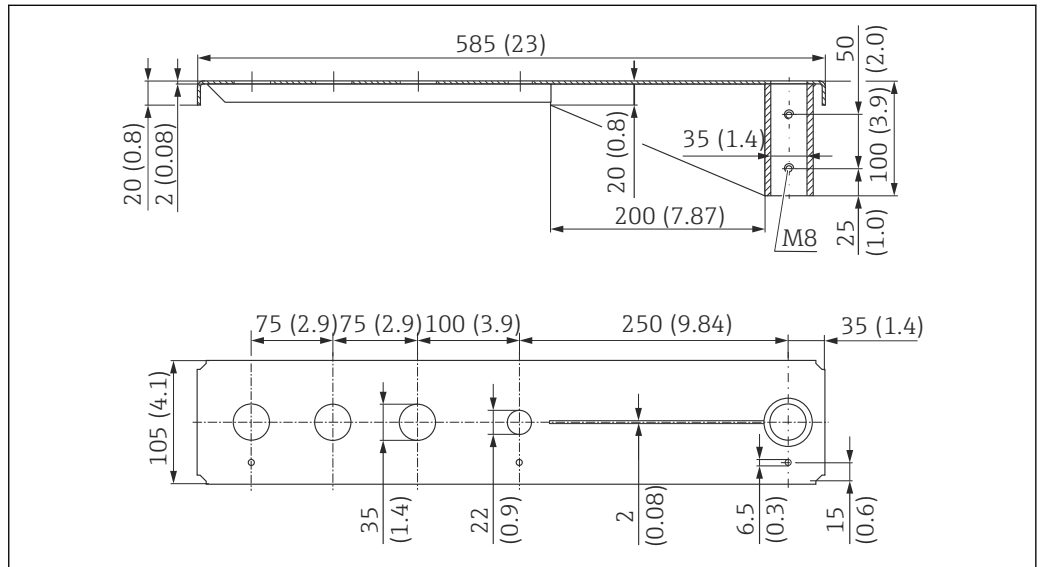

A0037806

15 Dimensions. Unit of measurement mm (in)

Weight:
3.0 kg (6.62 lb)

Material
316L (1.4404)

Order number
71452315

- 35 mm (1.38 in) openings for all G 1" or MNPT 1" connections on rear
- 22 mm (0.87 in) opening can be used for any additional sensor
- Retaining screws are included in delivery

Cantilever arm 1 000 mm, for G 1" or MNPT 1" connections on rear

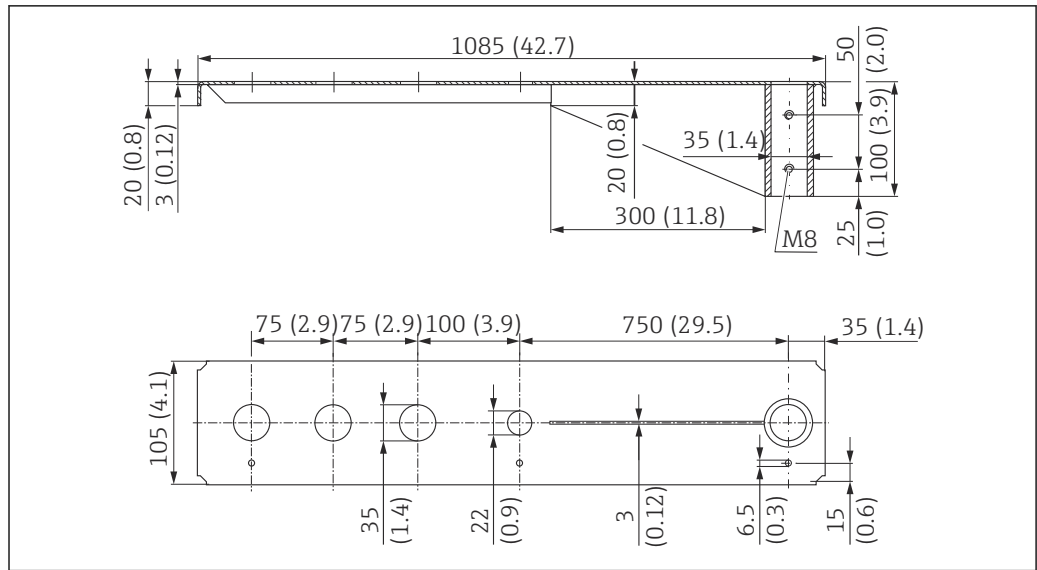

A0037807

16 Dimensions. Unit of measurement mm (in)

Weight:

5.4 kg (11.91 lb)

Material

316L (1.4404)

Order number

71452316

- i** 35 mm (1.38 in) openings for all G 1" or MNPT 1" connections on rear
- 22 mm (0.87 in) opening can be used for any additional sensor
- Retaining screws are included in delivery

Frame, 700 mm (27.6 in)

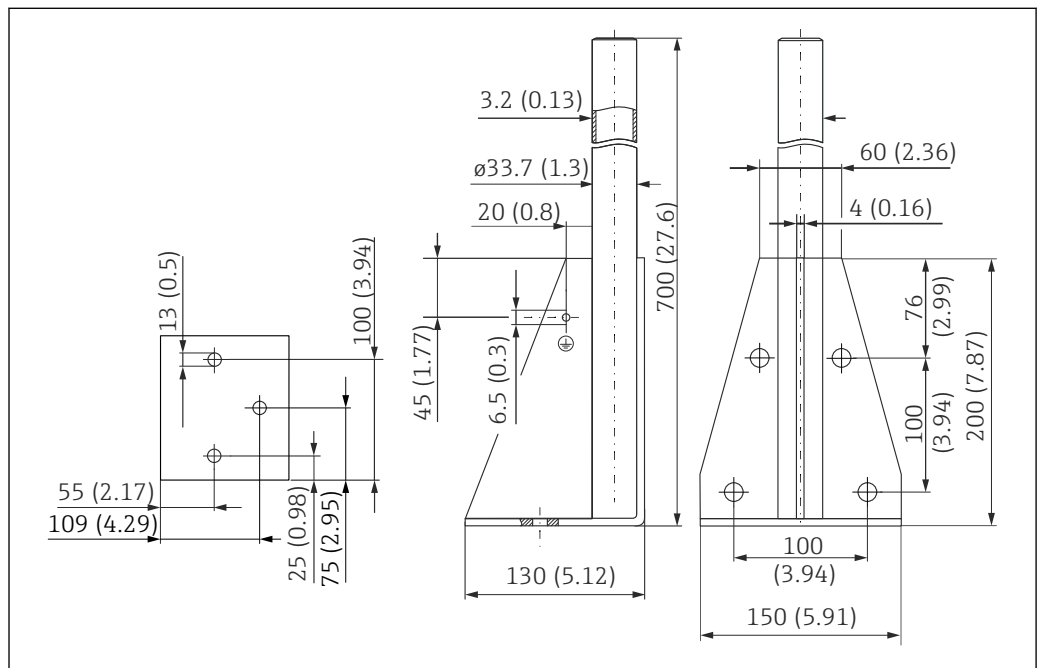

A0037799

17 Dimensions. Unit of measurement mm (in)

Dimensions

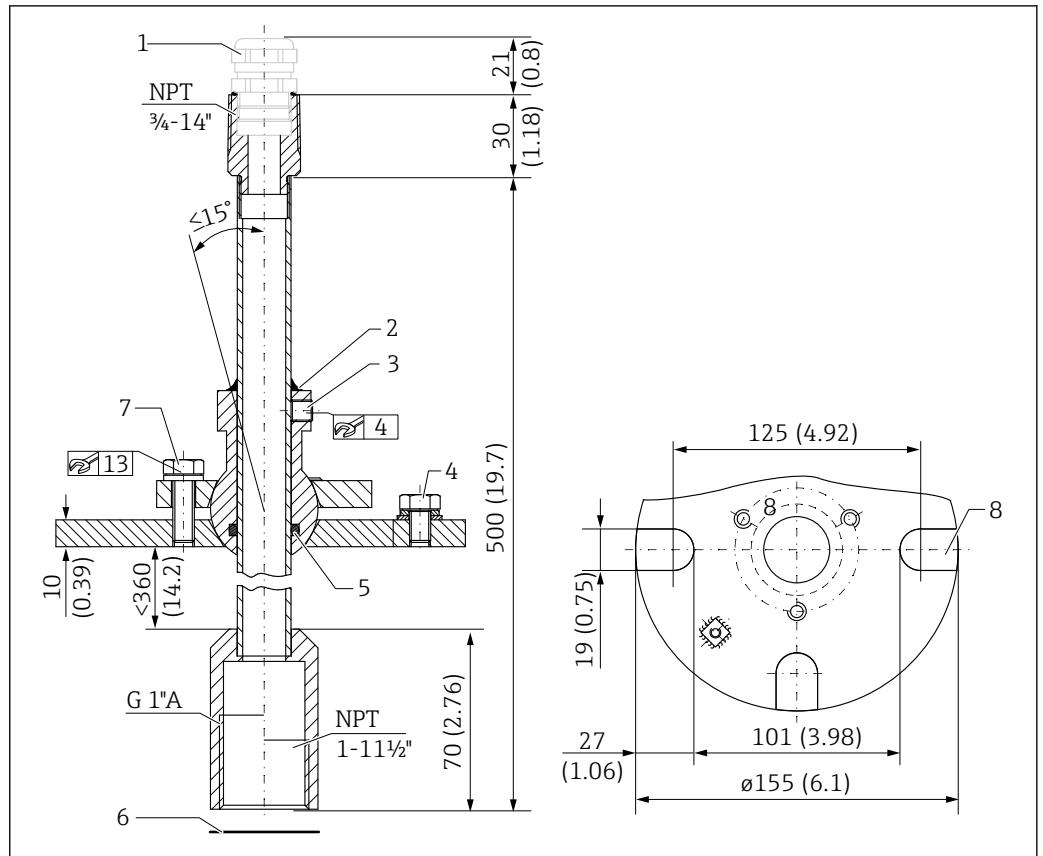

21 FAU40 alignment unit. Unit of measurement mm (in)

- 1 Cable gland M20x1.5 (if selected in the product structure)
- 2 Seal here
- 3 Two Allen screws for height adjustment (8 Nm (6 lbf ft)±2 Nm (±1.5 lbf ft))
- 4 Grounding screw
- 5 O-ring
- 6 Seal supplied with the sensor, must be used for applications in ATEX Zone 20
- 7 Screw for lateral adjustment (18 Nm (13.5 lbf ft)±2 Nm (±1.5 lbf ft))
- 8 Mounting slots (on version with UNI flange)

Additional information

Technical Information TI00179F

RNB130 power supply unit for the sensor heater

Technical data

- **Function:** Primary switched-mode power supply
- **Input:** 100 to 240 V_{AC}
- **Output:** 24 V_{DC}; max 30 V in the event of an error

Connection options

- Single-phase A/C mains system
- Two phase conductors of three-phase supply systems (TN, TT or IT system according to VDE 0100 T 300/IEC 364-3)

Optionally available: IP66 protective housing

Additional information

Technical Information TI00120R

**IP66 protective housing for
RNB130 power supply unit**

- **Order number:** 51002468
- **Additional information:** Technical Information TI00080R

Supplementary documentation

**Documentation for FMU90
transmitter**

- Technical Information TI00397F
- Operating Instructions:
 - BA00288F (HART, level measurement)
 - BA00289F (HART, flow measurement)
 - BA00292F (Profibus DP, level measurement)
 - BA00293F (Profibus DP, flow measurement)
- Description of Device Parameters: GP01151F

**Documentation for FMU95
transmitter**

- Technical Information TI00398F
- Operating Instructions: BA00344F
- Description of Device Parameters: GP01152F

Other documentation



Further information and the documentation currently available can be found on the Endress+Hauser- website: www.endress.com → Downloads.



www.addresses.endress.com
