

# Installation Instructions

## **Kit for Flowfit CPA25**

Spare parts kits for flow assembly CPA25



## Table of contents

1	Overview of the flow assembly .....	3
2	Intended use .....	4
3	Authorized installation personnel .....	4
4	Safety instructions .....	4
5	Scope of delivery .....	5
6	Additional documentation .....	10
7	Replacement of spare parts .....	11
8	Disposal .....	14

# 1 Overview of the flow assembly

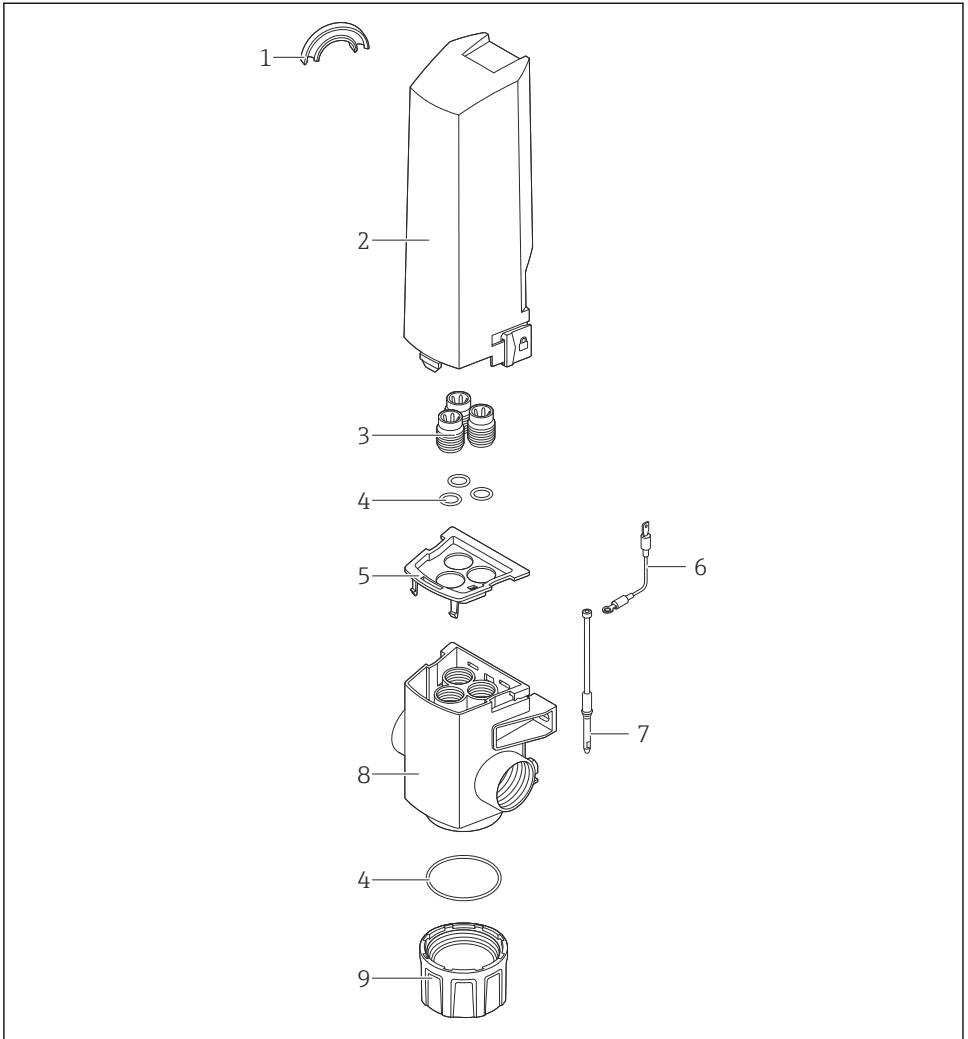

A0052223

## 1 CPA25 design

- |                              |                           |
|------------------------------|---------------------------|
| 1: Hose support for KCl hose | 6: Connecting cable       |
| 2: Protection cover          | 7: Potential matching pin |
| 3: Locking screws            | 8: Flow cell              |
| 4: Seals                     | 9: Service cap            |
| 5: Cover                     |                           |

## 2 Intended use

- The parts of the kits must only be used as maintenance parts for CPA25 flow assemblies. Any other use is not permitted!
- Only use original parts from Endress+Hauser.
- In the W@M Device Viewer, check if the spare part is suitable for the existing device.

## 3 Authorized installation personnel

- Installation, commissioning, operation and maintenance of the measuring system may be carried out only by specially trained technical personnel.
- The technical personnel must be authorized by the plant operator to perform the stated tasks.
- The electrical connection may only be established by an electrical technician.
- The technical personnel must have read and understood these Installation Instructions and must follow the instructions they contain.
- Measuring point faults may be repaired only by authorized and specially trained personnel.
- In the case of Ex-certified devices, the technical staff must also be trained in explosion protection.

 Repairs not described in the Operating Instructions provided must only be carried out directly at the manufacturer's site or by the service organization.

## 4 Safety instructions

### WARNING

**Risk of injury from high pressure, high temperature or chemical hazards if process medium escapes!**

- ▶ Before installing or removing an assembly, depressurize the system, drain the system and clean it.

### CAUTION

**Risk to health due to contact with the process medium!**

- ▶ Pay attention to the warnings in the safety data sheets.
- ▶ Wear protective gloves, protective goggles and protective clothing, particularly when working with reagents, chemicals or process solutions.
- ▶ In case of contact with eyes or skin, rinse the affected area with plenty of water and then seek medical advice. Show the relevant safety data sheet to the physician.

**NOTICE****Material damage due to solvents!**

- ▶ Do not use any halogen-containing organic solvents or acetone. These solvents could destroy plastic components of the assembly.

** Potential impact on the process**

Before decommissioning an active device, the potential impact on the overall process must be taken into account! This applies in particular when using the switching contacts, the analog signal outputs or the communication interface of the associated measuring device to control process variables. Coordinate service tasks with the operator!

## 5 Scope of delivery

### 5.1 Kit CPA25 Sealings

**** The difference between the contents of the following kits is the material of the seals:

- 71572882 Kit CPA25 Sealings EPDM
- 71572884 Kit CPA25 Sealings FKM

The kits contain the following parts →  2,  5:

- |     |   |     |                  |
|-----|---|-----|------------------|
| 1 x | O-ring ID 50.39 W 3.53 OD 57.45 EPDM or FKM<br>depending on option selected | 1 x | Kit instructions |
| 3 x | O-ring ID 10.77 W 2.62 OD 16.01 EPDM or FKM<br>depending on option selected |     |                  |



A0052224

 2 *Kit CPA25 Sealings*

### 5.2 71573088 Kit CPA25 Service cap

The kit contains the following parts →  3,  6:

- |     |                       |     |                  |
|-----|-----------------------|-----|------------------|
| 1 x | Service cap for CPA25 | 1 x | Kit instructions |
|-----|-----------------------|-----|------------------|



A0052225

 3    71573088 Kit CPA25 Service cap

### 5.3      71572887 Kit CPA25 Protective cover

The kit contains the following parts →  4,  6:

- |     |  |     |                                   |
|-----|--|-----|-----------------------------------|
| 1 x | Protection cover for CPA25                 | 1 x | Hybrid open-ended wrench 17/19 AF |
| 1 x | Hose support for KCl hose ID 6 mm, OD 8 mm | 1 x | Kit instructions                  |



A0052226

 4    71572887 Kit CPA25 Protective cover

### 5.4      71573103 Kit CPA25 Cover

The kit contains the following parts →  5,  7:

- |     |                              |     |                  |
|-----|------------------------------|-----|------------------|
| 1 x | Cover of flow cell for CPA25 | 1 x | Kit instructions |
|-----|------------------------------|-----|------------------|

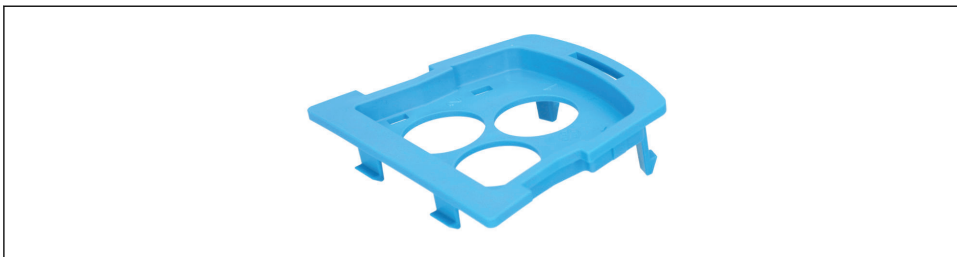

A0052227

5 71573103 Kit CPA25 Cover

## 5.5 Kit CPA25 Potential equalization (PML)

**i** The difference between the contents of the following kits is the material of the potential equalization and the seal:

- 71573106 Kit CPA25 PML 316L/EPDM
- 71573116 Kit CPA25 PML Titanium/EPDM
- 71573119 Kit CPA25 PML 316L/FKM
- 71573121 Kit CPA25 PML Titanium/FKM

The kits contain the following parts → 6, 7:

1 x Potential matching pin SS 316L or 3.7035 depending on option selected	1 x O-ring ID 4.47 W 1.78 OD 8.03 EPDM or FKM depending on option selected
1 x Socket head cap screw M4x80 A4 DIN 912	1 x Potential equalization connecting cable
1 x Spring washer D4 SS 316 DIN 127	1 x Kit instructions

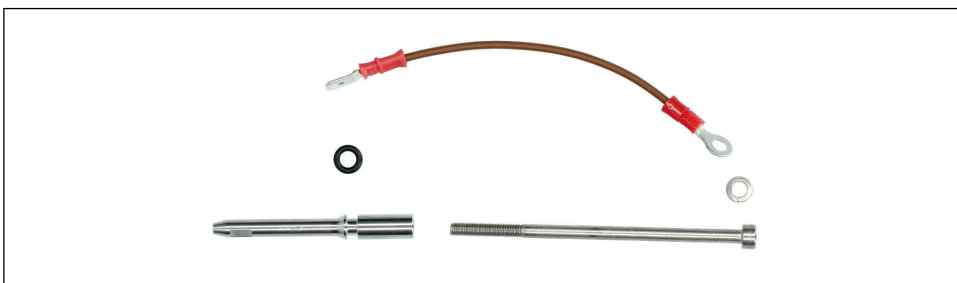

A0052228

6 Kits CPA25 PML

## 5.6 71573122 Kit CPA25 Screw plugs PG13.5

The kit contains the following parts → 7, 8:

3 x Screw plug PG 13.5 PPS	1 x Kit instructions
----------------------------	----------------------



A0052229

 7 71573122 Kit CPA25 Screw plugs PG13.5

## 5.7 71573123 Kit CPA25 Cleaning brushes

The kit contains the following parts →  8,  8:

- 1 x Cleaning brush D 13 mm, length 200 mm, nylon
- 1 x Kit instructions
- 1 x Cleaning brush D 5 mm, length 300 mm, nylon



A0052230

 8 71573123 Kit CPA25 Cleaning brushes

## 5.8 71573126 Kit CPA25 Mounting bracket rail/pipe

The kit contains the following parts →  9,  9:

1 x Pipe/guard rail holder pre-assembled

1 x Kit instructions

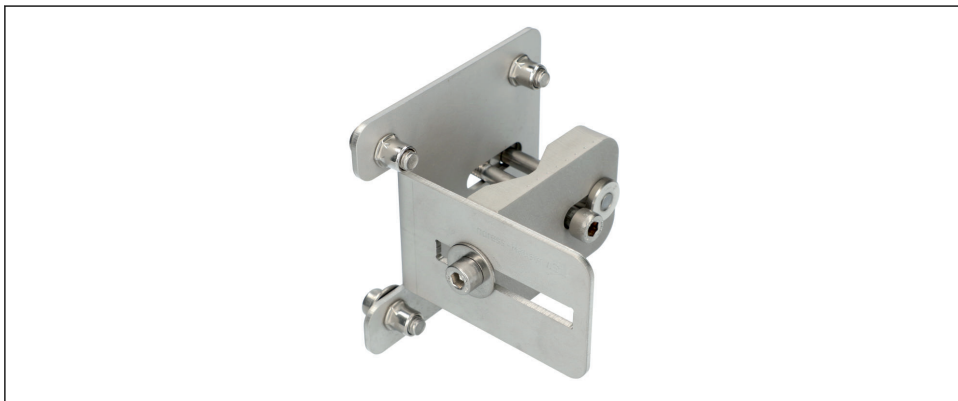

A0052231

 9 71573126 Kit CPA25 Mounting bracket rail/pipe

## 5.9 71573128 Kit Silicone lubricant for sealings

The kit contains the following parts →  10,  9:

1 x Tube of silicone grease 60 g

1 x Kit instructions





A0052232

 10 71573128 Kit Silicone lubricant for sealings

## 5.10 Kit CPA25 Adapter

**i** The difference between the contents of the following kits is the thread size:

- 71604519 Kit CPA25 2x Adapter G1"-G3/4"
- 71604521 Kit CPA25 2x Adapter G1"-G1/2"

The kits contain the following parts →  11,  10:

2 x	Adapter for the G1"-G3/4" or G1"-G1/2" process connection depending on option selected	1 x	Kit instructions
-----	---	-----	------------------

**i** The adapters must be sealed to the assembly by the customer using thread sealing tape.



A0052233

 11 Kit CPA25 Adapter

## 6 Additional documentation

Detailed information on the device can be found in the Operating Instructions for the sensor and in the other documentation available via:

- [www.endress.com/device-viewer](http://www.endress.com/device-viewer)
- Smartphone/tablet: Endress+Hauser Operations app

## 7 Replacement of spare parts

### **CAUTION**

Risk of injury due to severely irritating standard electrolyte!

- Pay attention to the safety instructions (see Section 4).

### 7.1 Replacing the flow cell cover

Remove the cover

1.



A0052275

Release the catches of the cover at the back of the assembly by pressing in gently. Use a screwdriver to do this.

2. Pull the cover upwards and off the assembly.

Fit the cover

1.

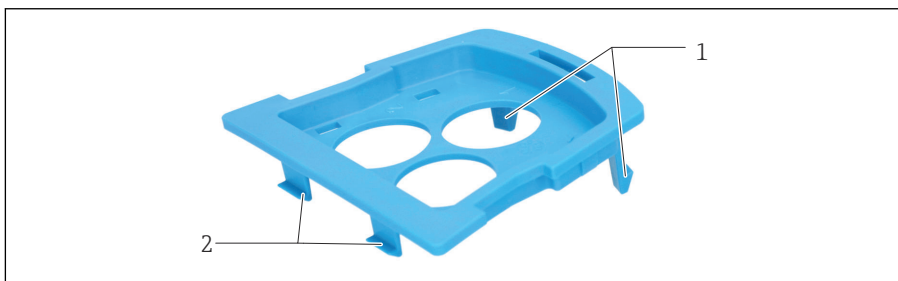

A0052276

Gently insert the cover into the assembly from the front in such a way that the front catches (1) click into place.

2. Gently press the cover downwards until the two rear catches (2) snap into place.

## 7.2 Mounting the potential matching pin

**i** The bore for the potential matching pin is only provided in the flow cell if it was selected when the assembly was ordered (CPA25-\* + NA or + NB). Potential equalization cannot be mounted otherwise!

1. Remove the flow cell cover →  11.
2. Unscrew the lower service cap from the flow cell.
3. Mount the O-ring on the potential matching pin.
- 4.

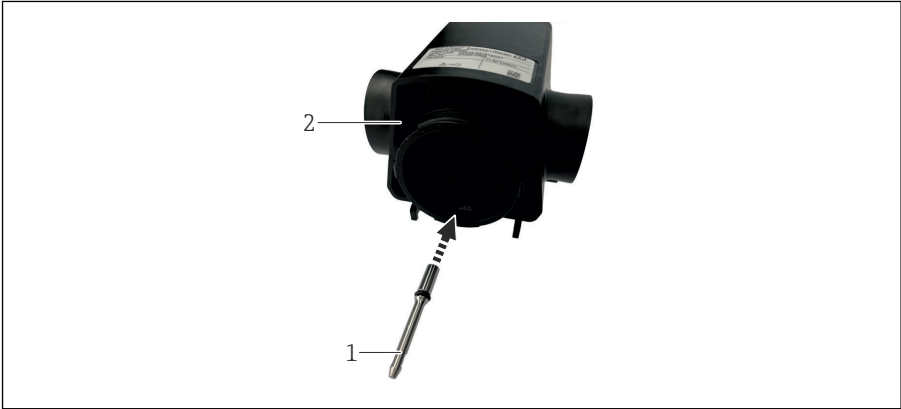

A0052277

Insert the potential matching pin (1) from below into the flow cell bore provided (2).

5.



A0052278

Fit the spring washer (2) onto the socket head cap screw (1).

6.

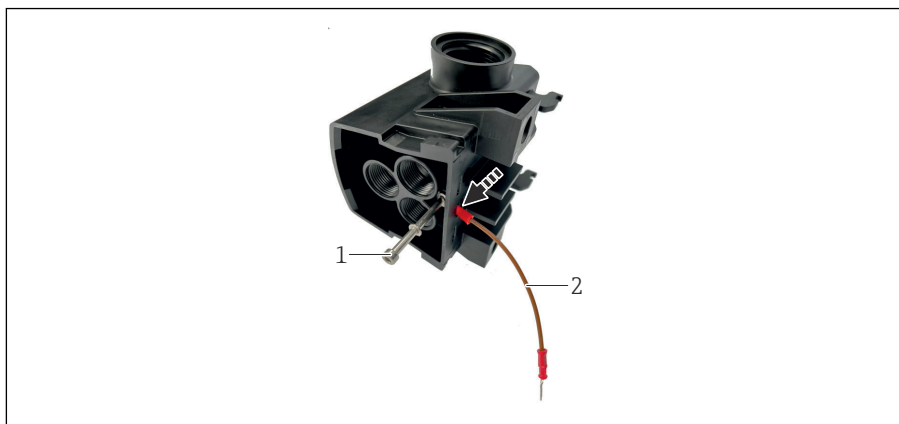

A0052279

Insert the connecting cable (2) through the opening of the flow cell and insert the socket head cap screw (1) into the bore provided. The socket head cap screw must be guided through the bore of the connecting cable.

7. Screw the socket head cap screw to the potential matching pin.
8. Screw on the lower service cap.
9. Fit the flow cell cover.

### 7.3 Mounting the holder on guard rail/pipe

1.

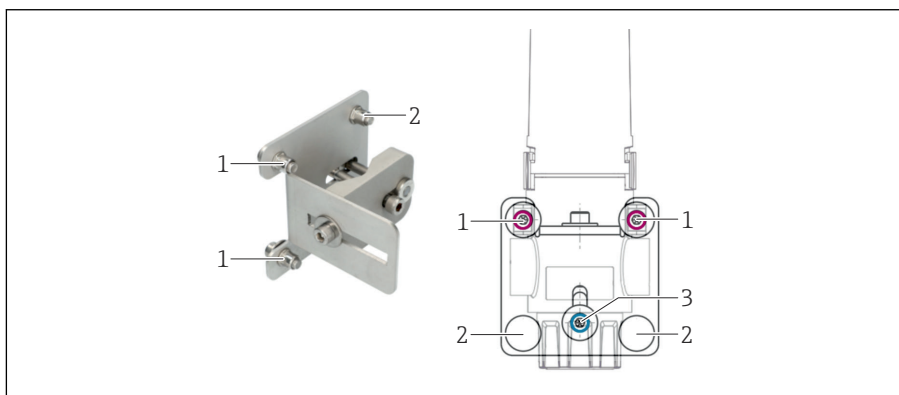

A0052280

Secure the assembly to the holder using the screws (1) (the screws (2) are not required).

2. Clamp the holder to the pipe/guard rail with the screw (3).

## 8 Disposal

### 8.1 Sensors

 If required by the Directive 2012/19/EU on waste electrical and electronic equipment (WEEE), the product is marked with the depicted symbol in order to minimize the disposal of WEEE as unsorted municipal waste. Do not dispose of products bearing this marking as unsorted municipal waste. Instead, return them to the manufacturer for disposal under the applicable conditions.





71759611

[www.addresses.endress.com](http://www.addresses.endress.com)

---