

Technical Information

Memograph M RSG45

Data manager



Advanced data and energy manager with up to 20 analog/HART® inputs and 14 digital inputs

Application

The Advanced Data Manager Memograph M is a flexible and powerful system for organizing process values. Thanks to its intuitive operation, the Memograph M adapts quickly and easily to the respective application. The measured process values are clearly presented on the display and logged safely, monitored against limit values, and analyzed. Via common communication protocols, the measured and calculated values can be easily communicated to higher-level systems and individual plant modules can be interconnected.

Benefits

- High data security: tamper-proof data storage and personalized access authorization with electronic signature (FDA 21 CFR 11)
- 7" TFT display for the clear presentation of measured values
- Stainless steel front with touch operation: trouble-free operation in demanding environments such as hygienic or hazardous areas
- HART® input card: HART® sensors directly connected provide accurate process values for calculation and logging
- HART® gateway: time-saving direct access to HART® sensors in the field with FieldCare using Memograph M without interrupting the measuring loop
- Integrated Web server: remote access to device operation and visualization for lower maintenance costs
- WebDAV: data saved on SD card transmitted directly to a PC via HTTP without any additional software
- Future-focused: simple device upgrade to up to 20 universal/HART® and 14 digital inputs or 12 relay outputs
- System capability: supports common fieldbuses (Modbus, Profibus DP, PROFINET, EtherNet/IP) for fast integration into different systems
- Standard interfaces: can connect a USB keyboard or mouse for faster data entry

Table of contents

About this document	3	Electromagnetic compatibility	23
Safety symbols	3	Mechanical construction	23
Electrical symbols	3	Design and dimensions	23
Symbols for certain types of information	3	Weight	23
Symbols in graphics	3	Materials	23
Function and system design	4	Display and operating elements	24
Measuring principle	4	Operation concept	24
Measuring system	4	Languages	25
Application packages/software options	4	Local operation	25
Dependability	6	Measured value display and operating elements	26
IT security	7	Remote operation	28
Input	7	Certificates and approvals	28
Measured variable	7	CE mark	28
Measuring range	8	Electronic recording/electronic signature	28
Digital inputs	10	Certifications	28
Output	11	Other standards and guidelines	29
Auxiliary voltage output	11	Ordering information	29
Analog and pulse outputs	11	Ordering information	29
Relay output	11	Scope of delivery	29
Galvanic isolation	12	Accessories	30
Electrical connection	12	Device-specific accessories	30
Terminal assignment	12	Communication-specific accessories	32
Supply voltage	12	Service-specific accessories	32
Power consumption	12	Online tools	33
Power supply failure	12	System components	33
Electrical connection, terminal assignment	12	Instructions for enabling a software option	33
Device plugs	17	Documentation	34
Oversvoltage protection	17		
Cable specifications	17		
Connection data interface, communication	18		
Performance characteristics	20		
Response time	20		
Reference operating conditions	20		
Hysteresis	20		
Long-term drift	20		
Mounting	20		
Panel mounting: mounting location and installation dimensions	20		
Mounting location and installation dimensions for the DIN rail version	21		
Field housing assembly and design (optional)	22		
Desktop housing assembly and design (optional)	23		
Environment	23		
Ambient temperature range	23		
Storage temperature	23		
Relative humidity	23		
Operating altitude	23		
Climate class	23		
Electrical safety	23		
Degree of protection	23		

About this document

Safety symbols

⚠ DANGER

This symbol alerts you to a dangerous situation. Failure to avoid this situation will result in serious or fatal injury.

⚠ WARNING

This symbol alerts you to a potentially dangerous situation. Failure to avoid this situation can result in serious or fatal injury.

⚠ CAUTION

This symbol alerts you to a potentially dangerous situation. Failure to avoid this situation can result in minor or medium injury.

NOTICE

This symbol alerts you to a potentially harmful situation. Failure to avoid this situation can result in damage to the product or something in its vicinity.

Electrical symbols



Direct current



Alternating current



Direct current and alternating current



Ground connection

A grounded terminal which, as far as the operator is concerned, is grounded via a grounding system



Protective earth (PE)

Ground terminals that must be connected to ground prior to establishing any other connections
The ground terminals are located on the interior and exterior of the device

- Inner ground terminal; protective earth is connected to the mains supply
- Outer ground terminal; device is connected to the plant grounding system

Symbols for certain types of information

Symbol	Meaning
	Permitted Procedures, processes or actions that are permitted.
	Preferred Procedures, processes or actions that are preferred.
	Forbidden Procedures, processes or actions that are forbidden.
	Tip Indicates additional information.
	Reference to documentation
	Reference to page
	Reference to graphic
	Visual inspection

Symbols in graphics

Symbol	Meaning	Symbol	Meaning
1, 2, 3,...	Item numbers	1. 2. 3. ...	Series of steps
A, B, C, ...	Views	A-A, B-B, C-C, ...	Sections
	Hazardous area		Safe area (non-hazardous area)

Function and system design

Measuring principle

Electronic acquisition, display, recording, analysis, remote transmission and archiving of analog and digital input signals as well as calculated values.

Panel version: Device with display and operating keys for installation in a panel or control cabinet door. Operation in a desktop or field housing is possible as an option.

Panel version with stainless steel front: Device with touch screen (no operating keys) for installation in a panel or a cabinet door. Operation in a desktop or field housing is possible as an option.

DIN rail version: Device without a display or operating keys for mounting on a DIN rail.

Measuring system

Multichannel data recording system with multicolor TFT display (order option, 178 mm (7 in) screen size), internal memory, external memory (SD card and USB stick), galvanically isolated universal inputs (U, I, TC, RTD, pulse, frequency), HART® inputs, digital inputs, transmitter power supply, limit relays, digital and analog outputs, communication interfaces (USB, Ethernet, RS232/485), optionally available with Modbus, Profibus DP or PROFINET I/O or EtherNet/IP.

An Essential Version of the Field Data Manager (FDM) software can be downloaded at www.endress.com/ms20 for SQL-supported data analysis at the PC.

 The number of inputs available in the basic device can be individually increased using a maximum of 5 plug-in cards. The device supplies power directly to connected two-wire transmitters. The device is configured and operated via the navigator (jog/shuttle dial) or by touchscreen (optional) using the integrated web server and a PC, an external USB keyboard or mouse or with the FieldCare/DeviceCare configuration software. Online help supports the user during local operation.

 **Ex version:**

- The hazardous area version (Ex version) is only available in conjunction with the stainless steel front and touch control.
- In this version, the SD card is integrated in the device and cannot be removed. The card can be read out using the optional Field Data Manager (FDM) software via USB or Ethernet or via WebDAV.

Application packages/ software options

In the standard version, the Advanced Data Manager has a variety of functions, including an end-to-end safety concept to meet the requirements of FDA 21 CFR Part 11. The following application packages are available to help users meet the requirements of their applications and save time:

- Mathematics
- Telealarm
- Batch management
- Wastewater + RSB (rain spillway basin)
- Energy calculation

The application packages contain the standard functions and the specific package functions. The individual packages can be largely combined as the user requires. The application packages can also be activated retroactively by entering the activation code.

Standard functions

- Signal analysis: external, 1 min to 12 h, day, week, month, year
- Web server
- User administration compliant with FDA 21 CFR Part 11
- Event logbook/audit trail
- Process screen
- Operating time counter
- Text entry/comments
- Change language
- Time synchronization
- Linearization
- Access protection through release code
- E-mail notification in event of alarms and limit violation
- Encrypted e-mail transmission via SSL (TLS)
- Operation via external USB keyboard and mouse
- External USB or network printer

Mathematics

With the mathematics package, measured values of the inputs or the results of other math channels can be linked mathematically. A formula with up to 200 characters can be created using a formula editor. Once entered, the user can then check the plausibility of the formula.

Functions:

- 12 math channels
- Mathematics functions via formula editor
- Basic arithmetic operations, relational operators, logic operations and functions

Telealarm software

The Telealarm software facilitates user mobility, allowing users to respond to events while they are on the road. E-mails or SMS messages triggered by process alarms or other important process events can be sent to several recipients simultaneously or automatically forwarded to a recipient/destination. Messages can be confirmed, relays controlled remotely and current values queried by cellular phone. The Advanced Data Manager with GSM (GPRS) or Ethernet is ideal both for environmental applications to monitor unstaffed outstations, and for tank monitoring applications.



The Telealarm software contains the mathematics package.

Functions:

- Advanced SMS/e-mail notification in the event of an alarm
- Instantaneous values queried by cellular phone
- Remote relay switching
- Alarm confirmation by SMS

Batch software

Batch management allows users to reliably record and visualize discontinuous processes. User-definable or externally controlled analysis intervals are possible for up to four batches simultaneously. Batches are assigned batch-specific values and the measured data, the start, end and duration of every batch, along with the current batch status, are displayed on the device and in the Field Data Manager software. At the end of the batch, batch information is automatically printed out directly at the device (USB or network printer) or is printed out via a PC with the Field Data Manager software.



The batch software contains the mathematics package.

Functions:

- Batch report for 4 batches simultaneously
- USB barcode reader
- Automatic batch printout
- Preset counter

Wastewater + RSB (rain spillway basin)

The water/wastewater software supports operations monitoring of the water/wastewater sewage network to obtain information about the quality and efficiency of the plant. The daily, weekly, monthly and yearly maximum and minimum value is determined per quantity channel. Infiltration water recording and the monitoring of rain spillway basins for reservoir and overflow events are also functions of this software option.



The water/wastewater software contains the mathematics package and the Telealarm software.

Functions:

- Rain spillway basin (reservoir/overflow)
- Highest and lowest values for quantities
- Highest and lowest values from ¼-hourly averages
- Determination of infiltration water

Energy package (water + steam)

The energy package allows users to calculate the mass and energy flow in water and steam applications on the basis of the flow, pressure and temperature (or temperature differential). Furthermore, energy calculations are also possible using glycol-based refrigerant media.

By balancing the results against one another or by linking the results to other input variables (e.g., gas flow, electrical energy), users can calculate overall balances, efficiency levels etc. These values

are important indicators for the quality of the process and form the basis for process optimization and maintenance.

The internationally recognized standard IAPWS-IF 97 is used to calculate the thermodynamic state variables of water and steam.

In the energy software, it is also possible to compensate differential pressure flow measurement ("DP-Flow"). The calculation of flow based on the differential pressure method is a special form of flow measurement. Volumes or mass flow rates that are determined using the DP method require specific correction. By solving the calculation equations listed in the standard in an iterative manner, highly accurate results for DP flow measurements can be achieved. The measurement (orifice plate, nozzle, Venturi pipe) is performed in accordance with ISO5167. Flow measurement based on the dynamic pressure method uses the interrelation between differential pressure and flow.



The energy package contains the mathematics package.

Additional functions:

- 12 math channels
(Channels 1-8: energy-specific formulas and formula editor, channels 9-12: formula editor)
- Heat quantity + mass calculation for water and steam applications
- Efficiency calculation

iTherm TrustSens Calibration Monitoring



Available in conjunction with iTHERM TrustSens TM371, TM372.

Application package :

- Up to 20 iTHERM TrustSens TM371, TM372 devices can be evaluated via the HART interface
- Self-calibration data displayed on screen or via the web server
- Generation of a calibration history
- Creation of a calibration certificate as an RTF file directly at the RSG45
- Evaluation, analysis and further processing of the calibration data using "Field Data Manager" (FDM) analysis software

Dependability

Reliability

Depending on the device version, the mean time between failures (MTBF) is between 52 years and 16 years (calculated based on SN29500 standard at 40 °C (104 °F))

Maintainability

Battery-backed time and data memory. It is advisable to have the backup battery replaced by a service technician after 10 years.

Real-time clock (RTC)

- Automatic or manual summer time changeover
- Battery buffer. It is advisable to have the backup battery replaced by a service technician after 10 years.
- Drift: <10 min./year.
- Time synchronization possible via SNTP or via digital input.

Standard diagnostic functions as per NAMUR NE 107

The diagnostic code consists of the status signal as per NAMUR NE 107 and the event number.

- Cable open circuit, short-circuit
- Incorrect wiring
- Internal device errors
- Overrange/underrange detection
- Ambient temperature out-of-range detection

Device error/alarm relay

One relay can be used as an alarm relay. The selected relay switches if the device detects a system error (e.g., hardware defect) or a malfunction (e.g., cable open circuit).

This "alarm relay" switches if the device status is "F" (Failure). If the device status is "M" (Maintenance required), the alarm relay does not switch.

Safety

Recorded data are saved in a tamper-proof format and can be exported and archived with manipulation protection using the Field Data Manager software.

IT security

The manufacturer only provides a warranty if the device is installed and used as described in the Operating Instructions. The device is equipped with security mechanisms to protect it against any inadvertent changes to the device settings.

IT security measures in line with operators' security standards and designed to provide additional protection for the device and device data transfer must be implemented by the operators themselves.

Input

Measured variable

Analog universal inputs

Standard version without universal inputs. Optional multifunction cards (slot 1-5) with 4 universal inputs (4/8/12/16/20) each.

You are free to choose between the following measured variables for each universal input: U, I, RTD, TC, pulse input or frequency input.

Integration of input variable for totalization such as flow (m³/h) in quantity (m³).

HART® inputs

Standard version without HART® inputs. Optional HART® input cards (slot 1-5) with 4 inputs (4/8/12/16/20) each.

Both the digital HART® values and the 4 to 20 mA signal can be evaluated at every input.

The 4 HART® values (PV, SV, TV, QV) of a sensor can be evaluated and the analog HART® value (PV) can be measured via the digital HART® signal. Up to 40 digital HART® values can be recorded in total. It is possible to access the HART® sensor in the field from a PC tool (e.g., FieldCare). In this way, the sensor can be configured from the control room and the status information of the sensor can be analyzed/displayed. The Memograph M acts as a HART® Gateway.



Access to the connected sensors is only possible if the device is connected by Ethernet. Port 5094 must be open in the firewall.

Digital inputs

Standard version: 6 digital inputs

Optional digital card (slot 5): 8 additional digital inputs, 6 additional relays and 2 analog outputs

Mathematics channels

12 math channels (optional). Mathematics functions can be freely edited via a formula editor.

Integration of calculated values for totalization.

Limit values

60 limit values (individual channel assignment)

Calculated process variables

The values of the universal and HART® inputs can be used to perform calculations in the math channels.

The results of the math channels can also be used for calculations in other math channels.

Measuring range According to IEC 60873-1: An additional display error of ± 1 digit is permitted for every measured value.

User-definable measuring ranges per universal input of the multifunction card:

Measured variable	Measuring range	Maximum measurement error of measuring range (oMR), temperature drift	Input resistance
Current (I)	0 to 20 mA; 0 to 20 mA quadratic 0 to 5 mA 4 to 20 mA; 4 to 20 mA quadratic ± 20 mA Over range: up to 22 mA or -22 mA	$\pm 0.1\%$ oMR Temperature drift: $\pm 0.01\%/K$ oMR	Load: 50 Ω $\pm 1 \Omega$
Voltage (U) >1 V	0 to 10 V; 0 to 10 V quadratic 0 to 5 V 1 to 5 V; 1 to 5 V quadratic ± 10 V ± 30 V	$\pm 0.1\%$ oMR Temperature drift: $\pm 0.01\%/K$ oMR	≥ 1 M Ω
Voltage (U) ≤ 1 V	0 to 1 V; 0 to 1 V quadratic ± 1 V ± 150 mV	$\pm 0.1\%$ oMR Temperature drift: $\pm 0.01\%/K$ oMR	≥ 2.5 M Ω
Resistance thermometers (RTD)	Pt100: -200 to 850 °C (-328 to 1562 °F) (IEC 60751:2008, $\alpha=0.00385$) Pt100: -200 to 510 °C (-328 to 950 °F) (JIS C 1604:1984, $\alpha=0.003916$) Pt100: -200 to 850 °C (-328 to 1562 °F) (GOST 6651-94, $\alpha=0.00391$) Pt500: -200 to 850 °C (-328 to 1562 °F) (IEC 60751:2008, $\alpha=0.00385$) Pt500: -200 to 510 °C (-328 to 950 °F) (JIS C 1604:1984, $\alpha=0.003916$) Pt1000: -200 to 600 °C (-328 to 1112 °F) (IEC 60751:2008, $\alpha=0.00385$) Pt1000: -200 to 510 °C (-328 to 950 °F) (JIS C 1604:1984, $\alpha=0.003916$)	4-wire: $\pm 0.1\%$ oMR 3-wire: $\pm(0.1\%$ oMR + 0.8 K) 2-wire: $\pm(0.1\%$ oMR + 1.5 K) Temperature drift: $\pm 0.01\%/K$ oMR	
	Cu50: -50 to 200 °C (-58 to 392 °F) (GOST 6651-94, $\alpha=4260$) Cu50: -200 to 200 °C (-328 to 392 °F) (GOST 6651-94, $\alpha=4280$) Pt50: -200 to 1100 °C (-328 to 2012 °F) (GOST 6651-94, $\alpha=0.00391$) Cu100: -200 to 200 °C (-328 to 392 °F) (GOST 6651-94, $\alpha=4280$)	4-wire: $\pm 0.2\%$ oMR 3-wire: $\pm(0.2\%$ oMR + 0.8 K) 2-wire: $\pm(0.2\%$ oMR + 1.5 K) Temperature drift: $\pm 0.02\%/K$ oMR	
	Pt46: -200 to 1100 °C (-328 to 2012 °F) (GOST 6651-94, $\alpha=0.00391$) Cu53: -200 to 200 °C (-328 to 392 °F) (GOST 6651-94, $\alpha=4280$)	4-wire: $\pm 0.3\%$ oMR 3-wire: $\pm(0.3\%$ oMR + 0.8 K) 2-wire: $\pm(0.3\%$ oMR + 1.5 K) Temperature drift: $\pm 0.02\%/K$ oMR	
Thermocouples (TC)	Type J (Fe-CuNi): -210 to 1200 °C (-346 to 2192 °F) (IEC 60584:2013) Type K (NiCr-Ni): -270 to 1300 °C (-454 to 2372 °F) (IEC 60584:2013) Type L (NiCr-CuNi): -200 to 800 °C (-328 to 1472 °F) (GOST R 8.585:2001) Type L (Fe-CuNi): -200 to 900 °C (-328 to 1652 °F) (DIN 43710-1985) Type N (NiCrSi-NiSi): -270 to 1300 °C (-454 to 2372 °F) (IEC 60584:2013) Type T (Cu-CuNi): -270 to 400 °C (-454 to 752 °F) (IEC 60584:2013)	$\pm 0.1\%$ oMR from -100 °C (-148 °F) $\pm 0.1\%$ oMR from -130 °C (-202 °F) $\pm 0.1\%$ oMR from -100 °C (-148 °F) $\pm 0.1\%$ oMR from -100 °C (-148 °F) $\pm 0.1\%$ oMR from -100 °C (-148 °F) $\pm 0.1\%$ oMR from -200 °C (-328 °F) Temperature drift: $\pm 0.01\%/K$ oMR	≥ 1 M Ω
	Type A (W5Re-W20Re): 0 to 2500 °C (32 to 4532 °F) (ASTME 988-96) Type B (Pt30Rh-Pt6Rh): 42 to 1820 °C (107.6 to 3308 °F) (IEC 60584:2013) Type C (W5Re-W26Re): 0 to 2315 °C (32 to 4199 °F) (ASTME 988-96) Type D (W3Re-W25Re): 0 to 2315 °C (32 to 4199 °F) (ASTME 988-96) Type R (Pt13Rh-Pt): -50 to 1768 °C (-58 to 3214 °F) (IEC 60584:2013) Type S (Pt10Rh-Pt): -50 to 1768 °C (-58 to 3214 °F) (IEC 60584:2013)	$\pm 0.15\%$ oMR from 500 °C (932 °F) $\pm 0.15\%$ oMR from 600 °C (1112 °F) $\pm 0.15\%$ oMR from 500 °C (932 °F) $\pm 0.15\%$ oMR from 500 °C (932 °F) $\pm 0.15\%$ oMR from 100 °C (212 °F) $\pm 0.15\%$ oMR from 100 °C (212 °F) Temperature drift: $\pm 0.01\%/K$ oMR	≥ 1 M Ω
Pulse input (I) ¹⁾	Min. pulse length 40 μ s, max. 12.5 kHz; 0 to 7 mA = LOW; 13 to 20 mA = HIGH		Load: 50 Ω $\pm 1 \Omega$
Frequency input (I) ¹⁾	0 to 10 kHz, over range: up to 12.5 kHz; 0 to 7 mA = LOW; 13 to 20 mA = HIGH	$\pm 0.02\%$ @ f < 100 Hz of reading $\pm 0.01\%$ @ f ≥ 100 Hz of reading Temperature drift: 0.01% of measured value over the entire temperature range	

1) If a universal input is used as a frequency or pulse input, a series resistor must be used in series connection with the voltage source. Example: 1.2 k Ω series resistor at 24 V

Current measuring range of the HART® card:

Measured variable	Measuring range	Maximum measurement error of measuring range (oMR), temperature drift	Input impedance
Current (I)	4 to 20 mA Over range: up to 22 mA	±0.1% oMR Temperature drift: ±0.01%/K oMR	Load: 10 Ω ±1 Ω

Maximum load and additional input parameters of the multifunction cards

Limit values for input voltage and current as well as cable open circuit detection/line influence/temperature compensation:

Measured variable	Limit values (steady-state, without destroying input)	Cable open circuit detection/line influence/temperature compensation
Current (I)	Maximum permitted input voltage: 2.5 V Maximum permitted input current: 50 mA	4 to 20 mA range with disengageable cable open circuit monitoring to NAMUR NE43. The following error ranges apply when NAMUR NE43 monitoring is switched on: ≤3.8 mA: under range ≥20.5 mA: over range ≤ 3.6 mA or ≥ 21.0 mA: cable open circuit (display shows: - - - -)
Pulse, frequency (I)	Maximum permitted input voltage: 2.5 V Maximum permitted input current: 50 mA	No cable open circuit monitoring
Voltage (U) >1 V	Maximum permitted input voltage: 35 V	1 to 5 V range with disengageable cable open circuit monitoring: <0.8 V or >5.2 V: cable open circuit (display shows: - - - -)
Voltage (U) ≤1 V	Maximum permitted input voltage: 24 V	
Resistance thermometers (RTD)	Measuring current: ≤1 mA	Maximum barrier resistance (or resistivity): 4-wire: max. 200 Ω; 3-wire: max. 40 Ω Maximum influence of barrier resistance (or resistivity) for Pt100, Pt500 and Pt1000: 4-wire: 2 ppm/Ω, 3-wire: 20 ppm/Ω Maximum influence of barrier resistance (or resistivity) for Pt46, Pt50, Cu50, Cu53, Cu100 and Cu500: 4-wire: 6 ppm/Ω, 3-wire: 60 ppm/Ω Cable open circuit monitoring if any connection is interrupted.
Thermocouples (TC)	Maximum permitted input voltage: 24 V	Influence of resistivity: <0.001%/Ω Error, internal temperature compensation: ≤ 2 K

Maximum load and additional input parameters of the HART® cards

Limit values for input voltage and current as well as cable open circuit detection:

Measured variable	Limit values (steady-state, without destroying input)	Cable open circuit detection
Current (I)	Maximum permitted input voltage: 0.5 V Maximum permitted input current: 50 mA	4 to 20 mA range with disengageable cable open circuit monitoring to NAMUR NE43. The following error ranges apply when NAMUR NE43 monitoring is switched on: ≤3.8 mA: under range ≥20.5 mA: over range ≤ 3.6 mA or ≥ 21.0 mA: cable open circuit (display shows: - - - -)

Scan rate

Current/voltage/pulse/frequency input: 100 ms per channel

Thermocouples and resistance thermometer: 1 s per channel

Data storage/save cycle

Choose from the following for the save cycle: off / 100 ms / 1s / 2s / 3s / 4s / 5s / 10s / 15s / 20s / 30s / 1min / 2min / 3min / 4min / 5min / 10min / 15min / 30min / 1h

 High-speed storage (100 ms) can be selected for up to 8 channels in Group 1 only.

High-speed storage is not available in the energy package (option).

Typical logging duration**Prerequisites for following tables:**

- No limit value violation / integration
- Digital input not used
- Signal analysis 1: off, 2: day, 3: month, 4: year
- No active mathematics channels



Frequent entries in the event logbook reduce the memory availability!

256 MB internal memory:

Analog inputs	Channels in groups	Save cycle (weeks, days, hours)				
		5 min	1 min	30 s	10 s	1 s
1	1/0/0/0/0/0/0/0/0/0	1796, 6, 13	362, 5, 17	181, 4, 9	60, 4, 3	6, 0, 10
4	4/0/0/0/0/0/0/0/0/0	1319, 2, 23	267, 5, 17	134, 1, 2	44, 5, 10	4, 3, 8
8	4/4/0/0/0/0/0/0/0/0	661, 4, 3	133, 6, 21	67, 0, 16	22, 2, 17	2, 1, 16
12	4/4/4/0/0/0/0/0/0/0	441, 3, 8	89, 2, 9	44, 5, 3	14, 6, 11	1, 3, 10
20	4/4/4/4/4/0/0/0/0/0	265, 0, 15	53, 4, 7	26, 5, 21	8, 6, 16	0, 6, 6
40	4/4/4/4/4/4/4/4/4/4	132, 4, 8	26, 5, 16	13, 2, 23	4, 3, 8	0, 3, 3

External memory, 1 GB SD card:

Analog inputs	Channels in groups	Save cycle (weeks, days, hours)				
		5 min	1 min	30 s	10 s	1 s
1	1/0/0/0/0/0/0/0/0/0	12825, 5, 20	2580, 4, 18	1291, 2, 5	430, 4, 14	43, 0, 12
4	4/0/0/0/0/0/0/0/0/0	8672, 5, 12	1749, 6, 13	875, 6, 13	292, 1, 8	29, 1, 14
8	4/4/0/0/0/0/0/0/0/0	4343, 1, 1	875, 1, 17	438, 0, 6	146, 0, 17	14, 4, 7
12	4/4/4/0/0/0/0/0/0/0	2896, 6, 13	583, 3, 21	292, 0, 6	97, 2, 20	9, 5, 4
20	4/4/4/4/4/0/0/0/0/0	1738, 6, 4	350, 1, 3	175, 1, 14	58, 3, 2	5, 5, 22
40	4/4/4/4/4/4/4/4/4/4	869, 5, 0	175, 0, 15	87, 4, 7	29, 1, 13	2, 6, 11

Converter resolution

24 bit

Totalization

The interim, daily, weekly, monthly and yearly value and the total value can be determined (15-digit, 64 bit).

Analysis

Recording of quantity/operating time (standard function), also a min/max/median analysis within the set time frame.

Digital inputs	Input level	Logical "0" (corresponds to -3 to +5 V), activation with logical "1" (corresponds to +12 to +30 V)
	Input frequency	Max. 25 Hz
	Pulse length	Min. 20 ms (pulse counter)
	Pulse length	Min. 100 ms (control input, messages, operating time)
	Input current	Max. 2 mA
	Input voltage	Max. 30 V

Selectable functions

- Functions of the digital input: control input, ON/OFF event, pulse counter (15-digit, 64 bit), operating time, event + operating time, quantity from time, Profibus DP, EtherNet/IP, PROFINET.
- Functions of the control input: start recording, screensaver on, lock setup, time synchronization, change group, limit value monitoring on/off, individual LV on/off, block keyboard/navigator, start/stop analysis.
 Additionally for the batch software option: reset batch number, batch limit values on/off.

Output

Auxiliary voltage output

The auxiliary voltage output can be used for loop power supply or to control the digital inputs. The auxiliary voltage is short-circuit proof and galvanically isolated.

Output voltage	24 V _{DC} ±15%
Output current	Max. 250 mA

Analog and pulse outputs

Number

Optional digital card (slot 5): 2 analog outputs which can be operated as current or pulse outputs.

Analog output (current output)

- Output current: 0/4 to 20 mA with 10% over range
- Max. output voltage: approx. 16 V
- Accuracy: ≤0.1% of upper range value
- Temperature drift: ≤0.015%/K of upper range value
- Resolution: 13 Bit
- Load: 0 to 500 Ω
- Error signal as per NAMUR NE43: 3.6 mA or 21 mA can be configured

Digital output (pulse output)

- Output voltage:
 ≤5 V corresponds to LOW
 ≥12 V corresponds to HIGH
 Short-circuit proof (maximum 25 mA)
- Speed: max. 1000 pulses/s
- Pulse width: 0.5 to 1000 ms

 The pulse pause is at least as long as the pulse width.

Load: ≥1 kΩ

Relay output

A mix of low voltage (230 V) and safety extra low voltage (SELV circuits) is not permitted at the connections of the relay contacts.

Alarm relay

1 alarm relay with changeover contact.

Standard relay

5 relays with NO contact, e.g., for limit value messages (can be configured as NC contact).

Optional relays

Optional digital card (slot 5): 6 additional relays with NO contact, e.g., for limit value alarms (can be configured as an NC contact).

Switching capacity

- Max. relay switching capacity: 3 A @ 30 V DC
- Max. relay switching capacity: 3 A @ 250 V AC
- Min. switching load: 300 mW

Switching cycles

>10⁵

Galvanic isolation

The following connections are galvanically isolated from one another:

- Current supply
- Relay outputs
- Digital inputs (isolated from other connections but not from each other)
- Analog inputs
- Analog outputs
- Ethernet
- RS232/RS485
- USB
- Auxiliary voltage output

Electrical connection

Terminal assignment

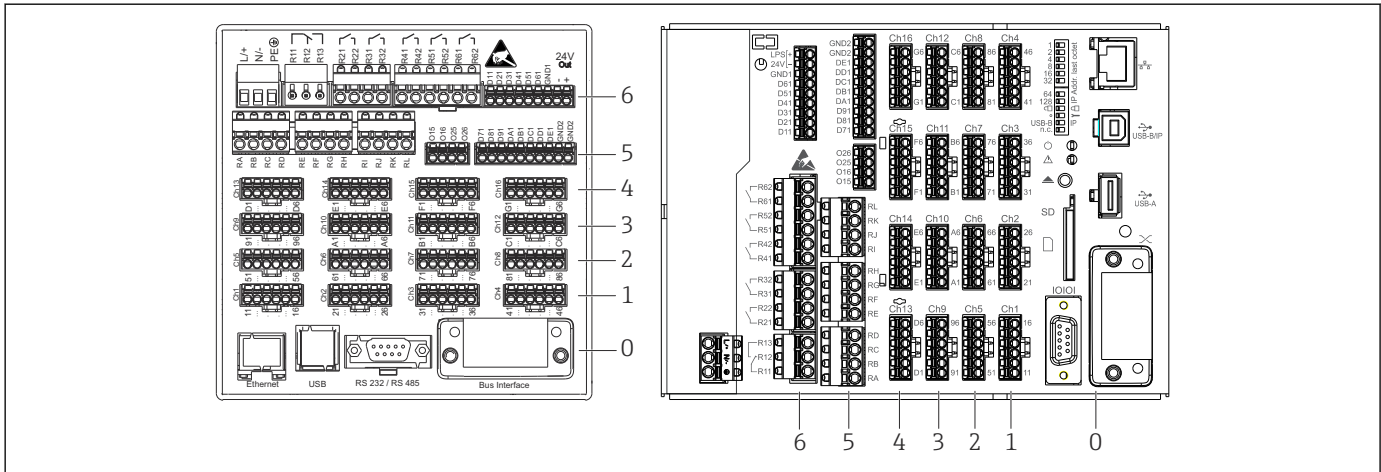

A0024605

1 Connections: back of device, panel version (left), DIN rail version (right)

- 6 Slot 6: Power supply with relays
- 5 Slot 5: Multifunction card or HART® card (channels 17-20) or digital card
- 4 Slot 4: Multifunction card or HART® card (channels 13-16)
- 3 Slot 3: Multifunction card or HART® card (channels 9-12)
- 2 Slot 2: Multifunction card or HART® card (channels 5-8)
- 1 Slot 1: Multifunction card or HART® card (channels 1-4)
- 0 Slot 0: CPU card with interfaces

Supply voltage

- Extra-low voltage power supply unit ±24 V AC/DC (-10% / +15%) 50/60Hz
- Low voltage power supply unit 100 to 230 V AC (±10%) 50/60Hz

i Overcurrent protection (rated current ≤ 10 A) must be installed for the power cable.

Power consumption

- 100 to 230 V: max. 47 VA
- 24 V: max. 30 VA

The power actually consumed depends on the individual operating state and the device version (LPS, USB, brightness of screen, number of channels, etc.). The active power here is approx. 3 W to 25 W.

Power supply failure

Battery-backed time and data memory. The device starts automatically following a power failure.

Electrical connection, terminal assignment

i All connection examples are illustrated using the panel version. The connections on the DIN rail version are identical.

Circuit diagram

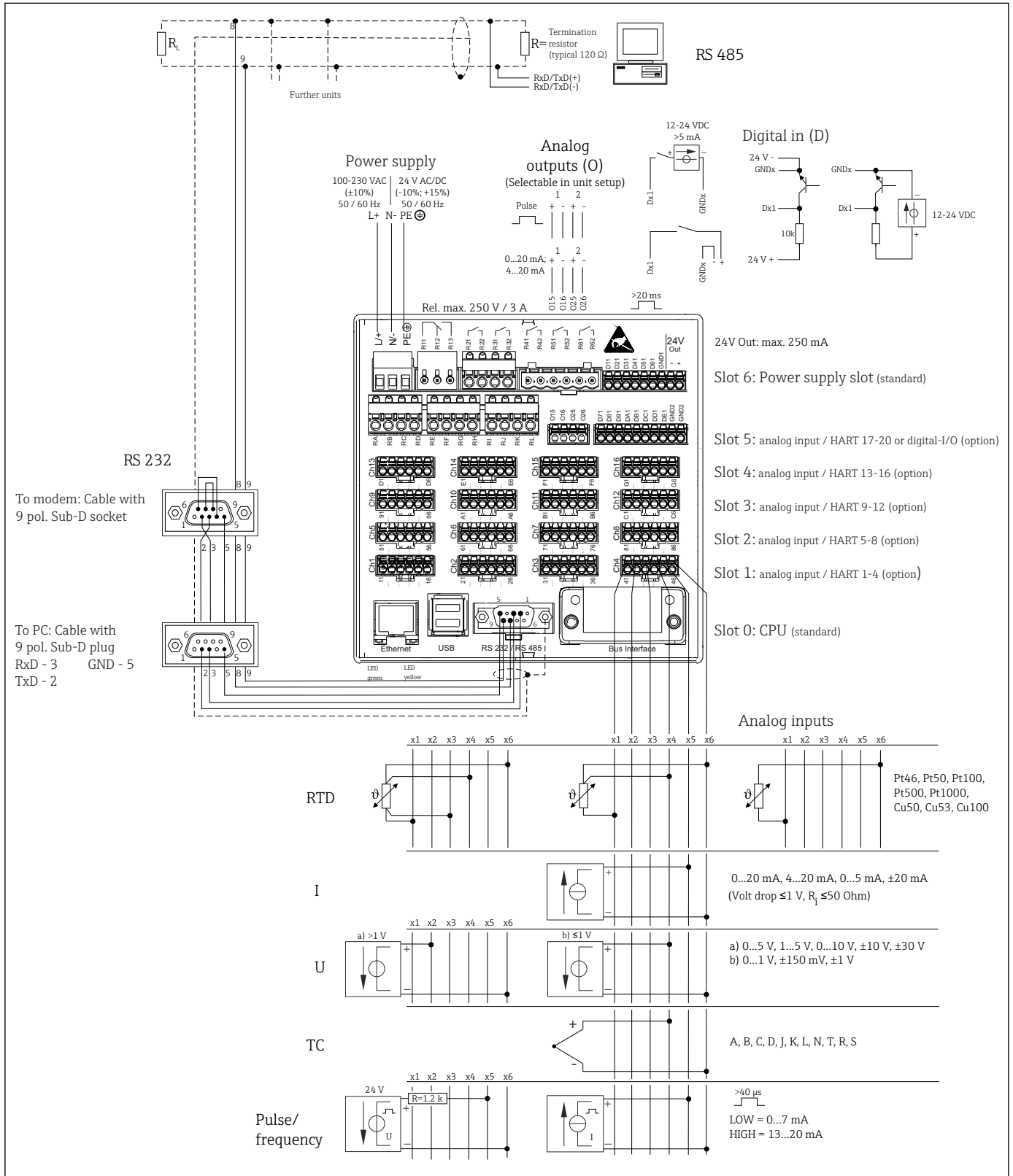

A0026669-EN

2 For connection examples of the HART® inputs (optional), see the Operating Instructions

Supply voltage (power unit, slot 6)

Power unit type	Terminal		
100-230 VAC	L+	N-	PE
	Phase L	Zero conductor N	Ground
24 V AC/DC	L+	N-	PE
	Phase L or +	Zero conductor N or -	Ground

Relay (power unit, slot 6)

Type	Terminal (max. 250 V, 3 A)				
Alarm relay 1	R11	R12	R13		
	Changeover contact	Normally closed contact (NC) ¹⁾	Normally open contact (NO) ²⁾		
Relay 2 to 6				Rx1	Rx2
				Switching contact	Normally open contact (NO) ²⁾

- 1) NC = normally closed (breaker)
- 2) NO = normally open (maker)

i The open or close function (= activation or deactivation of the relay coil) in a limit event can be configured in the setup: "Setup -> Advanced setup -> Outputs -> Relay -> Relay x". However, in the event of a power failure, the relay adopts its quiescent switch state regardless of the setting programmed.

Digital inputs; auxiliary voltage output (power unit, slot 6)

Type	Terminal			
Digital input 1 to 6	D11 to D61	GND1		
	Digital input 1 to 6 (+)	Ground (-) for digital inputs 1 to 6		

Type	Terminal			
Auxiliary voltage output, not stabilized, max. 250 mA			24V Out -	24V Out +
			- Ground	+ 24V (±15%)

i If the auxiliary voltage is to be used for the digital inputs, the **24 V out -** terminal of the auxiliary voltage output must be connected with the **GND1** terminal.

Analog inputs (slot 1-5)

The first digit (x) of the two-digit terminal number corresponds to the associated channel:

Type	Terminal					
	x1	x2	x3	x4	x5	x6
Current/pulse/frequency input ¹⁾					(+)	(-)
Voltage > 1V		(+)				(-)
Voltage ≤ 1V				(+)		(-)
Resistance thermometer RTD (2-wire)	(A)					(B)
Resistance thermometer RTD (3-wire)	(A)			b (sense)		(B)
Resistance thermometer RTD (4-wire)	(A)		a (sense)	b (sense)		(B)
Thermocouples TC				(+)		(-)

1) If a universal input is used as a frequency or pulse input, a series resistor must be used in series connection with the voltage source. Example: 1.2 kΩ series resistor at 24 V

HART® inputs (slot 1-5)

The first digit (x) of the two-digit terminal number corresponds to the associated channel:

Type	Terminal					
	x1	x2	x3	x4	x5	x6
HART® (4 to 20 mA)	SHD	H_1	H_2	R _{com}	I+	I-

- i** A 250 Ω communication resistor (load) is installed on the device side between terminals x4 and x5.
- A 10 Ω resistor (shunt) is installed on the device side at the current input between terminals x5 and x6.
- Terminals x2 and x3 (H_1 and H_2) are jumpered internally.
- The internal HART® modem is located between terminals x2/x3 and x6.

Relay extension (digital card, slot 5)

Type	Terminal (max. 250 V, 3 A)			
Relay 7, 8	RA	RB	RC	RD
Relay 9, 10	RE	RF	RG	RH
Relay 11, 12	RI	RJ	RK	RL
	Switching contact	Normally open contact ⁽¹⁾	Switching contact	Normally open contact ⁽²⁾

- 1) NO
- 2) NO

i The open or close function (= activation or deactivation of the relay coil) in a limit event can be configured in the setup: "Setup -> Advanced setup -> Outputs -> Relay -> Relay x". However, in the event of a power failure, the relay adopts its quiescent switch state regardless of the setting programmed.

Analog outputs (digital card, slot 5)

Type	Terminal			
Analog output 1-2	O15	O16	O25	O26
	Analog output 1 (+)	Ground, analog output 1 (-)	Analog output 2 (+)	Ground, analog output 2 (-)

Extension of digital inputs (digital card, slot 5)

Type	Terminal		
Digital input 7 to 14	D71 to DE1	GND2	GND2
	Digital input 7 to 14 (+)	Ground (-) for digital inputs 7 to 14	Ground (-) for digital inputs 7 to 14

i If the auxiliary voltage is to be used for the digital inputs, the **24 V out** - terminal of the auxiliary voltage output (power unit, slot 6) must be connected with the **GND2** terminal.

Device plugs

- Panel-mounted device/DIN rail version: connected to mains via plug-in screw terminals with reverse polarity protection
- Desktop version (option): connected to mains via IEC connector

Overvoltage protection

To avoid high-energy transients on long signal cables, connect a suitable surge arrester upstream (e.g., E+H HAW562) in series upstream.

Cable specifications

Cable specification, spring terminals

All connections on the rear of the device are designed as pluggable screw or spring terminal blocks with reverse polarity protection. The spring terminals are unlocked with a slotted screwdriver (size 0).

Note the following when connecting:

- Wire cross-section, auxiliary voltage output, digital I/O and analog I/O: max. 1.5 mm² (14 AWG) (spring terminals)
- Wire cross-section, mains: max. 2.5 mm² (13 AWG) (screw terminals)
- Wire cross-section, relays: max. 2.5 mm²(13 AWG) (spring terminals)
- Stripping length: 10 mm (0.39 in)

i No ferrules must be used when connecting flexible wires to spring terminals.

Shielding and grounding

Optimum electromagnetic compatibility (EMC) can only be guaranteed if the system components and the cables - both sensor and communication cables - are shielded and the shielding forms as complete a cover as possible. A shielded cable must be used for sensor cables that are longer than 30 m (100 ft). A shield coverage of 90% is ideal. Make sure that the communication cables and sensor cables do not cross when routing them. Connect the shielding as often as possible to the reference ground to ensure optimum EMC protection for the different communication protocols and the connected sensors.

To comply with requirements, three different types of shielding are possible:

- Shielding at both ends
- Shielding at one end on the supply side with capacitance termination at the device
- Shielding at one end on the feed side

The best results are achieved in installations with shielding at one end on the supply side (without capacitance termination at the device). Appropriate internal device wiring measures must be taken to allow unrestricted operation when EMC interference is present. These measures have been taken into account for this device. Operation in the event of disturbance variables as per NAMUR NE2.1 is thus guaranteed.

Observe national installation requirements and guidelines during installation. Where there are large differences in potential between the individual grounding points, only one point of the shielding is connected directly with the reference ground.

i If the shielding of the cable is grounded at more than one point in systems without potential matching, mains frequency equalizing currents can occur. These can damage the signal cable and significantly impact signal transmission. In such cases, the shield of the signal cable should be grounded on one side only and must not be connected to the ground terminal of the housing. The unconnected shield must be insulated.

Connection data interface, communication

USB interfaces:

1 x USB port type A (host) on the front of device (only for version with navigator and front interfaces)

A USB 2.0 port is available on a shielded USB-A socket at the front of the device. A USB memory stick, for example, can be connected to this port as a storage medium. An external keyboard or mouse for device operation, a USB hub, a barcode reader, or a printer (PCL5c or higher) can also be connected.

1 x USB port type B (function) on the front of device (only for version with navigator and front interfaces)

A USB 2.0 port is available on a shielded USB-B socket at the front of the device. This can be used to connect the device for communication with a laptop, for example.

2 x USB port type A (host) on the rear of the device (standard)

Two USB 2.0 ports are available on shielded USB-A sockets at the rear of the device. A USB memory stick, for example, can be connected to these ports as a storage medium. An external keyboard or mouse for device operation, a USB hub, a barcode reader, or a printer (PCL5c or higher) can also be connected.

- i**
 - USB 2.0 is compatible with USB 1.1 or USB 3.0, i.e. communication is possible.
 - The assignment of the USB interfaces complies with the standard such that shielded standard cables with a maximum length of 3 meters (9.8 ft) can be used here.
 - The USB devices are detected by the "plug-and-play" function. If several devices of the same type are connected, only the USB device that was connected first is available.
 - A maximum of 8 external USB devices (incl. USB hub) can be connected if they do not exceed the maximum load of 500 mA. If overloaded, the corresponding USB devices are automatically disabled. An active USB hub can be used for higher power ratings.

Reference list for USB printers:

HP Color LaserJet CP1515n, HP Color LaserJet Pro CP1525n, ECOSYS P6021cdn.

i The printer must support PCL5c (or higher). GDI printers are not supported!

Reference list for USB barcode readers:

Datalogic Gryphon D230; Metrologic MS5100 Eclipse Series; Symbol LS2208, Datalogic Quickscan 1, Godex GS220, Honeywell Voyager 9590.

Ethernet interface (standard):

Ethernet interface on back, 10/100 Base-T, plug type RJ45. The Ethernet interface can be used to integrate the device via a hub or switch into a PC network (TCP/ IP Ethernet). A standard patch cable (e.g., CAT5E) can be used for the connection. Using DHCP, the device can be fully integrated into an existing network without the need for additional configuration. The device can be accessed from every PC in the network. Normally only the automatic assignment of the IP address must be configured at the client. When the device is started, it can automatically retrieve the IP address, subnet mask and gateway from a DHCP server. If a DHCP is not used, these settings must be made directly in the device (depends on the specific network). Two Ethernet function LEDs are located on the rear of the device.

The following functions are implemented:

- Data communication with PC software (analysis software, configuration software, OPC server)
- Web server
- WebDAV (Web-based Distributed Authoring and Versioning) is an open standard for the provisioning of files via the HTTP protocol. The data saved on the device's SD card can be read out using a PC. A web browser or a WebDAV client can be selected as the network drive for this on the PC side.

Requirements with regard to a network printer:

Network printer reference list:

HP Color LaserJet CP1515n, HP Color LaserJet Pro CP1525n, ECOSYS P6021cdn.



The printer must support PCL5c (or higher). GDI printers are not supported!

Ethernet Modbus TCP master (option):

As a Modbus master, the device can interrogate other Modbus slaves via Ethernet. The Modbus TCP master can be operated in parallel with the Profibus DP slave, Modbus RTU/TCP slave or PROFINET I/O Device.

Up to 40 analog inputs can be transmitted via Modbus and stored in the device.

Ethernet Modbus TCP slave (option):

Connection to SCADA systems (Modbus master).

Up to 40 analog inputs and 20 (14 real + 6 virtual) digital inputs can be transmitted via Modbus and stored in the device.

Serial RS232/RS485 interface:

A combined RS232/RS485 connection is available on a shielded SUB D9 socket at the rear of the device. This can be used for data transfer and to connect a modem. For communication via modem, we recommend an industrial modem with a watchdog function.

- The following baud rates are supported: 9600, 19200, 38400, 57600, 115200
- Max. line length with shielded cable: 2 m (6.6 ft) (RS232), or 1000 m (3281 ft) (RS485)



Only one interface can be used at any one time (RS232 or RS485).

Modbus RTU master (option):

As a Modbus master, the device can interrogate other Modbus slaves via RS485. The Modbus RTU master can be operated in parallel with the Profibus-DP slave, PROFINET I/O Device or Modbus TCP slave.

Up to 40 analog inputs can be transmitted via Modbus and stored in the device.

Modbus RTU slave (option):

The device can be interrogated as a Modbus slave by another Modbus master via RS485.

Up to 40 analog inputs and 20 (14 real + 6 virtual) digital inputs can be transmitted via Modbus and stored in the device.



A Modbus RTU master and RTU slave cannot be operated in parallel.

Remote interrogation with analog or GSM/GPRS wireless modem:

Analog modem:

An analog modem for industrial use (e.g., Devolo or WESTERMO), which is connected to the RS232 interface with a special modem cable (see accessories → 30), is recommended.

GSM/GPRS wireless modem:

A GSM/GPRS wireless modem for industrial use (e.g., Cinterion, INSYS or WESTERMO, incl. antenna and power unit), which is connected to the RS232 interface with a special modem cable (see accessories → 30), is recommended.

Important: the wireless modem needs a SIM card and data transfer subscription. In addition, it must be possible to deactivate the PIN prompt.



If the web server is operated via a wireless modem, this may result in high provider costs as data are transmitted continuously.

AnyBus® interface (CPU card, slot 0, optional)

PROFIBUS-DP slave:

The device can be integrated into a fieldbus system as per the PROFIBUS-DP standard by means of the PROFIBUS-DP interface. Up to 40 analog inputs and 20 (14 real + 6 virtual) digital inputs can be

transmitted via PROFIBUS-DP and stored in the device. Bidirectional communication with cyclic data transfer is possible. Connection via Sub-D socket.

Baud rate: maximum 12 Mbit/s

EtherNet/IP adapter (slave):

Up to 40 analog inputs and 20 (14 real + 6 virtual) digital inputs can be transmitted via EtherNet/IP and stored in the device. The built-in module corresponds to I/O server category (Level 2). It has an integrated 2-port switch, thereby supporting EtherNet/IP communication in line or ring topologies. Connection via 2 RJ45 standard sockets.

PROFINET I/O device:

Up to 40 analog inputs and 20 (14 real + 6 virtual) digital inputs can be transmitted via PROFINET IO and stored in the device. The 2-port module for PROFINET IO meets compliance class B. The integrated switch enables communication in line or ring topologies without an additional external switch. Connection via 2 RJ45 standard sockets.

Performance characteristics

Response time	Input	Output	Time [ms]
	Current, voltage, pulse	Relays, OC, analog output	≤ 550
RTD	Relays, OC, analog output	≤ 1150	
TC ¹⁾	Relays, OC, analog output	≤ 1550	
Cable open circuit detection, current input	Relays, OC, analog output	≤ 1150	
Sensor error RTD, TC	Relays, OC, analog output	≤ 5000	
Digital input	Relays, OC, analog output	≤ 350	
HART input	Relays, OC, analog output	Non-deterministic	

1) If internal measuring point temperature compensation is used, otherwise values as for voltage

Reference operating conditions	Reference temperature	25 °C (77 °F) ±5 K
	Warm-up period	120 min.
	Humidity	20 to 60 % rel. humidity

Hysteresis Can be configured for limit values in the setup

Long-term drift As per IEC 61298-2: max. ±0.1%/year (of measuring range)

Mounting

Panel mounting: mounting location and installation dimensions

The device with a display is designed for use in a panel.



The device must be installed in a pressurized enclosure system for operation in the hazardous area. To ensure safe installation, it is essential to follow the installation instructions for the cabinet and the installation instructions in the Ex-related Safety Instructions (XA).

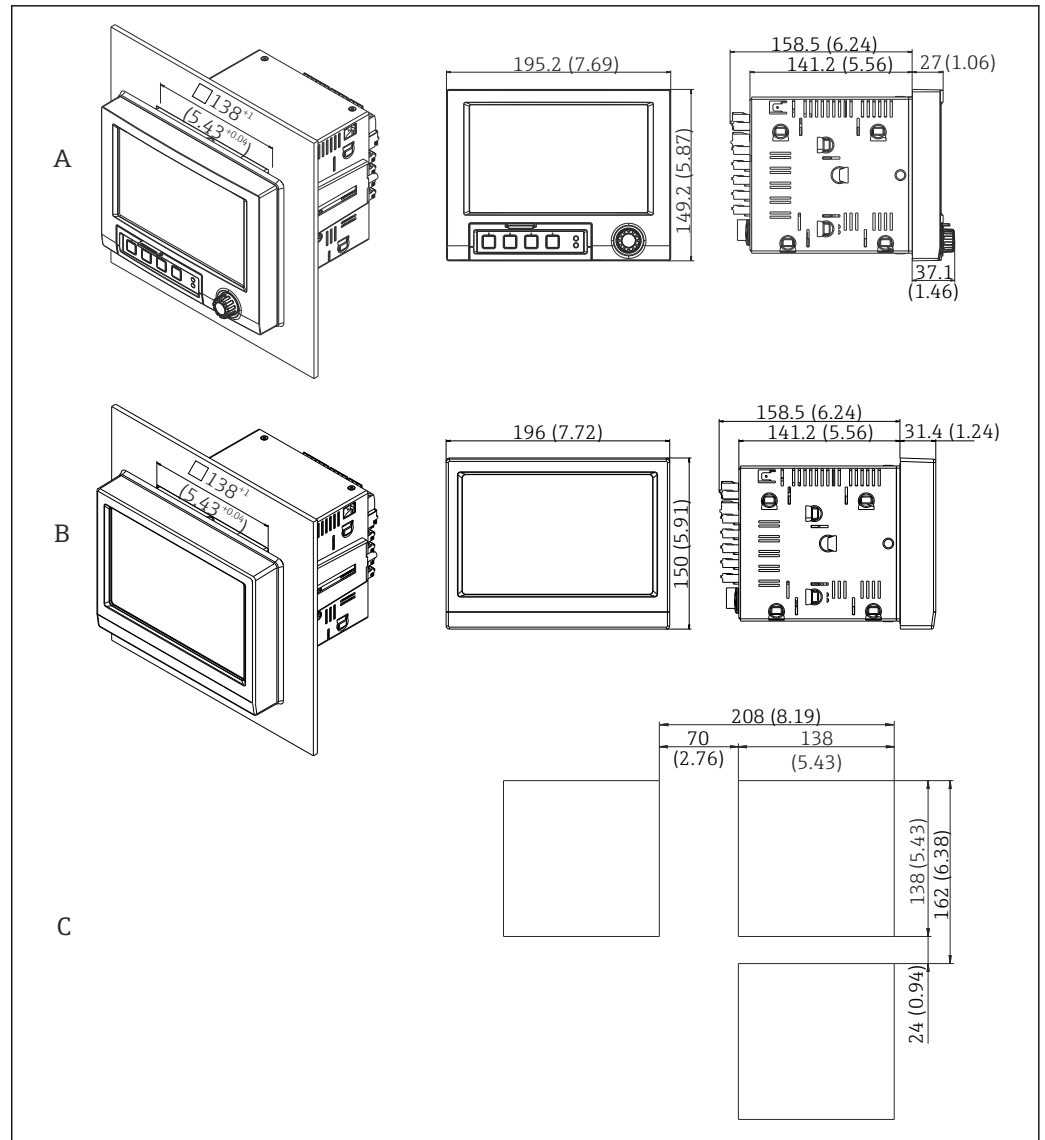

A0024610

3 Panel mounting and dimensions in mm (in).

- A Version with navigator and front interfaces
- B Version with stainless steel front and touchscreen
- C Grid dimensions of panel cutouts for multiple devices

Dimensions

- Installation depth (excluding terminal cover): approx. 159 mm (6.26 in) for device incl. terminals and fastening clips.
- Installation depth including terminal cover (option): approx. 198 mm (7.8 in)
- Panel cutout: 138 to 139 mm (5.43 to 5.47 in) x 138 to 139 mm (5.43 to 5.47 in)
- Panel thickness: 2 to 40 mm (0.08 to 1.58 in)
- viewing angle range: 50° in all directions from the display central axis
- A minimum distance of 12 mm (0.47 in) between the devices must be observed if aligning the devices vertically above one another or horizontally beside one another.
- The grid dimension of the panel cutouts for multiple devices must be at least 208 mm (8.19 in) horizontally and at least 162 mm (6.38 in) vertically (tolerance not considered).
- Securing to DIN 43 834

Mounting location and installation dimensions for the DIN rail version

The device without a display is designed for DIN rail mounting.

i The DIN rail device is **not** approved for operation in the hazardous area.

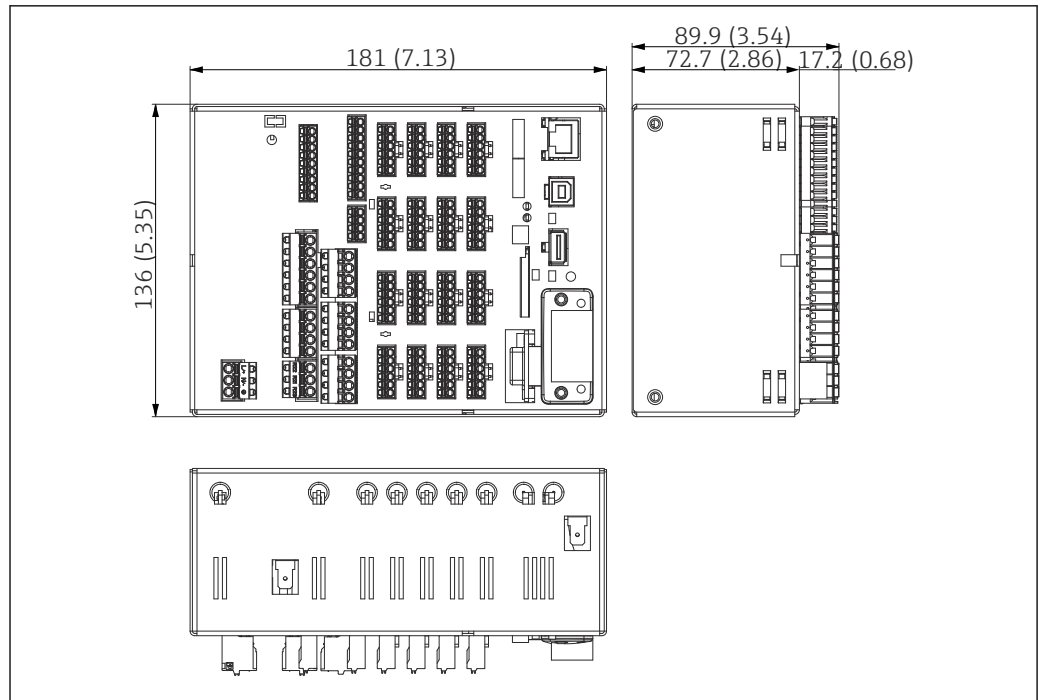

A0036528

4 DIN rail version, dimensions in mm (in).

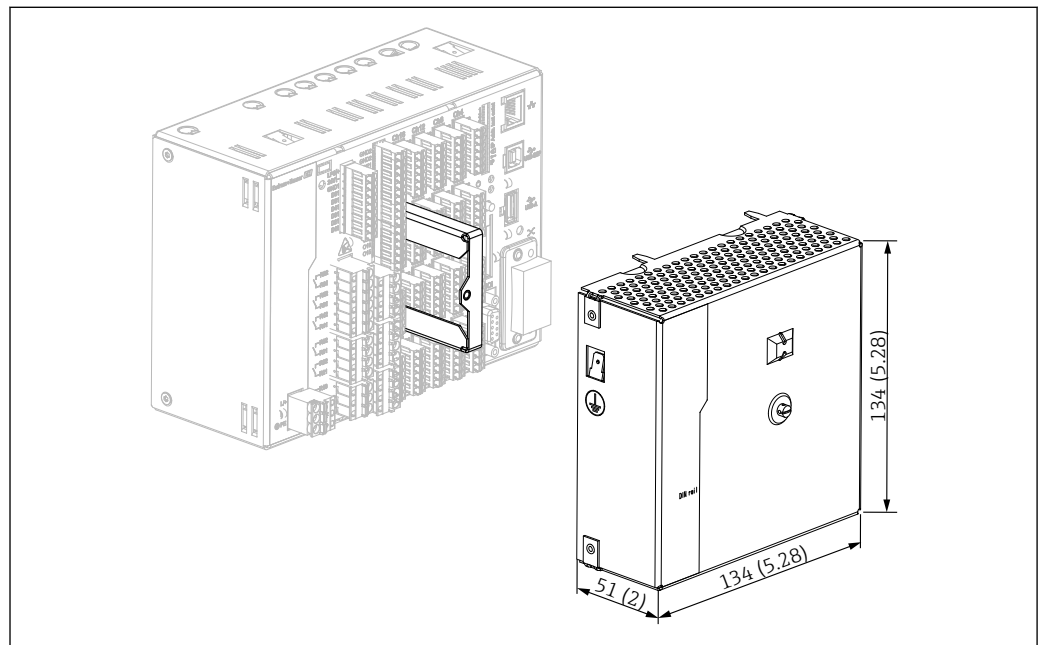

A0046633

5 Terminal cover, DIN rail version, dimensions in mm (in)

Dimensions

- Installation depth: approx. 90 mm (3.54 in) for device incl. terminals (w/o terminal cover).
- Mounted on DIN rail as per IEC 60715
- The devices can be arranged horizontally beside one another without clearance between the devices.

Field housing assembly and design (optional)

As an option, the panel-mounted device can be ordered ready-mounted in a field housing with IP65. Dimensions (B x H x D) approx.: 320 mm (12.6 in) x 320 mm (12.6 in) x 254 mm (10 in)

Desktop housing assembly and design (optional)	As an option, the panel-mounted device can be ordered ready-mounted in a desktop housing. Dimensions (B x H x D) approx.: 293 mm (11.5 in) x 188 mm (7.4 in) x 213 mm (8.39 in) (dimensions with bracket, feet and installed device)
---	--

Environment

Ambient temperature range	-10 to +50 °C (14 to 122 °F)
Storage temperature	-20 to +60 °C (-4 to +140 °F)
Relative humidity	5 to 85 %, non-condensing
Operating altitude	< 2 000 m (6 561 ft) above MSL
Climate class	To IEC 60654-1: Class B2
Electrical safety	Class I equipment, overvoltage category II Pollution degree 2
Degree of protection	Degree of protection: <ul style="list-style-type: none"> ■ Panel-mounted device: Front: IP65, NEMA Type 4 incl. / Rear: IP20 ■ Version with stainless steel front and touchscreen: Front: IP65, NEMA Type 4X incl. (approved by UL)/Rear: IP20 ■ DIN rail Version: NEMA Type 1, IP20
Electromagnetic compatibility	EMC in accordance with all relevant requirements of the IEC/EN 61326 series and NAMUR NE 21. For details, refer to the Declaration of Conformity. <ul style="list-style-type: none"> ■ Interference immunity: as per IEC/EN 61326 series (industrial environment)/NAMUR NE 21 Maximum measurement error <1% of measuring range ■ Interference emissions: as per IEC 61326-1 Class A

Mechanical construction

Design and dimensions	Information about design and dimensions →  20
Weight	<ul style="list-style-type: none"> ■ Panel-mounted device with navigator and front interfaces (with maximum configuration): approx. 2.7 kg (5.9 lbs) ■ Panel-mounted device with stainless steel front and touchscreen (with maximum configuration): approx. 3.2 kg (7 lbs) ■ DIN rail version: approx. 1.8 kg (3.97 lbs) ■ Desktop housing (excluding device): approx. 2.3 kg (5 lbs) ■ Field housing (excluding device): approx. 4 kg (8.8 lbs)

Materials	Panel-mounted device with navigator and front interfaces	
	Front frame	Zinc die cast GD-Z410, powder-coated
	Display glass	Transparent Makrolon® plastic (FR clear 099) UL94-V2
	Flap; jog/shuttle dial ("Navigator")	Plastic ABS UL94-V2
	Membrane keypad	Polyester membrane PC-ABS UL94-V2
	Intermediate frame (front towards control panel)	Plastic PA6-GF20 UL94-V2

Panel-mounted device with navigator and front interfaces	
Seal towards panel wall; seal in flap; seal towards navigator	Rubber EPDM 70 Shore A
Casing; rear panel	Galvanized sheet steel St 12 ZE

Panel-mounted device with stainless steel front and touchscreen	
Front frame	AISI 316L
Display glass	6 mm single-pane safety glass (soda-lime glass)
Intermediate frame (front towards control panel)	Plastic PA6-GF20 UL94-V2
Seal towards control panel wall	Rubber EPDM 70 Shore A
Window seal between front frame and glass	Rubber EPDM 60 Shore A
Casing; rear panel	Galvanized sheet steel St 12 ZE

DIN rail version	
Retaining bracket	EN AW 6060 T66 / AlMgSi0.5 F22
Casing; front	Galvanized sheet steel St 12 ZE

Designation	Short formula	Properties
AISI 316L (corresponds to 1.4404 or 1.4435)	X2CrNiMo17-13-2, X2CrNiMo18-14-3	Austenitic, stainless steel High corrosion resistance in general



All materials are silicone-free.

Materials of desktop housing

- Housing half-panels: sheet steel, electrolytically plated (powder-coated)
- Side sections: aluminum extruded section (powder-coated)
- Section ends: colored polyamide
- Feet: colored polyamide, fiber-glass reinforced

Field housing materials

- Housing (front frame, door, base frame, side parts): thermoplastic polycarbonate PC
- Front panel and wall mounting: chrome-nickel stainless steel 1.4301 V2A

Display and operating elements

Operation concept



The description for local operation does not apply for the DIN rail version, as this has neither a display screen nor operating elements. The description for remote configuration applies for all versions.

The device can be operated directly on site, or via remote configuration with the PC via interfaces and operating tools (web server, configuration software).

Web server

A web server is integrated into the device. The web server offers the following range of functions:

- Easy configuration without additional installed software
- Instantaneous value display and diagnostics information
- Display of current measured value curves via web browser (remote control)
- Display of historical measured data in numerical format or as a curve
- Display of events and logbook entries

- Loading/saving of device configuration
- Device firmware update
- Printout of device configuration

Integrated Operating Instructions

Thanks to the device's simple operating concept, it is possible to commission the device for many applications without a hard copy of the Operating Instructions. The device has an integrated help function and displays operating instructions directly on the monitor.

Languages

The following languages can be selected in the operating menu: German, English, Spanish, French, Italian, Dutch, Swedish, Polish, Portuguese, Czech, Russian, Japanese, Chinese (Traditional), Chinese (Simplified)

Local operation

Display elements on panel-mounted device

Type

Wide-screen TFT color graphic display (optionally with touch control)

Size (diagonal screen measurement)

178 mm (7")

Resolution

Wide VGA 384,000 pixels (800 x 480 pixels)

Backlight

50,000 h half-life (= half brightness)

Number of colors

262,000 viewable colors, 256 colors used

Viewing angle

Max. viewing angle range: 50° in all directions from the display central axis

Screen displays

- Users can choose between black and white for the background color.
- Active channels can be assigned to up to 10 groups. These groups can be given a name e.g., "Temp. boiler 1" or "Daily averages" so that they can be uniquely identified.
- Scales linear or logarithmic
- Measured value history: Quick retrieval of historic data with zoom function
- Pre-formatted display formats, such as horizontal or vertical curves, instrument display, circular chart, process screen, bar graph or digital display.

Measured value display and operating elements

Measured value display and operating elements on panel-mounted device

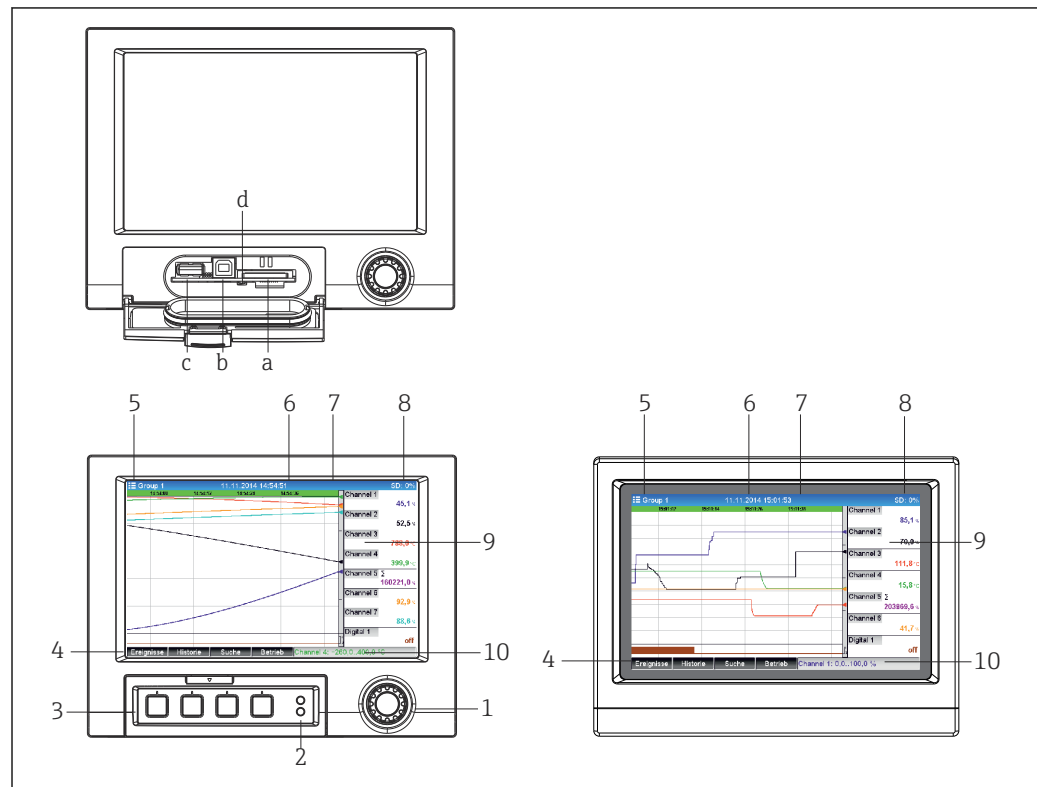

A0024709

6 Device front (left: version with navigator and front interfaces; right: version with stainless steel front and touchscreen)

Item no.	Operating function (display mode = display of measured values) (Setup mode = operation in the Setup menu)
a	Slot for SD card
b	USB-B socket "Function", e.g., to connect to a PC or laptop
c	USB-A socket "Host", e.g., for USB memory stick, external keyboard, barcode reader or printer
d	LED at SD slot. Yellow LED lit or flashing when the device is accessing the SD card. Do not remove the SD card if the LED is lit or flashing! Risk of data loss!
1	"Navigator": Jog/shuttle dial for operating with additional press/hold function. In display mode: Turn the dial to switch between the various signal groups. Press the dial to display the main menu. In setup mode and in a selection menu: Turn the dial anticlockwise to move the bar or the cursor up or to the left, changes the parameter. Turning clockwise moves the bar or cursor down or clockwise, changes parameter. Press = select highlighted function, start parameter change (ENTER key).
2	Functions of LED indicators (according to NAMUR NE44:) <ul style="list-style-type: none"> ■ Green LED (top) lit: power supply OK ■ Red LED (bottom) flashing: maintenance required, caused by external factor (e.g., cable open circuit etc.), or a message/notification requiring acknowledgment is pending, calibration is running.
3	Variable "soft keys" 1-4 (from left to right)
4	Function indicator of "soft keys"
5	In display mode: current group name, type of analysis; In setup mode: name of the current operating item (dialog title)
6	In display mode: displays current date/time In setup mode: --
7	In display mode: user ID (if function is active) In setup mode: --

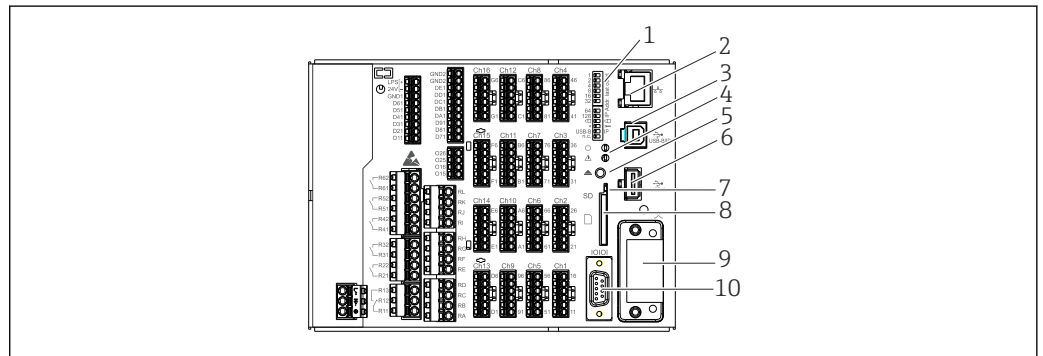

Item no.	Operating function (display mode = display of measured values) (Setup mode = operation in the Setup menu)
8	In display mode: alternating display indicating the percentage space on the SD card or USB stick that has already been used. Status symbols are also displayed in alternation with the memory information (e.g., simulation mode, data storage active, operation locked, batch active) In setup mode: the current "direct access" operating code is displayed
9	In display mode: window for measured value display (e.g., curve display). Displays the current measured values and the status in the event of an error/alarm condition. In the case of counters, the type of counter is displayed as a symbol.  If a measuring point has limit value status, the corresponding channel identifier is highlighted in red (quick detection of limit value violations). During a limit value violation and device operation, the acquisition of measured values continues uninterrupted.
9	In setup mode: displays the operating menu
10	In display mode: alternating status display (e.g., set zoom range) of the analog or digital inputs in the appropriate color of the channel. In setup mode: different information is displayed here depending on the display type.

Operating elements of the DIN rail version



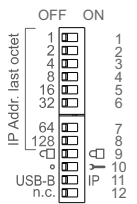

A0036811

 7 Device front of the DIN rail version

Item no.	Operating function
1	<p>DIP switches The behavior of the Ethernet interface is configured via DIP switches (left = OFF, right = ON).</p> <p> The DIN rail version is supplied with the following Ethernet settings: IP address: 192.168.1.212; subnet mask: 255.255.255.0; gateway: 0.0.0.0</p> 
2	Ethernet interface
3	USB-B socket "Function", e.g., to connect to a PC or laptop
4	<p>Functions of LED indicators (according to NAMUR NE44:)</p> <ul style="list-style-type: none"> Green LED (top) lit: power supply OK Red LED (bottom) flashing: maintenance required, caused by external factor (e.g., cable open circuit etc.), or a message/notification requiring acknowledgment is pending, calibration is running.
5	<p>Cyclic storage is completed via the "Safe SD card removal" button, the LED (d) goes out. The SD card can now be removed.</p> <p> If the SD card is not removed within 5 minutes, the write cycles start again.</p>

A0036815

Item no.	Operating function
6	<p>USB-A socket "Host", e.g., for USB memory stick or printer If a USB stick is inserted, data that have not yet been saved are copied to the stick automatically. The red LED on the USB socket flashes while the data are being copied to the stick.</p> <p> Do not remove the USB stick when the red LED is flashing! Risk of data loss!</p> <p>If an error occurs (e.g., USB stick full or defective), the red LED is lit constantly. Remove the USB stick and replace it.</p>
7	<p>LED at SD slot. Yellow LED lit or flashing when the device is accessing the SD card.</p> <p> Do not remove the SD card if the LED is lit or flashing! Risk of data loss!</p>
8	Slot for SD card
9	Anybus interface (option)
10	Serial RS232/RS485 interface

Remote operation

Device access via operating tools

Device configuration and measured value retrieval can also be done via interfaces. The following operating tools are available for this purpose:

Operating tool	Functions	Access via
Field Data Manager (FDM) analysis software, SQL database support	<ul style="list-style-type: none"> ▪ Export of saved data (measured values, analyses, event logbook) ▪ Visualization and processing of saved data (measured values, analyses, event logbook) ▪ Safe archiving of exported data in an SQL database 	RS232/RS485, USB, Ethernet
Web server (integrated into the device; access via browser)	<ul style="list-style-type: none"> ▪ Display of current and historical data and measured value curves via the web browser ▪ Easy configuration without additional installed software ▪ Remote access to device and diagnostic information 	Ethernet, or Ethernet over USB
OPC server (optional)	<p>The following instantaneous values can be provided:</p> <ul style="list-style-type: none"> ▪ Analog channels ▪ Digital channels ▪ Mathematics ▪ Totalizer 	RS232/RS485, USB, Ethernet
"FieldCare/ DeviceCare" configuration software	<ul style="list-style-type: none"> ▪ Device configuration ▪ Loading and saving of device configurations (upload/download) ▪ Documentation of the measuring point 	USB, Ethernet

Certificates and approvals

 For the approvals available, see the Configurator on the specific product page: www.endress.com → (search for device name)

CE mark

The product meets the requirements of the harmonized European standards. As such, it complies with the legal specifications of the EC directives. The manufacturer confirms successful testing of the product by affixing to it the CE-mark.

Electronic recording/ electronic signature

FDA 21 CFR Part 11

The device meets the requirements of the "Food and Drug Administration" for electronic recording/
electronic signature.

Certifications

- HART® certification (HCF)
- PROFINET certification
- EtherNet/IP certification

Other standards and guidelines

- IEC 60529:
Degrees of protection provided by enclosures (IP code)
- IEC/EN 61010-1:
Safety requirements for electrical equipment for measurement, control, and laboratory use
- IEC/EN 61326 series:
Electromagnetic compatibility (EMC requirements)

Ordering information

 The hazardous area version (Ex version) is only available in conjunction with the stainless steel front and touch control.

Ordering information

Detailed ordering information is available from your nearest sales organization www.addresses.endress.com or in the Product Configurator at www.endress.com:

1. Select the product using the filters and search field.
2. Open the product page.
3. Select **Configuration**.

Scope of delivery

The scope of delivery of the device comprises:

- Device (with terminals, according to order)
- Panel-mounted device: 2 screw fastening clips
- Version with navigator and front interfaces or DIN rail version: USB cable
- Panel-mounted device: sealing rubber towards the panel wall
- "Industrial Grade" SD card, industry standard:
 - Panel-mounted device with navigator and front interfaces: card is located in the SD slot behind the flap on the front of the device (optional).
 - Panel-mounted device with stainless steel front and touchscreen: card is located in the device and cannot be replaced or retrofitted.
 - DIN rail version: card is located in the SD slot (optional).
- "Field Data Manager (FDM)" analysis software (Essential, Demo or Professional version, depending on order)
- Delivery note
- Multilingual Brief Operating Instructions as hard copy
- Hard copy of Ex Safety Instructions (optional)

Accessories



The accessories currently available for the product can be selected at www.endress.com:

1. Select the product using the filters and search field.
2. Open the product page.
3. Select **Spare parts & Accessories**.

Device-specific accessories

Description	Order no.
"Industrial Grade" SD card, industry standard, 1GB	71213190
Field Data Manager analysis software with SQL database support (1 x workstation license, Professional version on DVD)	MS20-A5
OPC server software (full version on CD)	RXO20-11

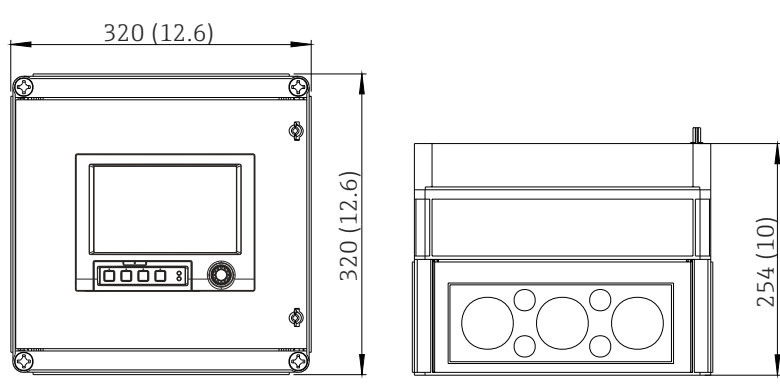
Description	Order no.
Accessories for RXU10 data manager	RXU10- _ _
Designation: Cable set RS232 for connection to PC or modem USB - RS232 converter Cable USB-A - USB-B, 1.8 m (5.9 ft) Configuration software "FieldCare Device Setup" + USB cable	RXU10-B _ RXU10-E _ RXU10-F _ RXU10-G _

Description	Order no.
Field housing IP65 (for panel-mounted device)	RXU10-H _
 <p style="text-align: center;">320 (12.6)</p> <p style="text-align: center;">320 (12.6)</p> <p style="text-align: center;">254 (10)</p> <p style="text-align: right; font-size: small;">A0024766</p>	
 8 <i>Dimensions in mm (in)</i>	

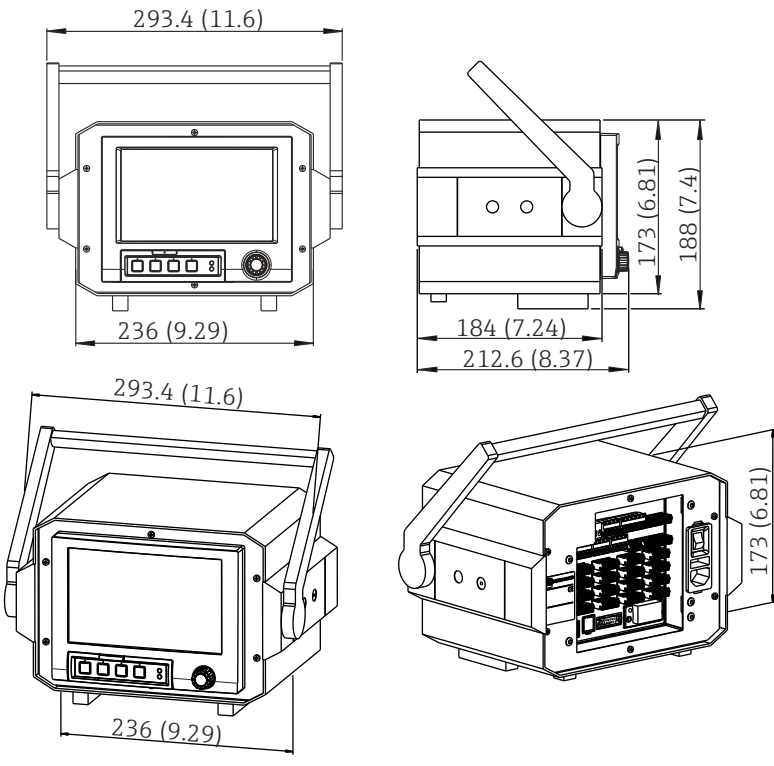
Description	Order no.
<p>Desktop housing (for panel-mounted device), cable with Schuko plug Desktop housing (for panel-mounted device), cable with US plug Desktop housing (for panel-mounted device), cable with Swiss plug</p>  <p>9 Dimensions in mm (in)</p>	<p>RXU10-I _ RXU10-J _ RXU10-K _</p>
<p>Version: Standard Neutral</p>	<p>RXU10- _ 1 RXU10- _ 2</p>

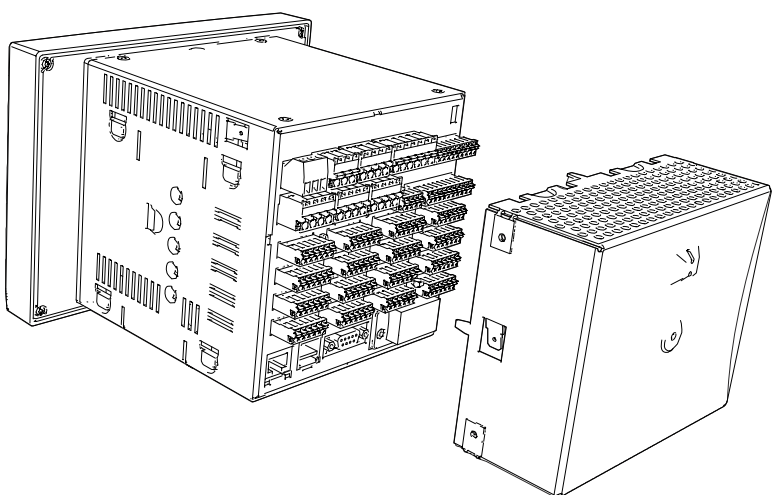
Description	Order no.
<p>Terminal cover can be sealed (for panel-mounted device) An optional terminal cover is available to prevent tampering at the device terminals and terminal temperature measurement.</p> 	<p>XPR0011-A5</p>

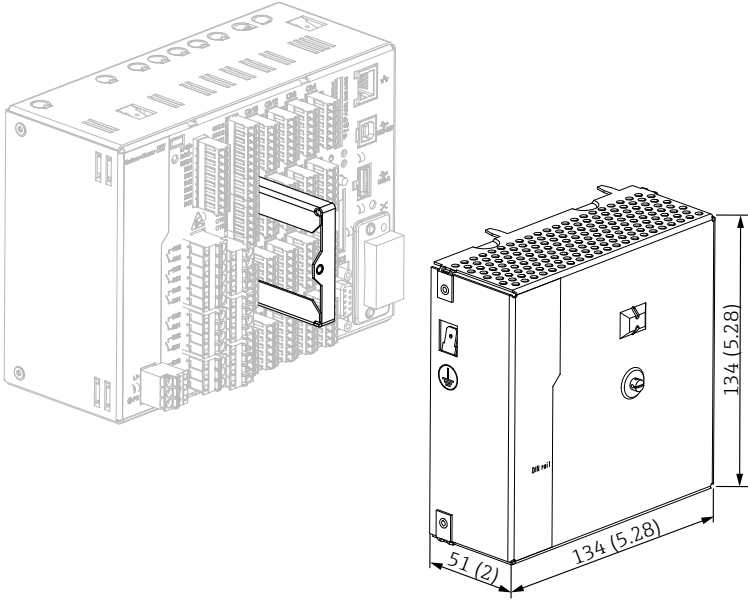
Description	Order no.
<p>Terminal cover can be sealed (for DIN rail version) An optional terminal cover is available to prevent tampering at the device terminals and terminal temperature measurement.</p> 	XPR0011-A8

Communication-specific accessories

Field Data Manager (FDM) analysis software MS20, MS21

- Field Data Manager (FDM) is a software which provides central data management and visualization. This enables the continuous, tamper-free archiving of process data, e.g. measured values and diagnostic events. "Live data" from connected devices is available. FDM saves the data in an SQL database.
- Supported databases: PostgreSQL (included in the delivery), Oracle or Microsoft SQL server.
- MS20 single-user license: Installing the software on a computer.
- MS21 multi-user license: Several simultaneous users, dependent on the number of available licenses.



Technical Information TI01022R

www.endress.com/ms20

www.endress.com/ms21

OPC DA server RXO20

The OPC DA server transmits process data such as instantaneous values or totalizers from connected Endress+Hauser field devices and provides them to the OPC clients in real time. These data can be visualized with OPC client software. Communication takes place via an RS232/RS485 interface or a TCP/IP connection. OPC is used in systems of various sizes in factory and process automation.



Technical Information TI00122R

www.endress.com/rxo20

Service-specific accessories

Software

DeviceCare SFE100

DeviceCare is an Endress+Hauser configuration tool for field devices using the following communication protocols: HART, PROFIBUS DP/PA, FOUNDATION Fieldbus, IO/Link, Modbus, CDI and Endress+Hauser Common Data Interfaces.



Technical Information TI01134S

www.endress.com/sfe100

FieldCare SFE500

FieldCare is a configuration tool for Endress+Hauser and third-party field devices based on DTM technology.

The following communication protocols are supported: HART, WirelessHART, PROFIBUS, FOUNDATION Fieldbus, Modbus, IO-Link, EtherNet/IP, PROFINET and PROFINET APL.



Technical Information TI00028S

www.endress.com/sfe500

Netilion

With the Netilion IIoT ecosystem, Endress+Hauser enables the optimization of plant performance, digitization of workflows, sharing of knowledge and improved collaboration. Drawing upon decades of experience in process automation, Endress+Hauser offers the process industry an IIoT ecosystem designed to effortlessly extract insights from data. These insights allow process optimization, leading to increased plant availability, efficiency, reliability and ultimately a more profitable plant.



www.netilion.endress.com

Field Xpert SMT50

Universal, high-performance tablet PC for device configuration.



Technical Information TI01555S

www.endress.com/smt50

Field Xpert SMT77 via WLAN

Universal, high-performance tablet PC for device configuration in Ex Zone 1 areas.



Technical Information TI01418S

www.endress.com/smt77

Online tools

Product information about the entire life cycle of the device is available at:

www.endress.com/onlinetools

System components

Surge arrester modules from the HAW product family

Surge arrester modules for DIN rail and field device mounting, for the protection of plants and measuring instruments with power supply and signal/communication lines.

More detailed information: www.endress.com

Process indicators from the RIA product family

Easily readable process indicators with various functions: loop-powered indicators for displaying 4-20 mA values, display of up to four HART variables, process indicators with control units, limit value monitoring, sensor power supply, and galvanic isolation.

Universal application thanks to international hazardous area approvals, suitable for panel mounting or field installation..

For more information, please refer to: www.endress.com

RN series active barrier

Single- or two-channel active barrier for safe separation of 0/4 to -20 mA standard signal circuits with bidirectional HART transmission. In the signal duplicator option, the input signal is transmitted to two galvanically isolated outputs. The device has one active and one passive current input; the outputs can be operated actively or passively.

For more information, please refer to: www.endress.com

Instructions for enabling a software option

Various device options can be enabled via an activation code. Available options can be ordered as an accessory and can be ordered separately. → 30. Once you place your order, you will receive instructions on how to activate the option and a code which must be entered under "**Main menu -> Expert -> System -> Device options -> Activation code**".

Documentation

The following document types are available in the Downloads area of the Endress+Hauser website (www.endress.com/downloads), depending on the product configuration:

Document type	Purpose and content of the document
Technical Information (TI)	Planning aid This document contains all the technical data on the product and provides an overview of everything that can be ordered with the product.
Brief Operating Instructions (KA)	Quick guide to obtaining the first measured value The Operating Instructions contain all the essential information about the product from incoming acceptance to initial commissioning.
Operating Instructions (BA)	Reference The Operating Instructions contain the information that is required in the various phases of the life cycle of the product: From product identification, incoming acceptance and storage, to mounting, connection, operation and commissioning through to troubleshooting, maintenance and disposal.
Description of Device Parameters (GP)	Reference for parameters The document contains detailed explanations of readable or configurable parameters in the product. The description is aimed at those who work with the product over its entire life cycle and perform specific configurations.
Safety Instructions (XA)	Safety Instructions for electrical equipment in hazardous areas are supplied with the product depending on the approval. These are an integral part of the Operating Instructions.  The nameplate indicates the Safety Instructions (XA) that are relevant to the product.
Supplementary device-dependent documentation (SD/FY)	Always comply strictly with the instructions in the relevant supplementary documentation. The supplementary documentation is an integral part of the product documentation.



www.addresses.endress.com
