

# Safety Instructions

## Micropilot

### FMR50/51/52/53/54

4-20 mA HART, 2-wire

4-20 mA HART, 2-wire, switch output (PFS)

Ex d [ia] IIC T6 Ga/Gb



Document: XA01292F-A

Safety instructions for electrical apparatus for explosion-hazardous areas



# Micropilot

## FMR50/51/52/53/54

4-20 mA HART

### Table of Contents

Associated documentation . . . . .	4
Supplementary documentation . . . . .	4
Manufacturer's certificates . . . . .	4
Extended order code . . . . .	4
Safety instructions: General . . . . .	6
Safety instructions: Special conditions . . . . .	6
Safety instructions: Installation . . . . .	6
Safety instructions: Zone 0 . . . . .	7
Temperature tables . . . . .	7
Connection data . . . . .	7

<b>Associated documentation</b>	<p>This document is an integral part of the following Operating Instructions:  BA01045F/00 (FMR50), BA01049F/00 (FMR51/52), BA01050F/00 (FMR53/54)</p> <p>The Operating Instructions pertaining to the device apply.</p>									
<b>Supplementary documentation</b>	<p>Explosion-protection brochure:  CP00021Z/11</p> <p>The Explosion-protection brochure is available:</p> <ul style="list-style-type: none"> <li>■ In the download area of the Endress+Hauser website: <a href="http://www.endress.com">www.endress.com</a> → Download → Advanced → Documentation Code: CP00021Z</li> <li>■ On the CD for devices with CD-based documentation</li> </ul>									
<b>Manufacturer's certificates</b>	<p><b>Certificate of Conformity</b></p> <p>Certificate number:  TÜV 13.2010 X</p> <p>Affixing the certificate number certifies conformity with the standards under <a href="http://www.abnt.org.br">www.abnt.org.br</a> (depending on the device version).</p> <ul style="list-style-type: none"> <li>■ ABNT NBR IEC 60079-0 :2008</li> <li>■ ABNT NBR IEC 60079-1 :2007</li> <li>■ ABNT NBR IEC 60079-11 :2009</li> <li>■ ABNT NBR IEC 60079-26 :2008</li> </ul>									
<b>Extended order code</b>	<p>The extended order code is indicated on the nameplate, which is affixed to the device in such a way that it is clearly visible. Additional information about the nameplate is provided in the associated Operating Instructions.</p> <p><b>Structure of the extended order code</b></p> <table border="0" style="margin-left: 40px;"> <tr> <td style="text-align: center;">FMR5x</td> <td style="text-align: center;">- *****</td> <td style="text-align: center;">+ A*B*C*D*E*F*G*..</td> </tr> <tr> <td style="text-align: center;">-----</td> <td style="text-align: center;">-----</td> <td style="text-align: center;">-----</td> </tr> <tr> <td style="text-align: center;">Device type</td> <td style="text-align: center;">Basic specifications</td> <td style="text-align: center;">Optional specifications</td> </tr> </table> <p>* = Placeholder</p> <p>At this position, an option (number or letter) selected from the specification is displayed instead of the placeholders.</p> <ul style="list-style-type: none"> <li>■ Basic specifications  The features that are absolutely essential for the device (mandatory features) are specified in the basic specifications. The number of positions depends on the number of features available.  The selected option of a feature can consist of several positions.</li> <li>■ Optional specifications  The optional specifications describe additional features for the device (optional features).  The number of positions depends on the number of features available.  The features have a 2-digit structure to aid identification (e.g. JA). The first digit (ID) stands for the feature group and consists of a number or a letter (e.g. J = test, certificate). The second digit constitutes the value that stands for the feature within the group (e.g. A = 3.1 material (wetted parts), inspection certificate).</li> </ul> <p>More detailed information about the device is provided in the following tables. These tables describe the individual positions and IDs in the extended order code which are relevant to hazardous locations.</p>	FMR5x	- *****	+ A*B*C*D*E*F*G*..	-----	-----	-----	Device type	Basic specifications	Optional specifications
FMR5x	- *****	+ A*B*C*D*E*F*G*..								
-----	-----	-----								
Device type	Basic specifications	Optional specifications								

## Device type: FMR50, FMR51, FMR52, FMR53, FMR54

## Basic specifications

Position	Selected option	Description
1, 2 Approval	FMR5x MC	Ex d [ia] IIC T6 Ga/Gb
3 Power Supply; Output	FMR5x A B	2-wire, 4-20 mA HART 2-wire, 4-20 mA HART, switch output (PFS)
4 Display; Operation	FMR5x A C E  L M	Without, via communication SD02 4-line, push buttons + data backup function SD03 4-line, illum., touch control + data backup function Prepared for display FHX50 + M12 connection Prepared for display FHX50 + custom connection
5 Housing	FMR51-54 B	Dual compartment, 316L (GT18)
	FMR5x C	Dual compartment, Alu coated (GT20)
7, 8 Antenna	FMR50 BM BN BR	Horn 40 mm/1½", PVDF encapsulated, -40...130 °C Horn 80 mm/3", PP cladded, -40...80 °C Horn 100 mm/4", PP cladded, -40...80 °C
	FMR51 Bx	Horn (different sizes)
	FMR52 BO BP	Horn 50 mm/2", -40...200 °C, flush mount Horn 80 mm/3", -40...200 °C, flush mount
	FMR53 Cx	Rod (different sizes)
	FMR54 Ax Bx Dx	Without Horn Horn (different sizes) Planar (different sizes)
9, 10 Seal	FMR51 A5 C1 D2 D3	Viton GLT, -40...150 °C Kalrez, -20...150 °C Graphite, -196...450 °C (HT) Graphite, -40...250 °C (XT)
	FMR54 A7 A8 B4 C2 D1 D2	Viton, -20...150 °C (Planar) Viton, -40...200 °C EPDM, -40...150 °C Kalrez, -20...200 °C, conductive media max. 150 °C Graphite, -196...280 °C (XT) Graphite, -196...400 °C (HT)
11-13 Process Connection	FMR51-54 Axx, Cxx, Kxx	Flange (different sizes)
	FMR50 GGF, RGF UAE XR0 XxG	Thread, PVDF Mounting bracket Connection, without flange/mounting bracket Slip on flange (different sizes)
	FMR51 Pxx Rxx Txx	Flange (different sizes) Thread, 316L and PVDF Tri-Clamp
	FMR52 Mxx Txx	Slotted-nut Tri-Clamp
	FMR53 RxJ RxF	Thread, 316L Thread, PVDF

## Optional specifications

ID	Selected option	Description
Ox Accessory Mounted	FMR51 OW	Horn protection, PTFE, no airpurge possible

### Safety instructions: General

- Staff must meet the following conditions for mounting, electrical installation, commissioning and maintenance of the device:
  - Be suitably qualified for their role and the tasks they perform
  - Be trained in explosion protection
  - Be familiar with national regulations
- Install the device according to the manufacturer's instructions and national regulations.
- Do not operate the device outside the specified electrical, thermal and mechanical parameters.
- Only use the device in media to which the wetted materials have sufficient durability.
- Avoid electrostatic charging:
  - Of plastic surfaces (e.g. housing, sensor element, special varnishing, attached additional plates, ..)
  - Of isolated capacities (e.g. isolated metallic plates)
- Refer to the temperature tables for the relationship between the permitted ambient temperature for the sensor and/or transmitter, depending on the range of application, and the temperature class.
- Modifications to the device can affect the explosion protection and must be carried out by staff authorized to perform such work by Endress+Hauser.

### Safety instructions: Special conditions

Permitted ambient temperature range at the electronics housing:  $-40\text{ °C} \leq T_a \leq +80\text{ °C}$ .  
Observe the information in the temperature tables.

Device type FMR50, FMR52, FMR53, FMR54 (planar, enamel)

- An antenna coated with non-conductive material can be used if avoiding electrostatic charging (e.g. through friction, cleaning, maintenance, strong medium flow).

Device type FMR51 and Optional specification, ID Ox (Accessory Mounted) = OW

- An antenna coated with non-conductive material can be used if avoiding electrostatic charging (e.g. through friction, cleaning, maintenance, strong medium flow).
- In the case of process connections made of polymeric material or with polymeric coatings, avoid electrostatic charging of the plastic surfaces.
- In the event of additional or alternative special varnishing on the housing or other metal parts:
  - Observe the danger of electrostatic charging and discharge.
  - Do not rub surfaces with a dry cloth.

### Safety instructions: Installation

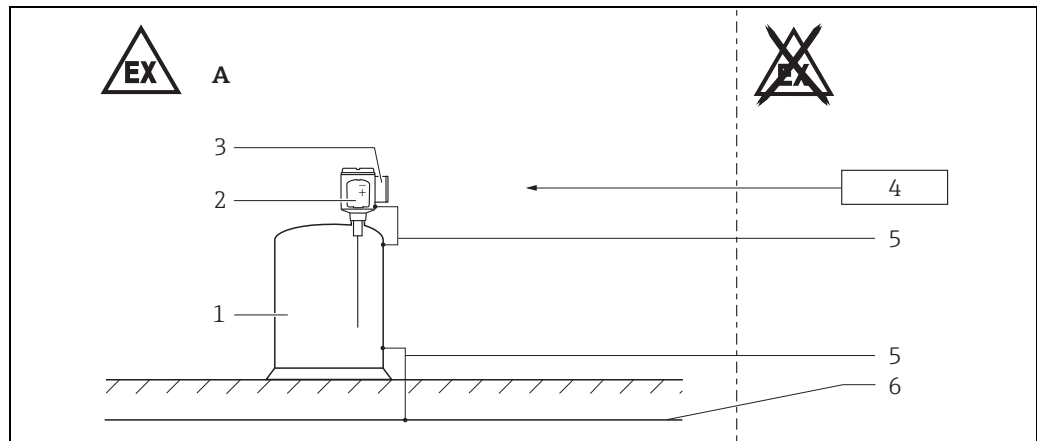

FMP5x\_02



- A** Zone 1
- 1 Tank; Zone 0, Zone 1
  - 2 Electronics compartment Ex ia; Electronic insert
  - 3 Connection compartment Ex d
  - 4 Power supply
  - 5 Potential equalization line
  - 6 Potential equalization

- After aligning (rotating) the housing, retighten the fixing screw (see Operating Instructions).
- When mounting the device:
  - Exclude any mechanical damage or friction during the application.
  - Pay particular attention to flow conditions and tank fittings.
- Continuous service temperature of the connecting cable:  $-40$  to  $\geq +85$  °C; in accordance with the range of service temperature taking into account additional influences of the process conditions ( $T_{a,min}$ ), ( $T_{a,max} +20$  K).
- In potentially explosive atmospheres:
  - Do not open the electrical connection of the power supply circuit when energized.
  - Do not open the connection compartment cover.
- Only use certified cable entries suitable for the application.  
Observe national regulations or standards. Accordingly, the connection terminal does not include any ignition sources.
- When operating the transmitter housing at an ambient temperature under  $-20$  °C, use appropriate cables and cable entries permitted for this application.
- When connecting through a conduit entry approved for this purpose, mount the associated sealing unit directly at the housing.
- Seal unused entry glands with approved sealing plugs that correspond to the type of protection.  
The plastic transport sealing plug does not meet this requirement and must therefore be replaced during installation.
- Before operation:
  - Screw in the cover all the way.
  - Tighten the securing clamp on the cover.

**Intrinsic safety**

- The device can be connected to the Endress+Hauser FXA291 service tool: refer to the Operating Instructions.

**Potential equalization**

- Integrate the device into the local potential equalization.

**Safety instructions:  
Zone 0**

- In the event of potentially explosive vapor/air mixtures, only operate the device under atmospheric conditions.
  - Temperature:  $-20$  to  $+60$  °C
  - Pressure: 80 to 110 kPa (0.8 to 1.1 bar)
  - Air with normal oxygen content, usually 21 % (V/V)
 If no potentially explosive mixtures are present, or if additional protective measures have been taken, the device may also be operated under non-atmospheric conditions in accordance with the manufacturer's specifications.

**Temperature tables**

→  9

**Connection data**

Basic specification, Position 1, 2 (Approval) = MC

**Connection compartment Ex d**

The power consumption of I/O modules with passive PFS output can be limited for certain applications.

- Recommended: Power consumption = 1 W.  
This is obtained for a supply voltage at the terminals of 27 V DC.
- For higher supply voltages ( $U_{max}$ ): Insert a serial resistance ( $R_V$ ) in order to limit the power consumption → table below.

**Table for the PFS serial resistance ( $R_V$ ):**

Power consumption	1.0 W
Total power consumption	1.88 W
Internal resistance $R_i$	760 $\Omega$

$U_{\max}$ [V]	$R_V$ min
35	205 $\Omega$
34	177 $\Omega$
33	150 $\Omega$
32	122 $\Omega$
31	95 $\Omega$
30	67 $\Omega$
29	39 $\Omega$
28	12 $\Omega$
27	0 $\Omega$



Note!

For values associated with a higher or lower internal power consumption please contact Endress+Hauser.

Basic specification, Position 3 (Power Supply; Output) = A (TRC [03])

Terminal 1 (+), 2 (-)
Power supply: $U_N = 35$ V DC $U_m = 250$ V $I_{\max} = 22$ mA

Basic specification, Position 3 (Power Supply; Output) = B (TRC [03])

Terminal 1 (+), 2 (-)	Terminal 3 (+), 4 (-)
Power supply: $U_N = 35$ V DC $U_m = 250$ V $I_{\max} = 22$ mA	Switch output (PFS): $U_N = 35$ V DC $U_m = 250$ V

## Electronics compartment Ex ia

### Service interface (CDI)

Taking the following values into consideration, the device can be connected to the certified Endress+Hauser FXA291 service tool or a similar interface:

Service interface													
$U_i = 7.3$ V													
effective inner inductance $L_i =$ negligible													
effective inner capacitance $C_i =$ negligible													
$U_o = 7.3$ V													
$I_o = 100$ mA													
$P_o = 160$ mW													
$L_o$ (mH) =	5.00	2.00	1.00	0.50	0.20	0.10	0.05	0.02	0.01	0.005	0.002	0.001	
$C_o$ ( $\mu$ F) =	0.73	1.20	1.60	2.00	2.60	3.20	4.00	5.50	7.30	10.00	12.70	12.70	

# Temperature tables

## Table of Contents

General notes .....	10
Diagram .....	10
Antenna and electronics housing: Zone 1	
FMR50, Position 7, 8 (Antenna) = BM .....	11
FMR50, Position 7, 8 (Antenna) = BN, BR .....	11
FMR51 .....	12
FMR51, Position 9, 10 (Seal) = D3 .....	13
FMR51, Position 9, 10 (Seal) = D2 .....	14
FMR52, Position 7, 8 (Antenna) = BO .....	15
FMR52, Position 7, 8 (Antenna) = BP .....	16
FMR53, Position 11, 12, 13 (Process Connection) = RxF .....	16
FMR53 .....	17
FMR54 .....	18
FMR54, Position 9, 10 (Seal) = D1 .....	19
FMR54, Position 9, 10 (Seal) = D2 .....	20
FMR54, Position 7, 8 (Antenna) = Dx .....	21
Antenna: Zone 0, Electronics housing: Zone 1	
FMR5x .....	22

**General notes**



Unless otherwise indicated, the positions always refer to the basic specification.

Note!

Observe the permitted temperature range at the antenna.

\*1 = Functional

Max. permissible process temperature

**Selection table**

Position 1, 2 (Approval)		Position 5 (Housing)	
MC	Ex d [ia] IIC T6 Ga/Gb	B	GT18 dual compartment, 316L
		C	GT20 dual compartment, Alu coated

Position 3 (Power Supply; Output)		Transmission code of the terminal module	Channels
A	2-wire, 4-20 mA HART	TRC [03]	-
B	2-wire, 4-20 mA HART, switch output (PFS)	TRC [03]	1 or 2 channels used

**Diagram**

**Example diagrams to the temperature tables**

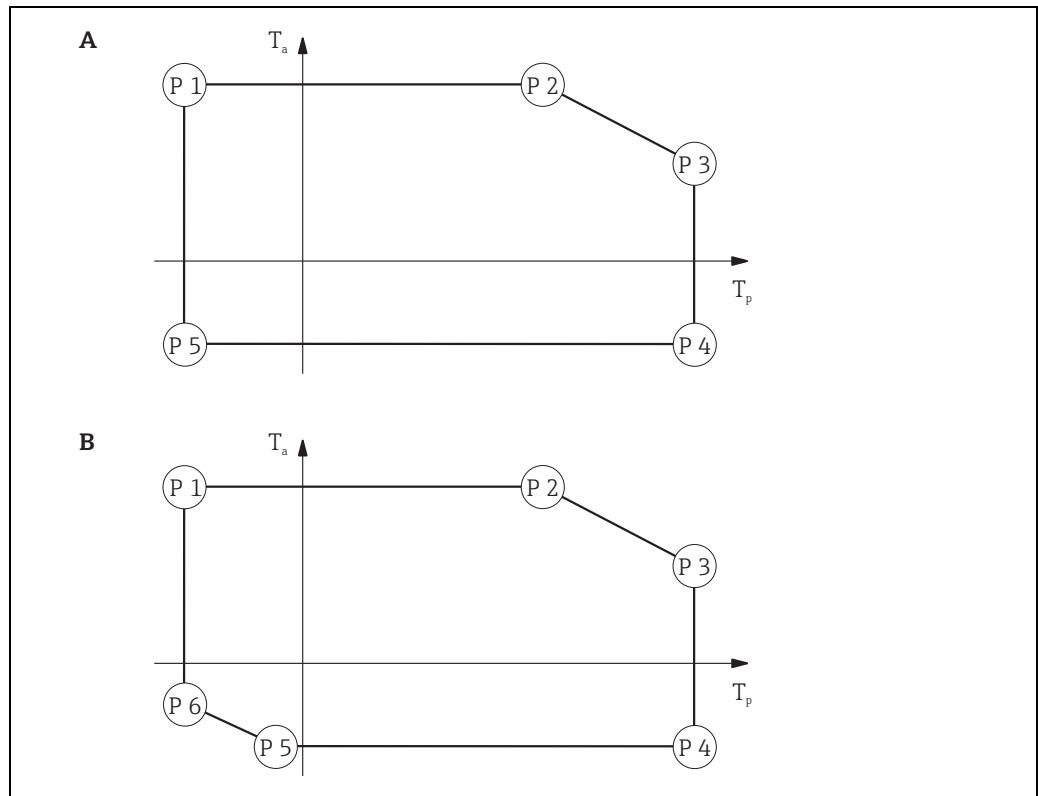

- A** Version 1
- B** Version 2

$T_a$  Ambient temperature  
 $T_p$  Process temperature

**Antenna and electronics housing: Zone 1**

**FMR50**, Position 7, 8 (Antenna) = BM

**Position 3 (Power Supply; Output) = A, B (TRC [03])**

Position 5 (Housing) = C													
Power Supply; Output	Temperature class	P 1		P 2		P 3		P 4		P 5		P 6	
		T <sub>p</sub>	T <sub>a</sub>	T <sub>p</sub>	T <sub>a</sub>	T <sub>p</sub>	T <sub>a</sub>	T <sub>p</sub>	T <sub>a</sub>	T <sub>p</sub>	T <sub>a</sub>	T <sub>p</sub>	T <sub>a</sub>
A; B: 1 channel used	T6 ( 85 °C)	-40 °C	60 °C	60 °C	60 °C	80 °C	58 °C	80 °C	-40 °C	-40 °C	-40 °C	-	-
B: 2 channels used	T6 ( 85 °C)	-40 °C	60 °C	60 °C	60 °C	80 °C	58 °C	80 °C	-40 °C	-40 °C	-40 °C	-	-

**FMR50**, Position 7, 8 (Antenna) = BN, BR

**Position 3 (Power Supply; Output) = A, B (TRC [03])**

Position 5 (Housing) = C													
Power Supply; Output	Temperature class	P 1		P 2		P 3		P 4		P 5		P 6	
		T <sub>p</sub>	T <sub>a</sub>	T <sub>p</sub>	T <sub>a</sub>	T <sub>p</sub>	T <sub>a</sub>	T <sub>p</sub>	T <sub>a</sub>	T <sub>p</sub>	T <sub>a</sub>	T <sub>p</sub>	T <sub>a</sub>
A; B: 1 channel used	T6 ( 85 °C)	-40 °C	60 °C	60 °C	60 °C	80 °C	58 °C	80 °C	-40 °C	-40 °C	-40 °C	-	-
B: 2 channels used	T6 ( 85 °C)	-40 °C	60 °C	60 °C	60 °C	80 °C	58 °C	80 °C	-40 °C	-40 °C	-40 °C	-	-

## Antenna and electronics housing: Zone 1

## FMR51

Position 3 (Power Supply; Output) = A, B (TRC [03])

Position 5 (Housing) = B													
Power Supply; Output	Temperature class	P 1		P 2		P 3		P 4		P 5		P 6	
		T <sub>p</sub>	T <sub>a</sub>	T <sub>p</sub>	T <sub>a</sub>	T <sub>p</sub>	T <sub>a</sub>	T <sub>p</sub>	T <sub>a</sub>	T <sub>p</sub>	T <sub>a</sub>	T <sub>p</sub>	T <sub>a</sub>
A; B: 1 channel used	T6 ( 85 °C)	-40 °C	60 °C	60 °C	60 °C	85 °C	54 °C	85 °C	-40 °C	-40 °C	-40 °C	-	-
	T5 (100 °C)	-40 °C	75 °C	75 °C	75 °C	100 °C	69 °C	100 °C	-40 °C	-40 °C	-40 °C	-	-
	T4 (135 °C)	-40 °C	80 °C	80 °C	80 °C	135 °C	68 °C	135 °C	-40 °C	-40 °C	-40 °C	-	-
	T3 (200 °C)	-40 °C	80 °C	80 °C	80 °C	150 °C	65 °C	150 °C	-40 °C	-40 °C	-40 °C	-	-
B: 2 channels used	T6 ( 85 °C)	-40 °C	60 °C	60 °C	60 °C	85 °C	54 °C	85 °C	-40 °C	-40 °C	-40 °C	-	-
	T5 (100 °C)	-40 °C	75 °C	75 °C	75 °C	100 °C	69 °C	100 °C	-40 °C	-40 °C	-40 °C	-	-
	T4 (135 °C)	-40 °C	75 °C	75 °C	75 °C	135 °C	62 °C	135 °C	-40 °C	-40 °C	-40 °C	-	-
	T3 (200 °C)	-40 °C	75 °C	75 °C	75 °C	150 °C	59 °C	150 °C	-40 °C	-40 °C	-40 °C	-	-

Position 5 (Housing) = C													
Power Supply; Output	Temperature class	P 1		P 2		P 3		P 4		P 5		P 6	
		T <sub>p</sub>	T <sub>a</sub>	T <sub>p</sub>	T <sub>a</sub>	T <sub>p</sub>	T <sub>a</sub>	T <sub>p</sub>	T <sub>a</sub>	T <sub>p</sub>	T <sub>a</sub>	T <sub>p</sub>	T <sub>a</sub>
A; B: 1 channel used	T6 ( 85 °C)	-40 °C	60 °C	60 °C	60 °C	85 °C	55 °C	85 °C	-40 °C	-40 °C	-40 °C	-	-
	T5 (100 °C)	-40 °C	75 °C	75 °C	75 °C	100 °C	70 °C	100 °C	-40 °C	-40 °C	-40 °C	-	-
	T4 (135 °C)	-40 °C	80 °C	80 °C	80 °C	135 °C	70 °C	135 °C	-40 °C	-40 °C	-40 °C	-	-
	T3 (200 °C)	-40 °C	80 °C	80 °C	80 °C	150 °C	68 °C	150 °C	-40 °C	-40 °C	-40 °C	-	-
B: 2 channels used	T6 ( 85 °C)	-40 °C	60 °C	60 °C	60 °C	85 °C	55 °C	85 °C	-40 °C	-40 °C	-40 °C	-	-
	T5 (100 °C)	-40 °C	75 °C	75 °C	75 °C	100 °C	70 °C	100 °C	-40 °C	-40 °C	-40 °C	-	-
	T4 (135 °C)	-40 °C	75 °C	75 °C	75 °C	135 °C	65 °C	135 °C	-40 °C	-40 °C	-40 °C	-	-
	T3 (200 °C)	-40 °C	75 °C	75 °C	75 °C	150 °C	62 °C	150 °C	-40 °C	-40 °C	-40 °C	-	-

**Antenna and electronics housing: Zone 1**

**FMR51**, Position 9, 10 (Seal) = D3

**Position 3 (Power Supply; Output) = A, B (TRC [03])**

Position 5 (Housing) = B													
Power Supply; Output	Temperature class	P 1		P 2		P 3		P 4		P 5		P 6	
		T <sub>p</sub>	T <sub>a</sub>	T <sub>p</sub>	T <sub>a</sub>	T <sub>p</sub>	T <sub>a</sub>	T <sub>p</sub>	T <sub>a</sub>	T <sub>p</sub>	T <sub>a</sub>	T <sub>p</sub>	T <sub>a</sub>
A; B: 1 channel used	T6 ( 85 °C)	-40 °C	60 °C	60 °C	60 °C	85 °C	57 °C	85 °C	-40 °C	-40 °C	-40 °C	-	-
	T5 (100 °C)	-40 °C	75 °C	75 °C	75 °C	100 °C	72 °C	100 °C	-40 °C	-40 °C	-40 °C	-	-
	T4 (135 °C)	-40 °C	80 °C	80 °C	80 °C	135 °C	74 °C	135 °C	-40 °C	-40 °C	-40 °C	-	-
	T3 (200 °C)	-40 °C	80 °C	80 °C	80 °C	200 °C	67 °C	200 °C	-40 °C	-40 °C	-40 °C	-	-
	T2 (300 °C)	-40 °C	80 °C	80 °C	80 °C	250 °C	62 °C	250 °C	-40 °C	-40 °C	-40 °C	-	-
B: 2 channels used	T6 ( 85 °C)	-40 °C	60 °C	60 °C	60 °C	85 °C	57 °C	85 °C	-40 °C	-40 °C	-40 °C	-	-
	T5 (100 °C)	-40 °C	75 °C	75 °C	75 °C	100 °C	72 °C	100 °C	-40 °C	-40 °C	-40 °C	-	-
	T4 (135 °C)	-40 °C	75 °C	75 °C	75 °C	135 °C	69 °C	135 °C	-40 °C	-40 °C	-40 °C	-	-
	T3 (200 °C)	-40 °C	75 °C	75 °C	75 °C	200 °C	62 °C	200 °C	-40 °C	-40 °C	-40 °C	-	-
	T2 (300 °C)	-40 °C	75 °C	75 °C	75 °C	250 °C	57 °C	250 °C	-40 °C	-40 °C	-40 °C	-	-

Position 5 (Housing) = C													
Power Supply; Output	Temperature class	P 1		P 2		P 3		P 4		P 5		P 6	
		T <sub>p</sub>	T <sub>a</sub>	T <sub>p</sub>	T <sub>a</sub>	T <sub>p</sub>	T <sub>a</sub>	T <sub>p</sub>	T <sub>a</sub>	T <sub>p</sub>	T <sub>a</sub>	T <sub>p</sub>	T <sub>a</sub>
A; B: 1 channel used	T6 ( 85 °C)	-40 °C	60 °C	60 °C	60 °C	85 °C	58 °C	85 °C	-40 °C	-40 °C	-40 °C	-	-
	T5 (100 °C)	-40 °C	75 °C	75 °C	75 °C	100 °C	73 °C	100 °C	-40 °C	-40 °C	-40 °C	-	-
	T4 (135 °C)	-40 °C	80 °C	80 °C	80 °C	135 °C	75 °C	135 °C	-40 °C	-40 °C	-40 °C	-	-
	T3 (200 °C)	-40 °C	80 °C	80 °C	80 °C	200 °C	70 °C	200 °C	-40 °C	-40 °C	-40 °C	-	-
	T2 (300 °C)	-40 °C	80 °C	80 °C	80 °C	250 °C	66 °C	250 °C	-40 °C	-40 °C	-40 °C	-	-
B: 2 channels used	T6 ( 85 °C)	-40 °C	60 °C	60 °C	60 °C	85 °C	58 °C	85 °C	-40 °C	-40 °C	-40 °C	-	-
	T5 (100 °C)	-40 °C	75 °C	75 °C	75 °C	100 °C	73 °C	100 °C	-40 °C	-40 °C	-40 °C	-	-
	T4 (135 °C)	-40 °C	75 °C	75 °C	75 °C	135 °C	70 °C	135 °C	-40 °C	-40 °C	-40 °C	-	-
	T3 (200 °C)	-40 °C	75 °C	75 °C	75 °C	200 °C	65 °C	200 °C	-40 °C	-40 °C	-40 °C	-	-
	T2 (300 °C)	-40 °C	75 °C	75 °C	75 °C	250 °C	60 °C	250 °C	-40 °C	-40 °C	-40 °C	-	-

## Antenna and electronics housing: Zone 1

FMR51, Position 9, 10 (Seal) = D2

Position 3 (Power Supply; Output) = A, B (TRC [03])

Position 5 (Housing) = B													
Power Supply; Output	Temperature class	P 1		P 2		P 3		P 4		P 5		P 6	
		T <sub>p</sub>	T <sub>a</sub>	T <sub>p</sub>	T <sub>a</sub>	T <sub>p</sub>	T <sub>a</sub>	T <sub>p</sub>	T <sub>a</sub>	T <sub>p</sub>	T <sub>a</sub>	T <sub>p</sub>	T <sub>a</sub>
A; B: 1 channel used	T6 ( 85 °C)	-196 °C	60 °C	60 °C	60 °C	85 °C	56 °C	85 °C	-40 °C	-40 °C	-40 °C	-196 °C	-15 °C
	T5 (100 °C)	-196 °C	75 °C	75 °C	75 °C	100 °C	71 °C	100 °C	-40 °C	-40 °C	-40 °C	-196 °C	-15 °C
	T4 (135 °C)	-196 °C	80 °C	80 °C	80 °C	135 °C	72 °C	135 °C	-40 °C	-40 °C	-40 °C	-196 °C	-15 °C
	T3 (200 °C)	-196 °C	80 °C	80 °C	80 °C	200 °C	64 °C	200 °C	-40 °C	-40 °C	-40 °C	-196 °C	-15 °C
	T2 (300 °C)	-196 °C	80 °C	80 °C	80 °C	300 °C	50 °C	300 °C	-40 °C	-40 °C	-40 °C	-196 °C	-15 °C
B: 2 channels used	T6 ( 85 °C)	-196 °C	60 °C	60 °C	60 °C	85 °C	56 °C	85 °C	-40 °C	-40 °C	-40 °C	-196 °C	-15 °C
	T5 (100 °C)	-196 °C	75 °C	75 °C	75 °C	100 °C	71 °C	100 °C	-40 °C	-40 °C	-40 °C	-196 °C	-15 °C
	T4 (135 °C)	-196 °C	75 °C	75 °C	75 °C	135 °C	67 °C	135 °C	-40 °C	-40 °C	-40 °C	-196 °C	-15 °C
	T3 (200 °C)	-196 °C	75 °C	75 °C	75 °C	200 °C	58 °C	200 °C	-40 °C	-40 °C	-40 °C	-196 °C	-15 °C
	T2 (300 °C)	-196 °C	75 °C	75 °C	75 °C	300 °C	44 °C	300 °C	-40 °C	-40 °C	-40 °C	-196 °C	-15 °C

Position 5 (Housing) = C													
Power Supply; Output	Temperature class	P 1		P 2		P 3		P 4		P 5		P 6	
		T <sub>p</sub>	T <sub>a</sub>	T <sub>p</sub>	T <sub>a</sub>	T <sub>p</sub>	T <sub>a</sub>	T <sub>p</sub>	T <sub>a</sub>	T <sub>p</sub>	T <sub>a</sub>	T <sub>p</sub>	T <sub>a</sub>
A; B: 1 channel used	T6 ( 85 °C)	-196 °C	60 °C	60 °C	60 °C	85 °C	57 °C	85 °C	-40 °C	-40 °C	-40 °C	-196 °C	-20 °C
	T5 (100 °C)	-196 °C	75 °C	75 °C	75 °C	100 °C	72 °C	100 °C	-40 °C	-40 °C	-40 °C	-196 °C	-20 °C
	T4 (135 °C)	-196 °C	80 °C	80 °C	80 °C	135 °C	74 °C	135 °C	-40 °C	-40 °C	-40 °C	-196 °C	-20 °C
	T3 (200 °C)	-196 °C	80 °C	80 °C	80 °C	200 °C	67 °C	200 °C	-40 °C	-40 °C	-40 °C	-196 °C	-20 °C
	T2 (300 °C)	-196 °C	80 °C	80 °C	80 °C	300 °C	56 °C	300 °C	-40 °C	-40 °C	-40 °C	-196 °C	-20 °C
	T1 (450 °C) * <sup>1</sup>	-196 °C	80 °C	80 °C	80 °C	450 °C	39 °C	450 °C	-40 °C	-40 °C	-40 °C	-196 °C	-20 °C
B: 2 channels used	T6 ( 85 °C)	-196 °C	60 °C	60 °C	60 °C	85 °C	57 °C	85 °C	-40 °C	-40 °C	-40 °C	-196 °C	-20 °C
	T5 (100 °C)	-196 °C	75 °C	75 °C	75 °C	100 °C	72 °C	100 °C	-40 °C	-40 °C	-40 °C	-196 °C	-20 °C
	T4 (135 °C)	-196 °C	75 °C	75 °C	75 °C	135 °C	68 °C	135 °C	-40 °C	-40 °C	-40 °C	-196 °C	-20 °C
	T3 (200 °C)	-196 °C	75 °C	75 °C	75 °C	200 °C	61 °C	200 °C	-40 °C	-40 °C	-40 °C	-196 °C	-20 °C
	T2 (300 °C)	-196 °C	75 °C	75 °C	75 °C	300 °C	51 °C	300 °C	-40 °C	-40 °C	-40 °C	-196 °C	-20 °C
	T1 (450 °C) * <sup>1</sup>	-196 °C	75 °C	75 °C	75 °C	450 °C	34 °C	450 °C	-40 °C	-40 °C	-40 °C	-196 °C	-20 °C

**Antenna and electronics housing: Zone 1**

**FMR52**, Position 7, 8 (Antenna) = BO

**Position 3 (Power Supply; Output) = A, B (TRC [03])**

Position 5 (Housing) = B													
Power Supply; Output	Temperature class	P 1		P 2		P 3		P 4		P 5		P 6	
		T <sub>p</sub>	T <sub>a</sub>	T <sub>p</sub>	T <sub>a</sub>	T <sub>p</sub>	T <sub>a</sub>	T <sub>p</sub>	T <sub>a</sub>	T <sub>p</sub>	T <sub>a</sub>	T <sub>p</sub>	T <sub>a</sub>
A; B: 1 channel used	T6 ( 85 °C)	-40 °C	60 °C	60 °C	60 °C	85 °C	55 °C	85 °C	-40 °C	-40 °C	-40 °C	-	-
	T5 (100 °C)	-40 °C	75 °C	75 °C	75 °C	100 °C	70 °C	100 °C	-40 °C	-40 °C	-40 °C	-	-
	T4 (135 °C)	-40 °C	80 °C	80 °C	80 °C	135 °C	71 °C	135 °C	-40 °C	-40 °C	-40 °C	-	-
	T3 (200 °C)	-40 °C	80 °C	80 °C	80 °C	200 °C	59 °C	200 °C	-40 °C	-40 °C	-40 °C	-	-
B: 2 channels used	T6 ( 85 °C)	-40 °C	60 °C	60 °C	60 °C	85 °C	55 °C	85 °C	-40 °C	-40 °C	-40 °C	-	-
	T5 (100 °C)	-40 °C	75 °C	75 °C	75 °C	100 °C	70 °C	100 °C	-40 °C	-40 °C	-40 °C	-	-
	T4 (135 °C)	-40 °C	75 °C	75 °C	75 °C	135 °C	65 °C	135 °C	-40 °C	-40 °C	-40 °C	-	-
	T3 (200 °C)	-40 °C	75 °C	75 °C	75 °C	200 °C	53 °C	200 °C	-40 °C	-40 °C	-40 °C	-	-

Position 5 (Housing) = C													
Power Supply; Output	Temperature class	P 1		P 2		P 3		P 4		P 5		P 6	
		T <sub>p</sub>	T <sub>a</sub>	T <sub>p</sub>	T <sub>a</sub>	T <sub>p</sub>	T <sub>a</sub>	T <sub>p</sub>	T <sub>a</sub>	T <sub>p</sub>	T <sub>a</sub>	T <sub>p</sub>	T <sub>a</sub>
A; B: 1 channel used	T6 ( 85 °C)	-40 °C	60 °C	60 °C	60 °C	85 °C	56 °C	85 °C	-40 °C	-40 °C	-40 °C	-	-
	T5 (100 °C)	-40 °C	75 °C	75 °C	75 °C	100 °C	71 °C	100 °C	-40 °C	-40 °C	-40 °C	-	-
	T4 (135 °C)	-40 °C	80 °C	80 °C	80 °C	135 °C	72 °C	135 °C	-40 °C	-40 °C	-40 °C	-	-
	T3 (200 °C)	-40 °C	80 °C	80 °C	80 °C	200 °C	63 °C	200 °C	-40 °C	-40 °C	-40 °C	-	-
B: 2 channels used	T6 ( 85 °C)	-40 °C	60 °C	60 °C	60 °C	85 °C	56 °C	85 °C	-40 °C	-40 °C	-40 °C	-	-
	T5 (100 °C)	-40 °C	75 °C	75 °C	75 °C	100 °C	71 °C	100 °C	-40 °C	-40 °C	-40 °C	-	-
	T4 (135 °C)	-40 °C	75 °C	75 °C	75 °C	135 °C	67 °C	135 °C	-40 °C	-40 °C	-40 °C	-	-
	T3 (200 °C)	-40 °C	75 °C	75 °C	75 °C	200 °C	58 °C	200 °C	-40 °C	-40 °C	-40 °C	-	-

## Antenna and electronics housing: Zone 1

FMR52, Position 7, 8 (Antenna) = BP

Position 3 (Power Supply; Output) = A, B (TRC [03])

Position 5 (Housing) = B													
Power Supply; Output	Temperature class	P 1		P 2		P 3		P 4		P 5		P 6	
		T <sub>p</sub>	T <sub>a</sub>	T <sub>p</sub>	T <sub>a</sub>	T <sub>p</sub>	T <sub>a</sub>	T <sub>p</sub>	T <sub>a</sub>	T <sub>p</sub>	T <sub>a</sub>	T <sub>p</sub>	T <sub>a</sub>
A; B: 1 channel used	T6 ( 85 °C)	-40 °C	60 °C	60 °C	60 °C	85 °C	54 °C	85 °C	-40 °C	-40 °C	-40 °C	-	-
	T5 (100 °C)	-40 °C	75 °C	75 °C	75 °C	100 °C	69 °C	100 °C	-40 °C	-40 °C	-40 °C	-	-
	T4 (135 °C)	-40 °C	80 °C	80 °C	80 °C	135 °C	69 °C	135 °C	-40 °C	-40 °C	-40 °C	-	-
	T3 (200 °C)	-40 °C	80 °C	80 °C	80 °C	200 °C	55 °C	200 °C	-40 °C	-40 °C	-40 °C	-	-
B: 2 channels used	T6 ( 85 °C)	-40 °C	60 °C	60 °C	60 °C	85 °C	54 °C	85 °C	-40 °C	-40 °C	-40 °C	-	-
	T5 (100 °C)	-40 °C	75 °C	75 °C	75 °C	100 °C	69 °C	100 °C	-40 °C	-40 °C	-40 °C	-	-
	T4 (135 °C)	-40 °C	75 °C	75 °C	75 °C	135 °C	63 °C	135 °C	-40 °C	-40 °C	-40 °C	-	-
	T3 (200 °C)	-40 °C	75 °C	75 °C	75 °C	200 °C	49 °C	200 °C	-40 °C	-40 °C	-40 °C	-	-

Position 5 (Housing) = C													
Power Supply; Output	Temperature class	P 1		P 2		P 3		P 4		P 5		P 6	
		T <sub>p</sub>	T <sub>a</sub>	T <sub>p</sub>	T <sub>a</sub>	T <sub>p</sub>	T <sub>a</sub>	T <sub>p</sub>	T <sub>a</sub>	T <sub>p</sub>	T <sub>a</sub>	T <sub>p</sub>	T <sub>a</sub>
A; B: 1 channel used	T6 ( 85 °C)	-40 °C	60 °C	60 °C	60 °C	85 °C	55 °C	85 °C	-40 °C	-40 °C	-40 °C	-	-
	T5 (100 °C)	-40 °C	75 °C	75 °C	75 °C	100 °C	70 °C	100 °C	-40 °C	-40 °C	-40 °C	-	-
	T4 (135 °C)	-40 °C	80 °C	80 °C	80 °C	135 °C	71 °C	135 °C	-40 °C	-40 °C	-40 °C	-	-
	T3 (200 °C)	-40 °C	80 °C	80 °C	80 °C	200 °C	60 °C	200 °C	-40 °C	-40 °C	-40 °C	-	-
B: 2 channels used	T6 ( 85 °C)	-40 °C	60 °C	60 °C	60 °C	85 °C	55 °C	85 °C	-40 °C	-40 °C	-40 °C	-	-
	T5 (100 °C)	-40 °C	75 °C	75 °C	75 °C	100 °C	70 °C	100 °C	-40 °C	-40 °C	-40 °C	-	-
	T4 (135 °C)	-40 °C	75 °C	75 °C	75 °C	135 °C	65 °C	135 °C	-40 °C	-40 °C	-40 °C	-	-
	T3 (200 °C)	-40 °C	75 °C	75 °C	75 °C	200 °C	54 °C	200 °C	-40 °C	-40 °C	-40 °C	-	-

FMR53, Position 11, 12, 13 (Process Connection) = RxF

Position 3 (Power Supply; Output) = A, B (TRC [03])

Position 5 (Housing) = B													
Power Supply; Output	Temperature class	P 1		P 2		P 3		P 4		P 5		P 6	
		T <sub>p</sub>	T <sub>a</sub>	T <sub>p</sub>	T <sub>a</sub>	T <sub>p</sub>	T <sub>a</sub>	T <sub>p</sub>	T <sub>a</sub>	T <sub>p</sub>	T <sub>a</sub>	T <sub>p</sub>	T <sub>a</sub>
A; B: 1 channel used	T6 ( 85 °C)	-40 °C	60 °C	60 °C	60 °C	80 °C	58 °C	80 °C	-40 °C	-40 °C	-40 °C	-	-
B: 2 channels used	T6 ( 85 °C)	-40 °C	60 °C	60 °C	60 °C	80 °C	58 °C	80 °C	-40 °C	-40 °C	-40 °C	-	-

Position 5 (Housing) = C													
Power Supply; Output	Temperature class	P 1		P 2		P 3		P 4		P 5		P 6	
		T <sub>p</sub>	T <sub>a</sub>	T <sub>p</sub>	T <sub>a</sub>	T <sub>p</sub>	T <sub>a</sub>	T <sub>p</sub>	T <sub>a</sub>	T <sub>p</sub>	T <sub>a</sub>	T <sub>p</sub>	T <sub>a</sub>
A; B: 1 channel used	T6 ( 85 °C)	-40 °C	60 °C	60 °C	60 °C	80 °C	58 °C	80 °C	-40 °C	-40 °C	-40 °C	-	-
B: 2 channels used	T6 ( 85 °C)	-40 °C	60 °C	60 °C	60 °C	80 °C	58 °C	80 °C	-40 °C	-40 °C	-40 °C	-	-

**Antenna and electronics housing: Zone 1**

**FMR53**

**Position 3 (Power Supply; Output) = A, B (TRC [03])**

Position 5 (Housing) = B													
Power Supply; Output	Temperature class	P 1		P 2		P 3		P 4		P 5		P 6	
		T <sub>p</sub>	T <sub>a</sub>	T <sub>p</sub>	T <sub>a</sub>	T <sub>p</sub>	T <sub>a</sub>	T <sub>p</sub>	T <sub>a</sub>	T <sub>p</sub>	T <sub>a</sub>	T <sub>p</sub>	T <sub>a</sub>
A; B: 1 channel used	T6 ( 85 °C)	-40 °C	60 °C	60 °C	60 °C	85 °C	53 °C	85 °C	-40 °C	-40 °C	-40 °C	-	-
	T5 (100 °C)	-40 °C	75 °C	75 °C	75 °C	100 °C	68 °C	100 °C	-40 °C	-40 °C	-40 °C	-	-
	T4 (135 °C)	-40 °C	80 °C	80 °C	80 °C	135 °C	67 °C	135 °C	-40 °C	-40 °C	-40 °C	-	-
	T3 (200 °C)	-40 °C	80 °C	80 °C	80 °C	150 °C	64 °C	150 °C	-40 °C	-40 °C	-40 °C	-	-
B: 2 channels used	T6 ( 85 °C)	-40 °C	60 °C	60 °C	60 °C	85 °C	53 °C	85 °C	-40 °C	-40 °C	-40 °C	-	-
	T5 (100 °C)	-40 °C	75 °C	75 °C	75 °C	100 °C	68 °C	100 °C	-40 °C	-40 °C	-40 °C	-	-
	T4 (135 °C)	-40 °C	75 °C	75 °C	75 °C	135 °C	61 °C	135 °C	-40 °C	-40 °C	-40 °C	-	-
	T3 (200 °C)	-40 °C	75 °C	75 °C	75 °C	150 °C	58 °C	150 °C	-40 °C	-40 °C	-40 °C	-	-

Position 5 (Housing) = C													
Power Supply; Output	Temperature class	P 1		P 2		P 3		P 4		P 5		P 6	
		T <sub>p</sub>	T <sub>a</sub>	T <sub>p</sub>	T <sub>a</sub>	T <sub>p</sub>	T <sub>a</sub>	T <sub>p</sub>	T <sub>a</sub>	T <sub>p</sub>	T <sub>a</sub>	T <sub>p</sub>	T <sub>a</sub>
A; B: 1 channel used	T6 ( 85 °C)	-40 °C	60 °C	60 °C	60 °C	85 °C	54 °C	85 °C	-40 °C	-40 °C	-40 °C	-	-
	T5 (100 °C)	-40 °C	75 °C	75 °C	75 °C	100 °C	69 °C	100 °C	-40 °C	-40 °C	-40 °C	-	-
	T4 (135 °C)	-40 °C	80 °C	80 °C	80 °C	135 °C	70 °C	135 °C	-40 °C	-40 °C	-40 °C	-	-
	T3 (200 °C)	-40 °C	80 °C	80 °C	80 °C	150 °C	67 °C	150 °C	-40 °C	-40 °C	-40 °C	-	-
B: 2 channels used	T6 ( 85 °C)	-40 °C	60 °C	60 °C	60 °C	85 °C	54 °C	85 °C	-40 °C	-40 °C	-40 °C	-	-
	T5 (100 °C)	-40 °C	75 °C	75 °C	75 °C	100 °C	69 °C	100 °C	-40 °C	-40 °C	-40 °C	-	-
	T4 (135 °C)	-40 °C	75 °C	75 °C	75 °C	135 °C	64 °C	135 °C	-40 °C	-40 °C	-40 °C	-	-
	T3 (200 °C)	-40 °C	75 °C	75 °C	75 °C	150 °C	61 °C	150 °C	-40 °C	-40 °C	-40 °C	-	-

## Antenna and electronics housing: Zone 1

## FMR54

## Position 3 (Power Supply; Output) = A, B (TRC [03])

Position 5 (Housing) = B													
Power Supply; Output	Temperature class	P 1		P 2		P 3		P 4		P 5		P 6	
		T <sub>p</sub>	T <sub>a</sub>	T <sub>p</sub>	T <sub>a</sub>	T <sub>p</sub>	T <sub>a</sub>	T <sub>p</sub>	T <sub>a</sub>	T <sub>p</sub>	T <sub>a</sub>	T <sub>p</sub>	T <sub>a</sub>
A; B: 1 channel used	T6 ( 85 °C)	-40 °C	60 °C	60 °C	60 °C	85 °C	53 °C	85 °C	-40 °C	-40 °C	-40 °C	-	-
	T5 (100 °C)	-40 °C	75 °C	75 °C	75 °C	100 °C	68 °C	100 °C	-40 °C	-40 °C	-40 °C	-	-
	T4 (135 °C)	-40 °C	80 °C	80 °C	80 °C	135 °C	67 °C	135 °C	-40 °C	-40 °C	-40 °C	-	-
	T3 (200 °C)	-40 °C	80 °C	80 °C	80 °C	200 °C	51 °C	200 °C	-40 °C	-40 °C	-40 °C	-	-
B: 2 channels used	T6 ( 85 °C)	-40 °C	60 °C	60 °C	60 °C	85 °C	53 °C	85 °C	-40 °C	-40 °C	-40 °C	-	-
	T5 (100 °C)	-40 °C	75 °C	75 °C	75 °C	100 °C	68 °C	100 °C	-40 °C	-40 °C	-40 °C	-	-
	T4 (135 °C)	-40 °C	75 °C	75 °C	75 °C	135 °C	60 °C	135 °C	-40 °C	-40 °C	-40 °C	-	-
	T3 (200 °C)	-40 °C	75 °C	75 °C	75 °C	200 °C	45 °C	200 °C	-40 °C	-40 °C	-40 °C	-	-

Position 5 (Housing) = C													
Power Supply; Output	Temperature class	P 1		P 2		P 3		P 4		P 5		P 6	
		T <sub>p</sub>	T <sub>a</sub>	T <sub>p</sub>	T <sub>a</sub>	T <sub>p</sub>	T <sub>a</sub>	T <sub>p</sub>	T <sub>a</sub>	T <sub>p</sub>	T <sub>a</sub>	T <sub>p</sub>	T <sub>a</sub>
A; B: 1 channel used	T6 ( 85 °C)	-40 °C	60 °C	60 °C	60 °C	85 °C	54 °C	85 °C	-40 °C	-40 °C	-40 °C	-	-
	T5 (100 °C)	-40 °C	75 °C	75 °C	75 °C	100 °C	69 °C	100 °C	-40 °C	-40 °C	-40 °C	-	-
	T4 (135 °C)	-40 °C	80 °C	80 °C	80 °C	135 °C	69 °C	135 °C	-40 °C	-40 °C	-40 °C	-	-
	T3 (200 °C)	-40 °C	80 °C	80 °C	80 °C	200 °C	56 °C	200 °C	-40 °C	-40 °C	-40 °C	-	-
B: 2 channels used	T6 ( 85 °C)	-40 °C	60 °C	60 °C	60 °C	85 °C	54 °C	85 °C	-40 °C	-40 °C	-40 °C	-	-
	T5 (100 °C)	-40 °C	75 °C	75 °C	75 °C	100 °C	69 °C	100 °C	-40 °C	-40 °C	-40 °C	-	-
	T4 (135 °C)	-40 °C	75 °C	75 °C	75 °C	135 °C	63 °C	135 °C	-40 °C	-40 °C	-40 °C	-	-
	T3 (200 °C)	-40 °C	75 °C	75 °C	75 °C	200 °C	50 °C	200 °C	-40 °C	-40 °C	-40 °C	-	-

**Antenna and electronics housing: Zone 1**

**FMR54**, Position 9, 10 (Seal) = D1

**Position 3 (Power Supply; Output) = A, B (TRC [03])**

Position 5 (Housing) = B													
Power Supply; Output	Temperature class	P 1		P 2		P 3		P 4		P 5		P 6	
		T <sub>p</sub>	T <sub>a</sub>	T <sub>p</sub>	T <sub>a</sub>	T <sub>p</sub>	T <sub>a</sub>	T <sub>p</sub>	T <sub>a</sub>	T <sub>p</sub>	T <sub>a</sub>	T <sub>p</sub>	T <sub>a</sub>
A; B: 1 channel used	T6 ( 85 °C)	-196 °C	60 °C	60 °C	60 °C	85 °C	55 °C	85 °C	-40 °C	-40 °C	-40 °C	-196 °C	-9 °C
	T5 (100 °C)	-196 °C	75 °C	75 °C	75 °C	100 °C	70 °C	100 °C	-40 °C	-40 °C	-40 °C	-196 °C	-9 °C
	T4 (135 °C)	-196 °C	80 °C	80 °C	80 °C	135 °C	71 °C	135 °C	-40 °C	-40 °C	-40 °C	-196 °C	-9 °C
	T3 (200 °C)	-196 °C	80 °C	80 °C	80 °C	200 °C	60 °C	200 °C	-40 °C	-40 °C	-40 °C	-196 °C	-9 °C
	T2 (300 °C)	-196 °C	80 °C	80 °C	80 °C	280 °C	46 °C	280 °C	-40 °C	-40 °C	-40 °C	-196 °C	-9 °C
B: 2 channels used	T6 ( 85 °C)	-196 °C	60 °C	60 °C	60 °C	85 °C	55 °C	85 °C	-40 °C	-40 °C	-40 °C	-196 °C	-9 °C
	T5 (100 °C)	-196 °C	75 °C	75 °C	75 °C	100 °C	70 °C	100 °C	-40 °C	-40 °C	-40 °C	-196 °C	-9 °C
	T4 (135 °C)	-196 °C	75 °C	75 °C	75 °C	135 °C	65 °C	135 °C	-40 °C	-40 °C	-40 °C	-196 °C	-9 °C
	T3 (200 °C)	-196 °C	75 °C	75 °C	75 °C	200 °C	54 °C	200 °C	-40 °C	-40 °C	-40 °C	-196 °C	-9 °C
	T2 (300 °C)	-196 °C	75 °C	75 °C	75 °C	280 °C	40 °C	280 °C	-40 °C	-40 °C	-40 °C	-196 °C	-9 °C

Position 5 (Housing) = C													
Power Supply; Output	Temperature class	P 1		P 2		P 3		P 4		P 5		P 6	
		T <sub>p</sub>	T <sub>a</sub>	T <sub>p</sub>	T <sub>a</sub>	T <sub>p</sub>	T <sub>a</sub>	T <sub>p</sub>	T <sub>a</sub>	T <sub>p</sub>	T <sub>a</sub>	T <sub>p</sub>	T <sub>a</sub>
A; B: 1 channel used	T6 ( 85 °C)	-196 °C	60 °C	60 °C	60 °C	85 °C	56 °C	85 °C	-40 °C	-40 °C	-40 °C	-196 °C	-15 °C
	T5 (100 °C)	-196 °C	75 °C	75 °C	75 °C	100 °C	71 °C	100 °C	-40 °C	-40 °C	-40 °C	-196 °C	-15 °C
	T4 (135 °C)	-196 °C	80 °C	80 °C	80 °C	135 °C	72 °C	135 °C	-40 °C	-40 °C	-40 °C	-196 °C	-15 °C
	T3 (200 °C)	-196 °C	80 °C	80 °C	80 °C	200 °C	64 °C	200 °C	-40 °C	-40 °C	-40 °C	-196 °C	-15 °C
	T2 (300 °C)	-196 °C	80 °C	80 °C	80 °C	280 °C	53 °C	280 °C	-40 °C	-40 °C	-40 °C	-196 °C	-15 °C
B: 2 channels used	T6 ( 85 °C)	-196 °C	60 °C	60 °C	60 °C	85 °C	56 °C	85 °C	-40 °C	-40 °C	-40 °C	-196 °C	-15 °C
	T5 (100 °C)	-196 °C	75 °C	75 °C	75 °C	100 °C	71 °C	100 °C	-40 °C	-40 °C	-40 °C	-196 °C	-15 °C
	T4 (135 °C)	-196 °C	75 °C	75 °C	75 °C	135 °C	67 °C	135 °C	-40 °C	-40 °C	-40 °C	-196 °C	-15 °C
	T3 (200 °C)	-196 °C	75 °C	75 °C	75 °C	200 °C	58 °C	200 °C	-40 °C	-40 °C	-40 °C	-196 °C	-15 °C
	T2 (300 °C)	-196 °C	75 °C	75 °C	75 °C	280 °C	47 °C	280 °C	-40 °C	-40 °C	-40 °C	-196 °C	-15 °C

## Antenna and electronics housing: Zone 1

FMR54, Position 9, 10 (Seal) = D2

Position 3 (Power Supply; Output) = A, B (TRC [03])

Position 5 (Housing) = B													
Power Supply; Output	Temperature class	P 1		P 2		P 3		P 4		P 5		P 6	
		T <sub>p</sub>	T <sub>a</sub>	T <sub>p</sub>	T <sub>a</sub>	T <sub>p</sub>	T <sub>a</sub>	T <sub>p</sub>	T <sub>a</sub>	T <sub>p</sub>	T <sub>a</sub>	T <sub>p</sub>	T <sub>a</sub>
A; B: 1 channel used	T6 ( 85 °C)	-196 °C	60 °C	60 °C	60 °C	85 °C	56 °C	85 °C	-40 °C	-40 °C	-40 °C	-196 °C	-13 °C
	T5 (100 °C)	-196 °C	75 °C	75 °C	75 °C	100 °C	71 °C	100 °C	-40 °C	-40 °C	-40 °C	-196 °C	-13 °C
	T4 (135 °C)	-196 °C	80 °C	80 °C	80 °C	135 °C	72 °C	135 °C	-40 °C	-40 °C	-40 °C	-196 °C	-13 °C
	T3 (200 °C)	-196 °C	80 °C	80 °C	80 °C	200 °C	62 °C	200 °C	-40 °C	-40 °C	-40 °C	-196 °C	-13 °C
	T2 (300 °C)	-196 °C	80 °C	80 °C	80 °C	300 °C	48 °C	300 °C	-40 °C	-40 °C	-40 °C	-196 °C	-13 °C
	T1 (450 °C) *1	-196 °C	80 °C	80 °C	80 °C	400 °C	31 °C	400 °C	-40 °C	-40 °C	-40 °C	-196 °C	-13 °C
B: 2 channels used	T6 ( 85 °C)	-196 °C	60 °C	60 °C	60 °C	85 °C	56 °C	85 °C	-40 °C	-40 °C	-40 °C	-196 °C	-13 °C
	T5 (100 °C)	-196 °C	75 °C	75 °C	75 °C	100 °C	71 °C	100 °C	-40 °C	-40 °C	-40 °C	-196 °C	-13 °C
	T4 (135 °C)	-196 °C	75 °C	75 °C	75 °C	135 °C	66 °C	135 °C	-40 °C	-40 °C	-40 °C	-196 °C	-13 °C
	T3 (200 °C)	-196 °C	75 °C	75 °C	75 °C	200 °C	57 °C	200 °C	-40 °C	-40 °C	-40 °C	-196 °C	-13 °C
	T2 (300 °C)	-196 °C	75 °C	75 °C	75 °C	300 °C	42 °C	300 °C	-40 °C	-40 °C	-40 °C	-196 °C	-13 °C

Position 5 (Housing) = C													
Power Supply; Output	Temperature class	P 1		P 2		P 3		P 4		P 5		P 6	
		T <sub>p</sub>	T <sub>a</sub>	T <sub>p</sub>	T <sub>a</sub>	T <sub>p</sub>	T <sub>a</sub>	T <sub>p</sub>	T <sub>a</sub>	T <sub>p</sub>	T <sub>a</sub>	T <sub>p</sub>	T <sub>a</sub>
A; B: 1 channel used	T6 ( 85 °C)	-196 °C	60 °C	60 °C	60 °C	85 °C	57 °C	85 °C	-40 °C	-40 °C	-40 °C	-196 °C	-19 °C
	T5 (100 °C)	-196 °C	75 °C	75 °C	75 °C	100 °C	72 °C	100 °C	-40 °C	-40 °C	-40 °C	-196 °C	-19 °C
	T4 (135 °C)	-196 °C	80 °C	80 °C	80 °C	135 °C	74 °C	135 °C	-40 °C	-40 °C	-40 °C	-196 °C	-19 °C
	T3 (200 °C)	-196 °C	80 °C	80 °C	80 °C	200 °C	66 °C	200 °C	-40 °C	-40 °C	-40 °C	-196 °C	-19 °C
	T2 (300 °C)	-196 °C	80 °C	80 °C	80 °C	300 °C	54 °C	300 °C	-40 °C	-40 °C	-40 °C	-196 °C	-19 °C
	T1 (450 °C) *1	-196 °C	80 °C	80 °C	80 °C	400 °C	42 °C	400 °C	-40 °C	-40 °C	-40 °C	-196 °C	-19 °C
B: 2 channels used	T6 ( 85 °C)	-196 °C	60 °C	60 °C	60 °C	85 °C	57 °C	85 °C	-40 °C	-40 °C	-40 °C	-196 °C	-19 °C
	T5 (100 °C)	-196 °C	75 °C	75 °C	75 °C	100 °C	72 °C	100 °C	-40 °C	-40 °C	-40 °C	-196 °C	-19 °C
	T4 (135 °C)	-196 °C	75 °C	75 °C	75 °C	135 °C	68 °C	135 °C	-40 °C	-40 °C	-40 °C	-196 °C	-19 °C
	T3 (200 °C)	-196 °C	75 °C	75 °C	75 °C	200 °C	60 °C	200 °C	-40 °C	-40 °C	-40 °C	-196 °C	-19 °C
	T2 (300 °C)	-196 °C	75 °C	75 °C	75 °C	300 °C	49 °C	300 °C	-40 °C	-40 °C	-40 °C	-196 °C	-19 °C
	T1 (450 °C) *1	-196 °C	75 °C	75 °C	75 °C	400 °C	37 °C	400 °C	-40 °C	-40 °C	-40 °C	-196 °C	-19 °C

**Antenna and electronics housing: Zone 1**

**FMR54**, Position 7, 8 (Antenna) = Dx

**Position 3 (Power Supply; Output) = A, B (TRC [03])**

Position 5 (Housing) = B													
Power Supply; Output	Temperature class	P 1		P 2		P 3		P 4		P 5		P 6	
		T <sub>p</sub>	T <sub>a</sub>	T <sub>p</sub>	T <sub>a</sub>	T <sub>p</sub>	T <sub>a</sub>	T <sub>p</sub>	T <sub>a</sub>	T <sub>p</sub>	T <sub>a</sub>	T <sub>p</sub>	T <sub>a</sub>
A; B: 1 channel used	T6 ( 85 °C)	-40 °C	60 °C	60 °C	60 °C	85 °C	55 °C	85 °C	-40 °C	-40 °C	-40 °C	-	-
	T5 (100 °C)	-40 °C	75 °C	75 °C	75 °C	100 °C	70 °C	100 °C	-40 °C	-40 °C	-40 °C	-	-
	T4 (135 °C)	-40 °C	80 °C	80 °C	80 °C	135 °C	70 °C	135 °C	-40 °C	-40 °C	-40 °C	-	-
	T3 (200 °C)	-40 °C	80 °C	80 °C	80 °C	150 °C	68 °C	150 °C	-40 °C	-40 °C	-40 °C	-	-
B: 2 channels used	T6 ( 85 °C)	-40 °C	60 °C	60 °C	60 °C	85 °C	55 °C	85 °C	-40 °C	-40 °C	-40 °C	-	-
	T5 (100 °C)	-40 °C	75 °C	75 °C	75 °C	100 °C	70 °C	100 °C	-40 °C	-40 °C	-40 °C	-	-
	T4 (135 °C)	-40 °C	75 °C	75 °C	75 °C	135 °C	64 °C	135 °C	-40 °C	-40 °C	-40 °C	-	-
	T3 (200 °C)	-40 °C	75 °C	75 °C	75 °C	150 °C	62 °C	150 °C	-40 °C	-40 °C	-40 °C	-	-

Position 5 (Housing) = C													
Power Supply; Output	Temperature class	P 1		P 2		P 3		P 4		P 5		P 6	
		T <sub>p</sub>	T <sub>a</sub>	T <sub>p</sub>	T <sub>a</sub>	T <sub>p</sub>	T <sub>a</sub>	T <sub>p</sub>	T <sub>a</sub>	T <sub>p</sub>	T <sub>a</sub>	T <sub>p</sub>	T <sub>a</sub>
A; B: 1 channel used	T6 ( 85 °C)	-40 °C	60 °C	60 °C	60 °C	85 °C	56 °C	85 °C	-40 °C	-40 °C	-40 °C	-	-
	T5 (100 °C)	-40 °C	75 °C	75 °C	75 °C	100 °C	71 °C	100 °C	-40 °C	-40 °C	-40 °C	-	-
	T4 (135 °C)	-40 °C	80 °C	80 °C	80 °C	135 °C	72 °C	135 °C	-40 °C	-40 °C	-40 °C	-	-
	T3 (200 °C)	-40 °C	80 °C	80 °C	80 °C	150 °C	70 °C	150 °C	-40 °C	-40 °C	-40 °C	-	-
B: 2 channels used	T6 ( 85 °C)	-40 °C	60 °C	60 °C	60 °C	85 °C	56 °C	85 °C	-40 °C	-40 °C	-40 °C	-	-
	T5 (100 °C)	-40 °C	75 °C	75 °C	75 °C	100 °C	71 °C	100 °C	-40 °C	-40 °C	-40 °C	-	-
	T4 (135 °C)	-40 °C	75 °C	75 °C	75 °C	135 °C	66 °C	135 °C	-40 °C	-40 °C	-40 °C	-	-
	T3 (200 °C)	-40 °C	75 °C	75 °C	75 °C	150 °C	64 °C	150 °C	-40 °C	-40 °C	-40 °C	-	-

## Antenna: Zone 0, Electronics housing: Zone 1

## FMR5x

## Position 3 (Power Supply; Output) = A, B (TRC [03])

Position 5 (Housing) = B, C													
Power Supply; Output	Temperature class	P 1		P 2		P 3		P 4		P 5		P 6	
		T <sub>p</sub>	T <sub>a</sub>	T <sub>p</sub>	T <sub>a</sub>	T <sub>p</sub>	T <sub>a</sub>	T <sub>p</sub>	T <sub>a</sub>	T <sub>p</sub>	T <sub>a</sub>	T <sub>p</sub>	T <sub>a</sub>
A; B: 1 channel used	T6 ( 85 °C)	-20 °C	60 °C	60 °C	60 °C	60 °C	60 °C	60 °C	-40 °C	-20 °C	-40 °C	-	-
	T5 (100 °C)	-20 °C	75 °C	60 °C	75 °C	60 °C	75 °C	60 °C	-40 °C	-20 °C	-40 °C	-	-
	T4 (135 °C)	-20 °C	80 °C	60 °C	80 °C	60 °C	80 °C	60 °C	-40 °C	-20 °C	-40 °C	-	-
B: 2 channels used	T6 ( 85 °C)	-20 °C	60 °C	60 °C	60 °C	60 °C	60 °C	60 °C	-40 °C	-20 °C	-40 °C	-	-
	T5 (100 °C)	-20 °C	75 °C	60 °C	75 °C	60 °C	75 °C	60 °C	-40 °C	-20 °C	-40 °C	-	-





71252404

[www.addresses.endress.com](http://www.addresses.endress.com)

---