

Technical Information

HAW566

Surge Protective Device



DIN rail surge protective device for installation in the control cabinet for power supply and communication signals with SIL and optional Ex approval

Application

Surge protective devices are used to weaken residual currents from upstream lightning protection steps and to limit system-induced or system-generated overvoltage surges.

HAW566 devices are primarily used in process automation for measurement and communication technology within the chemical, pharmaceutical, water and wastewater industries as well as in the food industry.

Your benefits

- Increased plant availability as surge protective device is perfectly matched to the electronic components involved in process automation and process measuring technology.
- Protection of investment-intensive measuring devices.
- Optional available with intrinsically safe approvals for the application in Ex areas.
- Optional available with SIL3

Function and system design

Operating principle

The HAW566 surge protective device is used to protect electronic components from being destroyed by overvoltage. It ensures that overvoltage surges which occur in signal cables (e.g. 4 to 20 mA), in communication lines (Field buses) and in power lines are safely passed into the ground.

The functionality of the transmitter or the electronics component to be protected is not affected.

Operation of power supply protective devices:

Using the impedance-free connection of the protective device, interference voltage drops cannot be introduced on the power lines.

Operation of signal cable protective devices:

Low and matched disconnection impedance between the individual protective steps within the unit guarantee high compatibility with the system to be protected.

Available versions

For power lines:

- HAW566-AADP1x to protect power lines in non-Ex areas, voltage range 10-55 V
- HAW566-AADP2~P5x to protect power lines in non-Ex areas, voltage range 90-230 V

For signal cables and communication lines:

- HAW566-AACx to protect signal cables in non-Ex areas
- Ex ia approval to protect signal cables

System construction

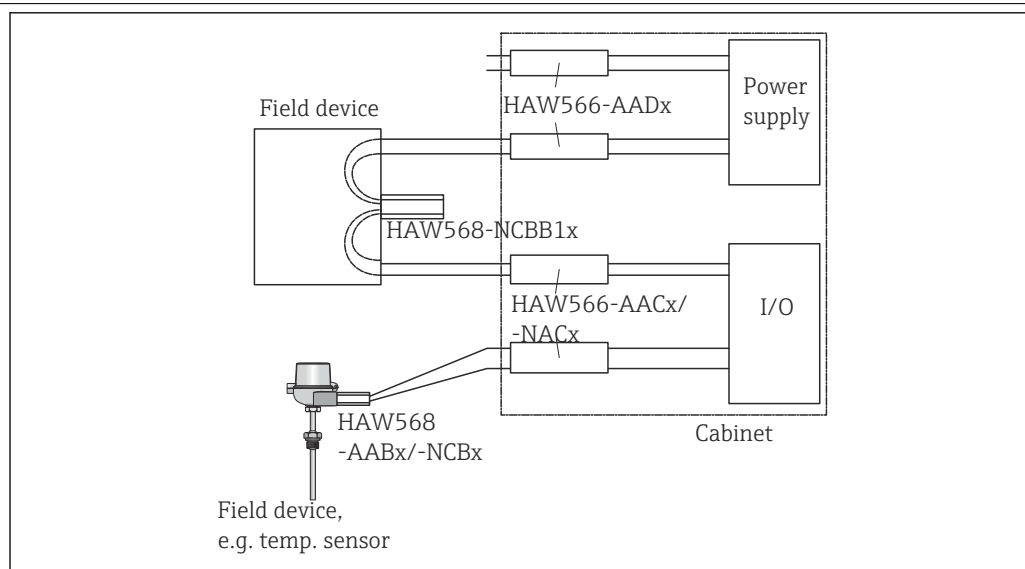

1 Overview of system construction, HAW566 and HAW568

Application

Overvoltage protection of various measurement instrumentation seen in the example of a water treatment plant.

Conditions for the installation of surge protective devices in a water treatment plant are:

- Lightning protection of plant and buildings
- Lightning protection of the main power supply distribution circuits in accordance with local regulations
- Low impedance foundation grounding
- Linked grounding of all buildings and plant

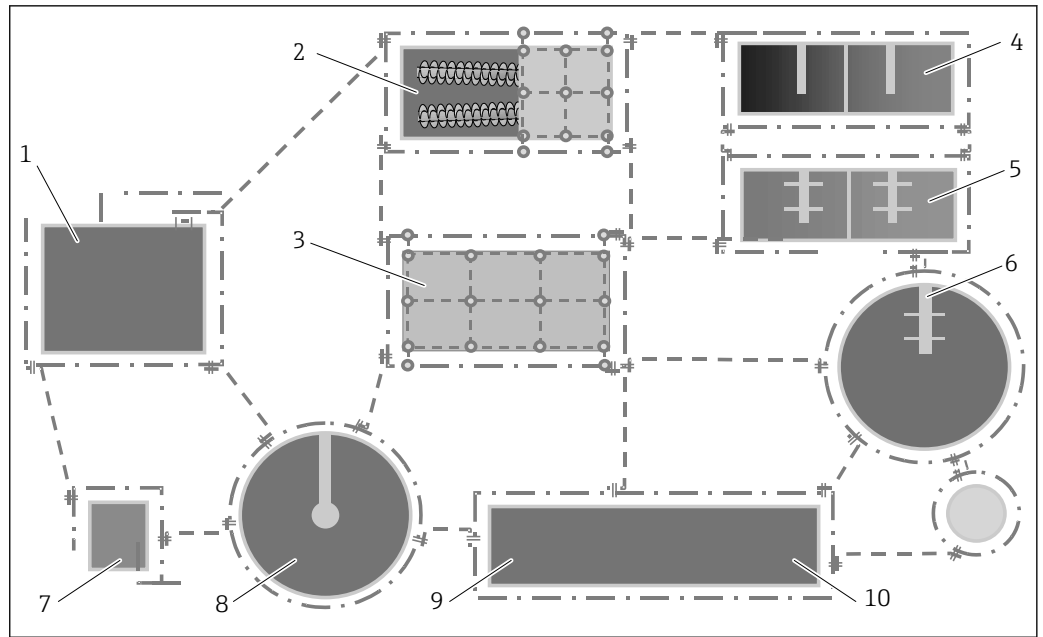

A0056925

2 Linked grounding (schematic diagram)

- 1 Storm overflow tank
- 2 Pump house
- 3 Plant control
- 4 Rough/fine rake
- 5 Sand/fat trap
- 6 Primary clarifier tank
- 7 Outfall shaft
- 8 Final clarifier tank
- 9 Activation tank
- 10 Denitrification

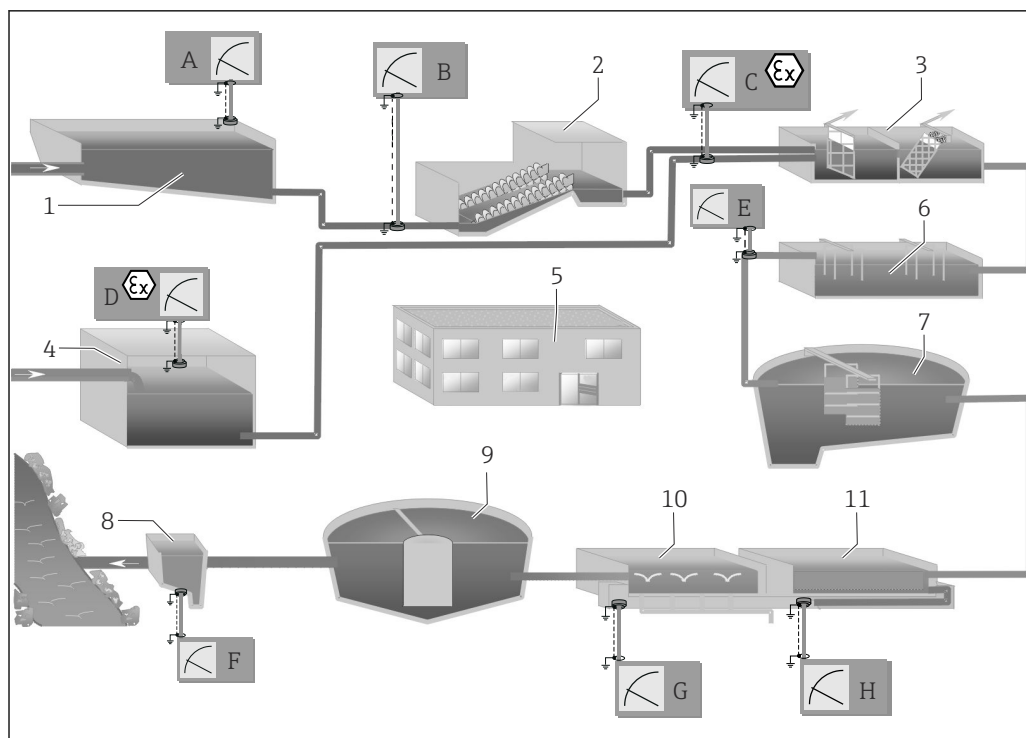

A0048704

3 Water treatment example (schematic diagram: Measurement points and measured variables)

- 1 Storm overflow tank (A: Level + quantity)
- 2 Pump house (B: Level + quantity)
- 3 Rough/fine rake (C: Pressure)
- 4 Fecal matter reception (D: Level)
- 5 Plant control
- 6 Sand/fat trap
- 7 Primary clarifier tank (E: pH value + temperature)
- 8 Outfall shaft (F: pH value + temperature)
- 9 Final clarifier tank
- 10 Activation tank (G: O₂ value)
- 11 Denitrification (H: Quantity)

Fitting out measuring points in a water treatment plant

Application	Sample measuring point	Measuring point requirements	Connection diagram
Storm overflow tanks Level and overflow quantity	<ul style="list-style-type: none"> ■ Level measurement: 0/4 to 20 mA ■ Overflow quantity measurement: 0/4 to 20 mA 	<ul style="list-style-type: none"> ■ 2 x HAW566-AACB1x for 0/4 to 20 mA remote signal ■ 1 x HAW566-AADPx for power supply to the transducer 	See connection diagram 1
Pumping system Quantity	Quantity measurement: 0/4 to 20 mA FlexView FMA90 with Micropilot FMR20B level measurement sensors	<ul style="list-style-type: none"> ■ 1 x HAW566-AACB1x for 0/4 to 20 mA signals ■ 1 x HAW566-AADPx for power supply to the transducer 	See connection diagram 2
Pump station	Level measurement: FlexView FMA90 with Micropilot FMR20B level measurement sensor	1 x HAW566-AADPx for power supply to the transducer	See connection diagram 3
Pipe Intrinsically safe pump pressure monitoring	Pressure measurement: 4 to 20 mA Cerabar S pressure transmitter	1 x HAW566-NACB1x for 4 to 20 mA remote signal in Ex area.	See connection diagram 4

Application	Sample measuring point	Measuring point requirements	Connection diagram
Primary clarification tank pH value + temperature	pH/temperature value measurement: Profibus PA or Profibus DP Liquisys M CPM253 transmitter with CYA112 and CPS11 measuring sensors	<ul style="list-style-type: none"> 1 x HAW566-AACB2x for Profibus PA or Profibus DP 1 x HAW566-AADPx for power supply to the transducer 	See connection diagram 5
Denitrification Recirculation quantity	Flow measurement: 0/4 to 20 mA Modbus RS485 Promag W 10 flowmeter	<ul style="list-style-type: none"> 1 x HAW566-AACB1x for 0/4 to 20 mA remote signal 1 x HAW566-AACA1x for Modbus RS485 1 x HAW566-AADPx for power supply to the transducer 	See connection diagram 6
Activation tank Dissolved oxygen	Oxygen content measurement: 0/4 to 20 mA Liquisys M CPM253 transmitter with COS41 measuring sensor	<ul style="list-style-type: none"> 1 x HAW566-AACB1x for 0/4 to 20 mA remote signal 1 x HAW566-AADPx for power supply to the transducer 	See connection diagram 5
Outfall pH value and temperature	pH/temperature value measurement: Profibus PA or Profibus DP Liquisys M CPM253 transmitter with CYA112 and CPS11 measuring sensors	<ul style="list-style-type: none"> 1 x HAW566-AACB2x for Profibus PA or Profibus DP 1 x HAW566-AADPx for power supply to the transducer 	See connection diagram 5
Other application example: Flow measurement	E.g. Coriolis Promass F 200, 300, 500; T-mass, F 300, 500 & I 300, 500; Prosonic 92F or W 400	1 HAW568-NCBBx4x for power supply and signal cable	See connection diagram 7

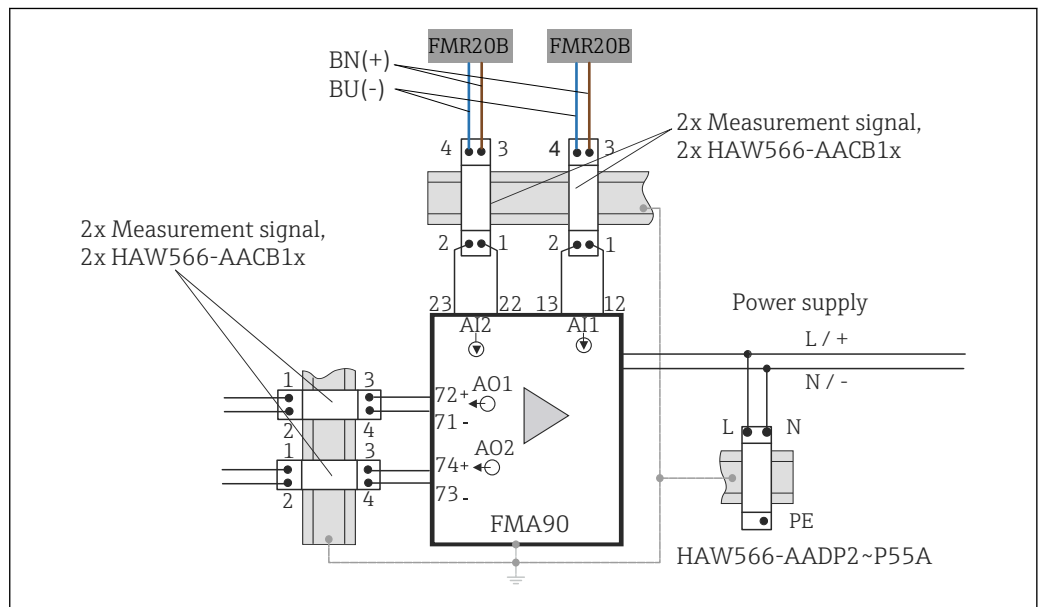

4 Connection diagram 1: Level measurement with FlexView FMA90 with 2 Micropilot FMR20B level sensors

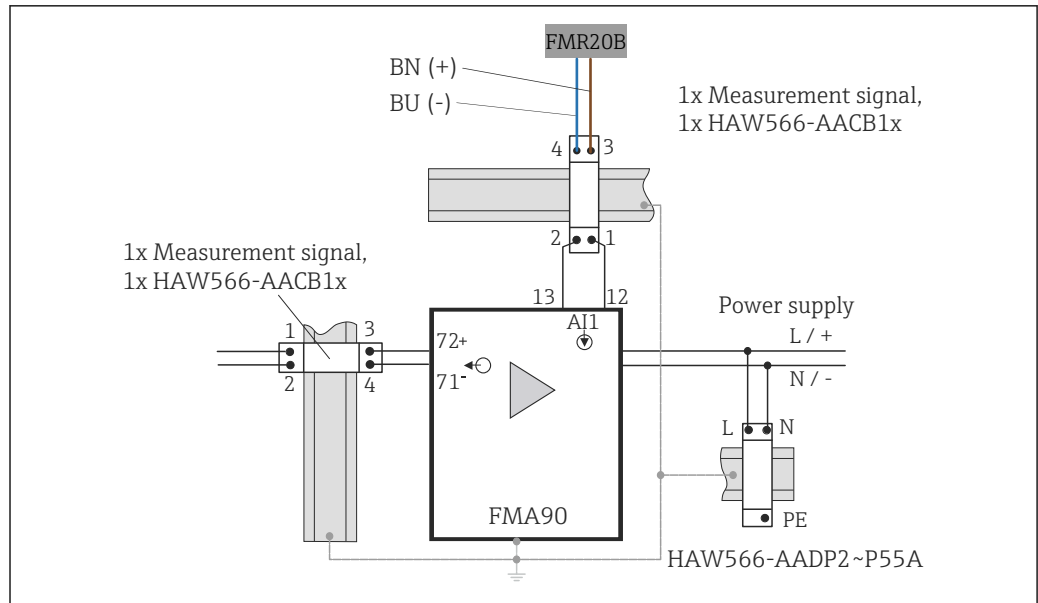

5 Connection diagram 2: Level measurement with FlexView FMA90 with Micropilot FMR20B level sensor

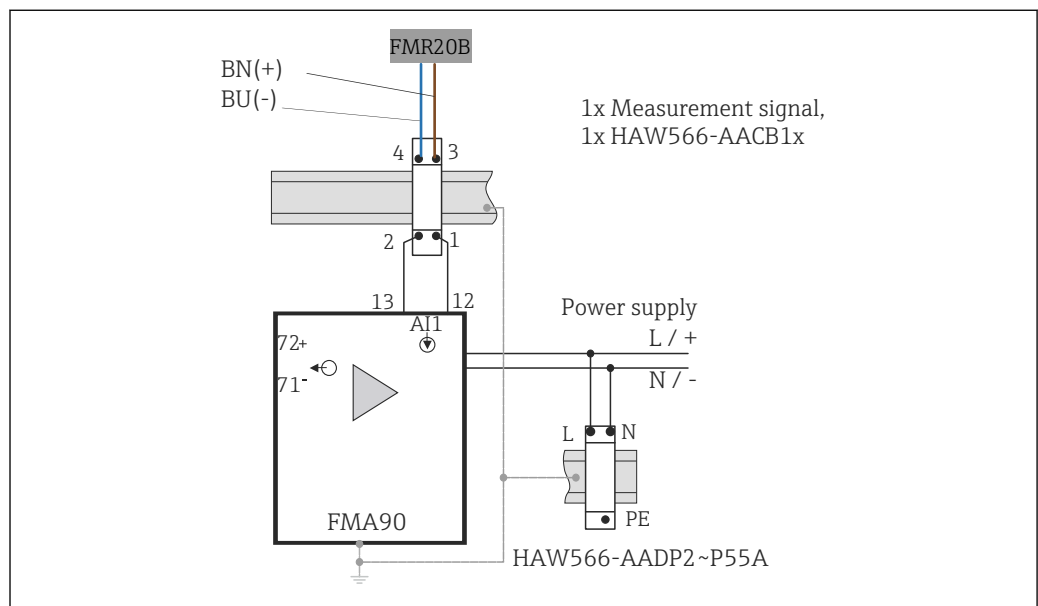

6 Connection diagram 3: Level measurement with FlexView FMA90 with Micropilot FMR20B level sensor

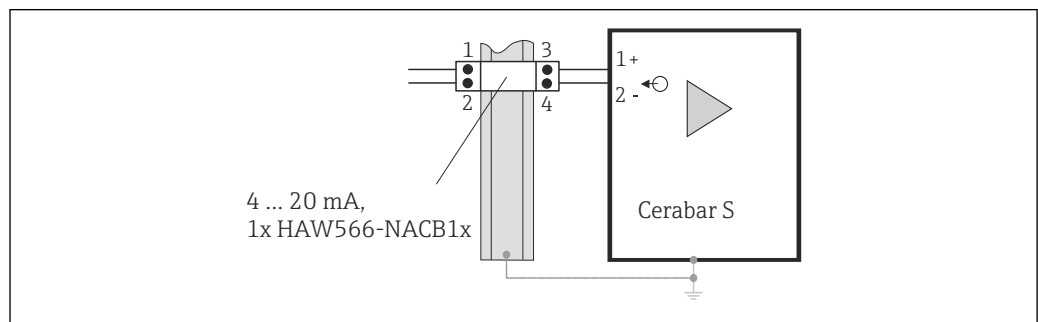

7 Connection diagram 4: Pressure measurement with Cerabar S pressure transmitter with 4 ... 20 mA

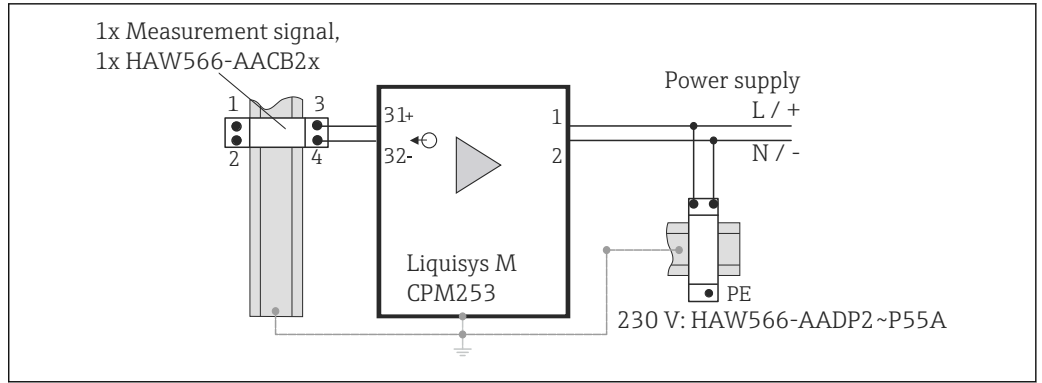

A0056714

8 Connection diagram 5: pH value and temperature measurement with M CPM253 with CYA112 and CPS11 measuring sensors, Profibus PA or Profibus DP

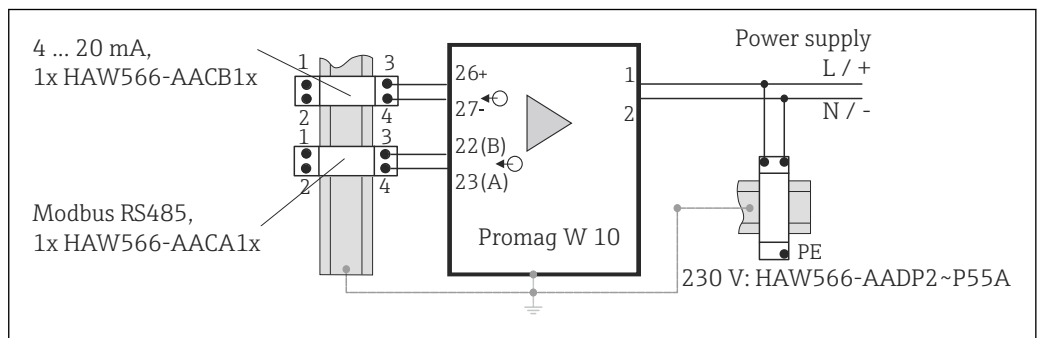

A0056715

9 Connection diagram 6: Flow measurement with Promag W 10 with 4 ... 20 mA and Modbus RS485

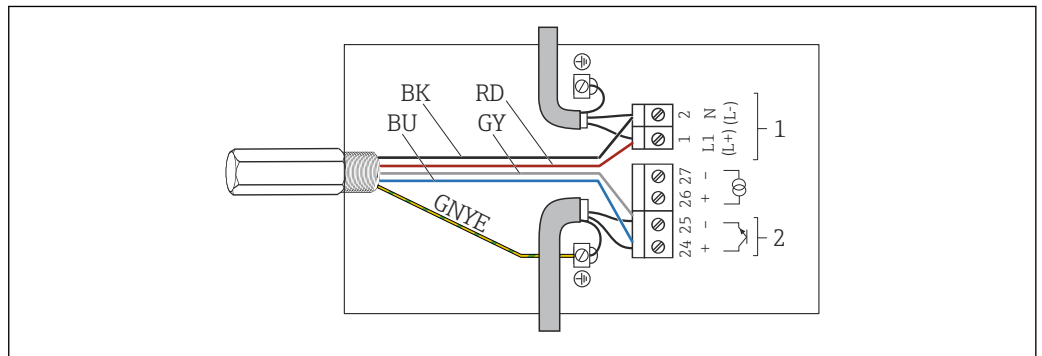

A0056659

10 Connection diagram 7: HAW568-AABB24x with Power+Pulse output for flow measurement, e.g. Coriolis Promass F 200, 300, 500; T-mass F 300, 500, I 300, 500; Prosonic 92F or W 400

- 1 Power supply line
- 2 Pulse output

Power supply

Electrical connection

HAW566 for signal lines

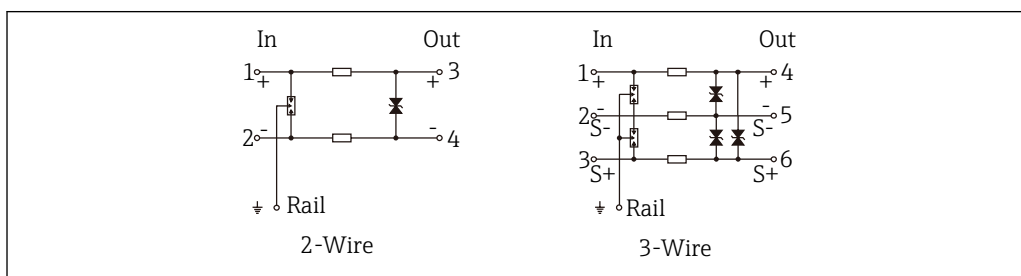

A0056717

11 HAW566 internal circuitry for signal lines

HAW566 for power lines

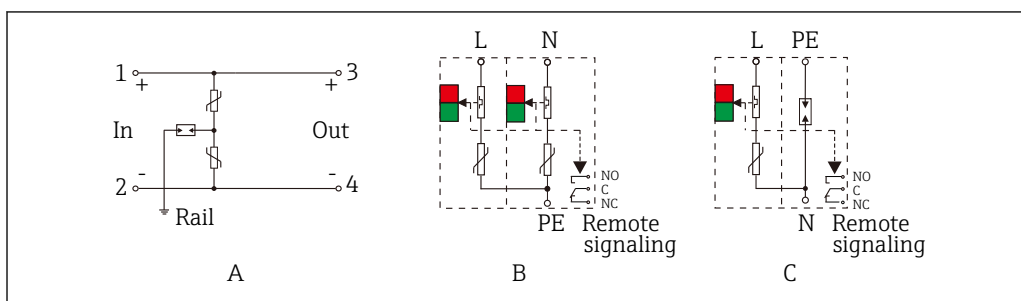

A0056721

12 HAW566 internal circuitry for power lines

- A 24 V_{DC} Power ($\leq 10 A$)
- B 230 V_{AC} Power Single phase TN earthing system
- C 230 V_{AC} Power Single phase TT earthing system

Connection instructions

2-wire signal installation

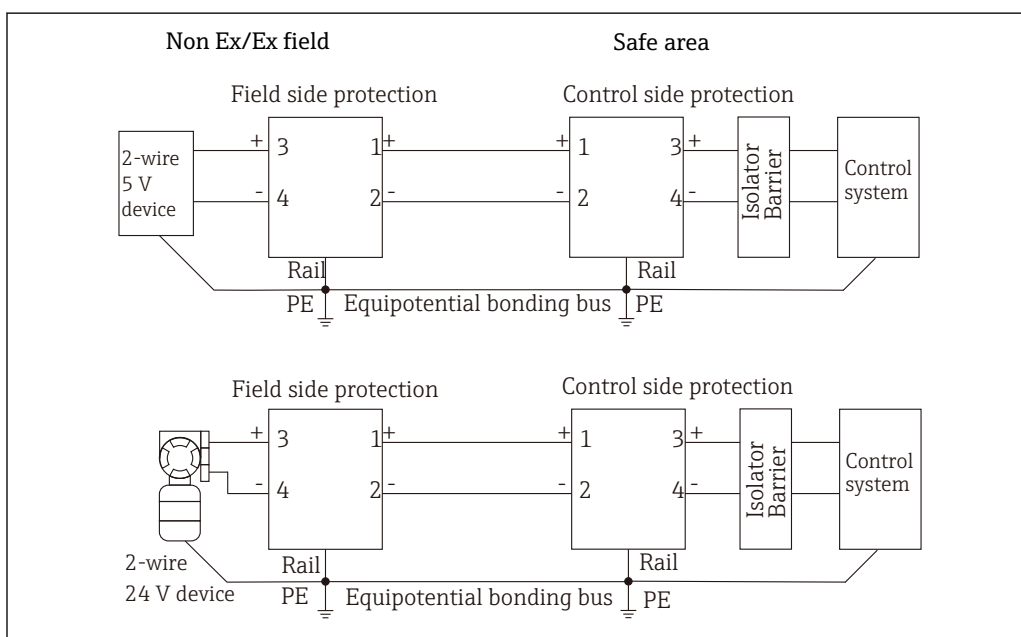

A0056722

13 HAW566, 2-wire signal installation

3-wire signal installation

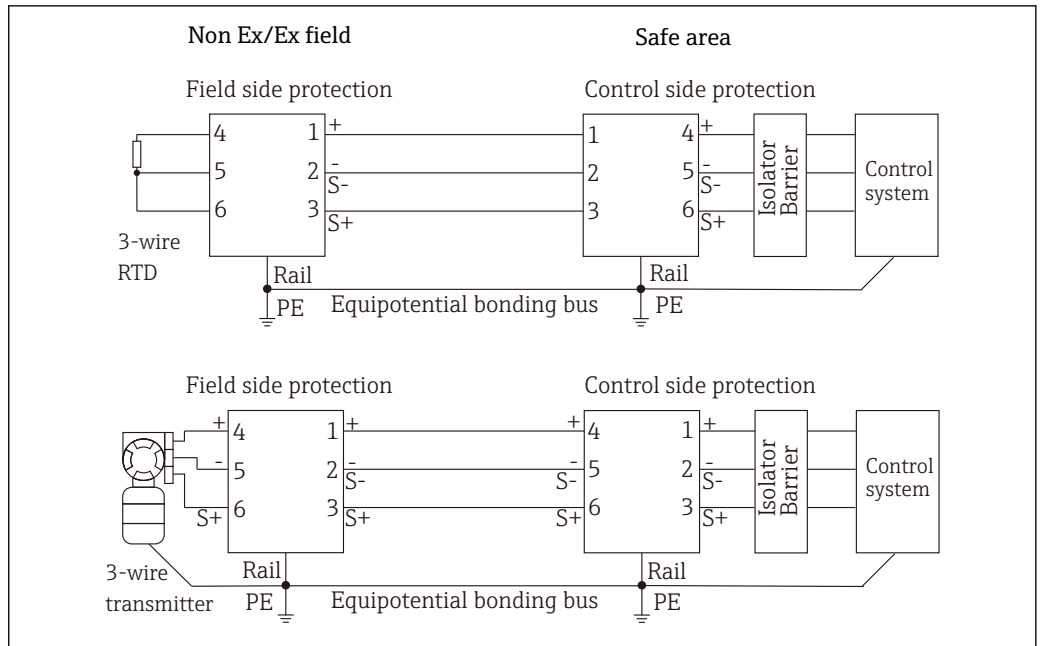

A0056723

14 HAW566, 3-wire signal installation

Installation in 24 V power lines

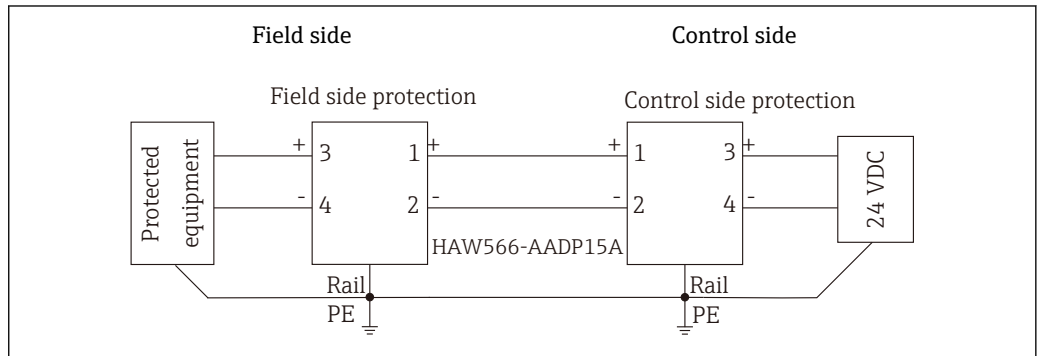

A0056723

15 HAW566, installation in 24 V power lines

Installation in 230 V power lines

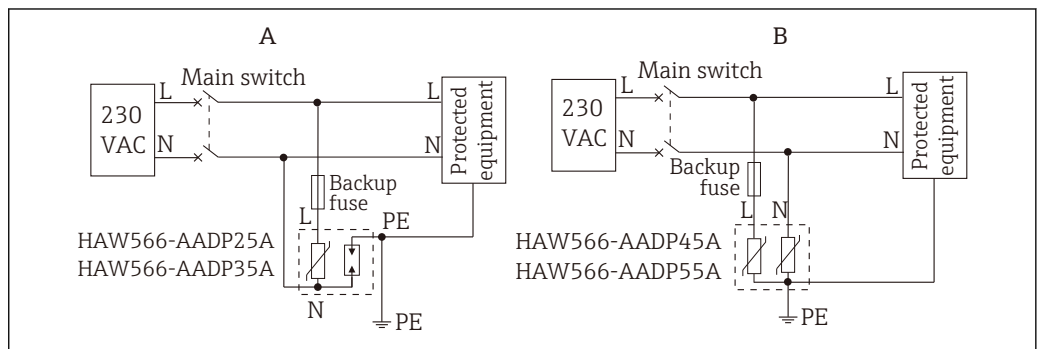

A0056727

16 HAW566, installation in 230 V power lines

- A TT earthing system (single phase)
- B TN earthing system (single phase)

Back-up fuses are recommended to be installed in case the unit gets short-circuited and the recommended back-up fuse is 40 A gG.

For connecting to L/N, cables with a cross-sectional area $\geq 2.5 \text{ mm}^2$ are recommended.

For connecting to PE, cables with a cross-sectional area $\geq 4 \text{ mm}^2$ are recommended.

SPD class	HAW566		
	-*C	-AADP1	-AADP2~P5
	C2, D1	C2, D1	Type 2

Supply voltage

Nominal voltage

HAW566			
-*CA1,A2	-*CB1~B4	-AADP1	-AADP2~P5
5 V	24 V	24 V	230 V

Maximum continuous voltage U_c

	HAW566			
	-*CA1,A2	-*CB1~B4	-AADP1	-AADP2~P5
DC:	6 V	32 V	24 V	230 V

Current consumption

	HAW566			
	-*CA1,A2	-*CB1~B4	-AADP1	-AADP2~P5
Nominal current [I_L]	0.5 A, Ex 0.8 A, Non-Ex	0.5 A, Ex 0.8 A, Non-Ex	10 A	-
C2 nominal discharge current [I_n] (8/20) per line	10 kA	10 kA	10 kA	10 kA
C2 nominal discharge current [I_{max}] (8/20) total	20 kA	20 kA	20 kA	20 kA
Short circuit withstand capability at mains-side overcurrent protection with 40 A gL/gG (I_{SCCR})	-	-	-	1 kA
D1 lightning surge current [I_{imp}] (10/350)	2.5 kA	2.5 kA	2.5 kA	-

Voltage protection level Up

	HAW566			
	-**CA1,A2	-**CB1~B4	-AADP1	-AADP2~P5
Line/line	$\leq 40 \text{ V}$	$\leq 60 \text{ V}$	$\leq 400 \text{ V}$	$\leq 1200 \text{ V}$
Line/PG	$\leq 700 \text{ V}$	$\leq 700 \text{ V}$	$\leq 750 \text{ V}$	$\leq 1200 \text{ V}$

Terminals

	HAW566-**C, HAW566-AADP1	HAW566-AADP2~P5
Single strand cables	0.2 to 4 mm ² (24 to 12 AWG)	2.5 to 25 mm ² (13 to 4 AWG)
Multi strand cables	0.2 to 2.5 mm ² (24 to 14 AWG)	2.5 to 16 mm ² (13 to 5 AWG)

Performance characteristics

Response times	HAW566			
	-*CA1,A2	-*CB1~B4	-AADP1	-AADP2~P5
Line/line	≤ 1 ns	≤ 1 ns	≤ 25 ns	-
Line/PG	≤ 100 ns	≤ 100 ns	≤ 100 ns	≤ 25 ns

Limit frequency	HAW566			
	-*CA1,A2	-*CB1~B4	-AADP1	-AADP2~P5
45 MHz	45 MHz	-	-	-

Series impedance per line	HAW566			
	-*CA1,A2	-*CB1~B4	-AADP1	-AADP2~P5
1.0 Ω	1.0 Ω	-	-	-

Capacitance	HAW566			
	-*CA1,A2	-*CB1~B4	-AADP1	-AADP2~P5
Line/line	~ 0 nF	~ 0 nF	-	-
Line/PG	≤ 15 pF	≤ 15 pF	-	-

Leakage current	HAW566-*CB1~B4	HAW566-*CA1,A2	HAW566-*DP1~P5
	≤ 1 μA	≤ 10 μA	≤ 20 μA

Maximum line side overcurrent protection Only for unit types HAW566-AADP2~P5:
40 A gG

Installation

Installation instructions

Mounting location

Installation on 35 mm top hat rail to EN 60715

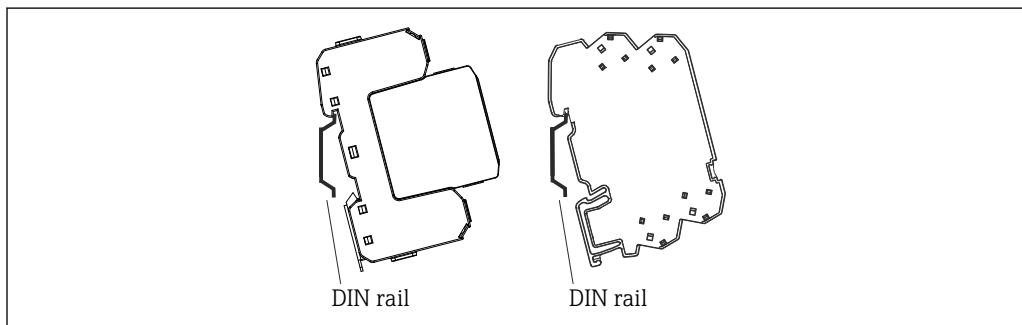

A005665

17 Installation on top hat rail, drawing as example. Left: Device for power lines, right: Device for signal lines

Multiple unit installation

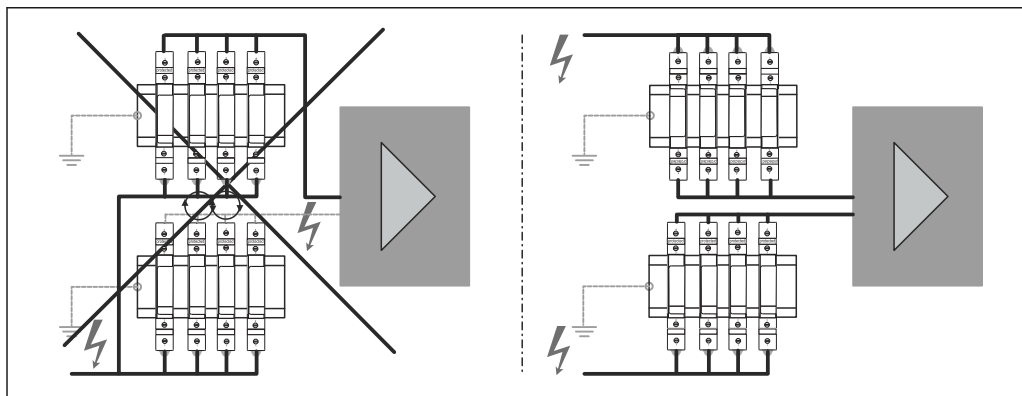

A0056743

18 Multiple unit installation

Environment

Ambient temperature range -40 to +80 °C (-40 to +176 °F)

Humidity 5 to 90 %

Storage temperature -40 to +85 °C (-40 to +185 °F)

Degree of protection IP 20

Other standards and guidelines

- IEC 61010:
Safety requirements for electrical equipment for measurement, control and laboratory use
- IEC 61326:
Electromagnetic compatibility (EMC requirements)

HAW566-AADP2-P5	HAW566-*C, HAW566-AADP1
IEC 61643-1 EN 61643-11	IEC 61643-21 C2, D1

Mechanical construction

Design, dimensions

HAW566-*CA1&A2, HAW566-*CB1~B4, HAW566-AADP1

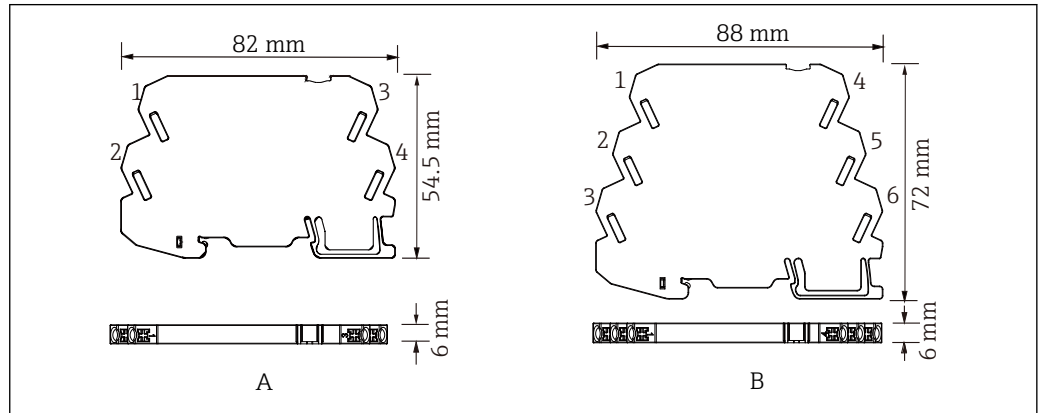

19 Dimensions in mm

- A 2-wire
- B 3-wire

HAW566-AADP2~P5

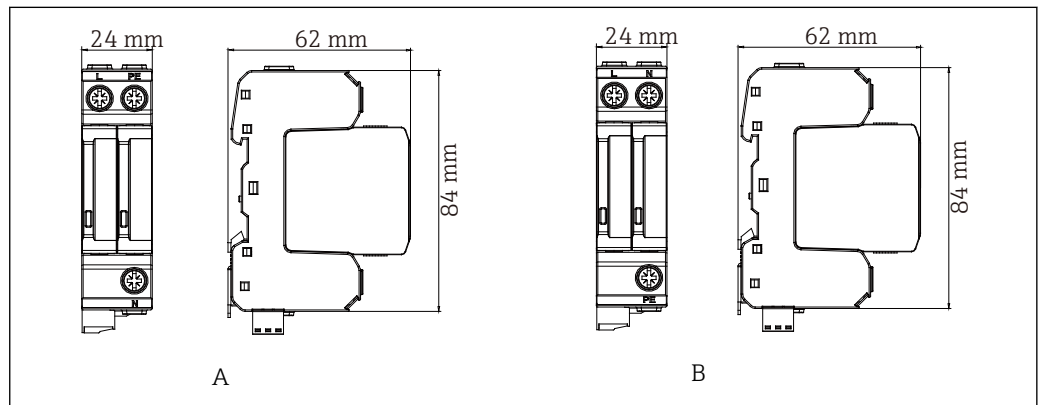

20 Dimensions in mm

- A TT earthing system 1P+N
- B TN earthing system 2P

Weight

HAW566-*CA1, HAW566-AADP1, HAW566-*CB1~B4 (2-wire)	HAW566-*CA2, HAW566-*CB1&B4 (3-wire)	HAW566-AADP2~P5
20 g	28 g	136 g

Material

Polyamide PA 66/V0

Operability

Display elements

HAW566-AADP2~P5

Green display (= functional) in sight window. The energy transfer of the units is controlled by the integrated thermal monitoring system. In the event of a defect (= red display window - means thermal overload) this monitoring system will automatically separate the surge protective device from the power source.

All other HAW566 units do not have any display elements.

NOTICE

Defective surge protective device

Electric units connected are then no longer protected from overvoltages.

- ▶ Replace the surge protective device immediately.

HAW566-*C, HAW566-AADP1

These units do not have any display elements.

NOTICE

Defective surge protective device

Signal cable short circuit.

- ▶ The short circuit is rectified when the defective protection module is taken out of the carrier.
Electric units connected are no longer protected from overvoltages. Replace the surge protective device immediately.

Certificates and approvals

Current certificates and approvals for the product are available at www.endress.com on the relevant product page:

1. Select the product using the filters and search field.
2. Open the product page.
3. Select **Downloads**.

Ex approval

Information about currently available Ex versions (CCC etc.) can be supplied by your Endress+Hauser Sales Center on request. All explosion protection data are given in separate documentation which is available upon request.

Standards

- IEC 61643-21:
Low voltage surge protective devices
- IEC 61508:
Functional safety of electrical/electronic/programmable electronic safety-related systems
- IEC 60529:
Degree of protection provided by housing (IP code)
- IEC/EN 60079:
General requirements for construction, testing and marking of Ex Equipment and Ex Components intended for use in explosive atmospheres

Other standards and guidelines

- GB/T 18802.21: China
Low voltage surge protective devices
- GB 3836: China
General requirements for construction, testing and marking of Ex Equipment and Ex Components intended for use in explosive atmospheres

Ordering information

Detailed ordering information is available from your nearest sales organization www.addresses.endress.com or in the Product Configurator at www.endress.com:

1. Select the product using the filters and search field.
2. Open the product page.

3. Select Configuration.



Product Configurator - the tool for individual product configuration

- Up-to-the-minute configuration data
- Depending on the device: direct input of information specific to the measuring point, such as the measuring range or operating language
- Automatic verification of exclusion criteria
- Automatic creation of the order code and its breakdown in PDF or Excel output format
- Ability to order directly in the Endress+Hauser Online Shop

Documentation

The following document types are available in the Downloads area of the Endress+Hauser website (www.endress.com/downloads), depending on the device version:

Document type	Purpose and content of the document
Technical Information (TI)	Planning aid for your device The document contains all the technical data on the device and provides an overview of the accessories and other products that can be ordered for the device.
Brief Operating Instructions (KA)	Guide that takes you quickly to the 1st measured value The Brief Operating Instructions contain all the essential information from incoming acceptance to initial commissioning.
Operating Instructions (BA)	Your reference document The Operating Instructions contain all the information that is required in various phases of the life cycle of the device: from product identification, incoming acceptance and storage, to mounting, connection, operation and commissioning through to troubleshooting, maintenance and disposal.
Description of Device Parameters (GP)	Reference for your parameters The document provides a detailed explanation of each individual parameter. The description is aimed at those who work with the device over the entire life cycle and perform specific configurations.
Safety instructions (XA)	Depending on the approval, safety instructions for electrical equipment in hazardous areas are also supplied with the device. These are an integral part of the Operating Instructions. The nameplate indicates which Safety Instructions (XA) apply to the device.
Supplementary device-dependent documentation (SD/FY)	Always comply strictly with the instructions in the relevant supplementary documentation. The supplementary documentation is a constituent part of the device documentation.



71749277

www.addresses.endress.com
