

Operating Instructions

FLWSIC600

Ultrasonic Gas Flow Meter



Described product

Product name: FLOWVIC600

Manufacturer

Endress+Hauser SICK GmbH+Co. KG
 Bergener Ring 27
 01458 Ottendorf-Okrilla
 Germany

Legal information

This work is protected by copyright. Any rights derived from the copyright shall be reserved for Endress+Hauser SICK GmbH+Co. KG. Reproduction of this document or parts of this document is only permissible within the limits of the legal determination of Copyright Law. Any modification, abridgment or translation of this document is prohibited without the express written permission of Endress+Hauser SICK GmbH+Co. KG. The trademarks stated in this document are the property of their respective owner.

© Endress+Hauser SICK GmbH+Co. KG. All rights reserved.

Original document

This document is an original document of Endress+Hauser SICK GmbH+Co. KG.



Glossary

Abbreviations used in this manual

act.	actual (under operating/flowing conditions)
AGC	A utomatic G ain C ontrol
ANSI	A merican N ational S tandards I nstitute
ASCII	A merican S tandard C ode for I nformation I nterchange
ASME	A merican S ociety of M echanical E ngineers
ATEX	A tmosphères E xplosifs: Abbreviation for European standards that govern safety in potentially explosive atmospheres
AWG	A merican W ire G age
CBM	C ondition B ased M aintenance
CSA	C anadian S tandards A ssociation
DC	D irect C urrent
DIN	D eutsches I nstitut für N ormung
DN	N ominal D iameter (internal)
DSP	D igital S ignal P rocessor
EC	E uropean C ommunity
EMC	E lectro M agnetisc C ompatibility
EN	E uro N orm (European Standard)
EVC	E lectronic V olume C orrector
Ex	Potentially ex plosive atmosphere
FLOWgate™	User friendly software for diagnosis and parameterization of Endress+Hauser measuring systems
HART®	Communication interface
IEC	I nternational E lectrotechnical C ommission
IECEX	EC system for certification in accordance with standards for devices for use in potentially explosive atmospheres
LCD	L iquid C rystal D isplay
LED	L ight E mitting D iode
MDR	M anufacturer D ata R ecord
NAMUR	N ormenarbeitsgemeinschaft für M ess- und R egeltechnik in der chemischen Industrie (now "Interessengemeinschaft Prozessleittechnik der chemischen und pharmazeutischen Industrie"; ~ Association for Instrumentation and Control Standards in the Chemical Industry)
norm.	normal ized/corrected (under standard conditions)
OI	O perating I nstructions
OIML	O rganisation I nternationale de M etrologie L egale
PC	P ersonal C omputer
Reg. #	R egister number
RTU	R emote T erminal U nit
SNR	S ignal N oise R atio
SPU	S ignal P rocessing U nit
VDE	V erband d er E lektrotechnik E lektronik I nformationstechnik (~ Association of German Electrical Engineers)

Warning Symbols



Hazard (general)



Hazard in potentially explosive atmospheres



Hazard by voltage

Warning Levels / Signal Words

WARNING

Risk or hazardous situation which *could* result in severe personal injury or death.

CAUTION

Hazard or unsafe practice which *could* result in personal injury or property damage.

NOTICE

Hazard which *could* result in property damage.

Information Symbols



Information about the use in potentially explosive atmospheres



Important technical information for this product



Important information on electric or electronic functions



Supplementary information



Link to information at another place

- 1 Important Information** 7
 - 1.1 About this document 8
 - 1.2 Scope of document 8
 - 1.3 Safety instructions 9
 - 1.3.1 Intended use of the equipment 9
 - 1.4 Authorized staff 9
 - 1.5 General safety instructions and protective measures 10
 - 1.6 Dangers due to hot, corrosive and explosive gases and high pressure 10
 - 1.7 Dangers due to heavy loads 11
 - 1.8 Environmental information and instructions for disposal 11

- 2 Product Description** 13
 - 2.1 System components 14
 - 2.1.1 Meter body 14
 - 2.1.2 Ultrasonic transducers 15
 - 2.1.3 Signal processing unit 15
 - 2.2 Operating modes, meter states and signal output 16
 - 2.2.1 Operation mode and configuration mode 16
 - 2.2.2 Meter states 17
 - 2.2.3 Output of pulse signals and status information 18
 - 2.3 Self-diagnosis with User Warnings 20
 - 2.4 Data handling in the FLOWSIC600 21
 - 2.4.1 Integrated volume counters 21
 - 2.4.2 Logbooks 22
 - 2.4.3 DataLogs 23
 - 2.4.4 Diagnostics Comparison Log 24
 - 2.5 FLOWgate™ 25
 - 2.5.1 System requirements 25
 - 2.5.2 Overview 26

- 3 Installation** 29
 - 3.1 General notes 30
 - 3.1.1 Delivery 30
 - 3.1.2 Transport and storage 31
 - 3.2 Installation 32
 - 3.2.1 Measuring location 32
 - 3.2.2 Installation configurations 33
 - 3.3 Mechanical installation 35
 - 3.3.1 Choosing flanges, seals and other parts 35
 - 3.3.2 Mounting the FLOWSIC600 in the piping 36
 - 3.3.3 SPU alignment 37
 - 3.4 Electrical installation 38
 - 3.4.1 General information 38
 - 3.4.2 Cable specifications 40
 - 3.4.3 Checking the cable loops 41
 - 3.4.4 Terminal enclosure on the SPU 42
 - 3.4.5 Operating the FLOWSIC600 in non-hazardous areas 44
 - 3.4.6 Requirements for use in hazardous areas with potentially explosive atmospheres 45

4	Commissioning	57
4.1	General notes.....	58
4.2	Connecting the FLOWSIC600 to a PC or laptop.....	59
4.2.1	Connecting the FLOWSIC600 via RS485 / RS232 cable.....	59
4.2.2	Connecting the FLOWSIC600 via RS485/USB converter.....	60
4.3	Connecting to the FLOWSIC600 with FLOWgate™.....	61
4.3.1	Starting FLOWgate™.....	61
4.3.2	Creating a new meter entry in the meter database.....	61
4.3.3	Online connection: Direct serial.....	62
4.3.4	Online connection: Ethernet.....	64
4.4	Identification.....	66
4.4.1	Firmware.....	66
4.5	Field setup.....	67
4.5.1	Disconnecting from the meter and closing the session.....	68
4.6	Function test.....	69
4.6.1	Function test on FLOWSIC600 with LCD front panel.....	69
4.6.2	Function test on FLOWSIC600 with LED front panel.....	69
4.6.3	Function test with FLOWgate™.....	70
4.7	Optional advanced setup.....	72
4.7.1	Configuration and activation of User Warnings.....	72
4.7.2	Configuration of DataLogs.....	73
4.7.3	Configuring and using the Diagnostics Comparison Log.....	77
4.8	Activation of path compensation.....	80
4.8.1	Sealing.....	80
4.9	Documentation.....	80
5	Maintenance	81
5.1	General.....	82
5.2	Routine checks.....	83
5.2.1	Comparing theoretical and measured Speed of Sound (SOS).....	83
5.2.2	Checking the meter health.....	84
5.2.3	Time synchronization.....	85
5.2.4	Battery lifespan / capacity.....	86
5.3	Maintenance report.....	87
5.4	Optional data download.....	88
5.4.1	Logbook check.....	88
5.4.2	DataLogs check.....	90
6	Troubleshooting	93
6.1	General troubleshooting.....	94
6.2	Indication of meter states, system alarms and warnings.....	94
6.2.1	Checking the "Meter Status" window.....	95
6.2.2	Checking the "User Warnings" window.....	97
6.2.3	Checking the diagnostic meter values.....	98
6.2.4	Battery lifespan / capacity.....	99
6.3	Creating a diagnostic session with FLOWgate™.....	99
6.4	Meter connection troubleshooting.....	101

7	Appendix	103
7.1	Conformities and technical data	104
7.1.1	CE certificate	104
7.1.2	Standard compatibility and type approval	104
7.1.3	WELMEC compliance	104
7.1.4	Common meter sizes and flow rates	106
7.1.5	Technical data	107
7.1.6	Application specific technical data	109
7.2	Design pressure and design temperature	117
7.3	Characteristic properties and dimensions of the meter body	118
7.4	Operation and menu structure of the SPU with LCD display	124
7.4.1	Operation	124
7.4.2	Menu structure on the LCD display	125
7.4.3	Display of measured values	133
7.4.4	Data editing in Configuration Mode	134
7.4.5	Resetting the error volume counters	135
7.4.6	Acknowledging a battery replacement	135
7.5	Logbooks	136
7.5.1	Overview of event entries in meter logbooks	137
7.5.2	Acknowledging a logbook entry on the LCD display	140
7.6	SPU terminal assignment	141
7.7	Connection diagrams for operating the FLOWSIC600 in hazardous areas in accordance with North American Requirements (NEC, CEC)	143
7.8	Wiring examples	149
7.8.1	Intrinsically safe installation	149
7.8.2	Non-intrinsically safe installation	150
7.9	Sealing plan	151

FLOWSIC600

1 Important Information

About this document

Scope of document

Safety instructions

Authorized staff

General safety instructions and protective measures

Dangers due to hot, corrosive and explosive gases and high pressure

Dangers due to heavy loads

Environmental information and instructions for disposal

1.1 About this document

This manual describes the FLOWSIC600 measuring system, which is used to determine the volumetric flow rate, volume and speed of sound in gases transported in pipelines. It provides general information on the measuring method employed, design and function of the entire system and its components, on planning, assembly, installation, calibration commissioning, maintenance and troubleshooting. A detailed description of the various system capabilities, options and settings which will assist in optimizing the meter configuration for a specific application is also included.

This manual covers standard applications which conform with the technical data specified. Additional information and assistance for special applications are available from your Endress+Hauser representative. However, it is generally recommended that advantage be taken of qualified consulting services provided by Endress+Hauser experts for your specific application.

This manual is a part of the FLOWSIC600 device documentation.

Documentation available from your local representative:

- FLOWSIC600 MODBUS specification document
- FLOWSIC600 HARTbus specification document
- FLOWSIC600 Technical Bulletin ENCODER Output
- Operating Instructions FLOWSIC600 DRU/DRU-S

Documentation available from your local representative after training:

- FLOWSIC600 service manual
- FLOWSIC600 extraction tool operating instructions

1.2 Scope of document



This document applies to meters with firmware version 3.6.00 or higher and extended memory for the storage of e.g. hourly and daily mean values. The software description in this document applies to FLOWgate™ V1.29.

The following terms will be used for measurands:

Measurand	Basic abbreviations and units for FLOWSIC600			Abbreviations used for LCD-Display of SPU			FLOWgate™ software		
Volume at flowing conditions	Vf	m ³	acf	Vf	m ³	cf	Vf	m ³	acf
Volume at base conditions	Vb	Nm ³	scf	Vb	m ³	cf	Vb	Nm ³	scf
Error volume at flowing conditions	Ef	m ³	acf	Ef	m ³	cf	Ef	m ³	acf
Error volume at base conditions	Eb	Nm ³	scf	Eb	m ³	cf	Eb	Nm ³	scf
Total volume at flowing conditions	Vo	m ³	acf	Vo	m ³	cf	Vo	m ³	acf
Volume flow at flowing conditions	Qf	m ³ /h	acf/h	Qf	m ³ /h	cf/h	Qf	m ³ /h	acfh
Volume flow at base conditions	Qb	Nm ³ /h	scf/h	Qb	m ³ /h	cf/h	Qb	Nm ³ /h	scfh
Mass counter	M	t	lbs	M	t	lbs	M	t	lbs
Error Mass	Me	t	lbs	M	t	lbs	M	t	lbs
Mass flow at base conditions	Mf	t/h	lbs/h	M	t/h	lbs/h	M	t/h	lbs/h

1.3 **Safety instructions**

1.3.1 **Intended use of the equipment**

The FLOWSIC600 measuring system is used for measuring the actual volumetric flow rate of gases transported in pipelines. It can be used for measuring the actual corrected volume and the speed of sound in gases.

The measuring system shall only be used as specified by the manufacturer and as set forth below. Always observe the following information:

- Make sure the use of the equipment complies with the technical data, information about the permitted use, assembly and installation specifications and ambient as well as operating conditions. Relevant information is provided in the order documentation, type plate, certification documents and this manual.
- Any actions for the purpose of maintaining the value of the equipment, e.g. service and inspection, transport and storage etc., shall be performed as specified.
- Do not expose the equipment to mechanical stress, such as pigging.
- The flooding of the FLOWSIC600 with any liquid (e.g. for pressure or leakage tests) is deemed improper use. The consequences of such actions can not be foreseen or estimated. Improper use may result in failure of the ultrasonic transducers and consequently, failure of the entire flow meter.

Should it be necessary to flood the FLOWSIC600, please contact the manufacturer prior to doing so. In addition, the following instructions must be strictly adhered to:

	<p>WARNING:</p> <p>▶ The pressure during flooding may not exceed more than 1,2 times the nominal pressure (when transducers are assembled).</p>
--	--

1.4 **Authorized staff**

Persons responsible for safety shall ensure the following:

- Any work on the measuring system shall only be carried out by qualified staff and must be approved by skilled staff responsible for the plant.
Due to their professional training, knowledge and vocational experience, as well as their knowledge of the relevant standards, regulations, health and safety regulations and equipment conditions, qualified persons shall be assigned by the person responsible for personal and plant safety to carry out such work. Qualified persons must be able to identify possible dangers and to take preventive action in due time. Skilled persons are defined in DIN VDE 0105 and IEC 364, or comparable standards.
- Skilled persons shall have precise knowledge of process-specific dangers, e.g. due to the effects of hot, toxic and pressurized gases, gas-liquid mixtures and other process media, and of the design and working principle of the measuring system and shall have received and be able to document appropriate training.
- In hazardous areas with potentially explosive atmospheres, wiring and installation shall only be carried out by staff trained according to EN /IEC 60079-14 and according to national regulations.

1.5 **General safety instructions and protective measures**

Using the equipment for any purpose other than that intended by the manufacturer, or improper operation may result in injuries and damage to the equipment. Read this section and the notes and warnings in the individual sections of this manual carefully and observe the instructions contained therein when carrying out any work on the FLOWSIC600 measuring system.

General instructions to be adhered to:

- Always comply with the statutory provisions and the associated technical rules and regulations relevant to the equipment when preparing for and carrying out any work on the measuring system. Pay particular attention to potentially hazardous aspects of the equipment, such as pressurized piping and explosion protection zones. Always observe the relevant regulations.
- Always consider local and equipment-specific conditions and process-specific dangers when carrying out any work on the equipment.
- Operating and service instructions and equipment documentation shall always be available on site. Always observe the safety instructions and notes on the prevention of injuries and damage given in these manuals.
- Ensure appropriate protective accessories are available in sufficient supply. Always use such protective accessories. Check that appropriate safety devices are fitted and working correctly.

1.6 **Dangers due to hot, corrosive and explosive gases and high pressure**

The FLOWSIC600 measuring system is directly integrated into gas-carrying pipelines.

The operating company is responsible for safe operation and for complying with additional national and company-specific regulations.

**WARNING:**

In plants with toxic and explosive gases, high pressure or high temperatures, the FLOWSIC600 measuring system shall only be installed or removed after the associated piping has been isolated and depressurized (i.e. vented to atmosphere).

The same applies to repair and service work which involves opening any pressurized component or the explosion-proof signal processing unit (SPU).

**NOTICE:**

Design, manufacture and inspection of the FLOWSIC600 measuring system is performed in compliance with the safety requirements set forth in the European Pressure Equipment Directive 2014/68/EU.

1.7 **Dangers due to heavy loads**

The FLOWSIC600 measuring system must be safely attached to the carrying structure when being transported and installed.



WARNING:

- Only use lifting gear and equipment (e.g. lifting straps) which is suitable for the weight to be lifted. Max. load information can be found on the type plate of the lifting gear.
- The eye bolts attached to the meter body are suitable for the transport of the measuring device. However, additional loads (e.g. blind covers, filling for pressure tests or associated piping) must not be lifted and transported together with the measuring system without the use of additional support from the lifting gear.
- Never attach lifting gear to the signal processing unit or its mounting bracket and avoid contact between these parts and the lifting gear.

1.8 **Environmental information and instructions for disposal**

The FLOWSIC600 components are easily disassembled and do not contain toxic, radioactive or any other environmentally hazardous materials. The instrument consists primarily of steel, stainless steel, plastic and aluminium, and consequently there are few restrictions for disposal, except for the printed circuit boards, which must be disposed of as electronic scrap.

FLWSIC600

2 Product Description

- System components
- Operating states, meter states and signal output
- Self-Diagnosis with User Warnings
- Data Handling in the FLWSIC600
- FLOWgate™

2.1 **System components**

The FLOWSIC600 measuring system consists of the following hardware components:

- Meter body
- Ultrasonic transducers
- Signal processing unit (SPU)

The FLOWgate™ software is the user interface used to facilitate configuration and diagnosis (→ pg. 25, 2.5).

Figure 1 FLOWSIC600

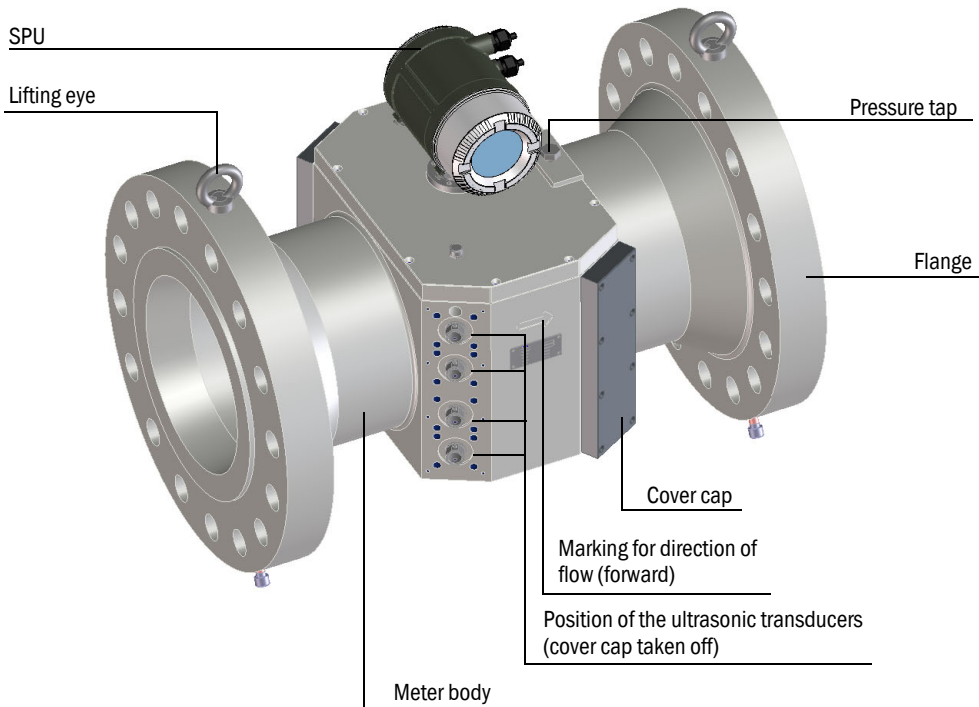

2.1.1 **Meter body**

The meter body consists of a mid section for mounting the ultrasonic transducers, with flanges on either end. The meter body is made of a single-piece casting or forging, which is machined on precision equipment to ensure high reproducibility of the geometric parameters.

The internal diameter, design of the sealing surface, and standard dimensions of the flanges are in accordance with the specifications in the key code. The meter body material is chosen to suit customer requirements. Standard meter bodies are available in carbon steel, low temperature carbon steel and stainless steel.

The meter bodies can be delivered in several nominal sizes (→ pg. 106, 7.1.4).

2.1.2 **Ultrasonic transducers**

The FLOWSIC600 ultrasonic transducers are optimized to suit your application requirements. The high quality of the transducer design provides the basis for accurate and highly stable propagation time measurements with nanosecond precision. These transducers are of an intrinsically safe design ("ia", with Equipment Protection Level Ga).

2.1.3 **Signal processing unit**

The Signal processing unit (SPU) contains all the electrical and electronic components for controlling the ultrasonic transducers. It generates transmission signals and analyzes the received signals to calculate the measuring values. The SPU also contains several interfaces for communication with a PC or standardized process control system.

The volume counters, log books (errors, warnings, parameter changes) and datalogs are stored in non-volatile data memory (FRAM) together with a time stamp (Logbooks → pg. 136, 7.5.) On system restart, the counter readings that were last saved are restored as the start values for the volume counters. The FRAM backup provides an unlimited number of writing cycles and protects the saved data for a minimum of 10 years.

The SPU is equipped with a front panel containing a two-line LCD to display current measured values, diagnostics and logbook information (→ Figure 2). An LED display is optionally available. The values to be displayed can be selected using a magnetic pen without removal of the window cover .

Figure 2 FLOWSIC600 front panel LCD

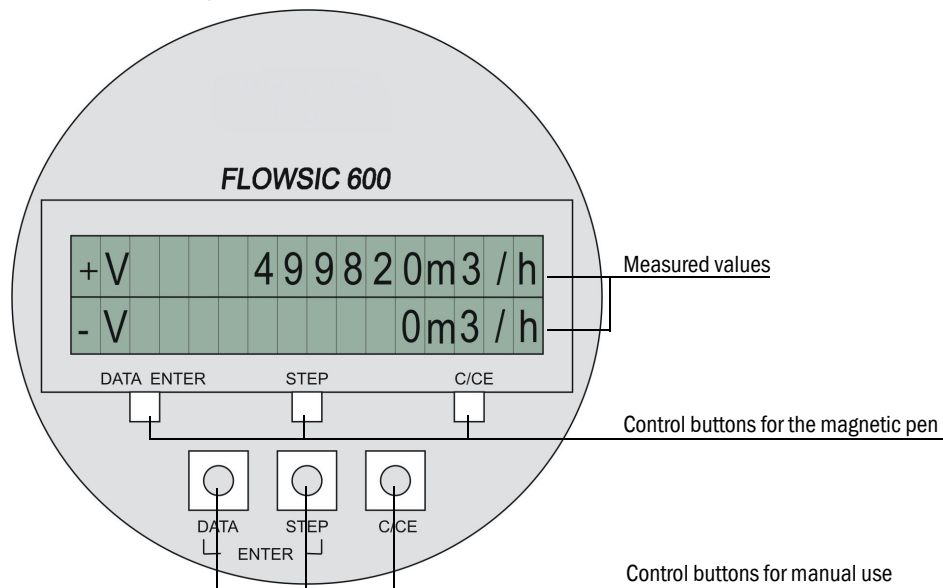

The power supply and interface terminals are located on the back of the SPU in a separate terminal section of the enclosure (→ pg. 42, 3.4.4).

The electronics are mounted in the SPU enclosure certified to EN / IEC 60079-1 with protection type "d" (flameproof enclosure). The transducer circuits are of an intrinsically safe design ("ia", with Equipment Protection Level Ga).

2.2 **Operating modes, meter states and signal output**

The FLOWSIC600 has two operating modes (→ pg. 16, 2.2.1):

- Operation
- Configuration Mode

In Operation Mode, the meter can have the following meter states (→ pg. 17, 2.2.2):

- Measurement valid
- Check request
- Data invalid

2.2.1 **Operation mode and configuration mode**

The meter can be operated by the user in two modes: Operation Mode or Configuration Mode.

Operation Mode

In Operation Mode, the meter runs in one of the three aforementioned meter states, depending on the measuring conditions.

Configuration Mode

The Configuration Mode is used to modify parameters that directly influence the measurement and to test the system and output signals. Configuration Mode forces the meter into the meter status "Data invalid" and the digital output "Measurement valid" is deactivated. Invalid measured values may be produced. The system continues operation using the current sample rate and executes all calculations as in the Operation Mode. Frequency output and analog output may represent test values and do thus not necessarily indicate measured values. Any parameter modifications are applied immediately to the running calculations with the following exception: changes of the sample rate or of the configuration of the serial interface are applied after the meter is switched to Operation Mode.



If the meter is in Configuration Mode and there have been no activities either on the LCD display or via FLOWgate™ for more than 15 minutes, the meter automatically switches to Operation Mode.

2.2.2 **Meter states**

2.2.2.1 **Green status: Measurement valid**

The meter status "Measurement" is the standard meter status of the FLOWSIC600. Frequency outputs and current output are updated cyclically and indicate the actual volume and volume flow rate. In addition, the analog signal can indicate the actual flow rate, corrected volumetric flow rate, SOS (speed of sound) or VOG (velocity of gas). The digital output "Direction of flow" is updated in accordance with the direction of the volumetric flow. The digital output "Measurement valid" (active) represents the status of the measurement. Positive (forward) and negative (reverse) volumetric flow rates are integrated and saved in separate internal memory sections.

The MODBUS interface allows the query of all parameters and signals at any time without interfering with the function of the system.

Each measurement initiated by the system controller includes one full transit time measurement with, and one against the direction of flow on each path. The result of each measurement is written to a mean value memory to be used in further calculations. The size of this memory block and thus the device response delay can be modified through the parameter in register #3502 "AvgBlockSize". If no result can be calculated due to poor signal quality, this measurement is registered as an invalid attempt in the mean value memory. The mean value is formed in a variable averaging process including all valid measured values in the memory.

If the number of invalid measurements on a path exceeds a predefined limit (Reg. #3514 „Performance“), the measuring system activates the meter status "Check request".

2.2.2.2 **Yellow status: Check request**

This meter status becomes active if one measuring path has failed and the adaptive path failure compensation has been activated. The multi-path FLOWSIC600 system is able to compensate for this failure. Measurement is continued with reduced accuracy and the volume is still counted in the volume counters. If a path fails while the path failure compensation is not active, the measuring system will activate the "Data invalid" status.

Moreover the meter status "Check request" becomes active when the system alarms 2002 ("No HART communication to temperature transmitter"), 2003 ("No HART communication to pressure transmitter"), or 2004 ("Maximum pulse output frequency exceeded") become active (table → pg. 137, 7.5.1).

2.2.2.3 **Red status: Data invalid**

If the quality of received signals is deficient in one or more measuring paths or the logbook is full or the measured value is out of the calibration range, the SPU must mark the measured value invalid and activate the meter status "Data invalid". The measured volume is counted in the error volume counter. However, the SPU will cyclically attempt to re-establish valid measurements. As soon as the signal quality and number of valid measurements meet the required criteria, the SPU will automatically change back to the "Measurement valid" or "Check request" status.

2.2.3 Output of pulse signals and status information

	<p>NOTICE: TYPE APPROVAL</p> <p>Pulse output signals can be customized as shown in the following table.</p>
---	--

Table 1 Pulse output

Output signal / LCD / port		Signal behavior			
		Measurement status	Check request status	Configuration Mode	Data invalid*
Pulse output signals	Inverted with error signal **				
	Phase shift 90° ***	Positive flow rate			
		Negative flow rate			
	Separate outputs for reach direction	Positive flow rate			
		Negative flow rate			
Single pulse output ***					

* The meter can be configured to output a fixed frequency if the meter has the status "Data invalid". The frequency to be output in this case can be configured (0-6 kHz) in Reg. #3034 "ErrorFreq".

** Default setting on delivery.

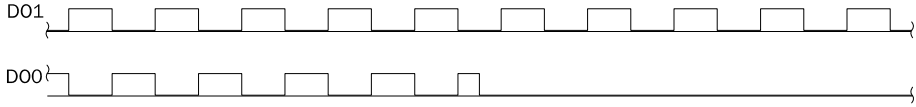
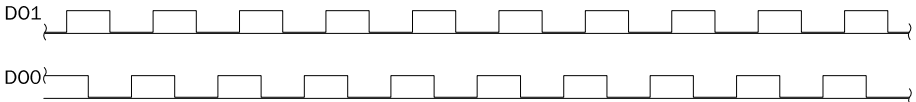
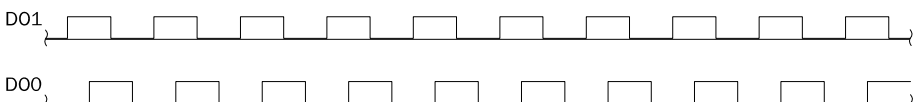
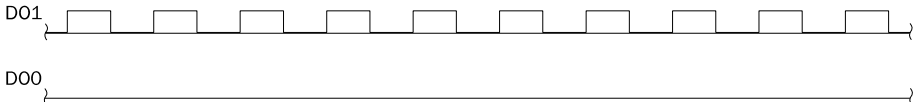
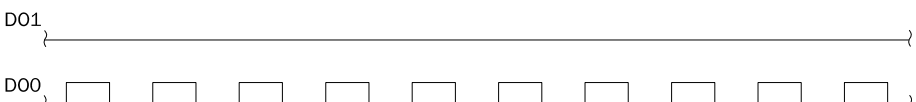
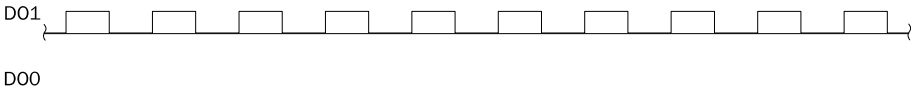
*** Optional setting on customer request.

The default setting for "Check request", "Configuration" and "Data invalid" is "normally closed".

Table 2 Status output

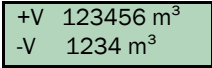
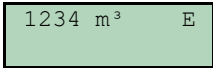
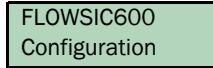
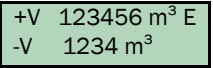
Output signal / LCD / port	Signal behavior			
	Measurement status	Check request status	Configuration Mode	Data invalid
"Check request" Status signal	Status "active / inactive" * Measurement valid	Status "active / inactive" * Compensation of path failure	"undefined"	"undefined"
"Direction of flow" Status signal	Status "active / inactive" * Positive or negative direction of flow	Status "active / inactive" * Positive or negative direction of flow	"undefined"	"undefined"
"Warning"	Status "active / inactive" *	Status "active / inactive" *	"undefined"	"undefined"
LCD display		 Display flashing		 Display flashing
Serial port RS485	<ul style="list-style-type: none"> ● Measured value, diagnosis information and parameters ● Measuring data logging, diagnosis and configuration through the FLOWgate™ software ● Connection with external process control equipment through implemented MODBUS protocol (data polling) 			

*The "active" or "inactive" state can be assigned to the electric switch status "normally open" or "normally closed" by configuration in the FLOWgate™ software (adjust settings for Reg. #5101 on the "Parameters" page.).

The LCD display can display measured values, parameters, messages and other information.

A flashing letter in the upper right corner of the LCD display indicates that a logbook contains unacknowledged logbook entries. Depending on the type of entry this will be:

- "I" for Information
- "W" for Warning
- "E" for Error

After acknowledging all new entries, the letter stops flashing. For details see → pg. 88, 5.4.1.

2.3 Self-diagnosis with User Warnings

During normal operation, the ratios of sound and path velocities, amplification values, performance, and signal-to-noise ratios are continuously monitored. If these values exceed set limits (customized User Warning limits), a warning signal will be generated. This allows immediate measures to be taken to address a problem which could potentially impact measurement quality. A message in the Warning Logbook documents the time of the event and the specific User Warning limit which was exceeded.

- The "Warning" signal does not affect the functionality of the meter.
- All User Warning parameters - except for the parameter 'Min. VOG for warnings' - can be configured in the User Access Level "Operator" and without switching the meter to the Configuration Mode.

A User Warning becomes active only if a User Warning limit has been continuously exceeded for a certain time (specified in the parameter "Warning duration and averaging for warnings" in the System/Profile tab of User Warnings).

During commissioning or operation, the User Warning limits can be adapted and activated or deactivated in the "User Warnings" window in FLOWgate™ to suit individual application requirements (→ pg. 72, 4.7.1).

Figure 3 Diagnostics menu

The screenshot shows the 'DIAGNOSTICS' menu in the FLOWgate™ interface. At the top, there is a status bar with service information (7/15/2024 3:13:16 PM) and various icons. Below this, a row of numerical data is displayed: Q [acm/h] 16.6, Q_b [scm/h] 16.35, P [bar(a)] 1, T [°C] 20, VOG [m/s] 1.08, and SOS [m/s] 347.51. The main area is divided into two tables: 'System Warnings' and 'Precondition'. The 'System Warnings' table has columns for Unit, User Limit, Live Value, and Active. The 'Precondition' table has columns for Unit, User Limit, and Live Value. A right-hand sidebar contains navigation options: OVERVIEW, FAVORITES, DIAGNOSTICS (highlighted), ARCHIVE MANAGEMENT, LOGBOOK MANAGEMENT, FIELD SETUP, PARAMETER MODIFICATION, and SERVICE.

System Warnings	Unit	User Limit	Live Value	Active
Profile Factor Valid Value		1.17	0.610	<input type="checkbox"/>
Profile Factor Range	%	5		<input type="checkbox"/>
Symmetry Valid Value		1	0.926	<input type="checkbox"/>
Symmetry Range	%	5		<input type="checkbox"/>
Theoretical SOS Deviation	%	0.3	-	<input type="checkbox"/>
VOG Limit	m/s	43	1.08	<input type="checkbox"/>
Input Voltage Warning	mV	11000	21400	<input type="checkbox"/>
Configuration Mode				<input type="checkbox"/>
Logbook unackn. Entries				<input type="checkbox"/>
Logbook Full				<input type="checkbox"/>

Precondition	Unit	User Limit	Live Value
Warning/Averaging Duration	s	30	
Min. VOG for Warnings	m/s	0	1.08
SOS Profile Rising	%/s	0	0

2.4 **Data handling in the FLOWSIC600**

2.4.1 **Integrated volume counters**

The FLOWSIC600 is equipped with integrated volume counters which can be displayed both on the LCD display and in FLOWgate™.

Integrated volume counters

Volume counter	Abbreviation
Volume at flowing conditions (forward)	+ Vf
Volume at flowing conditions (reverse)	- Vf
Error volume at flowing conditions (forward)	+ Ef
Error volume at flowing conditions (reverse)	- Ef
Total volume at flowing conditions (forward)	+ Vo
Total volume at flowing conditions (reverse)	- Vo
Total volume at flowing conditions (all)	Vo

Last hour/day registers

Volume counter	Abbreviation
Forward volume of last hour	Last hour forw.
Reverse volume of last hour	Last hour rev.
Forward volume of last day	Last day forw.
Reverse volume of last day	Last day rev.

Additional counters in meters with integrated Electronic Volume Corrector (EVC)

Volume counter	Abbreviation
Volume at base conditions (forward)	+ Vb
Volume at base conditions (reverse)	- Vb
Error volume at base conditions (forward)	+ Eb
Error volume at base conditions (reverse)	- Eb

Mass counters

Mass counter	Abbreviation
Mass counter (forward)	+ M
Mass counter (reverse)	- M
Mass total (forward)	M+
Mass total (reverse)	M-
Error Mass (forward)	Me+
Error mass (reverse)	Me-

2.4.2 Logbooks

Important system events are stored in three logbooks in the SPU memory of the meter.

Each logbook entry consists of a running index number, the event, a time stamp and the acknowledgement status. Entries in Custody logbook [1] and Warning logbook [2] also include the volume counter readings valid at that time. The events are logged continuously in order of occurrence into one of the three logbooks:

- Logbook 1 (Custody logbook [1], max. 1000 entries)
- Logbook 2 (Warning logbook [2], max. 500 entries)
- Logbook 3 (Parameter logbook [3], max. 250 entries)

Every logbook has its own index counter. Logbook entries are classified on the LCD display according to the event type.

Event types in logbooks

Display	Event type
E	Error
W	Warning
I	Information

A list of possible logbook entries can be found in the table 'Overview of event entries' in the Appendix, see → pg. 137, 7.5.1.

Logbook overflow

All logbooks are per default configured to be overflowing. This means the index number continues increasing, and after the logbook has reached its maximum number of entries, each new entry overwrites the oldest entry.



If the logbook overflows, the oldest data will be lost. Regularly saving the logbook entries to the database via FLOWgate™ (→ pg. 88, 5.4.1) and deletion of entries in the meter itself prevents data loss. If entries are deleted via FLOWgate™, the logbook index counter on the meter is reset.

Index counter overflow

The index number displayed in the LCD display runs up to 9999 and then overflows. In case of an index overflow, all logbook entries are deleted and all logbook index counters reset.

Acknowledging entries

Each entry can be acknowledged manually on the LCD display (as well as in FLOWgate™ (→ pg. 89, 5.4.1.2)). It is possible to acknowledge individual entries or all entries at once.

2.4.3 **DataLogs¹**

For firmware version 3.4.03 and higher, the FLOWSIC600 provides two DataLogs (Hourly Log and Daily Log). They save averaged measured values and are stored in the SPU's non-volatile memory (FRAM). All data can be downloaded and exported to Excel files with FLOWgate™ (→ pg. 90, 5.4.2.1.).

 The following sections describe the default configuration of the DataLogs. The DataLogs can be configured to best suit your application → pg. 74, 4.7.2.2.

2.4.3.1 **Hourly Log**

The Hourly Log logs hourly diagnostic values by default for the forward flow. As long as the flow is valid and the VOG is above Vmin all diagnostic and flow values are averaged over one hour and saved every full hour. The Hourly Log stores these values for more than a month (38 days) by default. They are then overwritten with new values.

2.4.3.2 **Daily Log**

The Daily Log logs the daily volume counter values by default for the forward flow. All flow values are averaged over one day and saved at the (configurable) Accounting Hour. The Daily Log stores these values for approximately 2 years by default (1 year and 361 days). They are then overwritten with new values.

DataLog Storage Cycle

Hourly Log and Daily Log can be configured to save entries in a storage cycle of: 3 min, 5 min, 15 min, 30 min, 1 hour, 12 hours or 24 hours.

If a DataLog is set to a Storage cycle of 12 or 24 hours, the accounting hour takes effect.

2.4.3.3 **DataLog storage behavior**

Hourly Log and Daily Log can be configured for the following storage behavior:

- Overflow (Default)
- Stopping

 **Storage Behavior "Stopping"**
If a DataLog is configured with the storage behavior "Stopping", a warning will be shown in the Meter Status Table when the DataLog is full. See → pg. 85, 5.2.3.

2.4.3.4 **Types of datasets stored in the DataLogs**

Hourly Log and Daily Log can be configured to store one of the following type of dataset:

- Diagnostic values
- Volume counter
- Std. volume counter
- Mass flow counter

¹ This feature may be deactivated. Please contact your Endress+Hauser representative.

2.4.4 **Diagnostics Comparison Log¹**

The Diagnostics Comparison Log provides a comparison between current diagnostic values (current fingerprint) and those of a reference time (reference fingerprint, for example, at time of commissioning). Since the diagnostic values are velocity-dependent, it is necessary to use a velocity-adaptive comparison. Five gas velocity range classes are calculated from the velocity range of the meter. The current diagnosis values are stored in Current Classes 1 to 5, while the reference values are stored in Reference Classes 1 to 5.

Reference values are collected after the meter has been commissioned or after the classes have been cleared. Reference values are stored in the Reference Classes 1 to 5. If a Reference Class is filled with an entry, the next valid entry is stored into the same velocity range but in the corresponding Current Class (e.g. if Reference Class is filled, the next value from within this velocity range will be stored in Current Class 1). During operation, the Current Classes are continually overwritten with new entries. The Reference Classes stay unchanged until they are manually cleared.

Per default the Diagnostics Comparison Log operates bidirectional, saving separate data for both flow directions. The values are stored in the gas velocity classes 1 to 5, depending on the gas velocity.

Figure 4 Diagnostics Comparison Log

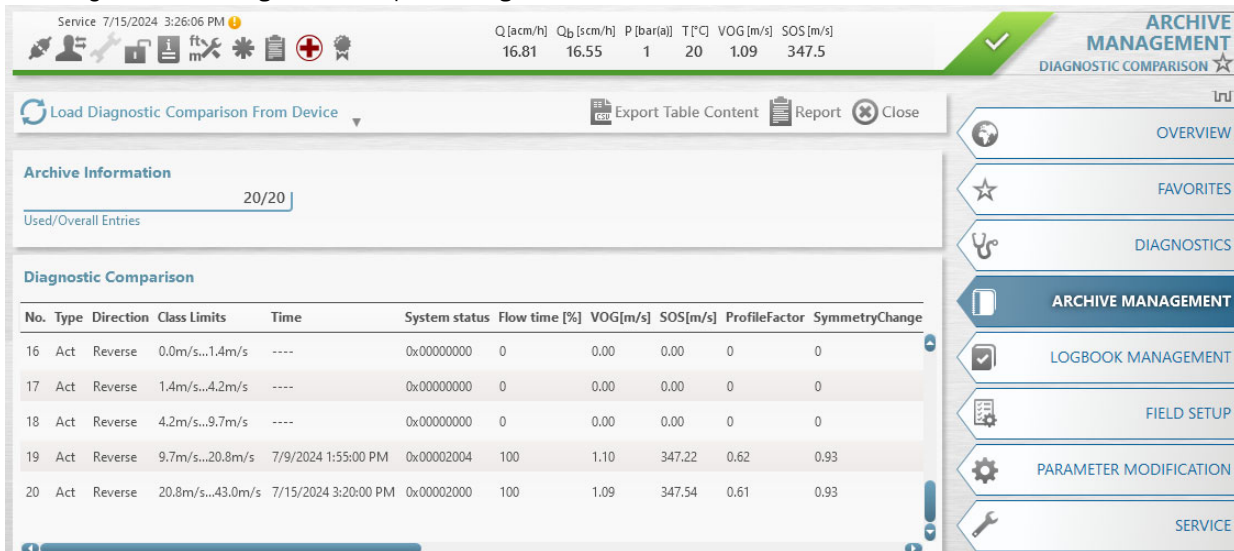

1 This feature may be deactivated. Please contact your Endress+Hauser representative.

2.5 **FLOWgate™**

Most data provided by the FLOWSIC600 (like readings, logbook entries and parameters) can be accessed via the LCD display of the meter. However, the FLOWgate™ software provides a more user friendly access to diagnostic, configuration and measurement data of the flow meter.

2.5.1 **System requirements**

- Microsoft Windows 7/8/10/11
- Min. 1 GHz CPU
- Min. 512 MB RAM
- About 100 MB free disk capacity (without .NET framework)
- USB or serial interface
- Recommended minimum screen resolution: 1024 x 768 pixels, optimum screen resolution 1368 x 768 pixels
- Microsoft .NET framework 4.6

Compatibility

FLOWgate™ can be used together with the FLOWSIC600 as from firmware version: 3.1.00 as well as hardware version: 2. The availability of the software features depends on the firmware version of the connected FLOWSIC600.

Installation

The software can be downloaded free of charge from the website www.endress.com/downloads (search “FLOWgate”).

After downloading the software, execute the Installer exe and follow the instructions of the installation Wizard.

 Administrator rights are required for installation of FLOWgate™. Ensure that FLOWgate™ users have write access for the specified database path.

2.5.2 Overview



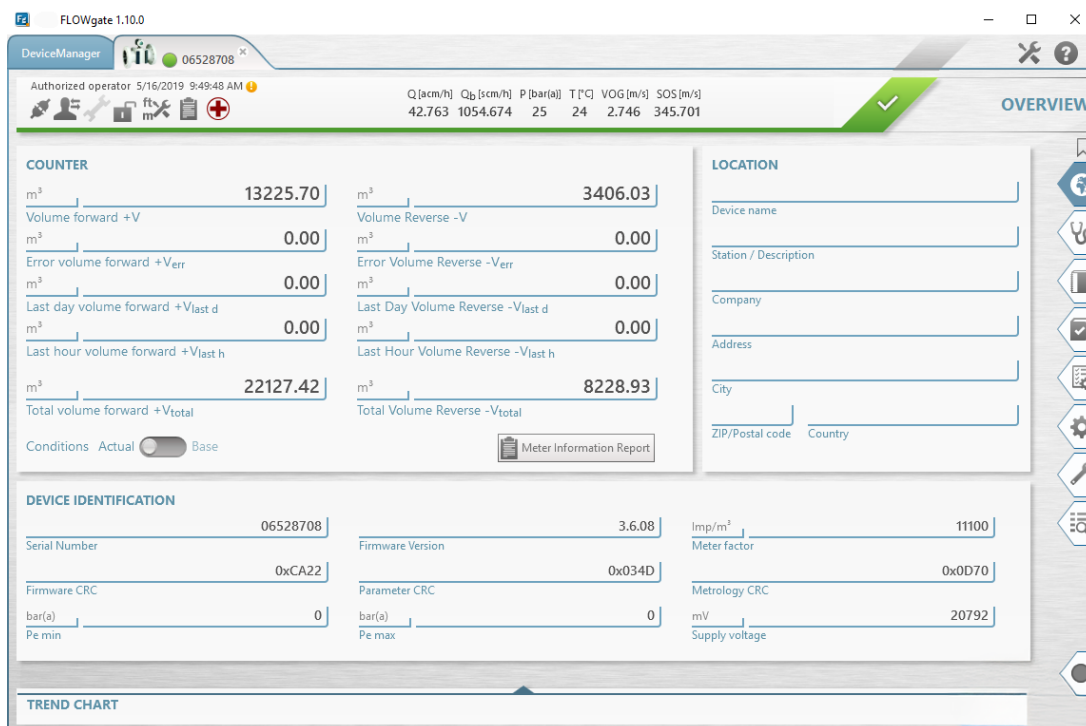

Software functions

- Measured values overview
- Diagnosis data
- Logbook and archive management
- Commissioning
- Parameter modification
- Session browser
- Calibration

Figure 5 OverviewFLOWgate™ operating software



Software features

Main bar	Description
Fast access menu	Access to often used functions e.g.: <ul style="list-style-type: none"> - Connect/disconnect - Switch user level - Record diagnostic session - Register quick access
Main readings	Main readings and data of measurement: <ul style="list-style-type: none"> - Flow actual and base flow - Pressure - Temperature - Vog (velocity of gas) - SoS (speed of sound)
Meter status	 green: no warnings/errors, measurement valid  yellow: active warnings, measurement still valid  red: active errors, measurement invalid  grey: offline
Main menu	Description
Overview	Overview of higher level meter information: Counter readings, identification and location of meter and display of readings (e.g. flow rate) in trend chart.
Favorites	Fast access to choosen submenus. Set a favorite by using the star symbol over main menu in a submenu.
Diagnostics -> Status diagnostics	Status overview to get fast overview about summary status and current status.
Diagnostics ->Meter Values	Detailed diagnostic page with graphs for velocity of gas, speed of sound (SOS), path performance, AGC, signal-to-noise-ratio (SNR), turbulence, profile symmetry and user selectable readings (e.g. flow rate). Summary of device status.
Diagnostics ->Warnings	Overview of system and path warnings. User warning limits can be set and activated.
Diagnostics ->Signal view	Access to path diagnosis and graphs of received signals.
Diagnostics ->SoS Calculator	A theoretical SOS can be calculated for a specific gas composition.
Logbook Management	Access to meter logbooks and logbook entries saved to meter database.
Archive Management	Access to meter archive and archives entries saved to meter database.
Commissioning	Commissioning wizard guides through the necessary steps to put the device into service and can generate reports.
Parameter Modification	Access to all meter parameters. Assistant for comparing current parameter settings with previous ones.
Service	Functions and wizards that are helpful for service like the "Transducer Exchange" wizard
Session Browser	Overview of all created device sessions. Import and export of sessions and the including data.
Calibration	The calibration wizard guides the user through the calibration procedure with automated processes to write the information to the meter and generate reports.

FLOWSIC600

3 Installation

General notes

Installation

Mechanical installation

Electrical installation

3.1 General notes

3.1.1 Delivery

The FLOWsic600 is delivered in a pre-assembled condition in a sturdy package. When unpacking the device, check for possible damage in transit. Pay particular attention to the interior of the meter body, any visible transducer components and the sealing surfaces on the flanges. Any damage must be documented and reported to the manufacturer immediately.

Also check the shipment to ensure all components are included. The standard meter shipment is comprised of:

- ▶ FLOWsic600 measuring system (meter body with signal-processing unit and transducers)
- ▶ FLOWgate™ operation, configuration and diagnosis software
- ▶ Operating Instructions,
- ▶ Manufacturer Data Report (MDR)



NOTICE:

To guarantee safe and reliable operation of the measuring equipment, make sure the actual site conditions match the information provided on the labels on the meter body and SPU (see Figure 6).

Figure 6

FLAWSIC600 labels and marks

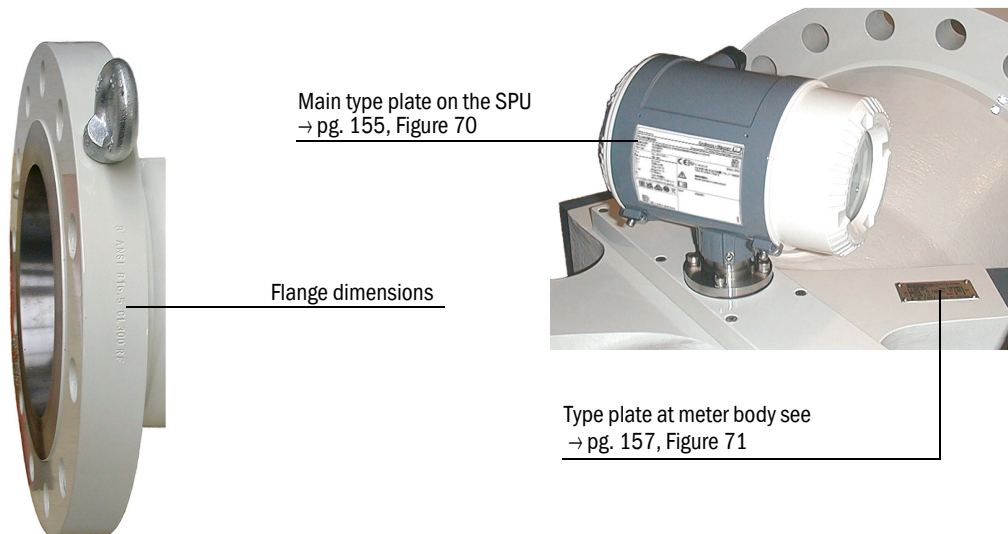

3.1.2

Transport and storage

	<p>WARNING: Only use lifting gear and equipment (e.g. lifting straps) which is suitable for the weight to be lifted. Max. load information can be found on the type plate of the lifting gear. It is strongly recommended to use only the eye bolts when lifting the meter by itself. To lift the FLOWSIC600 please pay attention to Figure 7.</p>
---	---

During FLOWSIC600 transport and storage operations, make sure that:

- ▶ The meter is firmly secured at all times
- ▶ Measures are taken to avoid mechanical damage
- ▶ Humidity and ambient temperature are within specified limits (→ pg. 107, Table 7).

If the device is to be stored outside for more than one day, sealing surfaces of the flanges and the interior of the meter body must be protected from corrosion, e.g. with Anticorit spray (not required for stainless steel meter bodies). The same measure shall be taken if the meter is to be stored in dry condition, but for more than a week.

	<p>NOTICE: Due to natural temperature fluctuation in the course of a day, or if the meter is transported to a place with different temperature and humidity conditions, moisture may condense on any material. Carbon steel surfaces may corrode if left unprotected.</p>
---	--

Figure 7

Lifting requirements

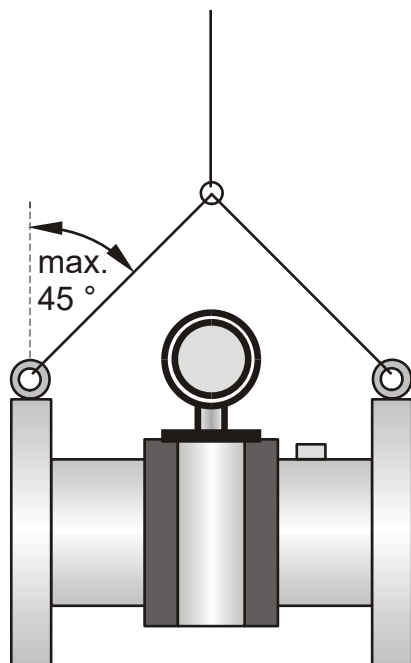

3.2 Installation

Generally, the installation arrangement is specified during the project planning phase, before installation of the system. Nominal size, material and type of flange should therefore be in accordance with the design of the measurement facility. It is particularly important that the meter inlet and outlet is of the same internal diameter as the adjacent piping.

Fastening bolts, nuts and flange seals used must be suited to the operational conditions, and comply with legal regulations and relevant standards.

3.2.1 Measuring location

General requirements:

- The FLOWSIC600 can be installed in customary straight inlet and outlet pipes. The adjacent pipes must have the same nominal size as the meter body. The max. permitted difference of the internal diameter of the inlet pipe from that of the meter body is 3%. Any welding beads and burs on the flanges of the inlet pipe shall be removed.
- The meter body may be installed in a horizontal or vertical position. In case of horizontal installation, the meter body shall be aligned so that the planes formed by the measuring paths are in a horizontal position. This minimizes dirt in the pipeline from entering the transducer ports. Vertical installation is only possible if the measuring system is used for dry, non-condensing gases. The gas flow must be free from any foreign material, dust and liquids. Otherwise, filters and traps shall be used.
- Do not mount equipment or fittings which may adversely affect the gas flow directly upstream the FLOWSIC600.
- Seals at the flange connections between meter body and pipeline must not protrude into the pipeline. Any protrusion into the flowing gas stream may change the flow profile and thus the measuring accuracy may be adversely affected.
- Pressure transmitter shall be connected to the pressure tap provided (→ pg. 14, Figure 1). The pressure tap can be a 1/8, 1/4 or 1/2 inch NPT (female) port, depending on meter size and customer requirements.
- For the leak-proof connection on the pressure line, a suitable thread sealing agent (e.g. PTFE tape) must be used when the pressure connection adapter is screwed in. After Installation and Commissioning the leak-tightness must be checked. All leaks must be repaired. Temperature probes shall be arranged as shown in → Figure 8 and → Figure 9.

3.2.2 Installation configurations

The choice of the installation configuration (see → Figure 8 and → Figure 9) depends on type and extent of the flow disturbance at the installation position.

Type of disturbance (distance upstream < 20 DN)	Possible installation configuration
None	Configuration 1 or 2
Elbow, reducer	
Double elbow out of plane, T piece	
Gas pressure controller with/ without noise abatement trim	Configuration 2
Diffuser	
Diffuser with swirling flow	

+i When configuration 2 (with flow conditioner) is used, the velocity of gas must not exceed 40 m/s (131 ft/s) in the pipe.

Unidirectional use

Figure 8 FLOWSIC600 installation in the pipeline for unidirectional use

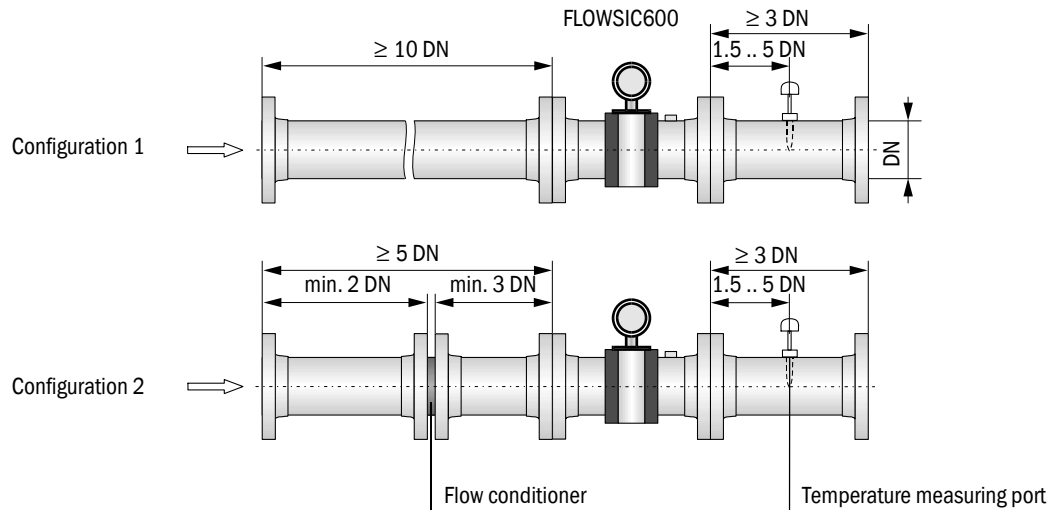

+i Typically, 2-paths modification requires 20 DN inlet pipe and 5 DN outlet pipe.

Bidirectional use

Two straight pipes are to be installed in the inlet and outlet sections if the meter is to be used bidirectionally. The temperature measuring point is to be located downstream of the FLOWSIC600, seen in the direction of predominant use. The temperature measuring point must not be installed more than 8 DN from the meter.

Figure 9

FLWSIC600 installation in the pipeline for bidirectional use

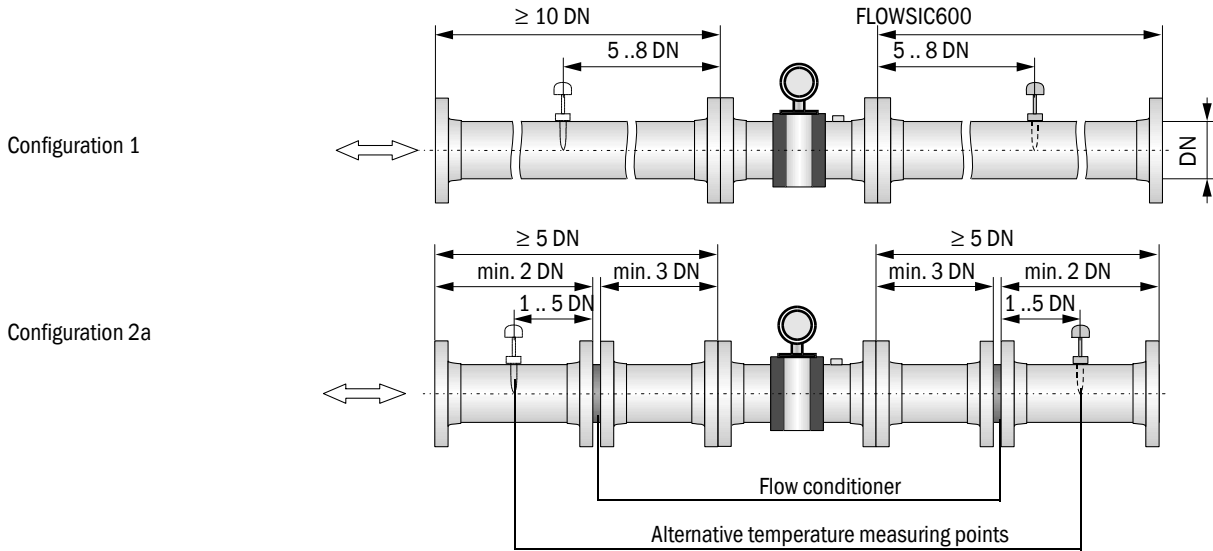

2-paths modification requires 20 DN inlet pipe and 20 DN outlet pipe.

3.3 **Mechanical installation**

Work on the pipelines to prepare for the installation of the gas flow meter is not included in the scope of delivery.

It is recommended to use the following tools, equipment and supplies for installation of the FLOWSIC600:

- Lifting gear or fork lift (with sufficient capacity to lift meter or meter-piping assembly)
- Box wrench with size suitable for flange installation
- Thread seal (e.g. PTFE tape) and flange gaskets
- Bolt lubricant,
- Leak detection spray



WARNING: DANGER

- Always observe the general safety regulations and safety instructions given in Section 1 when carrying out any installation work.
- The FLOWSIC600 must only be mounted on depressurized and vented pipelines.
- Take all necessary precautions to avoid local or plant-specific dangers.

3.3.1 **Choosing flanges, seals and other parts**

Use pipeline flanges, bolts, nuts, and seals that withstand the maximum operational pressure and temperature, as well as ambient and operational conditions (external and internal corrosion) for the flange connections. For installation lengths and flange dimensions, see MDR.



WARNING: DANGER

- Always strictly observe the safety instructions for the installation of pressure equipment including the connection of several pressure components set forth in the local or national relations and standards or Pressure Equipment Directive 2014/68/EU.
- Installation staff must be familiar with the directives and standards applicable for pipeline construction.

3.3.2 **Mounting the FLOWSIC600 in the piping**

An arrow on the meter body indicates the main direction of flow. It is recommended to install the FLOWSIC600 as indicated by this arrow if the meter is to be used for unidirectional flow applications. If the meter is to be used in the bidirectional mode, the arrow indicates the positive direction of flow.

Installation work to be carried out

	<p>WARNING:</p> <ul style="list-style-type: none"> ● The lifting eyes are designed for transporting the meter only. Do not lift the FLOWSIC600 using these eyes when additional loads (such as blind covers, filling for pressure tests or piping) are attached (also see → pg. 31, 3.1.2) ● Never attach lifting gear to the signal processing unit or its mounting bracket and avoid contact between these parts and the lifting gear. ● The FLOWSIC600 must not turn over or start to swing while being transported. Flange sealing surfaces, SPU housing and transducer cover caps may be damaged when the lifting gear is not attached properly. ● Take suitable measures to prevent damage to the meter when carrying out any other work (welding, painting) near the FLOWSIC600.
---	--

- ▶ Position the FLOWSIC600 at the desired location of the pipeline using the lifting gear. Only use the lifting eyes provided to lift and transport the device. If lifting straps are used, wrap them around the meter body.
- ▶ Check for correct seating and alignment of the flange gasket after installing the flange bolts, but prior to tightening.
- ▶ Align the FLOWSIC600 such that the offsets between inlet pipe, meter body and outlet pipe are minimized.
- ▶ Insert the remaining fastening bolts and tighten the nuts cross-wise. The tightening torque applied must not be lower than specified in the project planning.
- ▶ Mount the pressure sensing line between pressure tap and pressure transmitter.
- ▶ Fill the pipeline and check the installed FLOWSIC600 and piping connections for leaks.

	<p>NOTICE: Observe allowed pressure change</p> <ul style="list-style-type: none"> ▶ The pressure change within the measuring section must not exceed 0.5 MPa/min in order to protect transducers and seals.
---	---

	<p>It is recommended to perform a leak test in accordance with the relevant regulations and standards after completion of the mechanical installation.</p>
---	--

3.3.3 **SPU alignment**

The signal processing unit (SPU) can be turned so that the display can be easily read and that cable routing is facilitated (see → Figure 10). A stop on the housing prevents the SPU from being turned by more than 330° to prevent damage to the cables that come from the meter body.

Figure 10 Positioning the SPU.

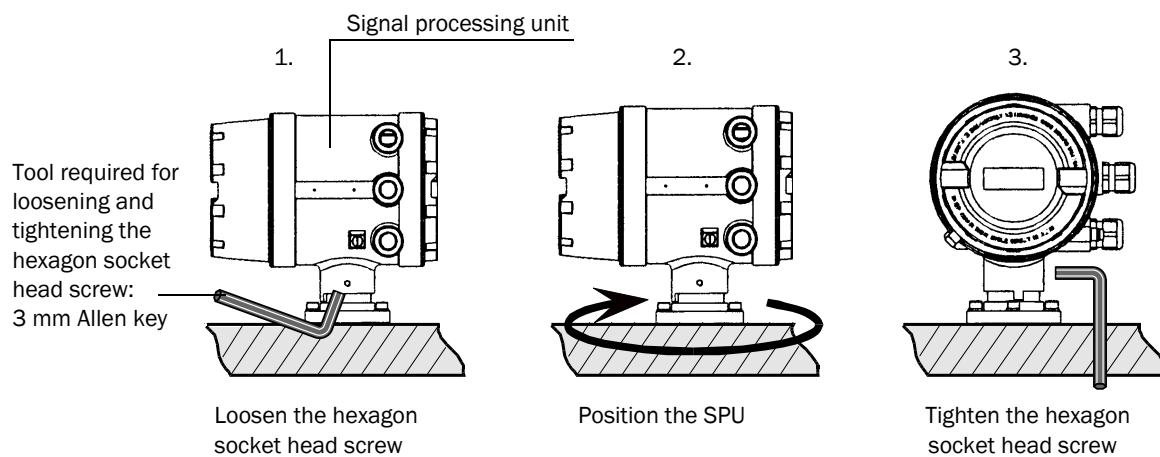

NOTICE: Do not forget to tighten the hexagon socket head screw after positioning the SPU.

3.4 Electrical installation

3.4.1 General information

Prerequisites

Wiring work (routing and connecting the power supply and signal cables), which is necessary when installing the FLOWSIC600, is not included in the scope of delivery. The mechanical installation described in Section →3.3 must be completed first. Comply with the minimum cable specification requirements set out in Section →3.4.2.

Cable routing

- ▶ Keep cables in conduits or laid on cable trays to provide protection from mechanical damage.
- ▶ Observe the permitted bending radiuses (generally, min. six times the cable diameter for multi-conductor cables).
- ▶ Keep all connections outside of conduits as short as possible.



WARNING: DANGER

- ▶ Always observe the general safety regulations and safety instructions given in Section 1 when carrying out any installation work.
- ▶ Installation work shall only be carried out by trained staff and in accordance with the relevant regulations issued by the operating company.
- ▶ Take all necessary precautions to avoid local or plant-specific dangers.

General connection of the FLOWSIC600

Figure 11

FLAWSIC600 connection diagram

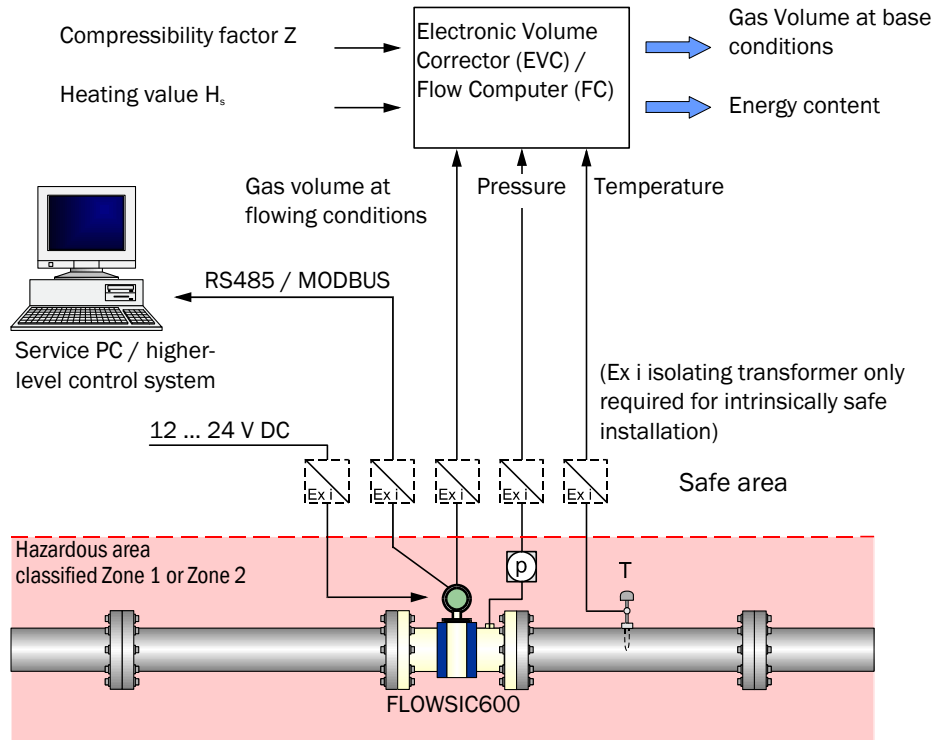

3.4.2

Cable specifications**WARNING:**

The cables must fulfil the requirements for use in hazardous areas (e.g. set forth in EN /IEC 60079-14 or other relevant standards).

Power supply 12 ... 28.8 V DC

	Specification	Notes
Type of cable	Two conductors	Connect shielding (if present) to ground terminal
Min./ max. cross-sectional area	0.5 mm ² / 2.5 mm ² (20 - 12 AWG)	
Maximum cable length	Depending on loop resistance; Minimum input voltage on the FLOW-SIC600 must be 12 V DC.	Peak current 150 mA
Cable diameter	6 ... 12 mm (1/4 to 1/2 inch)	Fixing range of the cable glands

Digital output / current output

	Specification	Notes
Type of cable	Twisted pair, shielded	Connect shielding at other end to ground terminal
Min./ max. cross-sectional area	2 x 0.5/1 mm ² (2 x 20-18 AWG)	Do not connect unused conductor pairs and prevent them from accidental short-circuit
Maximum cable length	Loop resistance ≤ 250 Ω	
Cable diameter	6 ... 12 mm (1/4 to 1/2 inch)	Fixing range of the cable glands

Serial port (RS485)

	Specification	Notes
Type of cable	Twisted pair, shielded, impedance approx. 100...150Ω low cable capacitance: ≤ 100 pF/m	Connect shielding at other end to ground terminal
Min./ max. cross-sectional area	2 x 0.5/1 mm ² (2 x 20-18 AWG)	
Maximum cable length	300 m at 0.5 mm ² (1600 ft for 20 AWG) 500 m at 0,75 mm ² (3300 ft for 20 AWG)	Do not connect unused conductor pairs and prevent them from accidental short-circuit
Cable diameter	6 ... 12 mm (1/4 to 1/2 inch)	Fixing range of the cable glands

**NOTICE:**

Only the lower fault current may be used with an internally fed analog output and use of HART communication.

3.4.3

Checking the cable loops

Check the cable loops to verify that the cables are connected correctly. Proceed as follows:

- ▶ Disconnect both ends of the cable of the loop to be tested. This is to prevent connected devices from interfering with the measurement.
- ▶ Test the entire cable loop between SPU and terminal device by measuring the loop resistance.
- ▶ If you want to test the insulation resistance as well, the cables must be disconnected from the electronic module before using the insulation resistance tester.

	<p>WARNING: Applying test voltage to the cables before disconnecting them from the electronics module will seriously damage the electronics module.</p>
---	--

- ▶ Reconnect all cables after the loop resistance test.

	<p>WARNING: Explosion Hazard</p> <ul style="list-style-type: none"> ● In non-intrinsically safe installations, the terminal boxes may only be opened if the system is disconnected from the power supply. ● In non-intrinsically safe installations, the cables may only be disconnected if the system is disconnected from the power supply. ● The window cover must only be opened if the system is disconnected from the power supply and only 10 minutes or more after the system has been switched off, or the area is known to be non-hazardous.
---	--

	<p>NOTICE: Incorrect cabling may cause failure of the FLOWSIC600. This will invalidate warranty claims. The manufacturer assumes no liability for consequential damage.</p>
---	--

3.4.4 Terminal enclosure on the SPU

Opening the rear housing cover

- ▶ Loosen the securing clip using a 3 mm Allen key.
- ▶ Turn the rear housing cover counter-clockwise and take it off.



NOTICE: Lubricant
Only use LOCTITE 8156 as lubricant for front and rear housing cover.

A schematic wiring diagram is provided on the inside of the rear housing cover.

Figure 12

SPU housing

Open the cover

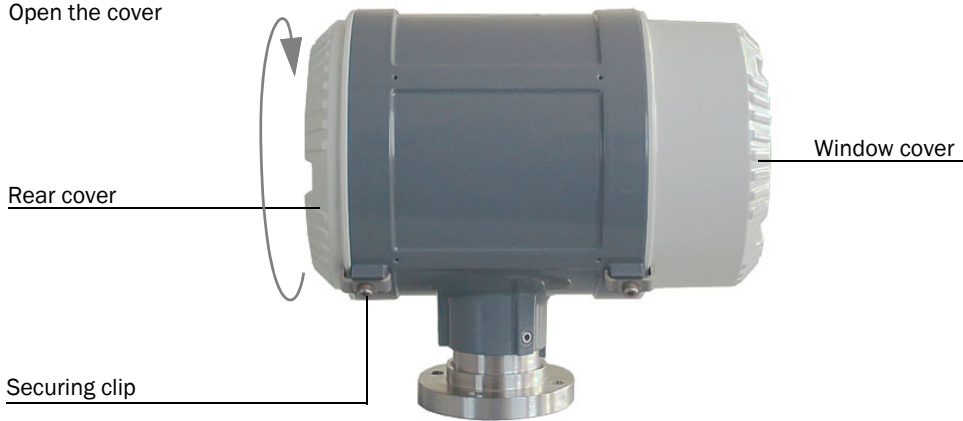
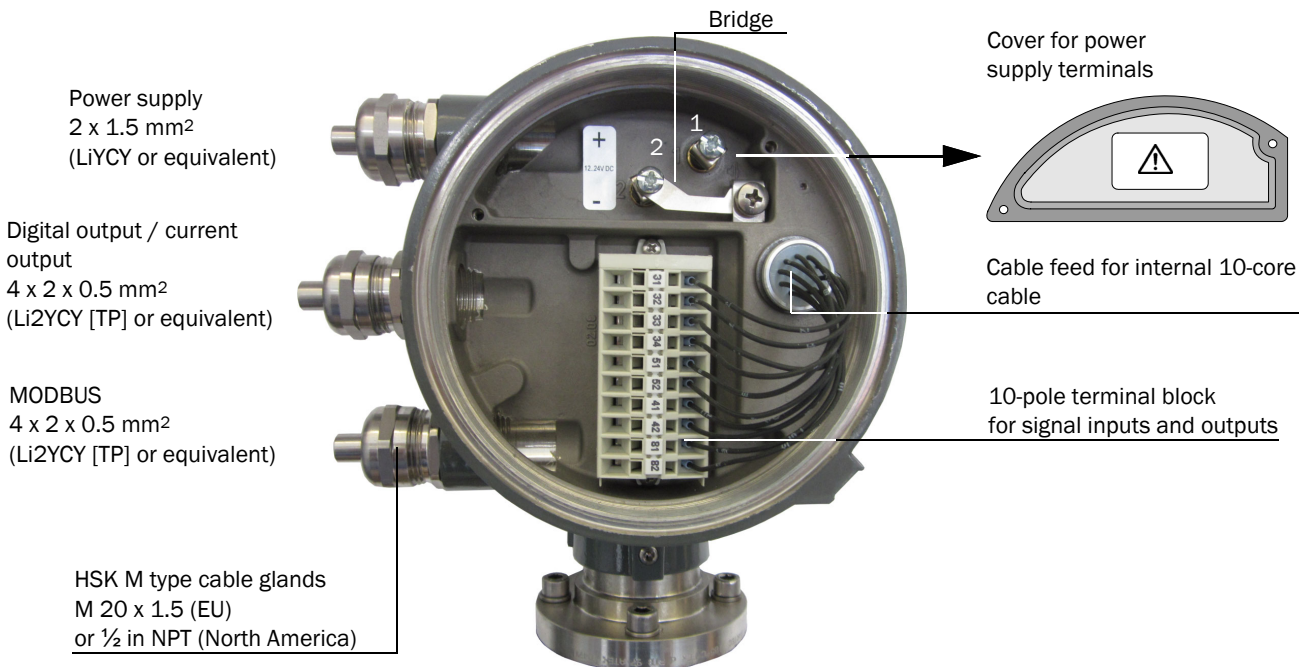



Figure 13

Terminal box on the rear of the SPU (see Section → 3.4.2 for North American wiring specification equivalents)





NOTICE:
During installation, the operating instructions for the cable glands used must be observed and complied with.

Figure 14 Terminal assignment for use in safe areas

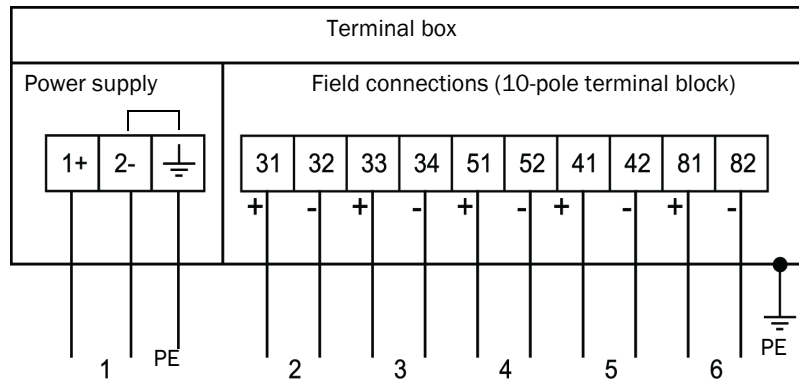

NOTICE: Potential equalization

PE: Potential Equalization terminal must be connected to earth ground.



NOTICE: Device-internal bridge

Terminals 2 and PE are bridged internally, i.e. there is no insulation between PE and negative potential (→ Figure 13).

- ▶ This bridge is a firm part of the device and mandatory. It must not be removed or altered.
- ▶ Altering the bridge voids the manufacturer's warranty.



NOTICE: Termination of Modbus lines

Begin and end of the Modbus lines must be terminated.

- Terminal 81/82: Always terminated
- Terminal 33/34: Switchable, terminated ex factory

For detailed information, see Service Manual FLOWSIC600, Section 4.4 "Serial interface RS485".

3.4.5 Operating the FLWSIC600 in non-hazardous areas

Assign the terminals in the SPU terminal box (→ Figure 14) in accordance with the following table.

No.	Connection for	Function	Terminal	Value	Notes
1	Power supply		1+, 2-	12 ... 24 (+20%) V DC	
2	Digital output DO 0 (HF 2)	Passive	31, 32	$f_{\max} = 6 \text{ kHz}$, configurable pulse duration 0.05 s - 1 s Range: Variable number of pulses per volume unit "closed": $0 \text{ V} \leq U_{\text{CE L}} \leq 2 \text{ V}$, $2 \text{ mA} \leq I_{\text{CE L}} \leq 20 \text{ mA}$ (L=Low) "open": $16 \text{ V} \leq U_{\text{CE H}} \leq 30 \text{ V}$, $0 \text{ mA} \leq I_{\text{CE H}} \leq 0.2 \text{ mA}$ (H=High)	With NAMUR contact for connection to switching amplifier (according to EN 60947-5-6:2000)
3	Serial port	MODBUS (RS485)	33, 34	9600 Baud, 8 data bits, no parity, 1 stop bit	Baud rate to be set through software
4	Digital output DO 1 (HF 1)	Passive	51, 52	$f_{\max} = 6 \text{ kHz}$, configurable pulse duration 0.05 s - 1 s Range: Variable number of pulses per volume unit "closed": $0 \text{ V} \leq U_{\text{CE L}} \leq 2 \text{ V}$, $2 \text{ mA} \leq I_{\text{CE L}} \leq 20 \text{ mA}$ (L=Low) "open": $16 \text{ V} \leq U_{\text{CE H}} \leq 30 \text{ V}$, $0 \text{ mA} \leq I_{\text{CE H}} \leq 0.2 \text{ mA}$ (H=High)	With NAMUR contact for connection to switching amplifier (according to EN 60947-5-6:2000)
5	Digital output DO 2	Passive	41, 42	"closed": $0 \text{ V} \leq U_{\text{CE L}} \leq 2 \text{ V}$, $2 \text{ mA} \leq I_{\text{CE L}} \leq 20 \text{ mA}$ (L=Low) "open": $16 \text{ V} \leq U_{\text{CE H}} \leq 30 \text{ V}$, $0 \text{ mA} \leq I_{\text{CE H}} \leq 0.2 \text{ mA}$ (H=High) "Check request" (default)	
6	Digital output DO 3	Passive	81, 82	"closed": $0 \text{ V} \leq U_{\text{CE L}} \leq 2 \text{ V}$, $2 \text{ mA} \leq I_{\text{CE L}} \leq 20 \text{ mA}$ (L=Low) "open": $16 \text{ V} \leq U_{\text{CE H}} \leq 30 \text{ V}$, $0 \text{ mA} \leq I_{\text{CE H}} \leq 0.2 \text{ mA}$ (H=High) "Direction of flow" (default) (alternative "Warning")	
	Alternative assignment with second serial port (RS485)				9600 Baud, 8 data bits, no parity, 1 stop bit

3.4.6

Requirements for use in hazardous areas with potentially explosive atmospheres

Intended use

The FLOWIC600 is suitable for use in hazardous areas classified as Zone 1 and Zone 2.

Certification in accordance with ATEX

Ⓔ II 1/2 (1) G Ex ia/db eb ia [ia Ga] IIA/IIB/IIC T4 ...T1 Ga/Gb

Ⓔ II 1/2 (1) G Ex ia/db eb ia [ia Ga] IIC T6 Ga/Gb

Permitted ambient temperature range -40 °C to +60 °C

EU-Type Examination Certificate: TÜV 01 ATEX 1766 X, Issue 00, 8. Supplement

IECEX Certification

Ex d e ib [ia Ga] IIA T4 Ga/Gb

Ex d e ib [ia Ga] IIC T4 Ga/Gb

Permitted ambient temperature range -40 °C to +60 °C, optionally - -50 °C to +70 °C

IECEX Certificate of Conformity: IECEX TUN 11.0001 X

Figure 15

FLOWIC600 components and their type of protection

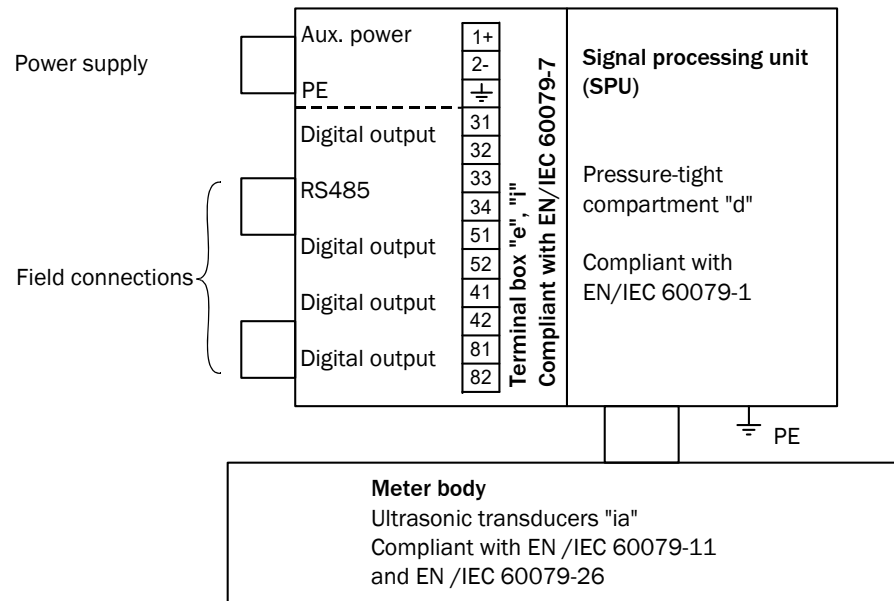

Operating conditions for the ultrasonic transducers

The FLOWSIC600 is designed for use in hazardous areas with potentially explosive atmospheres only under normal atmospheric conditions. The atmospheric conditions must be within the following ranges:

- Ambient pressure range 80 kPa (0.8 bar) to 110 kPa (1.1 bar)
- Air with normal oxygen content, typically 21% v/v

The ambient temperature must be within the range specified at the SPU type plate, e.g -40°C to +60°C.

Once the FLOWSIC600 is installed in the pipeline, the meter body becomes a part of the pipeline. The wall of the pipeline and the meter body is then deemed a zone-separating barrier. The figure below helps in understanding the different situations for a possible application and shows what operating conditions apply.

Figure 16

Ex-Zones

Case 1:

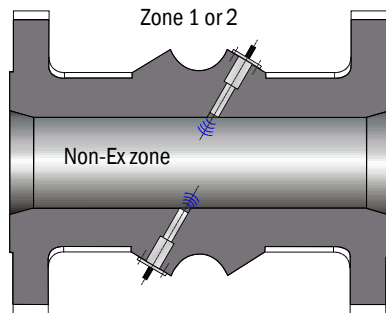

- The pipeline contains a non-explosive mixture. The gas mixture may be combustible.
- Gas pressure and gas temperature may be within the range specified by the tag on the meter body.

Case 2:

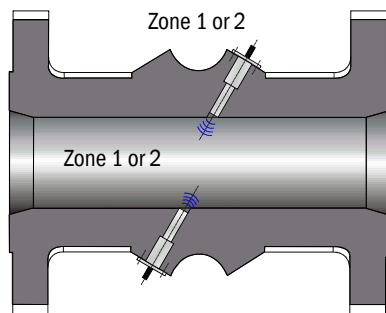

- The area inside the pipeline is classified as hazardous area Zone 1 or 2.
- Gas pressure must be in the range from 80 kPa to 110 kPa (normal atmospheric condition)
- Gas temperature must be within the permitted ambient temperature range specified by the type plate on the SPU

Case 3:

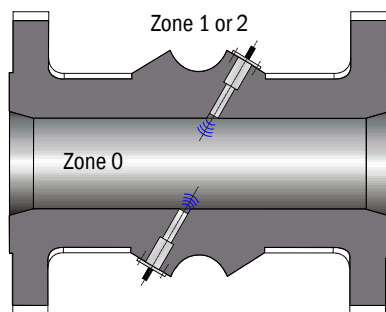

- The area inside the pipeline is classified as hazardous area Zone 0.
- Gas pressure must be in the range from 80 kPa to 110 kPa (normal atmospheric condition)
- Gas temperature must in the range from -20°C to 60°C.

Operation of ultrasonic sensors in Zone 0

The ultrasonic transducers are suitable for operation in Zone 0 at atmospheric conditions, i.e. ambient temperature -20 °C to 60 °C and ambient pressure 0.8 bar to 1.1 bar(a). If ultrasonic transducers with titanium housing are to be used in Zone 0, it must be assured that the medium does not transport solid parts (like dust or other particles) which could cause an ignition hazard. Otherwise, transducers made from stainless steel must be used. After installation and following every de-installation and reinstallation of the ultrasonic transducers, the seal effect must be appropriately checked. During operation, the leak-tightness must be periodically checked and the seals replaced if necessary. After de-installation and before every reinstallation the seals must be replaced according to the original assembly. Seals can be ordered from Endress+Hauser (part number and serial number from type plate at SPU).

	<p>WARNING:</p> <p>The maximum piezo-electric energy released by impact on the ultrasonic transducers exceeds the limit for Gas Group IIB and IIC specified in Clause 10.7 of EN 60079-11:2012. This shall be considered during installation and operation.</p>
---	--

	<p>NOTICE:</p> <p>The rise in the ambient temperature outside the pipeline due to a hot pipeline must be taken into account.</p> <p>The user must ensure that the ambient temperature around the electronics housing does not exceed the maximum permitted ambient temperature marked on the type plate of the FLOW SIC600.</p>
---	--

General requirements for installation

- The documentation for hazardous area classification (zone classification) according to EN/IEC60079-10 must be available.
- The equipment must be verified as suitable for use in the classified area.
- Additional requirements must be observed for use of transducers in Zone 0 as described above.
- After installation an initial test run of the complete equipment and the plant according to EN/IEC60079-17 must be performed before regular operation is started.

Requirements regarding cabling

- Cables must fulfill the requirements set forth in EN/IEC60079-14.
- Cables that are subject to exceptional thermal, mechanical or chemical stress must be specially protected, e.g. by laying them in protective tubing.
- Cables that are not installed fire proof must be flame retardant according to IEC 60332-1.
- Cables for Ex e must comply with EN/IEC 60079-14 section 11.
- Observe the clamping range of the cable glands for cable selection.
- Use Ex e respectively Ex i certified cable glands with adequate ingress protection rating as alternate replacement only.
- For intrinsically safe wiring and an ambient temperature range between -20 °C to +60 °C, the existing metal cable glands may be replaced with light-blue plastic cable glands (available on request).
- Replace the existing cable glands with suitable cable glands if installation with armored cables is intended.
- When delivered, the cable glands are secured by default with a sealing plug. If the cable glands are not used, only sealing plugs with Ex e approval must be used.
- Conduit systems must comply with EN/IEC 60079-14, section 9.4 and 10.5. In addition, compliance with national and other relevant regulations is required
- "Conduits" according to IEC 60614-2-1 and IEC60614-2-5 are not suitable.
- Conduits must be protected against vibration.
- Use a suitable thread sealant, as detailed in EN/IEC60079-14, section 9.4.
- Protect stranded wires against fraying with ferrules.
- Keep clearance and creepage distances for the connected wires in accordance with EN/IEC60079 and EN/IEC 60079-11 respectively.
- Connect unused wires to ground or safeguard so that a short circuit with other conductive parts is excluded.
- Carry out potential equalization in accordance with EN/IEC6079-14
- The meter body and the electronic housing must be connected to the potential equalization.
- Where the FLOWSIC600 is installed in a grounded metal duct, no additional grounding is required for the meter body. The electronics housing must nevertheless be separately grounded.

Connection of the FLOWSIC600 with associated equipment

The terminal compartment of the FLOWSIC600 complies with the requirements of EN/IEC60079-7 and EN/IEC 60079-11, respectively.

The FLOWSIC600 provides non-intrinsically safe wiring as well as intrinsically safe wiring with the interconnected associated equipment in the following manner:

- 1 Power supply connection and all other field connections as non-intrinsically safe wiring
- 2 Power supply connection and all other field connection as intrinsically safe wiring to Exi certified equipment in a Zone 1 or Zone 2 classified hazardous area or to [Exi] certified associated equipment in the safe area.
- 3 Power supply connection as non-intrinsically safe wiring and all other filed connection as intrinsically safe wiring.
- 4 Power supply connection as intrinsically safe wiring and all other filed connections as non-intrinsically safe wiring.

A combination of intrinsically safe and non-intrinsically safe wiring for the field connections is not permitted.

Maximum voltage in the safe area must not exceed 253 V (Um = 253V).

For intrinsically safe wiring:

- The safety-relevant data in the EC Type Examination Certificate and the IECEx Certificate of Conformity must be observed.
- Intrinsic safety for each circuit must be assessed in accordance with EN/IEC60079-14 section 12.
- The safety-relevant parameters of interconnected equipment must comply with the following values: $U_o < U_i$, $I_o < I_i$, $P_o < P_i$, $C_i + C_{cable} < C_o$, $L_i + L_{cable} < L_o$

The interconnection of two or more intrinsically safe outputs may require an additional assessment of intrinsic safety in accordance with EN /IEC60079-11.

Ensure that the cover on the power supply connection is properly sealed for regular operation. The use of the power supply cover is mandatory for the connection variants 3 and 4, see above.

For intrinsically safe wiring, the rear cover can be removed and connecting and disconnecting is permitted while the circuits are live and as long as the safe separation between the circuits has been kept.

	<p>WARNING: Explosion Hazard</p> <ul style="list-style-type: none"> ● Do not open the enclosure while energized. ● Wait 10 minutes after power has been removed before opening the window cover. ● Do not open the cover of the terminal compartment while energized unless wiring is intrinsically safe. ● Do not remove the cover of the power supply while energized unless wiring is intrinsically safe. ● Do not connect or disconnect while circuits are live unless the area is known to be non-hazardous or wiring is intrinsically safe. ● Do not use the equipment if damaged (includes cables or terminals).
---	--

Terminal assignment

The terminal assignment in the SPU terminal box (see → pg. 43, Figure 14) is the same as for the installation of the FLAWSIC600 in non-hazardous areas (see table → pg. 44, 3.4.5).

**NOTICE:**

For measurement reasons, the equipotential bonding must, as far as possible, be identical to the pipeline potential or protective ground/earth. Additional grounding with the protective conductor via the terminals is not permitted!

The connections of the ultrasonic transducers are intrinsically safe and are safely separated from one another and from other non-intrinsically safe circuits. The transducers may be connected and disconnected during operation as long as the safe separation of circuits has been preserved in every respect. In order to ensure this, the respective transducer connection cable should be disconnected at both ends (disconnect the electronics side first, and then if necessary, the transducer side unless the MCX connector is suitably fixed to prevent any uncontrolled movement). Operation using sensors or cables not part of the original delivery or with sensors/components from other manufacturers is not permitted.

**NOTICE:**

Replace backup battery with PANASONIC type BR2032, Endress+Hauser part no. 7048533. It may only be replaced by trained staff.

Specific requirements for installation and use in North America

Certificate no. CSA02CA1298901X

The device is suitable for use in hazardous areas according to the respective device versions, → S. 107, § 7.1.5 "Technical data".

Installation

- Install in the US in accordance with the NEC.
- Install in Canada in accordance with CEC part 1.

For further details see drawing no. 9418408, → S. 143, § 7.7.

Notes for safe operation in hazardous areas



WARNING:

Always observe the temperature specifications for use in hazardous areas.



Approval of the ultrasonic transducers in zone 0 is only valid for operation under atmospheric conditions.

- Explosion protection:
 - ⊕ II 1/2 (1) G Ex ia/db eb ia [ia Ga] IIA/IIB/IIC T4 ...T1 Ga/Gb
 - ⊕ II 1/2 (1) G Ex ia/db eb ia [ia Ga] IIC T6 Ga/Gb
- Ambient temperature range is from -40 °C to +60 °C.
- If terminals are assigned with intrinsically safe circuits, it is recommended that the metal cable glands be replaced with the light-blue plastic ones
- The type of protection for the field connections and power supply connection is determined by the external circuits that are connected (for options see "Connection options" above).
- Safety-relevant data for intrinsically safe circuits is provided in the EC Type Examination Certificate and the IEC Certificate of Conformity.
- Ensure that the cover on the power supply connection is properly sealed. In intrinsically safe installations, the terminal box can be opened and cables connected and disconnected while the system is live. In this case the safe separation of the circuits from each other must be observed.
- If the meter body is insulated, the insulation thickness must not exceed 100 mm. The SPU housing must not be insulated.
- The standard paint of the FLOWSIC600 meter body consists of a double layer: Epoxy and Acrylic RAL9002. This combination is the ideal protection of the meter body against corrosion. The layer thickness is less than 0.2 mm.
- The maximum piezo-electric energy released by impact on the ultrasonic transducers exceeds the limit for Gas Group IIB and IIC. The ultrasonic transducers must be protected against impact.
- Special conditions for use in zone 0: "The devices complying with this standard are intended for use in hazardous areas in which explosive atmospheres exist under normal atmospheric conditions of temperature -20 °C to +60 °C, pressure 80 kPa (0.8 bar) to 110 kPa (1.1 bar), and air with normal oxygen content, typically 21 % v/v. The application of electrical equipment in atmospheric conditions outside this range requires special consideration and may require additional assessment and testing."
- For the whole area of erection of the apparatus potential equalisation have to be ensured. The protective earth conductor terminals of the apparatus shall be connected to the potential equalisation.
- The combination of intrinsically safe circuits and non-intrinsically safe circuits for the field connections are not allowed.
- The joints of the apparatus exceed the safety level which is defined in table 2 of the EN 60079-1:2014.



WARNING: Explosion Hazard

The ultrasonic probes are preferably made from titanium.

- ▶ Should zone 0 or zone 1 have been defined in the pipeline, operation is allowed only when ignition hazards caused by impact or friction can be excluded.

**WARNING: Ignition hazard through electrostatic discharges**

Ignition hazards through electrostatic discharges exist when gas flow meters with special paint and a layer thickness >0.2 mm are used in applications with ignition group IIC in accordance with ATEX and IECEx.

- ▶ For installation, the risk of electrostatic charging of the surface must be reduced to a minimum.
- ▶ Use appropriate caution when performing maintenance and cleaning work. For example, the surfaces should only be cleaned with a damp cloth.
- ▶ A warning sign fitted at the factory identifies this type of device:



Safety-relevant data of inputs and outputs for ATEX certified FLOWSIC600 only

Power circuit	Intrinsically safe Ex ia/ib IIA/IIB/ IIC							Non-intrinsically safe
Power supply	U _I = 20 V, P _I = 2,6 W, I _I = 200 mA, C _i and L _i negligible							12...24 V DC max. 30 V DC
Active current output Terminals 31/32	U ₀ = 22.1V							U _B = 18 V U _B = 35 mA
	I ₀ [mA]	P ₀ [mW]	Ex ia/ib IIA		Ex ia/ib IIB		Ex ia/ib IIC	
			C ₀ [μF]	L ₀ [mH]	C ₀ [μF]	L ₀ [mH]	C ₀ [nF]	L ₀ [mH]
Hardware variant 1-5,7/9, A	155	856	2	6	0.5	3	77	0.75
Hardware variant 6, B	87	481	2	7	0.5	4	77	1
	Characteristic curve: linear or for connection to certified intrinsically safe circuits with the following maximum values: U _I = 30 V I _I = 100 mA P _I = 750 mW Internal capacity: C _i = 4.4 nF Internal inductance: negligible							
Digital output Terminals 51/52 Terminals 41/42 Terminals 81/82	For connection to certified intrinsically safe circuits with the following maximum values: U _I = 30 V I _I = 100 mA P _I = 750 mW Internal capacity: C _i = 4.4 nF Internal inductance: negligible							U _B = 30 V I _B = 100 mA
RS485 Terminals 33/34 Terminals 81/82	Characteristic curve: linear U ₀ = 5.88 V I ₀ = 316 mA P ₀ = 465 mW C ₀ = 1 μF for IIA resp. 430 nF for IIC L ₀ = 2 mH for IIA resp. 0.2 mH for IIC or for connection to certified intrinsically safe circuits with the following maximum values: U _I = 10 V I _I = 275 mA P _I = 1420 mW Internal capacity: C _i = 4.4 nF Internal inductance: negligible							U _B = 5V I _B = 175 mA
Ultrasonic transducer connections (for connecting Endress+Hauser ultra- sonic transducers only)	Ex ia/ib IIA		Ex ia/ib IIB		Ex ia/ib IIC			
	Characteristic curve: linear Max. transmission voltage: U ₀ = ±60.8 V Short-circuit current: I ₀ = ±92 mA P ₀ = 1399 mW Internal capacity: C _i = negligible Internal inductance: L _i = 20.6 mH C ₀ = 300 nF L ₀ = 13 mH		U ₀ = ±51.2 V I ₀ = ±77 mA P ₀ = 986 mW negligible L _i = 15.5 mH C ₀ = 184 nF L ₀ = 8.5 mH		U ₀ = ±38.9 V I ₀ = ±59 mA P ₀ = 574 mW negligible L _i = 6.7 mH C ₀ = 34.2 nF L ₀ = 3.9 mH			
SPU-Link (Terminals 9-10 MCX/ TNC-Socket)	Ex ia IIA		Ex ia IIB		Ex ia IIC			
	Characteristic Curve: linear Max. transmission voltage: U ₀ = 12.3 V Short-circuit current: I ₀ = 130 mA P ₀ = 400 mW Internal capacity: C ₀ = 15.5 μF Internal inductance: L ₀ = 7 mH		U ₀ = 12.3 V I ₀ = 130 mA P ₀ = 400 mW C ₀ = 4.05 μF L ₀ = 4 mH		U ₀ = 12.3 V I ₀ = 130 mA P ₀ = 400 mW C ₀ = 600 nF L ₀ = 1 mH			

**WARNING:**

$U_m = 235 \text{ V}$: For intrinsically safe installation, maximum voltage in the non-hazardous area must not exceed 253 V

- The intrinsically safe probe circuits and SPU-Link and supply circuit are galvanically connected.
- The intrinsically safe probe circuits and SPU-Link and supply circuit are safely galvanically separated from the field connections non up to the peak crest value of the voltage of 375 V.

Safety-relevant data of inputs and outputs for IECEx certified FLOWSIC600 only

Power circuit	Intrinsically safe Ex ia/ib IIA/IIB/ IIC							Non-intrinsically safe
Power supply	$U_i = 20\text{ V}$, $P_i = 2,6\text{ W}$							12 ... 24 V DC
Active current output Terminals 31/32	$U_o = 22.1\text{ V}$							$U_B = 18\text{ V}$ $U_B = 35\text{ mA}$
	I_o [mA]	P_o [mW]	Ex ia/ib IIA C_o [μF] L_o [mH]		Ex ia/ib IIB C_o [μF] L_o [mH]		Ex ia/ib IIC C_o [nF] L_o [mH]	
All hardware variants	87	481	2	7	0.5	4	77 1	
	Characteristic curve: linear or for connection to certified intrinsically safe circuits with the following maximum values: $U_i = 30\text{ V}$ $I_i = 100\text{ mA}$ $P_i = 750\text{ mW}$ Internal capacity: $C_i = 4\text{ nF}$ Internal inductance: negligible							
Digital output Terminals 51/52 Terminals 41/42 Terminals 81/82	For connection to certified intrinsically safe circuits with the following maximum values: $U_i = 30\text{ V}$ $I_i = 100\text{ mA}$ $P_i = 750\text{ mW}$ Internal capacity: $C_i = 4\text{ nF}$ Internal inductance: negligible							$U_B = 30\text{ V}$ $I_B = 100\text{ mA}$
RS485 Terminals 33/34 Terminals 81/82	Characteristic curve: linear $U_o = 5.88\text{ V}$ $I_o = 313\text{ mA}$ $P_o = 460\text{ mW}$ $C_o = 1000\ \mu\text{F}$ for IIA resp. $43\ \mu\text{F}$ for IIC $L_o = 1.5\text{ mH}$ for IIA resp. 0.2 mH for IIC or for connection to certified intrinsically safe circuits with the following maximum values: $U_i = 10\text{ V}$ $I_i = 275\text{ mA}$ $P_i = 1420\text{ mW}$ Internal capacity: $C_i = 4\text{ nF}$ Internal inductance: negligible							$U_B = 5\text{ V}$ $I_B = 175\text{ mA}$
Ultrasonic transducer connections (for connecting Endress+Hauser ultrasonic transducers only)	Ex ia/ib IIA		Ex ia/ib IIB		Ex ia/ib IIC			
	Characteristic curve: linear Max. transmission voltage: $U_o = \pm 60.8\text{ V}$ Short-circuit current: $I_o = \pm 92\text{ mA}$ $P_o = 388\text{ mW}$ Internal capacity $C_i =$ negligible Internal inductance: $L_i = 20.6\text{ mH}$		$U_o = \pm 51.2\text{ V}$ $I_o = \pm 77\text{ mA}$ $P_o = 372\text{ mW}$ negligible $L_i = 15.5\text{ mH}$		$U_o = \pm 38.9\text{ V}$ $I_o = \pm 59\text{ mA}$ $P_o = 248\text{ mW}$ negligible $L_i = 6.7\text{ mH}$			

	<p>WARNING: $U_m = 235\text{ V}$: For intrinsically safe installation, maximum voltage in the non-hazardous area must not exceed 253 V</p>
---	---

FLOWSIC600

4 Commissioning

General notes

Connecting the FLOWSIC600 to a PC or laptop

Connecting to the FLOWSIC600 with FLOWgate™

Identification Field setup

Function test

Activation of path compensation

Sealing

Documentation

4.1

General notes

Before commissioning, all activities described in the chapter »Installation« must be completed. It is recommended to use a laptop/PC with FLOWgate™ software installed for the commissioning (→ pg. 61, 4.3). The commissioning should be documented with a Commissioning Protocol. The document "FLWSIC600 Commissioning Protocol" is content of the FLWSIC600 shipping on paper and on the product CD.

The FLWSIC600 is 'wet' or 'dry' calibrated when delivered to the end user. The 'dry' calibration consists of the 3-D measurement of the meter body, zero-flow and speed of sound test, and other system specific inspections/tests which belong to the manufacturing and quality assurance process. The 'wet' calibration is performed at a flow calibration test stand (calibration test facility).

All parameters, determined by the aforementioned tests, as well as design specific data are preset and stored in the FLWSIC600 in a non-volatile memory before delivery. The design-specific data, which is known before manufacturing the device, will not be changed during commissioning. This is of special importance if the FLWSIC600 is officially sealed after an authorized flow calibration. Generally, the parameters are protected by a password. Additionally a Parameter write lock in the SPU prevents custody relevant parameter changes.

In all other cases the output parameters of the FLWSIC600 can be adapted on site by trained staff.

Commissioning the FLWSIC600 involves the following steps, regardless of whether the device is installed at a test facility or at the final measuring location:

- Connecting the FLWSIC600 to a PC or Laptop (→ pg. 59, 4.2)
- Connecting to the FLWSIC600 with FLOWgate™ (→ pg. 61, 4.3)
- Identification (→ pg. 66, 4.4)
- Field setup (→ pg. 67, 4.5)
- Function test → pg. 69, 4.6,
- Optional additional setup (→ pg. 72, 4.7)
- Activation of path compensation (→ pg. 80, 4.8)
- Sealing (→ pg. 80, 4.8.1),
- Documentation (→ pg. 80, 4.9)

4.2 **Connecting the FLOWSIC600 to a PC or laptop**

4.2.1 **Connecting the FLOWSIC600 via RS485 / RS232 cable**

+i Interface sets for the connection of the FLOWSIC600 with a PC via serial or USB-interface can be ordered from Endress+Hauser. See → pg. 60, Table 3.

The FLOWSIC600 serial interface conforms with the RS485 standard. An RS485 /RS232 cable and a 1:1 interface cable (pin 2 – pin 2 and pin 3 – pin 3) are required for data transfer to PC or laptop (see → Figure 17). Because FLOWgate™, the operation and diagnosis software for the FLOWSIC600, does not support RTS/CTS data transfer, the adapter must be able to distinguish between transmission and reception mode automatically. We, therefore, recommend the use of a serial interface set available from Endress+Hauser.

Figure 17 Wiring example of "MEPA interface set RS485 / RS232" intrinsically safe for DIN rail mounting

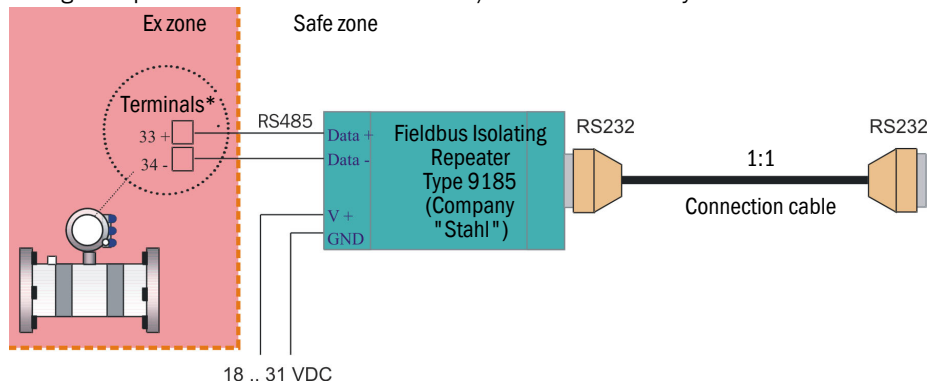

+i *Possible terminals for the RS485 connection are:

- 33 (+) and 34 (-)
- 81 (+) and 82 (-)

If necessary, the RS485 ports can be assigned to a specific bus address (Reg. #5020 "DeviceBusaddress"). The service port always has the bus address "1".

4.2.2 **Connecting the FLOWSIC600 via RS485/USB converter**

The FLOWSIC600 can be connected with the laptop/PC and configured using a separate RS485/USB.

Figure 18 Wiring example for "Interface set RS485/USB" non-intrinsically safe

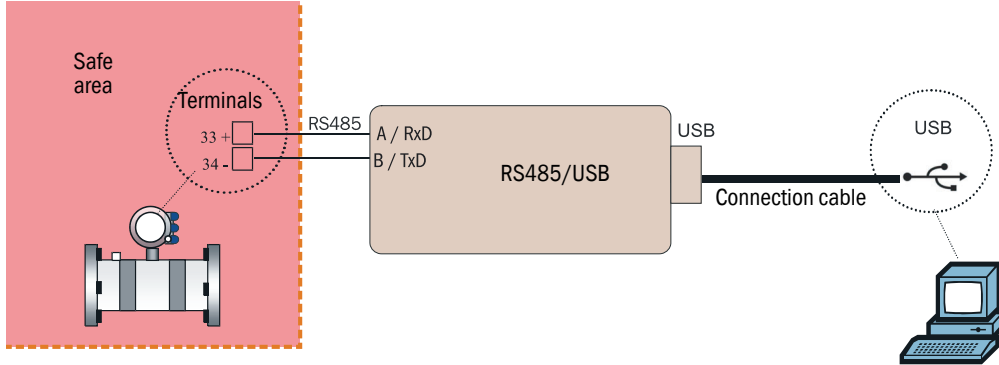

+i Possible terminals for the RS485 connection are:

- 33 (+) and 34 (-)
- 81(+) and 82(-)

If necessary, the RS485 ports can be assigned to a specific bus address (Reg.#5020 "DeviceBusaddress"). The service port always has the bus address "1".

The RS485/USB converter is available from Endress+Hauser using the following item number

Table 3 Interface sets for the connection of the FLOWSIC600 to a network

Description	Part Number
"MEPA interface set RS485/USB" (Converter, cable, terminal plug, CD-ROM with software driver), non-intrinsically safe	6030669

4.3 **Connecting to the FLWSIC600 with FLOWgate™**

4.3.1 **Starting FLOWgate™**

The FLOWgate™ software is provided on the product CD shipped with the meter. It can also be downloaded from www.endress.com/downloads. See → pg. 25, for more details on the installation.

- ▶ After successful installation, start the FLOWgate™ by selecting the "FLOWgate™" entry in the program group "SICK", created during installation, or by double-clicking on the desktop icon.
- ▶ After starting FLOWgate™ the device manager appears. Here you can connect to new devices, already once connected devices and offline devices.
 - If connecting online the first time with the device you can scan for it.
 - If the device was already connected, you can choose it from the lists and connect online or offline.
 - If the device is new and offline you can use "CreateOffline".

4.3.2 **Creating a new meter entry in the meter database**

+i New meter entries can be created, whether the corresponding meter is connected to the PC or not. If the meter is connected, FLOWgate™ loads all available parameters from the meter. If the meter is not connected, an initial master data set is created from the information the user enters (see Technical Data).

- ▶ Open the "DeviceManager" tab.
- ▶ Click "Create Offline" to create a new device that is not connected.
- ▶ Choose FLWSIC600 in "Add Offline Device" window and type in the serial number. For testing you can create a device that do not exist with fictitious serial number.
- ▶ Type in the device information for FLWSIC600.

Figure 19 FLOWgate™ "DeviceManager" dialog window

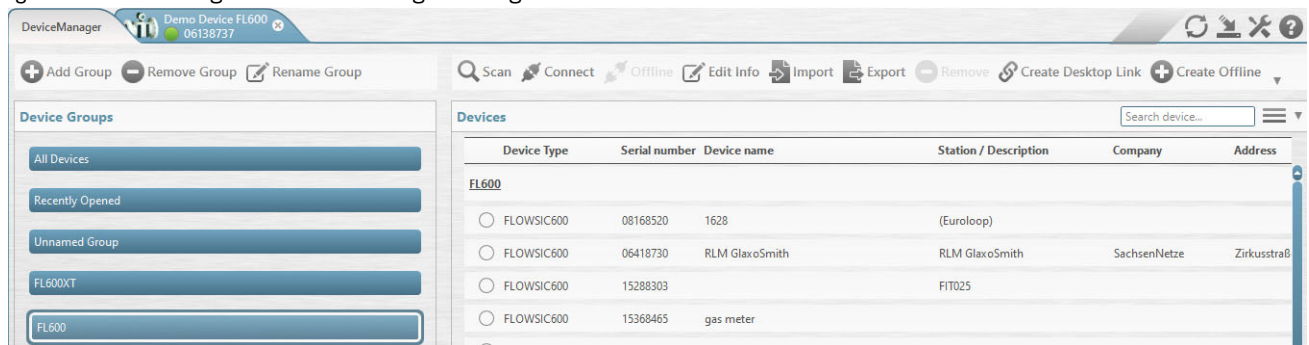

4.3.3

Online connection: Direct serial

- ▶ Choose a meter and click the "Connect" button to establish a serial connection to a meter which is connected to the PC (→ Figure 20).
- ▶ If the device was already connected to FLOWgate™, the connection is established automatically. Otherwise use the "Scan" button.
- ▶ For serial connection use the "Serial Port" checkbox and push "Configure for Scan".
- ▶ Specify the appropriate connection settings in the "Configure Serial Connection" window (→ Figure 20) and click the "OK" button. Press "Start Scan" and FLOWgate™ will scan for devices in the configured settings. If the right settings are unknown, a range of settings can be used. Standard settings are shown in the Screenshot (→ Figure 20)
- ▶ Connect to the founded device by clicking "Connect device" button (→ Figure 21). If the connection fails, see → pg. 101, 6.4 for troubleshooting.

Figure 20

Connection settings

Configure Serial Connection

ComPorts <input checked="" type="checkbox"/> COM3 USB Serial Port	Baudrates <input type="checkbox"/> 1200 <input type="checkbox"/> 2400 <input type="checkbox"/> 4800 <input checked="" type="checkbox"/> 9600 <input checked="" type="checkbox"/> 19200 <input checked="" type="checkbox"/> 38400 <input type="checkbox"/> 57600 <input type="checkbox"/> 115200 <input type="checkbox"/> 230400	Parity <input checked="" type="checkbox"/> None <input type="checkbox"/> Odd <input type="checkbox"/> Even
Protocols <input checked="" type="checkbox"/> MODBUS RTU <input checked="" type="checkbox"/> MODBUS ASCII <input checked="" type="checkbox"/> SICK MODBUS RTU <input checked="" type="checkbox"/> SICK MODBUS ASCII <input type="checkbox"/> MODBUS RTU Long Frame	DataBits <input type="checkbox"/> 7 <input checked="" type="checkbox"/> 8	StopBits <input checked="" type="checkbox"/> 1 <input type="checkbox"/> 2
Info Scan will take approx. 18 seconds.	Address <input checked="" type="checkbox"/> 1 <input type="checkbox"/> All (1-254) <input type="checkbox"/> 1-32	Timeout 1500 [ms]



The parameters shown in the "Connection Settings" window in → Figure 20 are the default values with which the FLOWsic600 RS485 interface is configured. The serial COM port must be individually selected.

Figure 21

Connection device



- ▶ Choose a user access level for Login.
- ▶ By using the "Remember password" checkbox, the access level and password will be insert automatically at next Login.

User access level	Password
Operator	No password required
Authorized operator	"sickoptic"
Service	See Service Manual

- ▶ Edit the fields for the meter identification in the "Add new meter into database" dialog. The serial number, firmware version and meter type are automatically read from the meter → Figure 22.
- ▶ The device information can be edited later by using the "Edit Info" button in the device manager.
- ▶ After the connection has been established, FLOWgate™ displays the start page (can be specified in the Program settings) and the current readings from the meter.

Figure 22

Adding new meter to database

Edit Device Information for FLOWSIC600

06138737
Serial number

0
Part number

Demo Device FL600
Device name

Ottendorf-Okrilla
Station / Description

SICK
Company

ET
Address

ZIP/Postal code City

Country

0 0
Latitude Longitude

Undo Changes

OK Cancel

4.3.4 Online connection: Ethernet

The FLOWSIC600 can be connected to a network via Ethernet with an adapter. This adapter translates the meter MODBUS communication (ASCII or RTU) to MODBUS TCP. FLOWgate™ supports the MODBUS TCP protocol.



Requirements

- The Ethernet connection requires firmware V3.3.05 or higher. It provides the required generic MODBUS protocol on the interface for the MODBUS TCP adapter.
- The FLOWSIC600 must be connected to a MODBUS ASCII/ MODBUS RTU to MODBUS TCP adapter, which is connected to a network via Ethernet and receives a - preferably permanent - IP address.
- The PC with FLOWgate™ or higher installed must be connected to the network and have uninhibited access to this IP address.

Preparations for online connections via Ethernet

- ▶ Make sure one of the serial ports (terminals 33/34 or 81/82) of the FLOWSIC600 is configured to use Generic MODBUS RTU or Generic MODBUS ASCII (NOT a Endress+Hauser MODBUS protocol).
- ▶ Make sure the serial port is configured so that the highest baud rate is used (56000 baud).
- ▶ Connect a MODBUS RTU/MODBUS ASCII to MODBUS TCP adapter to the serial port according to the manual of the adapter.
- ▶ Connect the adapter cable to your network.
- ▶ Make sure the network assigns a permanent IP address to the adapter.
- ▶ Configure the adapter to the network settings (IP address / protocol / baudrate / gateway etc.) that you want to use (refer to adapter manual).
- ▶ Make sure the PC with FLOWgate™ has access to the adapter's IP address.
- ▶ Make sure you know the MODBUS bus address of the meter.

In case of problems with the network setup, refer to your network administrator.

- ▶ Select "Ethernet" in the Interface Selection window and click "Configure for Scan" to establish a connection via Ethernet.
- ▶ Specify the IP address of the MODBUS TCP adapter and the bus address of the meter in the dialog "MODBUS TCP - MODBUS RTU/ASCII gateway settings" (→ Figure 23).
- ▶ Click "OK" to establish an online connection to the meter.

Figure 23 "MODBUS TCP - MODBUS RTU/ASCII gateway settings" dialog for online connections via Ethernet

Configure Ethernet Connection

Device IP Address <input checked="" type="checkbox"/> 127.0.0.1 <input type="checkbox"/> 10.133.87.267 +	Port <input checked="" type="checkbox"/> 502 <input checked="" type="checkbox"/> 503 <input type="checkbox"/> 504 +	Address <input checked="" type="checkbox"/> 1 <input type="checkbox"/> 1-32 <input type="checkbox"/> All (1-254)
Protocol <input type="checkbox"/> RTU over TCP <input type="checkbox"/> Long Frame		Timeout 1000 [ms]

Info
Scan will take approx. 2 seconds.

OK Set to Default Select All Cancel

4.4 Identification

Checking identification, operation / design data and firmware version

Before commissioning, compare the FLOWSIC600 data with the data in the test protocols contained in the "Manufacturer Data Report" (MDR). This can be done using the LCD on the FLOWSIC600 or using FLOWgateTM.

- Open menu "Overview" and compare the data in Section "Device identification" with the test protocols in the MDR. .

 If the FLOWSIC600 is precalibrated, compare with the Calibration report and Parameter report instead of the MDR.

Firmware

The FLOWSIC600 firmware is stored in a non-volatile memory (FLASH PROM). The program codes for the signal processor and system micro-controller are identified by a version number (Reg. #5002 "FirmwareVersion") and a checksum (Reg. #5005 "ProgramCRC") and can be verified as mentioned above.

 **NOTICE: Type approval**
 If the FLOWSIC600 is used for fiscal metering, the approved firmware versions and the associated check sums are documented in the national pattern approval certificates.

Figure 24 "Overview" page



4.4.1 Firmware

The FLOWSIC600 firmware is stored on a non-volatile memory (FLASH PROM). The program code for the signal processor and system micro-controller are identified by a version number (Reg. #5002 "FirmwareVersion") and a check sum (Reg. #5005 "ProgramCRC") and can be verified as mentioned above.

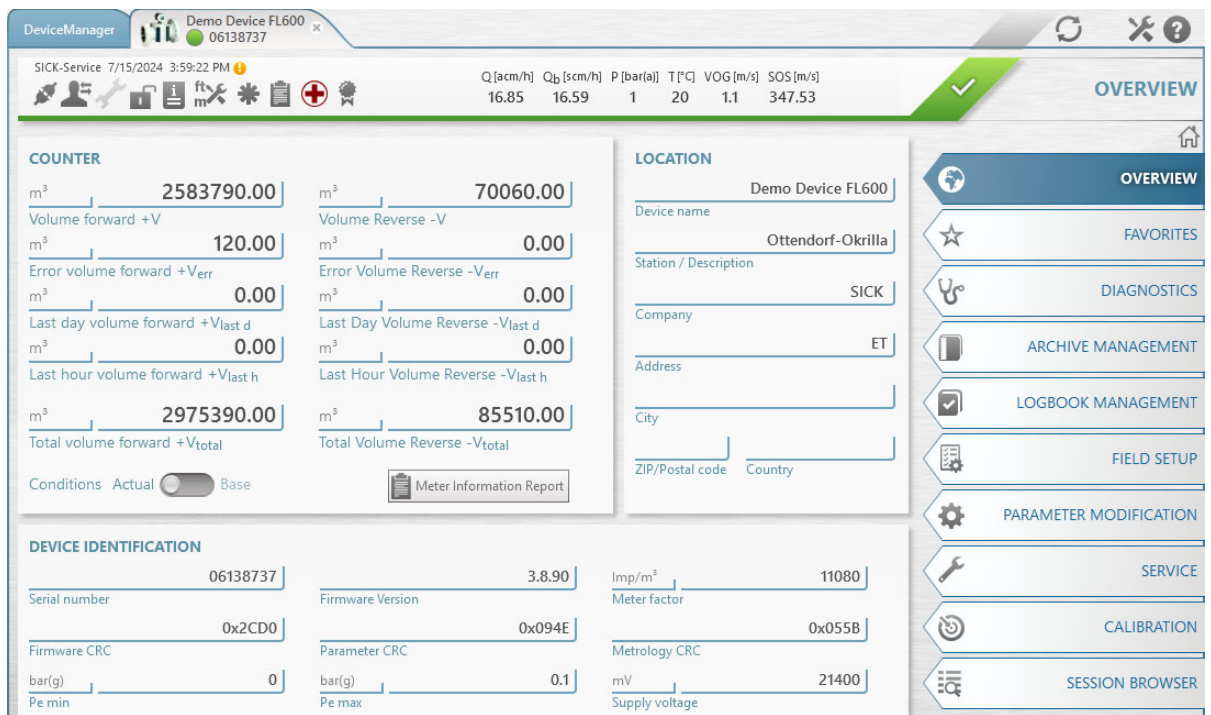
4.5 **Field setup**

The FLOWgate™ wizard "Field setup" guides the user through the parameter configuration during the commissioning of the FLOWSIC600. The wizard consists of 8 pages. For checking the configuration of the SPU outputs refer to the "Instrument Data Sheet" of the FLOWSIC600, which is included in the Manufacturer Data Record (MDR) (example see → Figure 25).

 The parameter changes performed in the Field setup wizard require the User Access Level "Authorized operator" (see → pg. 61, 4.3.2).

- ▶ To start the Field setup, choose "Field Setup" from the menu.
- ▶ Follow the instructions on screen step by step.

Figure 25 Example of an "Instrument Data Sheet" as contained in the MDR

1 GENERAL			54 TRANSMITTER (Integral)		
2 Meter-No.: 3889			56 * Power supply / Power consumption 12 .. 28,8 V DC < 1W		
3 Type FL600			57 * Enclosure classification IP 67		
4 Meter size 06" / DN150			58 * Cable entry M20 x 1,5 (3x)		
5 * Article number			* 59 Hazardous Area Class.		
6 * TAG number			II 1/2G Eex de ib [ia] IIA T4		
7 *					
8 * Order number 01/11-2			60 SPU housing material Aluminium		
9 METER BODY			* 61 Ambient temperature (range) °C -40 ... 60		
10 Inner pipe diameter mm 147,00			62 Display LCD		
11 Overall length (A) mm 450,00			63 Display language Russian		
12 Overall height (B) mm 490,00			64 Engineering units Metric		
13 Weight kg 130			65 Output and Signal Configuration - Signal processing unit		
14 Flow range m³/h 32 ... 2500			66 <i>DO0/AO0 Terminals 31/32 (HF-Pulse)</i> Volume a.c., no pulses when data invalid		
15 Number of meas. paths 4			67 Signal configuration NAMUR / normally open		
16 Linearity +/- 0.5% of MV 0.1 ... 1 Qmax			68		
17 * Repeatability < 0,1%			69		
18 Flange design code DIN/EN 1092-1			70		
19 Flange class PN100			71		
20 Flange face Form B2			72 <i>MOD Terminals 33/34 (RS 485)</i> SICK Modbus ASCII		
21 Body material 1.0566 / ASTM A350 Gr. LF2			73 <i>DO1 Terminals 51/52 (HF-Pulse)</i> Volume a.c.		
22 Transducers exchangeable under pressure No			74 meter factor 1/m³ 2.880		
23 * Transducer cover Aluminium			75 Signal configuration NAMUR / normally open		
* 24 Design temperature °C -46 ... 100			76 max. Output 8,2 V / 0,8...6,5 mA		
* 25 Design pressure bar (g) 94			77 <i>DO2 Terminals 41/42 (Status)</i> Status Warning		
26 Material certificate 3.1 EN 10204			78 Signal configuration NAMUR / normally open		
27 * Enclosure classification IP 67			79 max. Output 8,2 V / 0,8...6,5 mA		
28 * Surface coating / painting two layers: Epoxy + Acrylic RAL9002			80 <i>DO3 Terminals 81/82 (RS 485)</i> SICK Modbus ASCII		
29 * Pressure tapping 1/4" NPT female			81		
30 Sensors			82		
31			83 COMMUNICATION		
32 * Sensor material Titan 3.7165			84 Interface 2x RS 485		

4.5.1 **Disconnecting from the meter and closing the session**

When disconnecting from the meter, a session is stored in the FLOWgate™ meter database. It contains the following data:

- a complete parameter set from the meter at disconnection
- all parameter changes made during Field setup (entries can be viewed in the Meter Explorer)
- all logbook data (if downloaded)
- the Maintenance Report created on page 8 of the Field setup

This data can be accessed later with the "Session Browser", even when you are not directly connected to the meter.

To disconnect from the meter and to close the session, proceed as follows:

- ▶ Use disconnect/connect button from fast access bar or close the device tab.
- ▶ If not disabled, FLOWgate™ asks for a Session name that can describe the session purpose.
- ▶ Otherwise a default name is used. This setting can be changed in the Application Settings at "Misc" tab. In a session all changed parameters will be stored.

4.6 **Function test**

The major system parameters are configured at the factory. The default settings should allow error free operation of the FLOWSIC600. Nevertheless, correct meter operation should be verified on site when the meter is installed and is subject to actual operating conditions.

4.6.1 **Function test on FLOWSIC600 with LCD front panel**

The FLOWSIC600 is functioning correctly, if the standard display shows two pages of measurands and current readings and the pages alternate every 5 seconds. If a current error or warning is active, the display will be interrupted by an error message every 2 seconds. As soon as the cause of the error/warning has been rectified, the FLOWSIC600 automatically returns to the standard display.

If the logbooks contain unacknowledged errors, warnings or information, the corresponding letter is displayed in the upper right hand corner and flashes. The letter stops flashing, once the message has been acknowledged in the logbook. It disappears when the entries have been cleared from the logbook.

 You are advised to check the plausibility of the measured and diagnosis values, even if the device is functioning properly (see chapter → »Maintenance«).

4.6.2 **Function test on FLOWSIC600 with LED front panel**

The FLOWSIC600 is functioning correctly when the green status LEDs for each measuring path installed start flashing periodically approximately 30 seconds after the power supply is switched on.

If the yellow LED flashes, the FLOWSIC600 works in the operation state "Check request" with an insignificantly reduced accuracy (e.g. if one path fails).

If the yellow LED lights up permanently, the measurement is invalid. In this case, the error must be diagnosed (see Chapter 8 of this Manual).

4.6.3 Function test with FLOWgate™

Performance check

- ▶ Once the facility is flowing at the initial flow rate, go to the "Meter values" page to check the performance of the meter. The performance value should be at least 75% on all paths. If the velocity of gas is greater than 30 m/s (100 ft/s), the performance values may be significantly lower.
- ▶ Check the Main system bar for system alarms (the device status bar should be green) and warnings (the device status bar should be green) (→ Figure 26). If there is a yellow or a red symbol, proceed as described on → pg. 94, 6.1.

Zero phase check

- ▶ Use the "Path Diagnosis" wizard in the "Diagnostics" menu (→ Figure 26) to check the "Zero Phase" parameters of both transducers on each path.

Properly adjusted zero phases of the individual paths are the basis for accurate transit time measurement of the ultrasonic signals. The "Zero Phase" parameter of a path is properly adjusted, when the Zerophase line is in the middle of the runtime plausible range and the runtime symbol (diamond) is positioned exactly on the second positive zero crossing of the received ultrasonic signal (→ Figure 27).

Figure 26 "Path Diagnosis" wizard in FLOWgate™

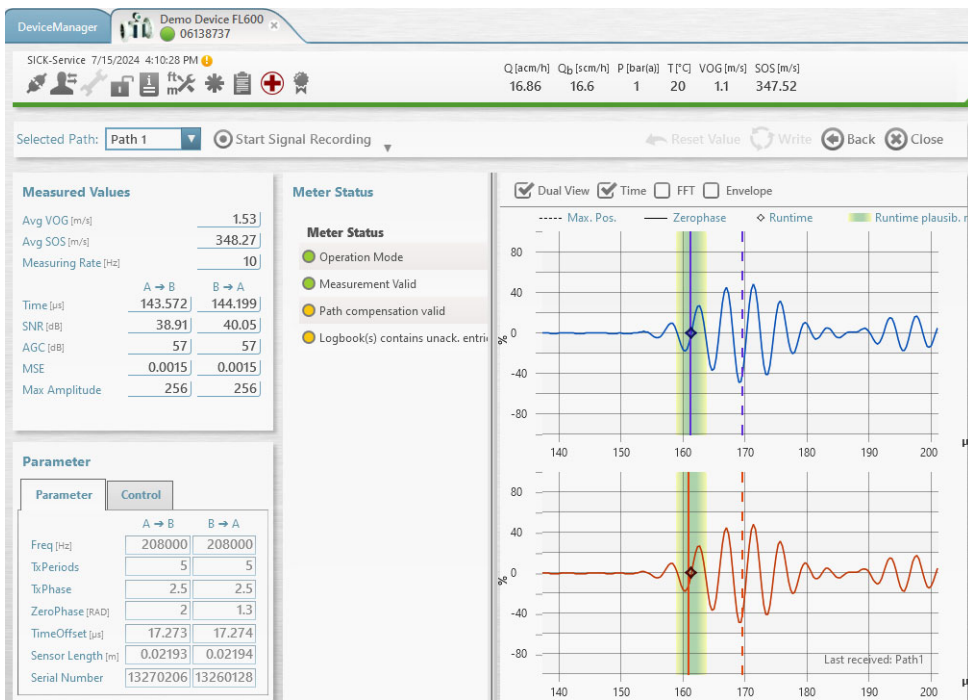

In addition, the validity of the settings should be verified:

- ▶ Open the "Status Diagnostics" in the "Diagnostics" menu and go to the window and go to the tab "Advanced or Path Status" (→ pg. 80, Figure 33). If a lamp for "Time plausibility" is on, it indicates an incorrect zero phase.

Figure 27 Signal window displaying ultrasonic signal in the "Path Diagnosis" page

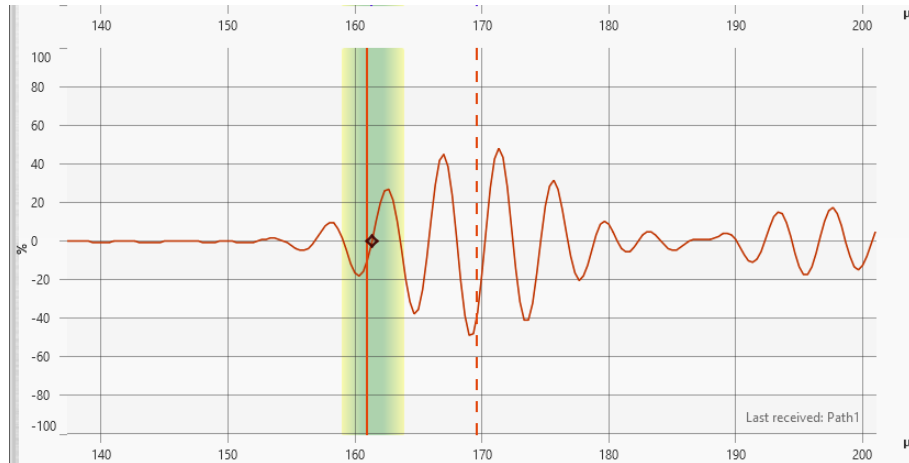

- ▶ Go to the "Meter values" page to check that the measured SOS values are almost the same at all paths of the FLOWSIC600, and that they differ by less than 0.1% (→ Figure 28).
- ▶ Switch between display of absolute and difference SOS by clicking the tab below the SOS diagramm..



In the case of very low gas velocities (< 1 m/s or 3 ft/s), there may be more significant differences between the paths due to thermal stratification. In this case, the SOS on the upper paths (1 and 2) will be higher than the lower paths.

- ▶ Check that the measured SOS deviates no more than 0,3% from a theoretical SOS, which is calculated from gas composition, pressure and temperature (→ pg. 83, 5.2.1).

Figure 28 SOS per path on the "Meter values" page (left: absolute SOS , right: difference to average)

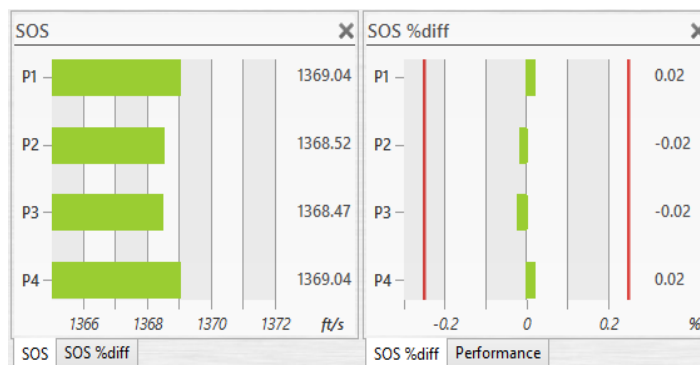

4.7 **Optional advanced setup**

4.7.1 **Configuration and activation of User Warnings**

When normal operating conditions have been reached, the User Warnings can be configured to best suit the specific application.

 • The User Warnings are preconfigured when the meter is shipped from the factory.

• If there is no need to change the User Warnings, or if you are not sure about consequences of changes, keep the values as they are or discuss with a Endress+Hauser representative.

To configure the User Warning limits, proceed as follows:

- ▶ Use FLOWgate™ to connect to the meter (→ pg. 61, 4.3).
- ▶ Open the "User Warnings" assistant from the "Diagnostics" menu.
- ▶ Use the tabs to set "System/Profile" warnings, "Path warnings" or the "Diagnostic comparison".
- ▶ Activate or deactivate User Warnings with the check box on the right.
- ▶ Edit parameter values in the fields.
- ▶ Click the "Write to meter" button.

 All User Warning parameters - except for the parameter 'Min. VOG for warnings' - can be configured in the User Access Level "Operator" and without switching the meter to the Configuration Mode.

Figure 29 "System Warnings" page

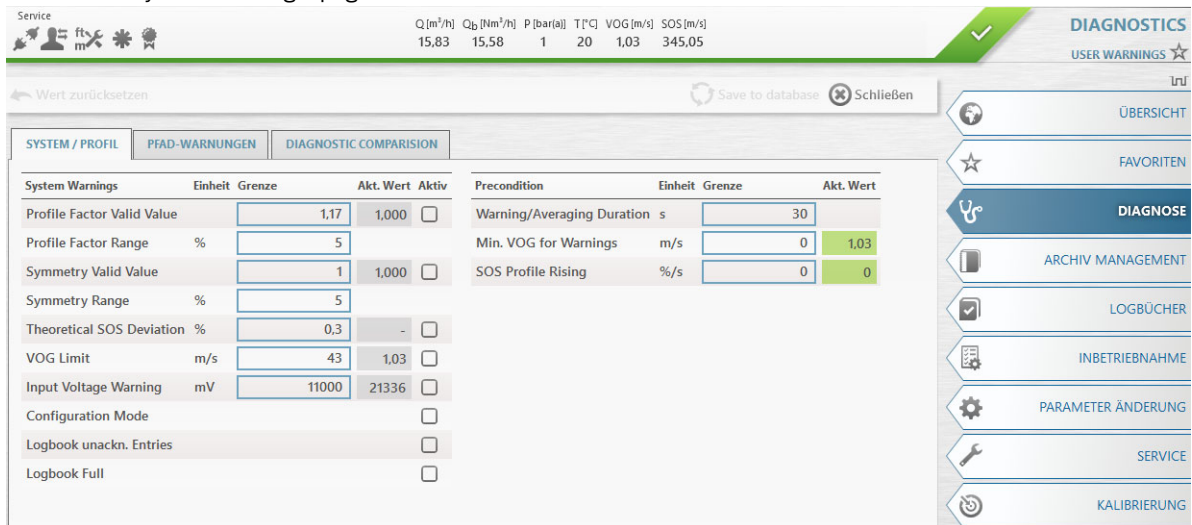
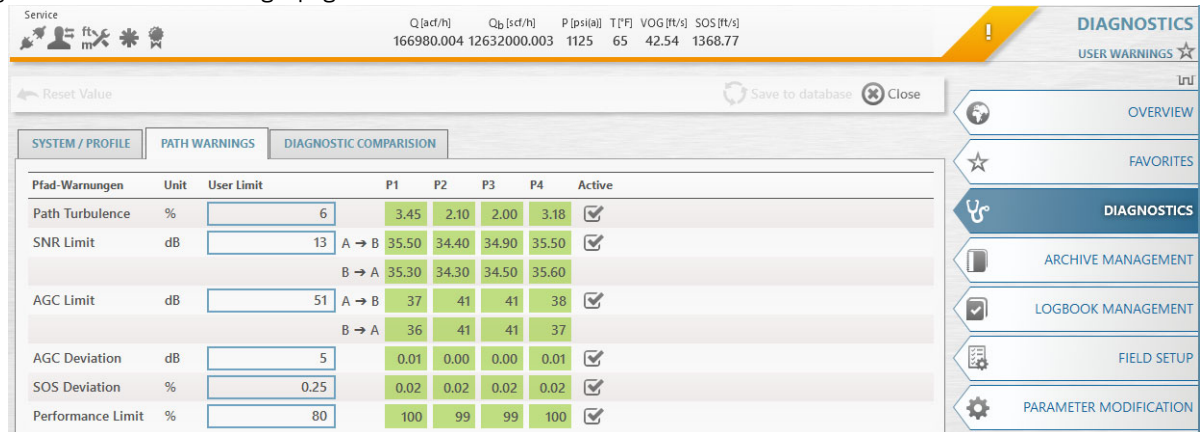

Figure 30 "Path Warnings" page



4.7.2 Configuration of DataLogs

4.7.2.1 Using the DataLogs

Starting with firmware version 3.4.00, the FLOWsIC600 provides two DataLogs (Hourly Log and Daily Log). They save averaged measured values and are stored in the SPU's non-volatile memory (FRAM). All data can be downloaded and exported to Excel files with FLOWgate™ (→ pg. 24, 2.4.4.).



Valid flow for DataLog logging

Gas flow values are averaged for the DataLog entry only if VOG is above the "Min. VOG for warnings" (→ pg. 72, 4.7.1) and the flow is in the direction for which the DataLog was configured. The Flow Time saved for every entry indicates about how long the gas flow was valid for DataLog Logging during the storage cycle. For example:

- If the flow was above "Min. VOG for warnings" and in the forward direction (for a forward configured Hourly Log) for half an hour, the corresponding Hourly Log data will show a Flow Time of 50%.
- If the flow was above "Min. VOG for warnings" but in the reverse direction (for a forward configured Hourly Log) for an hour, the corresponding Hourly Log data will show a Flow Time of 0%.
- If the Flow Time is 0%, all diagnosis related values are shown as 0 (Temperature is 0 Kelvin). Meter Status and Volume Counter values are shown as usual.

4.7.2.2 **Configuration of DataLogs**

The following parameters can be configured in the "Archive/Logbook" window at "Parameter Modification" menu. (→ Figure 31) to best suit the specific application (for more details see → pg. 23, 2.4.3.4 and following):

- Type of dataset,
- Storage cycle,
- Storage behavior,
- Active flow direction,
- Accounting hour
- Distribution of FRAM capacity.

 Changes to the parameters "Type of dataset", "Storage behavior" or "Direction" will erase all entries from the DataLog which is changed.

▶ If configuring these parameters after commissioning, first download and export all entries according to → 2.4.4, to prevent loss of data.

When the meter is shipped, the DataLogs are preconfigured.

Table 4 Standard DataLogs configuration when meter is shipped *

Configuration parameter	Hourly log	Daily log	Diagnostics comparison log
Type of Dataset	Diagnostic values	Volume counters	Diagnostic values
Storage cycle	1 hour	1 day	5 min
Storage behavior	Overflow	Overflow	not applicable
Active flow direction	Forward	Forward	Bidirectional
Accounting hour	not applicable	0 (midnight)	not applicable
Max. number of entries	Entries for approx. 38 days	Entries for approx. 2 years	20 entries

 * Depending on location, the DataLogs for the specific FLOWSIC600 may be preconfigured. These settings may differ from the defaults described here.

Complete the following steps to configure the DataLogs:

- ▶ Go to the "Archive/Logbook" window in "Parameter Modification" menu.
- ▶ Switch the meter into Configuration Mode (choose "configuration mode" from the quick access menu).
- ▶ Use the drop down lists to select the parameter settings.
- ▶ Click the "Write to meter" button.

Figure 31

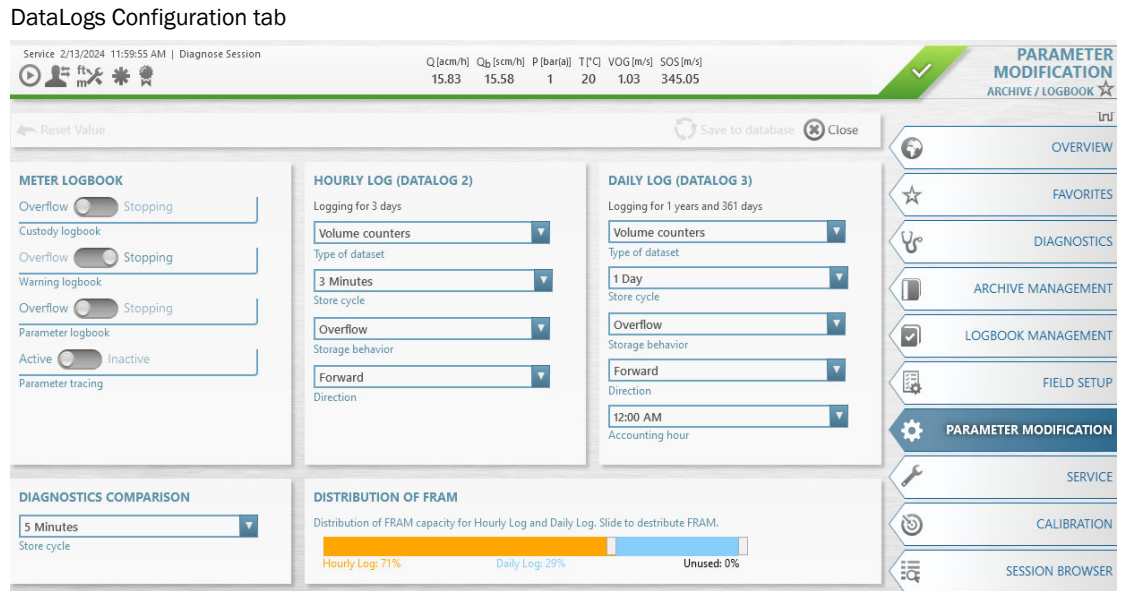

4.7.2.3 **Disabling DataLogs**

To disable a DataLog complete the following steps:

- ▶ Go to the "Archive/Logbook" window in "Parameter Modification" menu.
- ▶ Switch the meter into Configuration Mode (choose "configuration mode" from the quick access menu.).
- ▶ Set the parameter "Storage cycle" to "disabled" for any DataLog that should be disabled.
- ▶ Click the "Write to meter" button.

4.7.2.4 **Enabling (starting) DataLogs**

To enable (start) a disabled DataLog, complete the steps described under → pg. 75, 4.7.2.5 (Resetting DataLog Parameters to Defaults).

4.7.2.5 **Resetting DataLog parameters to defaults**

+i Before resetting DataLog Parameters to Defaults
 In FLOWgate™ from V1.1.00, DataLog entries are not saved in the meter database. Before clearing entries from DataLogs, download and export the entries into Excel (→ pg. 90, 5.4.2).

Complete the following steps to reset the DataLog parameters to the defaults:

- ▶ Go to the DataLogs page (select Meter / DataLogs from menu).
- ▶ Choose the "Configuration" tab (see → Figure 31).

- ▶ Switch the meter into Configuration Mode (choose "configuration mode" from the quick access menu).
- ▶ Click "Reset defaults".

**Defaults**

The default settings are described in → 2.4.3.1 and → 2.4.3.2.

4.7.3 **Configuring and using the Diagnostics Comparison Log**

The Diagnostics Comparison Log can be used to get information on changes in the meter's health (more information → pg. 24, 2.4.4): The Diagnostic Comparison Report, created from the data of the Diagnostics Comparison Log, facilitates an easy and quick information about changes in the meter health between two different points of time (e.g. commissioning and now).

4.7.3.1 **Using the Diagnostics Comparison Log**

The Diagnostics Comparison Log provides a comparison between current diagnostic values and those of a reference time (e.g. at time of commissioning). The current diagnosis values are stored in Current Classes 1 to 5, while the reference values are stored in Reference Classes 1 to 5.

To prepare the Diagnostics Comparison Log for the future use, complete the following steps when the FLOWSIC600 is running under normal operating conditions:

- ▶ Go to the "DataLogs" page (choose "Meter / DataLogs" from the menu) → pg. 75, Figure 31.
- ▶ In the "DataLog" selection dialog, activate the check box for "Diagnostics Comparison" [DataLog1], to download the Diagnostics Comparison data from the meter.
- ▶ Click "Export Datalogs" and export the Diagnostics Comparison Data to an Excel File for future reference.
- ▶ Clear all Diagnostics Comparison Log data that may have been collected from the meter during calibration:
 - ▶ Choose the "Configuration" tab (see → Figure 31).
 - ▶ Switch the meter into Configuration Mode (select File/Configuration Mode from menu).
 - ▶ Click the "Clear Diagnostics Comparison" button and confirm the confirmation dialog with "Yes".
 - ▶ Switch the meter into Operation Mode.
- ▶ If possible, operate the meter in the Velocity Range Classes 1 to 5 (also see → pg. 78, 4.7.3.2) to fill the Reference Classes with data representing the correct operation of your installation.



Filling the velocity range classes with valid flow data

- Only stable gas flow conditions will be used to calculate the averaged data in the Diagnostics Comparison Log. Therefore the set gas velocities should be well within the class limits and should stay relatively stable for the time set as storage cycle (default is 5 minutes).
- The parameter DataLogClassStdev (Reg. #3050) sets the allowed standard deviation for the definition of the gas flow conditions as stable → 2.4.3.4.

When the reference classes are filled with data representing the usual operation of the installation, the current classes will be continuously updated, showing the current state of the meter.

4.7.3.2 **Configuring the general conditions for the Diagnostics Comparison Log**

The gas velocity class ranges are calculated to optimally cover the operation range of the meter. The lower limit of the gas velocity range classes is defined by the parameter "Min. VOG for warnings". The upper limit is defined by "VOG limit".

- ▶ View the Diagnostics Comparison data tab, to find the velocity class limits calculated for the meter. → Figure 4, S. 24 shows an example of a Diagnostics Comparison Log filled with entries.
- ▶ If necessary, configure "Min. VOG for warnings" and "VOG limit" to fit the application range of your specific FLOWSIC600 on the configuration tab of the User Warnings window (→ pg. 72, 4.7.1).



- Changes to the parameters "Min. VOG for warnings" or "VOG limit" (#7201 MaxVelGas) will clear all data from the Diagnostics Comparison Log!
- Note that the parameter "Min. VOG for warnings", Reg. #7208 "PathCompClassLow", plays an important role in path compensation.
- Note that the parameter "VOG limit" also defines the limit for User Warnings.

4.7.3.3 **Configuring the Diagnostics Comparison Log**

Complete the following steps to configure the Diagnostics Comparison Log:

- ▶ Go to the "Archive/Logbook" window in "Parameter Modification" menu.
- ▶ Switch the meter into Configuration Mode (select File/Configuration Mode from menu).
- ▶ Use the drop down lists behind the arrows to select the store cycle.
- ▶ Click the "Write to meter" button.

4.7.3.4 **Configuration of the Diagnostics Comparison limits**

The Diagnostics Comparison limits can be activated to make the meter generate a warning when the difference between the diagnostic values in the reference classes and those in the current classes exceed the Diagnostics Comparison limit values.

These limits can be activated and configured in the User Warnings window:

- ▶ Use FLOWgate™ to connect to the meter (→ pg. 61, 4.3).
- ▶ Open the "User Warnings" window from the "Diagnostics" menu.
- ▶ Go to the "Diagnostic Comparison limits" tab (→ Figure 32).
- ▶ Activate or deactivate the Diagnostic Comparison limits with the check box on the right.
- ▶ Edit parameter values in the fields.
- ▶ Click the "Write to meter" button.



All Diagnostics Comparison limit parameters can be configured in the User Access Level "Authorized Operator" and without switching the meter to the Configuration Mode.

Table 5 Diagnostics Comparison limits

Monitored difference between reference values and current values	Configurable difference limit	Default value	Notes	Default activation state ¹
Profile factor	Profile Factor change	10%	A change of the profile factor value may be caused by contamination, blockage or deposits in the line that change the symmetry of the flow profile. ▶ We recommend to use the default value.	Off
Symmetry	Symmetry change	10%	A change of the symmetry value may be caused by contamination, blockage or deposits in the line that change the symmetry of the flow profile. ▶ We recommend to use the default value.	
SOS differences between paths	SOS difference change	1%	The SOS deviation indicates whether or not a path is measuring the correct transit time. ▶ We recommend to use the default value.	
Turbulence	Turbulence change	50%	A change of the turbulence value may be caused by contamination, blockage or deposits in the line that change the symmetry of the flow profile. ▶ We recommend to use the default value.	
SNR (Signal-to-noise ratio)	SNR change	20dB	Interfering noise caused by fittings in the pipeline, valves that are not fully open, sources of noise near the measuring location, or defective ultrasonic transducers may affect the signal-to-noise-ratio. ▶ We recommend to use the default value.	
AGC (Signal amplification)	AGC change	10dB	If the AGCs of a path deviate more than allowed, this can indicate a malfunction in the ultrasonic transducers, electronic modules, transducer cables or parameter settings (signal models, control limits). ▶ We recommend to use the default value.	

¹ User Warnings must be activated to become effective on the warning output.

Figure 32 "User Warnings" window with "Diagnostics Comparison limit" tab

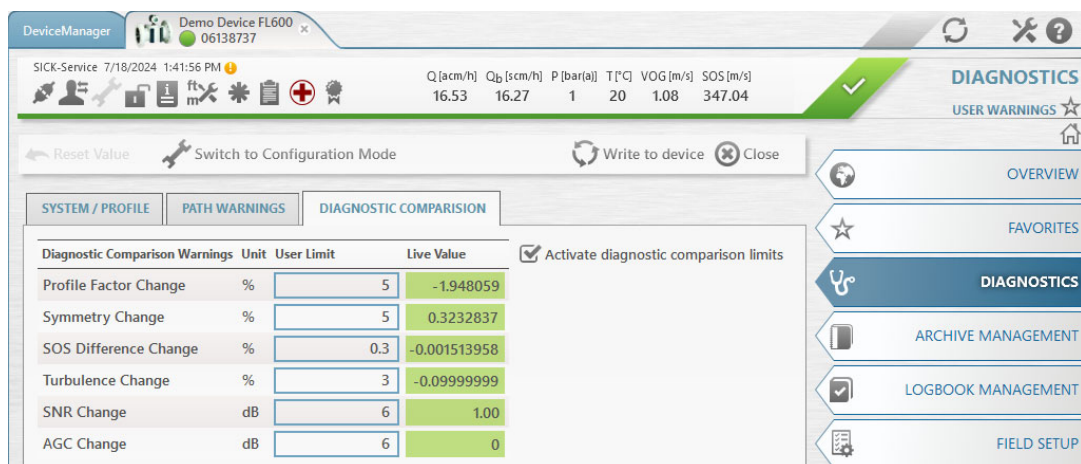

4.8 Activation of path compensation

If the status bit "Path compensation valid" is "active", then the FLOWSIC600 is able to compensate a path failure-

The meter automatically sets this bit to "active" after operating for about 20 minutes with error free measurement at all paths at a gas velocity between 1 to 8m/s (3.3 to 26.2 ft/s) and also about 20 minutes at a gas velocity higher than 8m/s (26.2 ft/s).

The status bit "Path compensation valid" is displayed on the "Meter status" page (→ pg. 80, Figure 33).

+i Determination of path relationships during commissioning

Due to the unique path relationships of each individual installation, every meter must determine the path relationships during the commissioning procedure.

In order to ensure that the system is able to compensate for path failure at both high and low flow velocities, it is recommended that the FLOWSIC600 meter be run for 20 minutes at low gas velocities (< 8 m/s or < 26.2 ft/s) first and then for 20 minutes at high gas velocities (> 8 m/s or > 26.2 ft/s) during commissioning.

Figure 33 "Meter status" page with active "Path compensation valid" status bit

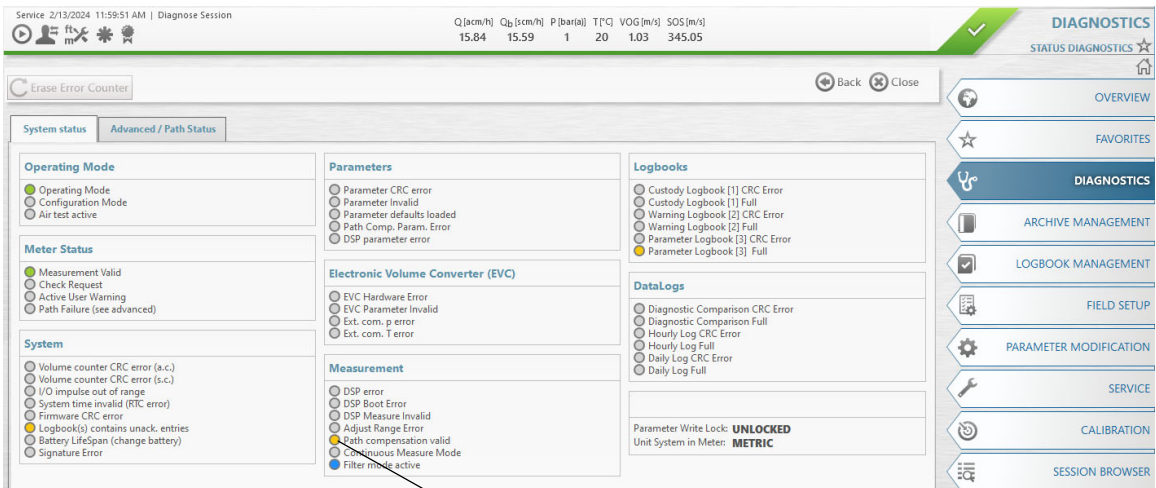

"Path compensation valid"

4.8.1 Sealing

After having completed the commissioning, seal the signal processing unit (if required) in accordance with the sealing plan (→ pg. 151, 7.9).

4.9 Documentation

The commissioning should be documented with a Commissioning Protocol. File the completed Commissioning Protocol with the Manufacturer Data Record (MDR)

- It is recommended to backup device parameters with a diagnostic session or a device export after commissioning.

FLOWSIC600

5 Maintenance

- General
- Routine checks
- Maintenance report
- Optional data download

5.1

General

The FLOWSIC600 does not contain mechanically moving parts. The meter body and ultrasonic transducers are the only components that come into contact with the gaseous media. Titanium and high-quality stainless steel ensure that these components are resistant to corrosion, provided that the meter is installed and operated in accordance with the relevant specifications. This means that the FLOWSIC600 is a low-maintenance system. User Warning Limits can be configured to provide early warnings for possible issues with contamination or blockage. Maintenance is limited mainly to routine checks to determine the plausibility of the measured values and diagnostic results produced by the system.

It is recommended that Maintenance Reports be created and filed on a regular basis (→ pg. 87, 5.3). This creates a basis of comparable data over time and helps when a problem requires diagnosis.



The operating conditions (gas composition, pressure, temperature, flow velocity) of the individual Maintenance Reports should be comparable or documented separately and taken into account when the data is analyzed.

Routine checks:

- »Comparing theoretical and measured Speed of Sound (SOS)« (pg. 83)
- »Checking the meter health« (pg. 84)
- »Time synchronization« (pg. 85)
- »Battery lifespan / capacity« (pg. 86)

Documentation:

- »Maintenance report« (pg. 87)

Optional data download:

- »Logbook check« (pg. 88)
- »DataLogs check« (pg. 90)

5.2 **Routine checks**

The information displayed on the front panel LCD display of the FLOWsIC600 meter can be checked to ensure that the system is functioning properly. The FLOWgate™ software provides a more user friendly way for doing routine checks.

5.2.1 **Comparing theoretical and measured Speed of Sound (SOS)**

One of the most important criteria for the correct operation of an ultrasonic gas meter is the consistency between the theoretical SOS, calculated for the actual gas composition, temperature and pressure, and the SOS measured by the ultrasonic gas meter.

The Speed of Sound Calculator (SOS Calculator) available in FLOWgate™ calculates a theoretical SOS for a specific gas composition at a specified temperature and pressure (→ Figure 34). The calculation of thermodynamic properties is based on the "GERG-2004 XT08 Wide-Range Equation of State for Natural Gases and other Mixtures". The algorithms that are implemented in the SOS calculator were developed by the Ruhr-University Bochum (Germany).

Figure 34 Speed of Sound Calculator with loaded gas composition file

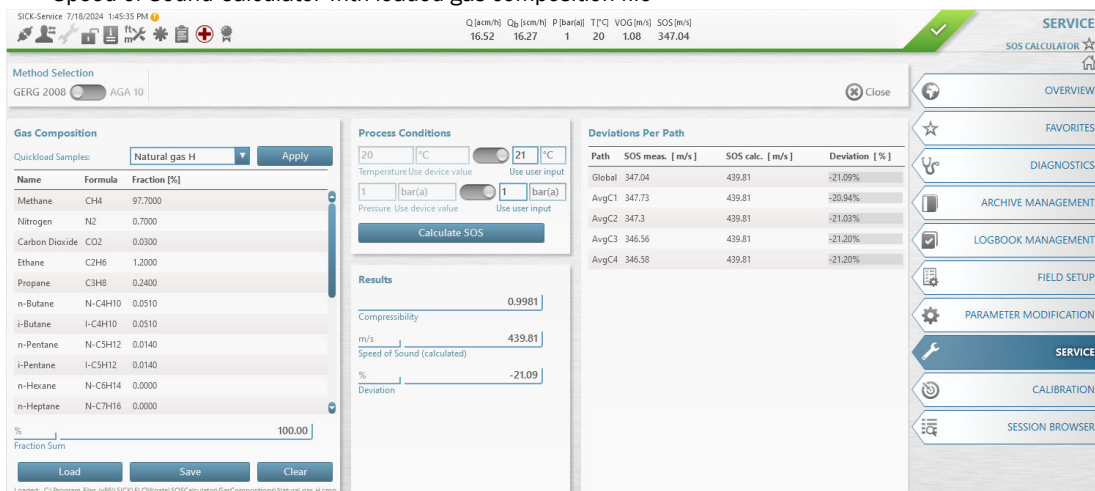

- ▶ Use FLOWgate™ to connect to the meter (→ pg. 61, 4.3).
- ▶ Start the SOS calculator from the "Service menu".
- ▶ Enter the gas composition and specify temperature and pressure for your specific application.
- ▶ Click the "Calculate" button.
- ▶ If the SOS calculator was started from the Maintenance Report, the calculated value is automatically copied to the corresponding field in the wizard and to the report.
- ▶ Compare the theoretical SOS with the SOS measured by the FLOWsIC600 (see Figure 35, main system bar).

The deviation between both should be less than 0.1%. If the deviation exceeds 0.3%, check the plausibility of temperature, pressure and gas composition. Otherwise proceed according to → pg. 83, 5.2.1.

It is possible to set up a user warning to continuously monitor for a deviation between a theoretical SOS (written to the meter e.g. by a flow computer) and the current measured SOS. See -> Section Commissioning, Optional setup of user warnings.

5.2.2 **Checking the meter health**

The FLOWSIC600 monitors its own meter health with User Warnings and system alarms. If the outputs are configured to indicate alarms and / or User Warnings, it is not necessary to manually check the meter health.

To get visual feedback about the meter's health, the "Main system bar" in FLOWgate™ provides a compact overview:

- ▶ Use FLOWgate™ to connect to the meter (→ pg. 61, 4.3).
- ▶ Check the device status bar. A yellow or red colour indicates a potential problem with the meter.

If the device status is not green proceed with checking the "Status diagnostics" and "user warnings".

Figure 35 Main system bar

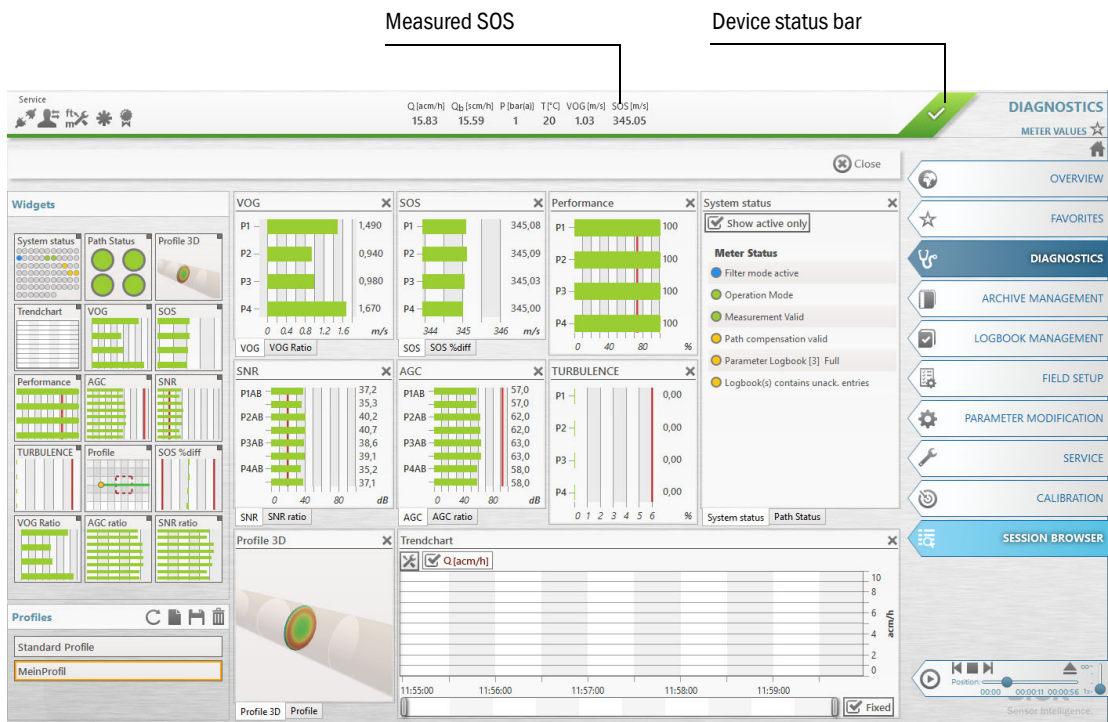

5.2.3 **Time synchronization**

All entries in logbooks or datalogs saved in the meter’s memory (FRAM) are written with a time stamp containing the meter time. The meter time can be synchronized with a master clock (e.g. PC clock) via MODBUS or with FLOWgate™.

+i A synchronization causes a logbook entry in the Custody logbook [1] only if the time change is greater than 3% of the time elapsed since the last synchronization.

Synchronization via MODBUS

The date and the time of the FLOWsic600 can be set separately by an external write. Each operation for date and time causes a separate entry in the Custody logbook [1].

Alternatively the synchronization function can be used. To use this method, the date (Reg. #5007 "Date") and the time register (Reg. #5008 "Time") must be written sequentially within 2 seconds. The date register must be written first. The write operation can be accomplished by the MODBUS without setting the FLOWsic600 into Configuration Mode.

Time synchronization via FLOWgate™

FLOWgate™ offers a synchronization function in "Parameter Modification" menu. The time can be synchronized and the Display configured in the "System+LCD" window.

Figure 36

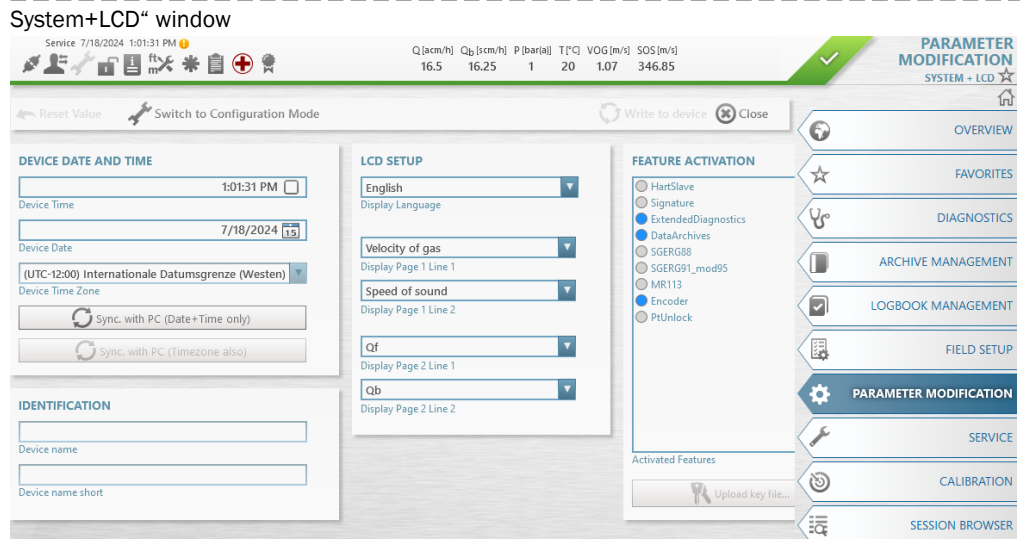

5.2.4 Battery lifespan / capacity

The Real Time Clock (RTC) of the FLOWSIC600 is buffered by a battery. The manufacturer states that the battery life span is at least ten years. The remaining battery capacity can be viewed on the LCD in the first menu level .

Figure 37 Display of remaining battery capacity on the LCD display

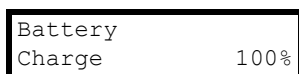

Because the FLOWSIC600 has no regular maintenance cycle, the system alarm "Battery lifetime" is generated when the remaining battery life is less than 15%. This alarm forces the operator to change the battery (→ pg. 95, 6.2.1). A logbook entry is also generated.



NOTICE:

The battery may only be changed by trained staff. See → pg. 99, 6.2.4 for troubleshooting.

5.3 **Maintenance report**

It is advisable to regularly create and archive a Maintenance report. This serves to create a comparison database and supports diagnostics.

+i The operating conditions (gas composition, pressure, temperature, flow velocity) of the individual Maintenance Reports should be similar. When the individual reports are compared, it is recommended to evaluate and document deviations.

- ▶ Click on “Create Status Report” (clipboard icon) in the Status bar.
- ▶ The “Maintenance Report” dialog opens.
It is recommended to set the duration of data collection to 5 minutes, but it can also be changed in the selection list.

Figure 38

Status Report

Maintenance Report

Report Name

Description

Technician

Duration of Data Collection

m/s SOS SOS Calculator

Calculated SOS

Temperature °C Use device value °C Use user input

Pressure bar(a) Use device value bar(a) Use user input

Last log date [aa]

- ▶ After the end of data collection, the report opens automatically and can be printed, saved as PDF document or sent via e-mail.
- ▶ Finally close the report with the “Close” button.
- ▶ It is recommended to file the printed report with the device delivery documentation.

5.4 **Optional data download**

5.4.1 **Logbook check**

 To prevent an overflow of the logbooks and possible data loss, logbook entries can be saved to the meter database with the FLOWgate™ operating software. The entries on the meter can then be deleted.

Logbook check and data backup

Menu “Logbooks” provides an overview and a general introduction to the logbooks. The following functions are available here:

- Reading the respective logbooks from the device.
- Loading the respective logbooks from the database.
- Acknowledging entries.
- Deleting logbooks in the device or in the data base.
- Outputting logbooks as CSV file.
- Outputting a report of the respective logbook.

Checking the data archives (data logs)

The FLOWSIC600 is equipped with a Diagnostics Log, an Hourly Log and a Daily Log. The measured data archives are saved accordingly in the non-volatile memory of the device.

Menu “Archive Management” provides an overview and a general introduction to the logbooks.

The following functions are available here:

- Reading the respective archive from the device.
- Loading the respective archive from the database.
- Deleting entries.
- Deleting archive in the device or in the data base.
- Outputting archive as CSV file.
- Outputting a report of the respective archive.

Figure 39 "Meter logbook" page in FLOWgate™

	All	Unack.	Max
Total	0	0	0
Information	0	0	----
Warning	0	0	----
Error	0	0	----

Datum/Zeit	Quittiert	Gruppe	Zustand	Beschreibung	Daten	+V[m ³]	+Verr[m ³]	-V[m ³]	-Verr[m ³]
19.07.2018 10:59:31	✓	I	✓	Warnungslogbuch gelöscht	Letzte Zahlwerksänderung: 19.07.2018 10:59:30	180540	40820	13510	420
19.07.2018 11:02:19	✓	I		Nutzerwarnung überschritten	Maske: 00000000	181160	41950	13510	420
19.07.2018 13:01:04	✓	I	✓	Nutzerwarnung überschritten	Maske: 00000010	182000	41950	13510	420
19.07.2018 13:01:07	✓	I		Nutzerwarnung überschritten	Maske: 00000000	182030	41950	13510	420
19.07.2018 13:11:33	✓	I	✓	Nutzerwarnung überschritten	Maske: 00000010	182710	41950	13510	420
19.07.2018 13:12:11	✓	I		Nutzerwarnung überschritten	Maske: 00000000	183060	41950	13510	420

5.4.1.1 **Downloading and saving logbook entries to the FLOWgate™ meter database**

To download and save logbook entries to the FLOWgate™ meter database, proceed as follows:

- ▶ Use FLOWgate™ to connect to the meter (→ pg. 61, 4.3).
- ▶ Choose "Meter / Meter Logbook" from the menu to open the Logbook page.
- ▶ In the dialog "Logbook selection", select the desired logbooks and click "OK".

The logbook entries are now downloaded to the FLOWgate™ database. They can be viewed offline without connection to the meter or share them with others (export the device or the session).

5.4.1.2 **Acknowledging logbook entries on the meter**

To acknowledge logbook entries on the meter, proceed as follows:

- ▶ Download and save the logbook entries from the meter according to → 5.4.1.1.
- ▶ Select the logbook in which entries are to be acknowledged or select "All logbooks" to acknowledge entries in all logbooks at once.
- ▶ Mark the entries to be acknowledged.
- ▶ Click the "Acknowledge selection" button to acknowledge the selected entries only or click the "Acknowledge all" button in order to acknowledge all entries in the selected logbook(s).

5.4.1.3 **Clearing logbooks on the meter**

If the logbooks are configured with the storage behavior "rolling", it is not necessary to clear the logbooks on the meter. When the logbook is full, new entries will overwrite the oldest entries.

If a logbook is configured with the storage behavior "blocking" (e.g. with custody configuration), a full Custody logbook [1] will activate the meter status "Data invalid". In this case it is recommended to clear the logbooks.

 **NOTICE:**

The following preconditions must be met to clear logbooks on the meter:

- The Parameter write lock must be in the "UNLOCKED" position.
- The user must be in the User Access Level "Service" (password see Service Manual).
- The meter must be in Configuration Mode.

To clear the logbooks on the meter, proceed as follows:

- ▶ Choose the User Access Level "Service" (→ pg. 61, 4.3.2).
- ▶ Download and save the logbook entries from the meter according to → 5.4.1.1.
- ▶ Select the logbook to be cleared or select "All logbooks" to clear all.
- ▶ Switch the meter to Configuration Mode (choose "File / Configuration Mode" from the menu).
- ▶ Click the "Clear meter logbook" button and confirm the warning with "OK".
- ▶ Switch the meter to Operation Mode.
- ▶ If the Parameter write lock was unlocked prior to clearing the meter logbook, follow all necessary procedures to bring the meter to back to its original state.

5.4.2 **DataLogs check**

Starting with firmware version 3.4.00, the FLOWSIC600 provides two DataLogs (Hourly Log and Daily Log). They save averaged measured values and are stored in the SPU's non-volatile memory (FRAM). All data can be downloaded and exported to Excel files with FLOWgate™ (→ pg. 73, on configuring the DataLogs.).

 Full support for the DataLogs is provided by FLOWgate™ or higher.

Figure 40 DataLogs page with opened tab for Hourly Logs



5.4.2.1 **Downloading and exporting of DataLog data**

To download and export the data from your FLOWSIC600, complete the following steps:

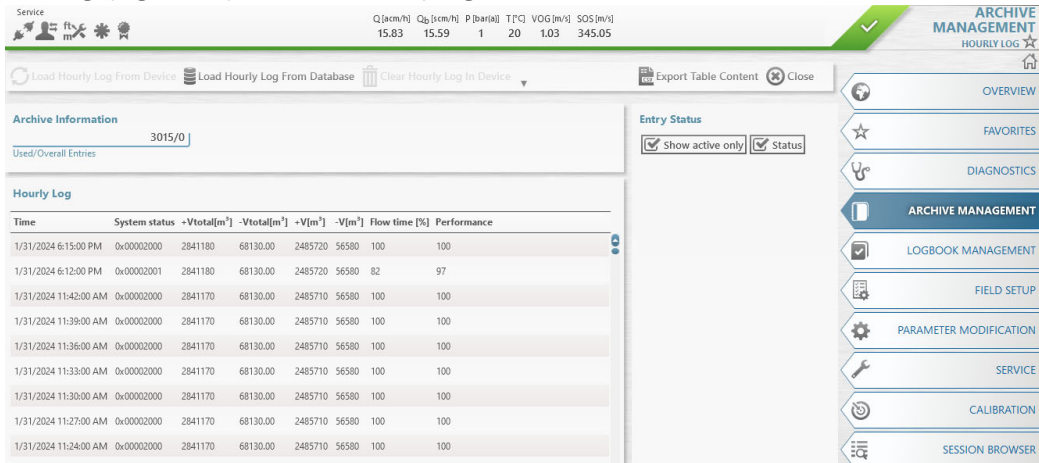
- ▶ Use FLOWgate™ to connect to the meter (→ pg. 61, 4.3).
- ▶ Go to the DataLogs page (choose "Meter / DataLogs" from the menu).
- ▶ In the dialog "DataLog selection", select those DataLogs that you want to view and/or export and click "OK".
- ▶ Now the DataLogs page is displayed with the data from the meter.
- ▶ If you select a DataLog entry, its time stamp and the meter status (see below) is shown in the middle section.
- ▶ To update the data from the meter, use the button "Read DataLogs".
- ▶ To export DataLog data to an Excel file (.xls), use the button "Export DataLogs".



Meter status

In every DataLog entry, a condensed meter status information is saved. It shows all meter status information that became active during the storage cycle - even if it was for the shortest period of time.

If a meter status information bit is shown active in a DataLog entry, the logbooks will contain a corresponding entry with more information.

- ▶ Always check the logbooks, if you require more information about the meter status information in the DataLogs.

Flow weighted diagnostic information in DataLog data

The datasets do not contain any diagnostic information for gas velocities below the value for the parameter Vmin (Reg. #7036 "LowFlowCutOff"). The "Flow time" value shows, for what percentage of the duration of the storage cycle the flow was above Vmin and in the flow direction specified for the DataLog.

All diagnostic information is flow-weighted.

5.4.2.2 **Clearing entries from DataLogs**

If the DataLogs are configured with the storage behavior "rolling", it is not necessary to clear the entries from the DataLogs on the meter. When the DataLog is full, new entries will overwrite the oldest entries.

If a DataLog is configured with the storage behavior "blocking", the DataLog will stop saving new entries when it is full and a yellow light will indicate the full DataLog on the meter status table (→ pg. 95, 6.2.1). In this case it is recommended to clear the entries from the DataLogs.

To clear all entries from a DataLog, complete the following steps:

- ▶ Go to the DataLogs page (select Meter / DataLogs from menu).
- ▶ Choose the Configuration tab.
- ▶ Switch the meter into Configuration Mode (choose "File / Configuration Mode" from the menu).
- ▶ Click the "Clear" button for the DataLogs from which you want to clear entries.
- ▶ Switch the meter into Operation Mode.

FLOWSIC600

6 Troubleshooting

General troubleshooting

Indication of meter states, system alarms and warnings

Creating a diagnostic session with FLOWgate™

Meter connection troubleshooting

This chapter provides solutions for problems highlighted by routine tests during maintenance (→ pg. 83, 5.2) or the function tests after commissioning (→ pg. 69, 4.6).

If the cause of the problem cannot be localized, it is recommended to use the FLOWgate™ software to record the current parameter set and diagnosis values in a diagnosis session file (→ pg. 99, 6.3) and send this to a local Endress+Hauser representative.

6.1 **General troubleshooting**

Problem	Possible causes	Actions
<ul style="list-style-type: none"> ● No display ● No pulse frequency ● No active status signal 	Faulty power supply	<ul style="list-style-type: none"> ▶ Check the input voltage at terminals 1 and 2. ▶ Check cables and terminal connections. <p>Caution Take the relevant safety precautions!</p>
	Defective device	<ul style="list-style-type: none"> ▶ Create a diagnosis session according to → pg. 99, 6.3 and contact your local Endress+Hauser representative.

6.2 **Indication of meter states, system alarms and warnings**

The FLOWIC600 gives information about alarms and warnings in the following ways:

- The LCD display indicates active system alarms or warnings. If a current error or warning is active, the display will flash and a message will be displayed with a message number in the upper right corner (→ pg. 137, 7.5.1 for more details on LCD error messages).
- A status output can be configured to indicate if the meter status "Data invalid", the meter status "Check request" or the "Warning" status become active.
- The pulse output can be configured to indicate if the meter is in Configuration Mode or if the meter status "Data invalid" becomes active.
- The meter status registers can be read via MODBUS (see document "FLAWSIC600 Modbus Specification").
- The FLOWgate™ software can be used to check the meter health. System alarms and User Warnings are indicated in the Main system bar.

It is recommended to use FLOWgate™ to get further information on the meter's health:

- ▶ If the meter indicates "Data invalid" or "Check request" follow → pg. 95, 6.2.1.
- ▶ If the meter indicates "Warning", follow → pg. 97, 6.2.2.

6.2.1 **Checking the "Meter Status" window**

The "Status diagnostics" window in FLOWgate™ displays an overview about the meter's status and operation.

- ▶ Use FLOWgate™ to connect to the meter (→ pg. 61, 4.3).
- ▶ Click on the "Status diagnostics" window in the "Diagnostics" menu or click on the meter status bar symbol. (→ Figure 41).
- ▶ Check the general "System status" and "Path status" section (marked in Figure 41) for yellow or red lights.

Meter status light	Causes	Actions
Green light "Measurement valid"		Measurement is valid, meter is operating correctly.
Red light "Measurement valid"	Measurement is invalid and / or the meter is in Configuration Mode. The measured volume is counted in the error volume counter. ¹	<ul style="list-style-type: none"> ▶ If the meter is in Configuration Mode, choose "File / Operation Mode" from the menu to switch it to Operation Mode. ▶ Otherwise proceed according to → pg. 99, 6.3.
Yellow light "Check request"	One or more paths have failed or another problem affects the measurement accuracy. ¹	▶ Proceed according to → pg. 99, 6.3.
Yellow light "User Warning Limit exceeded".	A User Warning Limit was exceeded. ²	▶ Check the User Warnings according to → pg. 97, 6.2.2.
Red light "Path failure"	One or more paths have failed.	▶ Proceed according to → pg. 99, 6.3.

¹ See → pg. 17, 2.2.2 for more details on meter states.

² See → pg. 20, 2.3 for more details on User Warnings.

- ▶ If there are no yellow or red lights in the general "Meter Status" section you can check the following other sections (also marked in Figure 41) for yellow or red lights.

Meter status light	Causes	Actions
Yellow light "Logbook contains unack. entries"	Logbook contains unacknowledged entries.	▶ Download and check all logbook entries according to → pg. 89, 5.4.1.1.
Red light for any Logbook "full"	The logbook in question is configured to "blocking" and is full of entries.	<ul style="list-style-type: none"> ▶ Download and check all logbook entries according to → pg. 89, 5.4.1.1. ▶ Clear the meter logbook according to → pg. 89, 5.4.1.3. ▶ Consider reconfiguring the logbook to "rolling" (Parameter Page). If your meter is configured according to PTB requirements a full Custody Logbook [1] will activate the meter status "Data invalid". ▶ Download and check all logbook entries according to → pg. 89, 5.4.1.1. ▶ Clear the meter logbook according to → pg. 89, 5.4.1.3.
Yellow light for any Data-Log "full"	The DataLog in question is configured to "blocking" and is full of entries.	<ul style="list-style-type: none"> ▶ Check the DataLog ▶ whether the DataLog is to be configured as "rolling" .
Yellow light "Battery Lifespan (change battery)"	After 8.5 years this warning is activated to force the user to change the battery.	<ul style="list-style-type: none"> ▶ See → pg. 99, 6.2.4 for more details. ▶ Contact trained staff or your Endress+Hauser representative. ▶ Trained staff: Change the battery according to the procedure described in the Service Manual

Figure 41 "System status" in the "Status diagnostics" window

General "Meter Status" section

Indication if logbook(s) contain(s) unacknowledged entries

Battery change

"Logbooks" section

"DataLogs" section

6.2.2 **Checking the "User Warnings" window**

The "User Warnings" window displays an overview about the User Warning status.

- ▶ Use FLOWgate™ to connect to the meter (→ pg. 61, 4.3).
- ▶ Click on the "Meter values" window in the "Diagnostics" menu to open the "User Warnings" window (→ Figure 42).
- ▶ Check the window for yellow lights.

Figure 42 Main system bar with button "User" and opened "User Warnings" window

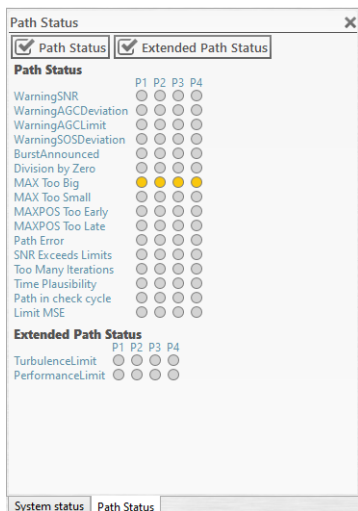

6.2.3 **Checking the diagnostic meter values**

The "Meter values" page displays detailed diagnostic information:

- ▶ Use FLOWgate™ to connect to the meter (→ pg. 61, 4.3).
- ▶ Choose the "Meter value" window from the "Diagnostics" menu to call up the "Meter values" page (→ Figure 35).
- ▶ Check the "Meter values" page for any yellow or red graphs or yellow or red indicators in the Main system bar. Yellow or red indicates a potential problem.

If any of the graphs or any of the icons in the main system bar are yellow or red, proceed with checking the "Meter Status" (→ pg. 95, 6.2.1) and the "User Warnings" (→ pg. 97, 6.2.2).

Problem	Possible causes	Actions
Implausible speed of sound	Gas composition, pressure or temperature measurement is incorrect	Check gas composition, pressure and temperature. Create a Diagnosis Session according to → pg. 99, 6.3. and contact your trained staff or your local Endress+Hauser representative.
Different speed of sound in the individual paths	Faulty transducer or electronic module	Create a Diagnosis Session according to → pg. 99, 6.3. and contact your trained staff or your local Endress+Hauser representative. Trained staff: Replace the transducer(s) (see Service Manual, Chapter 7). Note: Temperature-induced stratification can result in differences between the individual paths, especially with very low flow (higher temperatures generate higher speeds of sound). Even if the plant is being filled or if it is shut down, different speeds of sound may occur in the individual paths as a result of stratification.
Lower signal-to-noise ratio and reception sensitivity	Damaged transducer	Create a Diagnosis Session according to → pg. 99, 6.3. and contact your trained staff or your local Endress+Hauser representative. Trained staff: Replace the transducer(s) (see Service Manual, Chapter 7).
Increased number of rejected measurements in individual paths	Additional sources of noise due to a valve that is not fully open, fittings, noise sources near the device	Check the measurement plausibility and number of rejected measurements and, if necessary, eliminate noise sources. Create a Diagnosis Session according to → pg. 99, 6.3. and contact your trained staff or your local Endress+Hauser representative.
Increased receiver sensitivity (AGC)	Different gas composition or process pressure	No action required on the device
	Transducer(s) are dirty	Create a Diagnosis Session according to → pg. 99, 6.3. and contact your trained staff or your local Endress+Hauser representative. Trained staff: Clean the transducer(s) (see Service Manual, Chapter 7)
Increased number of rejected measurements in all paths	Additional noise sources	Eliminate noise sources
	Gas velocity outside the measuring range	

6.2.4 **Battery lifespan / capacity**

Because the FLOWSIC600 has no regular maintenance cycle, a user warning will be automatically generated if the remaining battery life is less than 15%. After 8.5 years, a warning is generated which forces the operator to change the battery. The battery may only be changed by trained staff. The procedure for changing the battery is described in the Service Manual.

Figure 43 Flashing message on the LCD display, prompts to change the battery

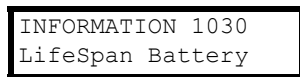
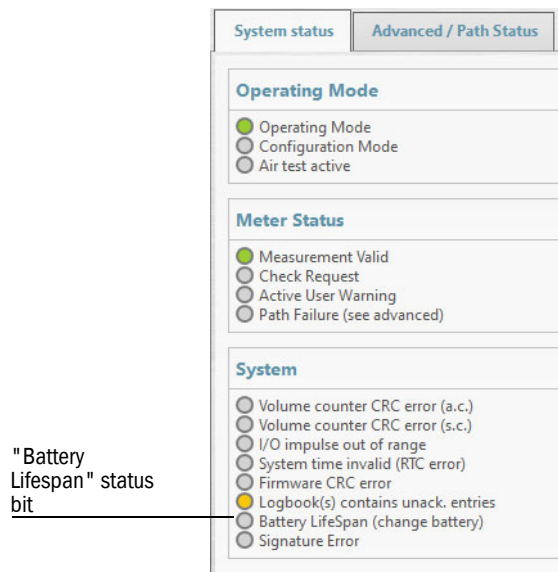

Figure 44 "Battery Lifespan" status bit in "Meter Status" window



6.3 **Creating a diagnostic session with FLOWgate™**

- ▶ Click "Start Diagnostic Session" (red cross icon) in the Status bar to start a diagnostic session.
- ▶ Select the desired data collection time.
It is recommended to select a minimum data collection time of 5 minutes and to load the logbooks archives (set checkmark at "Load logbooks").

Figure 45 Starting a diagnostic session .

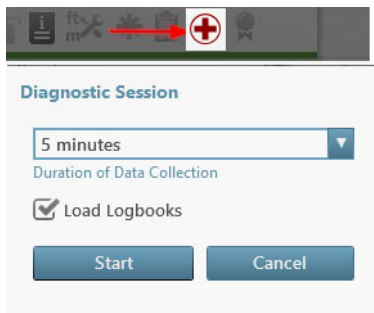

- ▶ Click “Start” to start recording.
The following message with the current storage location of the data collection is shown after successful creation of the diagnostic session.

Figure 46

Diagnostic session finished .

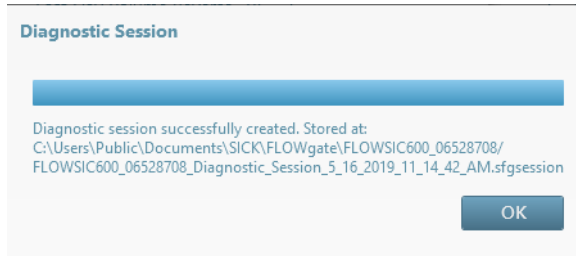

- ▶ Click “OK” to confirm the message.
 - Click “Save as” to select a storage location for the diagnostic recording.
 - Click “E-mail” to send the file per e-mail. The file is appended to an e-mail when an e-mail client is available.
 - Click “Close” to leave the file at the standard storage location.

Figure 47

Saving the diagnostic session .

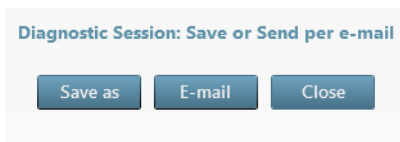

The diagnostic sessions are saved as files with the ending .sfgsession. The files are saved by default under:
C:\Users\Public\Documents\SICK\FLOWgate
The name of the storage folder consists of device type and serial number of the device

6.4 Meter connection troubleshooting

Meter not found at initial connection/connection lost during session

- ▶ Check all cables and the hardware. Check also the correct installation of the adapters (see → pg. 59, 4.2.1 and → pg. 60, 4.2.2).
- ▶ Attempt to re-establish connection via the "connect" button in the "DeviceManager" window.
- ▶ Use the scan option and "Configure for Scan" to make FLOWgate™ search with wider options, especially if parameters (e.g. the baud rate) may have been changed.

+i If necessary, the RS485 ports can be assigned to a specific bus address (Reg. #5020 "DeviceBusaddress"). The service port always has the bus address "1".

Figure 48 "Connection settings" dialog for the specification of wider search options.

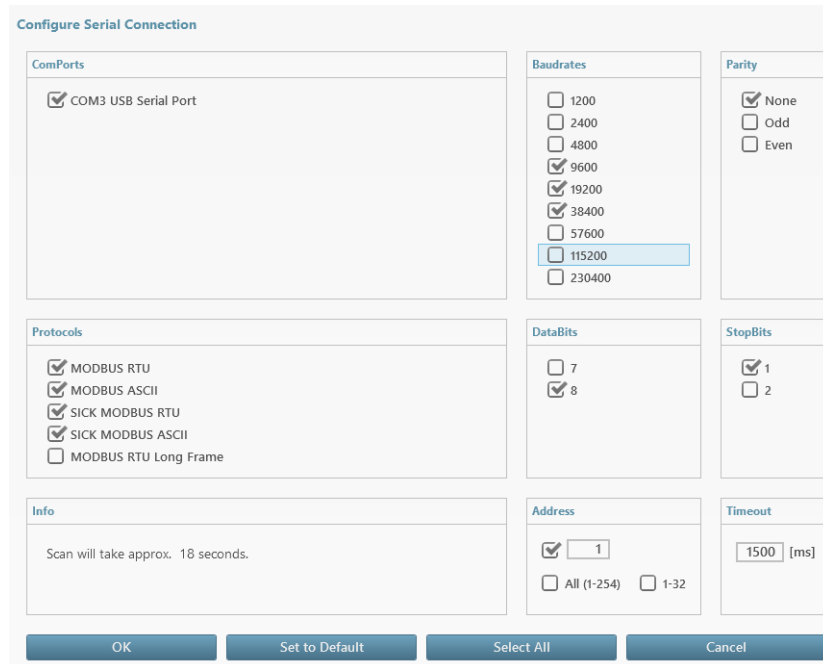

FLOWSIC600

7 Appendix

- Conformities and technical data
- Characteristic properties and dimensions of the meter body
- Operation and menu structure of the SPU with LCD display
 - Logbooks
 - SPU terminal assignment
- Connection diagrams for operating the FLOWSIC600 in hazardous areas in accordance with North American Guidelines (NEC, CEC)
 - Wiring examples
 - Sealing plan
 - Outline drawings

7.1 Conformities and technical data

7.1.1 CE certificate

The FLOWSIC600 has been developed, manufactured and tested in accordance with the following EU directives:

- Pressure Equipment Directive 2014/68/EU
- ATEX Directive 2014/34/EU
- EMC Directive 2014/30/EU

Conformity with above directives has been verified and the device has been marked with the CE label. The specific designation of the pressure equipment demanded according to the Pressure Equipment Directive 2014/68/EU under part 3.3 and 3.4 can be found in the MDR of the FLOWSIC600.

7.1.2 Standard compatibility and type approval

The FLOWSIC600 conforms to the following norms, standards or recommendations:

- EN IEC 60079-0:2018, EN 60079-1:2014, EN IEC 60079-7:2015, EN 60079-11:2012, EN 60079-26:2014
- OIML D 11, 2004, "General requirements for electronic measuring instruments"
- API 21.1 "Flow Measurement Using Electronic Metering Systems"
- ISO 17089-2:2012 "Measurement of fluid flow in closed conduits - Ultrasonic meters for gas Part 2: Meters for industrial applications"
- BS 7965, 2009, "Guide to the selection, installation, operation and calibration of diagonal path transit time ultrasonic flow meters for industrial gas applications."

7.1.3 WELMEC compliance

The interfaces and the software of the FLOWSIC600 have been designed non-reactive in terms of the Eichordnung, Anlage 7 "Messgeräte für Gas" (calibration regulations, Annex 7 "Gas Meters") and the requirements of the WELMEC regulation 7.2, and documented completely in document "Interface description".

The test results were archived in a traceable manner and can be provided on request.

Figure 49 Common key code (for short description of meter design, indicated on Type Plate* and Instrument Data Sheet**)

Type Code FLOW SIC600

Group	1	2	3	4	5	6	7	8	9	10	11	12	13	14	15
Key code FL600-															
METER BODY															
Path configuration															
1-Path	1	P													
2-Path	2	P													
4-Path	4	P													
1+1-Path redundant	1	R													
2+2-Path redundant	2	R													
4+4-Path (Quatro)	4	R													
4+1-Path (2plex)	5	C													
2-Path crossed	2	X													
4-Path crossed	4	X													
2-Path Special	2	S													
Overall length															
2D			2	D											
3D			3	D											
4D			4	D											
5D			5	D											
6D			6	D											
Shortened Meter body			S	D											
Other size			X	D											
Nominal size															
2" / DN 50			0	2											
3" / DN 80			0	3											
4" / DN 100			0	4											
6" / DN 150			0	6											
8" / DN 200			0	8											
10" / DN 250			1	0											
12" / DN 300			1	2											
16" / DN 400			1	6											
Other size			#	#											
Connection flange type															
ASME B16.5 / ASME B16.47 (>24")			C	L	#	#	#	#							
DIN EN 1092-1			P	N	#	#	#	#							
GOST 12815-80 / 12821-80 / GOST-R 54432-2011			P	N	#	#	#	#							
NORSOK L 005			N	K	#	#	#	#							
TECHLOK			I	N	X	X	#	#							
Grayloc			G	R	X	X	#	#							
EN 1759-1			C	L	#	#	#	#							
Other type			X	X	X	X	X	X							
Connection diameter															
Schedule ###					S	C	#	#	#	#	#				
Specified in [mm] (DIN)					#	#	#	#	#	.	#				
Flange type / sealing face															
Raised Face (ASME B16.5 / B16.47)										R	F				
Ring Type Joint (ASME B16.5 / B16.47)										R	J				
Form B1 (EN 1092-1 / 1759-1)										B	1				
Form B2 (EN 1092-1 / 1759-1)										B	2				
Form # Inlet / Form # Outlet (EN 1092-1 / 1759-1)										#	#				
Version V# (GOST 12815-80 / 12821-80)										V	#				
Type T# (GOST-R 54432-2011)										T	#				
Special design										X	X				
Material															
Carbon Steel										0					
Stainless steel										1					
LT-CS										2					
Duplex										3					
Superduplex										4					
Superaustenit										5					
Aluminium										6					
Other material										X					
Connection for Extraction Tool															
Yes															Y
No															N
ULTRASONIC TRANSDUCER (Will be selected by SICK on the basis of the technical data)															
SIGNAL PROCESSING UNIT															
Ex-proof-design															
None															0
CSA Group D T4															1
CSA Group B, C, D T4															2
ATEX IIA T4, M20x1.5															3
ATEX IIC T4, M20x1.5															4
ATEX IIA T4, 1/2 NPT															5
ATEX IIC T4, 1/2 NPT															6
IECEX IIA T4, M20x1.5															7
IECEX IIC T4, M20x1.5															8
IECEX IIA T4, 1/2 NPT															9
IECEX IIC T4, 1/2 NPT															A
Power supply															
12...24V DC															D
Data outputs															
Hardware variant 1 (4 digital outputs)															1
Hardware variant 2 (1 analog current output and 3 digital outputs)															2
Hardware variant 4 (1 analog current output and 2 RS485)															4
Hardware variant 5 (with integrated EVC, p- and T-transmitters externally power supplied, I/O board with DSP)															5
Hardware variant 6 (with integrated EVC, p- and T-transmitters internally power supplied, I/O board with DSP)															6
Hardware variant 7 (same as hardware variant 1, but with LowPressureAnalogBoard)															7
Hardware variant 8 (same as hardware variant 2, but with LowPressureAnalogBoard)															8
Hardware variant 9 (same as hardware variant 4, but with LowPressureAnalogBoard)															9
Hardware variant A (same as hardware variant 5, but with LowPressureAnalogBoard)															A
Hardware variant B (same as hardware variant 6, but with LowPressureAnalogBoard)															B
HART-Protocol (By selection of hardware variant 2 and 8 only)															
Yes															Y
No															N
Front panel															
LED SICK															0
LCD SICK															1
Custody transfer design meter															
Yes															Y
No															N

Rev. 1.12

2013/05

... to be specified by SICK

* ... only design of USM, no restriction to type approval (4P; 5C; 4R -> Y / other path configurations -> N)

E_69423

* See -> pg. 157, Figure 71

** The Instrument Data Sheet is included in the Manufacturer Data Report (MDR).

7.1.4 Common meter sizes and flow rates

Table 6 Common meter sizes and flow rates

	Nominal Size	Actual flow rate [m ³ /h]			Actual flow rate [ft ³ /h]		Max. Velocity*	
		Q _{min}	Q _t	Q _{max} ¹	Q _{min}	Q _{max} ¹	[m/sec]	[ft/sec]
TYPE APPROVAL	DN 50 (NPS 2)	4	13	400	140	14,000	65	213
	DN 80 (NPS 3)	8	32	1000	280	35,000	65	213
	DN 100 (NPS 4)	13	50	1,600	460	56,000	60	197
	DN 150 (NPS 6)	20	80	3000	710	106,000	50	164
	DN 200 (NPS 8)	32	130	4500	1,130	159,000	45	148
	DN 250 (NPS 10)	50	240	7000	1,770	247,000	40	131
	DN 300 (NPS 12)	65	375	8000	2,300	282,000	33	108
	DN 350 (NPS 14)	80	375	10000	2,830	353,000	33	108
	DN 400 (NPS 16)	120	600	14000	4,240	494,000	33	108
	DN 450 (NPS 18)	130	650	17000	4,600	600,000	33	108
	DN 500 (NPS 20)	200	975	20000	7,070	707,000	33	108
	DN 600 (NPS 24)	320	1500	32000	11,300	1,131,000	33	108
	DN 700 (NPS 28)	400	2000	40000	14,100	1,414,000	30	98
	DN 750 (NPS 30)	400	2000	45000	14,100	1,590,000	30	98
	DN 800 (NPS 32)	400	2400	50000	14,100	1,767,000	30	98
	DN 900 (NPS 36)	650	3750	66000	23,000	2,333,000	30	98
	DN 1000 (NPS 40)	650	5000	80000	23,000	2,828,000	30	98
	DN 1050 (NPS 42)	1300	6000	85,000	46,000	3,004,000	30	98
DN 1100 (NPS 44)	1400	6500	90000	49,500	3,181,000	28	92	
DN 1200 (NPS 48)	1600	7000	100000	56,600	3,535,000	27	89	

¹ Q_{max} can be limited by the working pressure and attenuation of the gas medium



*When a configuration with flow conditioner is used, the velocity of gas must not exceed 40 m/s (131 ft/s) in the pipe.

7.1.5

Technical data



NOTICE:

General technical parameters for FLOWSIC600 are listed in Table 7 “Technical data – General technical parameters for FLOWSIC600”.
For dedicated mediums (e.g. H₂, N₂, O₂, etc) see → S. 109, § 7.1.6 “Application specific technical data”.

Table 7 Technical data – General technical parameters for FLOWSIC600

Meter characteristics and measuring parameters		
Measured values	Flow rate, volume at flowing and base conditions, gas velocity, speed of sound	
Number of measuring paths	2, 4	
Measuring principle	Ultrasonic transit time difference measurement	
Measurement medium	Natural gas, air, C ₂ H ₄ , steam, process gases (e. g. CO ₂ up to 100%, N ₂ , O ₂ , Cl ₂ etc.), gases like sour gas or bio gas with high H ₂ S content	
Nominal pipe size	2" ... 48" (DN 50 ... DN 1200)	
Measuring ranges	Actual flow rate	4 ... 400 m ³ /h / 1,600 ... 100,000 m ³ /h (140 ... 14,000 ft ³ /h / 56,000 ... 3,535,000 ft ³ /h)
	Measuring ranges depending on nominal pipe size	
Repeatability	< 0.1 % of reading	
Accuracy	Typical error limits Q _t ... Q _{max} (Q _{min} ... Q _t)	
	2-path version ¹	≤ ± 1% (±2.0%)
	4-path version ¹	≤ ± 0.5% (±1.0%) Dry calibrated
Min. piping requirements	See → S. 33, § 3.2.2 “Installation configurations”	
Diagnostics functions	Integrated device diagnosis and extended diagnosis use software FLOWgate™	
Gas temperature	ATEX: -40 °C ... +105 °C (-40 °F ... +221 °F) at T1, T2, T3 -40 °C ... +91 °C (-40 °F ... +196 °F) at T4 Other Ex certifications: -40 °C ... +180 °C (-40 °F ... +356 °F) On request: -40 °C ... + 180 °C (-40 °F ... +356 °F)	
Operating pressure	0 bar (g) ... 250 bar (g) (0 psi (g) ... 3,626 psi (g)) On request: Up to 450 bar (g) (6,527 psi (g))	
Ambient conditions		
Ambient temperature	ATEX, CSA	-40 °C ... +60 °C (-40 °F ... +140 °F)
	IECEX	-40 °C ... +70 °C (-40 °F ... +158 °F)
	Optional IECEX	-50 °C ... +70 °C (-58 °F ... +158 °F)
Storage temperature	-40 °C ... +70 °C (-40 °F ... +158 °F)	
Ambient humidity	≤ 95% relative humidity	

Approvals	
Conformities	ISO 17089-2
Ex approvals	IECEX Ex d e ib [ia Ga] IIA T4 Ga/Gb Ex d e ib [ia Ga] IIC T4 Ga/Gb Ultrasonic transducer, intrinsically safe
	ATEX ⊕ II 1/2 (1) G Ex ia/db eb ia [ia Ga] IIA/IIB/IIC T4 ...T1 Ga/Gb ⊕ II 1/2 (1) G Ex ia/db eb ia [ia Ga] IIC T6 Ga/Gb Ultrasonic transducer, intrinsically safe
	NEC/CEC (US/CA) Class I, Div. 1, Groups B and C and D T4 Provide Intrinsically Safe Output for Class I, Div. 1, Groups B and C and D Class I, Div. 2, Groups A, B, C, and D, T4 Provide Intrinsically Safe Output for Class I, Div. 2, Groups A, B, C, and D Class I, Div. 1, Group D T4 Provide Intrinsically Safe Output for Class I, Div. 1, Group D Class I, Div. 2, Group D, T4 Provide Intrinsically Safe Output for Class I, Div. 2, Group D USA only: Class I, Zone 1, Group IIB + Hydrogen, T4 Provide Intrinsically Safe Output for Class I, Zone 1, Group IIB + Hydrogen, T4 Class I, Zone 2, Groups IIC, IIB, IIA T4 Provide Intrinsically Safe Output for Class I, Div. 2, Groups IIC, IIB, IIA
Electrical safety	CE
IP classification	IP 65 / IP 66 / IP 67
Outputs and interfaces	
Analog output	1 output (optional): 4 ... 20 mA, 200 Ω Active/passive, electrically isolated
Digital outputs	Up to 3 outputs: 30 V, 10 mA Passive, electrically isolated, open collector or acc. to NAMUR (EN 50227), f _{max} = 6 kHz (scalable)
Interfaces	RS-485 (2x, for configuration, measured value output and diagnosis)
Bus protocol	MODBUS ASCII MODBUS RTU HART
Operation	Via meter display and software FLOWgate™
Installation	
Dimensions (W x H x D)	See dimension drawings
Weight	Depending on device version
Material in contact with media	Low-temperature carbon steel, stainless steel, Duplex steel
Electrical connection	
Voltage	12 ... 28.8 V DC For active current output: 15 ... 28.8 V DC
Power input	≤ 1 W
General	
Scope of delivery	The scope of delivery is dependent on the application and the customer specifications.

¹ Typical accuracy may vary for process gases. See → S. 109, § 7.1.6 “Application specific technical data” for detailed information.

7.1.6 **Application specific technical data**

7.1.6.1 **Technical data for hydrogen (H₂) applications**

Table 8 Specific technical data for hydrogen applications

Meter characteristics and measuring parameters	
Measured values	Volumetric flow, a. c., volume a. c., gas velocity, speed of sound
Number of measuring paths	1+1 paths crossed (DN500 and DN600 2 paths in plane)
Measurement medium	H ₂ (95 ... 100%)
Accuracy	0.1 Q _{max} ... Q _{max} : ≤ ± 2.0% (un-calibrated), ≤ ± 4.0% below 0.1 Q _{max} (typical)
Operating pressure (typical)	5 ... 100 bar(a) (72.52 ... 1450.38 psi(a)) (minimum pressure depending on line size and H2 content)
Material	Meter Body: LT-CS (A352 LCC, A350 LF2), two layer RAL9003 coated or Stainless Steel (A182 Gr. 316/316L), uncoated Electronics: Aluminum or Stainless Steel Transducer: Stainless Steel
Flange type	ASME B16.5

Table 9 Specific technical data for hydrogen applications depending on nominal pipe size

	Flow rate [m ³ /h (ft ³ /h)]		Maximum Velocity [m/s (ft/s)]	Length (flange-to-flange) [mm (in)]	Weight (ANSI CL600) [kg (lbs)]
	min ¹	max			
DN150/6 inch	85 (3,000)	1710 (60,460)	30 (98.4)	450 (17.7)	150 (330.7)
DN200/8 inch	115 (4,062)	3000 (105,945)	30 (98.4)	600 (23.6)	220 (485)
DN250/10 inch	140 (4,939)	4600 (162,571)	30 (98.4)	750 (29.5)	330 (727.5)
DN300/12 inch	160 (5,654)	6200 (219,253)	30 (98.4)	900 (35.4)	500 (1,102.3)
DN400/16 inch	215 (7,594)	11000 (388,500)	30 (98.4)	762 (30)	650 (1,433)
DN500/20 inch	625 (22,071)	17200 (607,850)	30 (98.4)	902 (35.5)	990 (2,183)
DN600/24 inch	750 (26,460)	24700 (872,116)	30 (98.4)	991 (39.1)	1615 (3,560.5)

¹ Referenced speed of sound at 1350 m/s, equivalent e.g. p = 50 bar at T = 20 °C (100% H₂)

7.1.6.2 **Technical data for carbon dioxide (CO₂) applications**

Table 10 Specific technical data for carbon dioxide applications

Meter characteristics and measuring parameters	
Measured values	Volumetric flow, a. c., volume a. c., gas velocity, sound velocity
Number of measuring paths	2 (line size 3-6 inch / DN80-150), 4 (line size \geq 8 inch / DN200)
Measurement medium	CO ₂ (95 ... 100%), gaseous or super critical phase (single phase condition, not mixed)
Accuracy	0.1 Q _{max} ... Q _{max} :
	4-path meter (8 ... 24 inch) $\leq \pm 0.5\%$ (un-calibrated), $\leq \pm 1.0\%$ below 0.1 Q _{max} (typical)
	2-path meter (3 ... 6 inch) $\leq \pm 1.0\%$ (un-calibrated), $\leq \pm 2.0\%$ below 0.1 Q _{max} (typical)
Operating pressure (typical)	0 ... 100 bar (0 ... 1450.38 psi); (100 ... 250 bar (1450.38 ... 3625.95 psi) on request)
Material	Meter Body: LT-CS (A352 LCC, A350 LF2), two layer RAL9003 coated or Stainless Steel (A182 Gr. 316/316L), uncoated Electronics: Aluminum or Stainless Steel Transducer: Titanium
Flange type	ASME B16.5

Table 11 Specific technical data for carbon dioxide applications depending on nominal pipe size

	Flow rate [m ³ /h (ft ³ /h)]		Maximum Velocity [m/s (ft/s)]	Length (flange-to-flange) [mm (in)]	Weight (ANSI CL600) [kg(lbs)]
	min	max			
DN80/3 inch	8 (282.5)	390 (13,790)	24 (78.7)	320 (12.6)	42 (92.6)
DN100/4 inch	13 (459.8)	610 (21,523)	24 (78.7)	300 (11.8)	66 (145.5)
DN150/6 inch	20 (706.2)	1500 (52,910)	24 (78.7)	450 (17.7)	150 (330.7)
DN200/8 inch	32 (1,131)	2400 (84,851)	24 (78.7)	600 (23.6)	220 (485)
DN250/10 inch	50 (1,766)	3900 (137,778)	24 (78.7)	750 (29.5)	330 (727.5)
DN300/12 inch	65 (2,296)	4700 (165,725)	22 (72.1)	900 (35.4)	500 (1,102)
DN350/14 inch	80 (2,827)	6100 (215,423)	22 (72.1)	1050 (41.3)	580 (1,278)
DN400/16 inch	120 (4,243)	7900 (279,390)	22 (72.1)	762 (30)	650 (1,433)
DN500/20 inch	200 (7,062)	12200 (430,258)	21 (68.9)	902 (35.5)	990 (2,183)
DN600/24 inch	320 (11,325)	17000 (600,014)	21 (68.9)	991 (39.1)	1615 (3,560)

7.1.6.3 **Technical data for oxygen (O₂) applications**

Table 12 Specific technical data for oxygen applications

Meter characteristics and measuring parameters	
Measured values	Volumetric flow, a. c., volume a. c., gas velocity, sound velocity
Number of measuring paths	2 (line size 3-4 inch / DN80-150), 4 (line size ≥6 inch / DN200)
Measurement medium	O ₂
Accuracy	0.1 Q _{max} ... Q _{max} :
	4-path meter (8 ... 24 inch) ≤ ± 0.5% (un-calibrated), ≤ ± 1.0% below 0.1 Q _{max} (typical)
	2-path meter (3 ... 6 inch) ≤ ± 1.0% (un-calibrated), ≤ ± 2.0% below 0.1 Q _{max} (typical)
Operating pressure (typical)	0 ... 40 bar(g) (0 ... 580.15 psi(g)); (>40 bar (>580.15 psi) on request with limitation of v _{max} = 8 m/s (26.25 ft/s))
Material	Meter Body: LT-CS (A352 LCC, A350 LF2), two layer RAL9003 coated or Stainless Steel (A182 Gr. 316/316L), uncoated; Electronics: Aluminum or Stainless Steel Transducer: Stainless Steel
Flange type	ASME B16.5

Table 13 Specific technical data for oxygen applications depending on nominal pipe size

	Flow rate [m ³ /h (ft ³ /h)]		Maximum Velocity [m/s (ft/s)]	Length (flange-to-flange) [mm (in)]	Weight (ANSI CL600) [kg(lbs)]
	min	max ¹			
DN80/3 inch	8 (282.5)	400 (14,125)	25 (82)	240 (9.4)	42 (92.6)
DN100/4 inch	13 (459.8)	600 (21,188)	25 (82)	300 (11.8)	66 (145.5)
DN150/6 inch	20 (706.2)	1400 (49,440)	25 (82)	450 (17.7)	150 (330.7)
DN200/8 inch	32 (1,131)	2500 (88,286)	25 (82)	600 (23.6)	220 (485)
DN250/10 inch	50 (1,766)	4000 (141,258)	25 (82)	750 (29.5)	330 (727.5)
DN300/12 inch	65 (2,296)	5000 (176,573)	25 (82)	900 (35.4)	500 (1,102)
DN350/14 inch	80 (2,827)	7000 (247,202)	25 (82)	1050 (41.3)	580 (1,278)
DN400/16 inch	120 (4,243)	9000 (317,832)	25 (82)	762 (30)	650 (1,433)
DN500/20 inch	200 (7,062)	14000 (494,405)	25 (82)	902 (35.5)	990 (2,183)
DN600/24 inch	320 (11,325)	20000 (706,293)	25 (82)	991 (39.1)	1615 (3,560)

¹ max. velocity reduced to 8 m/s at pressure >40 bar(g)

7.1.6.4 **Technical data for nitrogen (N₂) applications**

Table 14 Specific technical data for nitrogen applications

Meter characteristics and measuring parameters	
Measured values	Volumetric flow, a. c., volume a. c., gas velocity, sound velocity
Number of measuring paths	4
Measurement medium	N ₂
Accuracy	0.1 Q _{max} ... Q _{max} : ≤ ± 0.5% (un-calibrated), ≤ ± 1.0% below 0.1 Q _{max} (typical)
Operating pressure (typical)	0 ... 100 bar (0 psi ... 1450.38 psi); (>100 bar (>1450.38 psi) on request)
Material	Meter Body: LT-CS (A352 LCC, A350 LF2), two layer RAL9003 coated Electronics: Aluminum Transducer: Titanium
Flange type	ASME B16.5

Table 15 Specific technical data for nitrogen applications depending on nominal pipe size

	Flow rate [m ³ /h (ft ³ /h)]		Maximum Velocity [m/s (ft/s)]	Length (flange-to-flange) [mm (in)]	Weight (ANSI CL600) [kg (lbs)]
	min	max			
DN80/3 inch	8 (282.5)	650 (22,971)	40 (131.2)	240 (9.4)	42 (92.6)
DN100/4 inch	13 (459.8)	1000 (35,314)	40 (131.2)	300 (11.8)	66 (145.5)
DN150/6 inch	20 (706.2)	2200 (77,692)	40 (131.2)	450 (17.7)	150 (330.7)
DN200/8 inch	32 (1,131)	4000 (141,258)	40 (131.2)	600 (23.6)	220 (485)
DN250/10 inch	50 (1,766)	6200 (219,253)	40 (131.2)	750 (29.5)	330 (727.5)
DN300/12 inch	65 (2,296)	7800 (276,453)	40 (131.2)	900 (35.4)	500 (1,102)
DN350/14 inch	80 (2,827)	10000 (353,147)	35 (114.8)	1050 (41.3)	580 (1,278)
DN400/16 inch	120 (4,243)	13000 (459,091)	35 (114.8)	762 (30)	650 (1,433)
DN500/20 inch	200 (7,062)	20000 (706,293)	35 (114.8)	902 (35.5)	990 (2,183)
DN600/24 inch	320 (11,325)	28000 (989,811)	34 (111.5)	991 (39.1)	1615 (3,560)

7.1.6.5 **Technical data for ammonia (NH₃) applications**

Table 16 Specific technical data for ammonia applications

Meter characteristics and measuring parameters	
Measured values	Volumetric flow, a. c., volume a. c., gas velocity, sound velocity
Number of measuring paths	4
Measurement medium	NH ₃
Accuracy	0.1 Q _{max} ... Q _{max} : ≤ ± 0.5% (un-calibrated), ≤ ± 1.0% below 0.1 Q _{max} (typical)
Operating pressure (typical)	0 bar ... 100 bar (0 psi ... 1450.38 psi) (in gaseous and supercritical phase)
Material	Meter Body: LT-CS (A352 LCC, A350 LF2), two layer RAL9003 coated or Stainless Steel (A182 Gr. 316/316L), uncoated Electronics: aluminum Transducer: titanium, stainless steel
Flange type	ASME B16.5

Table 17 Specific technical data for ammonia applications depending on nominal pipe size

	Flow rate [m ³ /h (ft ³ /h)]		Maximum Velocity [m/s (ft/s)]	Length (flange-to-flange) [mm (in)]	Weight (ANSI CL600) [kg(lbs)]
	min	max			
DN80/3 inch	8 (282.5)	650 (22,971)	40 (131.2)	240 (9.4)	42 (92.6)
DN100/4 inch	13 (459.8)	1000 (35,314)	40 (131.2)	300 (11.8)	66 (145.5)
DN150/6 inch	20 (706.2)	2200 (77,692)	40 (131.2)	450 (17.7)	150 (330.7)
DN200/8 inch	32 (1,131)	4000 (141,258)	40 (131.2)	600 (23.6)	220 (485)
DN250/10 inch	50 (1,766)	6200 (219,253)	40 (131.2)	750 (29.5)	330 (727.5)
DN300/12 inch	65 (2,296)	7800 (276,453)	40 (131.2)	900 (35.4)	500 (1,102)
DN350/14 inch	80 (2,827)	10000 (353,147)	35 (114.8)	1050 (41.3)	580 (1,278)
DN400/16 inch	120 (4,243)	13000 (459,091)	35 (114.8)	762 (30)	650 (1,433)
DN500/20 inch	200 (7,062)	20000 (706,293)	35 (114.8)	902 (35.5)	990 (2,183)
DN600/24 inch	320 (11,325)	28000 (989,811)	34 (111.5)	991 (39.1)	1615 (3,560)

7.1.6.6 **Technical data for ethylene (C₂H₄) applications**

Table 18 Specific technical data for ethylene applications

Meter characteristics and measuring parameters	
Measured values	Volumetric flow, a. c., volume a. c., gas velocity, sound velocity
Number of measuring paths	4
Measurement medium	C ₂ H ₄
Accuracy	0.1 Q _{max} ... Q _{max} : ≤ ± 0.5% (un-calibrated), ≤ ± 1.0% below 0.1 Q _{max} (typical)
Operating pressure (typical)	0 bar ... 100 bar (0 psi ... 1450.38 psi) (in gaseous and supercritical phase)
Material	Meter Body: LT-CS (A352 LCC, A350 LF2), two layer RAL9003 coated or Stainless Steel (A182 Gr. 316/316L), uncoated Electronics: aluminum Transducer: titanium, stainless steel
Flange type	ASME B16.5

Table 19 Specific technical data for ethylene applications depending on nominal pipe size

	Flow rate [m ³ /h (ft ³ /h)]		Maximum Velocity [m/s (ft/s)]	Length (flange-to-flange) [mm (in)]	Weight (ANSI CL600) [kg(lbs)]
	min	max ¹			
DN80/3 inch	8 (282.5)	650 (22,971)	40 (131.2)	240 (9.4)	42 (92.6)
DN100/4 inch	13 (459.8)	1000 (35,314)	40 (131.2)	300 (11.8)	66 (145.5)
DN150/6 inch	20 (706.2)	2200 (77,692)	40 (131.2)	450 (17.7)	150 (330.7)
DN200/8 inch	32 (1,131)	4000 (141,258)	40 (131.2)	600 (23.6)	220 (485)
DN250/10 inch	50 (1,766)	6200 (219,253)	40 (131.2)	750 (29.5)	330 (727.5)
DN300/12 inch	65 (2,296)	7800 (276,453)	40 (131.2)	900 (35.4)	500 (1,102)
DN350/14 inch	80 (2,827)	10000 (353,147)	35 (114.8)	1050 (41.3)	580 (1,278)
DN400/16 inch	120 (4,243)	13000 (459,091)	35 (114.8)	762 (30)	650 (1,433)
DN500/20 inch	200 (7,062)	20000 (706,293)	35 (114.8)	902 (35.5)	990 (2,183)
DN600/24 inch	320 (11,325)	28000 (989,811)	34 (111.5)	991 (39.1)	1615 (3,560)

¹ Q_{max} could be lower at low speed of sound

7.1.6.7 **Technical data for argon (Ar) applications**

Table 20 Specific technical data for argon applications

Meter characteristics and measuring parameters	
Measured values	Volumetric flow, a. c., volume a. c., gas velocity, sound velocity
Number of measuring paths	4
Measurement medium	Ar
Accuracy	0.1 Q _{max} ... Q _{max} : ≤ ± 0.5% (un-calibrated), ≤ ± 1.0% below 0.1 Q _{max} (typical)
Operating pressure (typical)	0 bar ... 100 bar (0 psi ... 1450.38 psi) (in gaseous and supercritical phase)
Material	Meter Body: LT-CS (A352 LCC, A350 LF2), two layer RAL9003 coated or Stainless Steel (A182 Gr. 316/316L), uncoated Electronics: aluminum Transducer: titanium, stainless steel
Flange type	ASME B16.5

Table 21 Specific technical data for argon applications depending on nominal pipe size

	Flow rate [m ³ /h (ft ³ /h)]		Maximum Velocity [m/s (ft/s)]	Length (flange-to-flange) [mm (in)]	Weight (ANSI CL600) [kg(lbs)]
	min	max			
DN80/3 inch	8 (282.5)	650 (22,971)	40 (131.2)	240 (9.4)	42 (92.6)
DN100/4 inch	13 (459.8)	1000 (35,314)	40 (131.2)	300 (11.8)	66 (145.5)
DN150/6 inch	20 (706.2)	2200 (77,692)	40 (131.2)	450 (17.7)	150 (330.7)
DN200/8 inch	32 (1,131)	4000 (141,258)	40 (131.2)	600 (23.6)	220 (485)
DN250/10 inch	50 (1,766)	6200 (219,253)	40 (131.2)	750 (29.5)	330 (727.5)
DN300/12 inch	65 (2,296)	7800 (276,453)	40 (131.2)	900 (35.4)	500 (1,102)
DN350/14 inch	80 (2,827)	10000 (353,147)	35 (114.8)	1050 (41.3)	580 (1,278)
DN400/16 inch	120 (4,243)	13000 (459,091)	35 (114.8)	762 (30)	650 (1,433)
DN500/20 inch	200 (7,062)	20000 (706,293)	35 (114.8)	902 (35.5)	990 (2,183)
DN600/24 inch	320 (11,325)	28000 (989,811)	34 (111.5)	991 (39.1)	1615 (3,560)

7.1.6.8 **Technical data for steam applications**

Table 22 Technical data for steam applications

Meter characteristics												
Nominal size	Flow rate				Max. Velocity		Length		Weight		Order code ¹	
	[m ³ /h]		[ft ³ /h]		[m ³ /h]	[ft/s]	[mm]	[in]	[kg]	[lbs]		
	Min.	Max.	Min.	Max.								
DN 50/2 inch	4	400	140	14,000	55	180	250	9.8	40	88	FL6ST-02CL600-*	
DN80/3 inch	8	1,000	280	35,000	61	200	320	12.5	60	132	FL6ST-03CL600-*	
DN100/4 inch	13	1,600	460	56,000	55	180	300	11.8	80	176	FL6ST-04CL600-*	
DN150/6 inch	20	3,000	710	106,000	46	151	450	17.6	140	309	FL6ST-06CL600-*	
DN200/8 inch	32	4,500	1,130	159,000	39	128	600	23.5	200	441	FL6ST-08CL600-*	
DN250/10 inch	50	7,000	1,770	247,000	38	125	750	29.4	320	705	FL6ST-10CL600-*	
DN300/12 inch	65	8,000	2,300	282,000	30	98	900	35.3	490	1,080	FL6ST-12CL600-*	
DN350/14 inch	80	10,000	2,830	353,000	30	98	1,050	41.2	570	1,257	FL6ST-14CL600-*	
DN400/16 inch	120	14,000	4,240	494,000	30	98	762	29.9	630	1,389	FL6ST-16CL600-*	
Materials	Meter body: Low temperature carbon steel Transducers: Titanium Electronics: Aluminum											
Flange type	ASME B16.5, Raised face ²											
Meter body finish	Meter body: nickel plated, covers: RAL7012											
Measuring parameters												
Fluid	Steam up to 280 °C (536 °F)											
Process value	Volumetric flow, volume totals at actual conditions velocity of gas, speed of sound											
Measurement principle	Ultrasonic transit time difference measurement											
Typical accuracy ^{3, 4}							DN50 / 2"			DN80 / 3" or larger		
	10% Q _{max} ... Q _{max}						±1.5% of rate			±1% of rate ⁵		
Repeatability	< 0.1 %											
Process temperature	- 15 °C ... + 280 °C (+5 °F ... +536 °F)											
Pressure rating	CL600 ²											
Approvals												
Conformities	ISO 17089-2											
Ex approvals	CSA, ATEX, IECEx, zone 1 and zone 2 IIC T4 rating, transducers intrinsically safe											
Electrical Safety	CE											
IP classification	IP 67											
Ambient conditions												
Temperature	-40 °C ... + 60 °C (-40 °F ... +140 °F)											
Humidity	≤ 95%											
Power supply, Outputs and Interfaces												
Voltage	15 ... 28.8 V DC, ≤ 1 W											
Analog output	4 ... 20 mA (@ 200 Ω), Active/passive mode, isolated											
Digital outputs	1x pulse, 2x status, isolated, OC or NAMUR, frequency @ Q _{max} = 2 kHz											
Digital interfaces	RS485, Modbus ASCII/RTU, HART rev. 5											
Display	2-line LCD											

¹ Order of ATEX version - replace * with A, Order of CSA version - replace * with C, IIECEX version on request

² Other pressure ratings or flange types available on request

³ With good piping conditions (developed flow profile). Typical uncertainty below Q_t is ±3.0% for DN50 (2") and ±2.0% for DN80 (3") or larger

⁴ With a steam quality of ≥ 80%

⁵ Accuracy ±0.5% available on request

7.2 **Design pressure and design temperature**

Please refer to the supplied acceptance test certificate (EN 10204 - 3.1) and the type plate on the meter body for the actual values for the design pressure and design temperature for your specific device.

Figure 50 Example acceptance test certificate (EN10204 - 3.1)



Abnahmeprüfzeugnis / Inspection certificate
EN10204 – 3.1

Zeugnis Nr. / Certificate No.: 12345678

1 Allgemeine Angaben / General

Typ / Type	FL600-.....	
Serien-Nr. / Serial No:	12345678	
Baujahr / Year of manufacturing:	2025	
Max. Betriebsdruck / Max. Operating pressure	100 bar	
Arbeitstemperatur / Working temperature	Min.: -40°C	Max.: +70°C

Figure 51 Meter body type plate (example)

Endress+Hauser FLOWSIC600 Made in Germany Endress+Hauser SICK GmbH+Co. KG Bürger Ring 27, 73486 Olfersbach, Germany	Serial no.	12345678	
	TS	-40...+70 °C	
	PS	100 bar	
	PT	150 bar	
	DN / NPS	50 / 2"	
	Weight	22 kg	
	Category	III	
	Fluid grp.	1	
	Date		2025-07
	 0062		791163

- TS Minimum/Maximum design temperature
- PS Maximum design pressure
- PT Test pressure

7.3 **Characteristic properties and dimensions of the meter body****Standard materials for meter body**

Material			Pressure-Temperature-Rating		Min. application temp.
			Flanges acc. to ASME B16.5 and ASME B16.47	Flanges acc. to EN 1092-1	
LT carbon steel	Casting	1.6220 (ASTM A352 Gr. LCC)	Table 2-1.2 of ASME B16.5	Rating for Material Group 7EO	- 46 °C
	Forging	1.0571 (1.0566)/ASTM A350 Gr. LF2	Table 2-1.1 of ASME B16.5	Rating for Material Group 8E3	
Stainless steel	Casting	1.4408 (ASTM A351 Gr. CF8M)	Table 2-2.2 of ASME B16.5	Rating for Material Group 14EO	- 196 °C
	Forging	1.4401 (1.4404)/ASTM A182 Gr. F316 (F316L)	Table 2-2.2 of ASME B16.5	Rating for Material Group 14EO	
Duplex	Casting	1.4470 (ASTM A995 Gr.4A)	-	Rating for Material Group 16EO	- 46 °C
	Forging	1.4462/ASTM A182 Gr. F51	Table 2-2.8 of ASME B16.5	Rating for Material Group 16EO	

Weights and dimensions

Figure 52 Dimensioned drawing
Models for nominal sizes of 3"/DN 80 up to 14"/DN 350 (cast)

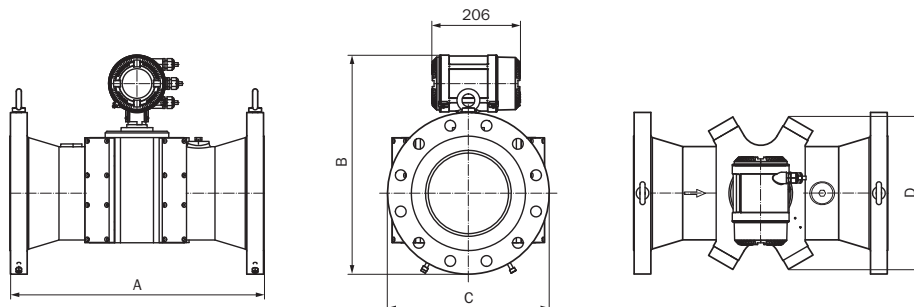

Models for nominal sizes from 16"/DN 400 (forged)

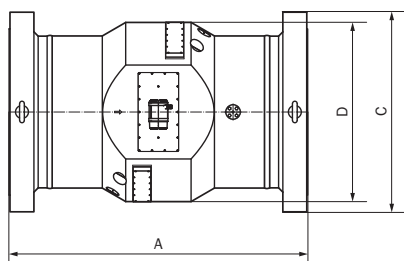

Longitudinal section for nominal sizes up to 48"/DN 1200

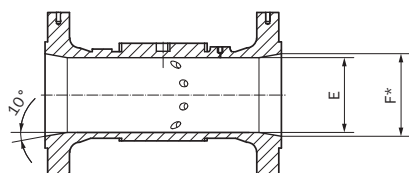

* Dimension F must be specified by the customer, as it depends on the internal pipe diameter at the installation location. (see → pg. 124, Table 24 or type-code)

Table 23 Meter dimensions

Nominal pipe size	Connection flange	Standard	Weight	Length (A)	Height (B)	Flange diameter (C)	Width of measuring section (D)	Internal diameter (E)
			[kg]	[mm]	[mm]	[mm]	[mm]	[mm]
3"	cl. 150	ANSI B16.5	37	240	344	190	180	73
	cl. 300		38		354	210		
	cl. 600		42	354	210			
	cl. 900		84	400	395	240		
DN80	PN 16	DIN 2633	37	240	349	200		
	PN 63	DIN 2636	40		356	215		
	PN 100	DIN 2637	43		364	230		
4"	cl. 150	ANSI B16.5	44	300	375	230	240	95
	cl. 300		55		388	255		
	cl. 600		66		398	275		
	cl. 900		99	500	408	290		
DN100	PN 16	DIN 2633	40	300	372	220		
	PN 63	DIN 2636	52		405	250		
	PN 100	DIN 2637	61		410	265		
6"	cl. 150	ANSI B16.5	100	450	445	280	300	142
	cl. 300		110		465	320		
	cl. 600		140		483	355		
	cl. 900		220	750	496	380		
DN150	PN 16	DIN 2633	90	450	448	285		
	PN 63	DIN 2636	110		478	345		
	PN 100	DIN 2637	130		483	355		
8"	cl. 150	ANSI B16.5	150	600	498	345	350	190
	cl. 300		180		516	380		
	cl. 600		210		536	420		
	cl. 900		300		562	470		
DN200	PN 16	DIN 2633	140		498	340		
	PN 63	DIN 2636	190		535	415		
	PN 100	DIN 2637	210		543	430		
10"	cl. 150	ANSI B16.5	240	750	548	405	410	235
	cl. 300		250		568	445		
	cl. 600		330		600	510		
	cl. 900		470		625	545		
DN250	PN 16	DIN 2633	220		547	405		
	PN 63	DIN 2636	270		580	470		
	PN 100	DIN 2637	320		597	505		
12"	cl. 150	ANSI B16.5	350	900	586	485	470	270
	cl. 300		400		605	520		
	cl. 600		490		625	560		
	cl. 900		720		685	610		
DN300	PN 16	DIN 2633	325		575	460		
	PN 63	DIN 2636	425		610	530		
	PN 100	DIN 2637	525		638	585		

Table 23 Meter dimensions

Nominal pipe size	Connection flange	Standard	Weight	Length (A)	Height (B)	Flange diameter (C)	Width of measuring section (D)	Internal diameter (E)	
			[kg]	[mm]	[mm]	[mm]	[mm]	[mm]	
14"	cl. 150	ANSI B16.5	475	1050	642	535	540	315	
	cl. 300		600		667	585			
	cl. 600		675		677	605			
	cl. 900		850		700	640			
DN80	PN 16	DIN 2633	475		635	520			
	PN 63	DIN 2636	625		675	600			
	PN 100	DIN 2637	750		705	655			
The length 3D is also available for all size 16" meters and larger.									
16"	cl. 150	ANSI B16.5	475	762	700	595	570	360	
	cl. 300		550		728	650			
	cl. 600		640		745	685			
	cl. 900		1025		800	755			705
DN400	PN 16	DIN 2633	370	762	693	580			
	PN 63	DIN 2636	600		738	670			
18"	cl. 150	ANSI B16.5	660	820	754	635	620	405	
	cl. 300		760		792	710			
	cl. 600		960		820	745			
	cl. 900		1300		900	830			785
DN450	PN 16	Data on request							
20"	cl. 150	ANSI B16.5	750	902	815	700	670	450	
	cl. 300		930		853	775			
	cl. 600		1080		872	815			
	cl. 900		1500		1000	892			855
DN500	PN 16	DIN 2633	700	902	823	715			
22"	cl. 150	Data on request							
	cl. 300								
	cl. 600								
	cl. 900								
DN550	PN 16								
24"	cl. 150	ANSI B16.5	1090	991	927	815	760	540	
	cl. 300		1390		991	978			915
	cl. 600		1615		991	990			940
	cl. 900		2450		1200	1040			1040
DN600	PN 16	DIN 2633	1015	991	940	840			
26"	cl. 150	ASME B16.47	1475	1050	965	870	828	585	
	cl. 300		1825		1016	972			
	cl. 600		2100		1038	1016			
	cl. 900		2500		1250	1073			1086
DN650	PN16	Data on request							
28"	cl. 150	ASME B16.47	1950	1100	1027	927	862	630	
	cl. 300		2225		1080	1035			
	cl. 600		2450		1100	1073			
	cl. 900		3000		1300	1150			1169
DN700	PN16	Data on request							

Table 23 Meter dimensions

Nominal pipe size	Connection flange	Standard	Weight	Length (A)	Height (B)	Flange diameter (C)	Width of measuring section (D)	Internal diameter (E)	
			[kg]	[mm]	[mm]	[mm]	[mm]	[mm]	
30"	cl. 150	ASME B16.47	2195	1150	1080	985	902	675	
	cl. 300		2545		1135	1092			
	cl. 600		2820		1154	1130			
	cl. 900		3350	1350	1205	1232			
DN750	PN16	Data on request							
32"	cl. 150	ASME B16.47	2485	1200	1145	1061	979	720	
	cl. 300		2835		1190	1150			
	cl. 600		3110		1212	1194			
	cl. 900		3800	1400	1272	1315			
DN800	PN 16	Data on request							
34"	cl. 150	Data on request							
	cl. 300								
	cl. 600								
	cl. 900								
DN850	PN 16	Data on request							
36"	cl. 150	ASME B16.47	3125	1250	1250	1169	1082	810	
	cl. 300		3525		1300	1270			
	cl. 600		3850		1323	1315			
	cl. 900		5225	1450	1396	1461			
DN900	PN 16	Data on request							
38"	cl. 150	ASME B16.47	3800	1300	1310	1238	1160	855	
	cl. 300		3725		1275	1169			
	cl. 600		4300		1325	1270			
	cl. 900		-	-	1421	1461			
DN950	PN 16	Data on request							
40"	cl. 150	ASME B16.47	3825	1350	1359	1289	1213	900	
	cl. 300		4125		1334	1239			
	cl. 600		4675		1375	1321			
	cl. 900		Data on request	1470	1512				
DN1000	PN 16	Data on request							
42"	cl. 150	ASME B16.47	4675	1450	1415	1346	1261	945	
	cl. 300		4650		1386	1289			
	cl. 600		5450		1444	1404			
	cl. 900		Data on request	1523	1562				
DN1050	PN 16	Data on request							
44"	cl. 150	Data on request							
	cl. 300								
	cl. 600								
	cl. 900								
DN1100	PN 16	Data on request							
46"	cl. 150	Data on request							
	cl. 300								
	cl. 600								
	cl. 900								
DIN1150	PN 16	Data on request							

Table 23 Meter dimensions

Nominal pipe size	Connec-tion flange	Standard	Weight	Length (A)	Height (B)	Flange diameter (C)	Width of measuring section (D)	Internal diameter (E)
			[kg]	[mm]	[mm]	[mm]	[mm]	[mm]
48"	cl. 150	ASME B16.47	6400	1600	1574	1511	1416	1080
	cl. 300		6475		1552	1467		
	cl. 600		7850		1615	1594		
	cl. 900		12100	1900	1711	1785		
DN1200	PN 16	Data on request						



- Weight indications are to be considered as guide values.
- Weight indications are estimated for carbon steel.

Table 24 Inner pipe diameter

Nominal pipe size	Pipe dimensions in accordance with ANSI B36.10M - 1985					DIN 2633	DIN 2636	DIN 2637
	SC20	SC30	SC40	SC60	SC80	PN16	PN64	PN100
2"			52.5		49.3			
DN 50						54.5	54.5	54.5
3"			77.9		73.7			
DN 80						82.5	81.5	80.9
4"			102.3		97.2			
DN 100						107.1	106.3	104.3
6"			154.1		146.3			
DN 150						159.3	157.1	154.1
8"	206.4	205	202.7	198.5	193.7			
DN 200						206.5	204.9	199.1
10"	260.4	257.5	254.5	247.7	242.9			
DN 250						260.4	255.4	248.0
12"	311.2	307.1	303.2	295.3	288.9			
DN 300						309.7	301.9	295.5
14"	339.8	336.6	333.3	325.4	317.5			
DN 350						339.6	343.0	336.0
16"	390.6	387.4	381.0	373.1	363.5			
DN 400						390.4	378	
18"	441.4	434.9	428.7	419.1	409.5			
DN 450								
20"	489.0	482.6	477.8	466.8	455.6			
DN 500						492.0		
24"	590.6	581.1	574.6	560.4	547.7			
DN 600						592.4		

7.4

Operation and menu structure of the SPU with LCD display

7.4.1

Operation

The current measured values, counter readings, and diagnostic information can be displayed on the two-line LCD display on the front panel of the SPU. The information display can be navigated by using a magnetic pen, while the front cap is kept closed, or using the buttons while the front cap is open (see → Figure 53).

**WARNING: Explosion Hazard**

Do not open the window cover unless the area is known to be non-hazardous.

**WARNING:**

EMC and protection from accidental contact cannot be guaranteed if the cover is opened.

Figure 53 Front panel with LCD display

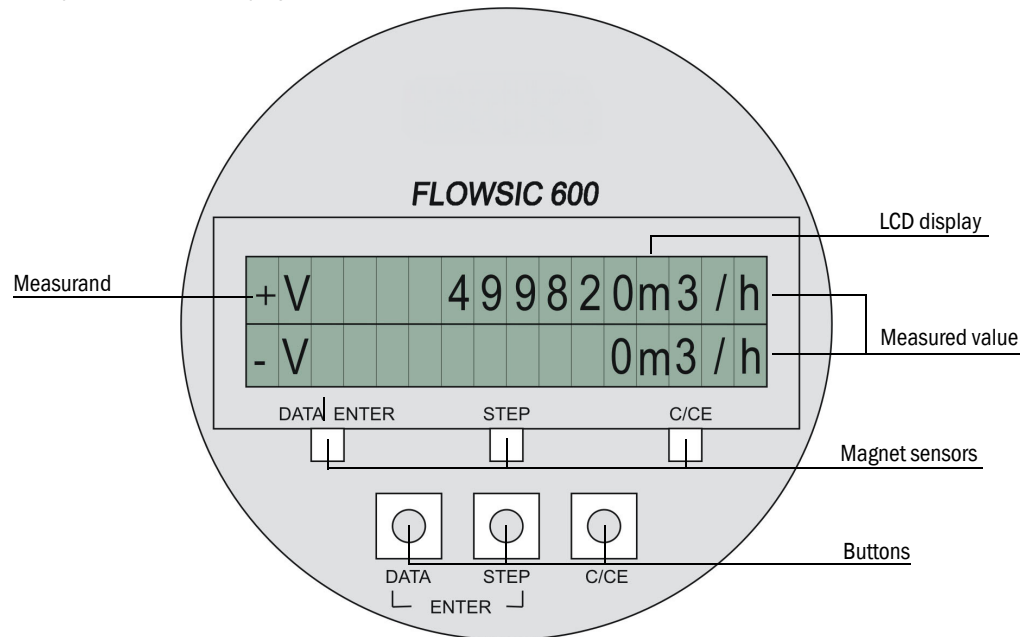

Button	Magnetic sensor	Function	Description
C/CE	C/CE	Menu level up	Use the C/CE button to return from any menu to the upper level; continue pressing to return to the initial display
STEP	STEP	Step forward	Use the STEP button to step forward in the menu
DATA	DATA ENTER	Step backward	Use the DATA button to step backward in the menu
STEP + DATA pressed together or DATA pressed longer than 2 seconds	DATA ENTER pressed longer than 2 seconds	ENTER	Use the ENTER function to select a menu level, acknowledge logbook entries, reset the error volume counters or edit any modifiable parameter (after unlocking the Parameter write lock)

7.4.2 **Menu structure on the LCD display**

The menu structure on the LCD display consists of a standard display (displaying readings, important errors or warnings, the device state and a submenu for the reset of the error volume counters) and the main menu. The main menu provides topically structured information and allows operations like changing parameters, acknowledging logged events. Navigate standard display and main menu using the buttons or the magnetic sensors as described below.

+i Parameters can be edited in "Configuration" mode only.

Graphical representation	Description
	Vertical lines represent connections between menu items on the same menu level. Use the STEP button to step forward and the DATA button to step backward
_____	Horizontal lines represent connections between different menu levels. Use the ENTER function to enter a lower-level menu and the C/CE button to go back to a higher-level menu.
- - - - -	Dashed horizontal or vertical lines represent connections between alternating displays pages
[Thick border box]	Boxes with a thick border represent the display of a menu item
[Grey border box]	Boxes with a grey border represent a flashing display (e.g. if a current warning or an unacknowledged logbook entry is displayed)

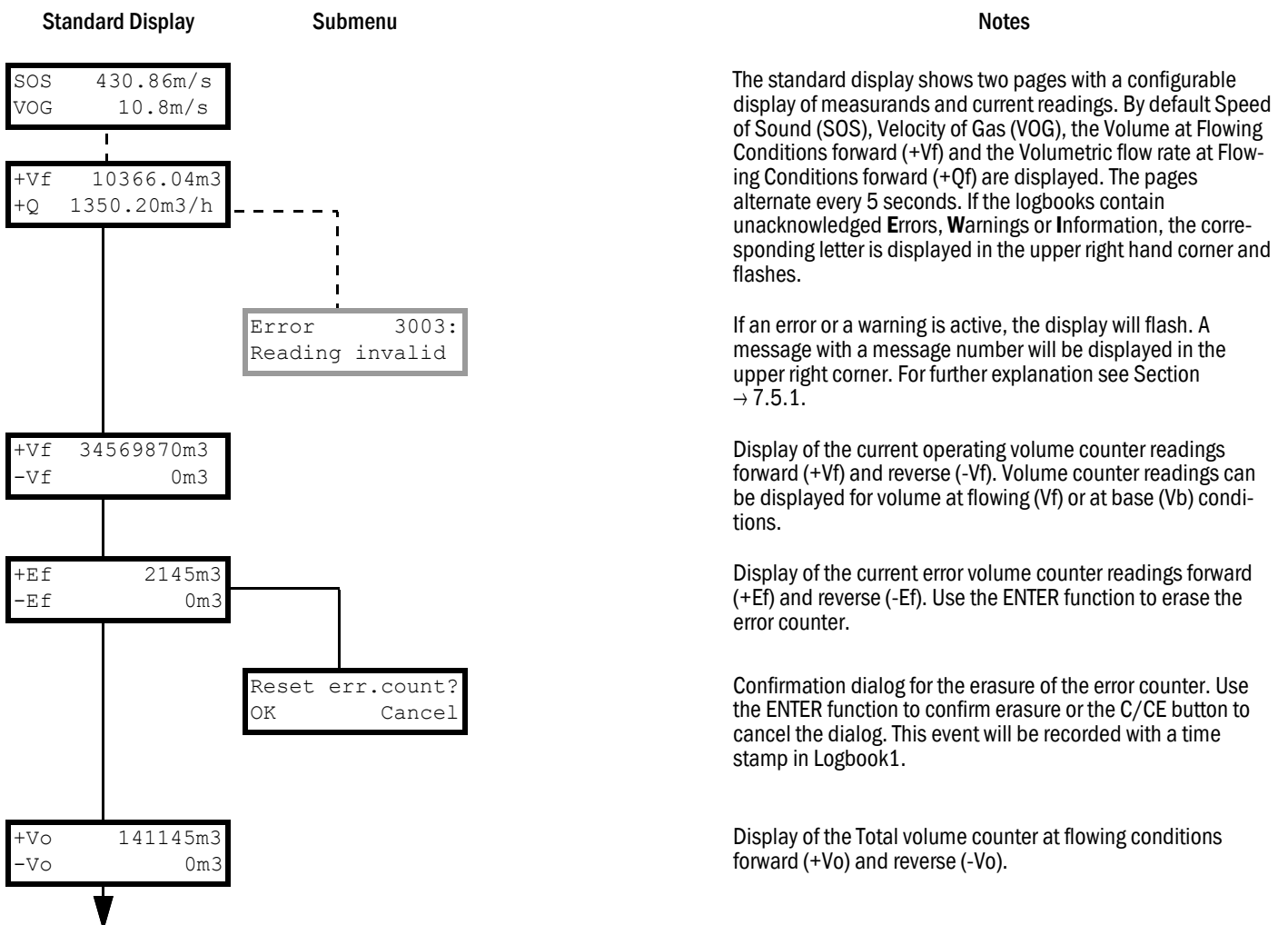

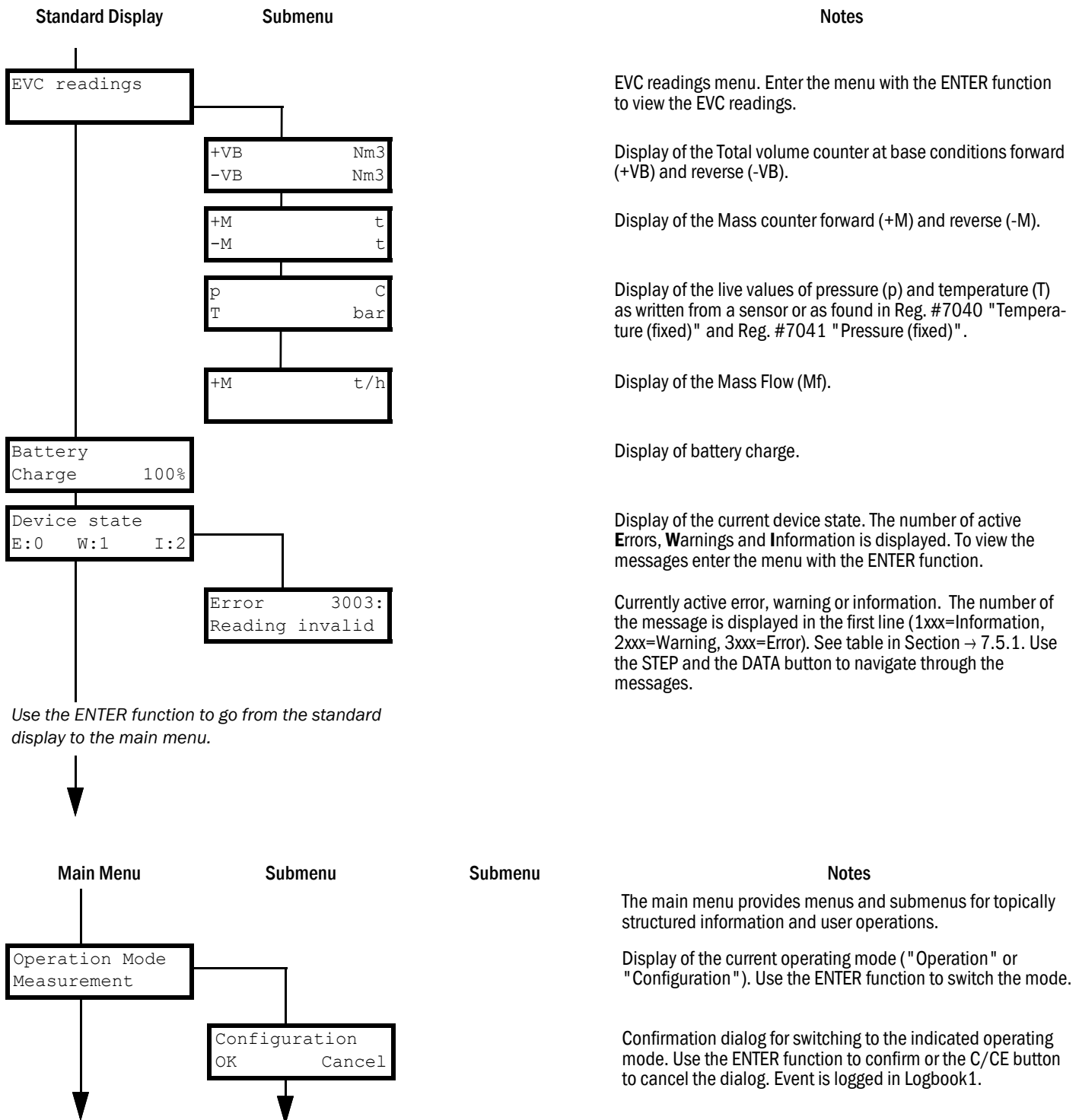

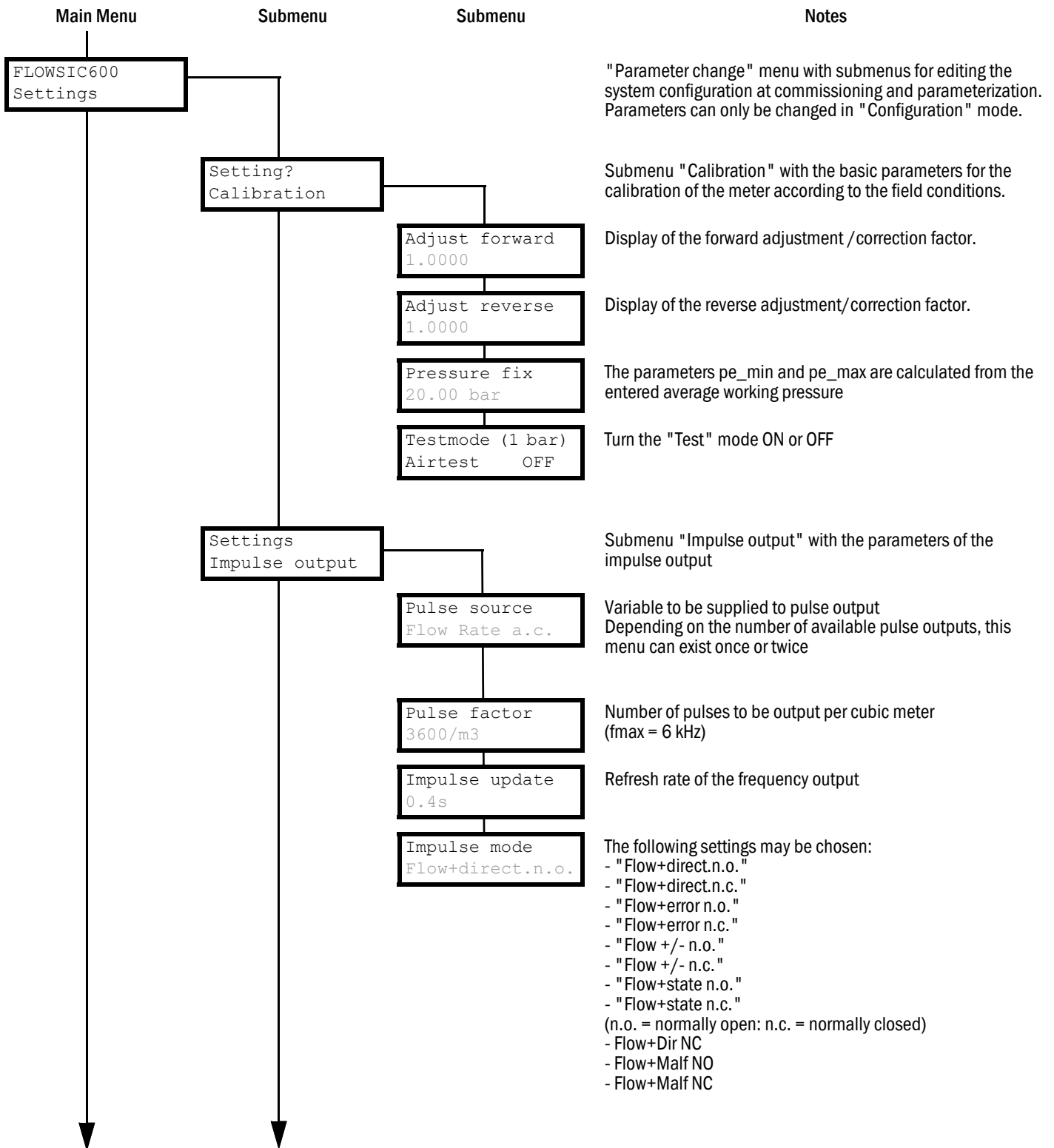

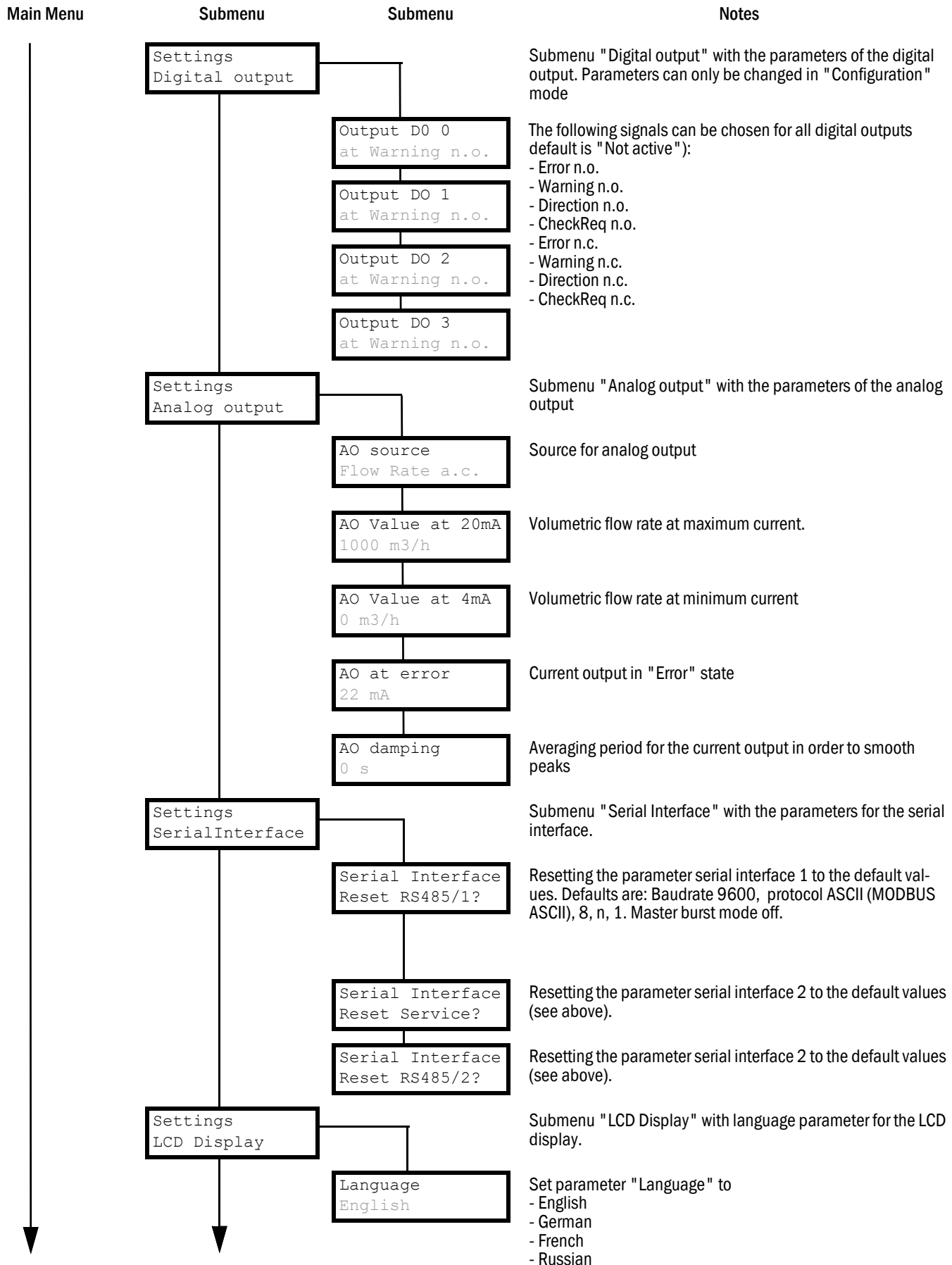

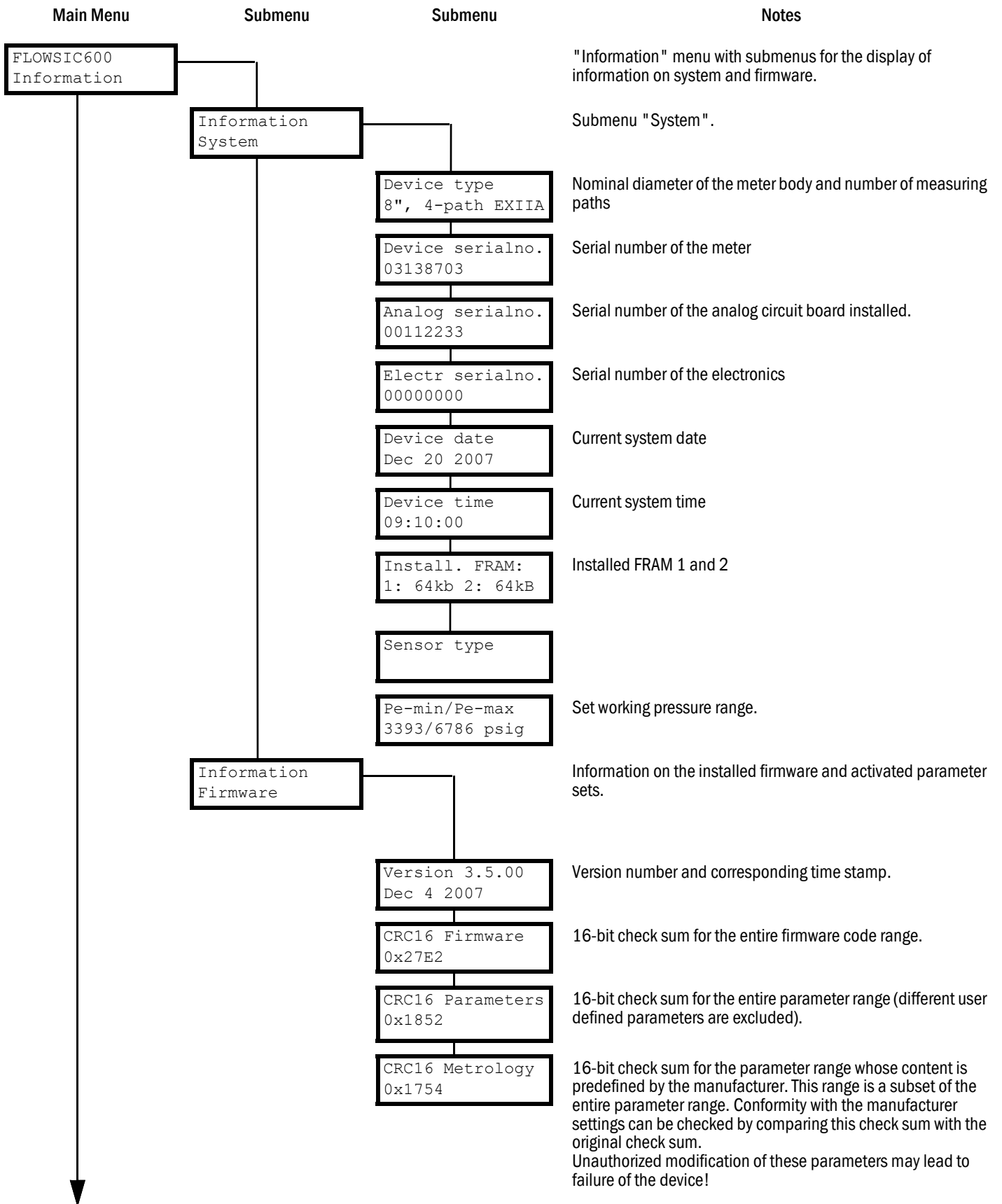

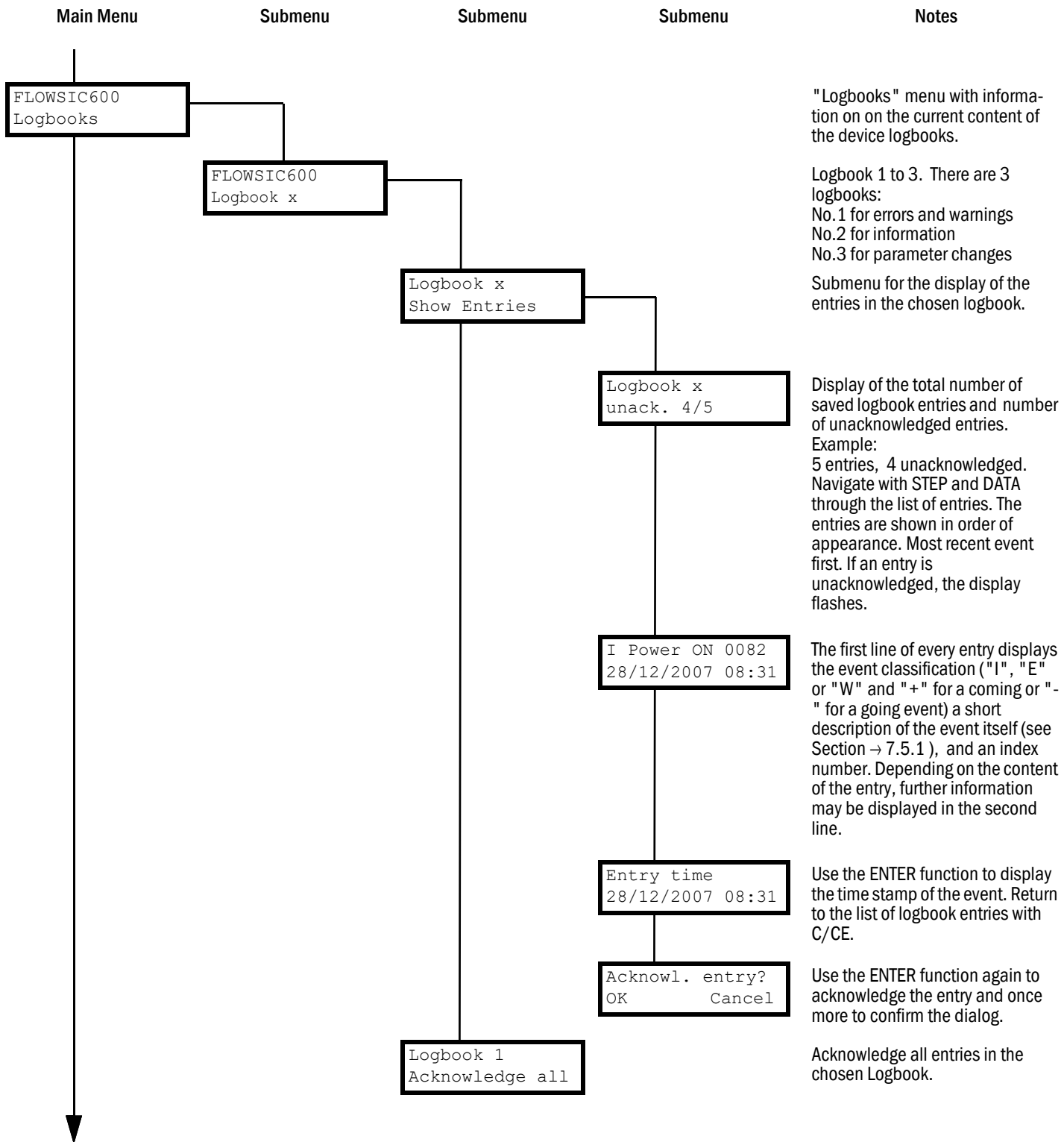

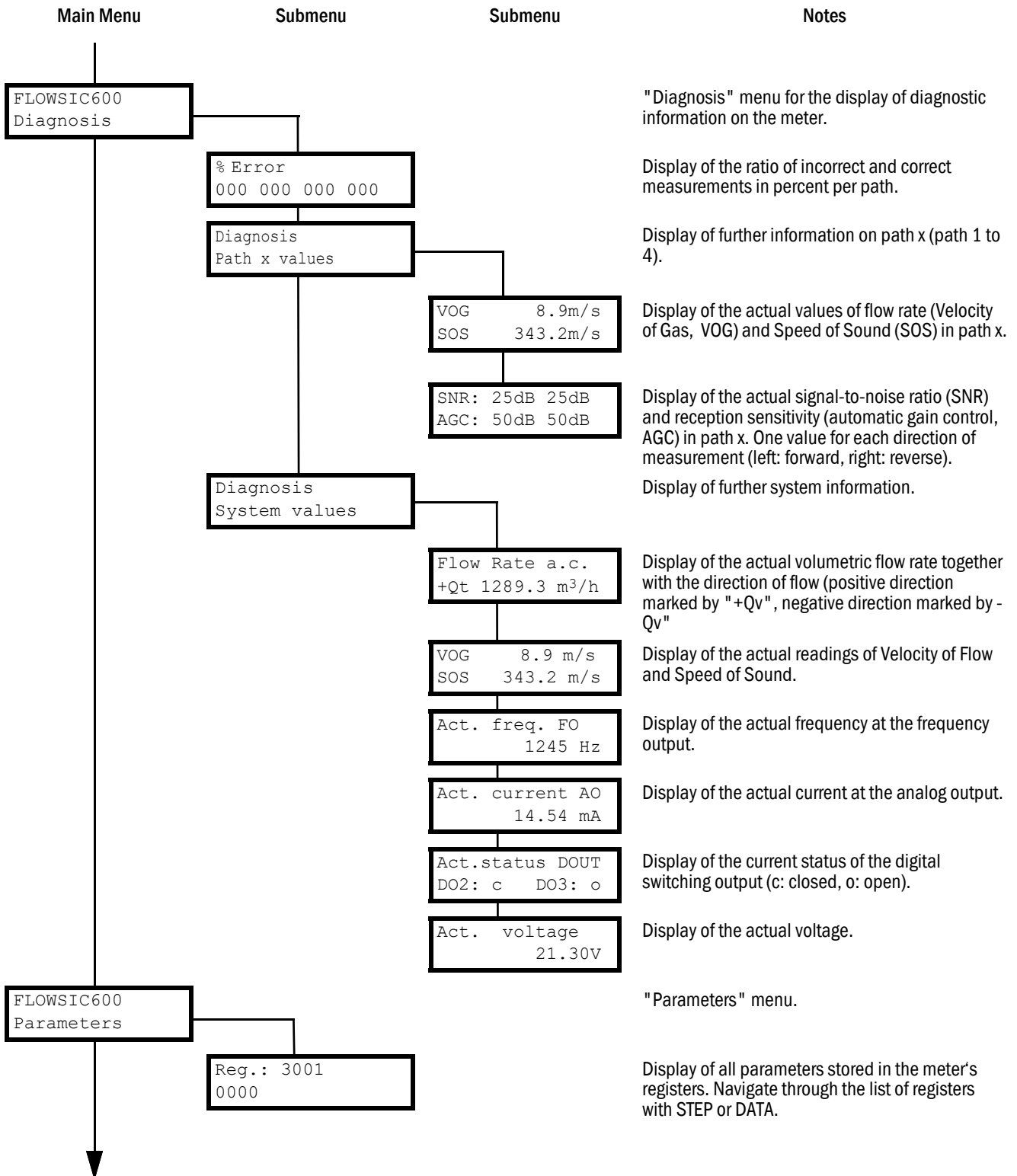

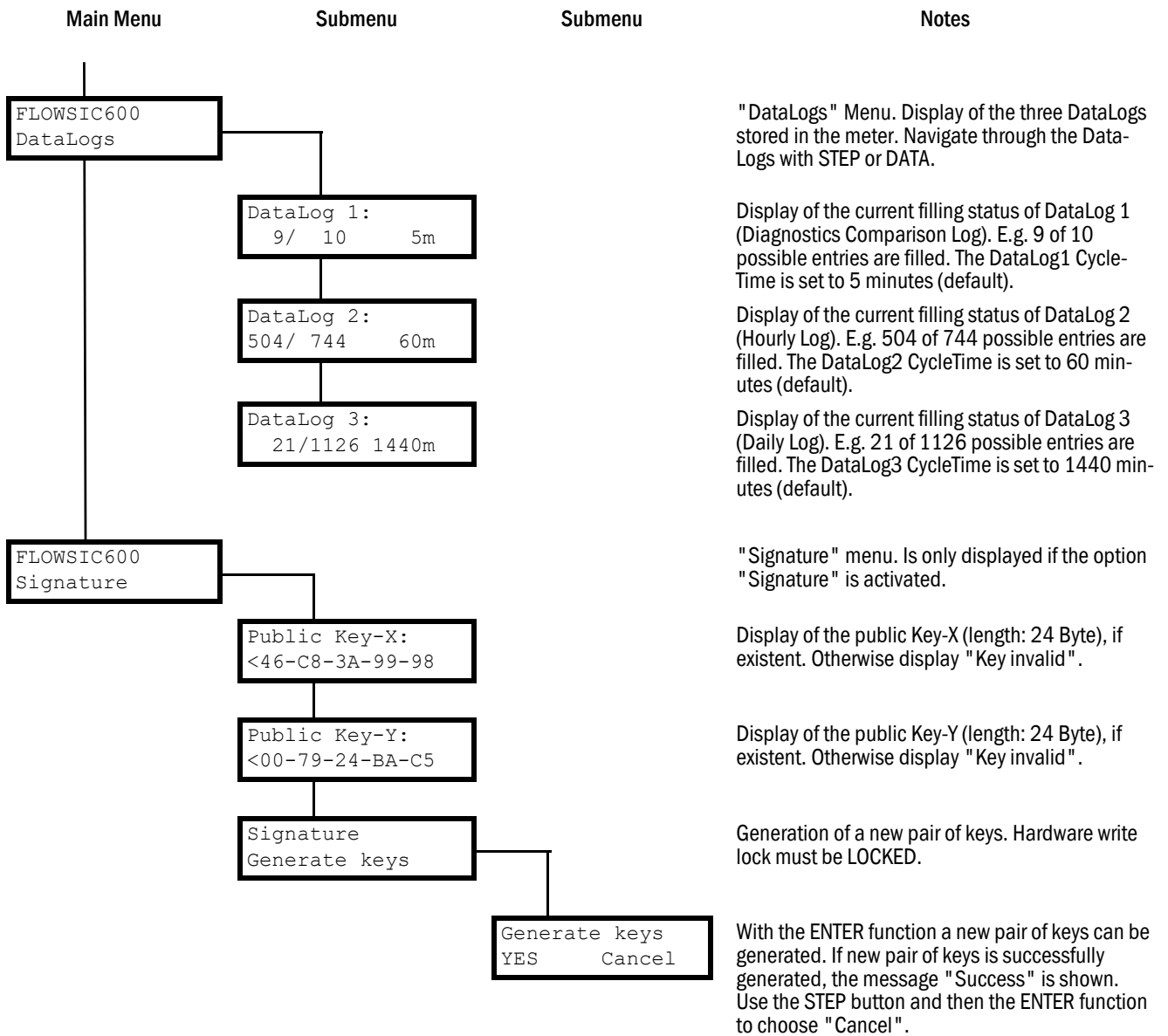

7.4.3 **Display of measured values**

The default values to be displayed on the two line LCD can be assigned using FLOWgate™. The values can be assigned to the desired page and line of the standard display. The two display pages alternate every 5 seconds.

7.4.4 Data editing in Configuration Mode

In configuration parameters which are relevant to the commissioning or operation of the meter can be modified. If the Parameter write lock is LOCKED, it must be set to the "UNLOCKED" before parameter modification.

Navigate to the parameter and use the ENTER function to begin editing.

Options depending on the type of data:

- Integer: 0, 1, 2, 3, 4, 5, 6, 7, 8, 9, sign
- Floating point: 0, 1, 2, 3, 4, 5, 6, 7, 8, 9, space, decimal point, sign
- List of registers: List of all registers (which are plausible for this parameter)

Example: Switching the meter to Configuration Mode and editing a parameter, e.g. the impulse factor.

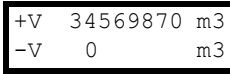
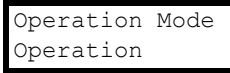
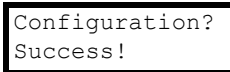
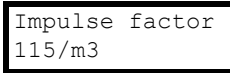
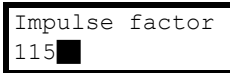
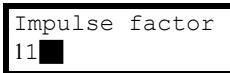
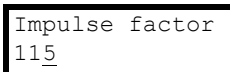
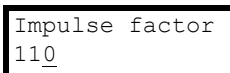
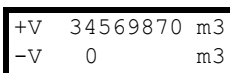
Action	Buttons	Display
Standard display	-	
Enter menu	ENTER	
Edit parameter "Operation Mode"	ENTER	
Confirm change to "Maintenance Mode"	ENTER -> Change mode	
Scroll through the menu structure to the parameter you want to edit	(ENTER, STEP, DATA)	
In this example, the impulse factor is edited		
Select the parameter	ENTER	
Move cursor to the digit that you want to change	1 * STEP	
Put in edit mode	2 * DATA	
Enter desired value	x * DATA	
Confirm new value	ENTER	
Return to standard display	3 x CE/C	

7.4.5 **Resetting the error volume counters**

To reset the error volume counters, password level "authorized operator" is required.

```
+Ef      70 m³
-Ef      0 m³
```

Select the error volume display. Use the ENTER function to enter the dialog for resetting the error volume counters.

<ENTER>

```
Counter reset
OK      Cancel
```

Confirm the reset with the ENTER function. The error volume counter will be reset to zero. The reset will be recorded in the logbook. Press C/CE to cancel the reset.

<ENTER>

```
+EV      0 m³
-EV      0 m³
```

7.4.6 **Acknowledging a battery replacement**



Description of a battery replacement, see Service Manual

After a battery replacement the following message flashes on the LCD-display:

```
INFORMATION 1030
LifeSpan Battery
```

Since date and time of the FLOWSIC600 are invalid after switching the meter back on, they have to be set to valid values. We recommend to use the clock synchronization function of FLOWgate™.

After setting date and time, the LCD message can be acknowledged. The acknowledgment sets the life span cycle of the new battery to zero. Complete the following step at the LCD-display:

Press DATA.

```
INFORMATION 1030
LifeSpan Battery
```

Apply the ENTER function two times

```
Device state
E:x W:x I:x
```

Apply the ENTER function

```
Battery replaced
OK      Cancel
```

(This message becomes visible for just one second.)

WARNING: Explosion Hazard

- ▶ Do not replace the battery unless power has been removed or the area is known to be non-hazardous.
- ▶ of components may impair intrinsic safety.
- ▶ Replacement battery must be of type Panasonic BR 2032.

7.5

Logbooks**1** Classification of logbook entries

The entries are distinguished into three classes and identified by the initial character in the first line.

- "I" information
- "W" warning
- "E" error/ malfunction

2 Type of occurrence

- "+" point of time identifying the beginning of a status
- "-" point of time identifying the end of a status

7.5.1

Overview of event entries in meter logbooks

Message No. on LCD	Details	Logbook	LCD Text
Custody logbook [1]			
3002	NO DSP communication	1	E+System 0001 NO DSP-Communic.
			E-System 0001 NO DSP-Communic.
3003	Measurement invalid	1	E+DSP 0001 Reading invalid
			E-DSP 0001 Reading invalid
3004	Firmware CRC invalid	1	E+Firmware 0001 CRC invalid
			E-Firmware 0001 CRC invalid
3005	Parameter CRC invalid	1	E+Parameter 0001 CRC invalid
			E-Parameter 0001 CRC invalid
3006	Parameter out of range	1	E+Parameter 0001 #XXXX range error
			E-Parameter 0001 #XXXX range error
3007	Failure during storage of path compensation parameter	1	E+PathComp. 0001 Storage error
			E+PathComp. 0001 Storage error
3008	Meter clock time invalid	1	E+System 0001 ClockTime inval.
			E-System 0001 ClockTime inval.
3009	Custody logbook [1] overflow	1	E+Logbook 1 0001 Overflow
			E-Logbook 1 0001 Overflow
3011	CRC volume counter (a.c) invalid	1	E+Count.ac 0001 CRC invalid
			E-Count.ac 0001 CRC invalid
3012	CRC volume counter (n.c) invalid	1	E+Count.sc 0001 CRC invalid
			E-Count.sc 0001 CRC invalid
3013	Transit time mode activated	1	E+System 0001 TransitTimeMode
			E-System 0001 TransitTimeMode

Message No. on LCD	Details	Logbook	LCD Text
3014	No signature key	1	E+System 0001 No signature key
			E-System 0001 No signature key
2001	Path failure	1	W+PathError 0001 Path 1 2 3 4
			W-PathError 0001 All paths OK
2002	No HART communication to temperature transmitter	1	W+HART T 0001 No communication
			W-HART T 0001 No communication
2003	No HART communication to pressure transmitter	1	W+HART P 0001 No communication
			W-HART P 0001 No communication
2004	Maximum pulse output frequency exceeded (6kHz)	1	W+PulseOut 0001 6000 Hz exceeded
			W-PulseOut 0001 6000 Hz exceeded
2005	EVC parameter invalid	1	W+EVC 0001 EVC para.invalid
			W+EVC 0001 EVC para.invalid
2006	EVC hardware error	1	W+EVC 0001 EVC module error
			W+EVC 0001 EVC module error
1001	Flow meter power ON	1	I Power ON 0001 dd/mm/yy mm:ss
1002	Meter clock adjusted	1	I Set Time 0001 dd/mm/yy mm:ss
1003	Configuration Mode active	1	I+Meas.Mode 0001 Configurat. ON 1
			I-Meas.Mode 0001 Measurement ON 1
1004	Firmware changed	1	I Update FW 0001 3104 -> 3200
1007	Custody logbook [1] erased and initialized	1	I Logbook 1 0001 Reset and Init
1014	Overflow volume counter (a.c.)	1	I Count.ac 0001 Overflow
1015	Overflow volume counter (s.c.)	1	I Count.sc 0001 Overflow
1016	Error volume counter cleared	1	I Reset E 0001 01/01/07 10:47
1017	All volume counters cleared	1	I Reset V 0001 01/01/07 10:47

Message No. on LCD	Details	Logbook	LCD Text
1027	Initialization error → Default parameter loaded	1	I+InitError 0001 DefaultParaLoad
			I-InitError 0001 DefaultParaLoad
1029	Air test mode activated	1	I+Airtest 0001 Active
			I-Airtest 0001 Not active
Warning logbook [2]			
1008	Warning logbook [2] erased and initialized	2	I Logbook 2 0001 Reset and Init
1010	Warning logbook [2] overflow	2	I+Logbook 2 0001 Overflow
			I-Logbook 2 0001 Overflow
1018	DataLog 1 cleared	2	I DataLog 1 0001 Reset
1019	DataLog 2 cleared	2	I DataLog 2 0001 Reset
1020	DataLog 3 cleared	2	I DataLog 3 0001 Reset
1021	DataLog 1 overflow	2	I+DataLog 1 0001 Overflow
			I-DataLog 1 0001 Overflow
1022	DataLog 2 overflow	2	I+DataLog 2 0001 Overflow
			I-DataLog 2 0001 Overflow
1023	DataLog 3 overflow	2	I+DataLog 3 0001 Overflow
			I-DataLog 3 0001 Overflow
1024	DatenLog 1 CRC error	2	I+DataLog 1 0001 CRC invalid
			I-DataLog 1 0001 CRC invalid
1025	DatenLog 2 CRC error	2	I+DataLog 2 0001 CRC invalid
			I-DataLog 2 0001 CRC invalid
1026	DataLog 3 CRC error	2	I+DataLog 3 0001 CRC invalid
			I-DataLog 3 0001 CRC invalid

Message No. on LCD	Details	Logbook	LCD Text
1028	Customer limit exceeded	2	I+Userlimit 0001 Limit XXXXXXXXXXX
			I-Userlimit 0001 Limits OK
Parameter logbook [3]			
1005	Parameter changed	3	I Parameter 0001 Change Reg3001
1006	All parameters to default (Reset)	3	I Parameter 0001 Reset all
1009	Parameter logbook [3] erased and initialized	3	I Logbook 3 0001 Reset and Init
1011	Parameter logbook [3] overflow	3	I+Logbook 3 0001 Overflow
			I Logbook 3 0001 Overflow

7.5.2 Acknowledging a logbook entry on the LCD display

I Power ON 001 28/12/2007 12:13 <ENTER>
Entry time 28/12/2007 12:13

Press STEP or DATA to select an entry which has not yet been acknowledged (display is flashing). Activate the ENTER function to display the corresponding time stamp of the event. The display is still flashing. Activate the ENTER function again in order to acknowledge the entry (display will stop flashing). Return to the list of logbook entries by pressing C/CE.



It is recommended that FLOWgate™ be used for the acknowledgment of logbook entries due to the user-friendly access it provides.

7.6

SPU terminal assignment

Connection in accordance with ATEX IIA

Figure 54

Terminal assignment in accordance with ATEX IIA

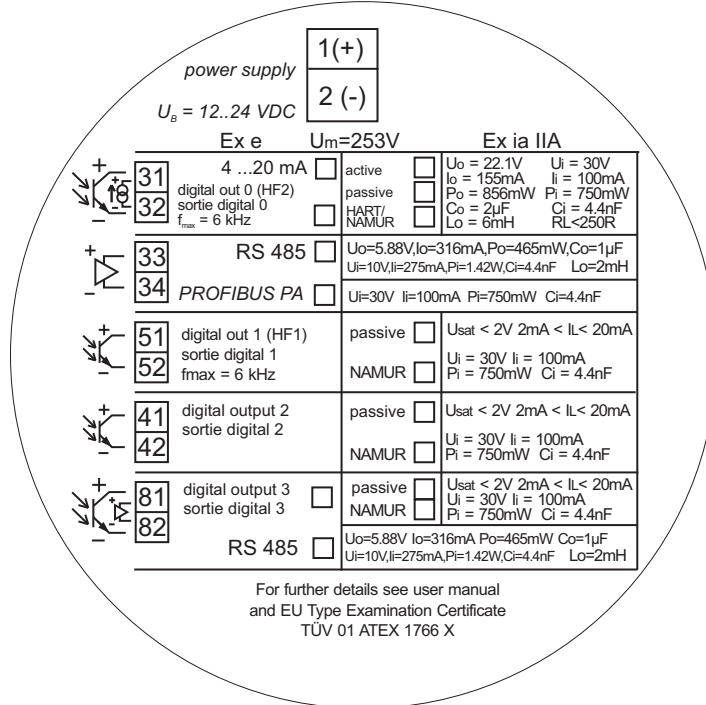

Connection in accordance with ATEX IIC

Figure 55

Terminal assignment in accordance with ATEX IIC

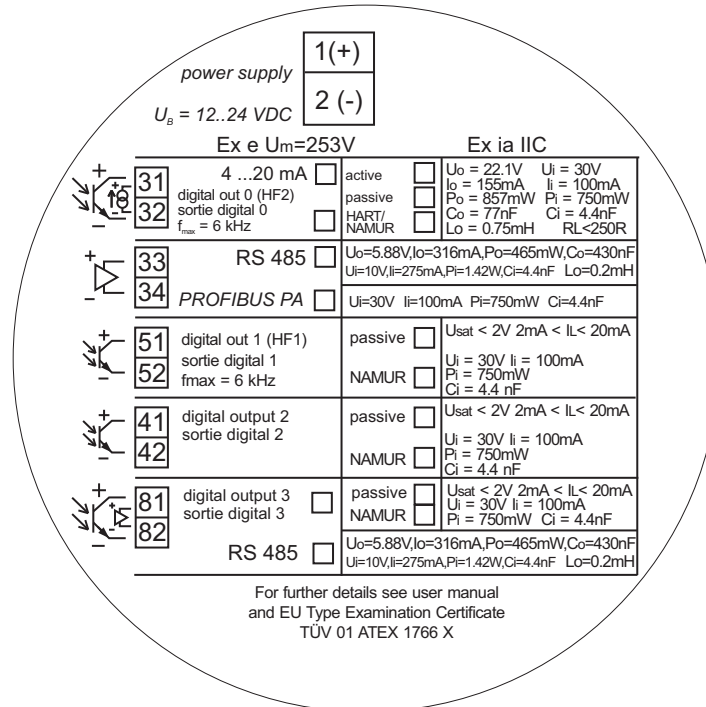

Connection in accordance with ATEX /IECEX IIA

Figure 56 Terminal assignment in accordance with ATEX IIA

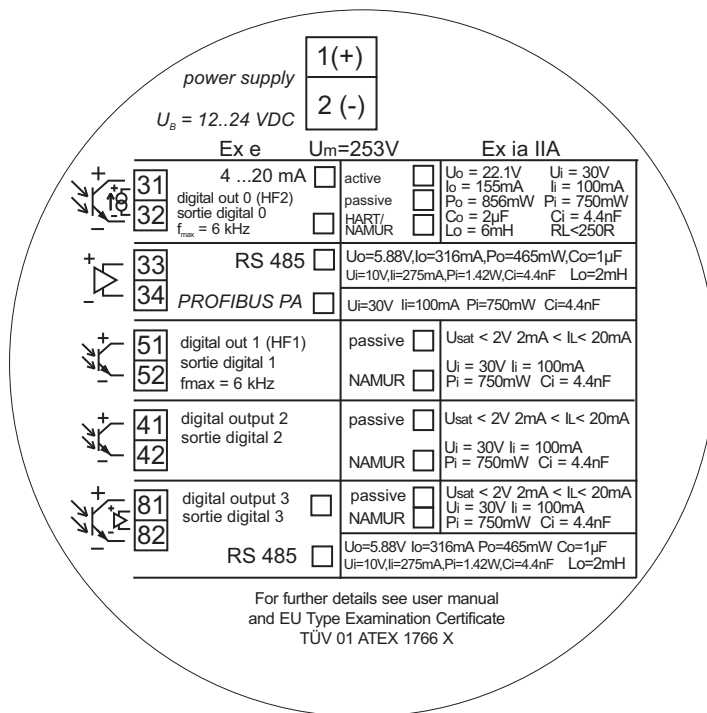

Connection in accordance with ATEX /IECEX IIC

Figure 57 Terminal assignment in accordance with ATEX IIC

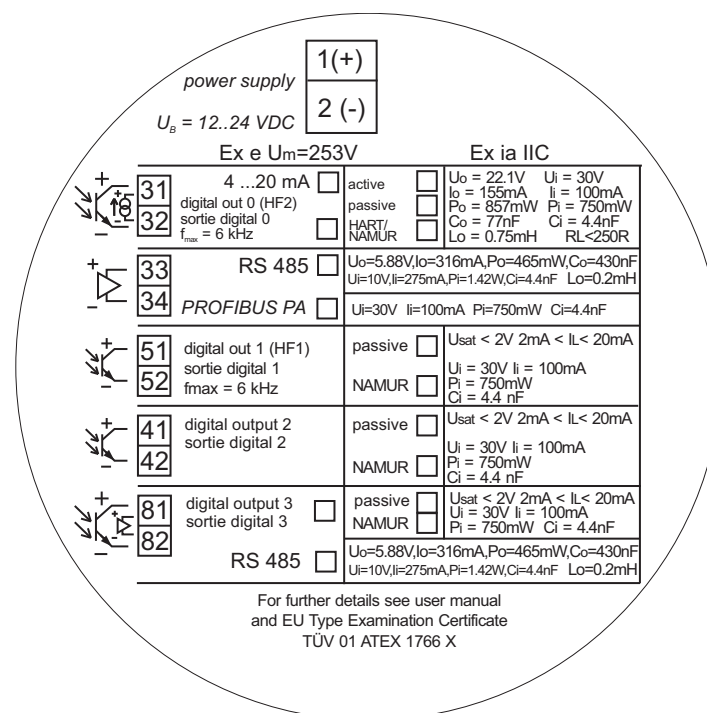

For CSA SPU Assignment → S. 146, »Control drawing 9418408 (page 4)« and following.

7.7

Connection diagrams for operating the FLOWSIC600 in hazardous areas in accordance with North American Requirements (NEC, CEC)

Figure 58 Control drawing 9418408 (page 1)

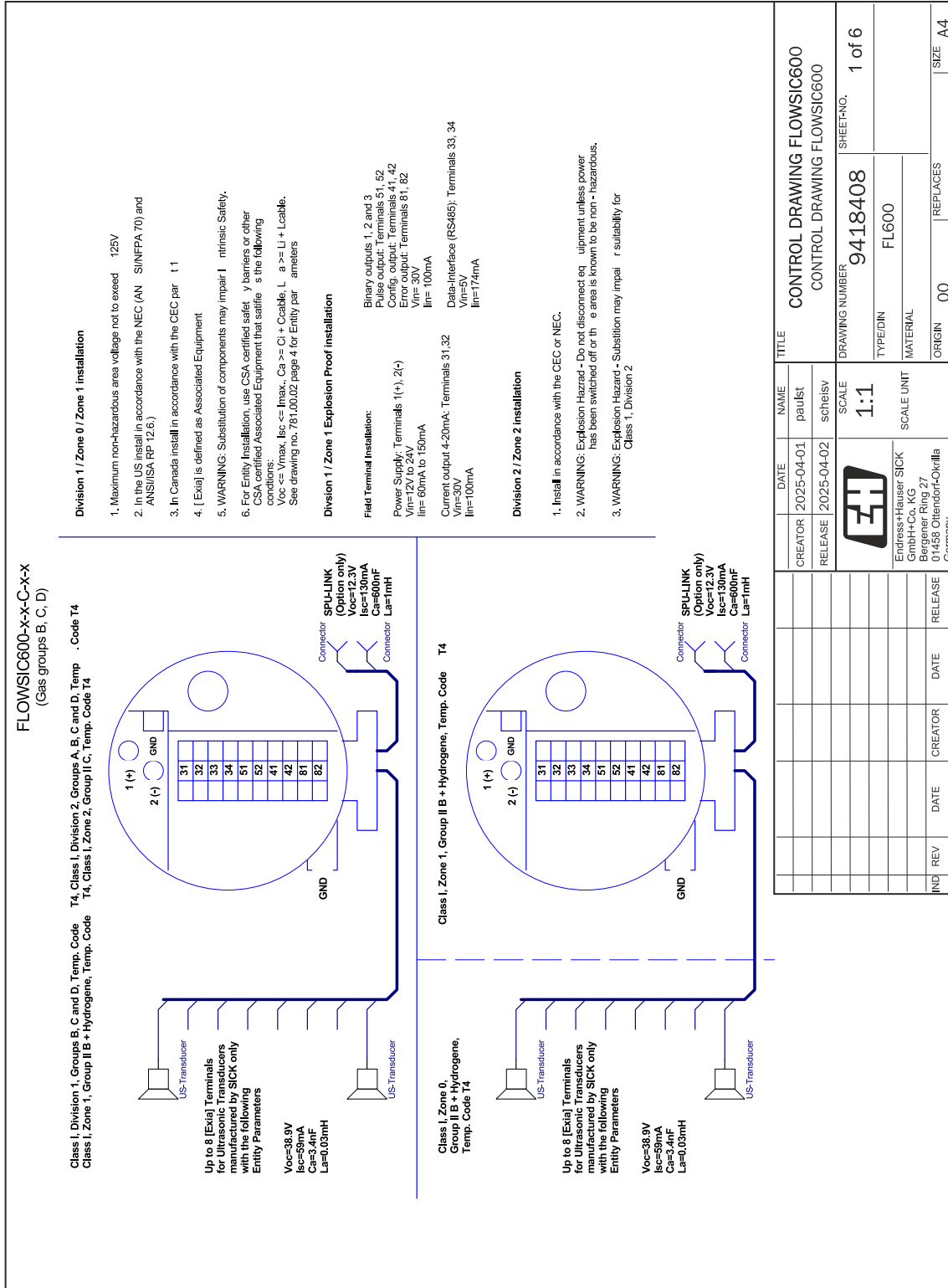
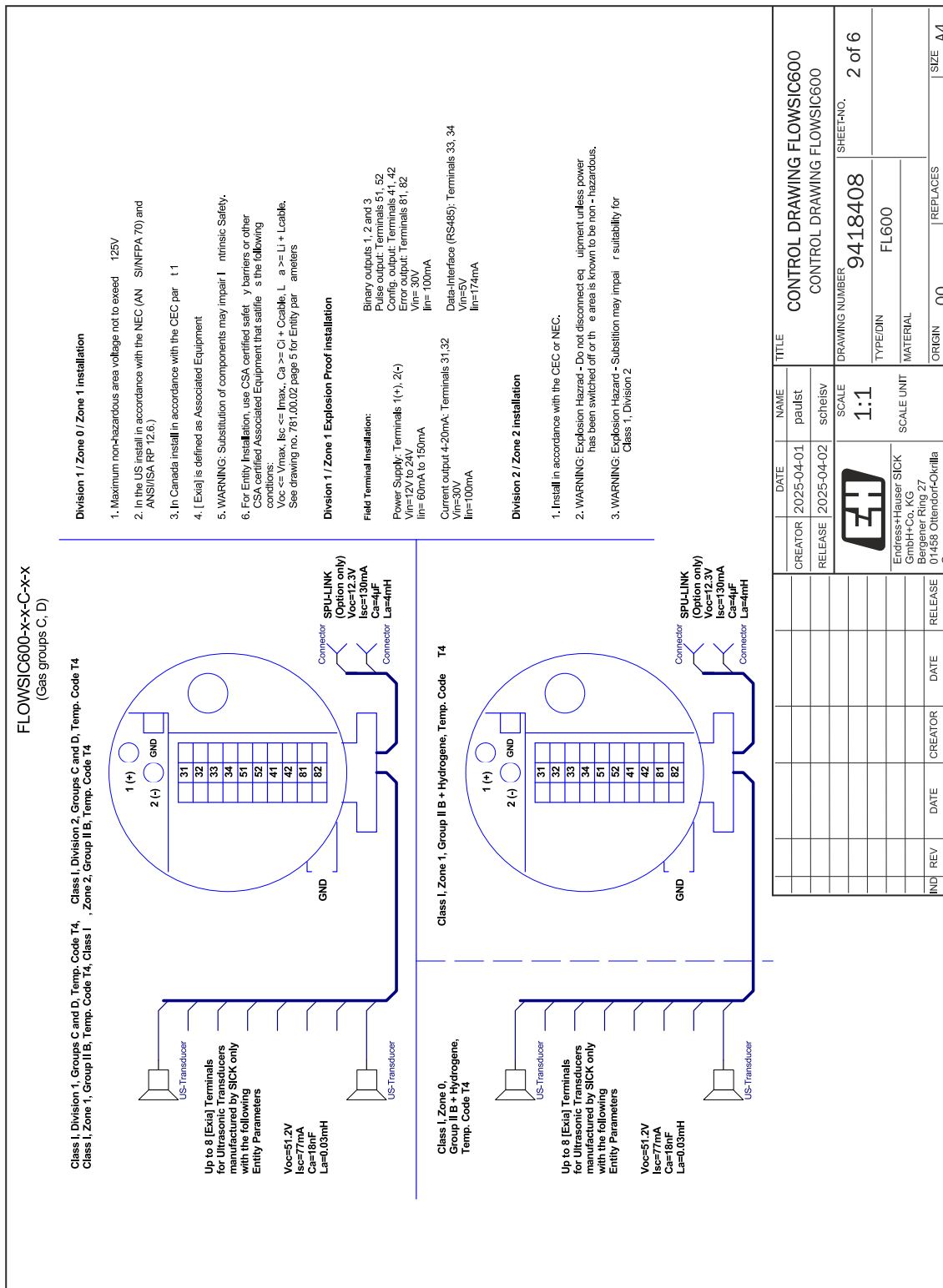

Figure 59 Control drawing 9418408 (page 2)



IND	REV	DATE	CREATOR	DATE	RELEASE

DATE	NAME	TITLE
2025-04-01	paulist	CONTROL DRAWING FLOWUSIC600
2025-04-02	scheiss	CONTROL DRAWING FLOWUSIC600
	SCALE	DRAWING NUMBER
	1:1	9418408
	SCALE UNIT	SHEET NO. 2 of 6
		TYPE/IDIN
		FL600
		MATERIAL
		ORIGIN 00
		REPLACES
		SIZE A4

CREATOR: 2025-04-01 paulist
 RELEASE: 2025-04-02 scheiss

 Endress+Hauser SICK GmbH+Co. KG
 Bergerstr. 27
 01468 Osterdorf-Okulla
 Germany

The reproduction, adaptation, distribution and utilization of this document, in part or in entirety, as well as the communication of contents to others without explicit authorization is prohibited. Any violations thereof will lead to prosecution. Orders will be fulfilled for the payment of damages. All rights reserved especially for the payment of damages. All rights reserved especially for the payment of damages. All rights reserved especially for the payment of damages.

© Endress+Hauser SICK GmbH+Co. KG All rights reserved.

7.8 Wiring examples

7.8.1 Intrinsically safe installation

Figure 64 FLOW SIC600 intrinsically safe installation

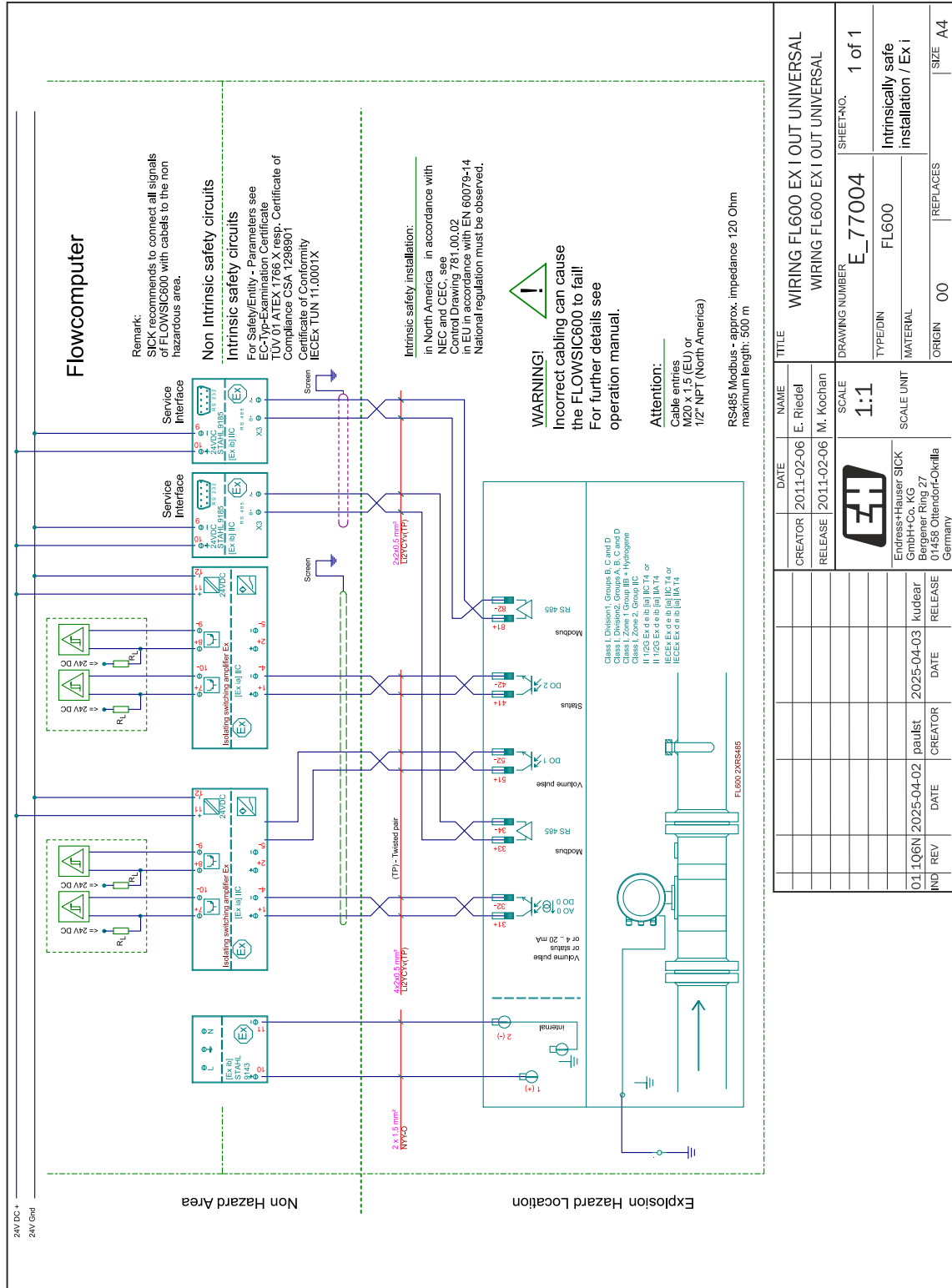

7.8.2 Non-intrinsically safe installation

Figure 65 FLWSIC600 non-intrinsically safe installation

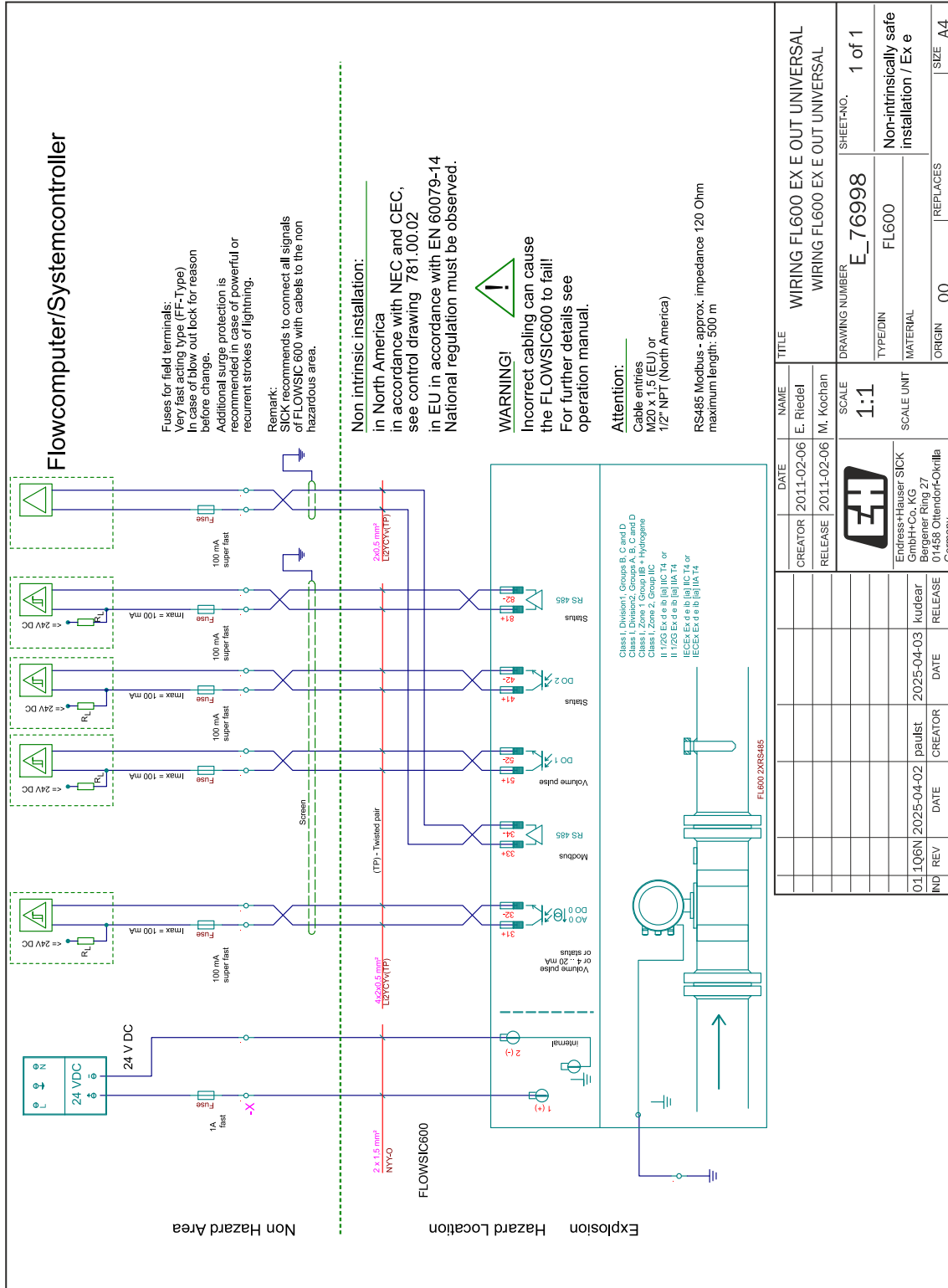

7.9

Sealing plan

Figure 66 Sealing plan, part 1 (cast version)

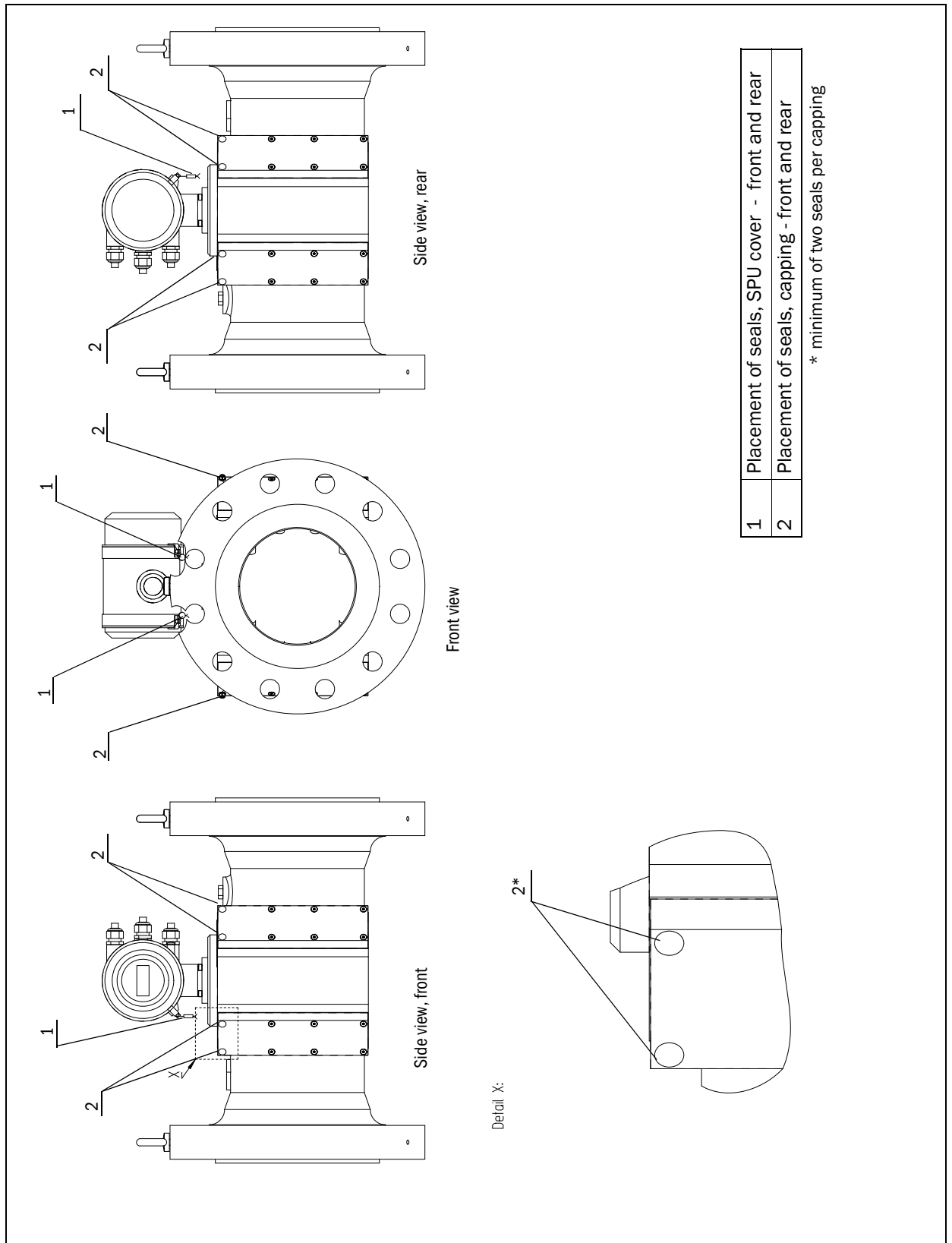

Figure 67 Sealing plan, part 2 (cast version)

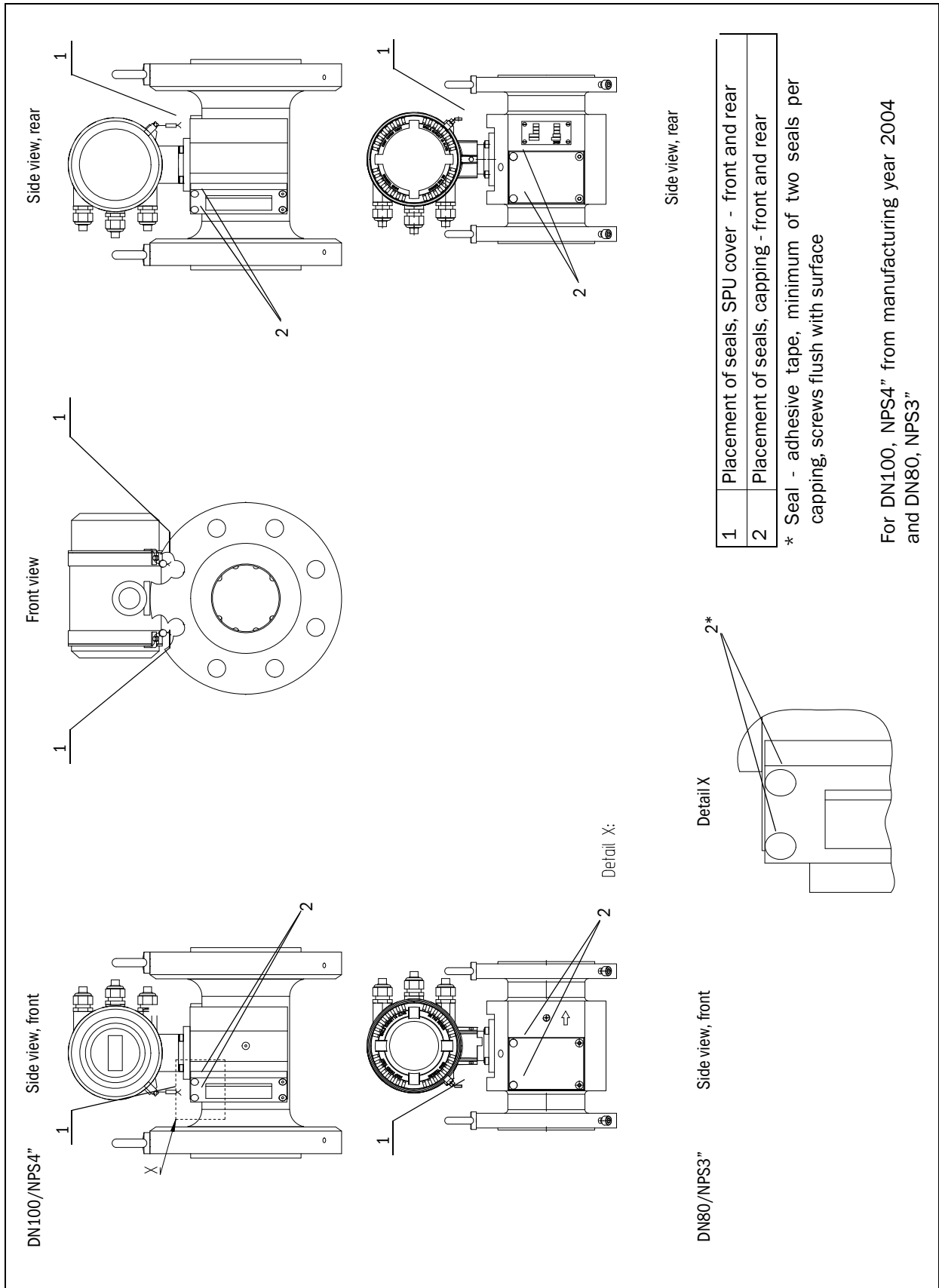
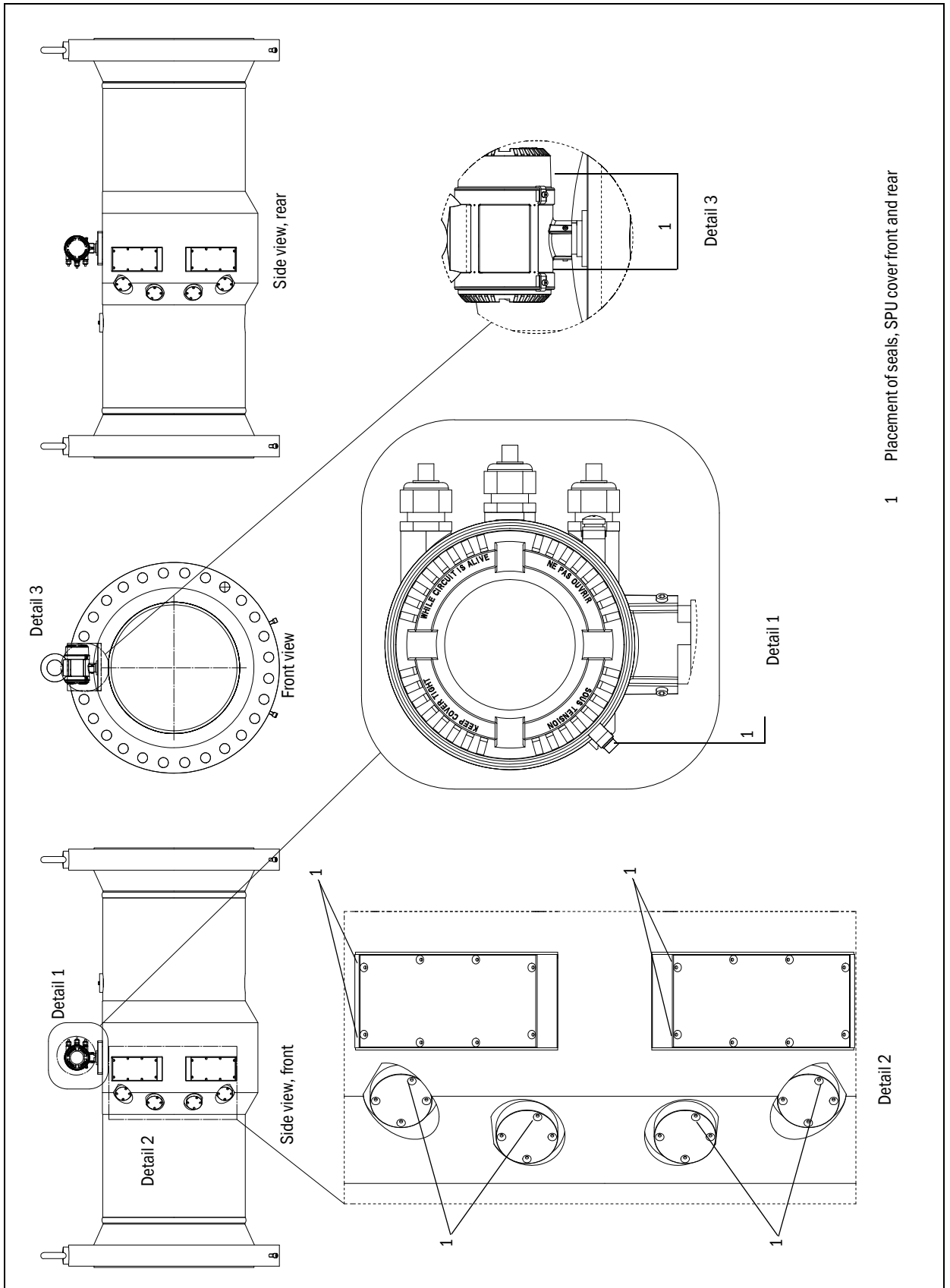

Figure 68 Sealing plan, part 3 (forged version)



1 Placement of seals, SPU cover front and rear

Figure 69 Sealing plan, part 4

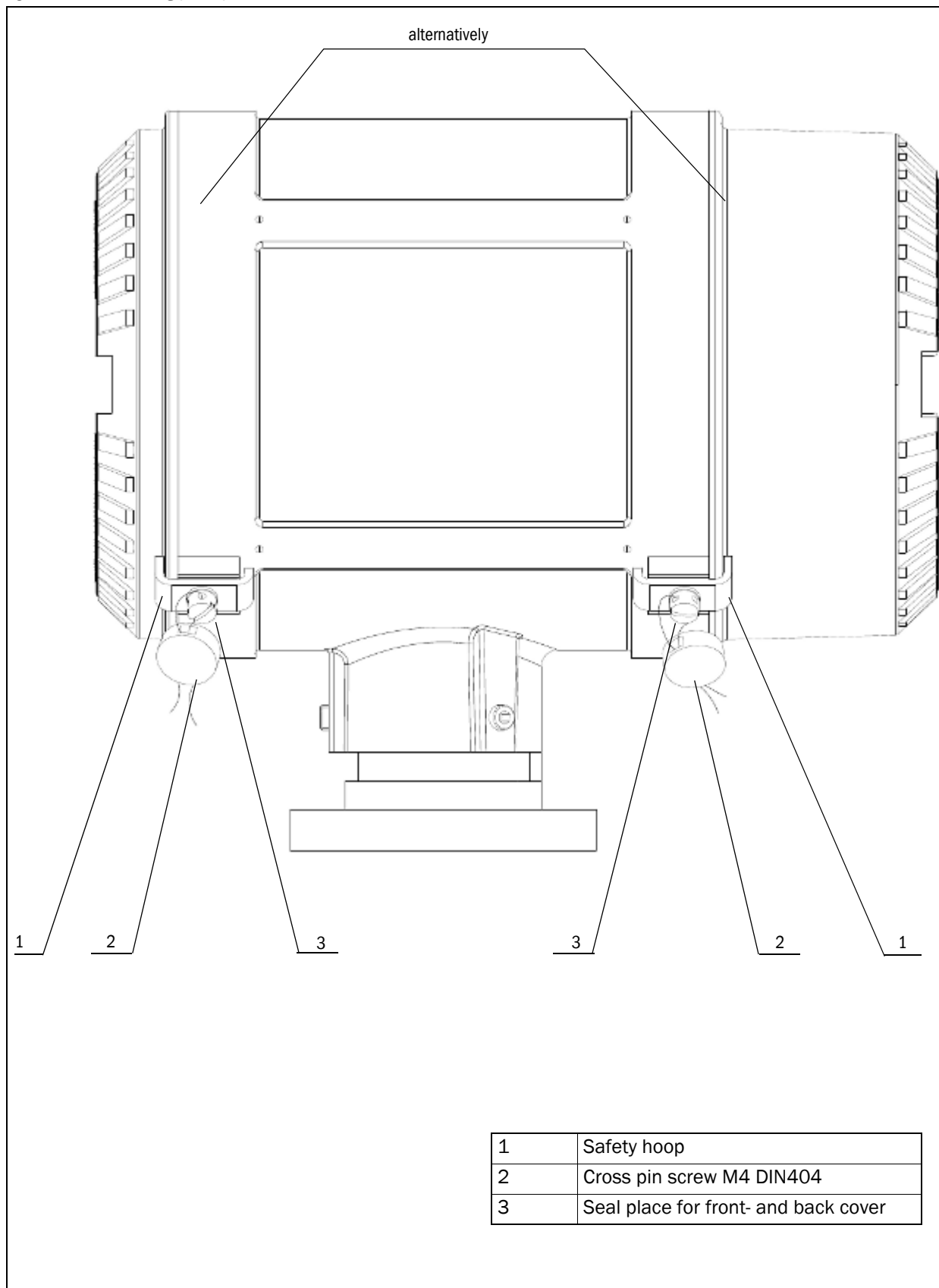

Figure 70

Examples: Main type plates on the signal processing unit

ATEX

Made in Germany		Endress + Hauser	
FLOW SIC600		Endress+Hauser SICK GmbH+Co, KG Bergener Ring 27, 01458 Ottendorf-Okrilla, Germany	
Type code	00	80	
Serial no.	02		
Part no.	01		
U _{nom}	12...24 V DC =	II 1/2 (1) G IP66 / IP67 Ex ia/db eb ia [ia Ga] 12 T4...T1 Ga/Gb TÜV 01 ATEX 1766 X	WARNING: Read operation instructions!
I _{max}	150 mA		
Q _{min}	09 25		Date: 03
Q _i	17 28		
Q _{max}	08 24		
T _s	04 05 20		
T _p	06 07 21		
C _p	10 26		
P _s	see display		
Date	11	18 ID: 02.1	

IECEX

Made in Germany		Endress + Hauser	
FLOW SIC600		Endress+Hauser SICK GmbH+Co, KG Bergener Ring 27, 01458 Ottendorf-Okrilla, Germany	
Type code	00	80	
Serial no.	02		
Part no.	01		
U _{nom}	12...24 V DC =	IP66/IP67 Ex d e ib [ia 12 Ga] 12 T4 Ga/Gb IECEX TUN 11.0001X	WARNING: Explosion hazard Read operation instructions before installation.
I _{max}	150 mA		
U _{in}	253 V		Date: 03
Q _{min}	09 25		
Q _i	17 28		
Q _{max}	08 24		
T _s	10 26		
T _p	04 05 20		
C _p	06 07 21		
P _s	see display	18 ID: 02.1	

CSA - IIC; BCD

Made in Germany		Endress + Hauser	
FLOW SIC600		Endress+Hauser SICK GmbH+Co, KG Bergener Ring 27, 01458 Ottendorf-Okrilla, Germany	
Type code	00	80	
Serial no.	02		
Part no.	01		
U _{nom}	12...24 V DC =	C _{US} IP66/IP67 CII, Div 1, Gp B, C, D, T4 Provide IS output for CII, Div 1, Gp B, C, D CII, Zn 1, Gp IIB + H, T4 Provide IS output for CII, Zn 1, Gp IIB + H, T4 CII, Div 2, Gp A, B, C, D, T4 Provide IS output for CII, Div 2, Gp A, B, C, D CII, Zn 2, Gp IIC T4 Provide IS output for CII, Zn 2, Gp IIC T4 CSA02CA1298901X [Ex ia] associated equipment	WARNING: Explosion hazard Substitution of components may impair intrinsic safety. Provides intrinsically safe circuits when installed per drawing number 9418408. Seal within 18 inches of enclosure for non intrinsically safe connection. Keep cover tight while circuits are alive. AVERTISSEMENT: Risque d'explosion La substitution de composants peut compromettre la sécurité intrinsèque. Fournit des circuits à sécurité intrinsèque lorsqu'il est installé conformément au numéro de dessin 9418408. Sceller à moins de 18 pouces de l'enceinte pour une connexion non intrinsèquement sûre. Ne pas ouvrir sous tension.
I _{max}	150 mA		
Q _{min}	09 25		Date: 03
Q _i	09 25		
Q _{max}	08 24		
T _s	04 05 20		
T _p	06 07 21		
C _p	10 26		
P _s	see display		
Date	11	18 ID: 02.1	

CSA - IIA; D

Made in Germany		Endress + Hauser	
FLOW SIC600		Endress+Hauser SICK GmbH+Co, KG Bergener Ring 27, 01458 Ottendorf-Okrilla, Germany	
Type code	00	80	
Serial no.	02		
Part no.	01		
U _{nom}	12...24 V DC =	C _{US} IP66/IP67 CII, Div 1, Gp D, T4 Provide IS output for CII, Div 1, Gp D CII, Zn 1, Gp IIA T4 Provide IS output for CII, Zn 1, Gp IIA T4 CII, Div 2, Gp D, T4 Provide IS output for CII, Div 2, Gp D CII, Zn 2, Gp IIA T4 Provide IS output for CII, Zn 2, Gp IIA T4 CSA02CA1298901X [Ex ia] associated equipment	WARNING: Explosion hazard Substitution of components may impair intrinsic safety. Provides intrinsically safe circuits when installed per drawing number 9418408. Seal within 18 inches of enclosure for non intrinsically safe connection. Keep cover tight while circuits are alive. AVERTISSEMENT: Risque d'explosion La substitution de composants peut compromettre la sécurité intrinsèque. Fournit des circuits à sécurité intrinsèque lorsqu'il est installé conformément au numéro de dessin 9418408. Sceller à moins de 18 pouces de l'enceinte pour une connexion non intrinsèquement sûre. Ne pas ouvrir sous tension.
I _{max}	150 mA		
Q _{min}	09 25		Date: 03
Q _i	09 25		
Q _{max}	08 24		
T _s	04 05 20		
T _p	06 07 21		
C _p	10 26		
P _s	see display		
Date	11	18 ID: 02.1	

Variable	Description
00	device type
01	part number
02	serial number
02.1	ID number (according to 9350693)
03	year (MM/YYYY)
04	min. ambient temperature
05	max. ambient temperature
06	min. gas temperature
07	max. gas temperature
08	max. flowrate
09	min. flowrate
10	k-factor
11	-
12	gasgroup Ex
13	model number
14	type approval
15	"Calibrated for for natural gas and air." or "Calibrated for natural gas, not for low pressure." or "empty"
16	year short (MM/YYYY)
17	transition flowrate
18	Datamatrix-Code 02.1; Formate (according to 9350693)
19	MPE declaration
20	unit of 04
21	unit of 05
22	unit of 06
23	unit of 07
24	unit of 08
25	unit of 09
26	unit of 10
27	unit vol.
28	unit of 17
29	optional text for ATEX and $T_p > 91^\circ\text{C}$ and 100°C $T_p - 41 \dots 100^\circ\text{C} @ T_3 \dots T_1$; if 21 = $^\circ\text{C}$ $T_p - 41 \dots 212^\circ\text{F} @ T_3 \dots T_1$; if 21 = $^\circ\text{F}$
80	Datamatrix-Code 01(P) + 02(S); Formate P P P P P P S S S S S S S S

Figure 71 Example: Type plate on the meter body

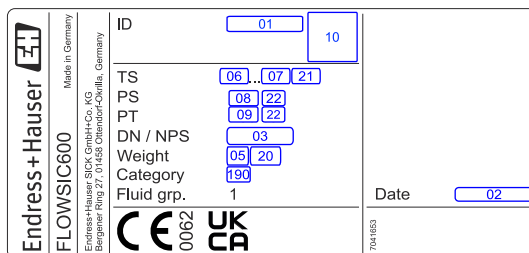

Variable	Description
01	serial number / ID
02	date (MM/YYYY)
03	meter size (XXX/XX")
04	-
05	min. design temperature
06	max. design temperature
07	max. gas temperature
08	max. design pressure
09	test pressure
10	Datamatrix-Code 01(M) + 02(S) Formate MMMMMMMSSSSSSS
20	unit of weight 04
21	unit of temperature 05/06
22	unit of pressure 07/08
190	pressure equipment category

8029791/1VT8/V1-1/2026-06

www.addresses.endress.com
