

## GM700

# In-situ laser gas analyzer for emission monitoring and process measurement

### Efficient process analysis – even under difficult conditions

- In-situ measurement directly in the process for accurate measured values
- Probe and cross-duct versions to match the requirements of your measuring task perfectly
- High reliability during operation
- Can also be used in harsh ambient conditions
- Detects quick and short-term process fluctuations

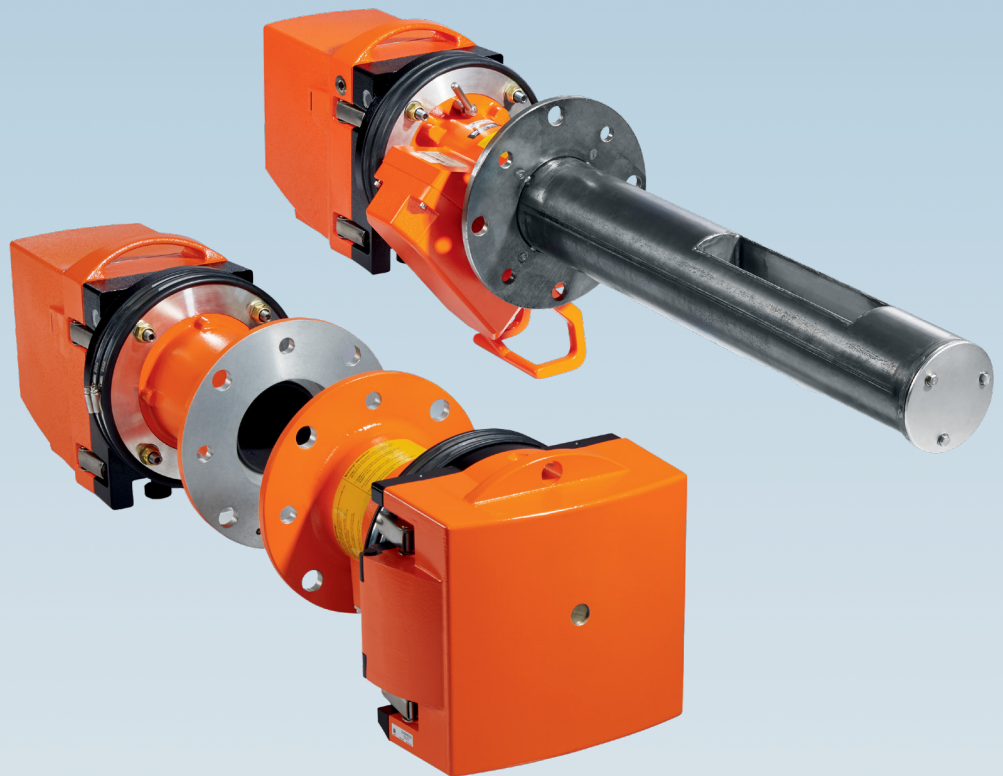

# Robust analyzer solution for industrial gas measurement applications

Measuring difficult, selective gas components such as ammonia ( $\text{NH}_3$ ), hydrogen fluoride (HF), hydrogen chloride (HCl), carbon monoxide (CO) and water ( $\text{H}_2\text{O}$ ) is a major challenge for process analysis and emission monitoring. The GM700 in-situ gas analyzer opens up new options here. With unparalleled flexibility – without the need for test gases.



## Technology and principle of operation

The GM700 gas analyzer operates reliably and efficiently. Thanks to its innovative in-situ measurement technology, the analyzer can be mounted at the measurement location directly in the duct through which the gas flows. The benefits: time and cost savings thanks to simple installation and commissioning, low maintenance requirements, and very short response times. The GM700 delivers a

high-resolution measurement using direct laser spectroscopy (see below) with a precisely adjusted spectral line. The result: fast and undistorted recording of measuring gas concentrations without time-consuming gas extraction, conditioning, and cost-intensive transportation. Gas components that can be measured by the GM700 include:  $\text{NH}_3$ , HF, HCl, CO and  $\text{H}_2\text{O}$ .

### Laser spectroscopy (tunable diode laser spectroscopy, TDLS)

In laser spectroscopy, the laser beam from the sender is sent through the gas to be measured to the reflector. From there, it is reflected back to a sensitive detector (photo diode) in the sender/receiver unit. The wavelength of the laser diode is adjusted to a spectral line of the sample gas components. This is scanned by modulating the wavelength and recorded by the photo diode of the detector. A signal evaluation then provides the gas concentration based on the wavelength-specific absorption of the measurement signal. The TDLS principle therefore allows gas components in a gas mixture to be measured selectively.

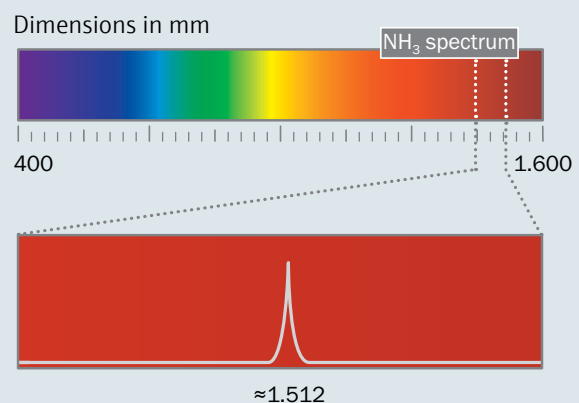

## Product versions

The GM700 system offers the following versions for optimum adaptation to the measurement task:

**GM700 – version with measuring probe**

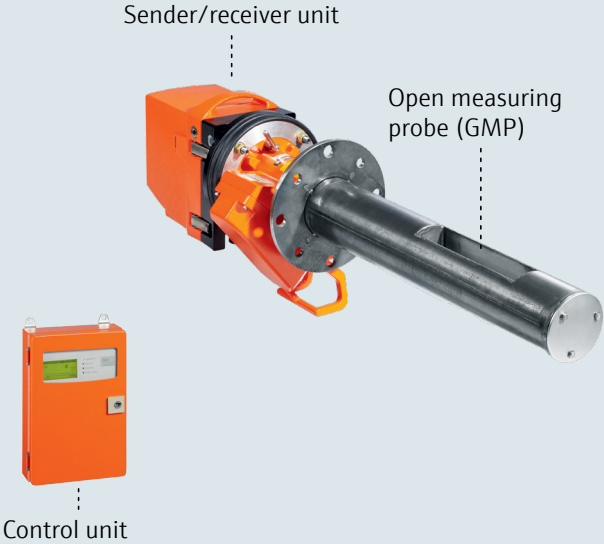

Sender/receiver unit

Open measuring probe (GMP)

Control unit

**Device components**

- Sender/receiver unit with optical and electronic modules
- Measuring probe with purge air attachment as version with an open measuring path (GMP) or as a gas-testable measuring probe (GPP)
- Control unit for output of measured values and performing the control and monitoring function

**Optional components**

- Purge air unit
- Weather protection hoods
- Flange with pipe for mounting

**Advantages**

- Access to the duct from one side and easy mounting
- Integrated zero-point path
- Application adjustment irrespective of duct dimensions and plant conditions
- Drift and calibration-free

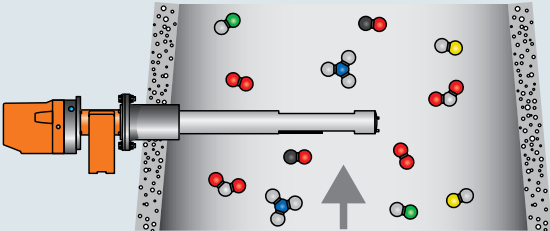

**GM700 – cross-duct version**

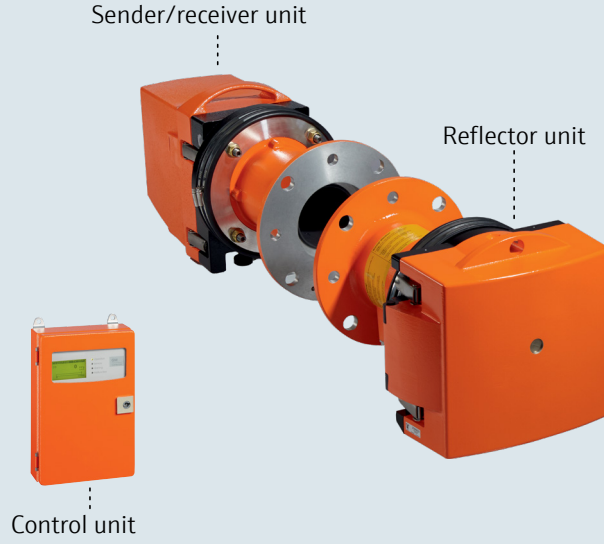

Sender/receiver unit

Reflector unit

Control unit

**Device components**

- Sender/receiver unit with optical and electronic modules
- Reflector unit with triple reflector and purge air attachment
- Control unit for output of measured values and performing the control and monitoring function

**Optional components**

- Purge air unit
- Weather protection hoods
- Flange with pipe for mounting
- Zero-point comparison path

**Advantages**

- Representative measurement results due to measurement across the entire duct cross section
- Drift and calibration-free
- Particularly low maintenance

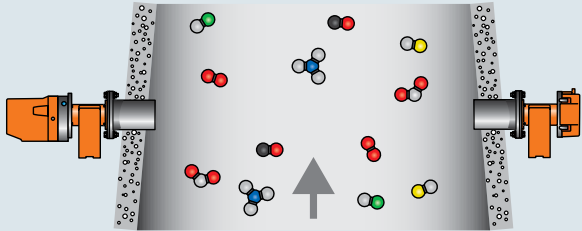

# GM700: In-situ laser gas analyzer for emission monitoring and process measurement



## Product Description

Reliability, precision and very short response times are the decisive features of the GM700 laser gas analyzer. Based on the TDLS (tunable diode laser spectroscopy) principle, the GM700 measures different gas

components, such as  $\text{NH}_3$ , HF, HCl, CO or  $\text{H}_2\text{O}$ , by specific light absorption. In-situ measurement is ideal for the rapid determination of gas concentrations in process control and emission monitoring.

## At a glance

- High selectivity due to high spectral resolution
- Short response times
- No calibration required
- No moving parts: minimal wear and tear
- No gas sampling or conditioning required

## Your benefits

- In-situ measurement directly in the process for accurate measured values
- Probe and cross-duct versions to match the requirements of your measuring task perfectly
- High reliability during operation
- Can also be used in harsh ambient conditions
- Detects quick and short-term process fluctuations

## Fields of application

- Ammonia slip measurement in DeNO<sub>x</sub> plants
- Emission monitoring of hydrogen fluoride in aluminum smelters
- Ammonia measurement in automotive exhaust gases
- Ammonia measurement in composting or waste incineration plants
- HCl measurement in incineration plants
- HF measurement in the ceramics industry
- Scrubber control in the semiconductor industry
- CO measurement for combustion control applications



## More Information online

For more information, enter the link or scan the QR code to get direct access to technical data, operating instructions, software, application examples, and much more.

[www.endress.com/gm700](http://www.endress.com/gm700)



# Technical Data

The precise device specifications and product performance data may vary and are dependent on the respective application and customer specifications.

## GM700 general

Measured values	NH <sub>3</sub> , HF, HCl, CO, H <sub>2</sub> O
Performance-tested measurands	HF
Measurement principles	Diode laser spectroscopy (TDLS)
Length of measuring path	
Cross-duct version	0.5 m ... 6 m, depending on application
Open measuring probe (GMP)	0.25 mm ... 1.5 m, depending on application
Gas-testable measuring probe (GPP)	0.227 m ... 0.977 m, depending on application
Measuring ranges	
NH <sub>3</sub> (up to 20 Vol.-% H <sub>2</sub> O):	0 ... 25 ppm / 0 ... 4,000 ppm
NH <sub>3</sub> (up to 40 Vol.-% H <sub>2</sub> O):	0 ... 25 ppm / 0 ... 100 ppm
HF:	0 ... 3 ppm / 0 ... 2,000 ppm <sup>1)</sup>
HCl:	0 ... 7.5 ppm / 0 ... 3,000 ppm <sup>1)</sup>
CO:	0 ... 100 ppm / 0 ... 30,000 ppm
H <sub>2</sub> O:	0 ... 25 Vol.-% / 0 ... 100 Vol.-%
	Measuring ranges refer to 1 m measuring path Measuring ranges depend on application and device version
Dual measuring ranges	
NH <sub>3</sub> / H <sub>2</sub> O:	0 ... 25 ppm / 0 ... 4,000 ppm (NH <sub>3</sub> ) 0 ... 20 Vol.-% / 0 ... 20 Vol.-% (H <sub>2</sub> O)
NH <sub>3</sub> / H <sub>2</sub> O high humidity:	0 ... 25 ppm / 0 ... 100 ppm (NH <sub>3</sub> ) 0 ... 40 Vol.-% / 0 ... 40 Vol.-% (H <sub>2</sub> O high humidity)
HCl / H <sub>2</sub> O:	0 ... 10 ppm / 0 ... 3,000 ppm (HCl) 0 ... 50 Vol.-% / 0 ... 100 Vol.-% (H <sub>2</sub> O)
	Measuring ranges refer to 1 m measuring path Measuring ranges depend on application and device version
Certified measuring ranges	
HF:	0 ... 5 mg/m <sup>3</sup> / 0 ... 25 mg/m <sup>3</sup>
	Suitability-tested in the cross-duct type
Response time (t <sub>90</sub> )	
Standard:	1 s ... 360 s, adjustable, preset to 4 s
HF measurement:	1 s ... 180 s, adjustable, preset to 4 s
Accuracy	
Zero point:	≤ ± 2 %, relative to measuring range end value
Sensitivity:	≤ ± 2 %, within the maintenance interval (6 months), relative to measuring range full scale
Process temperature	-40 °C ... +430 °C, depending from device version

<sup>1)</sup> The specified data are based on 1 m measuring path, 25 °C sample gas temperature and 1 bar sample gas pressure in N<sub>2</sub>

Ambient temperature	- 40 °C ... +50 °C, max. temperature change 50 °C, temperature change max. ±10 °C/h
Storage temperature	-40 °C ... +55 °C
Ambient humidity	≤ 95 %, relative humidity; non-condensing
Conformities	27 <sup>th</sup> BImSchV 30 <sup>th</sup> BImSchV TA-Luft (Prevention of Air Pollution) EN 15267 EN 14181
Electrical safety	CE
Mounting	Mounting flange, DN125, PN6 Mounting flange, ANSI, 5"
Test functions	Automatic check cycle for zero and span point (only for NH <sub>3</sub> , HCl and CO)
Options	SCU control unit (for non-hazardous areas only)

### Open measuring probe (GMP)

Description	Measuring probe in open design with integrated purge air control system
Measuring distance	See dimensional drawings
Accuracy	
Pressure sensor:	1 %
Temperature sensor:	1 %
Process temperature	≤ +250 °C From 200 °C with heated purge air
Dust load	≤ 3 g/m <sup>3</sup> , based on a 1 m measuring distance, depending on application
Electrical safety	CE
Enclosure rating	IP 65
Dimensions (W x H x D)	Dimensions may vary. For details, see the dimensional drawings.
Weight	See dimensional drawings
Material in contact with media	Stainless steel 1.4571, stainless steel 1.4539
Power supply	
Voltage	24 V DC Supply via sender/receiver unit
Auxiliary gas connections	
Purge air	Hose nozzle 40 mm
Integrated components	Flow monitor for purge air monitoring PT1000 temperature sensor Pressure sensor

**Gas-testable measuring probe (GPP)**

Description	Measuring probe with gas permeable filter element for adjustment with test gas
Measuring distance	See dimensional drawings
Accuracy	
Pressure sensor:	1 %
Temperature sensor:	1 %
Process temperature	
HCl:	+130 °C ... +430 °C
NH <sub>3</sub>	+300 °C ... +430 °C
Dust load	≤ 30 g/m <sup>3</sup>
Electrical safety	CE
Enclosure rating	IP 65
Dimensions (W x H x D)	Dimensions may vary. For details, see the dimensional drawings.
Weight	See dimensional drawings
Material in contact with media	Stainless steel 1.4571, stainless steel 1.4539, ceramics, PTFE
Power supply	
Voltage:	115 V AC, ± 10 % 230 V AC, ± 10 %
Frequency	50 Hz / 60 Hz
Power consumption	≤ 150 VA
Auxiliary gas connections	
Test gas	Clamp connection 1/4"
Integrated components	PT1000 temperature sensor Pressure sensor

**Sender/receiver unit**

Description	Analyzer unit of the measuring device
Electrical safety	CE
Enclosure rating	IP 65
Dimensions (W x H x D)	239 mm x 316 mm x 338 mm (for details see dimensional drawings)
Weight	13 kg
Power supply	
Voltage:	24 V DC, supply via sender/receiver unit
Current	≥ 1,5 A
Power consumption	≤ 36 W

**Reflector unit** (cross-duct version)

Description	Reflector unit with hollow triple reflector.
Measuring distance	0.25 m ... 6 m
Process temperature	≤ +250 °C From 200 °C with heated purge air
Dust load	≤ 3 g/m <sup>3</sup>
Electrical safety	CE
Enclosure rating	IP 65
Dimensions (W x H x D)	291 mm x 280 mm x 161 mm (for details see dimensional drawings)
Weight	8.5 kg

**AWE control unit**

Description	The control unit serves as the human machine interface and is responsible for data processing and output as well as control and monitoring functions.
Electrical safety	CE
Enclosure rating	IP 65
Analog outputs	3 outputs: 0/4 ... 20 mA, 500 Ω, electrically isolated
Analog inputs	2 inputs: 0 ... 20 mA, 100 Ω For gas temperature and gas pressure
Digital outputs	3 relay contacts: 48 V AC, 1 A, 60 W / 48 V DC, 1 A, 30 W Preset for failure, maintenance and functional control
Digital inputs	3 inputs: 24 V
Serial	✓
Type of field bus integration	RS-232
Function	Proprietary service interface
PROFIBUS DP	✓
Remark	Only for HF
CAN bus	✓
Function	<b>Internal system bus</b>
Display	LC display Status LEDs: "Operation", "Service", "Warning" and "Malfunction"
Input	Arrow keys, functional keys
Operation	Menu-driven operation via LC-display and membrane keyboard
Model	Steel sheet enclosure
Dimensions (W x H x D)	200 mm x 346 mm x 97.5 mm (for details see dimensional drawings)
Weight	4.7 kg

Power supply	
Voltage	115 V AC, $\pm$ 10% 230 V AC, $\pm$ 10%
Frequency	50 Hz / 60 Hz
Power consumption	$\leq$ 50 VA

### Connection unit

Description	For extending the internal CAN bus connection with a cable provided by the customer
Electrical safety	CE
Enclosure rating	IP 66
Dimensions (W x H x D)	175 mm x 110.5 mm x 175 mm (for details see dimensional drawings)
Weight	3 kg
Power supply	
Voltage	115 V AC, $\pm$ 10% 230 V AC, $\pm$ 10%
Frequency	50 Hz / 60 Hz
Power consumption	$\leq$ 50 VA
Integrated components	On-board 24 V power supply for the sender/receiver unit

### Purge air attachment

Description	Flange fixture for connections for purge air hose, temperature and pressure sensor
Electrical safety	CE
Dimensions (W x H x D)	309 mm x 364 mm x 242 mm (for details see dimensional drawings)
Weight	9.6 kg
Auxiliary gas connections	
Purge air	Hose nozzle 40 mm
Integrated components	Flow monitor for purge air monitoring Pressure sensor (only for sender/receiver unit) Temperature sensor (only for sender/receiver unit)

**SLV4-2 purge air unit, 2BH1300, 3-ph**

Description	Unit to provide dust-free air for flushing of optical surfaces
Gas flow rate	38 m <sup>3</sup> /h ... 63 m <sup>3</sup> /h At 30 hPa counter pressure, depending on low pressure inside the filter
Ambient temperature	-40 °C ... +55 °C
Electrical safety	CE
Enclosure rating	IP 54
Dimensions (W x H x D)	550 mm x 550 mm x 258 mm (for details see dimensional drawings)
Weight	18 kg
Power supply	
Three-phase current	Δ: 200 ... 240 V AC, 50 Hz, 2,6 A, 400 VA Y: 345 ... 415 V AC, 50 Hz, 1,5 A, 400 VA Δ: 200 ... 275 V AC, 60 Hz, 2,6 A, 500 VA Y: 380 ... 480 V AC, 60 Hz, 1,5 A, 500 VA Δ: 270 ... 330 V AC, 50 Hz, 2,0 A, 400 VA Y: 465 ... 570 V AC, 50 Hz, 1,16 A, 400 VA Δ: 290 ... 360 V AC, 60 Hz, 2,1 A, 500 VA Y: 500 ... 600 V AC, 60 Hz, 1,26 A, 500 VA Δ: 230 V AC, 50 Hz, 2,7 A, 370 VA Δ: 115 V AC, 60 Hz, 3,0 A, 450 VA Δ: 220 ... 270 V AC, 50 Hz, 2,5 A, 400 VA Y: 380 ... 465 V AC, 50 Hz, 1,45 A, 400 VA Δ: 240 ... 290 V AC, 60 Hz, 2,6 A, 500 VA Y: 415 ... 500 V AC, 60 Hz, 1,55 A, 500 VA
Auxiliary gas connections	
Purge air	40 mm
Test functions	Pressure switch (switching point -35 hPa)
Integrated components	2-step air filter, type Europiclone, dust capacity 200 g

# Order Information

Our regional sales organization will be glad to advise you on which device configuration is best for you.

## Dimensional drawings

GM700 sender/receiver unit (dimensions in mm)

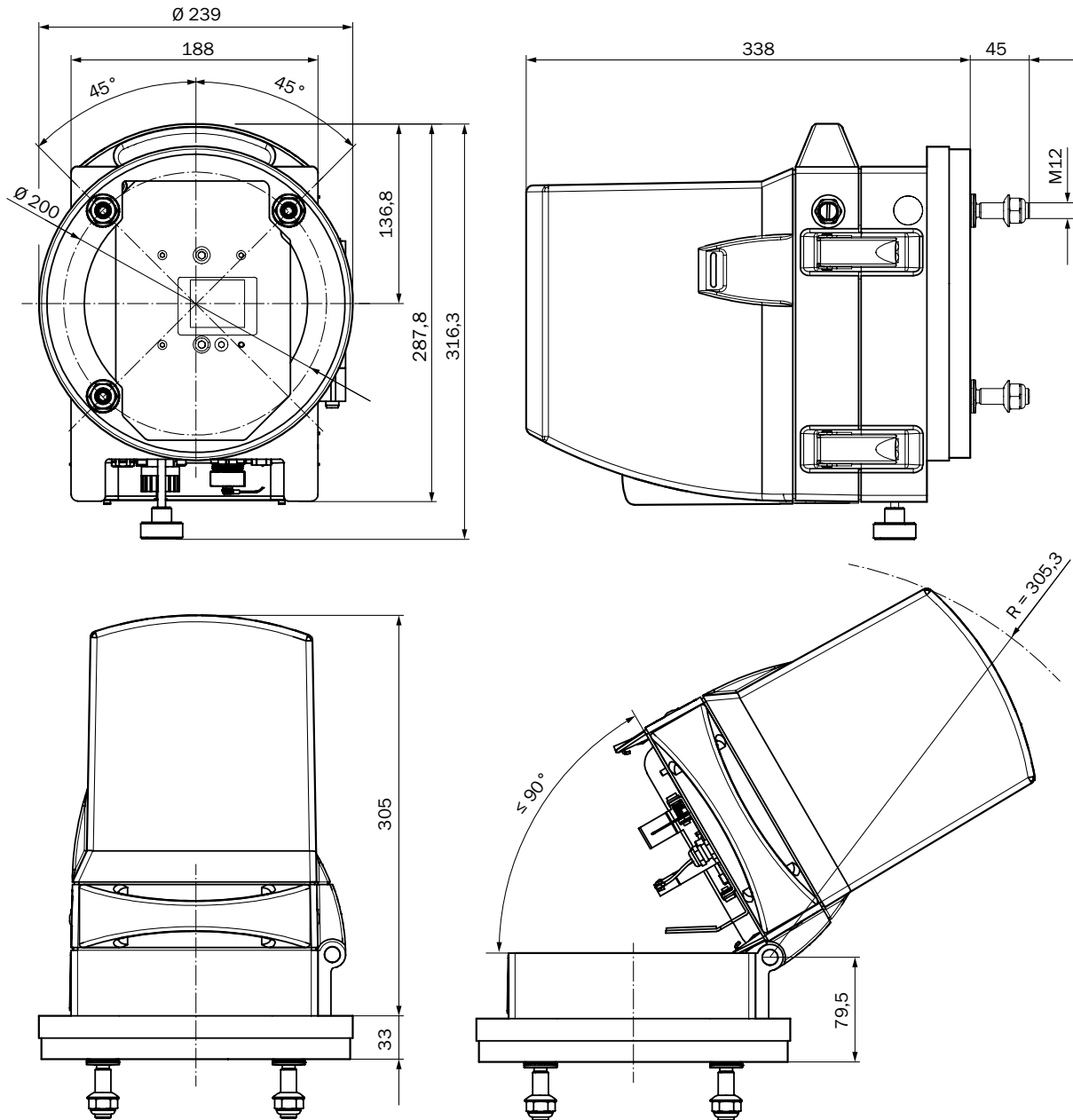

## GM700 reflector unit (dimensions in mm)

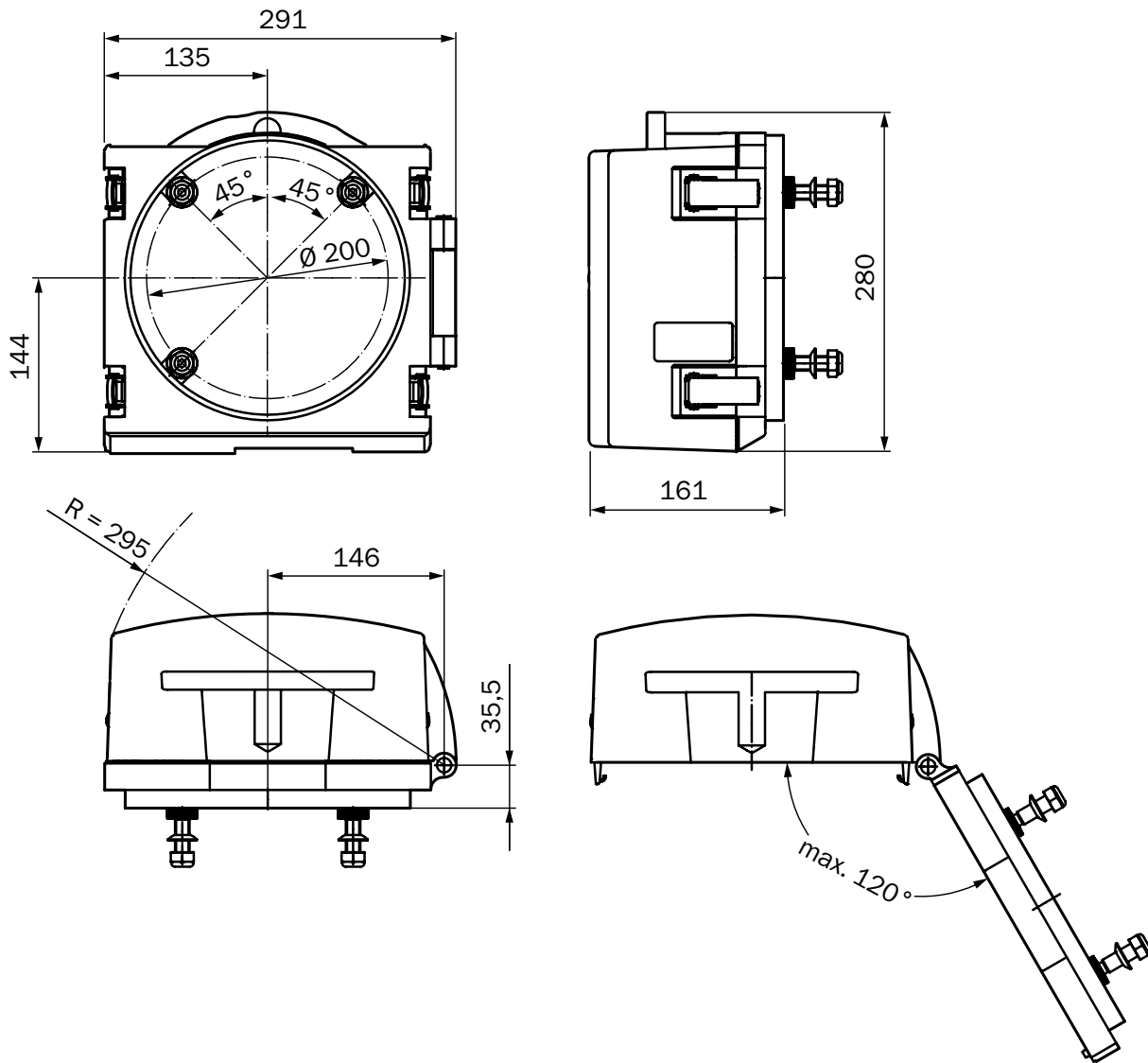

## Control unit (dimensions in mm)

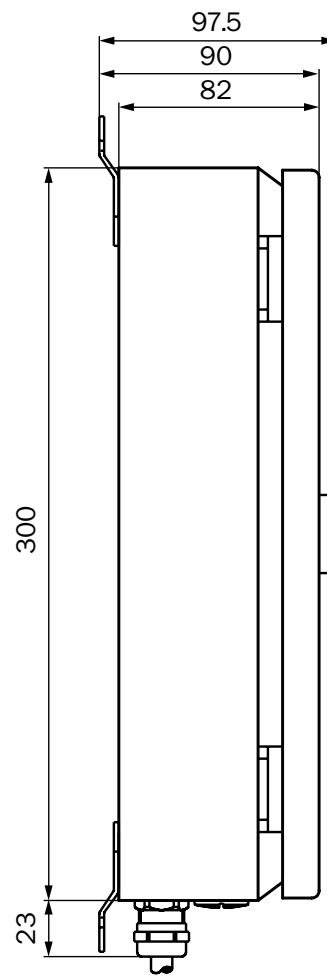
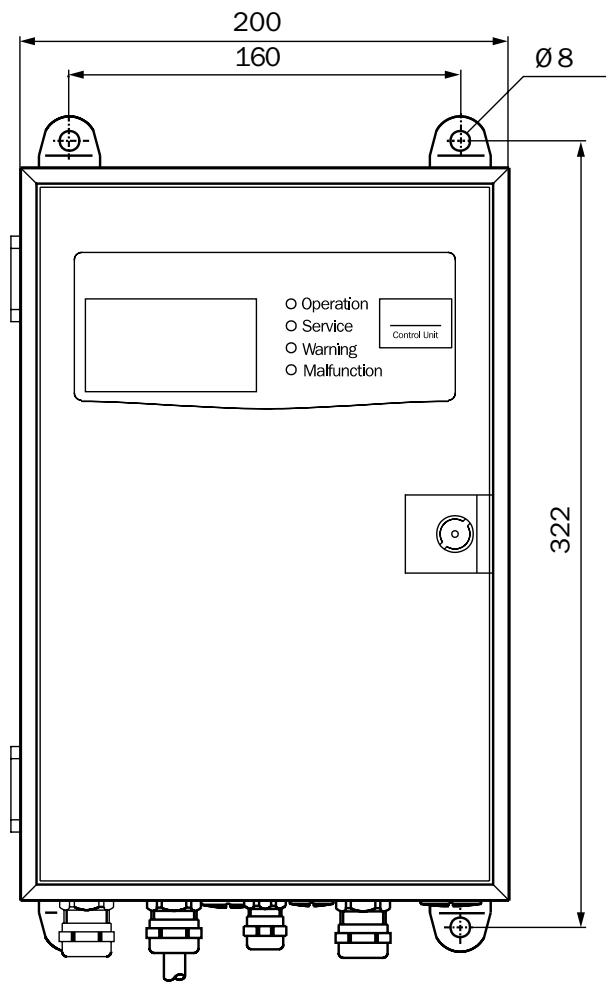

### Open measuring probe (GMP) (dimensions in mm)

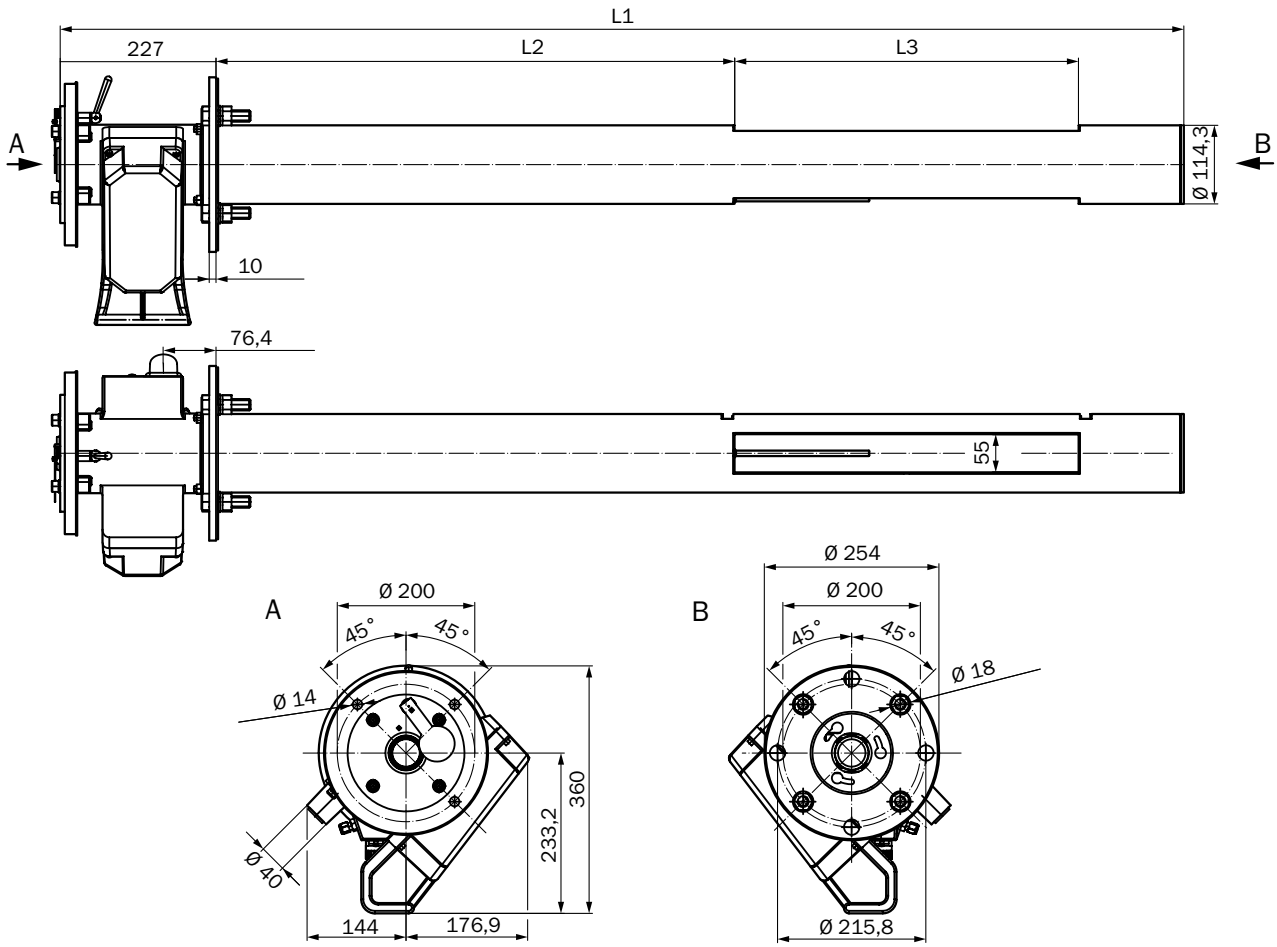

#### GMP measuring probes

Probe length, nominal	L1	Measuring gap L3 (active measuring path)						Weight
		250	500	750	1,000	1,250	1,500	
900	935	296	---	---	---	---	---	21
1,500	1,644	1,005	755	505	255	---	---	24
2,000	2,128	1,489	1,239	989	739	489	239	30

All dimensions in mm, weight in kg  
Application specific lengths on request

### Gas-testable measuring probe (GPP) (dimensions in mm)

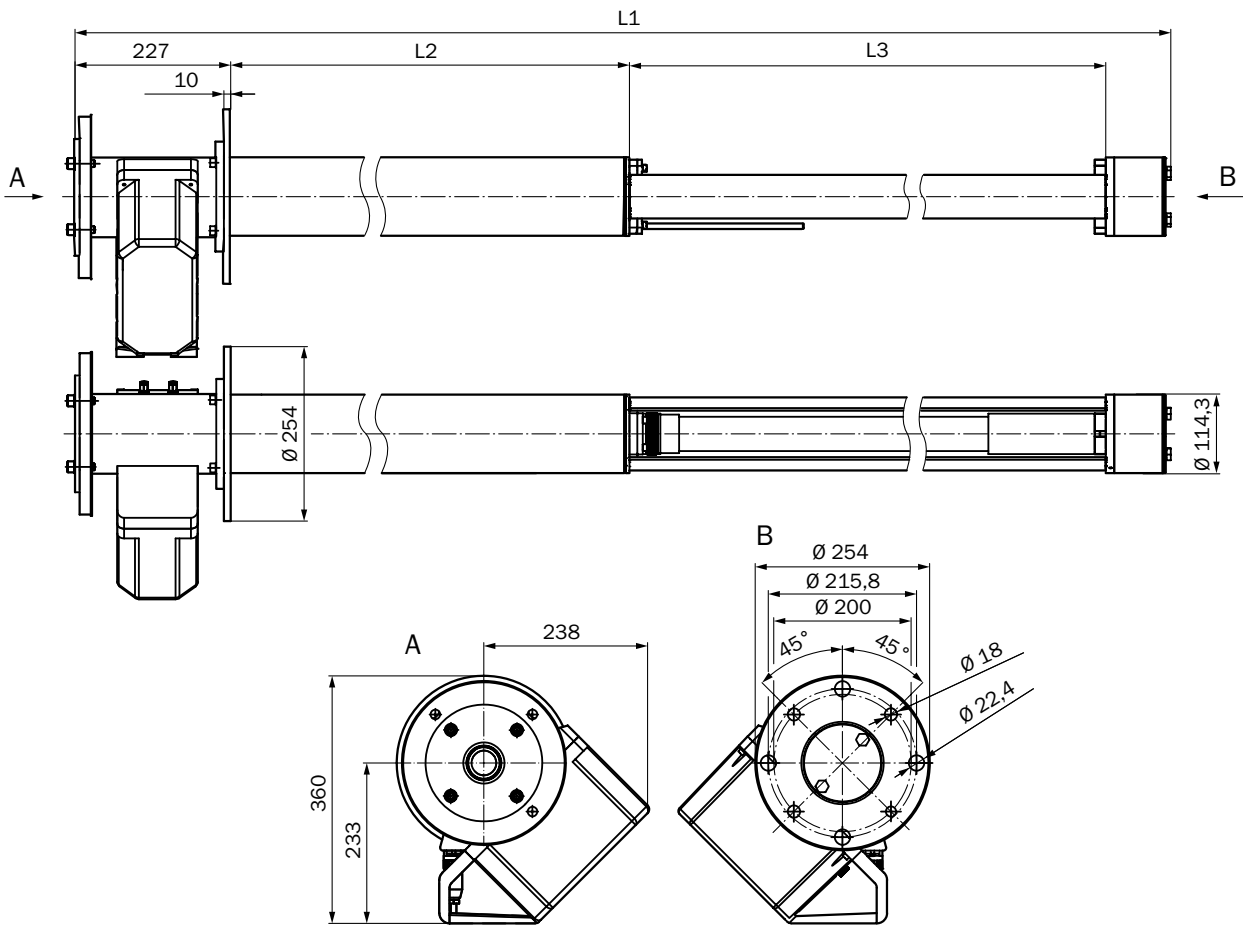

#### Gas-testable measuring probe (GPP)

Probe length, nominal	Measuring gap L3 (active measuring path)					Weight
	L1	227	477	727	977	
9,00	914	353	103	---	---	27
1,500	1,624	1,063	813	563	313	35
2,000	2,108	1,547	1,297	1,047	797	42

All dimensions in mm  
Application specific lengths on request

GM700 connection unit (dimensions in mm)

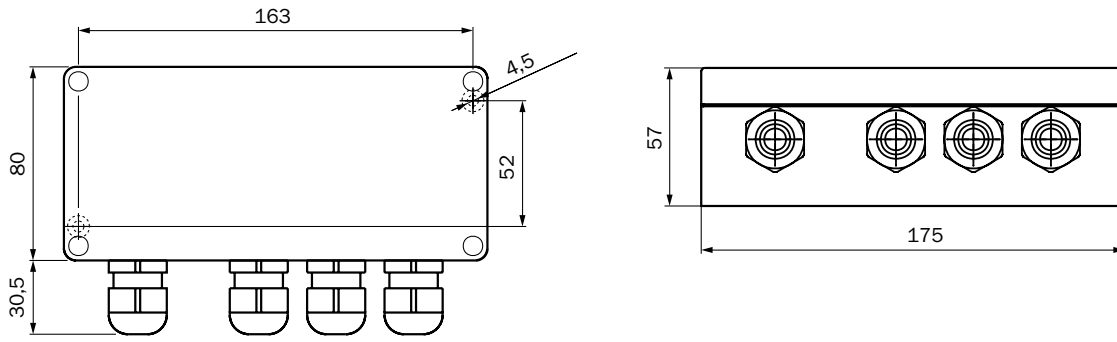

Purge air attachment (dimensions in mm)

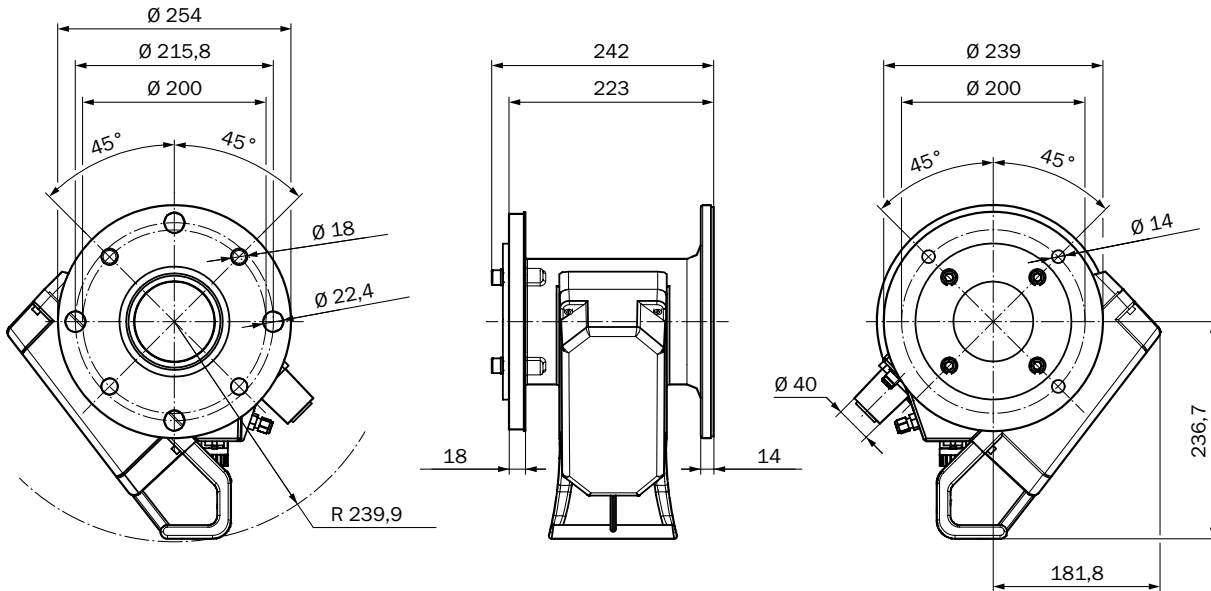

## SLV4-2 purge air unit, 2BH1300 (dimensions in mm)

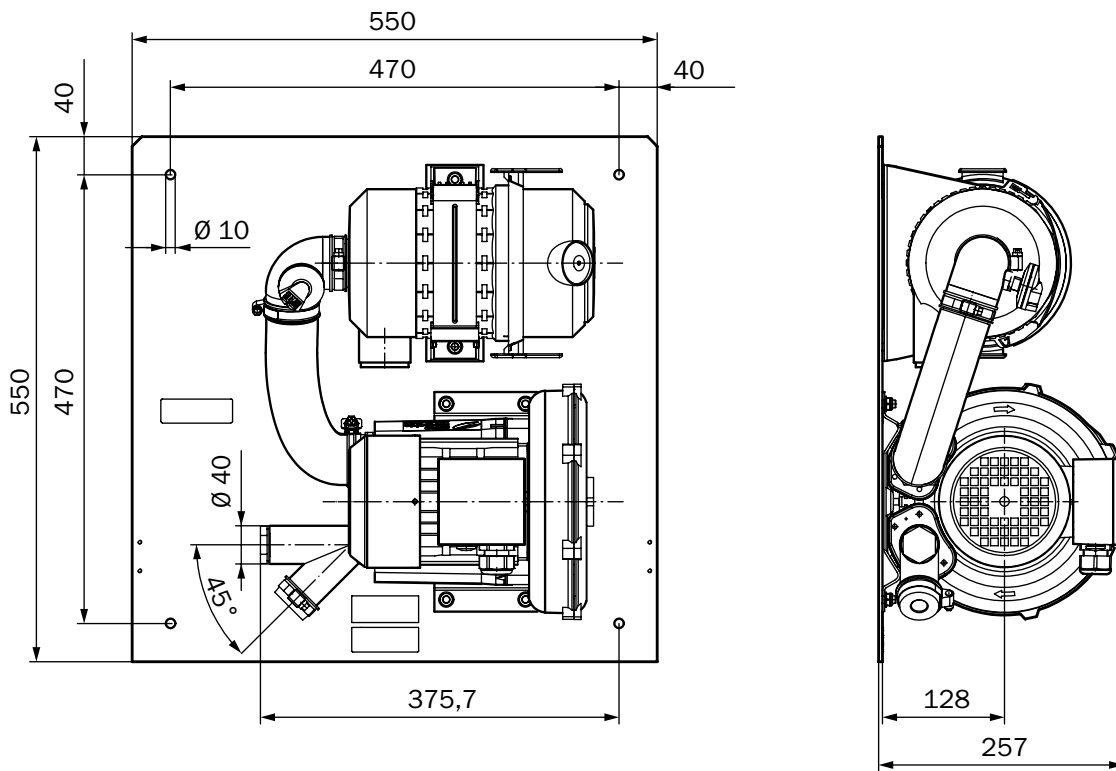

# Accessories

## Flanges

### Welded flange

Description	Hole circle diameter	Thread size	Part no.
Blind flange, with cover, reflector side, inner diameter 125 mm, nominal length 240 mm, structural steel 1.0037	—	—	2018373
Blind flange, stainless steel 1.4571	200 mm	M16	2018374
Flange with tube, inner diameter 70,2 mm, length 240 mm, structural steel 1.0037	—	—	2045800
Flange with tube, inner diameter 125 mm, length 500 mm, structural steel 1.0254	—	—	2017785
Flange with tube, inner diameter 70,2 mm, nominal length 240 mm, stainless steel 1.4571	200 mm	—	2066239
Flange with tube, inner diameter 125 mm, length 240 mm, structural steel 1.0254	—	—	2016807
Flange with tube for combined pT probe, with cover, seal, inner diameter 70 mm, nominal length 240 mm, structural steel 1.0037	100 mm	—	2034380
Flange with tube, inner diameter 125 mm, length 500 mm, stainless steel 1.4571	—	—	2017786
Flange with tube, inner diameter 125 mm, length 240 mm, stainless steel 1.4571	—	—	2016808
Flange with tube, inner diameter 125 mm, length 1000 mm, structural steel 1.0037	—	—	2027032

## Device protection (mechanical)

### Protective housing and protective pipes

Description	Part no.
Weather hood cover for analyzers or reflector	2044519

## Terminal and alignment brackets

### Alignment brackets

Description	Part no.
Optical alignment tool cross duct to align SR unit and reflector	2034121



[www.addresses.endress.com](http://www.addresses.endress.com)

---

IN01368C/90/EN/03.26-00  
8029583 / EN / V4-2