

Brief Operating Instructions

Micropilot FMR50

Level radar

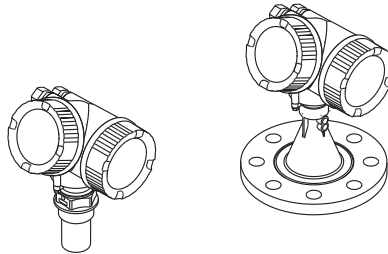

These Instructions are Brief Operating Instructions; they do not replace the Operating Instructions included in the scope of supply.

For detailed information, refer to the Operating Instructions and other documentation on the CD-ROM provided or visit "www.endress.com/deviceviewer".





Table of contents

1	Important document information	3
1.1	Document conventions	3
2	Basic safety instructions	6
2.1	Requirements for the personnel	6
2.2	Designated use	6
2.3	Workplace safety	7
2.4	Operational safety	7
2.5	Product safety	7
3	Product description	8
3.1	Product design	8
4	Incoming acceptance and product identification	10
4.1	Incoming acceptance	10
4.2	Product identification	12
5	Storage, Transport	13
5.1	Storage conditions	13
5.2	Transport product to the measuring point	13
6	Installation	14
6.1	Installation conditions	14
6.2	Measuring conditions	20
6.3	Installation in vessel (free space)	22
6.4	Installation in stilling well	27
6.5	Installation in bypass	28
6.6	Vessels with heat insulation	29
6.7	Turning the transmitter housing	29
6.8	Turning the display module	30
6.9	Post-installation check	30
7	Electrical connection	32
7.1	Connection conditions	32
7.2	Connecting the measuring device	38
7.3	Post-connection check	41
8	Integration into a PROFIBUS network	41
8.1	Overview of the device database files (GSD)	41
8.2	Set device address	41
9	Commissioning	43
9.1	Display and operating module	43
9.2	Operating menu	45
9.3	Unlock the device	46
9.4	Setting the operating language	46
9.5	Configuration of a level measurement	47
9.6	User-specific applications	49







1 Important document information

1.1 Document conventions





1.1.1 Safety symbols

Symbol	Meaning
 <small>A0011189-EN</small>	DANGER! This symbol alerts you to a dangerous situation. Failure to avoid this situation will result in serious or fatal injury.
 <small>A0011190-EN</small>	WARNING! This symbol alerts you to a dangerous situation. Failure to avoid this situation can result in serious or fatal injury.
 <small>A0011191-EN</small>	CAUTION! This symbol alerts you to a dangerous situation. Failure to avoid this situation can result in minor or medium injury.
 <small>A0011192-EN</small>	NOTICE! This symbol contains information on procedures and other facts which do not result in personal injury.





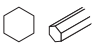

1.1.2 Electrical symbols

Symbol	Meaning
 <small>A0011197</small>	Direct current A terminal to which DC voltage is applied or through which direct current flows.
 <small>A0011198</small>	Alternating current A terminal to which alternating voltage is applied or through which alternating current flows.
 <small>A0017381</small>	Direct current and alternating current <ul style="list-style-type: none"> ▪ A terminal to which alternating voltage or DC voltage is applied. ▪ A terminal through which alternating current or direct current flows.
 <small>A0011200</small>	Ground connection A grounded terminal which, as far as the operator is concerned, is grounded via a grounding system.
 <small>A0011199</small>	Protective ground connection A terminal which must be connected to ground prior to establishing any other connections.
 <small>A0011201</small>	Equipotential connection A connection that has to be connected to the plant grounding system: This may be a potential equalization line or a star grounding system depending on national or company codes of practice.

1.1.3 Tool symbols



 A0011219	 A0011220	 A0013442	 A0011221	 A0011222
Cross-head screwdriver	Flat blade screwdriver	Torx screwdriver	Allen key	Hexagon wrench

1.1.4 Symbols for certain types of information



Symbol	Meaning
 A0011182	Allowed Indicates procedures, processes or actions that are allowed.
 A0011183	Preferred Indicates procedures, processes or actions that are preferred.
 A0011184	Forbidden Indicates procedures, processes or actions that are forbidden.
 A0011193	Tip Indicates additional information.
 A0011194	Reference to documentation Refers to the corresponding device documentation.
 A0011195	Reference to page Refers to the corresponding page number.
 A0011196	Reference to graphic Refers to the corresponding graphic number and page number.
1., 2., 3. ...	Series of steps
✓	Result of a sequence of actions

1.1.5 Symbols in graphics

Symbol	Meaning
1, 2, 3 ...	Item numbers
1., 2., 3. ...	Series of steps
A, B, C, ...	Views
A-A, B-B, C-C, ...	Sections

Symbol	Meaning
 <small>A0011187</small>	Hazardous area Indicates a hazardous area.
 <small>A0011188</small>	Safe area (non-hazardous area) Indicates a non-hazardous location.

1.1.6 Symbols at the device

Symbol	Meaning
	Safety instructions Observe the safety instructions contained in the associated Operating Instructions.
	Temperature resistance of the connection cables Specifies the minimum value of the temperature resistance of the connection cables.

2 Basic safety instructions

2.1 Requirements for the personnel

The personnel must fulfill the following requirements for its tasks:

- ▶ Trained, qualified specialists must have a relevant qualification for this specific function and task
- ▶ Are authorized by the plant owner/operator
- ▶ Are familiar with federal/national regulations
- ▶ Before beginning work, the specialist staff must have read and understood the instructions in the Operating Instructions and supplementary documentation as well as in the certificates (depending on the application)
- ▶ Following instructions and basic conditions

2.2 Designated use

Application and measured materials

The measuring device described in these Operating Instructions is intended for the continuous, contactless level measurement of liquids, pastes and sludge. The device can also be freely mounted outside closed metal vessels because of its operating frequency of about 26 GHz, a maximum radiated pulsed power of 5.7 mW and an average power output of 0.015 mW (for the version with advanced dynamics: maximum pulse power: 23.3 mW; average power: 0.076 mW). Operation is completely harmless to humans and animals.

Observing the limit values specified in the "Technical data" and listed in the Operating Instructions and supplementary documentation, the measuring device may be used for the following measurements only:

- ▶ Measured process variables: level, distance, signal strength
- ▶ Calculated process variables: Volume or mass in arbitrarily shaped vessels; flow through measuring weirs or flumes (calculated from the level by the linearization functionality)

To ensure that the measuring device remains in proper condition for the operation time:

- ▶ Use the measuring device only for measured materials against which the process-wetted materials are adequately resistant.
- ▶ Observe the limit values in "Technical data".

Incorrect use

The manufacturer is not liable for damage caused by improper or non-designated use.

Verification for borderline cases:

- ▶ For special measured materials and cleaning agents, Endress+Hauser is glad to provide assistance in verifying the corrosion resistance of wetted materials, but does not accept any warranty or liability.

Residual risk

The electronics housing and its built-in components such as display module, main electronics module and I/O electronics module may heat to 80 °C (176 °F) during

operation through heat transfer from the process as well as power dissipation within the electronics. During operation the sensor may assume a temperature near the temperature of the measured material.

Danger of burns due to heated surfaces!

- ▶ For high process temperatures: Install protection against contact in order to prevent burns.

2.3 Workplace safety

For work on and with the device:

- ▶ Wear the required personal protective equipment according to federal/national regulations.

2.4 Operational safety

Risk of injury.

- ▶ Operate the device in proper technical condition and fail-safe condition only.
- ▶ The operator is responsible for interference-free operation of the device.

Conversions to the device

Unauthorized modifications to the device are not permitted and can lead to unforeseeable dangers.

- ▶ If, despite this, modifications are required, consult with the manufacturer.

Repair

To ensure continued operational safety and reliability,

- ▶ Carry out repairs on the device only if they are expressly permitted.
- ▶ Observe federal/national regulations pertaining to repair of an electrical device.
- ▶ Use original spare parts and accessories from the manufacturer only.

Hazardous area

To eliminate a danger for persons or for the facility when the device is used in the hazardous area (e.g. explosion protection, pressure vessel safety):

- ▶ Based on the nameplate, check whether the ordered device is permitted for the intended use in the hazardous area.
- ▶ Observe the specifications in the separate supplementary documentation that is an integral part of these Instructions.

2.5 Product safety

This measuring device is designed in accordance with good engineering practice to meet state-of-the-art safety requirements, has been tested, and left the factory in a condition in which they are safe to operate.

It meets general safety standards and legal requirements. It also complies with the EC directives listed in the device-specific EC Declaration of Conformity. Endress+Hauser confirms this by affixing the CE mark to the device.

3 Product description

3.1 Product design

3.1.1 Micropilot FMR50

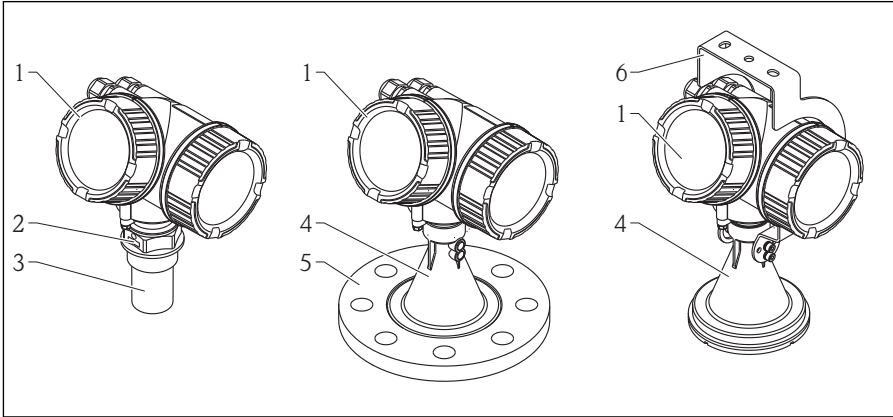

A0016784

 1 Design of the Micropilot FMR50 (26 GHz)

- 1 Electronics housing
- 2 Process connection (Thread)
- 3 Horn antenna 40 mm (1-1/2 in), PVDF encapsulated
- 4 Horn antenna 80mm/100 mm (3in/4 in), PP cladded
- 5 Slip-on flange
- 6 Mounting bracket

3.1.2 Electronics housing

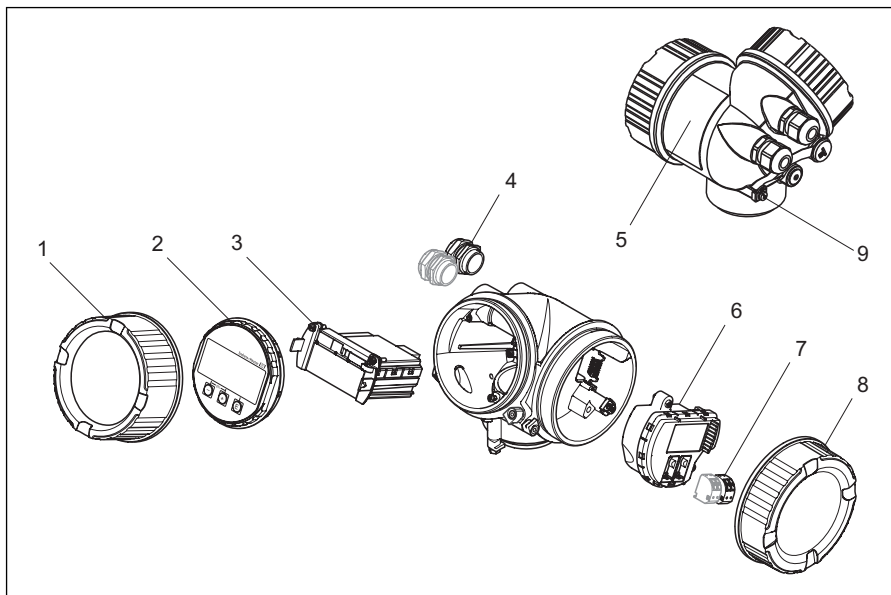

A0012422

2 Design of the electronics housing

- 1 Electronics compartment cover
- 2 Display module
- 3 Main electronics module
- 4 Cable glands (1 or 2, depending on instrument version)
- 5 Nameplate
- 6 I/O electronics module
- 7 Terminals (pluggable spring terminals)
- 8 Connection compartment cover
- 9 Grounding terminal

4 Incoming acceptance and product identification

4.1 Incoming acceptance

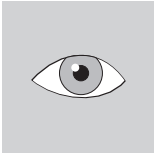

A0013696



1 = 2

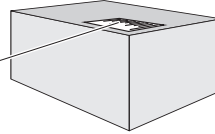

A0016870

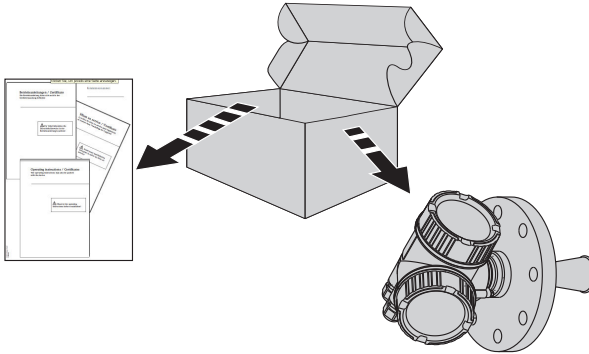

A0016871

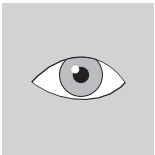

A0013696

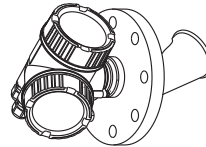
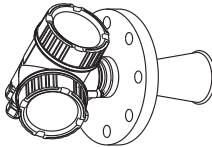

A0016872

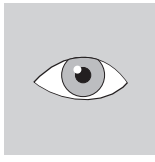

A0013696

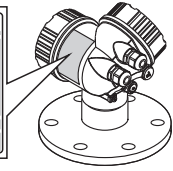
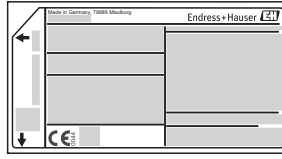
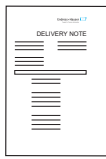

A0014038

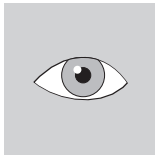

A0013696



A0014037



If one of the conditions does not comply, contact your Endress+Hauser distributor.

4.2 Product identification

The following options are available for identification of the measuring device:

- Nameplate specifications
- Extended order code with breakdown of the device features on the delivery note
- Enter serial numbers from nameplates in *W@M Device Viewer* (www.endress.com/deviceviewer): All information about the measuring device is displayed.

For an overview of the scope of the Technical Documentation provided, refer to the following: enter serial numbers from nameplates in *W@M Device Viewer* (www.endress.com/deviceviewer)

4.2.1 Nameplate

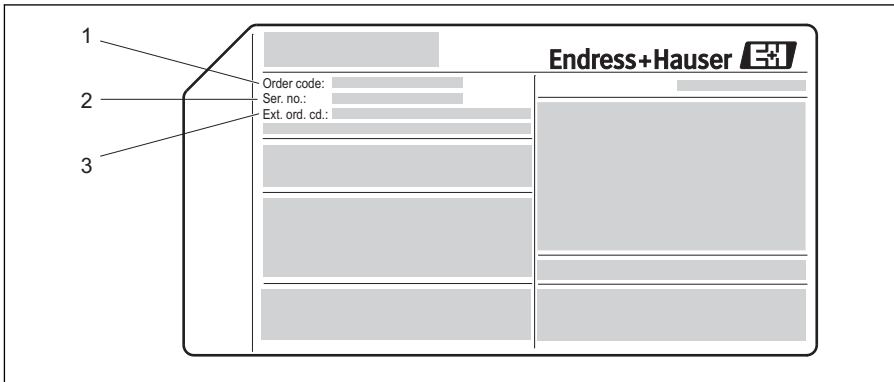

A0014103

 3 Example of a nameplate

- 1 Order code
- 2 Serial number (Ser. no.)
- 3 Extended order code (Ext. ord. cd.)

 For detailed information about interpreting the nameplate specifications, refer to the Operating Instructions for the device on the CD-ROM provided.

 Only 33 digits of the extended order code can be indicated on the nameplate. If the extended order code exceeds 33 digits, the rest will not be shown. However, the complete extended order code can be viewed in the operating menu of the device (Diagnostics → Device info → Extended order code 1/2/3).

5 Storage, Transport

5.1 Storage conditions

- Permitted storage temperature: -40 to $+80$ °C (-40 to $+176$ °F)
- Use the original packaging.

5.2 Transport product to the measuring point

NOTICE

Housing or antenna horn may be damaged or break away.

Risk of injury!

- ▶ Transport the measuring device to the measuring point in its original packaging or at the process connection.
- ▶ Do not fasten lifting devices (hoisting slings, lifting eyes etc.) at the housing or the antenna horn but at the process connection. Take into account the mass center of the device in order to avoid unintended tilting.
- ▶ Comply with the safety instructions, transport conditions for devices over 18kg (39.6lbs).

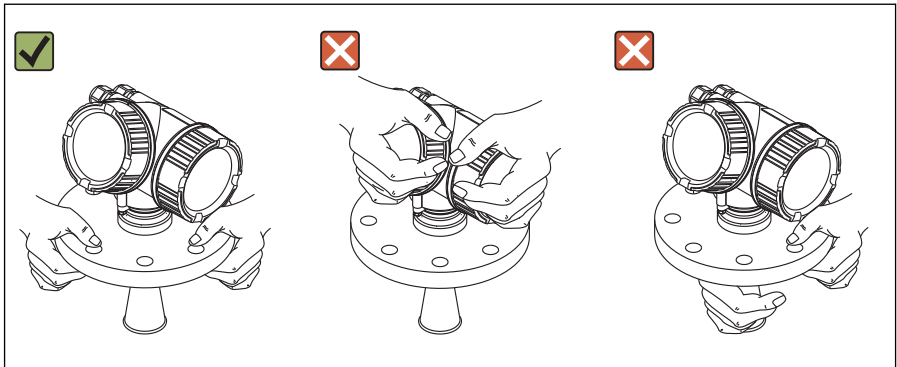

A0016875

6 Installation

6.1 Installation conditions

6.1.1 Mounting position

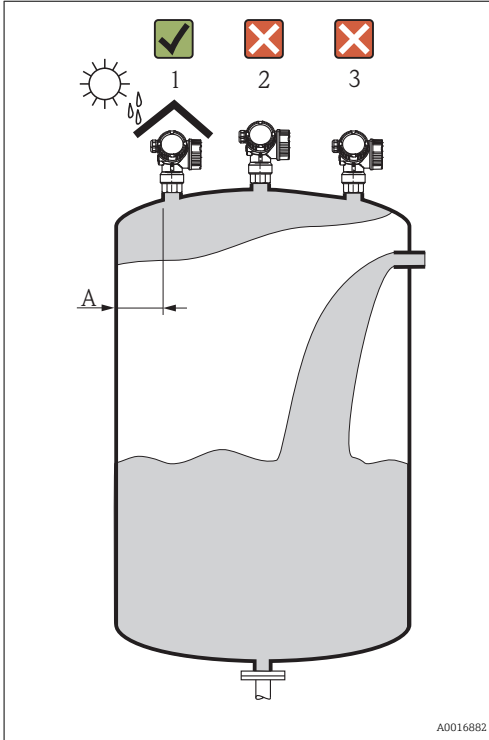

- Recommended distance **A** from wall to outer edge of nozzle: ~ 1/6 of tank diameter. Nevertheless the device should not be installed closer than 15 cm (5.91 in) to the tank wall.
- Not in the center (2), as interference can cause signal loss.
- Not above the fill stream (3).
- It is recommended to use a weather protection cover (1) in order to protect the device from direct sun or rain.

6.1.2 Vessel installations

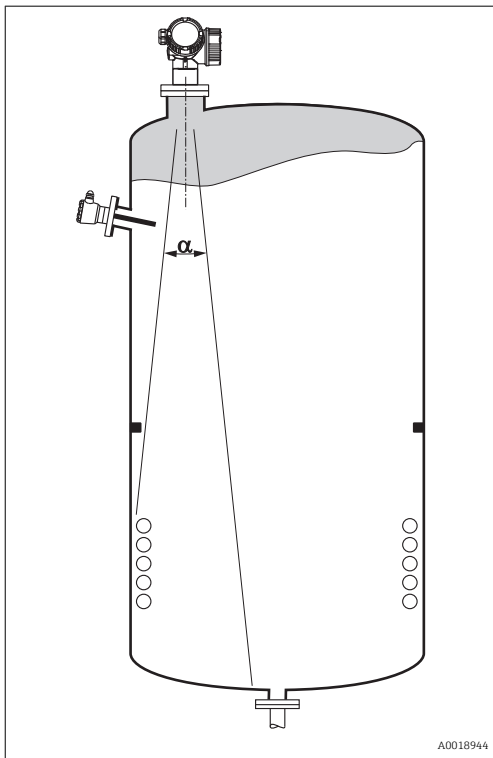

Avoid any installations (limit switches, temperature sensors, braces, vacuum rings, heating coils, baffles etc.) inside the signal beam. Take into account the beam angle (\rightarrow  19).

6.1.3 Reduction of interference echoes

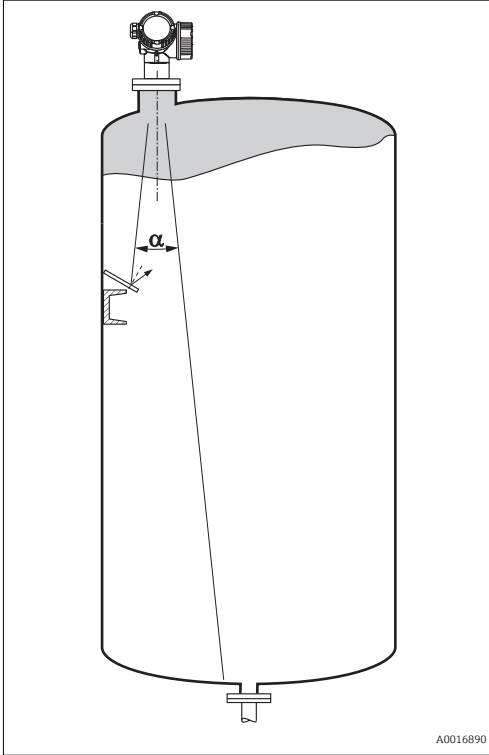

Metallic screens mounted at a slope spread the radar signal and can, therefore, reduce interference echoes.



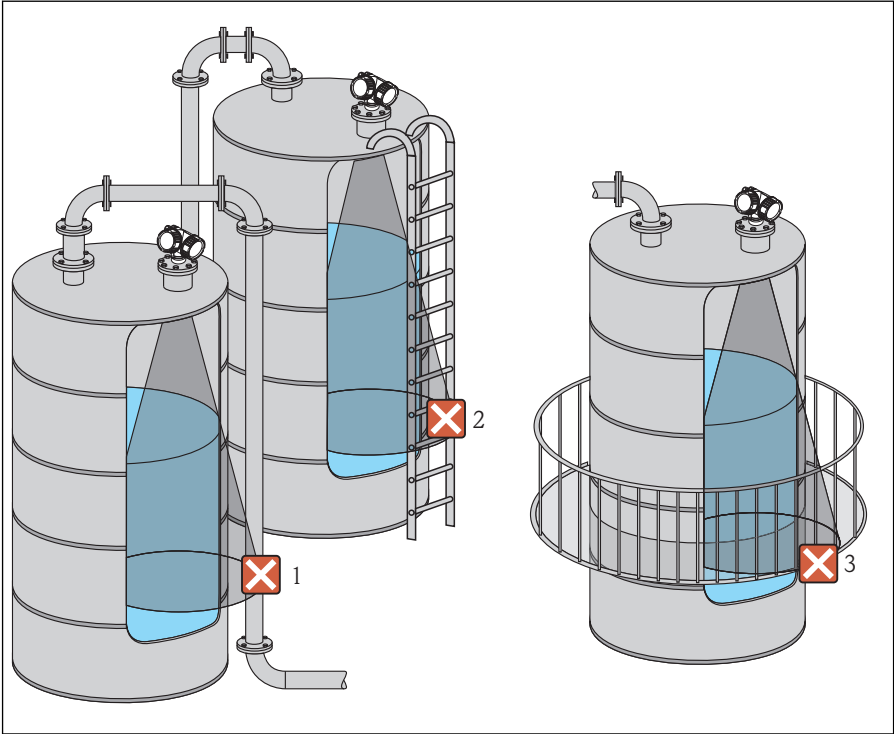

6.1.4 Measurement in a plastic vessel

If the outer wall of the vessel is made of a non-conductive material (e.g. GRP), microwaves can also be reflected off interfering installations outside the signal beam (e.g. metallic pipes (1), ladders (2), grates (3), ...). Therefore, there should be no such interfering installations in the signal beam. Please contact Endress+Hauser for further information.



A0017123

6.1.5 Optimization options

- Antenna size
The bigger the antenna, the smaller the beam angle α and the fewer interference echoes (→  19).
- Mapping
The measurement can be optimized by means of electronic suppression of interference echoes.
- Antenna alignment
Take into account the marker on the flange or threaded connection (→  22) (→  24) .
- Stilling well
A stilling well can be applied to avoid interferences (→  27).
- Metallic screens mounted at a slope
They spread the radar signals and can, therefore, reduce interference echoes.

6.1.6 Beam angle

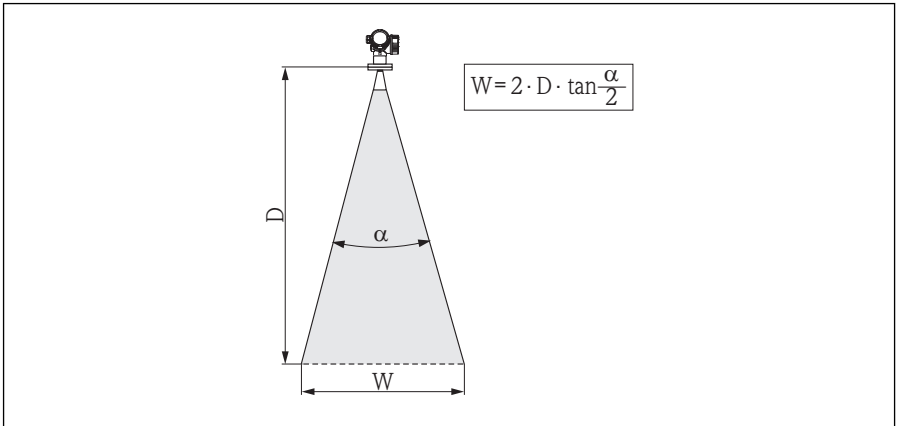

A0016891

4 Relationship between beam angle α , distance D and beamwidth diameter W

The beam angle is defined as the angle α where the energy density of the radar waves reaches half the value of the maximum energy density (3-dB-width). Microwaves are also emitted outside the signal beam and can be reflected off interfering installations.

Beam diameter W as a function of beam angle α and measuring distance D :

FMR50			
Antenna size	40 mm (1-1/2 in)	80 mm (3 in)	100 mm (4 in)
Beam angle α	23°	10°	8°
Measuring distance (D)	Beamwidth diameter W		
3 m (9.8 ft)	1.22 m (4 ft)	0.53 m (1.7 ft)	0.42 m (1.4 ft)
6 m (20 ft)	2.44 m (8 ft)	1.05 m (3.4 ft)	0.84 m (2.8 ft)
9 m (30 ft)	3.66 m (12 ft)	1.58 m (5.2 ft)	1.26 m (4.1 ft)
12 m (39 ft)	4.88 m (16 ft)	2.1 m (6.9 ft)	1.68 m (5.5 ft)
15 m (49 ft)	6.1 m (20 ft)	2.63 m (8.6 ft)	2.10 m (6.9 ft)
20 m (66 ft)	8.14 m (27 ft)	3.50 m (11 ft)	2.80 m (9.2 ft)
25 m (82 ft)	10.17 m (33 ft)	4.37 m (14 ft)	3.50 m (11 ft)
30 m (98 ft)	-	5.25 m (17 ft)	4.20 m (14 ft)
35 m (115 ft)	-	6.12 m (20 ft)	4.89 m (16 ft)
40 m (131 ft)	-	7.00 m (23 ft)	5.59 m (18 ft)

6.2 Measuring conditions

- In case of **boiling surfaces**, **bubbling** or tendency for **foaming** use FMR53 or FMR54. Depending on its consistence, foam can either absorb microwaves or reflect them off the foam surface. Measurement is possible under certain conditions. For FMR50, FMR51 and FMR52, the additional option "Advanced dynamics" is recommended in these cases (feature 540: "Application Package", option EM).
- In case of heavy **steam development** or **condensate**, the maximum measuring range of FMR50, FMR51 and FMR52 may decrease depending on density, temperature and composition of the steam → use FMR53 or FMR54.
- For the measurement of absorbing gases such as **ammonia NH₃** or some **fluorocarbons**¹⁾, please use Levelflex or Micropilot FMR54 in a stilling well.
- The measuring range begins, where the beam hits the tank bottom. Particularly with dish bottoms or conical outlets the level cannot be detected below this point.
- For stilling well applications, the zero should be positioned at the end of the tube, as the electromagnetic waves do not propagate completely outside the tube. It must be taken into account that the accuracy may be reduced in the area **C**. In order to guarantee the required accuracy in these cases, it is recommended to position the zero-point at a distance **C** above the end of the tube (see figure).
- In case of media with a low dielectric constant ($\epsilon_r = 1.5$ to 4)²⁾ the tank bottom can be visible through the medium at low levels (low height **C**). Reduced accuracy has to be expected in this range. If this is not acceptable, we recommend positioning the zero point at a distance **C** (see figure) above the tank bottom in these applications.
- In principle it is possible to measure up to the tip of the antenna with FMR51, FMR53 and FMR54. However, due to considerations regarding corrosion and build-up, the end of the measuring range should not be chosen any closer than **A** (see figure) to the tip of the antenna.
- When using FMR54 with planar antenna, especially for media with low dielectric constants, the end of the measuring range should not be closer than 1 m (3.28 ft) to the flange.
- The smallest possible measuring range **B** depends on the antenna version (see figure).
- The tank height should be at least **H** (see table).

1) Affected compounds are e.g. R134a, R227, Dymel 152a.

2) Dielectric constants of important media commonly used in the industry are summarized in the document SD106F, which can be downloaded from the Endress+Hauser web page (www.endress.com).

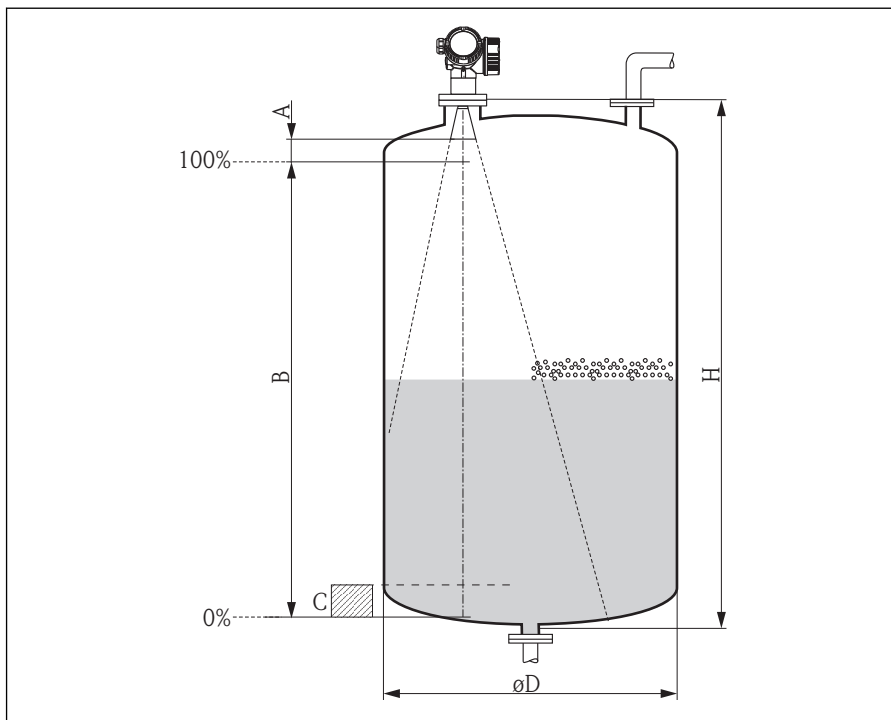

A0018872

Device	A [mm (in)]	B [m (ft)]	C [mm (in)]	H [m (ft)]
FMR50	150 (5.91)	> 0.2 (0.7)	50 to 250 (1.97 to 9.84)	> 0.3 (1.0)

6.3 Installation in vessel (free space)

6.3.1 Horn antenna encapsulated (FMR50)

Alignment

- Align the antenna vertically to the product surface.
- A marking at the threaded connection enables alignment of the antenna. This marking must be aligned towards the tank wall as well as possible.

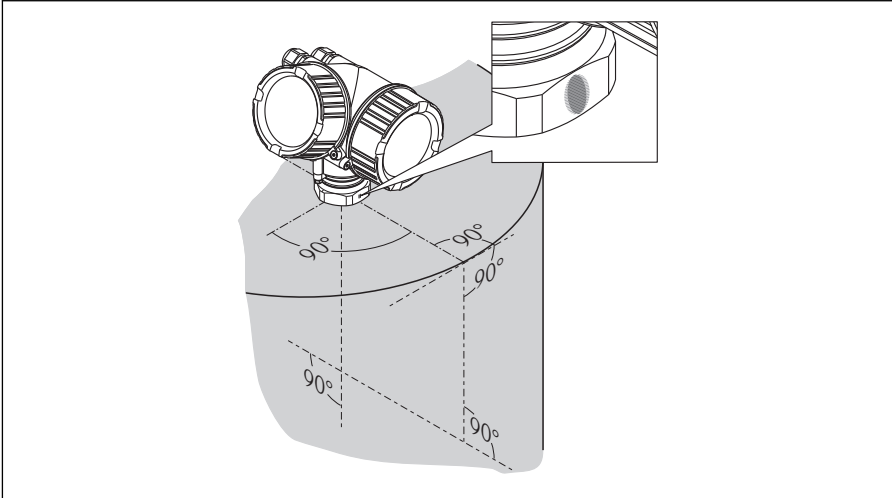

A0019434

Nozzle mounting

For optimum measurement, the tip of the antenna should extend below the nozzle. Nozzle heights up to 500 mm (19.7 in) can be accepted if this should not be possible due to mechanical reasons.

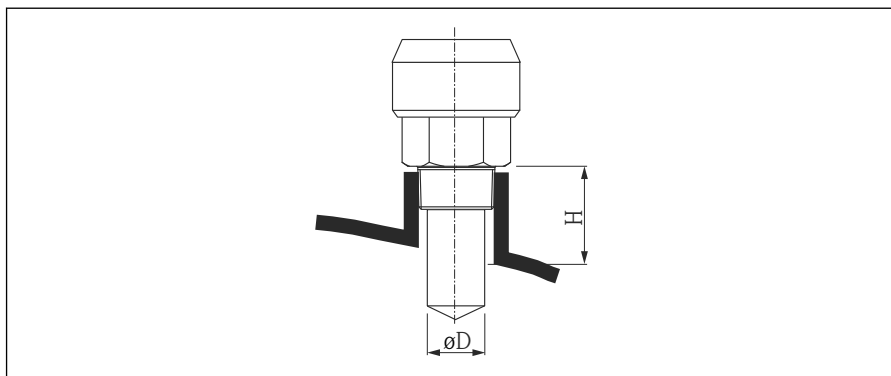

A0016806

- 5 Nozzle height and diameter for horn antenna, encapsulated (FMR50)

Antenna size	40 mm (1½ in)
D	39 mm (1.54 in)
H	< 60 mm (2.36 in)

-  Please contact Endress+Hauser for applications with higher nozzle.

Threaded connection

- Tighten with the hexagonal nut only.
- Tool : Hexagonal wrench 50 mm
- Maximum permissible torque: 35 Nm (26 lbf ft)

6.3.2 Horn antenna with slip-on flange (FMR50)

Alignment

i When using the Micropilot with a slip-on flange in explosion-hazardous areas, strictly observe all specifications in the relevant Safety Instructions (XA).

- Align the antenna vertically to the product surface.
Optionally, a variable flange seal, which is available as an accessory, can be used for alignment (see Technical Information BA01048F, chapter "Accessories").
- A marking at the feedthrough enables alignment of the antenna. This marking must be aligned towards the tank wall as well as possible.

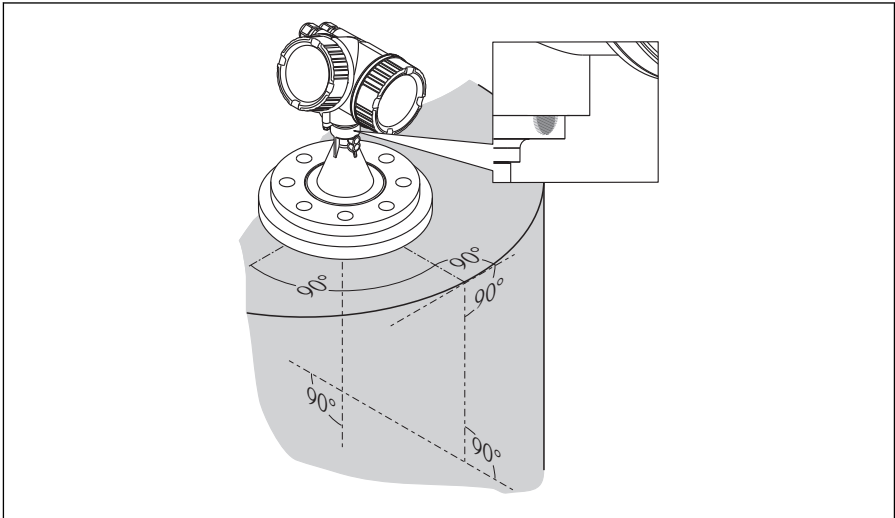

A0019439

Nozzle mounting

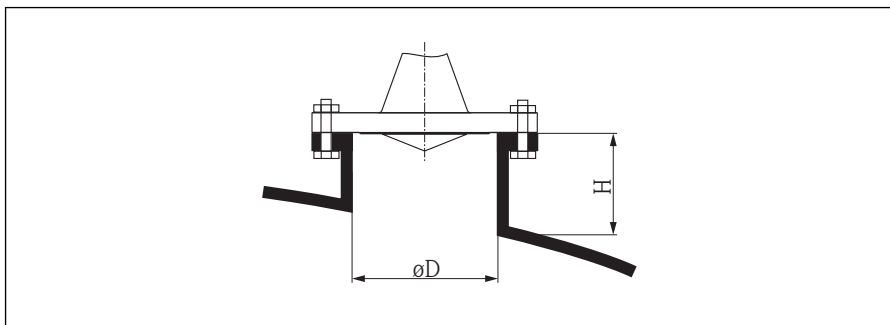

A0016868

6 Nozzle height and diameter for horn antenna with slip-on flange (FMR50/FMR56)

Antenna size	80 mm (3 in)			100 mm (4 in)	
D	80 mm (3.15 in)	100 mm (3.94 in)	150 mm (5.91 in)	100 mm (3.94 in)	150 mm (5.91 in)
H	< 500 mm (19.7 in)	< 500 mm (19.7 in)	< 500 mm (19.7 in)	< 500 mm (19.7 in)	< 500 mm (19.7 in)

6.3.3 Horn antenna with mounting bracket (FMR50)

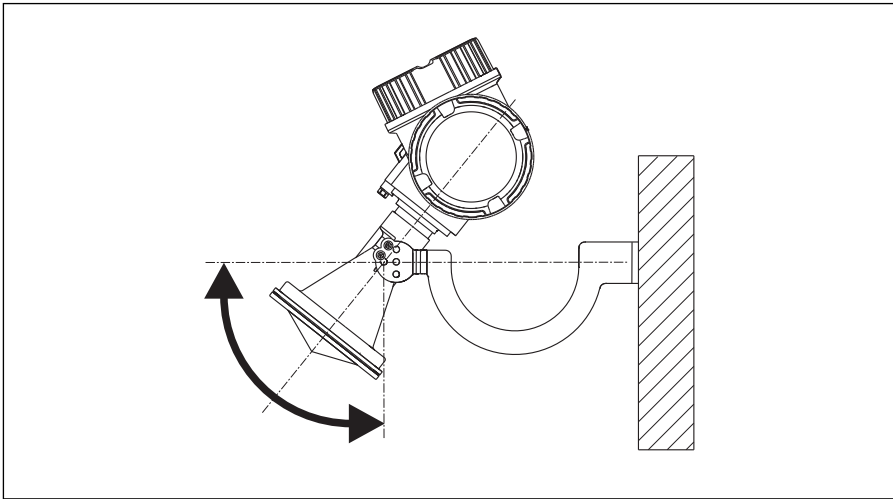

A0016865

 7 Installation of the horn antenna with mounting bracket (FMR50/FMR56)

Align the antenna vertically to the product surface using the mounting bracket.

NOTICE

The mounting bracket has no conductive connection to the transmitter housing.

Danger of electrostatic charge

- ▶ Connect the mounting bracket to the local potential equalization system.

6.4 Installation in stilling well

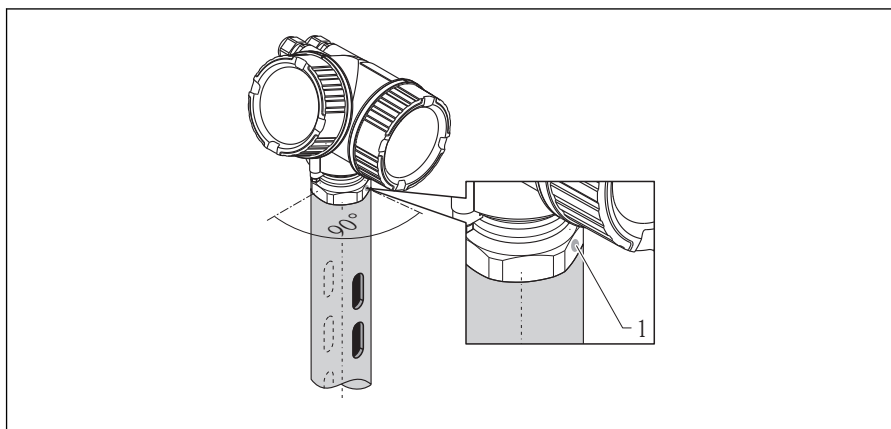

A001694.1

8 Installation in stilling well

1 Marking for antenna alignment

- For horn antenna: Align the marking towards the slots of the stilling well.
- Measurements can be performed through an open full bore ball valve without any problems.
- After mounting, the housing can be turned 350° in order to simplify access to the display and the terminal compartment (→ 29).

6.5 Installation in bypass

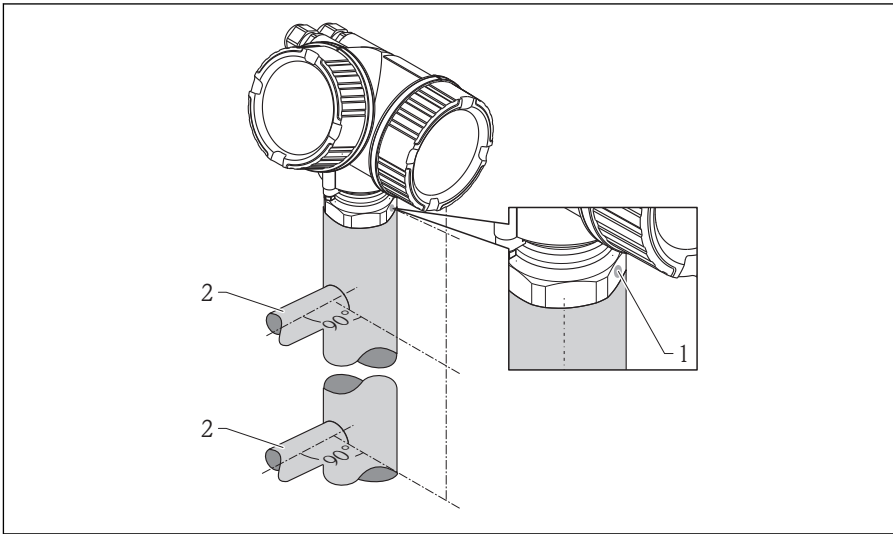

A0019446

9 Installation in bypass

- 1 Marking for antenna alignment
2 Tank connectors

- Align the marker perpendicular (90°) to the tank connectors.
- Measurements can be performed through an open full bore ball valve without any problems.
- After mounting, the housing can be turned 350° in order to simplify access to the display and the terminal compartment (→  29).

6.6 Vessels with heat insulation

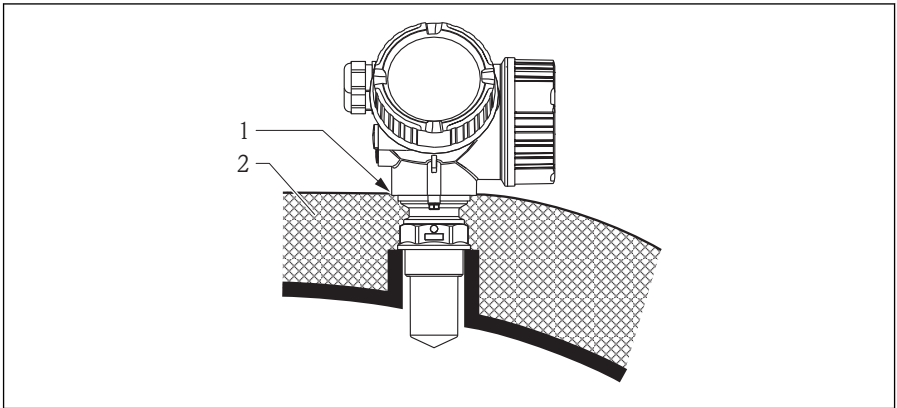

A0019141

If process temperatures are high, the device must be included in normal tank insulation to prevent the electronics heating up as a result of heat radiation or convection. The insulation may not exceed beyond the neck of the housing.

6.7 Turning the transmitter housing

To provide easier access to the connection compartment or display module, the transmitter housing can be turned:

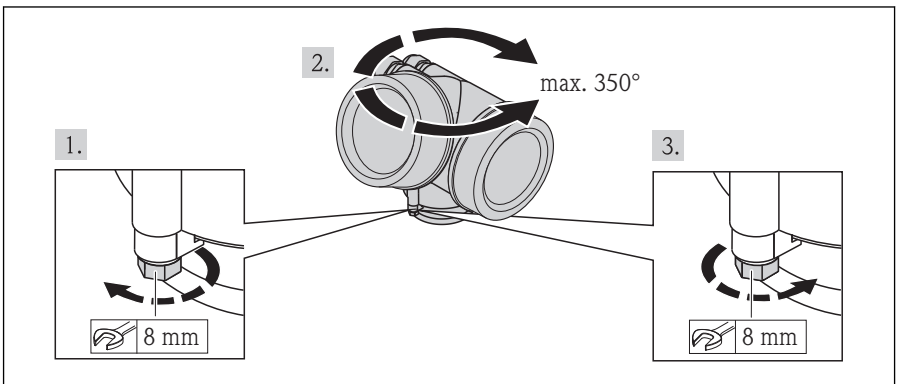

A0013713

1. Unscrew the securing screw using an open-ended wrench.
2. Rotate the housing in the desired direction.

- 3. Tighten the securing screw (1,5 Nm for plastics housing; 2,5 Nm for aluminium or stainless steel housing).

6.8 Turning the display module

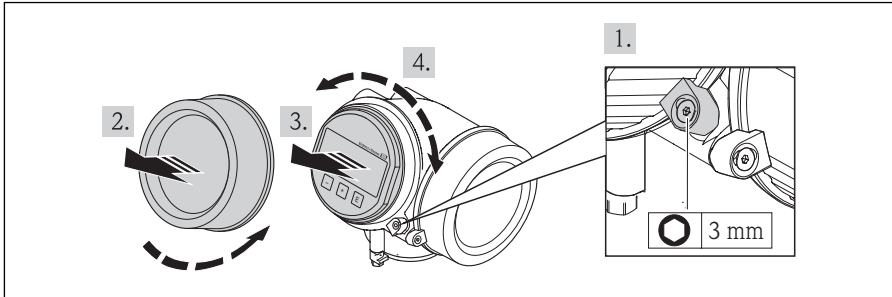

A0013905

- 1. Loosen the screw of the securing clamp of the electronics compartment cover using an Allen key and turn the clamp 90° counterclockwise.
- 2. Unscrew cover of the electronics compartment from the transmitter housing.
- 3. Pull out the display module with a gentle rotation movement.
- 4. Rotate the display module into the desired position: Max. $8 \times 45^\circ$ in each direction.
- 5. Feed the spiral cable into the gap between the housing and main electronics module and plug the display module into the electronics compartment until it engages.
- 6. Screw the cover of the electronics compartment firmly back onto the transmitter housing.
- 7. Tighten the securing clamp again using the Allen key.

6.9 Post-installation check

○	Is the device undamaged (visual inspection)?
○	Does the device conform to the measuring point specifications? For example: <ul style="list-style-type: none"> ■ Process temperature ■ Process pressure (refer to the chapter on "Material load curves" of the "Technical Information" document) ■ Ambient temperature range ■ Measuring range
○	Are the measuring point identification and labeling correct (visual inspection)?

<input type="radio"/>	Is the device adequately protected from precipitation and direct sunlight?
<input type="radio"/>	Are the securing screw and securing clamp tightened securely?

7 Electrical connection

7.1 Connection conditions

7.1.1 Cable specification

For ambient temperature $T_U \geq 60$ °C (140 °F): use cable for temperature $T_U + 20$ K.

PROFIBUS

Use a twisted, screened two-wire cable, preferably cable type A.



For further information on the cable specifications, see Operating Instructions BA00034S "Guidelines for planning and commissioning PROFIBUS DP/PA", PNO Guideline 2.092 "PROFIBUS PA User and Installation Guideline" and IEC61158-2 (MBP).

7.1.2 Terminal assignment

PROFIBUS PA / FOUNDATION Fieldbus

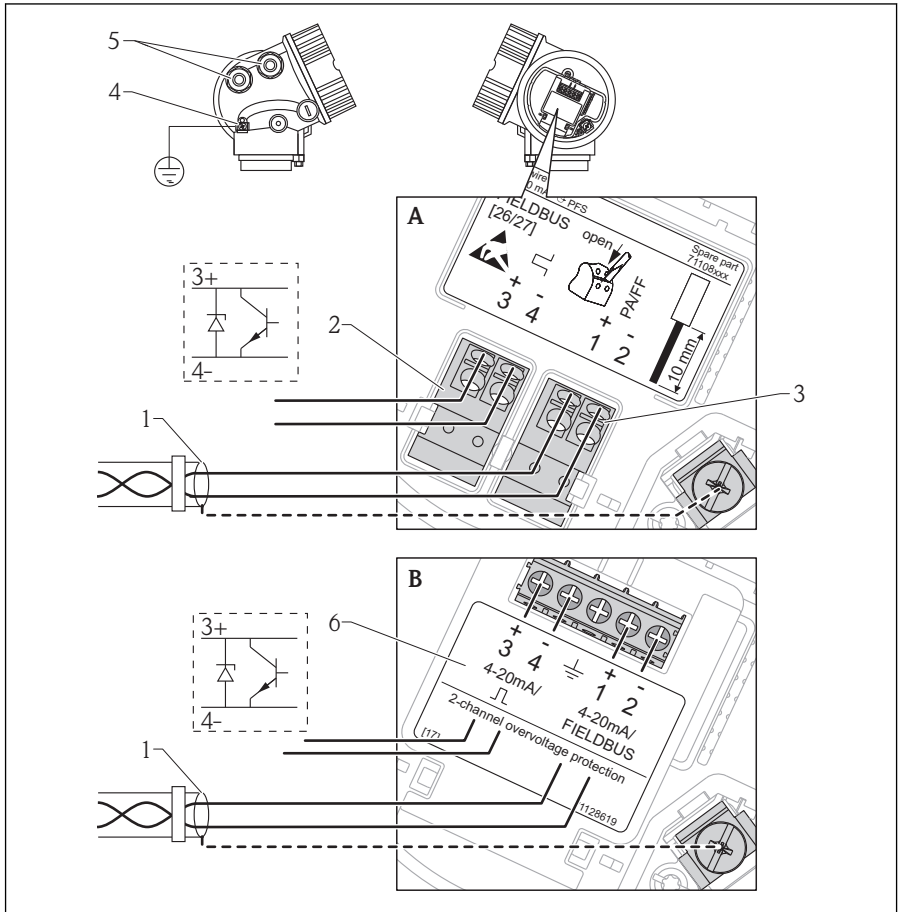

A0011341

10 Terminal assignment PROFIBUS PA / FOUNDATION Fieldbus

- A Without integrated overvoltage protection
- B With integrated overvoltage protection
- 1 Cable screen: Observe cable specifications (→ 32)
- 2 Terminals for switch output (open collector)
- 3 Terminals PROFIBUS PA / FOUNDATION Fieldbus
- 4 Terminal for potential equalization line
- 5 Cable entries
- 6 Overvoltage protection module

Connection examples for the switch output

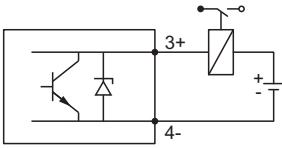

A0015909

11 Connection of a relay

Suitable relays (examples):

- Solid-state relay: Phoenix Contact OV-24DC/480AC/5 with mounting rail connector UMK-1 OM-R/AMS
- Electromechanical relay: Phoenix Contact PLC-RSC-12DC/21

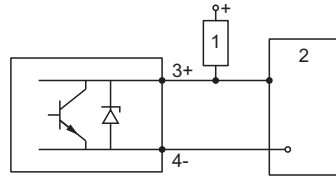

A0015910

12 Connection of a digital input

- 1 Pull-up resistor
- 2 Digital input

7.1.3 Device plug connectors

i For the versions with fieldbus plug connector (M12 or 7/8"), the signal line can be connected without opening the housing.

Pin assignment of the M12 plug connector

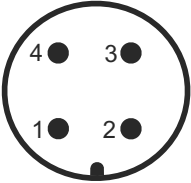
 <p style="text-align: right; margin-top: 10px;">A0011175</p>	Pin	Meaning
	1	Signal +
	2	not connected
	3	Signal -
	4	Ground

Pin assignment of the 7/8" plug connector

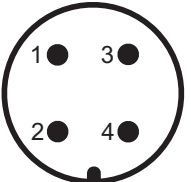
 <p style="text-align: right; margin-top: 10px;">A0011176</p>	Pin	Meaning
	1	Signal -
	2	Signal +
	3	Screen
	4	Not connected

7.1.4 Supply voltage

PROFIBUS PA, FOUNDATION Fieldbus

"Power supply; Output" ¹⁾	"Approval" ²⁾	Terminal voltage
E: 2-wire; FOUNDATION Fieldbus, switch output (in preparation) G: 2-wire; PROFIBUS PA, switch output	<ul style="list-style-type: none"> ▪ Non-Ex ▪ Ex nA ▪ Ex nA(ia) ▪ Ex ic ▪ Ex ic(ia) ▪ Ex d(ia) / XP ▪ Ex ta / DIP ▪ CSA GP 	9 to 32 V ³⁾
	<ul style="list-style-type: none"> ▪ Ex ia / IS ▪ Ex ia + Ex d(ia) / IS + XP 	9 to 30 V ³⁾

- 1) Feature 020 of the product structure
 2) Feature 010 of the product structure
 3) Input voltages up to 35 V will not spoil the device.

Polarity sensitive	No
FISCO/FNICO compliant according to IEC 60079-27	Yes

7.1.5 Overvoltage protection

If the measuring device is used for level measurement in flammable liquids which requires the use of overvoltage protection according to DIN EN 60079-14, standard for test procedures 60060-1 (10 kA, pulse 8/20 μ s), overvoltage protection has to be ensured by an integrated or external overvoltage protection module.

Integrated overvoltage protection

An integrated overvoltage protection module is available for 2-wire HART as well as PROFIBUS PA and FOUNDATION Fieldbus devices.

Product structure: Feature 610 "Accessory mounted", option NA "Overvoltage protection".

Technical data	
Resistance per channel	2 * 0.5 Ω max
Threshold DC voltage	400 to 700 V
Threshold impulse voltage	< 800 V
Capacitance at 1 MHz	< 1.5 pF
Nominal arrest impulse voltage ($^{8/20}$ μ s)	10 kA

External overvoltage protection

HAW562 or HAW569 from Endress+Hauser are suited as external overvoltage protection.



For detailed information please refer to the following documents:

- HAW562: TI01012K
- HAW569: TI01013K

7.2 Connecting the measuring device

⚠ WARNING

Explosion hazard!

- ▶ Comply with the relevant national standards.
- ▶ Observe the specifications in the Safety Instructions (XA).
- ▶ Only use the specified cable glands.
- ▶ Check whether the supply voltage matches the specifications on the nameplate.
- ▶ Before connecting the device: Switch the supply voltage off.
- ▶ Before switching on the supply voltage: Connect the potential bonding line to the exterior ground terminal.

Required tools and accessories:

- For instruments with safety pin for the lid: AF 3 Allen key
- Wire stripping pliers
- When using stranded wires: Wire end sleeves.

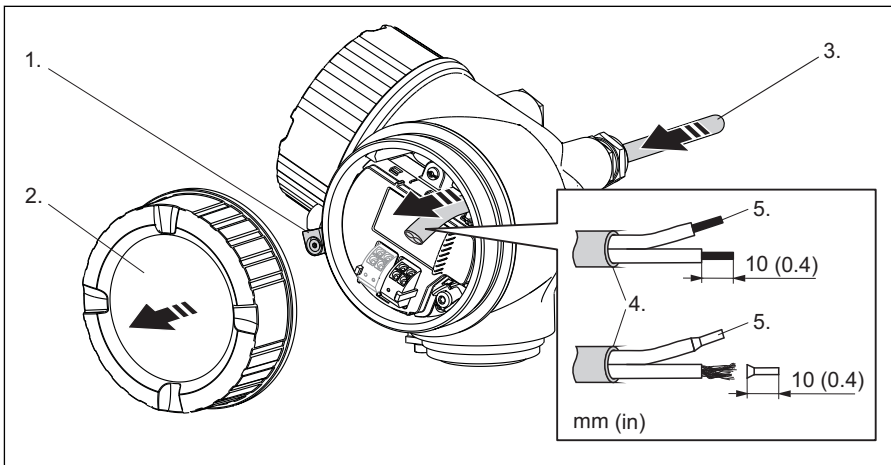

A0012619

1. Loosen the screw of the securing clamp of the connection compartment cover and turn the clamp 90° counterclockwise.
2. Unscrew the connection compartment cover.
3. Push the cable through the cable entry. To ensure tight sealing, do not remove the sealing ring from the cable entry.
4. Strip the cable.
5. Strip the cable ends 10 mm (0.4 in). For stranded cables, also attach wire end ferrules.
6. Firmly tighten the cable glands.

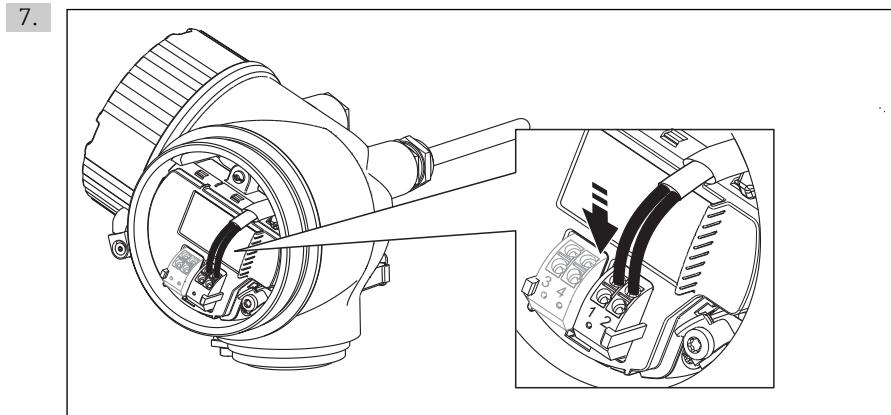

Connect the cable in accordance with the terminal assignment (→  33).

8. When using screened cable: Connect the cable screen to the ground terminal.
9. Screw the cover onto the connection compartment.
10. For instruments with safety pin for the lid: Adjust the safety pin so that its edge is over the edge of the display lid. Tighten the safety pin.

Pluggable spring-force terminals

Instruments without integrated overvoltage protection have pluggable spring-force terminals. Rigid conductors or flexible conductors with cable sleeve can directly be inserted and are contacted automatically.

To remove cables from the terminal: Press on the groove between the terminals using a flat-tip screwdriver ≤ 3 mm (0.12 inch) while pulling the cables out of the terminals.

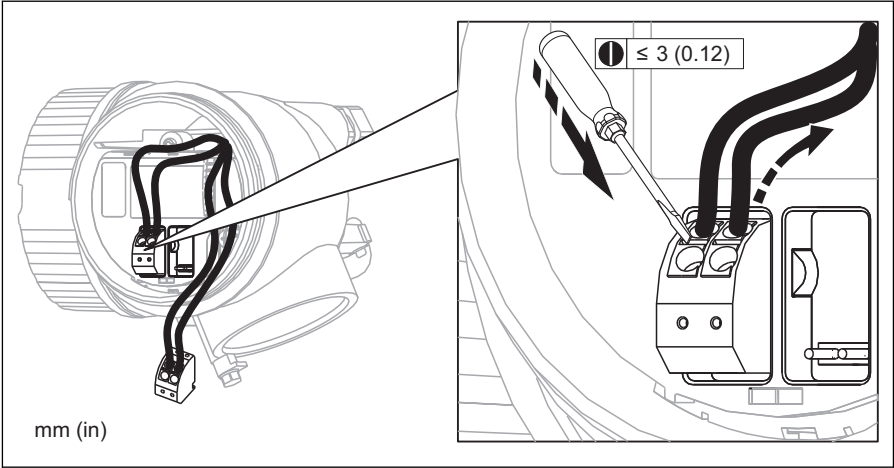

7.3 Post-connection check

<input type="radio"/>	Are cables or the device undamaged (visual inspection)?
<input type="radio"/>	Do the cables comply with the requirements?
<input type="radio"/>	Do the cables have adequate strain relief?
<input type="radio"/>	Are all cable glands installed, firmly tightened and correctly sealed?
<input type="radio"/>	Does the supply voltage match the specifications on the transmitter nameplate?
<input type="radio"/>	Is the terminal assignment correct (→ 33)?
<input type="radio"/>	If required: Is the protective earth connected correctly (→ 33)?
<input type="radio"/>	If supply voltage is present: Is the device ready for operation and do values appear on the display module?
<input type="radio"/>	Are all housing covers installed and firmly tightened?
<input type="radio"/>	Is the securing clamp tightened correctly?

8 Integration into a PROFIBUS network

8.1 Overview of the device database files (GSD)

Manufacturer ID	17 (0x11)
Ident number	0x1559
Profile version	3.02
GSD file	Information and files under:
GSD file version	<ul style="list-style-type: none"> ▪ www.endress.com ▪ www.profibus.org

8.2 Set device address

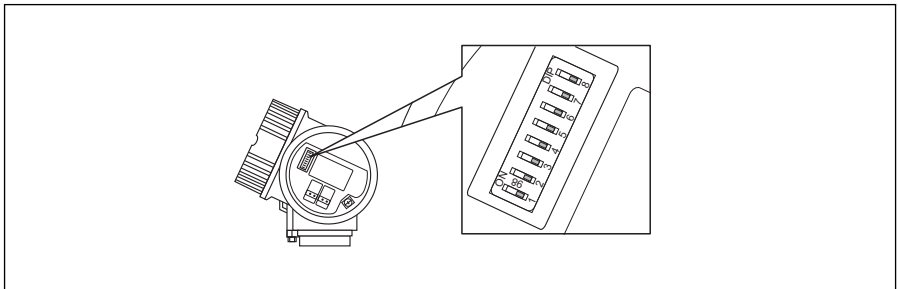

A0015686

 13 Address switches in terminal compartment

8.2.1 Hardware addressing

1. Set switch 8 to "OFF".
2. Define the address with switches 1 to 7 according to the table below.

The address change becomes effective after 10 seconds. The device restarts automatically.

Switch	1	2	3	4	5	6	7
Value in position "ON"	1	2	4	8	16	32	64
Value in position "OFF"	0	0	0	0	0	0	0

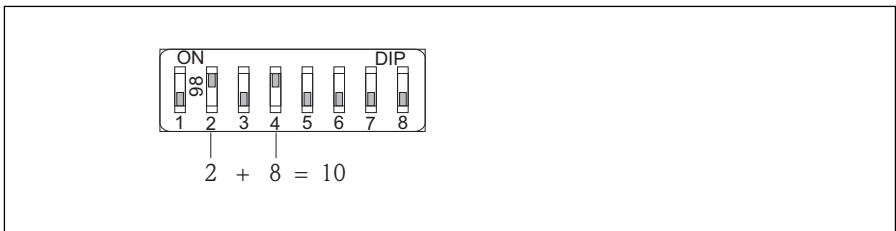

A0015902

- 14 Example of hardware addressing: switch 8 is in position "OFF"; switches 1 to 7 define the address.

8.2.2 Software addressing

1. Set switch 8 to "ON".
2. The device restarts automatically. The address remains the same as before (factory setting: 126).
3. Set the required address via the operating menu: Setup → Device address

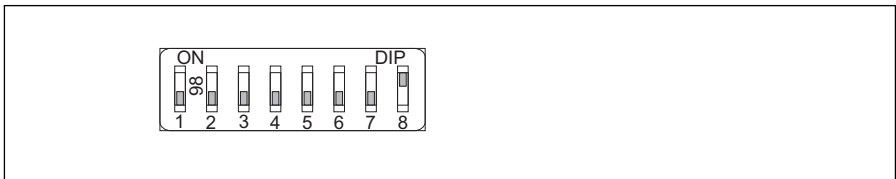

A0015903

- 15 Example of software addressing; switch 8 is in position "ON"; the address is defined in the operating menu (Setup → Device address)

9 Commissioning

9.1 Display and operating module

9.1.1 Display appearance

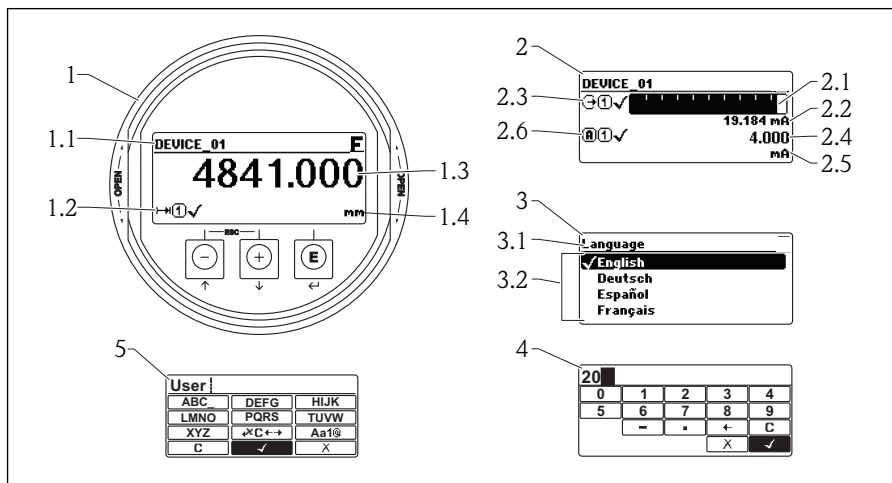







A0012635

16 Appearance of the display and operation module for on-site operation

- 1 Measured value display (1 value max. size)
- 1.1 Header containing tag and error symbol (if an error is active)
- 1.2 Measured value symbols
- 1.3 Measured value
- 1.4 Unit
- 2 Measured value display (1 bargraph + 1 value)
- 2.1 Bargraph for measured value 1
- 2.2 Measured value 1 (including unit)
- 2.3 Measured value symbols for measured value 1
- 2.4 Measured value 2
- 2.5 Unit for measured value 2
- 2.6 Measured value symbols for measured value 2
- 3 Representation of a parameter (here: a parameter with selection list)
- 3.1 Header containing parameter name and error symbol (if an error is active)
- 3.2 Selection list; marks the current parameter value.
- 4 Input matrix for numbers
- 5 Input matrix for alphanumeric and special characters

9.1.2 Operating elements

Key	Meaning
 A0013969	<p>Minus key</p> <p><i>For menu, submenu</i> Moves the selection bar upwards in a picklist.</p> <p><i>For text and numeric editor</i> In the input mask, moves the selection bar to the left (backwards).</p>
 A0013970	<p>Plus key</p> <p><i>For menu, submenu</i> Moves the selection bar downwards in a picklist.</p> <p><i>For text and numeric editor</i> In the input mask, moves the selection bar to the right (forwards).</p>
 A0013952	<p>Enter key</p> <p><i>For measured value display</i></p> <ul style="list-style-type: none"> ■ Pressing the key briefly opens the operating menu. ■ Pressing the key for 2 s opens the context menu. <p><i>For menu, submenu</i></p> <ul style="list-style-type: none"> ■ Pressing the key briefly Opens the selected menu, submenu or parameter. ■ Pressing the key for 2 s for parameter: If present, opens the help text for the function of the parameter. <p><i>For text and numeric editor</i></p> <ul style="list-style-type: none"> ■ Pressing the key briefly <ul style="list-style-type: none"> - Opens the selected group. - Carries out the selected action. ■ Pressing the key for 2 s confirms the edited parameter value.
 A0013971	<p>Escape key combination (press keys simultaneously)</p> <p><i>For menu, submenu</i></p> <ul style="list-style-type: none"> ■ Pressing the key briefly <ul style="list-style-type: none"> - Exits the current menu level and takes you to the next higher level. - If help text is open, closes the help text of the parameter. ■ Pressing the key for 2 s returns you to the measured value display ("home position"). <p><i>For text and numeric editor</i> Closes the text or numeric editor without applying changes.</p>
 A0013953	<p>Minus/Enter key combination (press and hold down the keys simultaneously)</p> <p>Reduces the contrast (brighter setting).</p>
 A0013954	<p>Plus/Enter key combination (press and hold down the keys simultaneously)</p> <p>Increases the contrast (darker setting).</p>
 A0013955	<p>Minus/Plus/Enter key combination (press and hold down the keys simultaneously)</p> <p><i>For measured value display</i> Enables or disables the keypad lock.</p>

9.2 Operating menu

Parameter/Submenu	Meaning	Description
Language ¹⁾	Defines the operating language of the on-site display.	BA01124F (FMR50, PROFIBUS PA)
Setup	When appropriate values have been assigned to all setup parameters, the measured should be completely configured in a standard application.	
Setup → Mapping	Interference echo suppression	
Setup → Advanced setup	Contains further submenus and parameters: <ul style="list-style-type: none"> ▪ to adapt the device to special measuring conditions. ▪ to process the measured value (scaling, linearization). ▪ to configure the signal output. 	
Diagnostics	Contains the most important parameters needed to detect and analyze operational errors.	
Expert ²⁾	Contains all parameters of the device (including those which are already contained in one of the above submenus). This menu is organized according to the function blocks of the device.	GP01018F/00/DE (Description of Device Parameters, FMR5x, PROFIBUS PA)

- 1) In case of operation via operating tools (e.g. FieldCare), the "Language" parameter is located at "Setup → Advanced Setup → Display"
- 2) On entering the "Expert" menu, a access code is always requested. If a customer specific access code has not been defined, "0000" has to be entered.

9.3 Unlock the device

If the device has been locked, it must be unlocked before the measurement can be configured.

 For details refer to the Operating Instructions of the device:
BA01124F (FMR50, PROFIBUS PA)

9.4 Setting the operating language

Factory setting: English or ordered local language

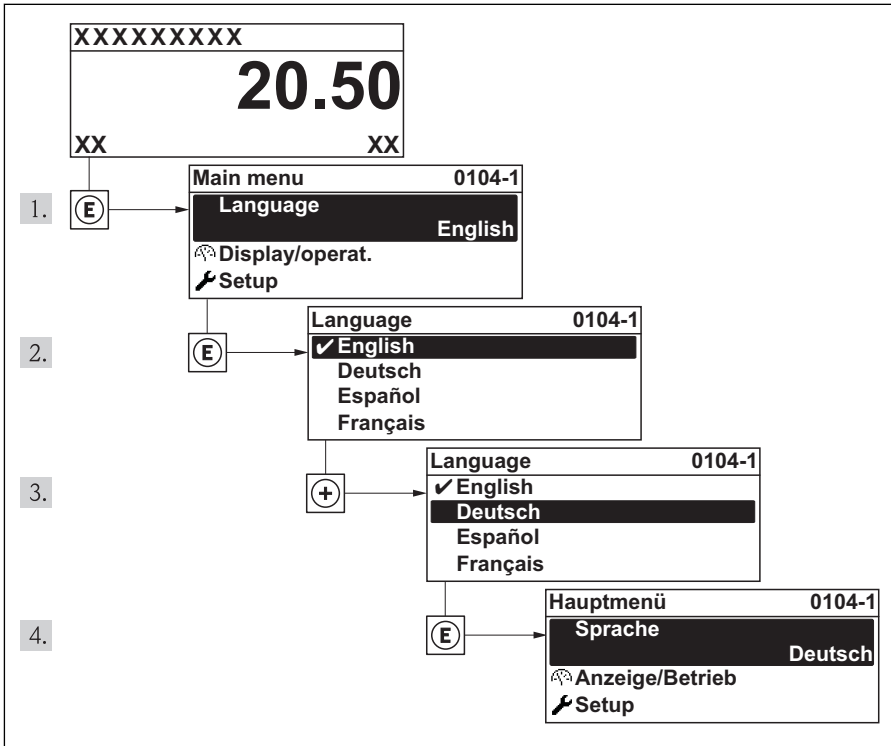

A0013996

 17 Taking the example of the local display

9.5 Configuration of a level measurement

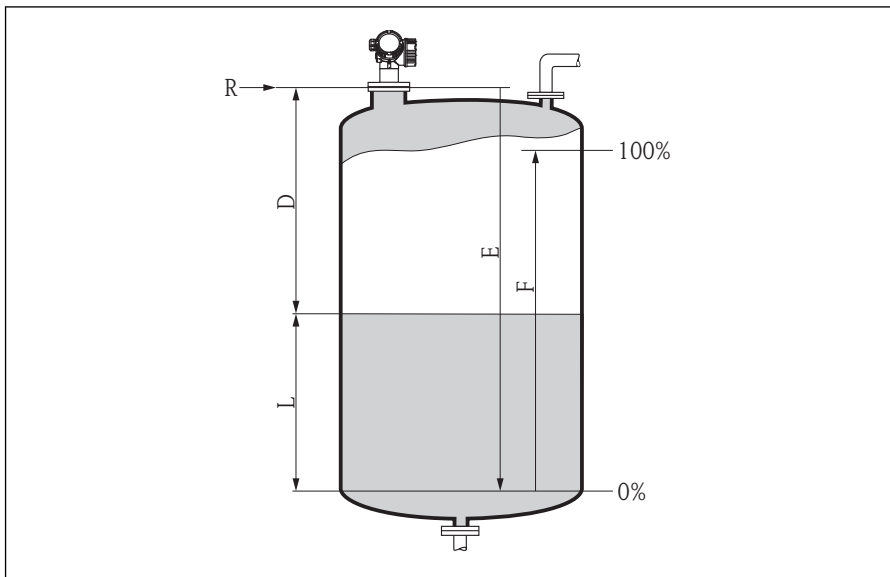

A0016933

1. **Setup → Tag description**
 - ↳ Enter tag for measuring point.
2. **Setup → Device address**
 - ↳ Enter bus address of the device (only in case of software addressing).
3. **Setup → Distance unit**
 - ↳ Select distance unit.
4. **Setup → Tank type**
 - ↳ Select tank type.
5. **Setup → Tube diameter** (only for "Tank type" = "Bypass/pipe")
 - ↳ Enter the diameter of the stilling well or bypass.
6. **Setup → Medium group**
 - ↳ Specify medium group ("Water based": DC>4 or "Others": DC>1,9)
7. **Setup → Empty calibration**
 - ↳ Enter empty distance E (Distance from reference point R to the 0% level)³⁾.

3) If, for example, the measuring range covers only an upper part of the tank ($E \ll$ tank height), it is mandatory to enter the actual tank height into the "Setup → Advanced Setup → Level → Tank/silo height" parameter.

8. **Setup → Full calibration**
 - ↳ Enter full distance F (Distance from the 0% to the 100% level).
9. **Setup → Level**
 - ↳ Indicates the measured level L.
10. **Setup → Distance**
 - ↳ Indicates the measured distance from the reference point R to the level L.
11. **Setup → Signal quality**
 - ↳ Indicates the quality of the evaluated level echo.
12. **Setup → Mapping → Confirm distance**
 - ↳ Compare distance indicated on the display to real distance in order to start the recording of an interference echo map.
13. **Setup → Advanced setup → Level → Level unit**
 - ↳ Select level unit: %, m, mm, ft, in (Factory setting: %)



The response time of the device is preset by the **Tank type** parameter. An enhanced setting is possible in the **Advanced setup** submenu.

9.6 User-specific applications



For details of setting the parameters of user-specific applications, see separate documentation:

BA01124F (Operating Instructions, FMR50, PROFIBUS PA)



For the **Expert** submenu refer to:

GP01018F/00/EN (Description of Device Parameters, FMR5x, PROFIBUS PA)



71217610

www.addresses.endress.com
