

# Safety Instructions

## Soliphant M

### FTM50, FTM51, FTM52

Ex ta/tb IIC T93°C Da/Db

Ex ta/tb [ia Da] IIC T93°C Da/Db

Ex tb [ia Da] IIC T93°C Db



Document: XA01336F-B

Safety instructions for electrical apparatus for explosion-hazardous areas → 3

---

# Soliphant M FTM50, FTM51, FTM52

## Table of contents

Associated documentation . . . . .	4
Supplementary documentation . . . . .	4
Manufacturer's certificates . . . . .	4
Manufacturer address . . . . .	4
Extended order code . . . . .	4
Safety instructions: General . . . . .	6
Safety instructions: Special conditions . . . . .	6
Safety instructions: Installation . . . . .	7
Temperature tables . . . . .	8
Connection data . . . . .	12

<b>Associated documentation</b>	<p>This document is an integral part of the following Operating Instructions:</p> <ul style="list-style-type: none"> <li>■ KA00229F/00 (FTM50, FTM51)</li> <li>■ KA00230F/00 (FTM52)</li> </ul>										
<b>Supplementary documentation</b>	<p>Explosion-protection brochure: CP00021Z/11</p> <p>The Explosion-protection brochure is available:</p> <ul style="list-style-type: none"> <li>■ In the download area of the Endress+Hauser website:  <a href="http://www.endress.com">www.endress.com</a> -&gt; Downloads -&gt; Media Type: Documentation -&gt;  Documentation Type: Brochures and catalogs -&gt; Text Search: CP00021Z</li> <li>■ On the CD for devices with CD-based documentation</li> </ul>										
<b>Manufacturer's certificates</b>	<p><b>Certificate of Conformity</b></p> <p>Certificate number: TÜV 13.2012 X</p> <p>Affixing the certificate number certifies conformity with the following standards (depending on the device version):</p> <ul style="list-style-type: none"> <li>■ ABNT NBR IEC 60079-0 : 2013</li> <li>■ ABNT NBR IEC 60079-11 : 2013</li> <li>■ ABNT NBR IEC 60079-31 : 2014</li> </ul>										
<b>Manufacturer address</b>	<p>Endress+Hauser GmbH+Co. KG Hauptstraße 1 79689 Maulburg, Germany Address of the manufacturing plant: See nameplate.</p>										
<b>Extended order code</b>	<p>The extended order code is indicated on the nameplate, which is affixed to the device in such a way that it is clearly visible. Additional information about the nameplate is provided in the associated Operating Instructions.</p> <p><b>Structure of the extended order code</b></p> <table border="0" style="margin-left: 40px;"> <tr> <td style="text-align: center;">FTM5x</td> <td style="text-align: center;">-</td> <td style="text-align: center;">*****</td> <td style="text-align: center;">+</td> <td style="text-align: center;">A*B*C*D*E*F*G*..</td> </tr> <tr> <td style="text-align: center;"><i>(Device type)</i></td> <td></td> <td style="text-align: center;"><i>(Basic specifications)</i></td> <td></td> <td style="text-align: center;"><i>(Optional specifications)</i></td> </tr> </table> <p>* = Placeholder At this position, an option (number or letter) selected from the specification is displayed instead of the placeholders.</p> <p><i>Basic specifications</i></p> <p>The features that are absolutely essential for the device (mandatory features) are specified in the basic specifications. The number of positions depends on the number of features available. The selected option of a feature can consist of several positions.</p> <p><i>Optional specifications</i></p> <p>The optional specifications describe additional features for the device (optional features). The number of positions depends on the number of features available. The features have a 2-digit structure to aid identification (e.g. JA). The first digit (ID) stands for the feature group and consists of a number or a letter (e.g. J = Test, Certificate). The second digit constitutes the value that stands for the feature within the group (e.g. A = 3.1 material (wetted parts), inspection certificate).</p>	FTM5x	-	*****	+	A*B*C*D*E*F*G*..	<i>(Device type)</i>		<i>(Basic specifications)</i>		<i>(Optional specifications)</i>
FTM5x	-	*****	+	A*B*C*D*E*F*G*..							
<i>(Device type)</i>		<i>(Basic specifications)</i>		<i>(Optional specifications)</i>							

More detailed information about the device is provided in the following tables. These tables describe the individual positions and IDs in the extended order code which are relevant to hazardous locations.

### Extended order code: Soliphant M



The following specifications reproduce an extract from the product structure and are used to assign:

- This documentation to the device (using the extended order code on the nameplate).
- The device options cited in the document.

#### Device type

FTM50, FTM51, FTM52

#### Basic specifications

Position 1 (Approval)		
Selected option		Description
FTM50	M	INMETRO Ex ta/tb IIIC T93°C Da/Db
FTM51		INMETRO Ex tb [ia Da] IIIC T93°C Db <sup>1)</sup>
FTM52	M	INMETRO Ex ta/tb [ia Da] IIIC T93°C Da/Db
		INMETRO Ex tb [ia Da] IIIC T93°C Db <sup>1)</sup>

1) Only in connection with Position 7 (Type of Probe) = D, E, G, H

Position 6 (Electronics; Output)		
Selected option		Description
FTM5x	1	FEM51; 2-wire 19-253VAC
	2	FEM52; 3-wire PNP 10-55VDC
	4	FEM54; relay DPDT, 19-253VAC/55VDC
	5	FEM55; 8/16mA, 11-36VDC

Position 7 (Type of Probe)		
Selected option		Description
FTM5x	A	Compact
	D, E	Cable > separate housing
	G, H	Cable, armoured > separate housing

Position 8 (Housing)		
Selected option		Description
FTM5x	H	T13 Alu IP66/68 NEMA Type 4X Encl., separate conn. compartment
	3	F17 Alu IP66/67 NEMA Type 4X Encl.
	5	F13 Alu IP66/68 NEMA Type 4X Encl.
	6	F27 316L IP67/68 NEMA Type 4X/6P Encl.
	7	F15 316L hygiene IP66/67

Position 11 (Additional Option 2)		
Selected option		Description
FTM50	A	Not selected
FTM51	C	EN10204-3.1 material (wetted parts), inspection certificate
	D, E	Temp. separator $\leq 150^{\circ}\text{C}$
	F, H	High temperature $\leq 280^{\circ}\text{C}$
	J, K	High temperature $\leq 230^{\circ}\text{C}$
	Y	Special version: High temperature $\leq 300^{\circ}\text{C}$
FTM52	A	Not selected

#### Optional specifications

No options specific to hazardous locations are available.

#### Safety instructions: General

- Staff must meet the following conditions for mounting, electrical installation, commissioning and maintenance of the device:
  - Be suitably qualified for their role and the tasks they perform
  - Be trained in explosion protection
  - Be familiar with national regulations
- Install the device according to the manufacturer's instructions and national regulations.
- Do not operate the device outside the specified electrical, thermal and mechanical parameters.
- Only use the device in media to which the wetted materials have sufficient durability.
- Avoid electrostatic charging:
  - Of plastic surfaces (e.g. housing, sensor element, special varnishing, attached additional plates, ..)
  - Of isolated capacities (e.g. isolated metallic plates)
- Refer to the temperature tables for the relationship between the permitted ambient temperature for the sensor and/or transmitter, depending on the range of application and the temperature class.
- Modifications to the device can affect the explosion protection and must be carried out by staff authorized to perform such work by Endress+Hauser.

#### Safety instructions: Special conditions

- In the event of additional or alternative special varnishing on the housing or other metal parts:
- Observe the danger of electrostatic charging and discharge.
  - Do not rub surfaces with a dry cloth.

**Safety instructions:**  
**Installation**

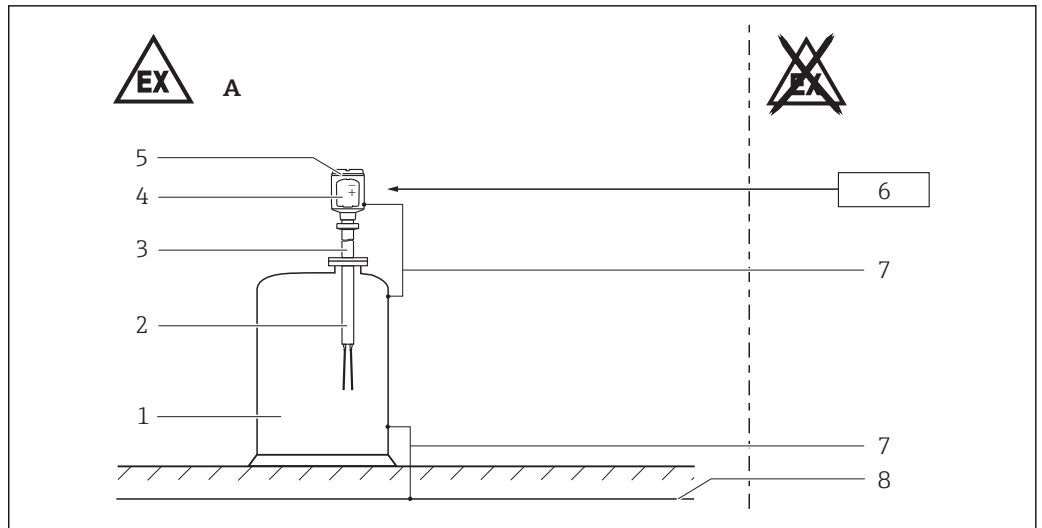

A0027391

1

- A Zone 21
- 1 Tank; Hazardous area Zone 20
- 2 Version
- 3 Temperature separator (optional at 150 °C)
- 4 Electronic insert; Electronic compartment Ex tb
- 5 Housing
- 6 Power supply
- 7 Potential equalization line
- 8 Potential equalization

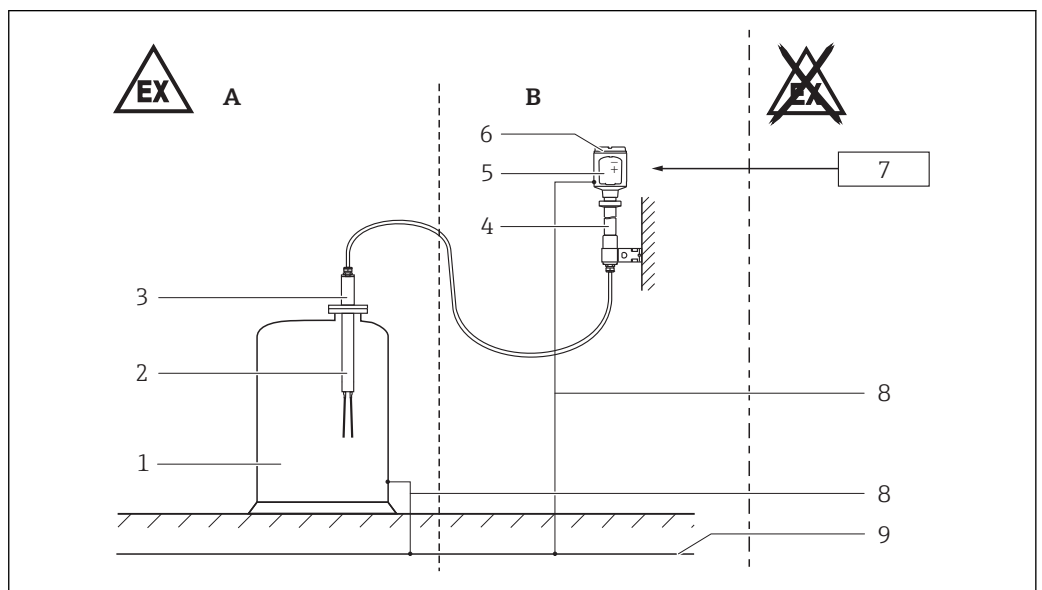

A0027392

2

- A Zone 20, Zone 21
- B Zone 21
- 1 Tank; Hazardous area Zone 20
- 2 Version
- 3 Sensor housing
- 4 Temperature separator (optional at 150 °C)
- 5 Electronic insert; Electronic compartment Ex tb
- 6 Electronics housing
- 7 Power supply
- 8 Potential equalization line
- 9 Potential equalization

- After mounting and connecting the sensor, ingress protection of the housing must be at least IP65.
- Perform the following to achieve the degree of protection IP66/67 or IP66/68:
  - Screw the cover tight.
  - Mount the cable entry correctly.
- Use a process connection seal that meets the materials compatibility and temperature requirements.
- When connecting the cables, ensure there is adequate strain relief at place of installation.
- Protect the connecting cable between the separate housing and the level sensor from tension and friction (e.g. due to electrostatic charge from medium flow).
- Observe the maximum process conditions according to the manufacturer's Operating Instructions.
- At high medium temperatures, note flange pressure load capacity as a factor of temperature.
- Max. heat-up of device surface in Zone 20 under fault conditions:  $\leq 10$  K (measured with deposited material with a layer  $>50$  mm in thickness).
- Max. heat-up of device surface in Zone 21 or Zone 22 under fault conditions:  $\leq 23$  K.
- Install the device to exclude any mechanical damage or friction during the application. Pay particular attention to flow conditions and tank fittings.
- Support extension tube of the device if a dynamic load is expected.
- Only use certified cable entries suitable for the application. Observe national regulations and standards.
- When operating the transmitter housing at an ambient temperature under  $-20$  °C, use appropriate cables and cable entries permitted for this application.
- Seal unused entry glands with approved sealing plugs that correspond to the type of protection. The plastic transport sealing plug does not meet this requirement and must therefore be replaced during installation.
- Continuous service temperature of the connecting cable:  $-50$  °C to  $\geq +93$  °C; in accordance with the range of service temperature taking into account additional influences of the process conditions ( $T_{a,\min}$ ), ( $T_{a,\max} + 23$  K).
- Before operation:
  - Screw in the cover all the way.
  - Tighten the securing clamp on the cover.
- In potentially explosive atmospheres:
  - Do not disconnect the electrical connection of the power supply circuit when energized.
  - Do not open the connection compartment cover and the electronics compartment cover when energized.

#### Accessory high pressure sliding sleeve

The high pressure sliding sleeve can be used for a continuous setting of the switch point and is suited for zone division if mounted properly (see Operating Instructions).

#### Potential equalization

Integrate the device into the local potential equalization.

#### Temperature tables

##### Compact version

Basic specification, Position 7 (Type of Probe) = A

Basic specification, Position 1 (Approval) = M

Ex ta/tb IIIC T93°C Da/Db

Device type FTM50, FTM51

Position 11 (Additional Option 2)	Permissible process temperature $T_p$	Maximum surface temperature		Permissible ambient temperature $T_a$
		Fork, Zone 20	Housing, Zone 21/22	
A, C, D, E	$-50$ to $+150$ °C	$T_{p,\max} + 10$ K	$T_{a,\max} + 23$ K	$-50$ to $+70$ °C
F, H	$-50$ to $+280$ °C	$T_{p,\max} + 10$ K	$T_{a,\max} + 23$ K	$-50$ to $+70$ °C
J, K	$-50$ to $+230$ °C	$T_{p,\max} + 10$ K	$T_{a,\max} + 23$ K	$-50$ to $+70$ °C



Basic specification, Position 1 (Approval) = M  
 Ex ta/tb [ia Da] IIIC T93°C Da/Db

Device type FTM52

Position 11 (Additional Option 2)	Permissible process temperature $T_p$	Maximum surface temperature		Permissible ambient temperature $T_a$ Housing
		Fork, Zone 20	Housing, Zone 21/22	
A	-40 to +80 °C	$T_{p,max} +10$ K	$T_{a,max} +23$ K	-40 to +70 °C

Device type FTM50, FTM51

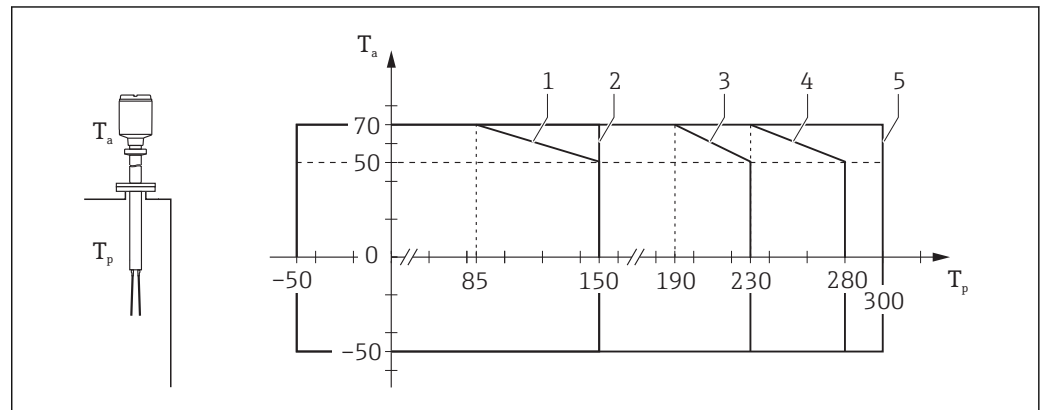

A0027393

3

$T_a$  Ambient temperature in °C

$T_p$  Process temperature in °C

- 1 Basic specification, Position 11 (Additional Option 2) = A, C, D, E, without temperature separator
- 2 Basic specification, Position 11 (Additional Option 2) = A, C, D, E, with temperature separator
- 3 Basic specification, Position 11 (Additional Option 2) = J, K, with temperature separator inside the insulation
- 4 Basic specification, Position 11 (Additional Option 2) = F, H, with temperature separator inside the insulation
- 5 Basic specification, Position 11 (Additional Option 2) = Y, with temperature separator outside the insulation

Device type FTM52

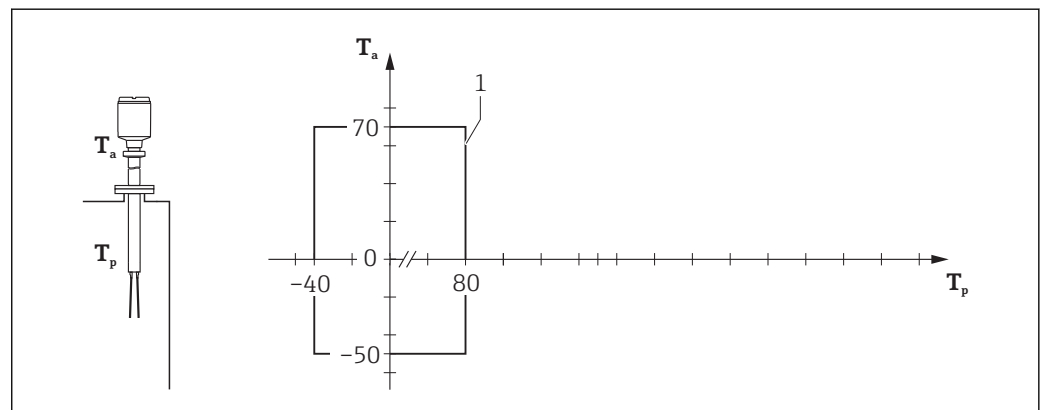

A0027395

4

$T_a$  Ambient temperature in °C

$T_p$  Process temperature in °C

- 1 Basic specification, Position 11 (Additional Option 2) = A

**Version with separate housing**

Basic specification, Position 7 (Type of Probe) = D, E, G, H (Sensor)

Basic specification, Position 1 (Approval) = M

Ex ia IIIC Txx°C+10K Da/Db

Device type FTM50, FTM51

Position 11 (Additional Option 2)	Permissible process temperature $T_p$ Fork	Maximum surface temperature		Permissible ambient temperature $T_a$ Sensor housing
		Fork, Zone 20	Sensor housing, Zone 20/21/22	
A, C, D, E	-50 to +150 °C	$T_{p,max} + 10\text{ K}$	$T_{a,max} + 10\text{ K}$	-50 to +120 °C
F, H	-50 to +280 °C	$T_{p,max} + 10\text{ K}$	$T_{a,max} + 10\text{ K}$	-50 to +120 °C
J, K	-50 to +230 °C	$T_{p,max} + 10\text{ K}$	$T_{a,max} + 10\text{ K}$	-50 to +120 °C

Device type FTM52

Position 11 (Additional Option 2)	Permissible process temperature $T_p$ Fork	Maximum surface temperature		Permissible ambient temperature $T_a$ Sensor housing
		Fork, Zone 20	Sensor housing, Zone 20/21/22	
A	-40 to +80 °C	$T_{p,max} + 10\text{ K}$	$T_{a,max} + 10\text{ K}$	-40 to +80 °C

Basic specification, Position 7 (Type of Probe) = D, E, G, H (Housing)

Basic specification, Position 1 (Approval) = M

Ex tb [ia Da] IIIC T93°C Db

Device type FTM50, FTM51, FTM52

Max. surface temperature ( $T_{a,max}$ ) Electronics housing, Zone 21/22	Permissible ambient temperature $T_a$ Electronics housing
+23 K	-50 to +70 °C

Device type FTM50, FTM51

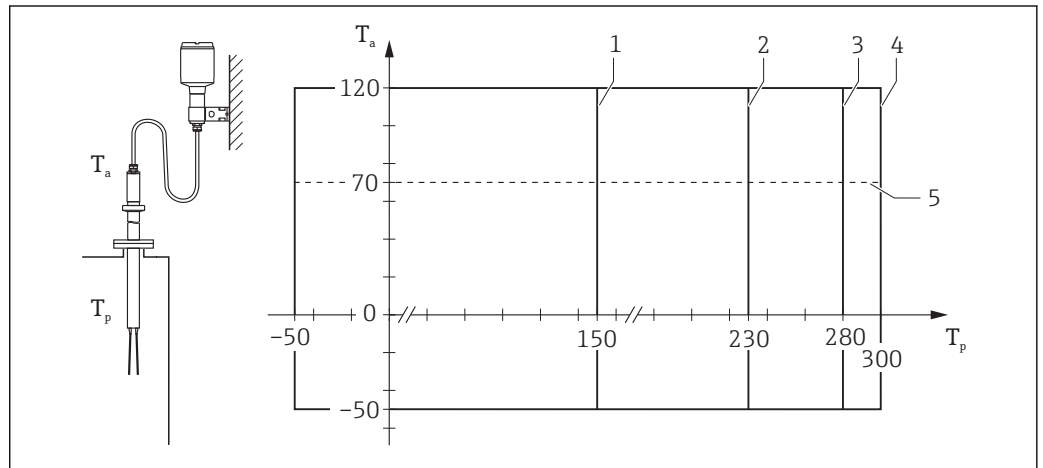

A0027396

5

- $T_a$  Ambient temperature in °C
- $T_p$  Process temperature in °C
- 1 Basic specification, Position 11 (Additional Option 2) = A, C, D, E
- 2 Basic specification, Position 11 (Additional Option 2) = J, K, with temperature separator
- 3 Basic specification, Position 11 (Additional Option 2) = F, H, with temperature separator
- 4 Basic specification, Position 11 (Additional Option 2) = Y, with temperature separator
- 5  $T_a$  at housing: Restriction to 70 °C

Device type FTM52

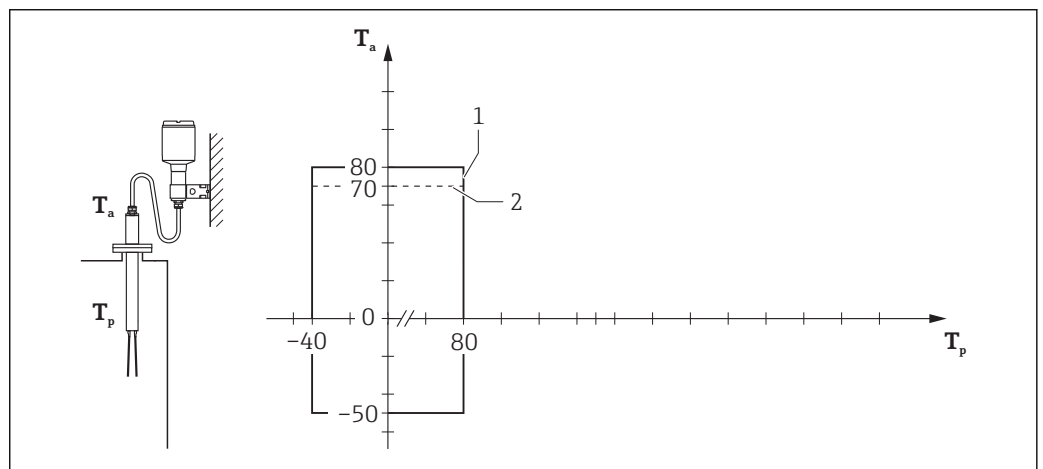

A0027397

6

- $T_a$  Ambient temperature in °C
- $T_p$  Process temperature in °C
- 1 Basic specification, Position 11 (Additional Option 2) = A
- 2  $T_a$  at housing: Restriction to 70 °C

## Connection data

<i>Position 6 (Electronics; Output)</i>	<b>Supply</b>	<b>Output</b>
1	19 to 253 V <sub>AC</sub> , 50/60 Hz, max. 1.0 W U <sub>m</sub> = 253 V <sub>AC</sub>	max. 350 mA
2	10 to 55 V <sub>DC</sub> , max. 0.86 W U <sub>m</sub> = 253 V <sub>AC</sub>	PNP transistor, max. 350 mA
4	19 to 55 V <sub>DC</sub> , max. 1.5 W 19 to 253 V <sub>AC</sub> , 50/60 Hz, max. 1.5 W U <sub>m</sub> = 253 V <sub>AC</sub>	2 potential free change-over contacts, 253 V <sub>AC</sub> , 6 A; 1 500 VA / cos φ = 1; 750 VA cos φ > 0.7 30 V <sub>DC</sub> , 6 A; 125 V <sub>DC</sub> , 0.2 A
5	11 to 36 V <sub>DC</sub> , 8/16 mA, max. 0.6 W U <sub>m</sub> = 253 V <sub>AC</sub>	<3.6 mA / 8 mA / 16 mA



---





71362372

[www.addresses.endress.com](http://www.addresses.endress.com)

---