

Safety Instructions

Proline Promag 53

NEPSI Zone 1, Zone 21

This document is an integral part of the following Operating Instructions:

- BA00047D, Proline Promag 53 HART
- BA00051D, Proline Promag 53 FOUNDATION Fieldbus
- BA00053D, Proline Promag 53 PROFIBBUS DP/PA
- BA00117D, Proline Promag 53 Modbus RS485

Contents

General warnings	2
Special conditions	2
Installation instructions	2
COC certificates of conformity	4
Description of measuring system	4
Nameplates	5
Type code	6
Temperature table compact version	8
Temperature table remote version	8
Gas and dust explosion protection	9
Design of measuring system	9
Cable entries	10
Cable specification	10
Potential equalization	10
Connection of remote version connecting cable	11
Electrical connection	12
Terminal assignment and connection data, power supply	12
Terminal assignment and connection data for signal circuits (intrinsically safe circuits)	13
Terminal assignment and connection data for signal circuits (non-intrinsically safe circuits)	15
Service adapter	17
Device fuse	17
Technical Data	17

General warnings

- For installation, use and maintenance of the flow meter, the instruction manual and the following standards shall be observed:
 - GB50257-2014 "Code for construction and acceptance of electric device for explosive atmospheres and fire hazard electrical equipment installation engineering"
 - GB3836.13-2013 "Explosive atmospheres- Part 13: Equipment repair, overhaul and reclamation".
 - GB3836.15-2000 "Electrical apparatus for explosive gas atmospheres – Part 15: Electrical installations in hazardous area (other than mines)"
 - GB3836.16-2006 "Electrical apparatus for explosive gas atmospheres – Part 16: Inspection and maintenance of electrical installation (other than mines)"
 - GB3836.18-2010 "Explosive atmospheres- Part 18: Intrinsically safe system".
 - GB15577-2007: Safety regulations for dust explosion prevention and protection". (Only if installed in dust hazardous areas.)
 - GB12476.2-2010 "Electrical apparatus for use in the presence of combustible dust- Part 2: Selection and installation". (Only if installed in dust hazardous areas)
- The flow meter shall not be modified in order to ensure the explosion protection performance of the equipment. Any change may impair safety.
- Installation, connection to the electricity supply, commissioning and maintenance of the devices must be carried out by qualified specialists trained to work on Ex-rated devices.
- Compliance with all of the technical data of the device (see nameplate) is mandatory.
- Open the device only when it is de-energized (and after a delay of at least 10 minutes following shutdown of the power supply) or in non-hazardous (classified) locations.
- It is not permissible to connect the service adapter whilst the atmosphere is considered to be explosive.
- Opening the transmitter housing and the connection housing of the remote version is only permitted for a brief time. During this time, ensure that no dust or water enters the housing.
- To guarantee resistance to dust and water, the transmitter housing, the connection housing of the remote version and the cable entries must be tightly sealed.
- The suitability of the device in the event of simultaneous occurrence of gas-air and dust-air mixtures requires an additional assessment.

Special conditions

- The device must be integrated into the potential equalization system. Potential must be equalized along the intrinsically safe sensor circuits. Further information is provided in the "Potential equalization" section on →  10.
- The sensors may only be used for those media, for which the wetted parts are known to be suitable.
- For the application of the transmitters in an ambient temperature of less than -20 °C suitable cables and cable entries certified for this condition shall be used. Entry holes which are not needed, shall be closed by stopping plugs separately certified for this purpose.

Installation instructions

- For terminals No. 20 to No. 27 of the transmitter, only devices with ratings $U_m \leq 260\text{ V}$ and $I_m \leq 500\text{ mA}$ are allowed to be connected (does not apply to intrinsically safe circuits).
- The measuring device must only be used in the permitted temperature class.
The values of the individual temperature classes can be found in the temperature tables →  8.
For Zone 21: The surface temperature of the measuring device must not exceed 2/3 of the ignition temperature of a dust cloud. The maximum surface temperature must maintain a safe distance of 75 °C to the smolder temperature of a dust layer of 5 mm.
Example: Operation in temperature class T4 (135 °C) is, therefore, suitable for dust with an ignition temperature of 202.5 °C ($1.5 \times 135\text{ °C}$ or $135\text{ °C} = 2/3$ of 202.5 °C) and a smolder temperature of 210 °C ($135\text{ °C} + 75\text{ °C}$).
- The following applies when using the terminal compartment in type of protection "flameproof/Ex d": Only cable entries and cable glands, which are approved by ExTL in accordance with GB3836.1-2010 and GB3836.2-2010 and which are suitable for an operating temperature of up to 80 °C , they shall be used.

- The following applies when using the terminal compartment in type of protection "increased safety/Ex e":
Only cable entries, cable glands and blanking plugs, which are approved by ExTL in accordance with GB3836.1-2010 and GB3836.3-2010 and which are suitable for an operating temperature of up to 80 °C and for an ingress protection of IP67, they shall be used. Alternatively Ex e cable glands specified or provided by Endress+Hauser Flowtec AG can be used. The cables must be installed in such a way, that they are fixed in place in order to ensure adequate strain relief.
- Suitable cables and suitable, certified cable glands, cable entries and blanking plugs must be used for measuring devices operated at temperatures below -20 °C.
- The cable entries and openings not used must be sealed tight with suitable components.
- Turning the transmitter housing: Recesses for centering the worm screw are provided to prevent inadvertent movement of the transmitter housing. It is permissible to turn the transmitter housing through a maximum of 180° during operation (in either direction), without compromising explosion protection. After turning the housing the worm screw must be tightened again.
- Turning the local display:
the screw cap has to be removed before the local display can be turned, and this must be done with the device de-energized (and after a delay of at least 10 minutes following shutdown of the power supply) or when the area is known to be non-hazardous.
- When connecting the intrinsically safe circuits of explosion protection category "ia" of the measuring device to certified intrinsically safe circuits of explosion protection category "ib" with the explosion group IIC and IIB respectively, the explosion protection changes to Ex ib IIC and Ex ib IIB respectively.
- If the active intrinsically safe communication circuits (input/output option S, terminals 26/27) are fed into areas that require 2D apparatus, the connected apparatus must be tested and certified accordingly.



Caution!

The explosion group for the measuring device can be IIC. However, it is reduced to IIB if the permitted, external capacitance/inductance for the intrinsically safe communication circuits is increased (see → 14).

Warning!

For entity concept, the criteria for interconnection between the I/O circuits and the associated circuits is as follow:

- $U_o \leq U_i$
- $I_o \leq I_i$
- $P_o \leq P_i$
- $C_o \geq C_i + C_c$
- $L_o \geq L_i + L_c$

C_c and L_c stand for the distributed capacitance and distributed inductance of the cable.

Turning the transmitter housing

1. Unscrew the grub screw.
2. Rotate the transmitter housing cautiously clockwise until the end stop (end of the thread).
3. Rotate the transmitter housing counter-clockwise (max. 360°) in the wanted position.
4. Tighten the grub screw properly after each manipulation

Warning!

Ensure that the grub screw is tightened properly.

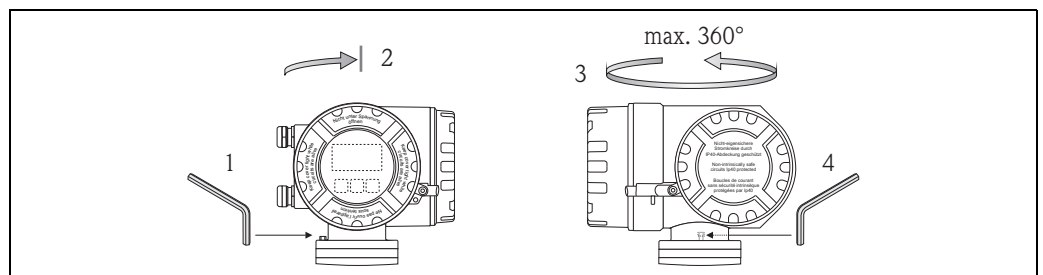

Fig. 1: Turning the transmitter housing

A0006944

COC certificates of conformity

By affixing the certification number the product conforms with the following standards:

- GB3836.1-4 – 2010
- GB3836.20 – 2010
- GB12476.1 – 2013
- GB12476.5 – 2013

Certification numbers:

- GYJ17.1165X

Inspection body

NEPSI, National Supervision and Inspection Centre for Explosion Protection and Safety of Instrumentation

Description of measuring system

The measuring system consists of transmitters and sensors.

Two versions are available:

- Compact version: transmitters and sensors form a mechanical unit.
- Remote version: transmitters and sensors are installed separately and connected to each other via connecting cables.

Nameplates

The nameplates, which are mounted in a clearly visible position on the transmitter and sensor, contain all of the relevant information about the measuring system.

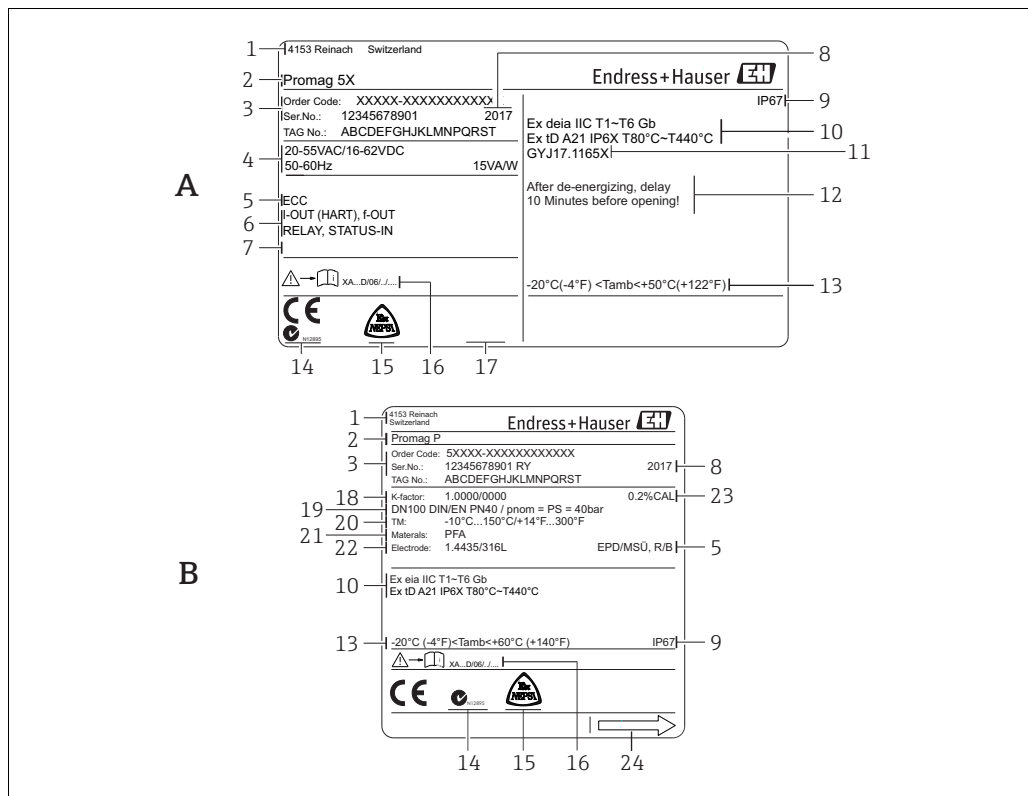

A0008261

Fig. 2: Example for nameplates of a transmitter and of a sensor, compact version

A Transmitter nameplate

B Sensor nameplate

- 1 Manufacturer / Certificate recipient
- 2 Transmitter or sensor type
- 3 Order code and serial number
- 4 Power supply, frequency and power consumption
- 5 Additional specification, e.g. ECC = Electrode cleaning circuitry, EPD = empty pipe detection, R/B = reference electrode, etc. (only if present)
- 6 Available inputs/outputs
- 7 Space for additional information on special products
- 8 Year of manufacture
- 9 Type of enclosure protection
- 10 Type of protection
- 11 Number of the NEPSI certificate of conformity
- 12 Space for notes, e.g. delays, etc. (only if necessary)
- 13 Ambient temperature range
- 14 C-Tick symbol
- 15 NEPSI Symbol
- 16 Associated Ex documentation
- 17 Space for other approval specifications and certificates, e.g. PROFIBUS, etc. (only if present)
- 18 Calibration factor/zero point
- 19 Nominal diameter/nominal pressure
- 20 Fluid temperature range
- 21 Materials in contact with the medium
- 22 Measuring electrode material
- 23 Calibration tolerance
- 24 Direction of flow

Type code

The type code describes the exact design and the equipment of the measuring system. It can be read on the nameplate of the transmitter and sensor and is structured as follows:

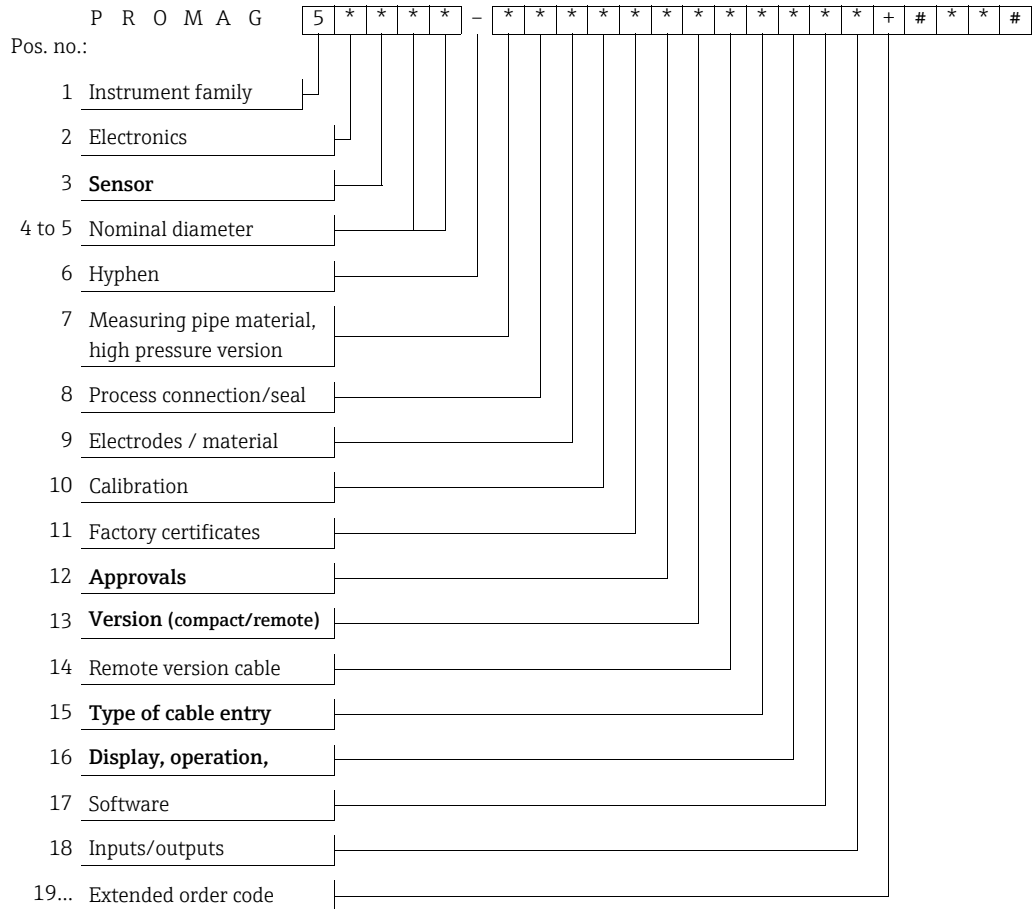

Electronics (Item No. 2 in type code)

*	Transmitter	Type of explosion protection
3	Promag 53	<ul style="list-style-type: none"> Transmitter electronics: [Ex ia] IIC Transmitter housing: Ex d or Ex de IIC

Sensor (Item No. 3 in type code)

*	Sensor	Lining
W, P, H	Promag W	<ul style="list-style-type: none"> Hard rubber Polyurethane
	Promag P	<ul style="list-style-type: none"> PFA PTFE
	Promag H	<ul style="list-style-type: none"> PFA

Approvals (Item No. 12 in type code)

*	Type of explosion protection			
	Transmitter			Sensor
	Remote version	Compact version with Ex ia input/output	Compact version other	
K ¹⁾	Ex de[ia Ga] IIC/IIB T6 Gb Ex tD A21 IP6X T80°C	Ex deia[ia Ga] IIC/IIB T1~T6 Gb Ex tD A21 IP6X T80°C~T440°C	Ex deia IIC/IIB T1~T6 Gb Ex tD A21 IP6X T80°C~T440°C	Ex eia IIC/IIB T1~T6 Gb Ex tD A21 IP6X T80°C~T440°C
S ²⁾	Ex de[ia Ga] IIC/IIB T6 Gb Ex tD A21 IP6X T80°C	Ex deia[ia Ga] IIC/IIB T1~T6 Gb Ex tD A21 IP6X T80°C~T440°C	Ex deia IIC/IIB T1~T6 Gb Ex tD A21 IP6X T80°C~T440°C	Ex eia IIC/IIB T1~T6 Gb Ex tD A21 IP6X T80°C~T440°C

1) Terminal compartment in type of protection Ex d
2) Terminal compartment in type of protection Ex e

Type (compact/remote; Item No. 13 in type code)

*	Type	Min. ambient temperature $T_{a \min}$
A, P, U	Compact	-20 °C
V, 6		-40 °C
G, N, T, W	Remote	-20 °C
7, 8		-40 °C

Type of cable entry (Item No. 15 in type code)

*	Thread form
A	M20 × 1.5
B	NPT ½"
C	G ½"

Display, operation, power supply (Item No. 16 in type code)

*	Thread form
A, C, E, G, P, R, O, 2, 4, 7	85 – 260 V AC
B, D, F, H, Q, S, 1, 3, 5, 8	20 – 55 V AC/16 – 62 V DC

Outputs/inputs (Item No. 18 in type code)

*	Type of protection
A, B, C, D, J, K, L, M, N, P, Q, V, 2, 4, 5, 7	non Ex ia (intrinsically safe) input /output
F, G, S, T	Ex ia (intrinsically safe) input /output

Note!

A detailed explanation of these values, regarding the available outputs and inputs, as well as a description of the associated terminal assignments and connection data can be found from → 12 onwards.

Temperature table compact versionMax. medium temperature [°C] for T6 ~ T1 in relation to the maximum ambient temperature T_a

	DN	T_a	T6 (85 °C)	T5 (100 °C)	T4 (135 °C)	T3 (200 °C)	T2 (300 °C)	T1 (450 °C)
Promag 5*W**-...	50...2000	+50 °C	80	80	80	80	80	80

	DN	T_a	T6 (85 °C)	T5 (100 °C)	T4 (135 °C)	T3 (200 °C)	T2 (300 °C)	T1 (450 °C)
Promag 5*P**-...	25...200 ¹⁾	+40 °C	80	95	130	150	150	150
	15...600 ²⁾					130	130	130
	25...200 ¹⁾	+45 °C	80	95	130	130	130	130
	15...600 ²⁾							
	25...200 ¹⁾	+50 °C	80	95	95	95	95	95
	15...600 ²⁾							

1) with PFA lining; 2) with PTFE lining

	DN	T_a	T6 (85 °C)	T5 (100 °C)	T4 (135 °C)	T3 (200 °C)	T2 (300 °C)	T1 (450 °C)
Promag 5*H**-...	2...100	+40 °C	80	95	130	150	150	150
		+45 °C	80	95	130	130	130	130
		+50 °C	80	95	95	95	95	95

The minimum ambient temperature is -20 °C.

A version for ambient temperatures up to -40 °C is optionally available

Temperature table remote version**Sensor**Max. medium temperature [°C] for T6 ~ T1 in relation to the maximum ambient temperature T_a

	DN	T_a	T6 (85 °C)	T5 (100 °C)	T4 (135 °C)	T3 (200 °C)	T2 (300 °C)	T1 (450 °C)
Promag 5*W**-...	50...2000	+60 °C	80	80	80	80	80	80

	DN	T_a	T6 (85 °C)	T5 (100 °C)	T4 (135 °C)	T3 (200 °C)	T2 (300 °C)	T1 (450 °C)
Promag 5*P**-...	25...200 ¹⁾	+50 °C	80	95	130	150 ³⁾	150 ³⁾	150 ³⁾
	15...600 ²⁾					130	130	130
	25...200 ¹⁾	+60 °C	80	95	130	130	130	130
	15...600 ²⁾							

1) with PFA lining; 2) with PTFE lining; 3) versions in IP 68 are limited to 130 °C.

	DN	T_a	T6 (85 °C)	T5 (100 °C)	T4 (135 °C)	T3 (200 °C)	T2 (300 °C)	T1 (450 °C)
Promag 5*H**-...	2...100	+50 °C	80	95	130	150	150	150
	2...25	+60 °C	80	95	130	130	130	130
	40...100		80	95	130	150	150	150

The minimum ambient temperature is -20 °C.

A version for ambient temperatures up to -40 °C is optionally available.

TransmitterThe transmitter of the remote version has the temperature class T6 when installing into the Ex d housing up to an ambient temperature of $T_a = 60$ °C.

The maximum ambient temperature range is -20 to +60 °C.

A version for ambient temperatures up to -40 °C is optionally available.

Gas and dust explosion protection

Determine the temperature class for gas in relation to the ambient T_a and medium temperature T_M

Determine the maximum surface temperature for dust in relation to the max. ambient temperature T_a and max. medium temperature T_M

Example

Device: compact version, Promag 53, DN 25, PTFE

Max. ambient temperature: $T_a = 45^\circ\text{C}$

Max. medium temperature: $T_M = 110^\circ\text{C}$

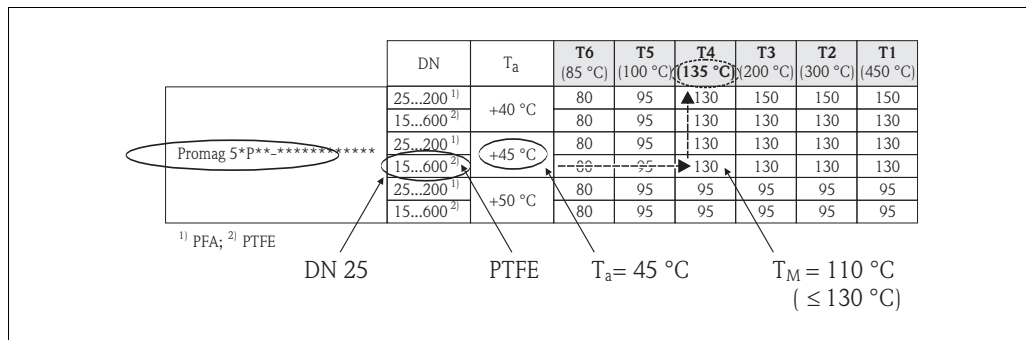

A0005216

Fig. 3: Procedure for calculating the max. surface temperature

1. In the associated temperature table (compact version), the selection of the measuring device (Promag 53P), the nominal diameter (DN 25), the lining material (PTFE) and the ambient temperature T_a (45°C) determine the line in which the max. medium temperature can be found.
2. The fluid temperature T_M (110°C), which is smaller or equal to the max. fluid temperature, determines the column, i.e. the temperature class, for gas ($110^\circ\text{C} \leq 130^\circ\text{C} \rightarrow T_4$).
3. The maximum temperature of the calculated temperature class corresponds to the maximum surface temperature ($T_4 = 135^\circ\text{C} =$ maximum surface temperature for dust).

Design of measuring system

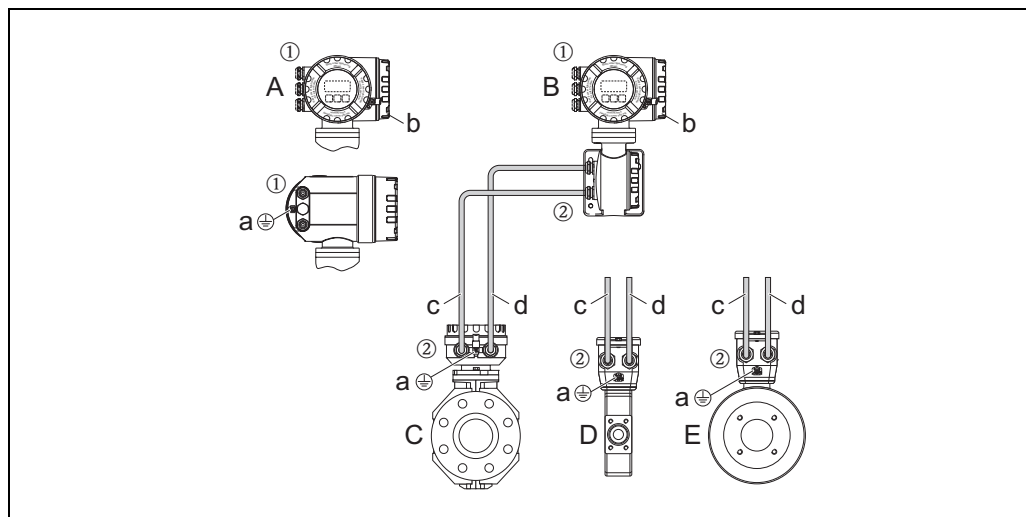

A0005610

Fig. 4: Design of the measuring system, compact/remote version

- A Transmitter housing (compact version)
- B Transmitter housing on connection housing, remote version
- C Sensor connection housing, remote version, Promag W/P
- D Sensor connection housing, remote version, Promag H, DN ≤ 25
- E Sensor connection housing, remote version, Promag H, DN ≥ 40
- a Screw terminal for connecting to the potential equalization
- b Connection compartment cover
- c Connecting cable, coil current cable
- d Connecting cable, signal cable
- ① to ② see following chapter "Cable entries"

Note!

Connection of remote version connecting cable → 11

Cable entries

- ① for connection compartment (Ex d version): power supply cable and cable of the communication circuit → Choice of thread for cable entries M20 × 1.5, ½" NPT or G ½".

Make sure that the Ex d cable glands/entries are secured to prevent working loose and that the seals are installed immediately adjacent to the housing.

- ① for connection compartment (Ex e version): power supply cable and cable of the communication circuit → Choice of cable gland M20 × 1.5 or thread for cable entries ½" NPT or G ½". The cables must be installed such that they are fixed in place. Adequate strain relief must be ensured.
- ② for remote version connecting cable:
→ Choice of cable gland M20 × 1.5 or thread for cable entries ½" NPT or G ½"

⚠ Warning!

The leak-tight of the cable glands and cable entries is to ensure.

Cable specification

You can find information about the cable specification in the associated Operating Instructions.

Potential equalization

- The transmitter (compact and remote version) is to be securely connected to the potential equalization system using the screw terminal on the outside of the transmitter housing. Alternatively, the transmitter of the compact version as of serial number 4Axxxxxx000 can be connected to the potential equalization system via the pipeline if a ground connection via the pipeline according to regulations can be assured.
- When using the remote version, the connection housing of the sensor must be grounded via the external screw terminal. Alternatively, the sensor can be integrated into the potential equalization via the pipeline as long as the pipeline provides a ground connection conforming to regulations.

📎 Note!

Further information about potential equalization, shielding and grounding can be found in the associated Operating Instructions.

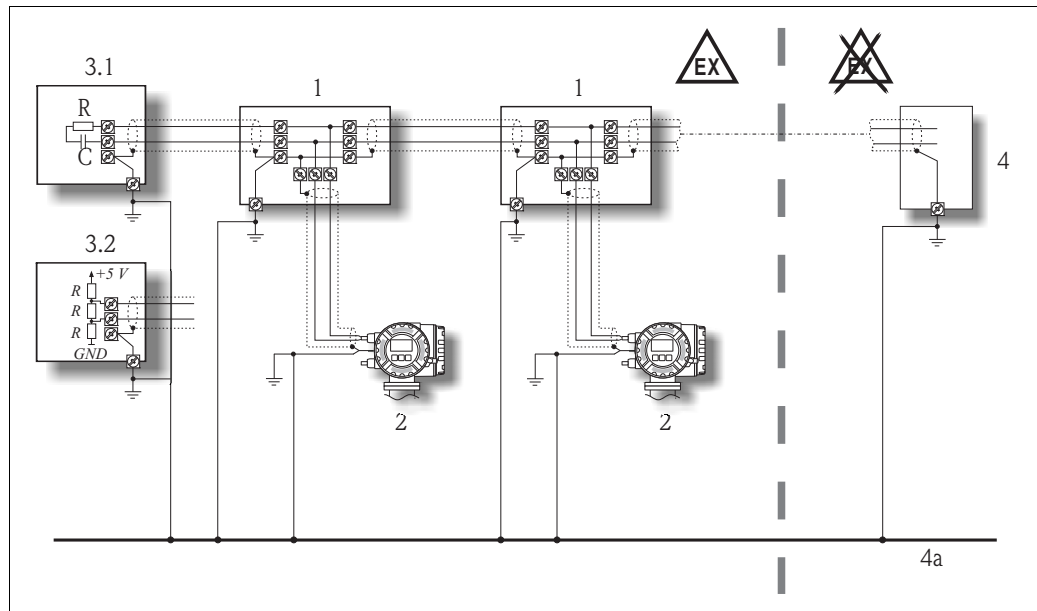
Potential equalization with shield grounded at both sides for fieldbus version

A0005215

Fig. 5: Example for connecting potential equalization lines

- 1 Distributor/T-Box
- 2 Bus devices for potentially explosive atmospheres
- 3.1 Bus terminator PROFIBUS PA and FOUNDATION Fieldbus
- 3.2 Bus terminator PROFIBUS DP and Modbus
- 4 Bus supply unit or automation system
- 4a Potential equalization line is fed out into the safe area

📎 Note!

The length of the spur must be observed.

Connection of remote version connecting cable

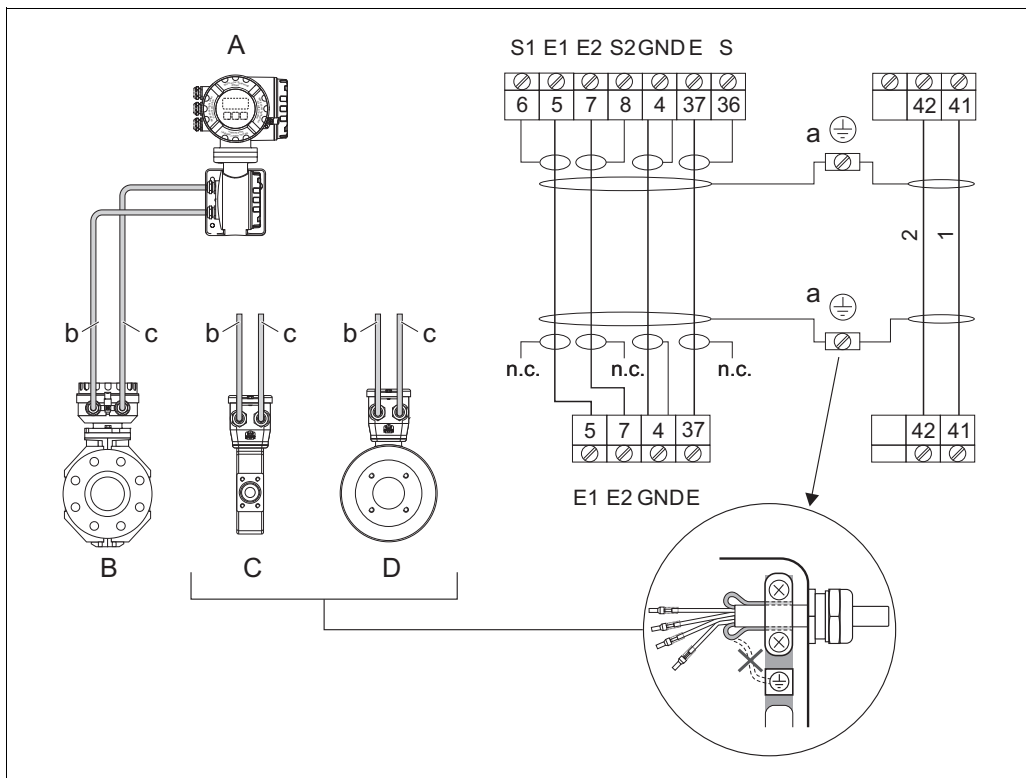

A0005614

Fig. 6: Connection of remote version connecting cable

- A Transmitter housing on connection housing, remote version
- B Sensor connection housing, remote version, Promag W/P
- C Sensor connection housing, remote version, Promag H, DN ≤ 25
- D Sensor connection housing, remote version, Promag H, DN ≥ 40
- a Ground terminals (are provided for connecting a potential equalization connection)
- b Connecting cable, coil circuit
- c Signal circuit connecting cable (electrodes)
- n.c. → not connected, insulated cable screening
- Wire colors → terminal number: 5/6 = brown, 7/8 = white, 4 = green, 37/38 = yellow

Terminal assignment and connection data

Terminal	6 S1	5 E1	7 E2	8 S2	4 GND	37 E	36 S	42 2	41 1
Designation	Measured variable				Pipe	EPD		Coil circuit	
Functional values	Signal circuit							U = 60 V P = 2.5 W	
Electric circuit	[Ex ia] IIC/IIB							Ex e	
U ₀	37 V								
I ₀	25 mA								
P ₀	138 mW								
L ₀	L ₀ IIC = 50 mH / L ₀ IIB = 200 mH								
C ₀	C ₀ IIC = 39 nF / C ₀ IIB = 353 nF								

The connection of the remote version, between sensor and transmitter, is carried out in the explosion protections Ex i (signal circuit) and Ex e (coil circuit).

When using the connecting cable supplied by Endress+Hauser, the intrinsic safety of the circuit is ensured at a maximum cable length of 90 m (for IIC) and 200 m (for IIB).

☞ Caution!

Only preterminated connecting cables supplied by Endress+Hauser must be used.

Electrical connection

Connection compartment

Transmitter housing compact/remote version (terminal assignment, connection data → 9)

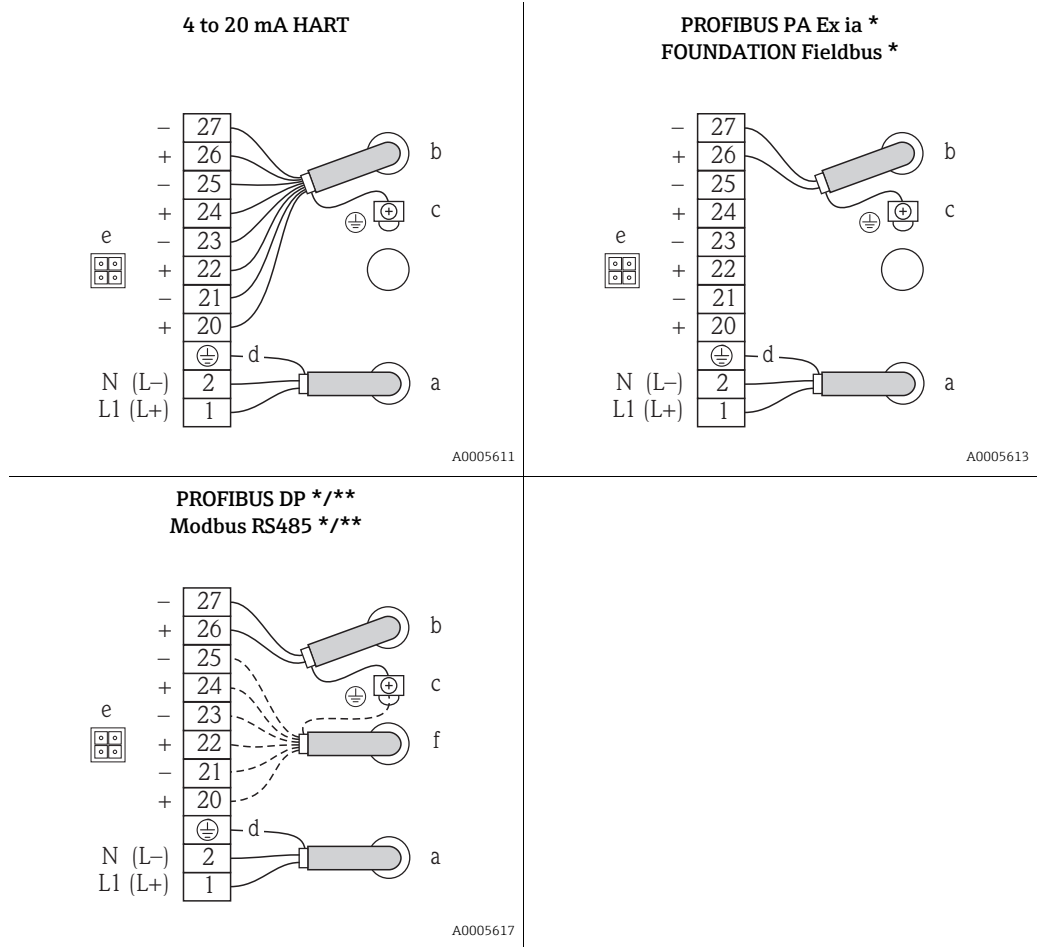

Fig. 7: Electrical connections

*) Fixed communication boards (permanent assignment)

***) Flexible communication boards

a Power supply cable (terminal assignment, connection data → 12)

b Signal cable (terminal assignment, connection data → 13ff.)

c Ground terminal for signal cable shield / fieldbus cable / RS485 line

d Ground terminal for protective ground

e Service adapter for connecting service interface FXA 193 (Fieldcheck, FieldCare)

f Further connections:

- PROFIBUS DP *: Cable for external termination, optional (terminal assignment, connection data → 12)

- PROFIBUS DP **/ Modbus RS485 */**: Signal cable (terminal assignment, connection data → 13)

Terminal assignment and connection data, power supply

Terminal assignment and connection data

All transmitters	1 L (+)	2 N (-)	⊕
Designation	Supply voltage		Protective earth
Functional values	AC: U = 85 to 260 V; AC: U = 20 to 55 V DC: U = 16 to 62 V Power consumption: 15 VA / 15 W		Caution! Observe the grounding plans of the system!
Intrinsically safe circuit	no		
U _m	260 V AC		

Terminal assignment and connection data for signal circuits (intrinsically safe circuits)

 Note!

The following tables contain values/specifications, which are dependent on the type code (type of measuring device). Please compare the following type code to the one shown on the nameplate of your measuring device. A graphic representation of the electrical connections can be found on →  12.

The communication circuits, option F and G, they meet all requirements for a FISCO Field Device (IEC 60079-27).

Terminal assignment of transmitter 53*-*****F+##**#**

Transmitter	Terminal no. (inputs/outputs)							
	20 (+)	21 (-)	22 (+)	23 (-)	24 (+)	25 (-)	26 (+)	27 (-)
Assignment	-	-	-	-	-	-	PROFIBUS PA passive PA + PA -	
Electric circuit	-	-	-	-	-	-	Ex ia	
Safety-related values	-	-	-	-	-	-	U _i	30 V DC
							I _i	600 mA
							P _i	8.5 W
							L _i	≤ 10 μH
							C _i	≤ 5 nF
							FISCO	Field device
Functional values	-	-	-	-	-	-	galvanically isolated, U _{Bus} 9 to 32 V DC I _{Bus} 11 mA IEC 61158-2 (MBP)	

Terminal assignment of transmitter 53*-*****G+##**#**

Transmitter	Terminal no. (inputs/outputs)							
	20 (+)	21 (-)	22 (+)	23 (-)	24 (+)	25 (-)	26 (+)	27 (-)
Assignment	-	-	-	-	-	-	FOUNDATION Fieldbus passive FF + FF -	
Electric circuit	-	-	-	-	-	-	Ex ia	
Safety-related values	-	-	-	-	-	-	U _i	30 V DC
							I _i	600 mA
							P _i	8.5 W
							L _i	≤ 10 μH
							C _i	≤ 5 nF
							FISCO	Field device
Functional values	-	-	-	-	-	-	galvanically isolated, U _{Bus} 9 to 32 V DC I _{Bus} 12 mA IEC 61158-2 (MBP)	

Terminal assignment of transmitter 53***-*****S+##**#

Transmitter	Terminal no. (inputs/outputs)							
	20 (+)	21 (-)	22 (+)	23 (-)	24 (+)	25 (-)	26 (+)	27 (-)
Assignment	-		-		Pulse/frequency output, passive		Current output HART, active	
Electric circuit	-		-		Ex ia		Ex ia	
Safety-related values	-		-		U _i	30 V DC	U _o	21.8 V DC
					I _i	500 mA	I _o	90 mA
					P _i	600 mW	P _o	491 mW
					L _i	negligible	L _o IIC/IIB	4.1 mH/15 mH
					C _i	6 nF	C _o IIC/IIB	160 nF/1160 nF
							¹⁾ L _o IIC/IIB	2 mH/10 mH
							¹⁾ C _o IIC/IIB	80 nF/300 nF
							U _i	30 V DC ²⁾
							I _i	10 mA ²⁾
							P _i	0.3 W ²⁾
							L _i	negligible
							C _i	6 nF
Functional values	-		-		galvanically isolated, passive: 30 V DC / 250 mA Open Collector Full scale frequency 2 to 5000 Hz		galvanically isolated, active: 0/4 to 20 mA R _L < 400 Ω R _L HART ≥ 250 Ω	
¹⁾ Permitted values in the event of simultaneous occurrence of concentrated inductances and capacitances.								
²⁾ The interconnection must be assessed according to the valid construction provisions.								

Terminal assignment of transmitter 53***-*****T+##**#

Transmitter	Terminal no. (inputs/outputs)							
	20 (+)	21 (-)	22 (+)	23 (-)	24 (+)	25 (-)	26 (+)	27 (-)
Assignment	-		-		Pulse/frequency output, passive		Current output HART, passive	
Electric circuit	-		-		Ex ia		Ex ia	
Safety-related values	-		-		U _i	30 V DC	U _i	30 V DC
					I _i	500 mA	I _i	100 mA
					P _i	600 mW	P _i	1.25 W
					L _i	negligible	L _i	negligible
					C _i	6 nF	C _i	6 nF
Functional values	-		-		galvanically isolated, passive: 30 V DC / 250 mA Open Collector Full scale frequency 2 to 5000 Hz		galvanically isolated, passive: 4 to 20 mA voltage drop ≤ 9 V R _L < [(V _{p. supply} - 9 V) ÷ 25 mA]	

Terminal assignment and connection data for signal circuits (non-intrinsically safe circuits)

 **Note!**

The following tables contain values/specifications, which are dependent on the type code (type of measuring device). Please compare the following type code to the one shown on the nameplate of your measuring device. A graphic representation of the electrical connections can be found on →  12.

Terminal assignment

Transmitter	Terminal no. (inputs/outputs)							
	20 (+)	21 (-)	22 (+)	23 (-)	24 (+)	25 (-)	26 (+)	27 (-)
<i>Non-convertible communication boards (fixed assignment)</i>								
53***-...*A	-	-	-	-	Pulse/frequency output		Current output HART	
53***-...*B	Relay output 2		Relay output 1		Pulse/frequency output		Current output HART	
53***-...*J	-	-	-	-	External termination +5 V DGND		PROFIBUS DP * B A	
53***-...*K	-	-	-	-	-		FOUNDATION Fieldbus FF + FF -	
53***-...*Q	-	-	-	-	Status input		Modbus RS485 * B A	
<i>Convertible communication boards</i>								
53***-...*C	Relay output 2		Relay output 1		Pulse/frequency output		Current output HART	
53***-...*D	Status input		Relay output		Pulse/frequency output		Current output HART	
53***-...*L	Status input		Relay output 2		Relay output 1		Current output HART	
53***-...*M	Status input		Pulse/frequency output		Pulse/frequency output		Current output HART	
53***-...*N	Current output		Pulse/frequency output		Status input		Modbus RS485 * B A	
53***-...*P	Current output		Pulse/frequency output		Status input		PROFIBUS DP * B A	
53***-...*V	Relay output 2		Relay output 1		Status input		PROFIBUS DP * B A	
53***-...*2	Relay output		Current output		Pulse/frequency output		Current output HART	
53***-...*4	Current input		Relay output		Pulse/frequency output		Current output HART	
53***-...*5	Status input		Current input		Pulse/frequency output		Current output HART	
53***-...*7	Relay output 2		Relay output 1		Status input		Modbus RS485 * B A	
<i>Safety-related and functional values of signal circuits →  16</i>								
* PROFIBUS DP, Modbus RS485: - terminal 26 (+) → B (Rx/D/TxD-P) - terminal 27 (-) → A (Rx/D/TxD-N)								

Safety-related and functional values of signal circuits

Signal circuits	Functional values	Safety-related values
Current output HART	galvanically isolated, active/passive can be selected: <ul style="list-style-type: none"> ▪ active: 0/4 to 20 mA $R_L < 700 \Omega$, $R_L \text{ HART} \geq 250 \Omega$ ▪ passive: 4 to 20 mA $V_s = 18$ to 30 V DC, $R_i \geq 150 \Omega$ 	intrinsically safe = no $U_m = 260 \text{ V}$ $I_m = 500 \text{ mA}$
Current output	galvanically isolated, active/passive can be selected: <ul style="list-style-type: none"> ▪ active: 0/4 to 20 mA $R_L < 700 \Omega$ ▪ passive: 4 to 20 mA $V_s = 18$ to 30 V DC, $R_i \geq 150 \Omega$ 	
Pulse/frequency output	galvanically isolated, active/passive can be selected: <ul style="list-style-type: none"> ▪ active: 24 V DC / 25 mA (max. 250 mA during 20 ms) $R_L > 100 \Omega$ ▪ passive: 30 V DC / 250 mA Open Collector Full scale frequency 2 to 10000 Hz ($f_{\max} = 12500 \text{ Hz}$)	
Status output	galvanically isolated, Open Collector max. 30 V AC / 250 mA	
Relay output	galvanically isolated, max. 30 V AC / 500 mA max. 60 V DC / 100 mA	
Current input	galvanically isolated, active/passive can be selected: <ul style="list-style-type: none"> ▪ active: 4 to 20 mA $R_i \leq 150 \Omega$ $U_{\text{out}} = 24 \text{ V DC}$, short-circuit proof ▪ passive: 0/4 to 20 mA $R_i < 150 \Omega$ $U_{\max} = 30 \text{ V DC}$ 	
Status input (53***-*...*D, L, M)	galvanically isolated, 3 to 30 V DC $R_i = 5 \text{ k}\Omega$	
Status input (53***-*...*N, P, Q, V, 7)	galvanically isolated, Independent of polarity, 3 to 30 V DC $R_i = 3 \text{ k}\Omega$	
PROFIBUS DP	galvanically isolated, RS485 as per Standard EIA/TIA-485	
FOUNDATION Fieldbus	galvanically isolated, $U_{\text{BUS}} = 9$ to 32 V DC $I_{\text{BUS}} = 12 \text{ mA}$ IEC 61158-2 (MBP)	
Modbus RS485	galvanically isolated, RS485 as per Standard EIA/TIA-485	

Service adapter

The service adapter is only used for connecting service interfaces approved by Endress+Hauser.

⚠ Warning!

It is not permissible to connect the service adapter whilst the atmosphere is considered to be explosive.

Device fuse

⚠ Warning!

Use only fuses of the following types; the fuses are installed on the power supply board:

- Voltage 20 to 55 V AC / 16 to 62 V DC:
fuse 2.0 A slow-blow, disconnect capacity 1500 A
(Schurter, 0001.2503 or Wickmann, Standard Type 181 2.0 A)
- Voltage 85 to 260 V AC:
fuse 0.8 A slow-blow, disconnect capacity 1500 A
(Schurter, 0001.2507 or Wickmann, Standard Type 181 0.8 A)

Technical Data**Dimensions**

Please refer to the respective Technical Information for these dimensions:

- Promag 50W, 53W → TI00046D
- Promag 50P, 53P → TI00047D
- Promag 50H, 53H → TI00048D

Weight

The weight of the Ex d version is approx. 2 kg greater than that of the standard version.

www.addresses.endress.com
