

Special Documentation

Micropilot FMR5x

Heartbeat Diagnostics
Heartbeat Verification
Heartbeat Monitoring

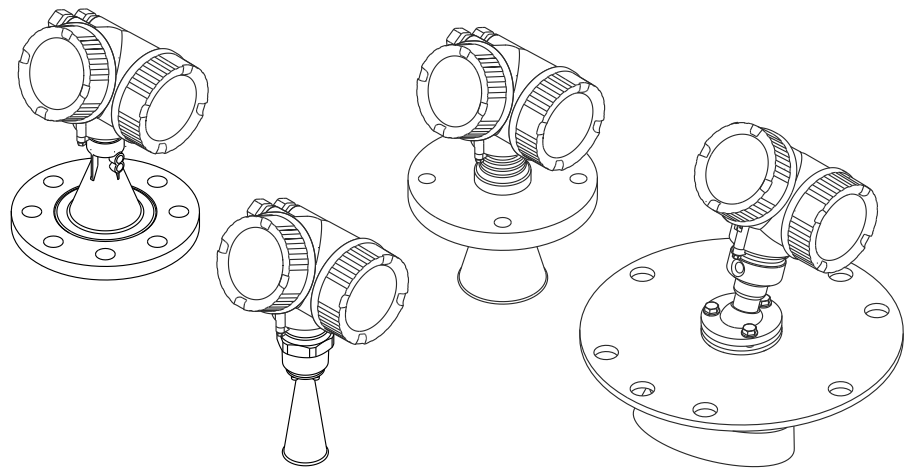

Table of contents

1	Document information	4
1.1	Document function	4
1.2	Symbols used	4
1.3	Documentation	5
2	Heartbeat modules	6
2.1	Overview	6
2.2	Short description of the modules	6
2.3	Module availability	9
2.4	Subsequent activation of the modules	9
3	Heartbeat Diagnostics	10
3.1	Diagnostic messages on the local display module (example)	10
3.2	Diagnotic messages in an operating tool	11
4	Heartbeat Verification	12
4.1	Verification report	12
4.2	Proof test for SIL or WHG applications	16
5	Heartbeat Monitoring	18
5.1	Monitoring parameters in the verification report	18
5.2	Foam detection	23
5.3	Buildup detection	26

1 Document information

1.1 Document function

This Special Documentation contains a description of the additional parameters and technical data that are available with the **Heartbeat Verification** and **Heartbeat Monitoring** application packages.

 This manual is a Special Documentation. It is not a substitute for the technical documentation according to the following table:





Product	Communication	Operating Instructions	Technical Information
FMR50	HART	BA01045F	TI01039F
	PROFIBUS PA	BA01124F	
	FOUNDATION Fieldbus	BA01120F	
<ul style="list-style-type: none"> ▪ FMR51 ▪ FMR52 	HART	BA01049F	TI01040F
	PROFIBUS PA	BA01125F	
	FOUNDATION Fieldbus	BA01121F	
<ul style="list-style-type: none"> ▪ FMR53 ▪ FMR54 	HART	BA01050F	TI01041F
	PROFIBUS PA	BA01126F	
	FOUNDATION Fieldbus	BA01122F	
<ul style="list-style-type: none"> ▪ FMR56 ▪ FMR57 	HART	BA01048F	TI01042F
	PROFIBUS PA	BA01127F	
	FOUNDATION Fieldbus	BA01123F	



 The Operating Instructions and other technical documents pertaining to the device are available via:

- Internet: www.endress.com/deviceviewer
- Smart phone/tablet: *Endress+Hauser Operations App*

1.2 Symbols used

1.2.1 Symbols for certain types of information

Symbol	Meaning
 A0011193	Tip Indicates additional information.
 A0011194	Reference to documentation Refers to the corresponding device documentation.
 A0011195	Reference to page Refers to the corresponding page number.
 A0011196	Reference to graphic Refers to the corresponding graphic number and page number.
 A0013140	Operation via local display Indicates navigation to the parameter via the local display.

Symbol	Meaning
 A0013143	Operation via operating tool Indicates navigation to the parameter via the operating tool.
 A0013144	Write-protected parameter Indicates a parameter that can be locked against changes by entering a user-specific code.

1.2.2 Symbols in graphics

Symbol	Meaning
1, 2, 3 ...	Item numbers
A, B, C, ...	Views
A-A, B-B, C-C, ...	Sections

1.3 Documentation

-  For an overview of the scope of the associated Technical Documentation, refer to the following:
- The *W@M Device Viewer*: enter the serial number from the nameplate (www.endress.com/deviceviewer)
 - The *Endress+Hauser Operations App*: Enter the serial number from the nameplate or scan the 2-D matrix code (QR code) on the nameplate.

2 Heartbeat modules

2.1 Overview

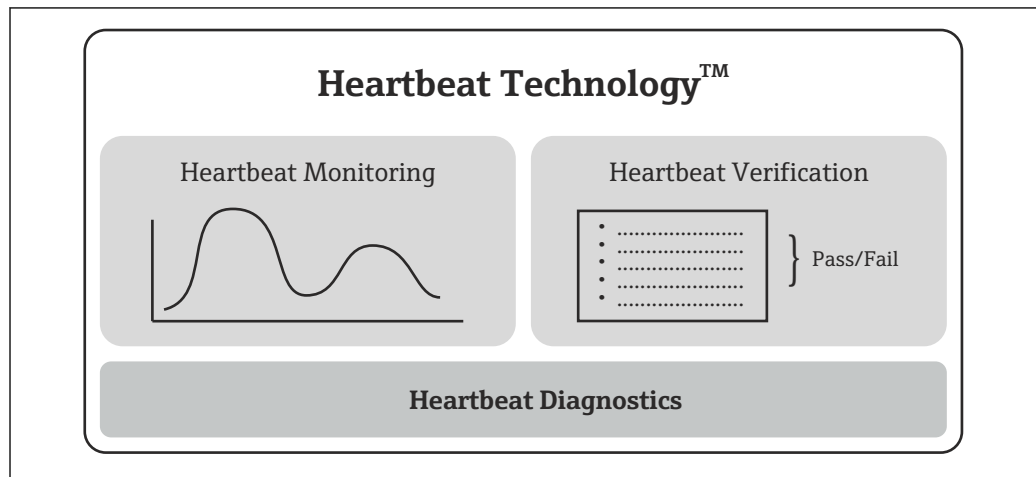

1 Heartbeat modules

2.2 Short description of the modules

2.2.1 Heartbeat Diagnostics

Function

- Continuous self-monitoring of the device.
- Diagnostic messages output to
 - the local display
 - an asset management system (e.g. FieldCare/DeviceCare)
 - an automation system (e.g. PLC)

Advantages

- Device condition information is available immediately and processed in time.
- The status signals are classified in accordance with VDI/VDE 2650 and NAMUR recommendation NE 107 and contain information about the cause of the error and remedial action.

Detailed description

→ 10

2.2.2 Heartbeat Verification

Device functionality checked on demand

- Verification of the correct functioning of the measuring device within specifications (see Technical Information of the respective device, →  4).
- The verification result provides information about the condition of the device: **Passed** or **Failed**.
- The results are documented in a verification report.
- The automatically generated report supports the obligation to demonstrate compliance with internal and external regulations, laws and standards.
- Verification is possible without interrupting the process.

Advantages

- No onsite presence is required to use the function.
- The DTM ¹⁾ triggers verification in the device and interprets the results. No specific knowledge is required on the part of the user.
- The verification report can be used to prove quality measures to a third party.
- **Heartbeat Verification** can replace other maintenance tasks (e.g. periodic check) or extend the test intervals.

Proof test for SIL/WHG-locked devices ²⁾

- The **Heartbeat Verification** module contains a wizard for the proof test which must be performed at appropriate intervals for the following applications:
 - SIL (IEC61508/IEC61511)
 - WHG (German Water Resources Act)
- When a proof test is performed, the SIL-locking or WHG-locking will be temporarily unlocked. After the proof test, the wizard guides back to the locked state.
- The wizard can be used via FieldCare, DeviceCare, PACTware or a DTM-based process control system.

 In the case of SIL-locked and WHG-locked devices, the "Heartbeat Verification" module can **not** be used without additional measures (e.g. by-passing of the output current) because the output current must be simulated (Increased safety mode) or the level must be approached manually (Expert mode) during subsequent re-locking (SIL/WHG locking).

Detailed description

→  12

1) DTM: Device Type Manager; controls device operation via DeviceCare, FieldCare, PACTware or a DTM-based process control system.

2) Only relevant for devices with SIL or WHG approval: order code 590 ("Additional approval"), option LA ("SIL") or LC ("WHG").

2.2.3 Heartbeat Monitoring

Monitoring parameters in the verification report

- For the test items of the verification report, the corresponding parameter values are also included in the report.
- The verification report contains additional parameter values to assess the condition of the device.
- The data are supplied in the XML format in order to allow easy trend analysis in an external tool.

Advantages

- Early detection of changes (trends) to ensure plant availability and product quality.
- Use of device data for the proactive planning of measures (e.g. cleaning/maintenance).
- Identification of undesirable process conditions as the basis to optimizing the facility and the processes.
- Can be used to control automated measures to remove foam or buildup.

"Foam detection" wizard

 The **Foam detection** wizard is only visible for **Medium type = Liquid**. This is the case for FMR50, FMR51, FMR52, FMR53 and FMR54.

- The Heartbeat Monitoring module contains the **Foam detection** wizard.
- This wizard is used to configure automatic foam detection, which detects foam on the product surface on the basis of the reduced signal amplitude. Foam detection can be linked to a switch output in order to control a sprinkler system, for example, which dissolves the foam.
- This wizard can be used via FieldCare, DeviceCare, PACTware or a DTM-based process control system.

"Build-up detection" wizard

- The Heartbeat Monitoring module contains the **Build-up detection** wizard.
- The wizard is used to configure automatic buildup detection, which detects the buildup of deposits on the antenna on the basis of the increased area of the coupling signal. Buildup detection can be linked to a switch output in order to control a compressed air system, for example, to clean the antenna.
- This wizard can be used via FieldCare, DeviceCare, PACTware or a DTM-based process control system.

 The **Foam detection** and **Build-up detection** wizards cannot be used together.

Detailed description

→  18

2.3 Module availability

Heartbeat Diagnostics is available in all device versions with Heartbeat Technology. Feature 540 in the product structure determines whether **Heartbeat Verification** and **Heartbeat Monitoring** are available:

Heartbeat module	Feature 540: "Application package"
Heartbeat Verification	<ul style="list-style-type: none"> ▪ EH: "Heartbeat Verification + Monitoring" ▪ EJ: "Heartbeat Verification"
Heartbeat Monitoring	EH: "Heartbeat Verification + Monitoring"

If the device was ordered with one of these options, the corresponding Heartbeat modules are available on delivery.

2.4 Subsequent activation of the modules

If a Heartbeat module was not selected when the device was ordered, it is possible to activate the module subsequently depending on the firmware version. Contact your Endress+Hauser sales organization and you will get a serial-number-specific activation code that must be entered via the operating menu. The relevant Heartbeat module is then permanently available in the device.

2.4.1 Menu path for the activation code

Navigation

"Expert" → System → Administration → Activate SW option

2.4.2 Firmware versions that support subsequent module activation

Device	Communication	Firmware version
FMR5x	HART	01.02.01 or higher
	PROFIBUS PA	01.01.01 or higher
	FOUNDATION Fieldbus	01.01.01 or higher

3 Heartbeat Diagnostics

Device diagnostic messages, along with remedial measures, are displayed:

- on the local display of the device
- in the operating tool (FieldCare/DeviceCare)

i For information about using the diagnostic messages, see the "Diagnostics and troubleshooting" section of the Operating Instructions.

Operating Instructions: → 4

3.1 Diagnostic messages on the local display module (example)

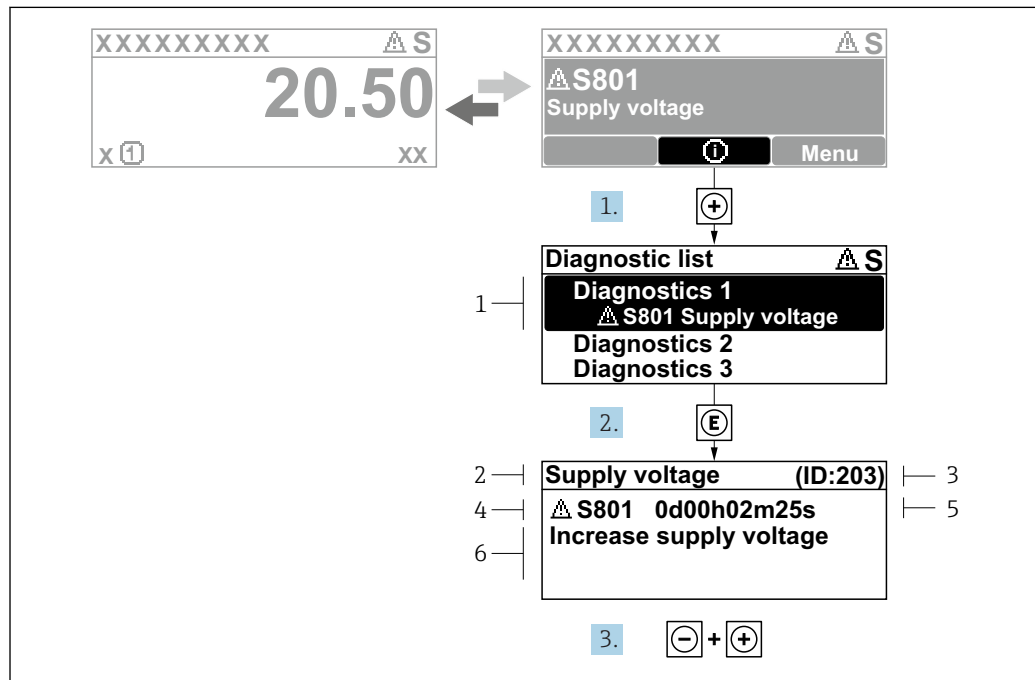

A0029431-EN

2 Message for remedial measures

- 1 Diagnostic information
- 2 Short text
- 3 Service ID
- 4 Diagnostic behavior with diagnostic code
- 5 Operation time of occurrence
- 6 Remedial measures

3.2 Diagnostic messages in an operating tool

1. Navigate to the **Diagnostics** menu.
 - ↳ In the **Actual diagnostics** parameter, the diagnostic event is shown with event text.
2. On the right in the display range, hover the cursor over the **Actual diagnostics** parameter.

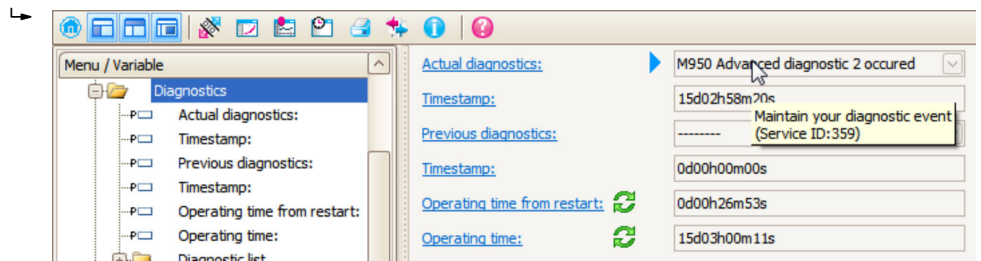

A tool tip with remedial measures for the diagnostic event appears.

4 Heartbeat Verification

4.1 Verification report

4.1.1 Creating the verification report using the wizard

i The wizard to create a verification report is only available if the device is operated via FieldCare, DeviceCare, PACTware or a DTM-based process control system.

1.

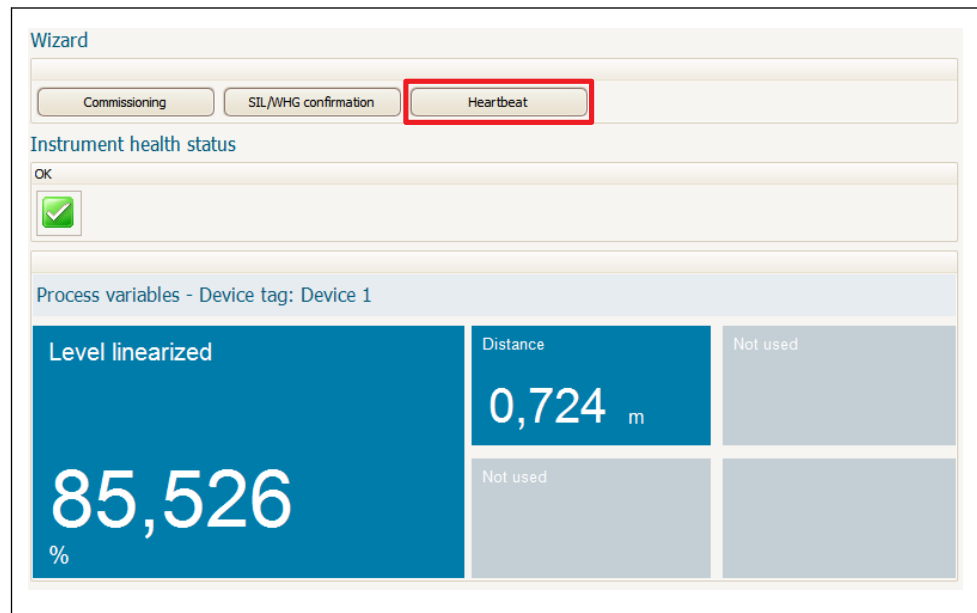

A0032409

Click the **Heartbeat** button on the dashboard.

↳ A choice of heartbeat wizards is displayed.

2.

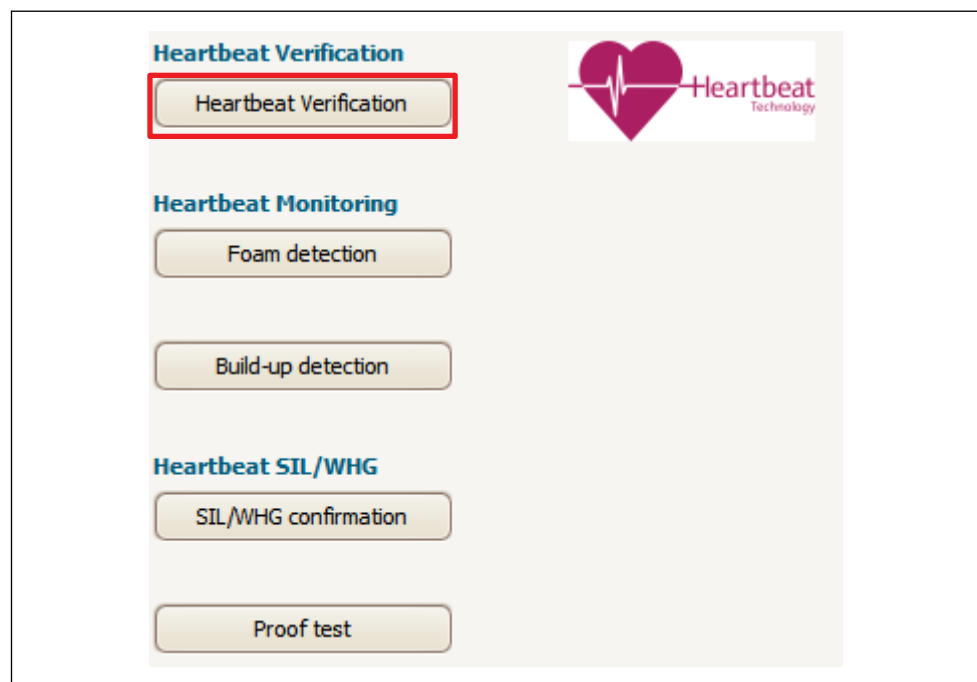

A0032551

Select the **Heartbeat Verification** wizard.

3.

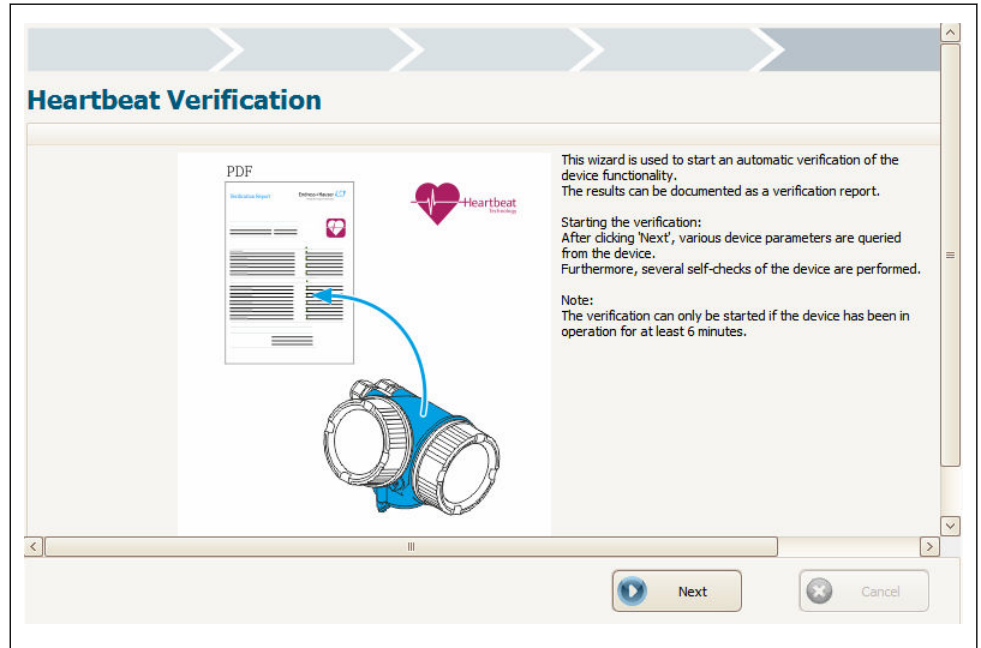



Follow the instructions given by the wizard.

- ↳ The wizard guides you through the entire process for creating the verification report. The verification report can be saved as a PDF or XML file.

4.1.2 Contents of the verification report



- The verification report contains the results of the test items: **Passed** or **Failed** is indicated as the result.
- If the **Heartbeat Monitoring** module is available, additional pages with the test items and associated parameter values are displayed in addition to the verification report.

Verification report: general information

Parameter	Description/comments
Device information	
Location	Location of the device within the plant; is defined when the verification report is created.
Device tag	Is defined when commissioning the device: Commissioning → Device tag
Device name (HART, PROFIBUS)	Is hard-programmed into the device.
Device Type (FOUNDATION Fieldbus)	Is hard-programmed into the device.
Serial number	Is hard-programmed into the device.
Firmware version	Is hard-programmed into the device.
ENP version (FOUNDATION Fieldbus)	Is hard-programmed into the device.
Order code (FOUNDATION Fieldbus)	Is hard-programmed into the device.
<ul style="list-style-type: none"> ■ Extended order code 1 to 3 (HART, PROFIBUS) ■ Extended order code 1 to 2 (FOUNDATION Fieldbus) 	Contains the options of all the ordering features of the device. Is hard-programmed into the device.
Verification information	
Date/time	Date and time when the verification was performed.
Notes	Notes that can be entered when creating the verification report.
Result	
Overall verification result*	<ul style="list-style-type: none"> ■ : Passed ■ : Failed

Verification report: verification results



The test result for all the test items is given on the subsequent pages. The following results are possible:

- : Passed
- : Failed

Verification criteria for the test items

Test item	Verification criterion
Mainboard module	
Check set and measured current	Indicates whether read-back current at the output matches the current set by the device.
Logical program run control	Indicates whether the function blocks of the software are executed in the correct order.
Check sum RAM	Checks the correct function of the RAM (Random Access Memory).
Status	Checks all the relevant status signals of the device.
I/O module	
Check sum RAM	Checks the correct function of the RAM (Random Access Memory).
Sensor	
Result self check	Checks whether the device is fit for use. To do so, a test signal generated in the sensor module is fed into the analog path. The test signal is recorded and evaluated. Test: <ul style="list-style-type: none"> ■ Test echo in timeframe? ■ Test echo amplitude in permitted range?
Result device check	Checks the strength of the found echos.
Reference pulse HF	Checks the sensor functionality and the functionality of the signal path in the sensor module.
Quartz synchronisation	Checks the basic functions that are necessary to achieve the required accuracy.
Check sum RAM	Checks the correct function of the RAM (Random Access Memory).
Sensor module voltage verification	Checks the voltage of the sensor module.
Temperature check	Checks whether the temperature in the terminal compartment is within the critical limits.

Monitoring parameters in the verification report

 In the case of devices with the "Heartbeat Monitoring" module, the verification report contains additional monitoring parameters →  18.

4.2 Proof test for SIL or WHG applications

1.

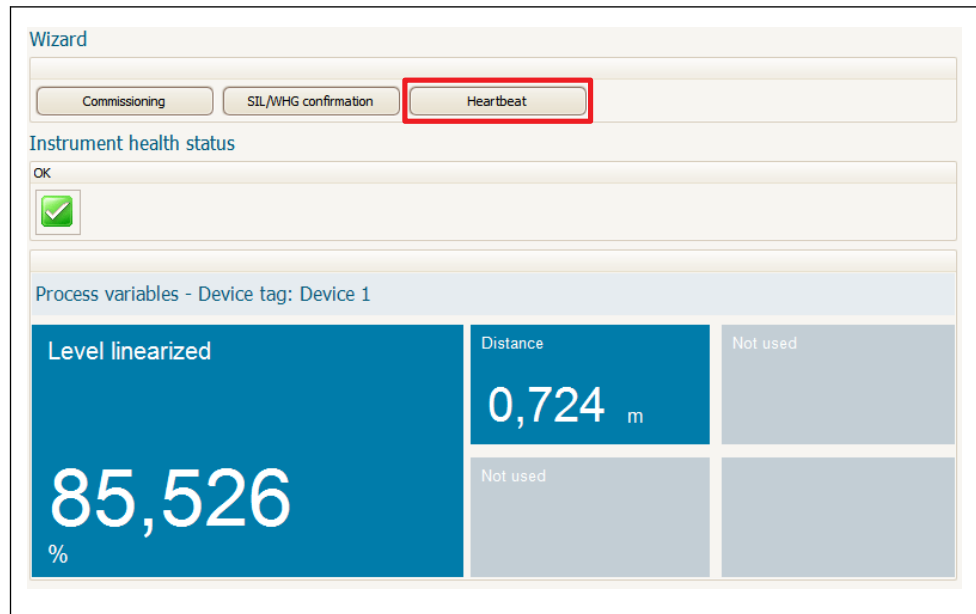

A0032409

Click the **Heartbeat** button on the dashboard.

↳ A choice of heartbeat wizards is displayed.

2.

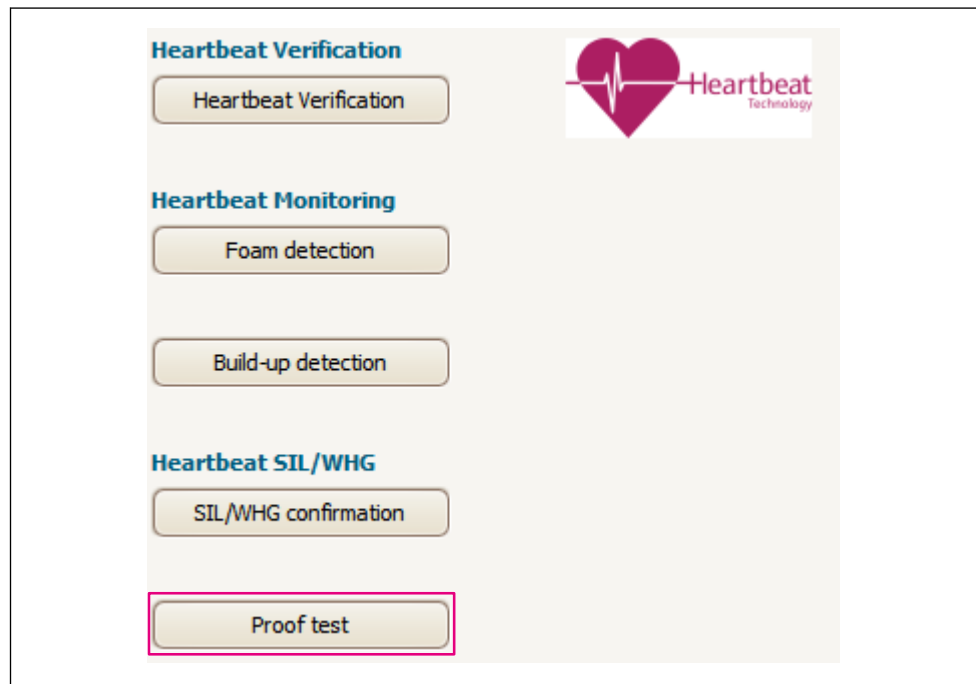

A0032552

Select the **Proof test** wizard.

3.

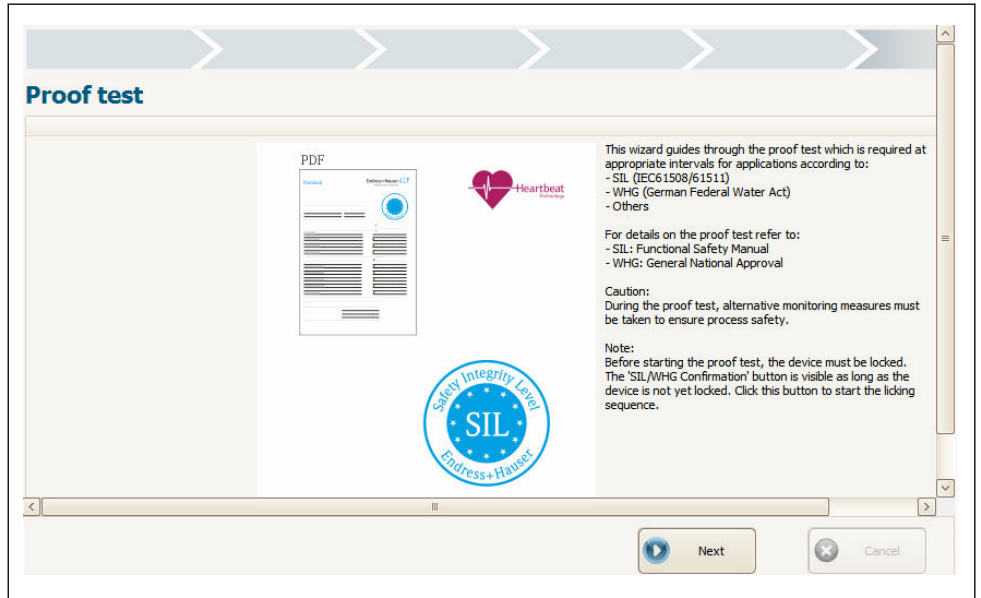

A0032410

Click **"Next"** to start the wizard.

4.

The **Configuration counter** parameter is displayed (among other things) on the next page.

Compare the displayed value to the value from the last proof test protocol:

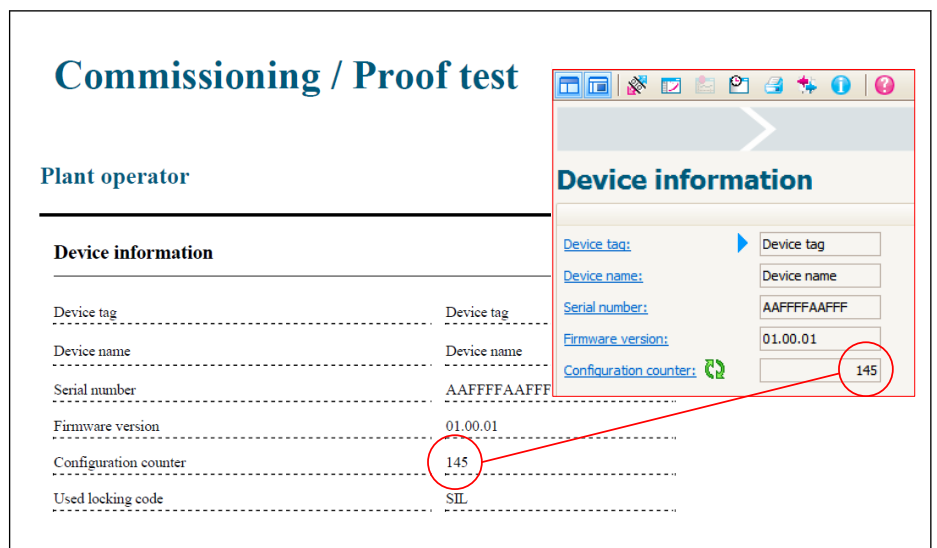

A0034502

If the values are identical, the device configuration has not been changed since the last proof test.

5.

On the next pages follow the instructions of the wizard.





The wizard guides through the complete proof test. Before completing the wizard, a proof test protocol can be saved as a PDF file.

5 Heartbeat Monitoring

5.1 Monitoring parameters in the verification report

In the case of devices with the "Heartbeat Monitoring" module, the verification report contains two additional tables with detailed information on the monitoring parameters.



- Table "Monitoring parameters of the test items" (→  18)
- Table "Additional monitoring parameters" (→  20)

The following is specified for each monitoring parameter:

- the parameter name
- the unit (if relevant for this parameter)
- the measured value
- the minimum permitted value (if relevant for this parameter)
- the maximum permitted value (if relevant for this parameter)

5.1.1 Monitoring parameters of the test items

The monitoring parameters of the test items enable device experts to analyze the device status in detail.

Test item	Monitoring parameter	Meaning/remarks
Mainboard module		
Check set and measured current	-	Indicates whether read-back current at the output matches the current set by the device.
Logical program run control	-	Indicates whether the function blocks of the software are executed in the correct order.
Check sum RAM	-	Checks the correct function of the RAM (Random Access Memory).
Status	Diagnostics 1	Up to five diagnostic messages are displayed. <ul style="list-style-type: none"> ▪ Calling up additional information, including remedy measures: →  10 ▪ Additional information on diagnostic messages: Operating Instructions (BA) of the device (→  4), chapter "Diagnostics and troubleshooting"
	Diagnostics 2	
	Diagnostics 3	
	Diagnostics 4	
	Diagnostics 5	
I/O module		
Check sum RAM	-	Checks the correct function of the RAM (Random Access Memory).
Sensor		
Result self check	Result self check	Checks whether the device is fit for use. To do so, a test signal generated in the sensor module is fed into the analog path. The test signal is recorded and evaluated. Test: <ul style="list-style-type: none"> ▪ Test echo in timeframe? ▪ Test echo amplitude in permitted range?
	Analogpath test amplitude	
	Analogpath test noise amplitude	
	Analogpath test reference amplitude	
	Difference to reference amplitude	

Test item	Monitoring parameter	Meaning/remarks
Result device check	Result device check	The Result device check monitoring parameter checks the strength of the found echos.
	Level signal	Possible results:
	Near distance	<ul style="list-style-type: none"> ■ Installation ok ■ Accuracy reduced (signal available but its strength near the lower limit) ■ Measurement capability reduced (signal too weak) ■ Check not done
	Last check time	The additional monitoring parameters indicate possible causes for a weak signal and thus help to optimize the installation and calibration of the device.
Reference pulse HF	Reference echo amplitude	Checks the sensor functionality and the functionality of the signal path in the sensor module.
Quartz synchronisation	Request cycle time	Checks the synchronization of the HF signals and thus the built-in quartz crystals and oscillators.
	Sweep time	
	Unfiltered sweep time	
Check sum RAM	-	Checks the correct function of the RAM (Random Access Memory).
Sensor module voltage verification	-	Checks the voltage of the sensor module.
Temperature check (FOUNDATION Fieldbus)		Checks whether the temperature in the terminal compartment is within the critical limits. Temperatures outside the critical limits may cause interruptions of the measurement.
Temperature check (HART, PROFIBUS PA)	Electronic temperature	Checks whether the temperature in the terminal compartment is within the critical limits. Temperatures outside the critical limits may cause interruptions of the measurement.
	Max. electronics temperature	→  22
	Min. electronics temperature	



5.1.2 Additional monitoring parameters

Trend evaluation

The additional monitoring parameters convey especially useful information when taking into account not only their current value but also their development (trend) in the past. The XML format of the verification report is particularly suited for the trend evaluation in an external tool.

Monitoring parameter	Meaning/Remarks
<ul style="list-style-type: none"> ■ Min. terminal voltage ■ Max. terminal voltage (HART, PROFIBUS PA)	<p>Meaning Minimum or maximum voltage at the supply terminals in the past</p> <p>Evaluation Used to detect possible voltage spikes.</p>
Terminal voltage 1 (HART, PROFIBUS PA)	<p>Meaning Voltage at the supply terminals</p> <p>Evaluation</p> <ul style="list-style-type: none"> ■ Voltages exceeding the maximum limit may damage the device. ■ Voltages which are permanently near the upper limit may reduce the life expectancy of the device. ■ If the voltage falls below the lower limit, the device may fail. <p>Evaluation of the trend Decreasing terminal voltages may indicate corrosion of the supply terminals.</p>
Relative echo amplitude	<p>Meaning Distance of the amplitude of the level signal above the evaluation curve (dependent on the noise level). This value is dependent on the level distance and a number of process conditions.</p> <p>Evaluation of the trend Significant decreases of the amplitude while the other conditions (distance, medium, status of process) remain the same, may indicate build-up at the antenna.</p>
Absolute echo amplitude	<p>Meaning Absolute amplitude of the level signal (not taking into account the noise level). This value is dependent on the level distance and a number of process conditions.</p> <p>Evaluation of the trend Significant decreases of the amplitude while the other conditions (distance, medium, status of process) remain the same, may indicate build-up at the antenna.</p>
Tank bottom echo amplitude	<p>Meaning Amplitude of the tank bottom signal</p> <p>Evaluation of the trend Significant decreases of the amplitude while the other conditions (distance, medium, status of process) remain the same, may indicate build-up at the antenna.</p>
Area of incoupling	<p>Meaning Integral of the envelope curve in the range 0 to 1 m (0 to 3.3 ft)</p> <p>Evaluation of the trend An increase of this value hints at clogging of the antenna.</p>

Monitoring parameter	Meaning/Remarks
Last level changed (HART, PROFIBUS PA)	<p>Meaning Lists the tracking history of the level signal. This eight-digit shift register is updated every time the tracking of the echo has been interrupted. The newest value is at the right.</p> <p>Meaning of the numbers:</p> <ul style="list-style-type: none"> ■ 1: The echo is determined by static algorithms. This corresponds to a stable evaluation and tracking of the echo. ■ 2: The tracked echo has been lost. Frequent occurrence of 2 hints at an instable echo. ■ 3: The evaluated echo has jumped from a static to a moving echo. Most likely the previous echo was a static interference signal. ■ 4: (only for Evaluation mode = Long time history) A plausibility check using the end-of-probe or tank bottom signal has caused an echo jump. ■ 5: (only for Evaluation mode = Long time history) A plausibility check using a multiple echo has caused an echo jump. ■ 6: (only for Evaluation mode = Long time history) The evaluation of the echo track has caused the evaluation of a different echo. ■ 7: (only for Evaluation mode = Long time history) The echo has been determined using the tank table and the multiple echo. ■ 8: (only for Evaluation mode = Long time history) The echo has been determined using the tank table and the end-of-probe or tank bottom signal.
<ul style="list-style-type: none"> ■ Max. draining speed ■ Max. filling speed 	<p>Meaning Maximum draining or filling speed obtained since the last reset.</p> <p>Evaluation Used to detect possible measured value spikes.</p> <p>Note This drag indicator can be reset via "Expert → Diagnostics → Min/max values → Reset min./max.".</p>
<ul style="list-style-type: none"> ■ Min. level value ■ Max. level value 	<p>Meaning Minimum or maximum level obtained since the last reset.</p> <p>Evaluation Used to detect possible measured value spikes.</p> <p>Note This drag indicator can be reset via "Expert → Diagnostics → Min/max values → Reset min./max.".</p>
<ul style="list-style-type: none"> ■ Time min. level ■ Time max. level 	<p>Meaning Time at which the minimum or maximum level has been obtained.</p> <p>Evaluation Helps to relate the recorded measured value peak to the process history.</p>
Configuration counter (HART, PROFIBUS PA)	<p>Meaning Is incremented with each change of a parameter.</p> <p> The creation of a verification report nitself implies a number of parameter changes. Therefore, the Configuration counter parameter will always be different in different reports.</p>

Monitoring parameter	Meaning/Remarks
<ul style="list-style-type: none"> ▪ Minimum value 1 to 2 ▪ Maximum value 1 to 2 (Advanced diagnostics)	<p>Meaning Minimum or maximum value the assigned measured variable has obtained since the last reset.</p> <p>Prerequisite An advanced diagnostics has been configured in the device.</p> <p>Measuring variable being evaluated</p> <ul style="list-style-type: none"> ▪ Is assigned in the Assign diagnostic signal 1 to 2 parameter ▪ If a foam detection (→  23) or build-up detection (→  26) have been configured by the respective wizard, the following measuring variables are automatically assigned: <ul style="list-style-type: none"> – Assign diagnostic signal 1 = Level linearized – Assign diagnostic signal 2 = Relative echo amplitude <p>Note This drag indicator can be reset via "Expert → Diagnostics → Advanced diagnostics 1 to 2 → Reset min./max. 1 to 2".</p>
Temperature (HART, PROFIBUS PA)	<p>Meaning Checks whether the temperature in the terminal compartment is within the critical limits.</p> <p>Evaluation Temperatures outside the critical limits may cause interruptions of the measurement.</p>
<ul style="list-style-type: none"> ▪ Max. electronics temperature ▪ Min. electronics temperature (HART, PROFIBUS PA)	<p>Meaning Checks whether the maximum or minimum electronics temperature obtained in the past is within the critical limits.</p> <p>Evaluation Temperatures outside the critical limits may cause interruptions of the measurement.</p> <p>Note These drag indicators can be reset via: Expert → Diagnostics → Min/max values → Reset min./max. temp..</p>

Integration of monitoring parameters in control systems

A number of monitoring parameters can be transmitted to the control system via the cyclic data traffic. The same is valid for additional parameters of the Advanced Diagnostics. Transmission to the control system uses the HART variables or the Analog Input Blocks, respectively.

Refer to the operating menu:

- HART:
Expert → Communication → Output → PV/SV/TV/QV
For details see the Description of Device Parameters GP01014F.
- PROFIBUS PA:
Expert → Analog inputs → Analog input N → Channel
For details see the Description of Device Parameters GP01018F.
- FOUNDATION Fieldbus:
Expert → Analog inputs → Analog input N → Channel
For details refer to the FOUNDATION Fieldbus specification.

5.2 Foam detection

- i** The **Foam detection** wizard is only visible for **Medium type = Liquid**. This is the case for FMR50, FMR51, FMR52, FMR53 and FMR54.
- i** Foam detection and build-up detection cannot be used at the same time. The **Foam detection** wizard will overwrite device parameters which may be used by the **Build-up detection** wizard as well. Therefore, the build-up detection will no longer work after a foam detection has been configured.

5.2.1 Operating principle

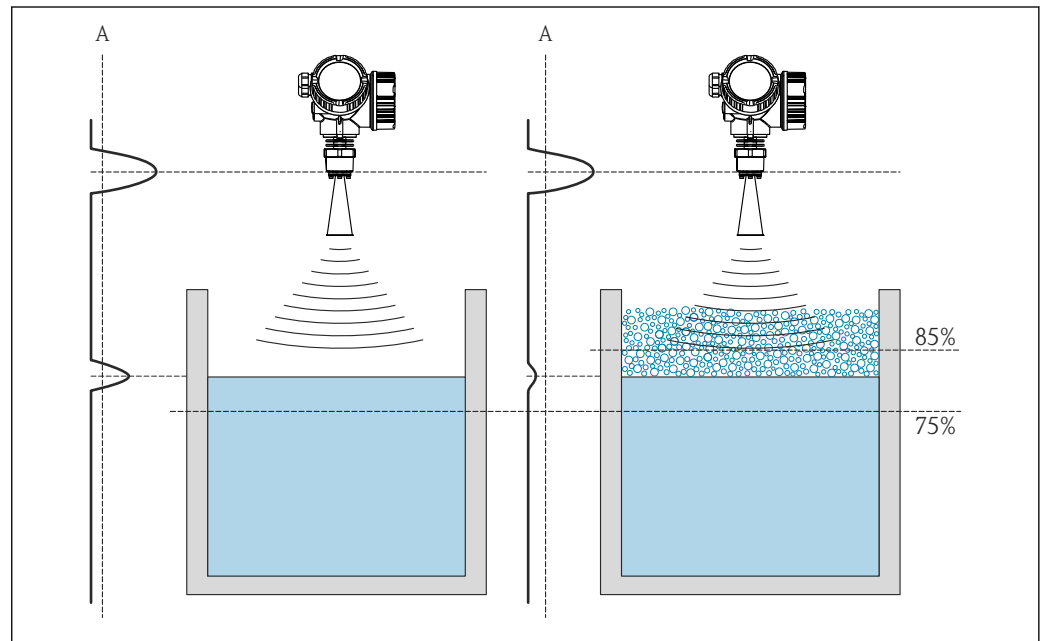

- 3** *Foam detection operating principle. The 75% and 85% limits are sample values. Values that suit the specific application must be selected in each case.*

A *Amplitude threshold for foam detection*

Foam reduces the echo amplitude and can therefore be detected automatically. Given that the echo amplitude also depends on the measured distance, foam detection should only be active if the level is in a user-defined range (75 to 85 % in the example indicated). Foam detection can be linked to a switch output in order to control a sprinkler system, for example, which dissolves the foam.

5.2.2 Configuration

i The **Foam detection** wizard is only available if the device is operated via FieldCare, DeviceCare, PACTware or a DTM-based process control system.

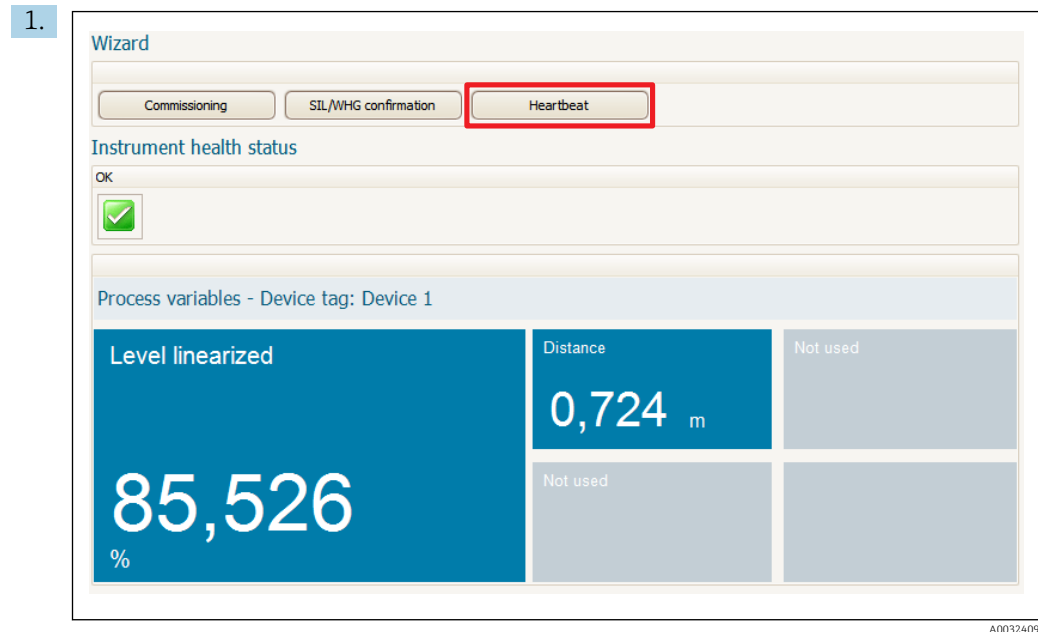

Click the **Heartbeat** button on the dashboard.
↳ A choice of heartbeat wizards is displayed.

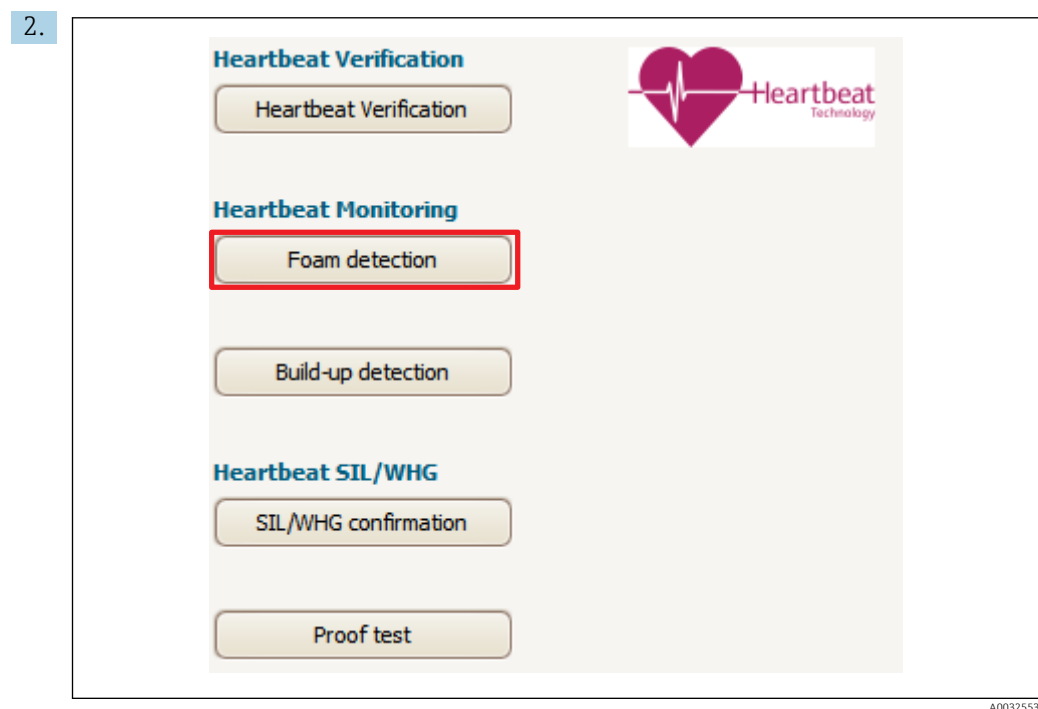

Select the **Foam detection** wizard.

3.

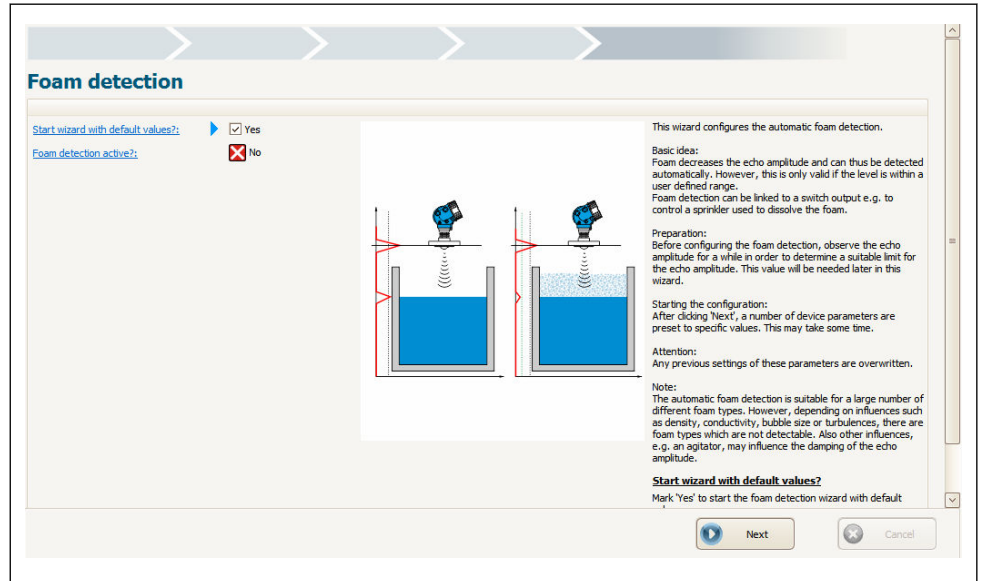

Follow the instructions given by the wizard.

- ↳ The wizard guides you through the entire configuration of the foam detection function.

5.3 Buildup detection

i Build-up detection and Foam detection cannot be used at the same time. The **Build-up detection** wizard will overwrite device parameters which may be used by the **Foam detection** wizard as well. Therefore, the foam detection will no longer work after a build-up detection has been configured.

5.3.1 Operating principle

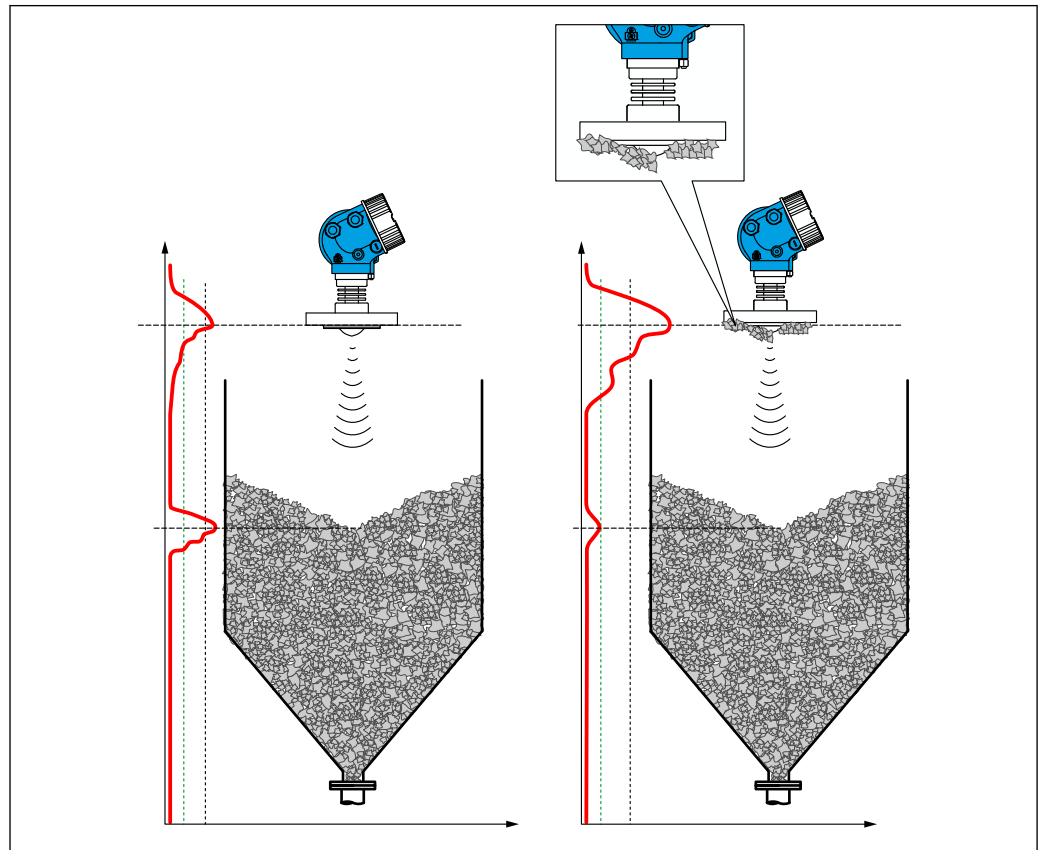

4 *Buildup detection operating principle*

A0032421

Buildup increases the area of the coupling signal and can therefore be detected automatically. Buildup detection can be linked to a switch output in order to control a compressed air system, for example, to clean the antenna.

i Condensate and buildup have a comparable influence on the coupling signal. Therefore the buildup detection function can also be used to detect condensation.

5.3.2 Configuration

i The **Build-up detection** wizard is only available if the device is operated via FieldCare, DeviceCare, PACTware or a DTM-based process control system.

1.

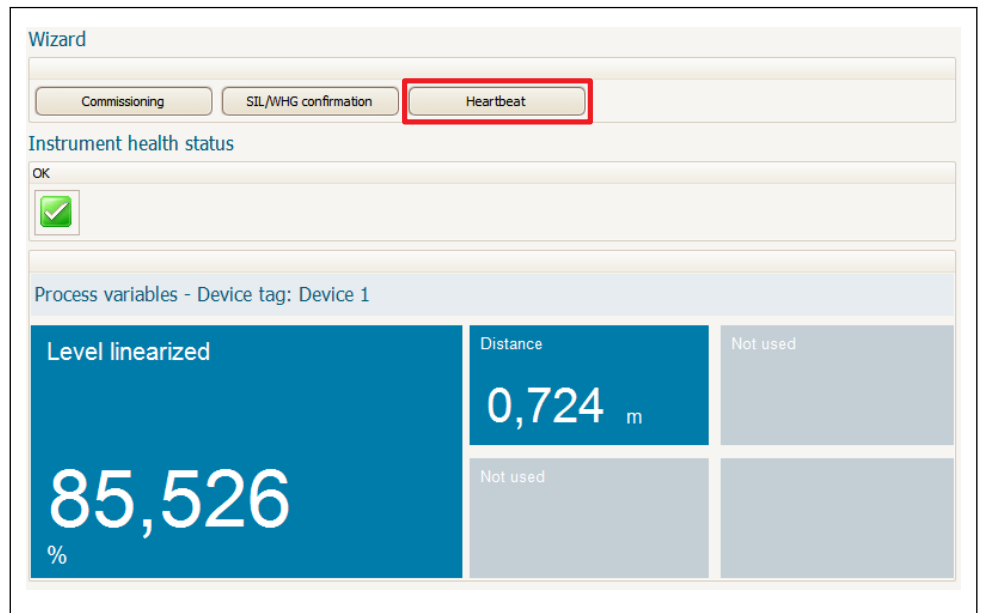

A0032409

Click the **Heartbeat** button on the dashboard.

↳ A choice of heartbeat wizards is displayed.

2.

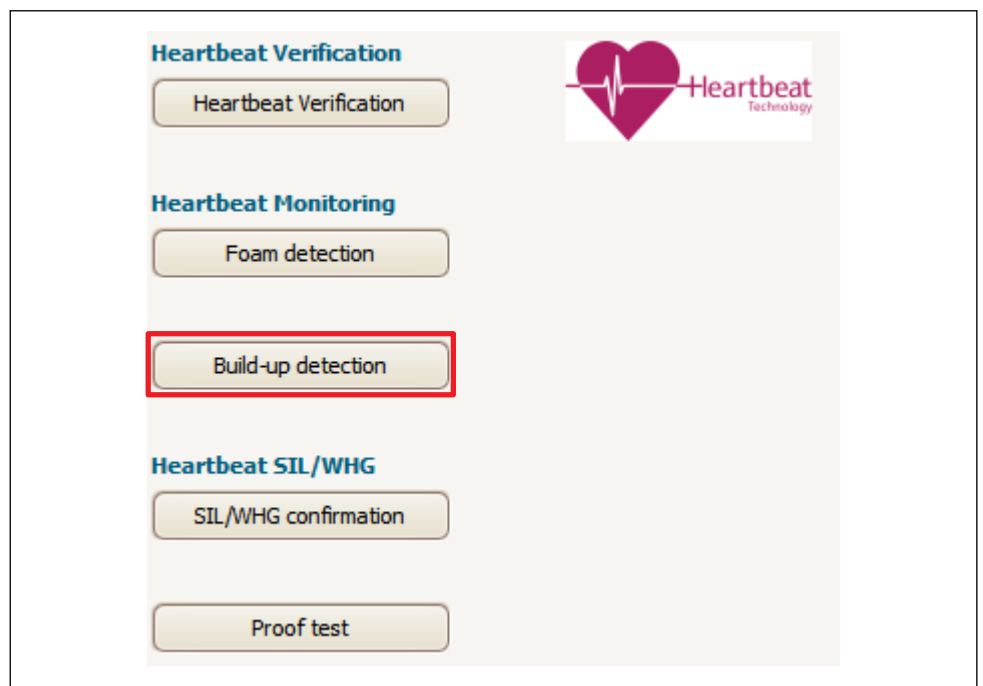

A0032554

Select the **Build-up detection** wizard.

3.

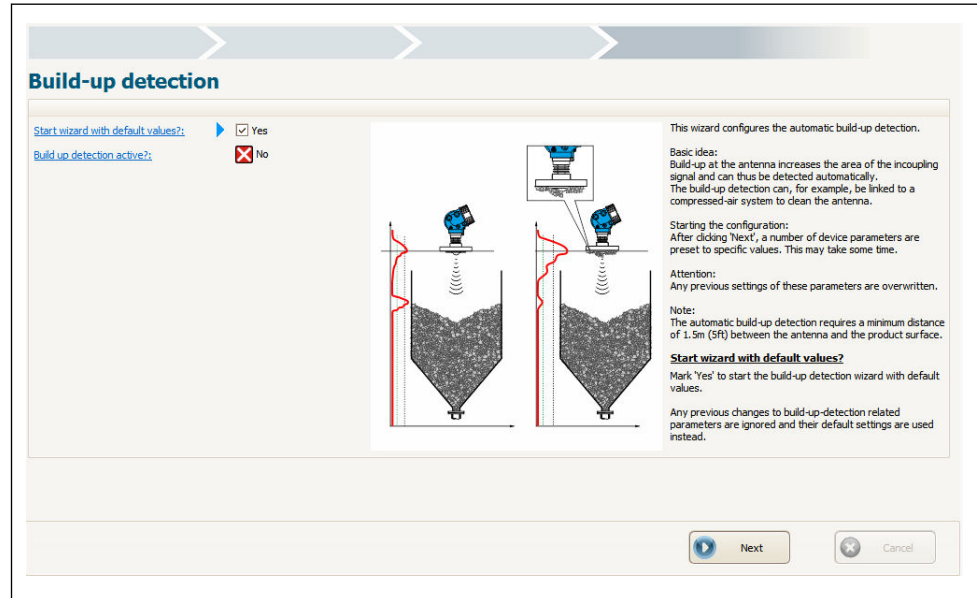

Follow the instructions given by the wizard.

- ↳ The wizard guides you through the entire configuration of the buildup detection function.



71386576

www.addresses.endress.com
