

Technical Information

Smart System for Surface Water SSP100

Package with smart sensors, for measuring the water quality of rivers or lakes

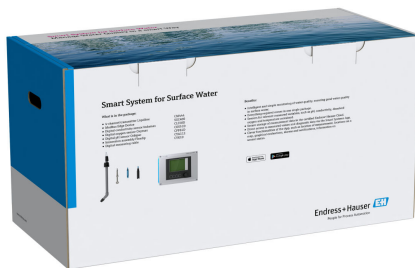

Application

The quality of water in rivers and lakes can quickly destabilize. Environmental, seasonal and human influences are frequently the reason. A reliable system to monitor water quality is therefore imperative. The Smart System for Surface Water combines high-end sensors with smart technology for data processing. This allows users to check important quality parameters, such as dissolved oxygen, pH value, conductivity or temperature, on their smartphone. Data export supported, e.g. for Smart City applications.





Your benefits

- Smart and simple monitoring of surface water quality, ensure good quality of water in rivers and lakes.
- Sensors for important quality parameters, such as dissolved oxygen, pH value, conductivity and temperature.
- Direct access to measured values and diagnostic data using smartphone app.
- Secure storage of measured data in the certified Endress+Hauser Cloud.
- Intelligent functions of the Smart Systems App, such as visualization of measuring locations on a map, graphic analysis, alerts and notifications, sensor status information, notification if servicing is required.
- To use the Smart System, users must register online and select a subscription plan. The subscription costs depend on the frequency of data transmission and are incurred additionally.









About this document

Symbols used

Safety symbols

Symbol	Meaning
	DANGER! This symbol alerts you to a dangerous situation. Failure to avoid this situation will result in serious or fatal injury.
	WARNING! This symbol alerts you to a dangerous situation. Failure to avoid this situation can result in serious or fatal injury.
	CAUTION! This symbol alerts you to a dangerous situation. Failure to avoid this situation can result in minor or medium injury.
	NOTE! This symbol contains information on procedures and other facts which do not result in personal injury.

Symbols for certain types of information

Symbol	Meaning
	Permitted Procedures, processes or actions that are permitted.
	Preferred Procedures, processes or actions that are preferred.
	Forbidden Procedures, processes or actions that are forbidden.
	Tip Indicates additional information.
	Reference to documentation.
	Reference to page.
	Reference to graphic.
	Visual inspection.

Function and system design

Function

The Smart System for Surface Water SSP100 monitors surface water. The package contains all the necessary components for this purpose, such as sensors to monitor the temperature, oxygen, conductivity and pH value. Other components include the transmitter for measurement data processing and the Modbus Edge Device SGC400 to connect to the Endress+Hauser Cloud. Fastening fixtures and connecting cables are also supplied. The Edge Device transmits the device ID data, measured values and status information to the Endress+Hauser Cloud. The data sent to the cloud can be either queried directly via a REST JSON API or used in a smartphone application.

System design

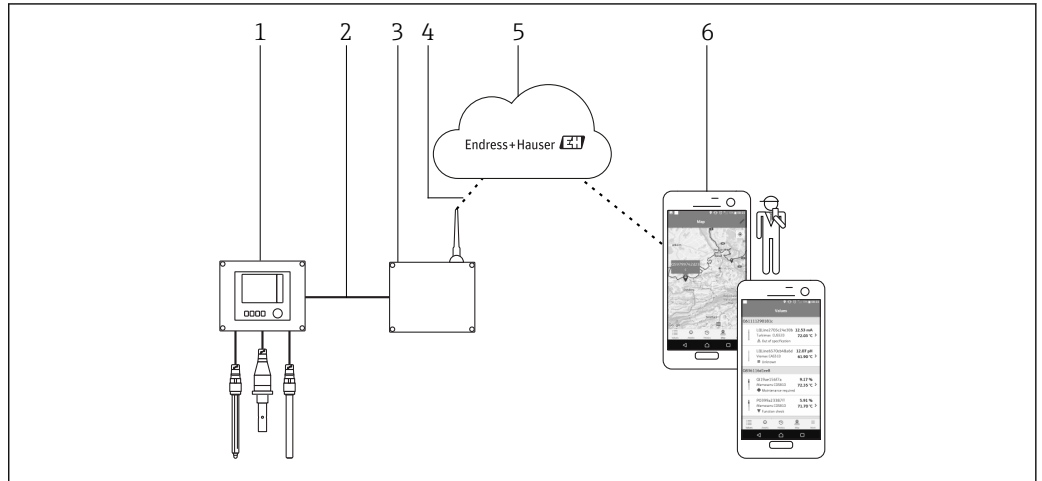

1 Network architecture

- 1 Field device e.g. Liquiline CM444
- 2 Modbus TCP connection
- 3 Modbus Edge Device SCG400
- 4 LTE connection
- 5 Endress+Hauser Cloud
- 6 User application on smartphone

SGC400 function and system design

Function

Endress+Hauser devices with Modbus TCP communication can be connected to the Endress+Hauser Cloud with the Modbus Edge Device SGC400. Point-to-point connections are supported. The Edge Device transmits the device ID data, measured values and status information to the Endress+Hauser Cloud. Connection to the web is via an integrated LTE modem with a global SIM card. The data sent to the cloud can be either queried directly via a REST JSON API or used in a smartphone application.

System design

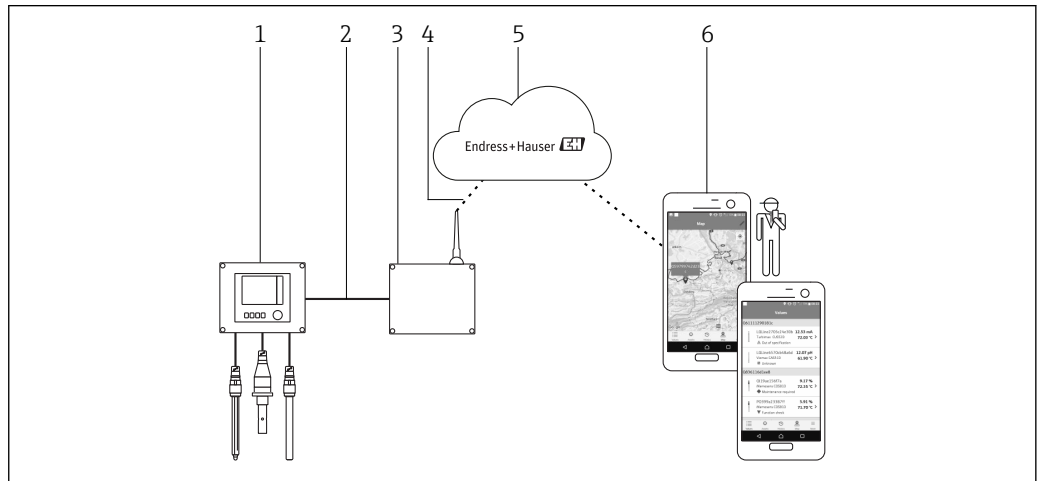

2 Network architecture

- 1 Field device e.g. Liquiline CM444
- 2 Modbus TCP connection
- 3 Modbus Edge Device SCG400
- 4 LTE connection
- 5 Endress+Hauser Cloud
- 6 User application on smartphone

Communication and data processing

Modbus TCP (Ethernet)	2x LAN port, 10/100 Mbps, comply with IEEE 802.3, IEEE 802.3u standards
Wireless LAN	IEEE 802.11b/g/n, Access Point (AP), Station (STA)
Mobile	4G (LTE) CAT4 up to 150 Mbps 3G up to 42 Mbps

CM444 function and system design

Measuring system

The overview shows examples of measuring systems. Other sensors and assemblies can be ordered for conditions specific to your application (www.endress.com/products).

Measuring point

A complete measuring system comprises:

- Transmitter Liquiline
- Sensors with Memosens technology
- Assemblies to suit the sensors used
- Post or rail mounting (optional)
- Weather protection cover (optional)

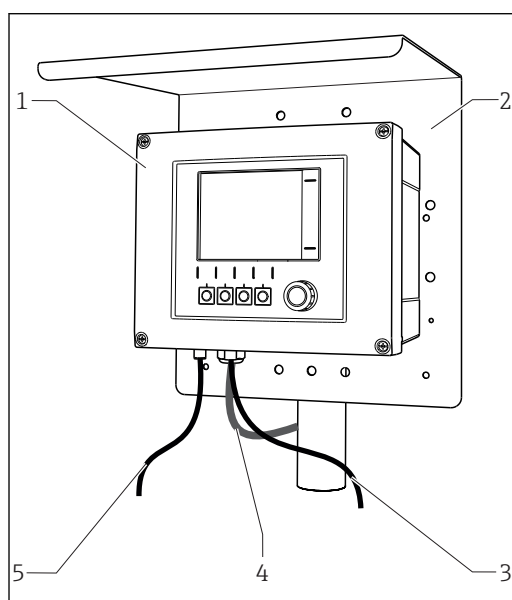

3 Measuring system (e.g. two-channel device)

- 1 Liquiline
- 2 Weather protection cover CYY101 (optional)
- 3, 5 Sensor cable CYK10 or fixed cable
- 4 Power supply cable (to be provided by the customer)

pH value or ORP

pH measurement in drinking water (→ Fig.)

- Retractable assembly Cleanfit CPA871
- Sensor Orbisint CPS11D
- Measuring cable CYK10

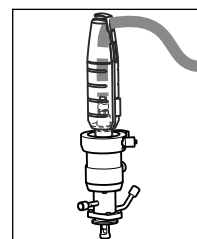

ORP in drinking water

- Dipfit CYA112 immersion assembly
- Sensor Orbisint CPS12D
- Measuring cable CYK10

Conductivity

Inductive conductivity measurement in wastewater treatment

- Sensor Indumax CLS50D
- Sensor fixed cable

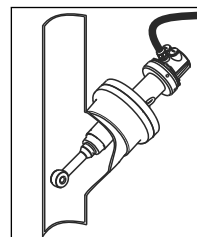

Conductive conductivity measurement in power plant cooling water

- Sensor Condumax CLS15D
- Measuring cable CYK10

Oxygen

Oxygen in aeration basins

- Dipfit CYA112 immersion assembly
- Holder CYH112
- Sensor
 - COS61D (optical) with fixed cable (→ Fig.)
 - COS51D (amperometric), cable CYK10

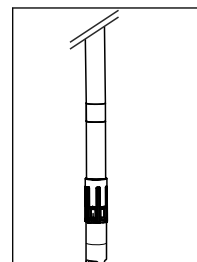

Nitrate and SAC

Nitrate in wastewater

- Sensor CAS51D-**A2 with fixed cable
- Dipfit CYA112 immersion assembly
- Holder CYH112

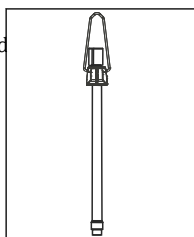

SAC in the wastewater treatment outlet

- Sensor CAS51D-**2C2 with fixed cable
- Dipfit CYA112 immersion assembly
- Holder CYH112

Turbidity and interface

Turbidity in industrial water

- Sensor Turbimax CUS51D with fixed cable (→ Fig.)
- Assembly Flowfit CUA250
- Spray head CUR3 (optional)

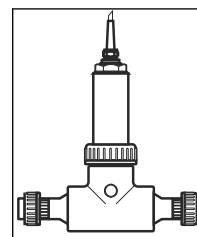

Interface in the primary clarifier

- Sensor Turbimax CUS71D
- Assembly CYA112
- Holder CYH112

Disinfection

Free available chlorine (and pH) in drinking water

- Sensor CCS142D
- Sensor CPS11D
- Measuring cable CYK10
- Flow assembly CCA250

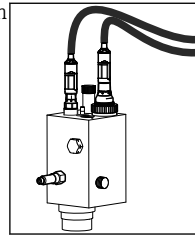

Ion-selective electrodes

Ammonium and nitrate measurement in the aeration basin

- Sensor CAS40D with fixed cable
- Holder CYH112

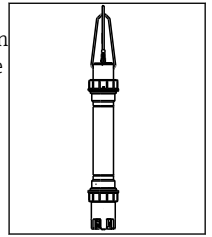

 If mounting outdoors, always use the weather protection cover (see "Accessories") to protect the transmitter against weather conditions.

Application example

Measuring point at wastewater treatment plant outlet (open channel)

- Transmitter CM444-AAM44AOFF with:
 - 4x Memosens, Modbus TCP, 4 x relays for cleaning/limit value, 2 x analog current input
- pH and temperature with CPS11D, item 1, (www.endress.com/cps11d)
- Turbidity with CUS51D, item 2, (www.endress.com/cus51d)
- Nitrate with CAS51D, item 3, (www.endress.com/cas51d)
- Spectral absorption coefficient with CAS51D, item 4, (www.endress.com/cas51d)
- Flow from external measurement via current input
- Assembly holder CYH112 with assemblies CYA112 (www.endress.com/cyh112)

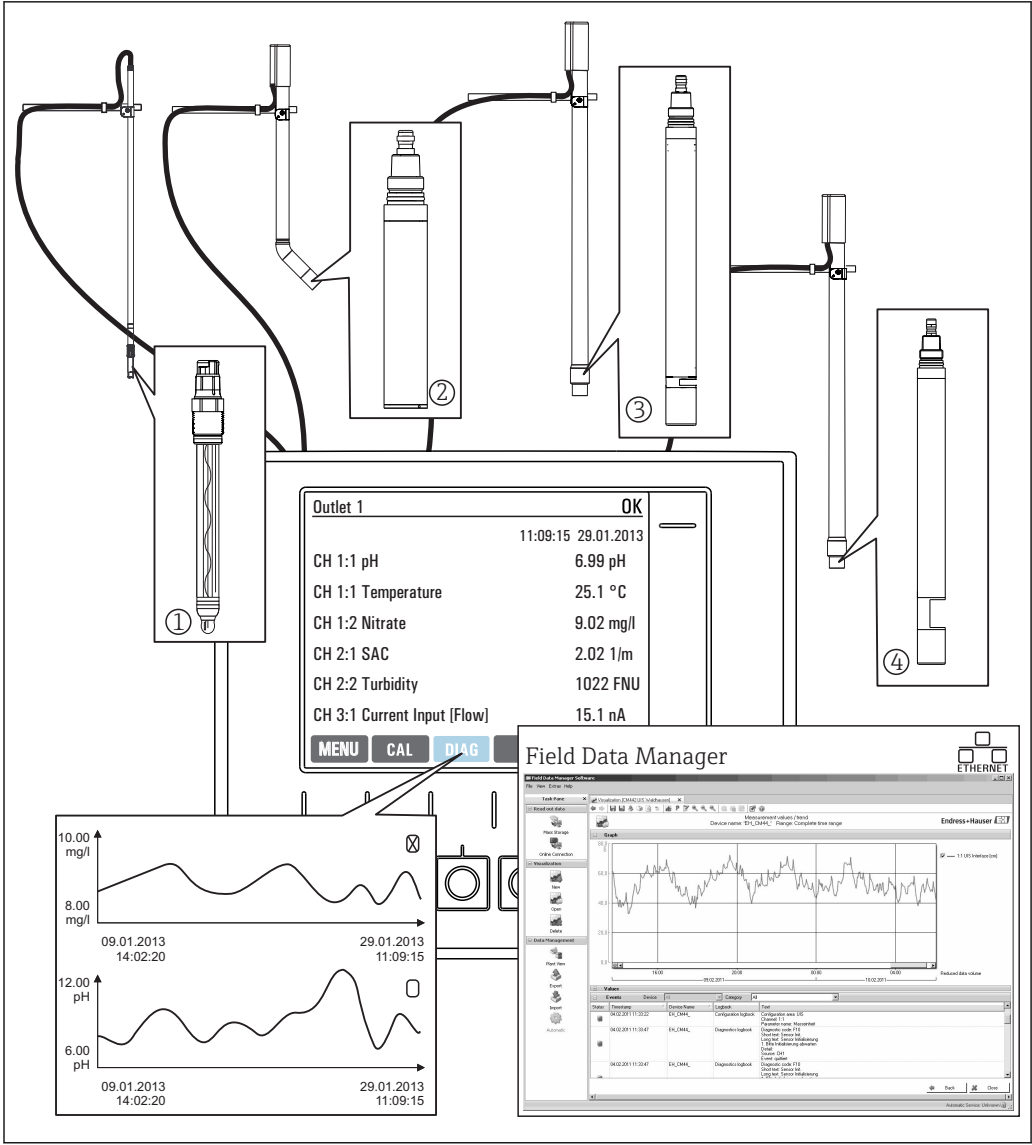

A0025077

4 Measuring point at wastewater treatment plant outlet

Data retention

- Storage of all measured values, incl. values of external sources, in the non-volatile memory (data logbook)
- Data called up on site via user-defined measuring menu and load curve display of the data logbook
- Transmission of data by ethernet, CDI interface or SD card and storage in a tamper-proof database (Field Data Manager)
- Data export to csv file (for Microsoft Excel)

Equipment architecture

Slot and port assignment

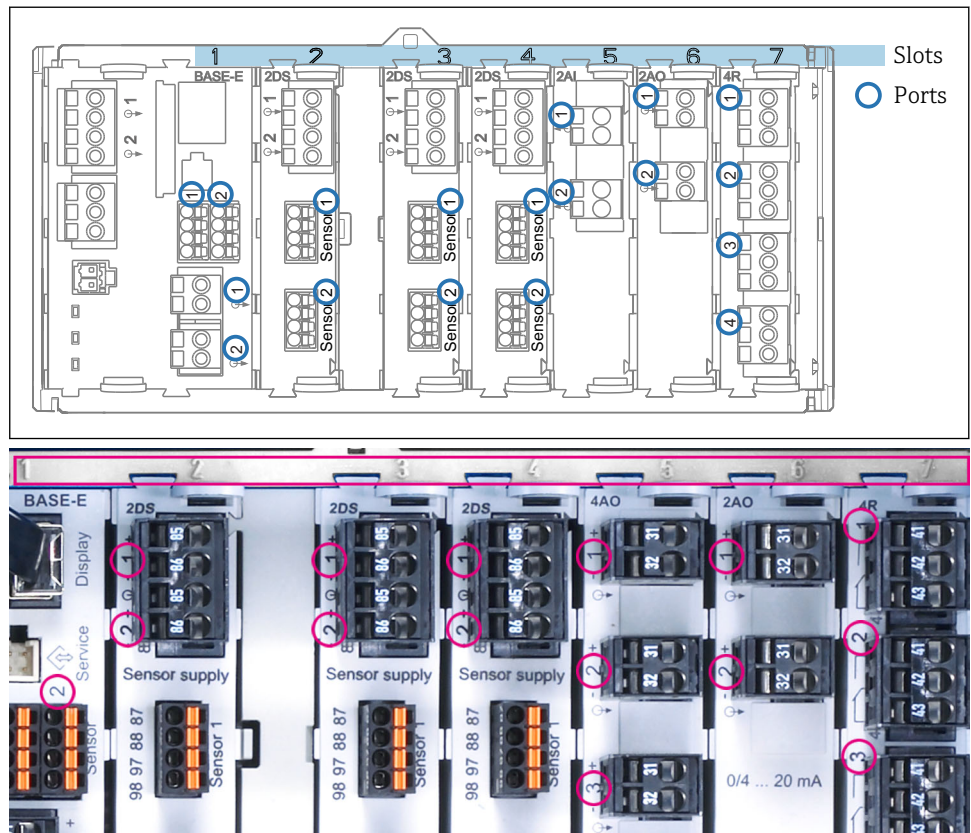

5 Slot and port assignment of the hardware modules

Outlet 1	OK
CH1: 1:1 pH Glass ATC 6.95 pH	Port Slot
CH2: 1:2 TU/TS 500.0 g/l	
CH3: 5:1 SAC 500.0 1/m	
CH4: 5:2 Cond i ATC 2.62 mS/cm	
CH5: 6:1 Chlorine 28.33 mg/l	
CH6: 6:2 Redox ± 51 mV	
CH7: 7:1 Oxygen (am... 32.86 mg/l	
CH8: 7:2 Cond c ATC 131.1 pS/cm	
MENU CAL DIAG HOLD	

6 Slot and port assignment on the display

- Inputs are assigned to measuring channels in the ascending order of the slots and ports. Adjacent example: "CH1: 1:1 pH glass" means: Channel 1 (CH1) is slot 1 (basic module) : Port 1 (input 1), pH glass sensor
- Outputs and relays are named according to their function, e.g. "current output", and are displayed with the slot and port numbers in ascending order

Order of the modules

Depending on the version ordered, the device is supplied with a number of electronic modules, which are assigned in a specific sequence in ascending order to slots 0 to 7. If you do not have a particular module, the next moves up automatically:

- The basic module (which is always present) always occupies slots 0 and 1
- Fieldbus module 485 or Ethernet module ETH (only one of the two modules can be used)
- Memosens input module 2DS (DS = digital sensor)
- Extension module for digital inputs and outputs DIO (DIO = digital input and output)
- Current input module 2AI (AI = analog input)
- Current output module 4AO or 2AO (AO = analog output)
- Relay modules AOR, 4R or 2R (AOR = analog output + relay, R = relay)

i Modules with 4 ports are connected before modules of the same type with 2 ports.

Basic rule for hardware upgrades

- i** Please note the following if upgrading the device:
- The sum of all current inputs and outputs may not exceed 8!
 - A maximum of two "DIO" modules may be used.

Determining the hardware delivery status

You must be aware of the type of modules and the number of them supplied with the device you have ordered to determine the delivery status of your Liquiline.

- Basic module
One basic module in all versions. Always occupies slots 0 and 1.
- Fieldbus module
Optional, and only one fieldbus module is possible.
- Input modules
 - Must be clearly assigned to the number of optional inputs ordered.
 - Examples:
2 current inputs = module 2AI
4 Memosens inputs = 2 inputs with basic module + module 2DS with 2 further inputs
- Current outputs and relays
Various module combinations can exist.
The following table will help you determine which modules your device has, depending on the type and number of outputs.

Current outputs	Relays		
	0	2	4
2	-	1 x 2R	1 x 4R
4	1 x 2AO	1 x AOR	1 x 2AO + 1 x 4R
6	1 x 4AO	1 x 4AO + 1 x 2R	1 x 4AO + 1 x 4R
8	1 x 4AO + 1 x 2AO	1 x 4AO + 1 x 2AO + 1 x 2R	1 x 4AO + 1 x 2AO + 1 x 4R

- ▶ Sum up the number of modules and sort them according to the specified sequence .
 - ↳ This will give you the slot assignment for your device.

Terminal diagram

- i** The unique terminal name is derived from:
Slot no. : Port no. : Terminal

Example, NO contact of a relay

Device with 4 inputs for digital sensors, 4 current outputs and 4 relays

- Base module BASE-E (contains 2 sensor inputs, 2 current outputs)
- 2DS module (2 sensor inputs)
- 2AO module (2 current outputs)
- 4R module (4 relays)

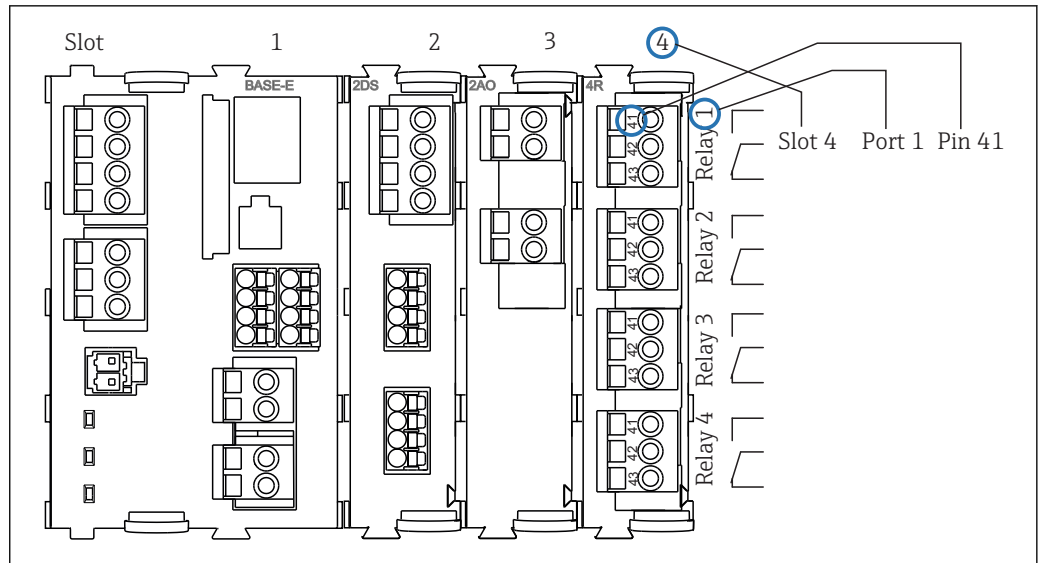

A0025105

7 Creating a terminal diagram using the example of the NO contact (terminal 41) of a relay

Device configuration using the example of a CM442- **M1A1F0*

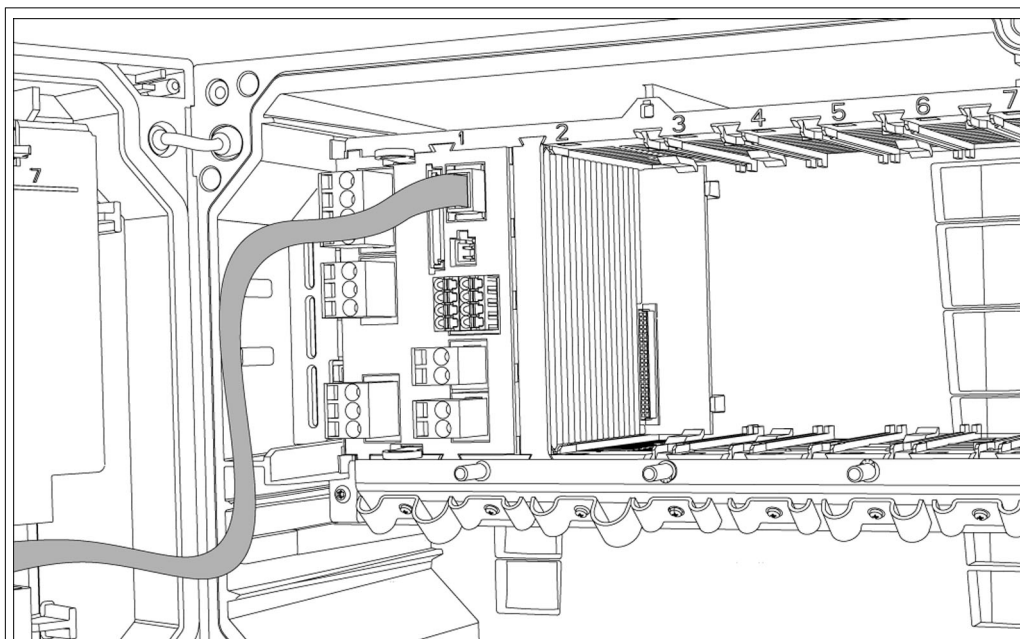

Ordered basic device (example)	<ul style="list-style-type: none"> ▪ Order code CM442-**M1A1F0* ▪ Functionality: 1 x Memosens, 2 current outputs without HART
Extension options without additional modules	<ul style="list-style-type: none"> ▪ Second Memosens input (71114663) ▪ HART with activation code (71128428)
Extension options by using an extension module in free slot 2	<ul style="list-style-type: none"> ▪ Ethernet/PROFIBUS DP/Modbus with module 485 incl. activation code for the desired communication protocol: <ul style="list-style-type: none"> – PROFIBUS DP (71140888) – Modbus RS485 (71140889) – Modbus TCP (71140890) – EtherNet/IP (71219868) – Only Ethernet without fieldbus (71135634) <p>If fieldbus communication is subsequently required, an activation code is needed for this.</p> ▪ Alternative for Ethernet or Modbus TCP: module ETH ▪  If you retrofit module 485, any existing current outputs are disabled! Alternative: ETH (Ethernet, Modbus TCP only). <p>Additional inputs or outputs, relays:</p> <ul style="list-style-type: none"> – Module 2AI (71135639): 2 current inputs – Module 2AO (71135632): 2 current outputs – Module AOR (71111053): 2 current outputs, 2 relays – Module 2R (71125375) or 4R (71125376): 2 or 4 relays – Module DIO (71135638): 2 digital inputs and 2 digital outputs
Device upgrade to CM444 or CM448	<ul style="list-style-type: none"> ▪ Upgrade kit 71135644 (100 to 230 V AC) or 71211434 (24 V DC) <ul style="list-style-type: none"> – Extension power supply unit and backplane – BASE-E (Memosens inputs same as for base device) – 6 slots for extension modules ▪ Extension options: <ul style="list-style-type: none"> – Second Memosens input (71114663), additional modules same as for CM442 – Up to 8 measuring channels by using an appropriate number of Memosens input modules 2DS (71135631)
Basic rule for extensions	The sum of all current inputs and outputs may not exceed 8!
Restrictions if using CUS71D sensors for interface measurement	Only one CUS71D can be connected. The second Memosens input may not be used.
Product Configurator	www.endress.com/cm442

Device configuration using the example of a CM444- **M42A1FA*

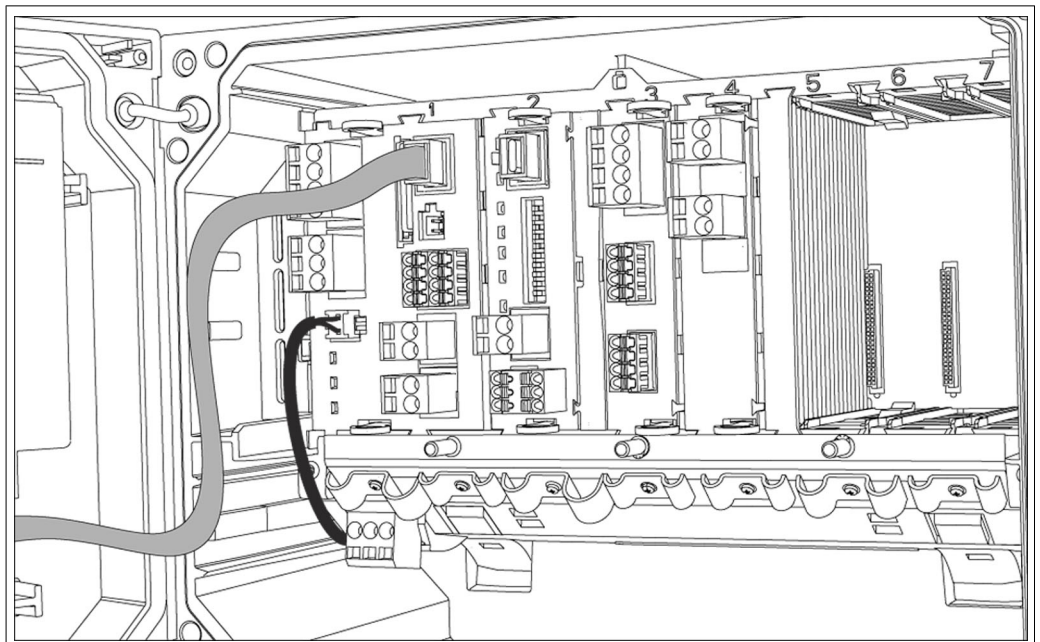

<p>Ordered basic device (example)</p>	<ul style="list-style-type: none"> ■ Order code CM444- **M42A1FA* ■ Functionality: <ul style="list-style-type: none"> - 4 x Memosens (2 on BASE-E module + 2 on an extension module 2DS) - PROFIBUS communication (module 485) - 2 current outputs without HART (on BASE-E module) - 2 current inputs (module 2AI) <p>3 slots are still free in this example. More or fewer slots can be free in other versions.</p>
<p>Extension options without additional modules</p>	<p>None</p>
<p>Modification options without additional modules</p>	<ul style="list-style-type: none"> ■ Communication type changed by entering activation code. This disables the communication type used previously! <ul style="list-style-type: none"> - Modbus RS485 (71140889) - Modbus TCP (71140890) - EtherNet/IP (71219868) ■ Retrofit to HART by removing module 485 and entering activation code for HART (71128428)
<p>Extension options by using extension modules in free slots 5-7</p>	<p>Only the following is possible for the example above: Module 2R (71125375) or 4R (71125376): 2 or 4 relays</p> <p>If extending to eight measuring channels:</p> <ul style="list-style-type: none"> ■ Module 2DS (71135631): 2 Memosens inputs ■ Use of the 2 current outputs in the basic module by entering activation code (71140891) <p>Additional inputs or outputs and relays if fieldbus module 485 is removed:</p> <ul style="list-style-type: none"> ■ Module 2AO (71135632): 2 current outputs ■ Module AOR (71111053): 2 current outputs, 2 relays ■ Module 2R (71125375) or 4R (71125376): 2 or 4 relays ■ Module DIO (71135638): 2 digital inputs and 2 digital outputs <p>i If you replace module 485 with ETH, you can operate up to 6 current outputs in addition to the ETH module's ethernet or Modbus function. Only two current outputs are possible with 485.</p>
<p>Basic rule for extensions</p>	<p>The sum of all current inputs and outputs may not exceed 8!</p>
<p>Restrictions if using CUS71D sensors for interface measurement</p>	<ul style="list-style-type: none"> ■ With the CM444, any combination of maximum 4 Memosens sensors is possible. ■ An extension to CM448 is not advisable as the maximum number of Memosens inputs remains limited to 4 if a CUS71D is used.

Product Configurator	www.endress.com/cm444
-----------------------------	--

Function diagram CM444

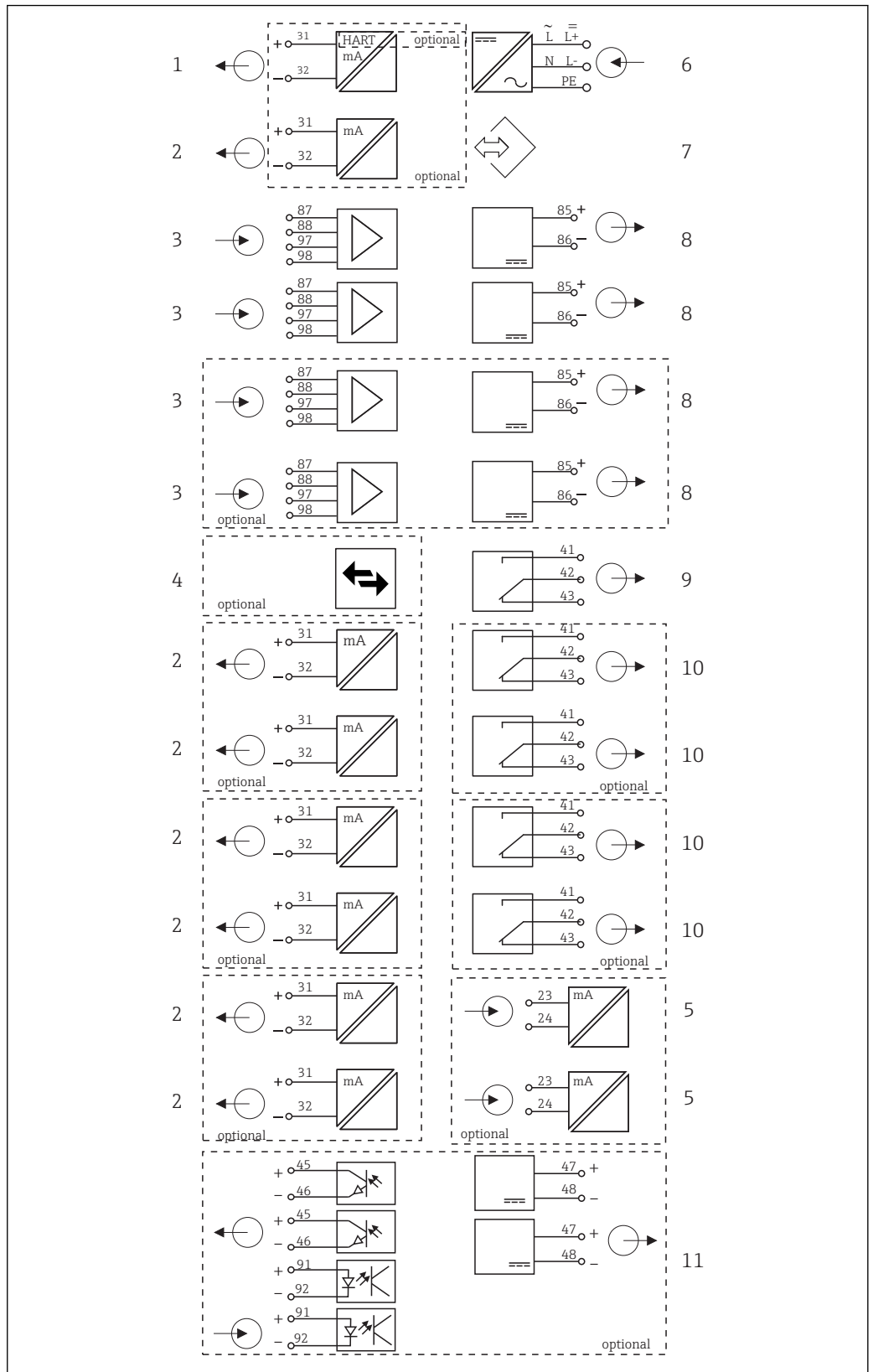

A0015827

8 Block circuit diagram CM444

1	Current output 1:1, + HART (both optional)	6	Power connection
2	Max. 7 x current output (optional)	7	Service interface
3	Memosens input (2 x standard + 2 x optional)	8	Power supply, fixed cable sensors
4	PROFIBUS DP/Modbus/Ethernet (optional)	9	Alarm relay
5	2 x current input (optional)	10	2 or 4 x relays (optional)
		11	2 digital inputs and outputs (optional)

Communication and data processing

Types of communication:

- Fieldbuses
 - HART
 - PROFIBUS DP (Profile 3.02)
 - Modbus TCP or RS485
- EtherNet/IP



Only one type of Fieldbus communication can ever be active. The last activation code entered decides which bus is used.

The device drivers available make it possible to perform a basic setup and display measured values and diagnostics information via the fieldbus. A full device configuration via the fieldbus is not possible.

Extension module 485 and current outputs

For PROFIBUS DP, Modbus and Ethernet communication protocols:

- Current outputs cannot be used in parallel. Any existing current outputs are deactivated with the installation of 485.
- CM444/CM448
 - A maximum of 2 current outputs can be used in parallel.

Extension module ETH and current outputs

- Communication via Ethernet or EtherNet/IP
- CM442
 - A maximum of 2 current outputs can be used in parallel.
- CM444 and CM448
 - A maximum of 6 current outputs can be used in parallel.

Bus termination on the device

- Via slide switch at bus module 485
- Displayed via LED "T" on bus module 485

Reliability

Memosens

Memosens makes your measuring point safer and more reliable:

- Non-contact, digital signal transmission enables optimum galvanic isolation
- No contact corrosion
- Completely watertight
 - Can even be connected under water
 - No contact corrosion
 - Measured value not affected by moisture. Correct transmission of even the smallest values, such as from amperometric sensors.
- Sensor can be calibrated in a lab, thus increasing the availability of the measuring point in the process
- Intrinsically safe electronics mean operation in hazardous areas is not a problem.
- Predictive maintenance thanks to recording of sensor data, e.g.:
 - Total hours of operation
 - Hours of operation with very high or very low measured values
 - Hours of operation at high temperatures
 - Number of steam sterilizations
 - Sensor condition

Heartbeat diagnostics

- Heartbeat diagnostics screen with graphic indicators for the health of the device and sensor and with a maintenance or (sensor-dependent) calibration timer
- Heartbeat status information on the health of the device and the condition of the sensor
 - ☺: Sensor/device condition or maintenance timer > 20 %; no action is required
 - ☹: Sensor/device condition or maintenance timer > 5 ≤ 20 %, maintenance not yet urgent but should be scheduled
 - ☹: Sensor/device condition or maintenance timer < 5 %, maintenance is recommended
- The Heartbeat sensor condition is the assessment of the calibration results and the sensor diagnostic functions.

An unhappy smiley can be due to the calibration result, the measured value status or to the operating hours limit having been exceeded. These limits can be configured in the sensor setup in a way that adapts the Heartbeat diagnostics to the application.

Heartbeat and NAMUR category

The Heartbeat status indicates the sensor or device condition while the NAMUR categories (F, C, M, S) assess the reliability of the measured value. The two conditions can correlate but do not have to.

▪ Example 1

- The number of remaining cleaning cycles for the sensor reaches 20% of the defined maximum number. The Heartbeat symbol changes from ☺ to ☹. The measured value is still reliable so the NAMUR status signal does not change.
- If the maximum number of cleaning cycles is exceeded, the Heartbeat symbol changes from ☹ to ☹. While the measured value can still be reliable, the NAMUR status signal changes to M (maintenance required).

▪ Example 2

The sensor breaks. The Heartbeat status changes immediately from ☺ to ☹ and the NAMUR status signal also changes immediately to F (failure).

Heartbeat Monitoring

Sensor data from Memosens sensors are transmitted via the EtherNet/IP and Modbus TCP fieldbus protocols. These data can be used for predictive maintenance, for instance.

Examples include:

- Total hours of operation
- Hours of operation with very high or very low measured values
- Hours of operation at high temperatures
- Number of steam sterilizations
- Sensor identification
- Calibration information



SD EtherNet/IP and Modbus

Heartbeat Verification

Heartbeat Verification makes it possible to verify the correct operation of the measuring device without interrupting the process. This verification can be documented anytime.

Sensor Check System (SCS)

The Sensor Check System (SCS) monitors the high impedance of the pH glass. An alarm is issued if a minimum impedance value is undershot or a maximum impedance is exceeded.

- Glass breakage is the main reason for a drop in high impedance values
- The reasons for increasing impedance values include:
 - Dry sensor
 - Worn pH glass membrane



For the SCS, upper and lower limit values can be enabled or disabled independently of one another.

Process Check System (PCS)

The process check system (PCS) checks the measuring signal for stagnation. An alarm is triggered if the measuring signal does not change over a specific period (several measured values).

The main causes of stagnating measured values are:

- Contaminated sensor, or sensor outside of medium
- Sensor defective
- Process error (e.g. through control system)

Self-monitoring functions

Current inputs are deactivated in the event of overcurrent and reactivated once the overcurrent stops. Board voltages are monitored and the board temperature is also measured.

USP and EP

The limit functions for pharmaceutical water in accordance with USP and EP specifications are implemented in the software for conductivity measurements:

- "Water for Injection" (WFI) as per USP <645> and EP
- "Highly Purified Water" (HPW) as per EP
- "Purified Water" (PW) as per EP

The uncompensated conductivity value and the temperature are measured for the USP/EP limit functions. The measured values are compared against the tables defined in the standards. An alarm is triggered if the limit value is exceeded. Furthermore, it is also possible to configure an early warning alarm that signals undesired operating states before they occur.

ChemocleanPlus

Freely programmable sequence control

- e.g. for automatic sensor cleaning in retractable assemblies for reliable measurement results in processes with a high risk of contamination
- Individual, time-based activation of 4 outputs e.g. relays
- Starting, stopping or pausing of activities via digital input or fieldbus signals e.g. from limit position switches

CPF81D function and system design**Measuring principle****pH measurement**

The pH value is used as a unit of measurement for the acidity or alkalinity of a liquid medium. The membrane glass of the electrode supplies an electrochemical potential which is dependent upon the pH value of the medium. This potential is generated by the selective penetration of H⁺ ions through the outer layer of the membrane. An electrochemical boundary layer with an electric potential forms at this point. An integrated Ag/AgCl reference system serves as the required reference electrode. The transmitter converts the measured voltage into the corresponding pH value using the Nernst equation.

ORP measurement

The ORP potential is a unit of measurement for the state of equilibria between oxidizing and reducing components of a medium. The ORP is measured using a platinum or gold electrode instead of the pH-sensitive glass membrane. Analog to the pH measurement, an integrated Ag/AgCl reference system is used as a reference electrode.

Measuring system

A complete measuring system comprises:

- Sensor CPF81D, CPF81, CPF82D or CPF82
- Transmitter, e.g. Liquiline CM44x/R or Liquiline M CM42
- Measuring cable, e.g. CYK10 or sensor's fixed cable

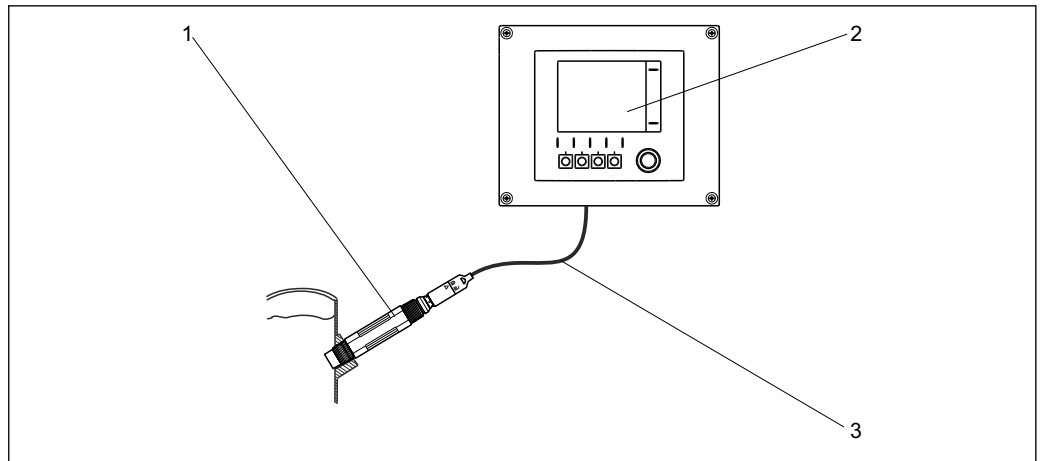

A0024721

9 Example of a measuring system

- 1 Sensor CPF81D
- 2 Liquiline CM44x transmitter
- 3 Measuring cable CYK10

Communication and data transmission

Communication with the transmitter

Always connect digital sensors to a transmitter with Memosens technology. Data transmission to a transmitter for analog sensors is not possible.

The digital sensors are able to store the following system data in the sensor.

- Manufacturing data
 - Serial number
 - Order code
 - Date of manufacture
- Calibration data
 - Calibration date
 - Calibrated slope at 25 °C (77 °F) (CPF81D)
 - Calibrated zero point at 25 °C (77 °F) (CPF81D)
 - Calibrated offset (ORP mV measuring mode)
 - Slope as % (ORP % measuring mode)
 - Temperature offset
 - Number of calibrations
 - Serial number of the transmitter used for the last calibration
 - Calibration database (stores the last 8 calibrations in the Memosens head)
- Application data
 - Temperature application range
 - pH application range (CPF81D)
 - ORP application range
 - Date of first commissioning
 - Maximum temperature value
 - Operating hours at temperatures above 80 °C (176 °F) and 100 °C (212 °F)
 - Operating hours at very low and very high pH values (Nernst voltage below -300 mV, above +300 mV)

Dependability

Reliability

Easy handling

Sensors with Memosens technology have integrated electronics that allow for saving calibration data and further information such as total hours of operation and operating hours under extreme measuring conditions. Once the sensor has been connected, the sensor data are transferred automatically to the transmitter and used to calculate the current measured value. As the calibration

data are stored in the sensor, the sensor can be calibrated and adjusted independently of the measuring point. The result:

- Easy calibration in the measuring lab under optimum external conditions increases the quality of the calibration.
- Pre-calibrated sensors can be replaced quickly and easily, resulting in a dramatic increase in the availability of the measuring point .
- Maintenance intervals can be defined based on all stored sensor load and calibration data and predictive maintenance is possible.
- The sensor history can be documented on external data carriers and evaluation programs at any time. Thus, the current application of the sensors can be made to depend on their previous history.

Integrity

Data security thanks to digital data transmission

Memosens technology digitizes the measured values in the sensor and transmits the data to the transmitter using a non-contact connection that is free from potential interference. The result:

- Automatic error message if sensor fails or connection between sensor and transmitter is interrupted
- Immediate error detection increases measuring point availability

Safety

Maximum process safety

With inductive transmission of the measured value using a non-contact connection, Memosens guarantees maximum process safety and offers the following benefits:

- All problems caused by moisture are eliminated.
 - Plug-in connection free from corrosion
 - Measured value distortion from moisture is not possible.
 - The plug-in system can even be connected under water.
- The transmitter is galvanically decoupled from the medium. Issues concerning "symmetrical high-impedance" or "asymmetry" or an impedance converter are a thing of the past.
- EMC safety is guaranteed by screening measures for the digital transmission of measured values.

CLS50D function and system design

Measuring principle

Inductive conductivity measurement

An oscillator (1) generates an alternating magnetic field in the primary coil (5), which induces a current flow (4) in the medium. The strength of the current depends on the conductivity and thus on the ion concentration in the medium. The current flow in the medium, in turn, generates a magnetic field in the secondary coil (3). The resulting induced current is measured by the receiver (2) and used to determine the conductivity.

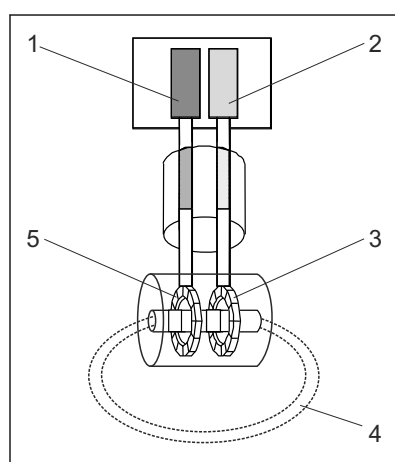

- 1 Oscillator
- 2 Receiver
- 3 Secondary coil
- 4 Current flow in the medium
- 5 Primary coil

Advantages of inductive conductivity measurement:

- No electrodes and therefore no polarization effects
- Accurate measurement in media with a high degree of pollution and a tendency to form buildup
- Complete galvanic isolation of the measurement and the medium

Measuring system

CLS50D

A complete measuring system comprises:

- A CLS50D inductively measuring conductivity sensor with fixed cable
- A transmitter, e.g. Liquiline CM44x

Optional:

- Weather protection for the field installation of the transmitter
- Assembly to install the sensor in vessels or pipes, e.g. CLA111

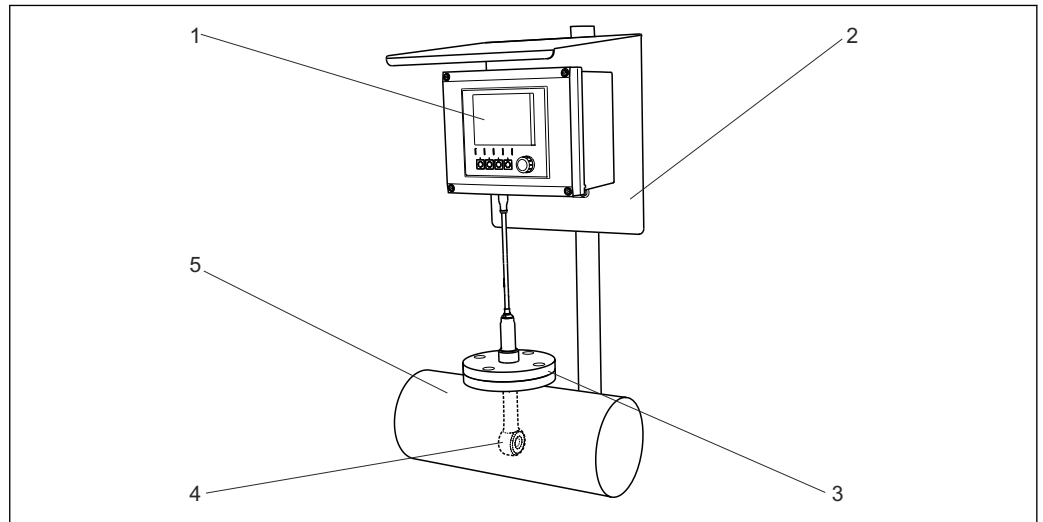

A0024929

10 Example of a measuring system

- 1 Liquiline CM44x transmitter
- 2 Protective cover
- 3 Pipe nozzle with flange DN50 PN16
- 4 CLS50D sensor, version with flange DN50 PN16 and fixed cable with M12 connector
- 5 Pipe

CLS50

A complete measuring system comprises:

- A CLS50 inductively measuring conductivity sensor with fixed cable
- A transmitter, e.g. Liquiline M CM42

Optional:

- Weather protection for the field installation of the transmitter
- Assembly to install the sensor in vessels or pipes, e.g. CLA111

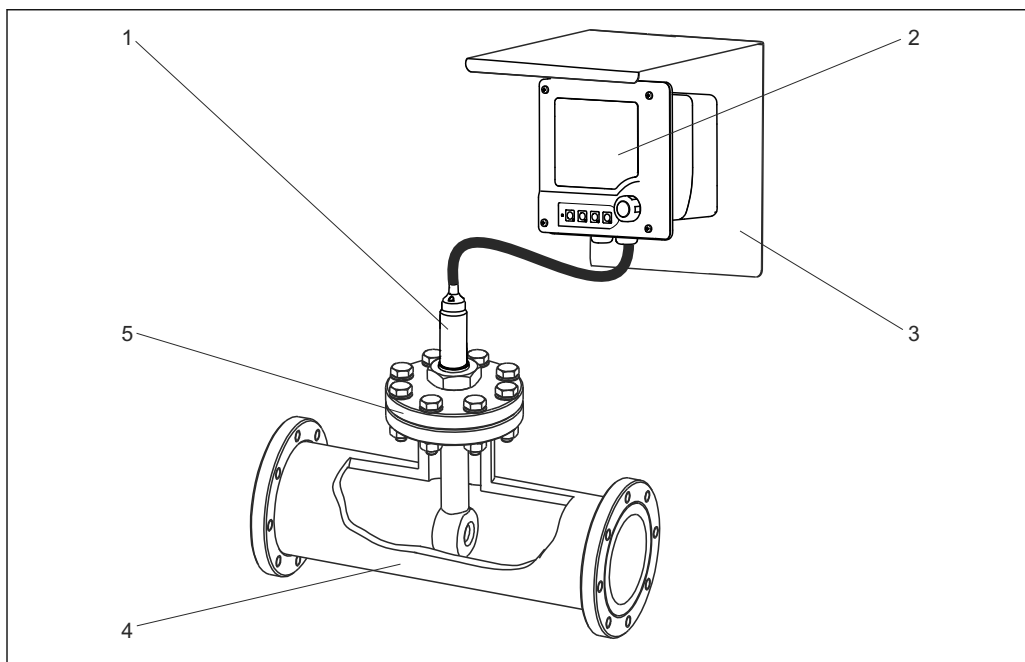

A0024930

11 Example of a measuring system

- 1 CLS50 sensor, version with lap joint flange and fixed cable with ferrules
- 2 Liquiline CM42 transmitter
- 3 Protective cover
- 4 Pipe
- 5 Pipe nozzle with flange connection

Communication and data processing (CLS50D only)

Communication with the transmitter

Always connect digital sensors with Memosens technology to a transmitter with Memosens technology. Data transmission to a transmitter for analog sensors is not possible.

Digital sensors are able to store the following system data in the sensor:

- Manufacturing data
 - Serial number
 - Order code
 - Date of manufacture
- Calibration data
 - Calibration date
 - Cell constant
 - Delta cell constant
 - Calibration values
 - Number of calibrations
 - Serial number of the transmitter used for the last calibration
- Application data
 - Temperature application range
 - Conductivity application range
 - Date of first commissioning
 - Maximum temperature value
 - Hours of operation under extreme conditions
 - Hours of operation at high temperatures

COS51D function and system design

Measuring principle

The oxygen molecules that diffuse through the membrane are reduced at the cathode to hydroxide ions (OH⁻). At the anode, silver is oxidized into silver ions (Ag⁺) (this forms a silver halide layer). A current flows due to the electron donation at the cathode and the electron acceptance at the anode. Under constant conditions, this flow is proportional to the oxygen content of the medium. This current is converted in the transmitter and indicated on the display as an oxygen concentration in mg/l, µg/l, ppm, ppb or Vol%, as a saturation index in % SAT or as an oxygen partial pressure in hPa.

Potentiostatic-amperometric three-electrode system

The high-impedance, current-free reference electrode plays an important role. The formation of a silver bromide or silver chloride coating on the anode uses up the bromide or chloride ions dissolved in the electrolyte. In the case of conventional membrane-covered sensors working with the two-electrode system, this causes an increase in signal drift. This is not the case with the three-electrode system: The change in bromide or chloride concentration is registered by the reference electrode and an internal control circuit keeps the working electrode potential constant. The advantages of this principle are significantly higher signal accuracy and considerably longer calibration intervals.

Memosens technology

Maximum process safety

With inductive transmission of the measured value using a non-contact connection, Memosens guarantees maximum process safety and offers the following benefits:

- All problems caused by moisture are eliminated:
 - Plug-in connection free from corrosion
 - Measured values cannot be distorted by moisture
 - Can even be connected under water
- Transmitter is galvanically decoupled from the medium
- EMC safety guaranteed by screening measures in digital measured value transmission
- Intrinsically safe electronics mean operation in hazardous areas is not a problem

Data security thanks to digital data transmission

Memosens technology digitizes the measured values in the sensor and transmits the data to the transmitter via a non-contact connection that is free from potential interference. The result:

- Automatic error message if sensor fails or connection between sensor and transmitter is interrupted
- Immediate error detection increases measuring point availability

Easy to use

Sensors with Memosens technology have an integrated electronics unit that stores calibration data and other information (such as total operating hours, operating hours under extreme measuring conditions). When the sensor is installed, the sensor data are transferred automatically to the transmitter and used to calculate the current measured value.

As the calibration data are stored in the sensor, the sensor can be calibrated independently of the measuring point. The result:

- Easy calibration in the measuring lab under optimum external conditions increases the quality of the calibration
- Pre-calibrated sensors can be replaced quickly and easily, resulting in a dramatic increase in measuring point availability
- Installation of the transmitter in the measuring container with integrated measuring devices reduces the cabling work and fastening fixtures required
- Thanks to the availability of the sensor data, maintenance intervals can be accurately defined and predictive maintenance is possible
- Sensor history can be documented on external data carriers and in evaluation programs
- The application of the sensor can be determined based on its previous history

Measuring system

A complete measuring system comprises:

- Digital oxygen sensor Oxymax COS51D
- Transmitter, e.g. Liquiline CM42
- Measuring cable CYK10
- Assembly, e.g. immersion assembly CYA112 or retractable assembly COA451

Optional (see Accessories):

- Assembly holder CYH1112 for immersion operation
- RM junction box (for cable extension)
- Automatic cleaning system Chemoclean with spray head

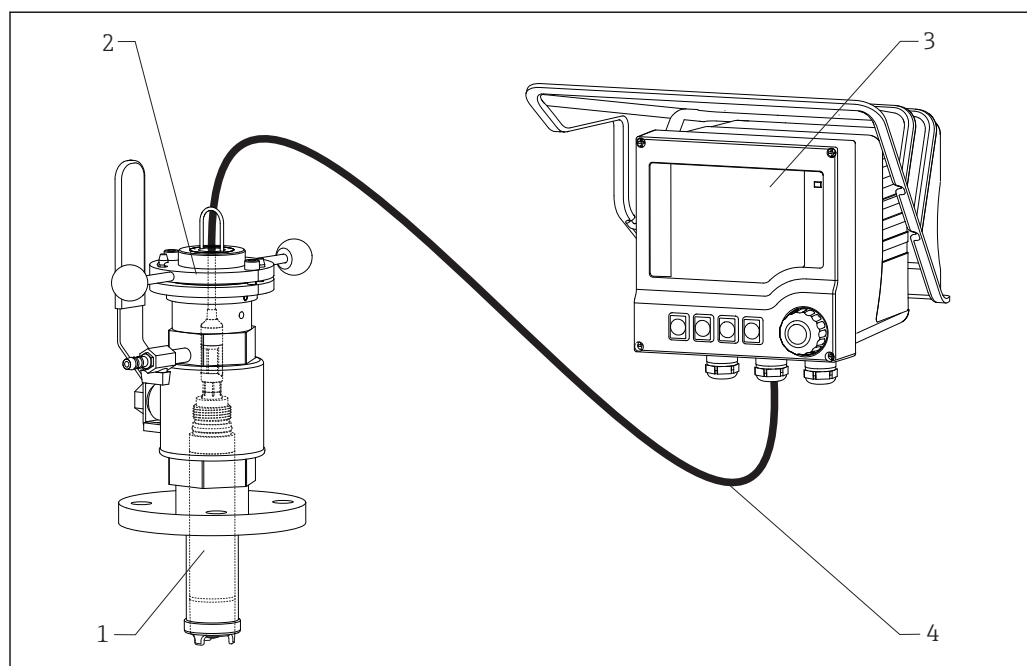



A0006735

12 Example of a measuring system

- 1 Digital oxygen sensor Oxymax COS51D
- 2 Retractable assembly COA451
- 3 Liquiline CM42
- 4 Measuring cable CYK10

CYA112 function and system design

 For detailed information on the "function and system design of Flexdip CYA112", see the Technical Information →  50

Power supply

SGC400 power supply

Supply voltage

Voltage	100 to 240 V _{AC}
Current consumption	0.07 A
Power consumption	15 W
Electrical connection	Terminal X1 (green/yellow): PE Terminal X2 (blue): N Terminal X3 (gray): L1

CM444 power supply

Supply voltage

CM442

Depending on version:

- 100 to 230 V AC, 50/60 Hz
Maximum permitted fluctuation of mains supply voltage: $\pm 15\%$ of nominal voltage
- 24 V AC/DC, 50/60 Hz
Maximum permitted fluctuation of mains supply voltage: $+ 20\% - 15\%$ of nominal voltage

CM444 and CM448

Depending on the version,:

- 100 to 230 V AC, 50/60 Hz
Maximum permitted fluctuation of mains supply voltage: $\pm 15\%$ of nominal voltage
- 24 V DC
Maximum permitted fluctuation of mains supply voltage: $+ 20\% - 15\%$ of nominal voltage

NOTICE

The device does not have a power switch!

- ▶ Provide a protected circuit breaker in the vicinity of the device at the place of installation.
- ▶ The circuit breaker must be a switch or power switch, and must be labeled as the circuit breaker for the device.
- ▶ At the supply point, the power supply must be isolated from dangerous live cables by double or reinforced insulation in the case of devices with a 24 V supply voltage.

Fieldbus connection

Supply voltage: not applicable

Power consumption

CM442

Depending on supply voltage

- 100 to 230 V AC and 24 V AC:
Max. 55 VA
- 24 V DC:
Max. 22 W

CM444 and CM448

Depending on supply voltage

- 100 to 230 V AC:
Max. 73 VA
- 24 V DC:
Max. 68 W

Fuse

Fuse not exchangeable

Overvoltage protection

Integrated overvoltage/lightning protection as per EN 61326
Protection category 1 and 3

Cable entries

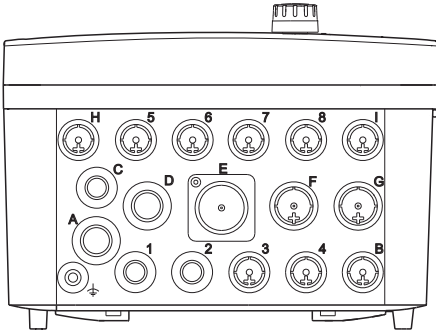
Identification of the cable entry on housing base	Suitable gland
B, C, H, I, 1-8	M16x1.5 mm/NPT3/8"/G3/8
A, D, F, G	M20x1.5 mm/NPT1/2"/G1/2
E	-
⊕	M12x1.5 mm
 <p style="text-align: right; font-size: small;">A0018025</p>	Recommended assignment 1-8 Sensors 1-8 A Power supply B RS485 In or M12 DP/RS485 C Can be used freely D,F,G Current outputs and inputs, relays H Can be used freely I RS485 Out or M12 Ethernet E Do not use

Cable specification

Cable gland	Permitted cable diameter
M16x1.5 mm	4 to 8 mm (0.16 to 0.32")
M12x1.5 mm	2 to 5 mm (0.08 to 0.20")
M20x1.5 mm	6 to 12 mm (0.24 to 0.48")
NPT3/8"	4 to 8 mm (0.16 to 0.32")
G3/8	4 to 8 mm (0.16 to 0.32")
NPT1/2"	6 to 12 mm (0.24 to 0.48")
G1/2	7 to 12 mm (0.28 to 0.48")



Cable glands mounted at the factory are tightened with 2 Nm.

Electrical connection

Basic module

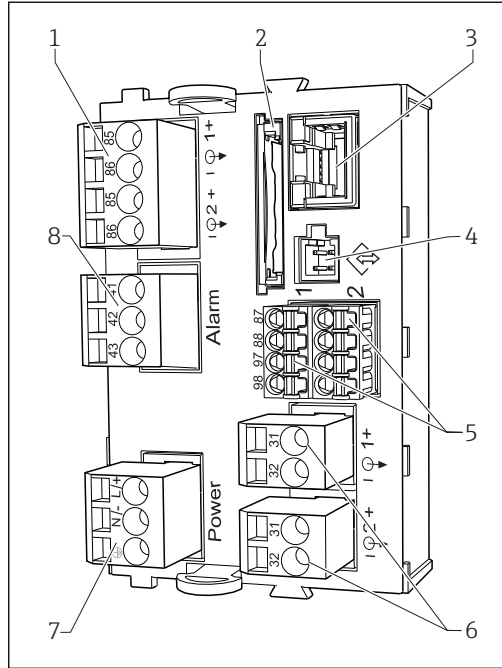

13 Basic module BASE-H or -L (two-channel device)

- 1 Power supply for digital fixed cable sensors with Memosens protocol
- 2 SD card slot
- 3 Slot for display cable ¹⁾
- 4 Service interface
- 5 Connections for 2 Memosens sensors
- 6 Current outputs
- 7 LEDs
- 8 Alarm relay connection

¹⁾ Internal device connection. Do not disconnect the plug!

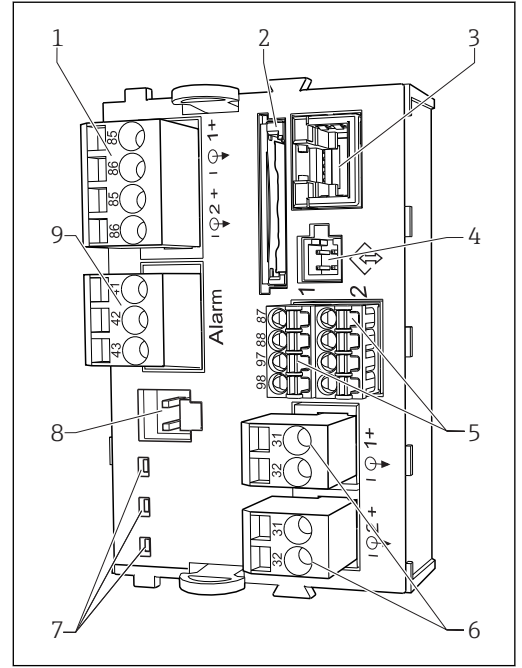

14 Basic module BASE-E (four- and eight-channel device)

- 1 Power supply for digital fixed cable sensors with Memosens protocol
- 2 SD card slot
- 3 Slot for display cable ¹⁾
- 4 Service interface
- 5 Connections for 2 Memosens sensors
- 6 Current outputs
- 7 LEDs
- 8 Socket for internal supply cable ¹⁾
- 9 Alarm relay connection

Connecting supply voltage for CM442

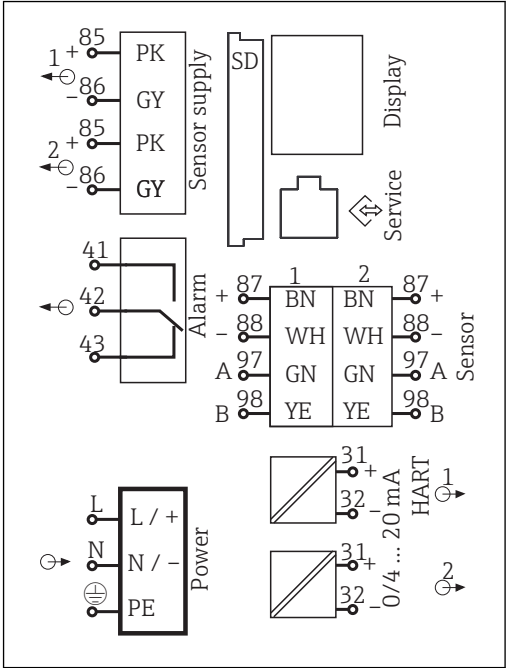
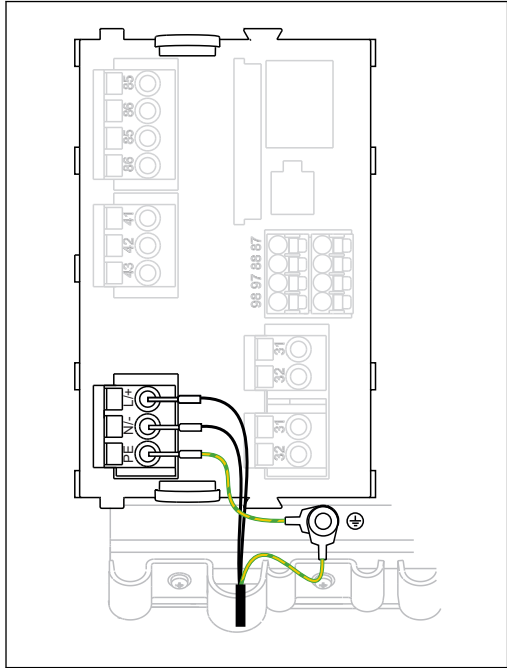

15 Connecting power supply on the BASE-H or -L

16 Overall wiring diagram for BASE-H or -L

H Power unit 100 to 230 VAC
 L Power unit 24 VAC or 24 VDC

Connecting supply voltage for CM444 and CM448

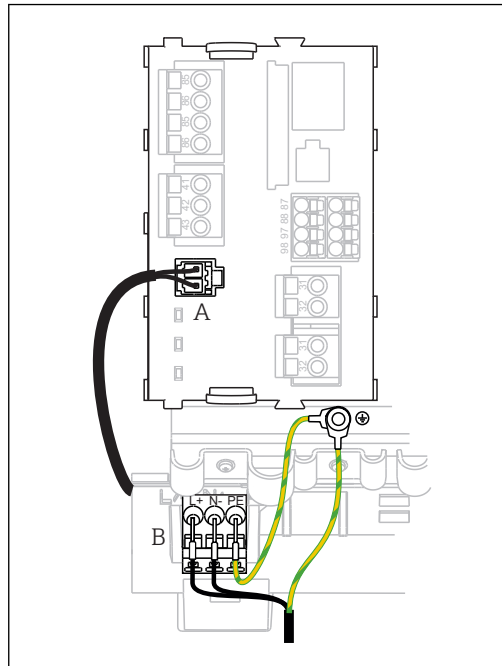

A0015872

17 Power supply connection on the BASE-E

- A Internal power supply cable
- B Extension power unit

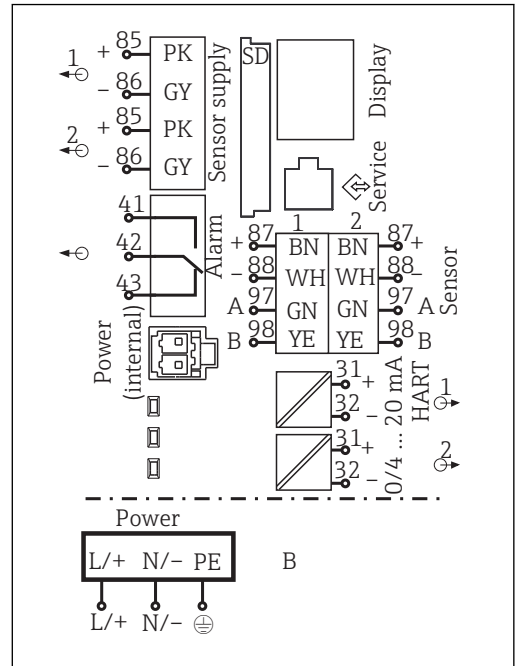

A0015873

18 Overall wiring diagram BASE-E and extension power unit (B)

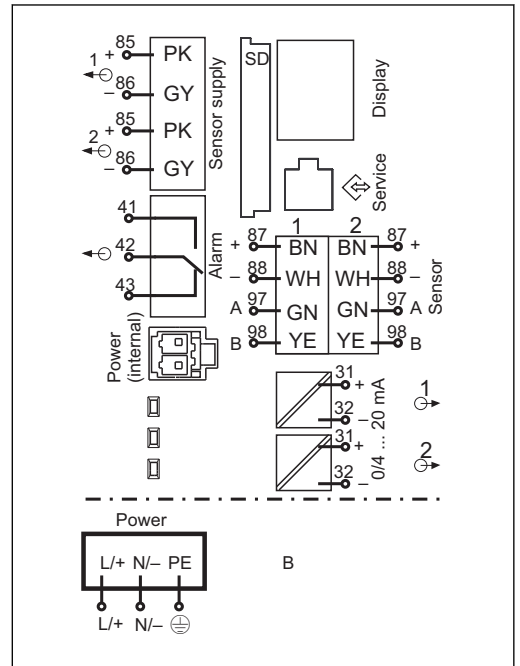

A0031391

19 Overall wiring diagram BASE-E and external power unit (B)

Connecting optional modules

With extension modules you can purchase additional functions for your device.

NOTICE

Unacceptable hardware combinations (due to conflicts in power supply)

Incorrect measurements or total failure of the measuring point as a result of heat build-up or overloading

- ▶ If you are planning to extend your controller, make sure the resulting hardware combination is permitted (Configurator at www.endress.com/CM442 or .../CM444 or .../CM448).
- ▶ Please note that if you are extending CM442 to CM444 or CM448, you must additionally fit an extension power supply unit and an extension backplane. You must then also use basic module BASE-E.
- ▶ Remember that the sum of all current inputs and outputs may not exceed 8.
- ▶ Make sure not to use more than 2 "DIO" modules. More "DIO" modules are not permitted.
- ▶ Please contact your Endress+Hauser sales center should you have any questions.

Overview of all the modules available

Module name				
AOR	2R	4R	2DS	DIO
<ul style="list-style-type: none"> ▪ 2 x 0/4 to 20 mA analog outputs ▪ 2 relays ▪ Order No. 71111053 	<ul style="list-style-type: none"> ▪ 2 relays ▪ Order No. 71125375 	<ul style="list-style-type: none"> ▪ 4 relays ▪ Order No. 71125376 	<ul style="list-style-type: none"> ▪ 2 digital sensor inputs ▪ 2 power supply systems for digital sensors ▪ Order No. 71135631 	<ul style="list-style-type: none"> ▪ 2 digital inputs ▪ 2 digital outputs with auxiliary voltage ▪ Order No. 71135638

Module name				
2AO	4AO	2AI	485	ETH
<ul style="list-style-type: none"> 2 x 0/4 to 20 mA analog outputs Order No. 71135632 	<ul style="list-style-type: none"> 4 x 0/4 to 20 mA analog outputs Order No. 71135633 	<ul style="list-style-type: none"> 2 x 0/4 to 20mA analog inputs Order No. 71135639 	<ul style="list-style-type: none"> Ethernet (web server or Modbus TCP) 5V power supply for PROFIBUS DP termination RS485 (PROFIBUS DP or Modbus RS485) Order No. 71135634 	<ul style="list-style-type: none"> Web server and Ethernet/IP or Modbus TCP Order No. 71272410



PROFIBUS DP (module 485)

Contacts 95, 96 and 99 are bridged in the connector. This ensures that PROFIBUS communication is not interrupted if the connector is disconnected.

Protective ground connection

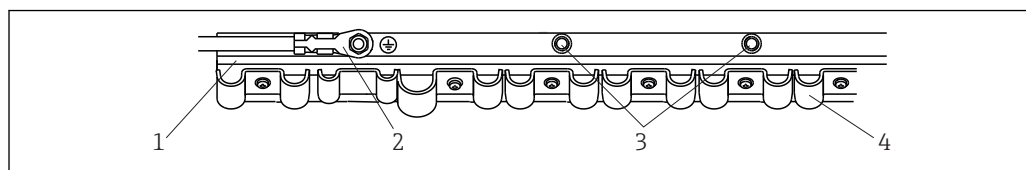

A0025171

▣ 20 Cable mounting rail and associated function

- | | |
|---|---|
| 1 Cable mounting rail | 3 Additional threaded bolts for ground connections |
| 2 Threaded bolt (protective ground connection, central grounding point) | 4 Cable clamps (fixing and grounding the sensor cables) |

Sensor connection

Sensors with Memosens protocol

Sensor types	Sensor cable	Sensors
Digital sensors without additional internal power supply	With plug-in connection and inductive signal transmission	<ul style="list-style-type: none"> ▪ pH sensors ▪ ORP sensors ▪ Combined sensors ▪ Oxygen sensors (amperometric and optical) ▪ Conductivity sensors with conductive measurement of conductivity ▪ Chlorine sensors (disinfection)
	Fixed cable	Conductivity sensors with inductive measurement of conductivity
Digital sensors with additional internal power supply	Fixed cable	<ul style="list-style-type: none"> ▪ Turbidity sensors ▪ Sensors for interface measurement ▪ Sensors for measuring the spectral absorption coefficient (SAC) ▪ Nitrate sensors ▪ Optical oxygen sensors ▪ Ion-sensitive sensors

The following rule applies if connecting CUS71D sensors:

- CM442
 - Only one CUS71D is possible; an additional sensor is not permitted.
 - The second sensor input may also not be used for another type of sensor.
- CM444
 - No restrictions. All the sensor inputs can be used as required.
- CM448
 - If a CUS71D is connected, the number of sensor inputs that can be used is limited to a maximum of 4.
 - Of these, all 4 inputs can be used for CUS71D sensors.
 - Every combination of CUS71D and other sensors is possible, provided that the total number of connected sensors does not exceed 4.

Types of connection

- Direct connection of sensor cable to terminal connector of the sensor module 2DS or of base module L, H or E (→ ▣ 21 ff.)
- Optional: Sensor cable plug connected to the M12 sensor socket on the underside of the device
With this type of connection, the device is already wired at the factory (→ ▣ 24).

Sensor cable connected directly

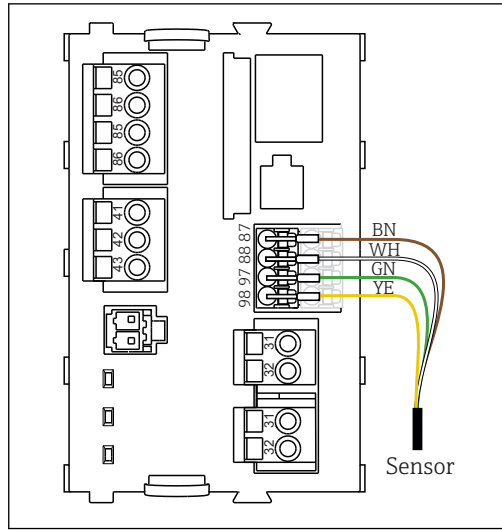

A0023038

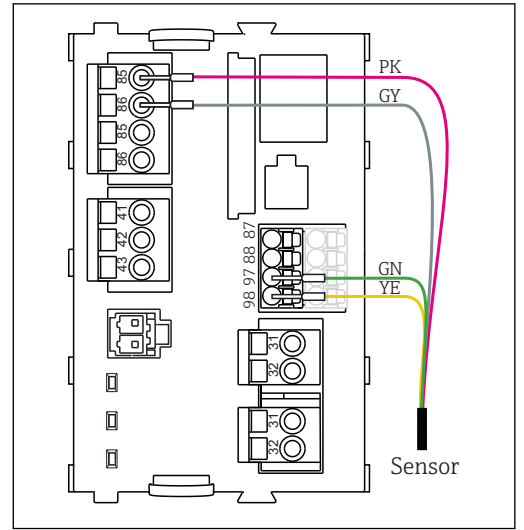

A0023039

21 sensors without additional supply voltage

22 sensors with additional supply voltage

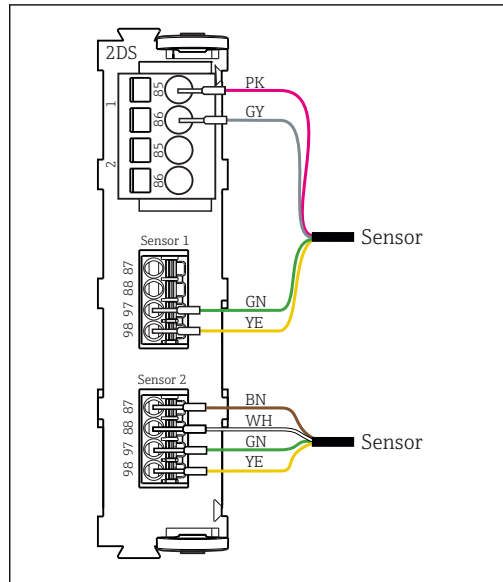

A0033206

23 sensors with and without additional supply voltage at sensor module 2DS

connection via M12 plug-in connection

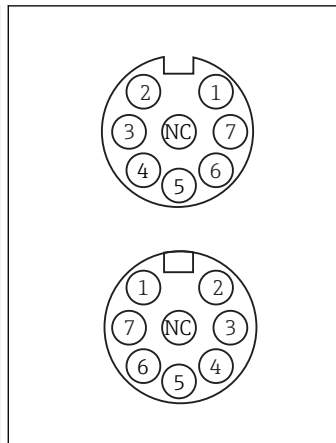
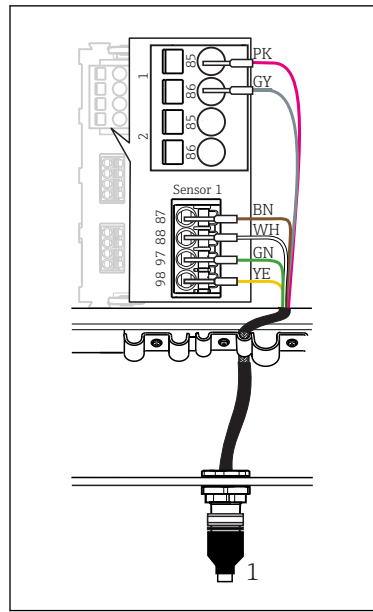

Device versions with a pre-installed M12 socket are ready-wired upon delivery.

Please note the following:

- The internal device wiring is always the same regardless of what kind of sensor you connect to the M12 socket (plug&play).
- The signal or power supply cables are assigned in the sensor head in such a way that the PK and GY power supply cables are either used (e.g. optical sensors) or not (e.g. pH or ORP sensors).

25 M12 assignment Top: socket
Bottom: connector (top view
in each case)

- 1 PK (24 V)
- 2 GY (Ground 24 V)
- 3 BN (3 V)
- 4 WH (Ground 3 V)
- 5 GN (Memosens)
- 6 YE (Memosens)
- 7, Not connected
- NC

24 M12 plug-in connection (e.g. at
sensor module)

- 1 Sensor cable with M12 connector

CPF81D power supply

Electrical connection

The electrical connection of the sensor to the transmitter takes place via special measuring cable CYK10 or CYK20.

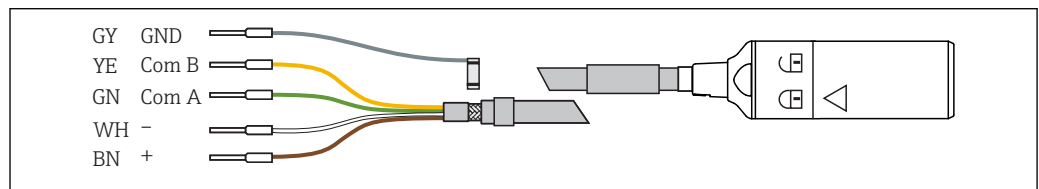

26 Measuring cable CYK10/CYK20

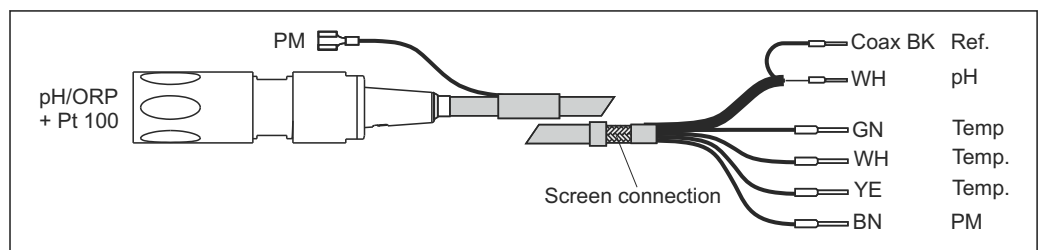

27 Measuring cable CPK9

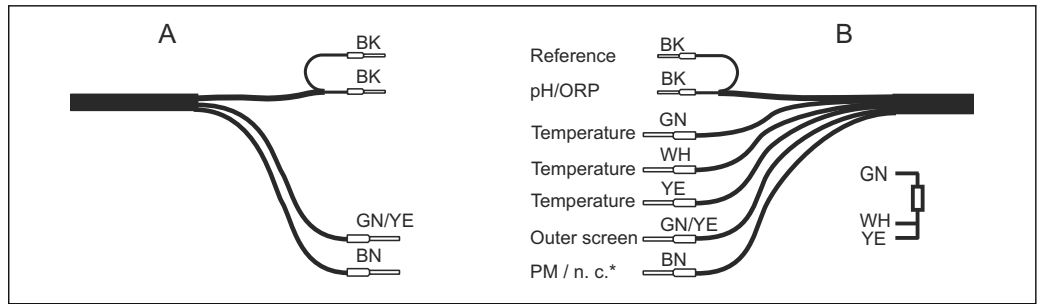

28 Fixed cable connection

A Fixed cable CPF81 without temperature sensor and CPF82

B Fixed cable CPF81 with temperature sensor

* The PML is connected only in the case of sensor versions with an internal PML (CPF81-xxx2xx)

CLS50D power supply

Electrical connection

The sensor is supplied with a fixed cable. The cable between the sensor and transmitter can be extended using the CYK11 (CLS50D) or CLK6 (CLS50) special measuring cable (does not apply for use in a hazardous environment).

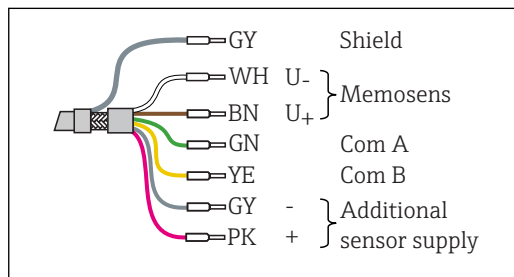

29 CYK11 for extension for CLS50D

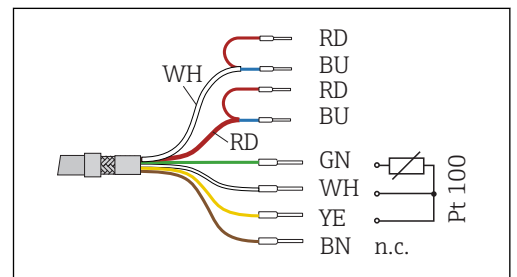

30 CLK6 for extension for CLS50

Max. total cable length: 100 m (330 ft)

Max. total cable length: 55 m (180 ft)



CLS50 only:

The residual coupling of the sensor increases when the fixed cable is extended.

Performance characteristics

SGC400 performance characteristics

Hardware

CPU	BCM2837, 1.2 GHz, quad-core
Ports	2x Ethernet Modbus TCP

Software

Operating system	Raspbian version Jessie incl. RT patch
Standard software	Endress+Hauser-specific runtime environment

CM444 performance characteristics

Response time

Current outputs

t₉₀ = max. 500 ms for an increase from 0 to 20 mA

Current inputs

t₉₀ = max. 330 ms for an increase from 0 to 20 mA

Digital inputs and outputs

t₉₀ = max. 330 ms for an increase from low to high

Reference temperature

25 °C (77 °F)

Measured error for sensor inputs

→ Documentation of the connected sensor

Measured error for current inputs and outputs**Typical measured errors:**

< 20 µA (with current values < 4 mA)

< 50 µA (with current values 4 to 20 mA)

at 25 °C (77 °F) each

Additional measured error depending on the temperature:

< 1.5 µA/K

Frequency tolerance of digital inputs and outputs

≤ 1%

Resolution of current inputs and outputs

< 5 µA

Repeatability

→ Documentation of the connected sensor

CLS50D performance characteristics**Conductivity response time** $t_{95} \leq 2 \text{ s}$ **Temperature response time**

PEEK version:

 $t_{90} \leq 7 \text{ min}$

PFA version:

 $t_{90} \leq 11 \text{ min}$ **Maximum measured error**

-20 to 100 °C (-4 to 212 °F):

 $\pm(5 \mu\text{S}/\text{cm} + 0.5 \% \text{ of reading})$

> 100 °C (212 °F):

 $\pm(10 \mu\text{S}/\text{cm} + 0.5 \% \text{ of reading})$ **Repeatability**

0.2% of reading

Linearity

1.9 % (only applies in the 1 to 20 mS/cm measuring range)

COS51D performance characteristics**Response time**

COS51D-***0* (black membrane cap for standard response time):

■ t_{90} : 3 minutes■ t_{98} : 8 minutes (at 20 °C (68 °F) in each case)

COS51D-***1* (white membrane cap for fast response time):

■ t_{90} : 0.5 minutes■ t_{98} : 1.5 minutes (at 20 °C (68 °F) in each case)**Reference operating conditions**

Reference temperature: 25 °C (77 °F))

Reference pressure: 1013 hPa (15 psi)

Signal current in air¹⁾

- COS51D-***0* (black membrane cap): approx. 300 nA
- COS51D-***1* (white membrane cap): approx. 1100 nA

Zero current

< 0.1 % of the current in air

Measured value resolution

0.01 mg/l (0.01 ppm)

0.001 mg/l (0.001 ppm)

Maximum measured error

±1 % of the measured value²⁾

Repeatability

±1% of reading

Long-term drift

Zero-point drift: < 0.1 % per week at 30 °C (86 °F)

Measuring range drift: < 0.1 % per week at 30 °C (86 °F)³⁾

Influence of the medium pressure

Pressure compensation not required

Polarization time

< 60 minutes

Intrinsic oxygen consumption

COS51D-***0*: approx. 90 ng/h in air at 25 °C (77 °F)

COS51D-***1*: approx. 270 ng/h in air at 25 °C (77 °F)

Installation



For detailed information on the "Smart System for Surface Water SSP100", see the Operating Instructions → 50

Environment

SGC400 environment

Ambient temperature range

-25 to 55 °C (-13 to 131 °F)

Storage temperature

-40 to 80 °C (-40 to 176 °F)

Humidity

10 to 90 % (non-condensing)

1) At the specified reference operating conditions
2) In accordance with IEC 60746-1 at rated operating conditions
3) Under constant conditions in each case

Degree of protection

IP54

Shock resistance

LTE modem Teltonika RUT240 (IEC 60950-1:2005, EN 60950-1:2006)

Kunbus RevPi 3 (EN 61131-2)

Phoenix Contact UNO-PS (IEC 60068-2-27, IEC 60068-2-6)

Electromagnetic compatibility (EMC)

Complies with EMC Directive 2014/30/EU

LTE modem Teltonika RUT240 (EN61000-4)

Kunbus RevPi Core 3 (EN 61131-2, IEC 61000-6-2)

Phoenix Contact UNO-PS (EN 61000-4)

CM444 environment**Ambient temperature range****CM444**

- Generally -20 to 55 °C (0 to 130 °F), with the exception of packages under the second point in the list

- -20 to 50 °C (0 to 120 °F) for the following packages:

- CM444-**M40A7FI*****+...
- CM444-**M40A7FK*****+...
- CM444-**N40A7FI*****+...
- CM444-**N40A7FK*****+...
- CM444-**M4AA5F4*****+...
- CM444-**M4AA5FF*****+...
- CM444-**M4AA5FH*****+...
- CM444-**M4AA5FI*****+...
- CM444-**M4AA5FK*****+...
- CM444-**M4AA5FM*****+...
- CM444-**M4BA5F4*****+...
- CM444-**M4BA5FF*****+...
- CM444-**M4BA5FH*****+...
- CM444-**M4BA5FI*****+...
- CM444-**M4BA5FK*****+...
- CM444-**M4BA5FM*****+...
- CM444-**M4DA5F4*****+...
- CM444-**M4DA5FF*****+...
- CM444-**M4DA5FH*****+...
- CM444-**M4DA5FI*****+...
- CM444-**M4DA5FK*****+...
- CM444-**M4DA5FM*****+...

Storage temperature

-40 to +80 °C (-40 to 175 °F)

Humidity

10 to 95 %, non-condensating

Degree of protection

IP 66/67, impermeability and corrosion resistance in accordance with NEMA TYPE 4X

Vibration resistance**Environmental tests**

Vibration test based on DIN EN 60068-2, October 2008

Vibration test based on DIN EN 60654-3, August 1998

Post or pipe mounting

Frequency range	10 to 500 Hz (sinusoidal)	
Amplitude	10 to 57.5 Hz:	0.15 mm
	57.5 to 500 Hz:	2 g ¹⁾
Test duration	10 frequency cycles/ spatial axis, in 3 spatial axes (1 oct./min)	

Wall mounting

Frequency range	10 to 150 Hz (sinusoidal)	
Amplitude	10 to 12.9 Hz:	0.75 mm
	12.9 to 150 Hz:	0.5 g ¹⁾
Test duration	10 frequency cycles/ spatial axis, in 3 spatial axes (1 oct./min)	

1) g ... gravitational acceleration (1 g ≈ 9.81 m/s²)

Electromagnetic compatibility

Interference emission and interference immunity as per EN 61326-1:2013, Class A for Industry

Electrical safety

IEC 61010-1, Class I equipment
 Low voltage: overvoltage category II
 Environment < 3000 m (< 9840 ft) above MSL

Degree of contamination

The product is suitable for pollution degree 4.

Pressure compensation to environment

Filter made of GORE-TEX used as pressure compensation element
 Ensures pressure compensation to environment and guarantees IP protection.

CPF81D environment

Ambient temperature range

NOTICE

Danger of frost damage

► The sensor must not be used at temperatures below 0 °C (32 °F).

Storage temperature

0 to 50 °C (32 to 120 °F)

Degree of protection

CPF81D, CPF82D

IP 68 (10 m (33 ft) head of water at 25 °C (77 °F) over 45 days, 1 mol/l KCl)

CPF81, CPF82 with TOP68 plug-in head

IP 68 (1 m (3.3 ft) water column, 50 °C (122 °F), 168 h)

CPF81, CPF82 with fixed cable

IP 67

Electromagnetic compatibility

Interference emission and interference immunity in accordance with EN 61326-1:2006, EN 61326-2-3:2006

Memosens versions
 for ESD > 8 kV: reduced accuracy ±1.5 pH

CLS50D environment

Ambient temperature range

CLS50D

-10 to +60 °C (+10 to +140 °F)

Storage temperature
-20 to +80 °C (0 to 180 °F)

Degree of protection
IP 68 / NEMA type 6 (sensor in installed state with genuine seal)

COS51D environment

Ambient temperature range
-5 to 50 °C (20 to 120 °F)

Storage temperature
Filled with electrolyte: -5 to 50 °C (20 to 120 °F)
Without electrolyte: -20 to 60 °C (0 to 140 °F)

Degree of protection
IP 68 (testing conditions: 10 m (33 ft) water column at 25 °C (77 °F) over 30 days)

CYA112 environment

Air temperature
-20 to 60 °C (-4 to 140 °F)

Mechanical construction

SGC400 mechanical construction

Design, dimensions
Mounting plate
190 mm · 125 mm · 3 mm (7.48 in · 4.92 in · 0.12 in)

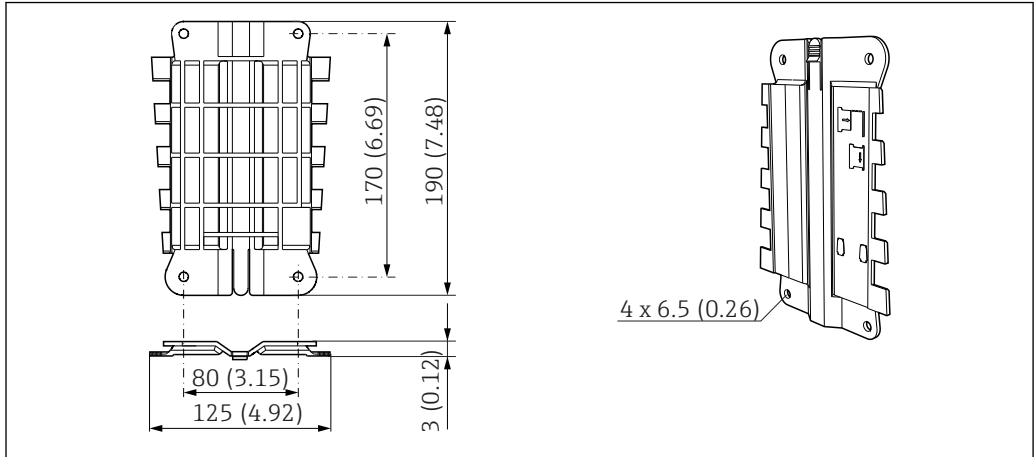

31 Dimensions of mounting plate

Modbus Edge Device SCG400
237 mm · 194 mm · 162 mm (9.33 in · 7.64 in · 6.38 in)

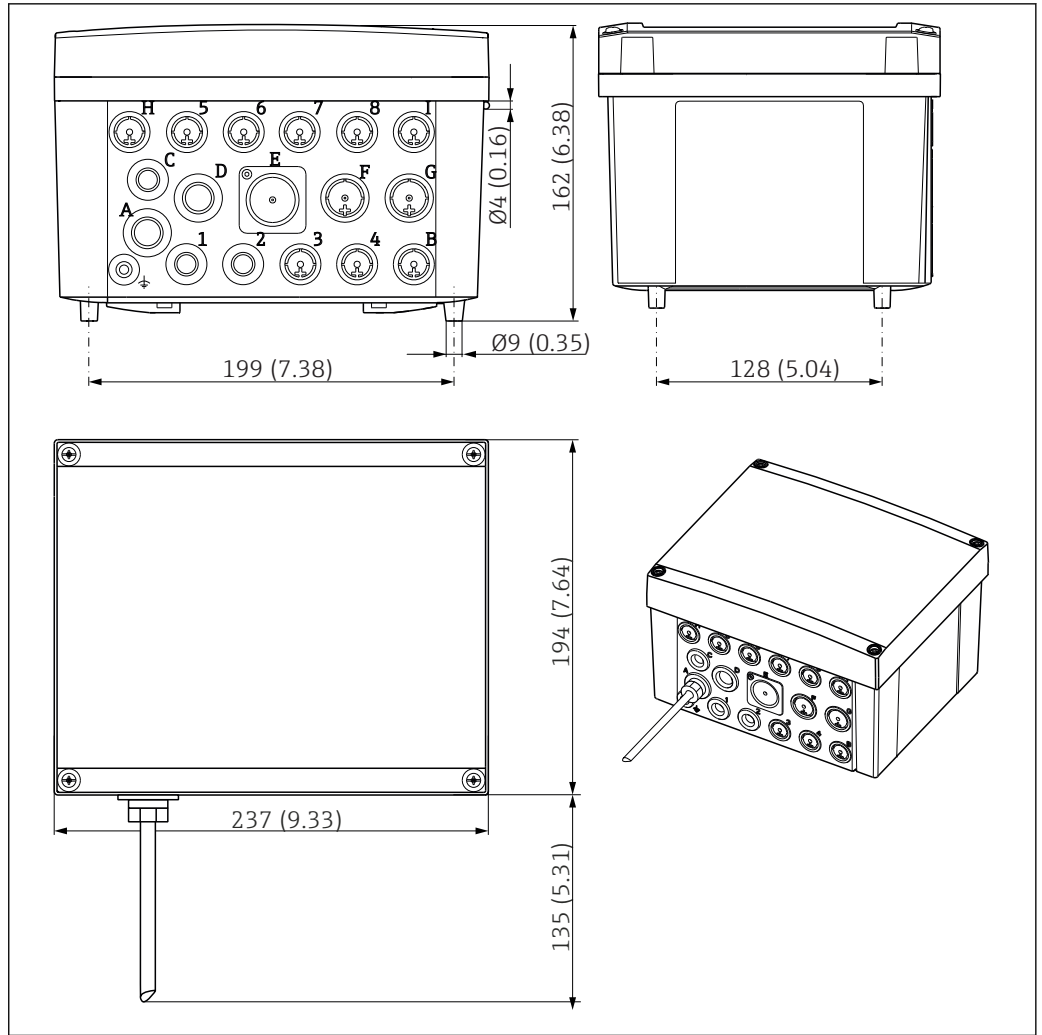

32 Dimensions of Modbus Edge Device SCG400 with LTE antenna

Weight

2.3 kg (5.08 lb)

Materials

Housing	PC-FR
Seal	EPDM
Carrier board	Stainless steel 1.4301, AISI304
Cable entries	Polyamide V0 as per UL94

CM444 mechanical construction

Dimensions

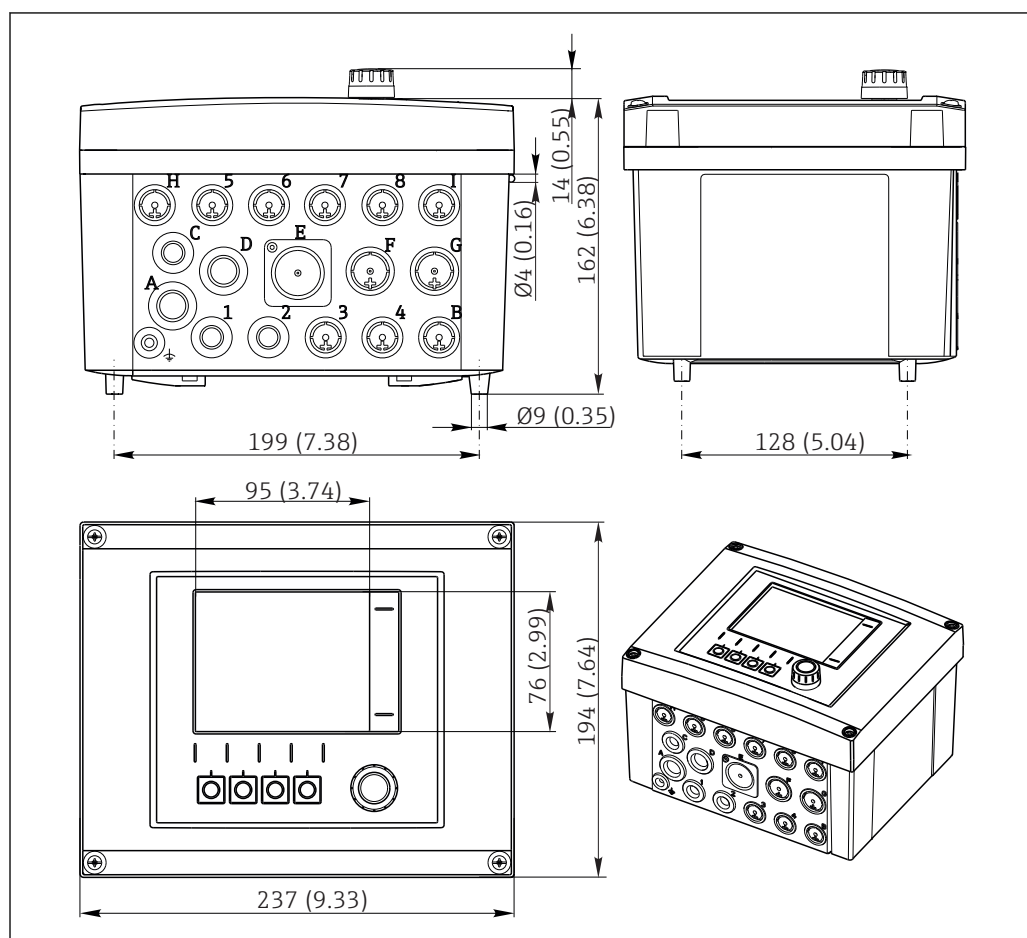

A0012396

33 Dimensions of field housing in mm (inch)

Weight

Complete device	Approx. 2.1 kg (4.63 lbs), depending on the version
Individual module	Approx. 0.06 kg (0.13 lbs)
SD card	Max. 5 g (0.17 oz)

Materials

Housing base	PC-FR
Display cover	PC-FR
Display foil and soft keys	PE
Housing seal	EPDM
Module side panels	PC-FR
Module covers	PBT GF30 FR
Cable mounting rail	PBT GF30 FR, stainless steel 1.4301 (AISI304)
Clamps	Stainless steel 1.4301 (AISI304)
Threaded fasteners	Stainless steel 1.4301 (AISI304)
Cable glands	Polyamide V0 as per UL94

CPF81D mechanical construction

Design, dimensions

CPF81D, CPF82D

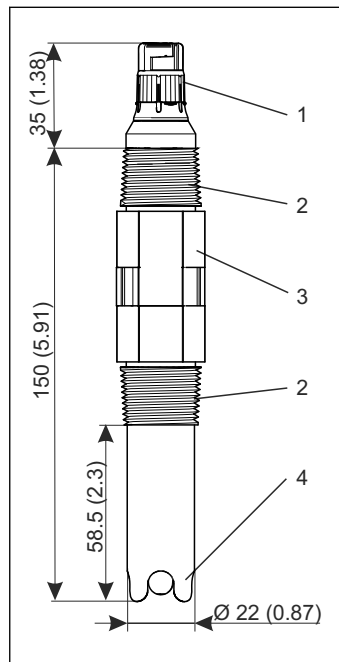

A0024672

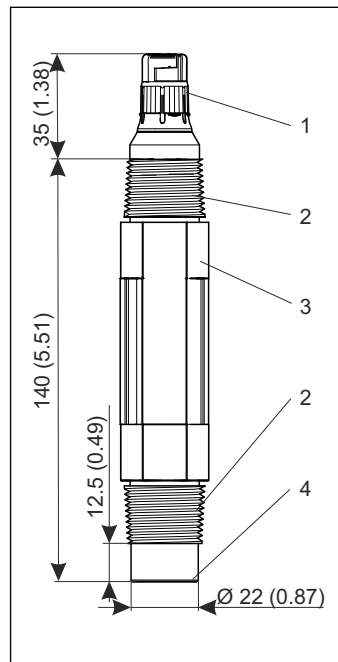

A0024671

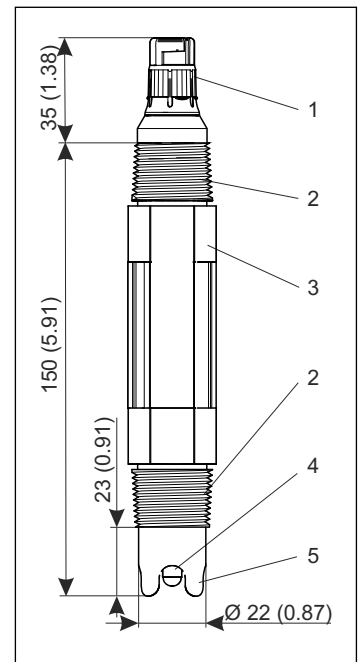

A0024673

▣ 34 CPF81D, long shaft, protection guard

- 1 Memosens plug-in head
- 2 NPT 3/4" thread
- 3 Across flats AF 26
- 4 Protection guard

▣ 35 CPF81D, flat membrane

- 1 Memosens plug-in head
- 2 NPT 3/4" thread
- 3 Across flats AF 26
- 4 Flat membrane

▣ 36 CPF82D, short shaft, protection guard

- 1 Memosens plug-in head
- 2 NPT 3/4" thread
- 3 Across flats AF 26
- 4 Platinum ring
- 5 Protection guard

Dimensions in mm (inch)

Weight

0.12 to 0.15 kg (0.26 to 0.33 lbs, depending on version and without cable)

Materials

Housing, electrode shaft	PPS
pH electrode (in contact with medium)	Lead-free membrane glass, suitable for process applications
ORP electrode (in contact with medium):	Platinum ring
Double chamber reference system:	KNO ₃ and KCl/AgCl

Process connection

NPT 3/4"

Integrated preamplifier (optional)

Structure	cast in sensor body
Power supply	via integrated coin cells
Reference potential:	reference electrode

i With preamplifier versions, the sensor check function (SCS) of the transmitter is ineffective and should be turned off.

CLS50D mechanical construction

Dimensions

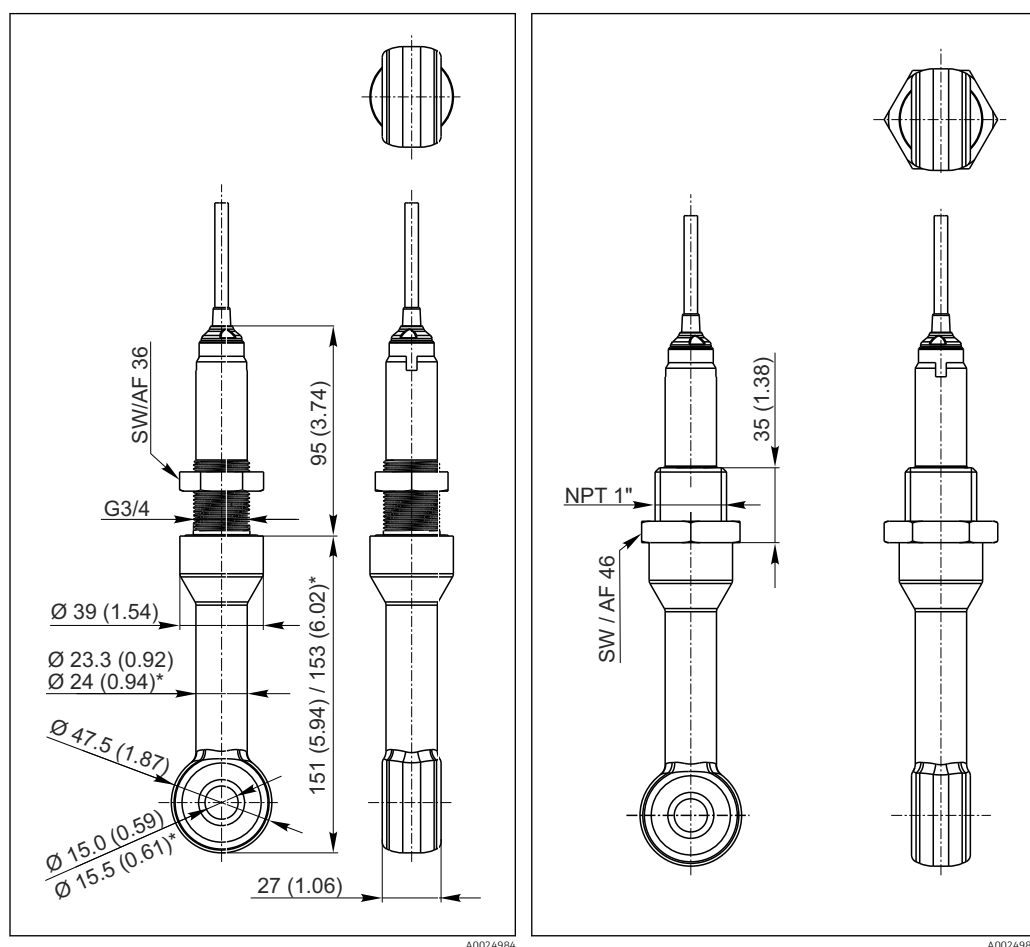

37 Version with G $\frac{3}{4}$ thread, dimensions in mm (inch)

38 Version with NPT 1" thread, dimensions in mm (inch)

* Dimension for PEEK version

Weight

Approx. 0.65 kg (1.43 lbs)

Materials

Sensor	PEEK, PFA (depending on version)
Sensor seal	VITON, CHEMRAZ (depending on version)
Process connections	
G $\frac{3}{4}$	CLS50-**A: stainless steel 1.4571 (AISI 316Ti) CLS50-**B/C: PEEK GF30 CLS50D-**D: stainless steel 1.4571 (AISI 316Ti) CLS50D-**B/C: PEEK GF30
NPT 1"	PEEK
Fixed flange	Stainless steel 1.4404 (AISI 316L)
Sealing disk	GYLON (PTFE ceramic-filled)
Lap joint flange	PP-GF
Flange combined with lap joint flange	PVDF

Process connections

- G $\frac{3}{4}$ thread
- NPT 1" thread
- Lap joint flange EN 1092 DN50 PN10
- Lap joint flange ANSI 2" 150 lbs
- Lap joint flange JIS 10K 50A
- Flange EN 1092-1 DN50 PN16
- Flange ANSI 2" 300 lbs
- Flange JIS 10K 50A

Chemical resistance

Medium	Concentration	PEEK	PFA	CHEMRAZ	VITON
Sodium hydroxide solution NaOH	0 to 50 %	20 to 100 °C (68 to 212 °F)	Not suitable	0 to 150 °C (32 to 302 °F)	Not suitable
Nitric acid HNO ₃	0 to 10 %	20 to 100 °C (68 to 212 °F)	20 to 80 °C (68 to 176 °F)	0 to 150 °C (32 to 302 °F)	0 to 120 °C (32 to 248 °F)
	0 to 40 %	20 °C (68 °F)	20 to 60 °C (68 to 140 °F)	0 to 150 °C (32 to 302 °F)	0 to 120 °C (32 to 248 °F)
Phosphoric acid H ₃ PO ₄	0 to 80 %	20 to 100 °C (68 to 212 °F)	20 to 60 °C (68 to 140 °F)	0 to 150 °C (32 to 302 °F)	0 to 120 °C (32 to 248 °F)
Sulfuric acid H ₂ SO ₄	0 to 2.5 %	20 to 80 °C (68 to 176 °F)	20 to 100 °C (68 to 212 °F)	0 to 150 °C (32 to 302 °F)	0 to 120 °C (32 to 248 °F)
	0 to 30 %	20 °C (68 °F)	20 to 100 °C (68 to 212 °F)	0 to 150 °C (32 to 302 °F)	0 to 120 °C (32 to 248 °F)
Hydrochloric acid HCl	0 to 5 %	20 to 100 °C (68 to 212 °F)	20 to 80 °C (68 to 176 °F)	0 to 150 °C (32 to 302 °F)	0 to 120 °C (32 to 248 °F)
	0 to 10 %	20 to 100 °C (68 to 212 °F)	20 to 80 °C (68 to 176 °F)	0 to 150 °C (32 to 302 °F)	0 to 120 °C (32 to 248 °F)

COS51D mechanical construction**Design, dimensions**

For detailed information on "Oxymax COS51D", see the Technical Information → 50

Weight

0.3 kg (0.7 lb)

Materials

Sensor shaft: POM

Membrane cap: POM

Cathode: gold

Anode/reference electrode: silver/silver bromide

Process connection

G1 and NPT $\frac{3}{4}$ "

Membrane thickness

COS51D-***0*: approx. 50 μ m

Temperature compensation

Internal

Electrolyte

Alkaline saline solution

CYA112 mechanical construction**Dimensions**

Immersion tube (PVC): Ø 40 mm (1.57 in), length: 600 mm (23.6")

Weight

Immersion tube (PVC) (length 1): 0.3 kg (0.7 lb)

Multifunctional clamp ring: 0.15 kg (0.33 lb)

Weight for PVC immersion tube: 0.32 kg (0.71 lb)

Materials

Sensor adaption: POM - GF

Quick release fastener: POM - GF

Multifunctional clamp ring: POM - GF

Cap for tube end: PE

Chain bracket: stainless steel 1.4571 (AISI 316 Ti) or 1.4404 (AISI 316 L)

O-rings: EPDM

Sensors

Sensors from Endress+Hauser

Sensor	Preferred assembly material ¹⁾	Connection angle	Connection thread	Suitable for quick release fastener
CPF8x/8xD	PVC	0°	NPT ¾"	Yes
COS51D	PVC	0°	G1	Yes
CLS50/50D	PVC, stainless steel	0°	G¾	Yes

1) Use stainless steel for the hazardous area

Sensors by connection thread

Sensor with connection thread	Preferred assembly material	Connection angle	Adapter	Suitable for quick release fastener
NPT ¾"	PVC	0°/45°	NPT ¾"	Yes
G1	PVC, stainless steel	0°/ 45°/90°	G1	Yes
G¾	PVC, stainless steel	0°	G¾	Yes

Sensor adapter

For detailed information on the "Flexdip CYA112 sensor adapter", see the Technical Information → 50

Operability

CM444 operability**display**

Graphic display:

- Resolution: 240 x 160 pixel
- Back light with switch-off function
- Red display background for alarms alerts users to errors
- Transflective display technology for maximum contrast even in bright environments
- User-definable measuring menus mean you can always keep track of the values that are important for your application.

Operating concept

The simple and structured operating concept sets new standards:

- Intuitive operation with the navigator and soft keys
- Fast configuration of application-specific measurement options
- Easy configuration and diagnosis thanks to plain-text display
- All languages that can be ordered are available in every device



39 Easy operation

40 Plain-text menu

Local operation

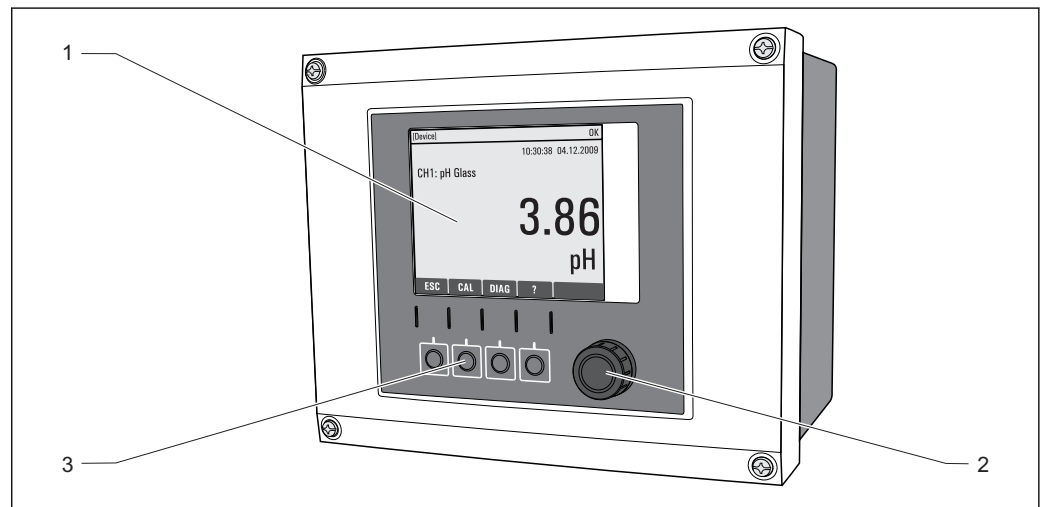

41 Overview of operation

- 1 Display (with red display background in alarm condition)
- 2 Navigator (jog/shuttle and press/hold function)
- 3 Soft keys (function depends on menu)

Remote operation

Via HART (e.g. using HART modem and FieldCare)

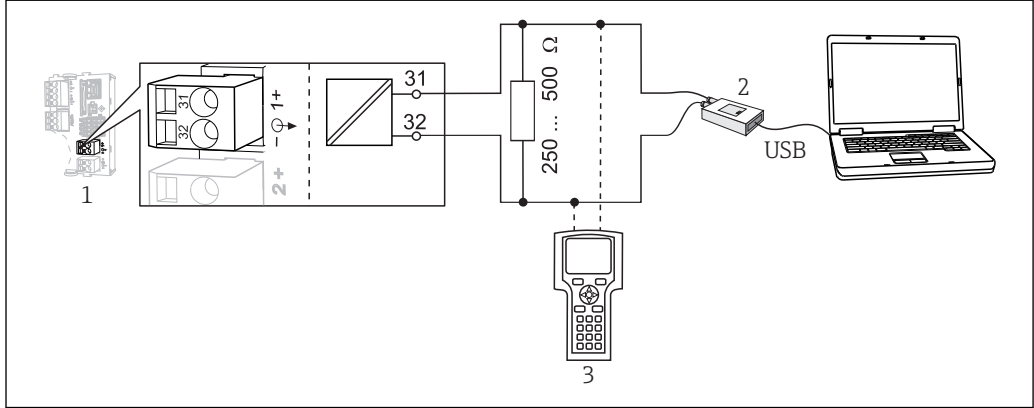

A0028995

42 HART using modem

- 1 Device module Base L, H or E: current output 1 with HART
 - 2 HART modem for connection to PC, e.g. Commubox FXA191 (RS232) or FXA195¹⁾ (USB)
 - 3 HART handheld terminal
- ¹⁾ Switch position "on" (substitutes the resistor)

Via PROFIBUS DP

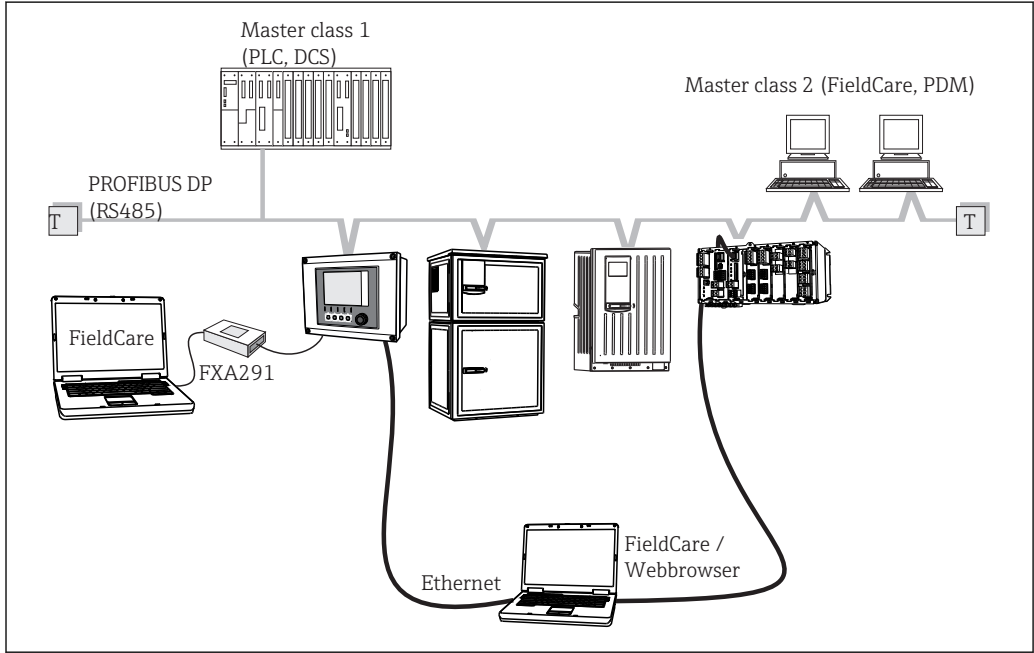

A0028991

43 PROFIBUS DP

T Terminating resistor

Via Modbus RS485

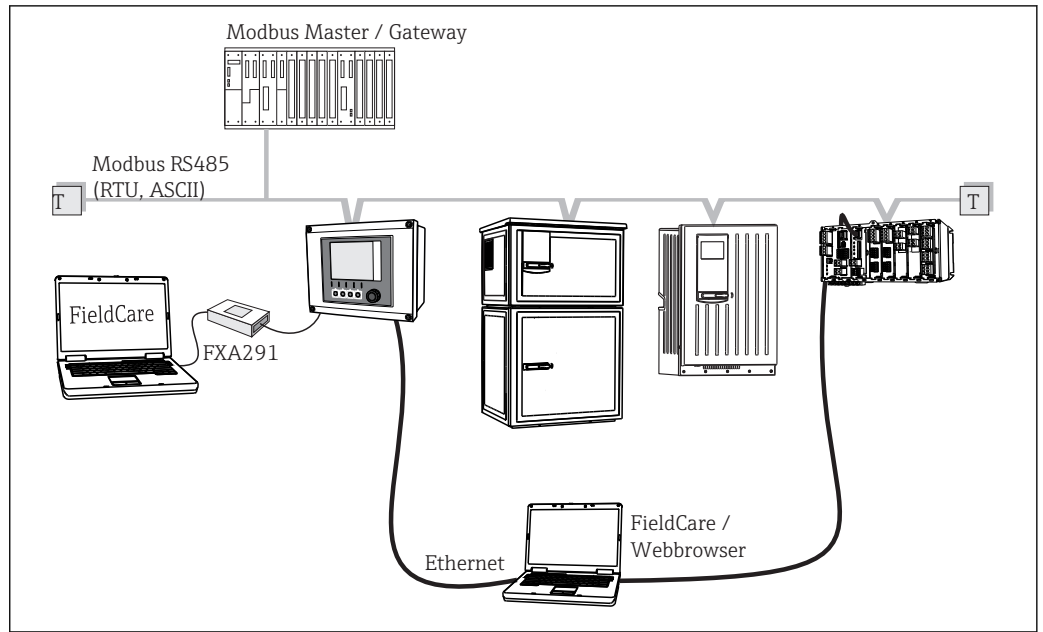

44 Modbus RS485

T Terminating resistor

Via Ethernet/Web server/Modbus TCP/EtherNet/IP

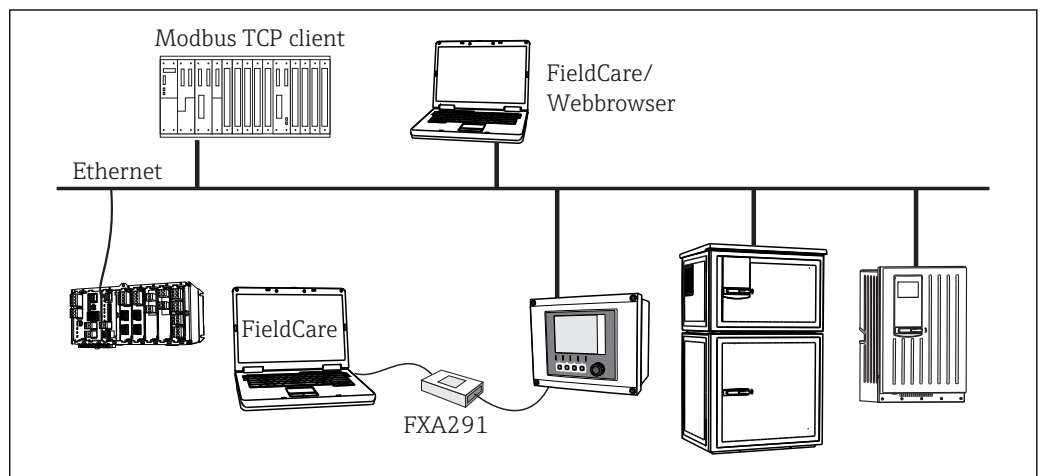

45 Modbus TCP and/or EtherNet/IP

Language packages

The language selected in the product structure is the operating language preset at the factory. All other languages can be selected using the menu.

- English (US)
- German
- Chinese (Simplified, PR China)
- Czech
- Dutch
- French
- Italian
- Japanese
- Polish
- Portuguese
- Russian

- Spanish
- Swedish
- Turkish
- Hungarian
- Croatian
- Vietnamese

The availability of other languages can be checked via the product structure at www.endress.com/cm442 or [.../cm444](http://www.endress.com/cm444) or [.../cm448](http://www.endress.com/cm448).

Certificates and approvals

SGC400 certificates and approvals

CE mark

The Modbus Edge Device SGC400 meets the legal requirements of the relevant EU Directives. The manufacturer has affixed the CE mark as confirmation that the Modbus Edge Device SGC400 has been successfully tested.

Radio approval

CE/ RED, EAC, FCC

Other standards and guidelines

Electrical safety IEC61010-1

In compliance with 2014/35/EU

CM444 certificates and approvals

The product meets the requirements of the harmonized European standards. As such, it complies with the legal specifications of the EU directives. The manufacturer confirms successful testing of the product by affixing to it the **CE** mark.

CE mark

The product meets the requirements of the harmonized European standards. As such, it complies with the legal specifications of the EU directives. The manufacturer confirms successful testing of the product by affixing to it the **CE** mark.

EAC

The product has been certified according to guidelines TP TC 004/2011 and TP TC 020/2011 which apply in the European Economic Area (EEA). The EAC conformity mark is affixed to the product.

cCSAus

The device has been certified with regard to its electrical safety and for NI Class I Div. 2 cCSAus explosion-proof environments. It meets the requirements in accordance with:

- CLASS 2252 06 - Process Control Equipment
- CLASS 2252 86 - Process Control Equipment - Certified to US Standards
- CLASS 2258 03 - Process Control Equipment - Intrinsically Safe and Non-incendive Systems - For Hazardous Locations
- CLASS 2258 83 - Process Control Equipment - Intrinsically Safe and Non-incendive Systems - For Hazardous Locations - Certified to US Standards
- FM3600
- FM3611
- FM3810
- ANSI/ISA NEMA250
- IEC 60529
- CAN/CSA-C22.2 No. 0
- CAN/CSA C22.2 No. 94
- CSA Std. C22.2 No. 213
- CAN/CSA-C22.2 No. 61010-1
- CAN/CSA-C22.2 No. 60529
- UL/ANSI/ISA 61010-1
- ANSI - ISA 12 12 01

CPF81D certificates and approvals	<p>Ex approval (optional) FM IS NI Cl. I Div.1&2, Groups A-D</p>
CLS50D certificates and approvals	<p>CE mark</p> <p><i>Declaration of Conformity</i></p> <p>The product meets the requirements of the harmonized European standards. As such, it complies with the legal specifications of the EC directives. The manufacturer confirms successful testing of the product by affixing to it the CE mark.</p> <p>Ex approvals</p> <p>CLS50D-BA and CLS50-G ATEX II 1G Ex ia IIC T4/T6 Ga</p> <p>CLS50D-BV ATEX II 3G Ex ic IIC T4/T6</p> <p>CLS50D-IA IECEX ia IIC T4/T6 Ga</p> <p>CLS50-V ATEX II 3G Ex ic IIC T4/T6 Gc + NEPSI Ex ic IIC T4/T6 Gc</p> <p>CLS50D-NA and CLS50-H NEPSI Ex ia IIC T4/T6 Ga</p> <p>CLS50D-FB and CLS50-O FM IS NI Cl.I Div.1&2,Group A-D</p> <p>CLS50D-C2 and CLS50-S CSA IS NI Cl.I, II, III Div.1&2,Group A-G</p> <p>CLS50-T TIIS Ex ia IIC T4</p>
COS51D certificates and approvals	<p>Ex approval</p> <p>Version COS51D-G**** ATEX II 1G/IECEX Ex ia IIC T6 Ga</p> <p>Version COS51D-O**** FM/CSA IS/NI CL I DIV 1&2 GP A-D</p>
CYA112 certificates and approvals	<p>Explosion protection</p> <p>The stainless steel version of the CYA112 assembly (CYA112-**21*2**) may also be used in the hazardous area in Zone 1 and 2.</p> <p>It does not have special Ex identification labeling, as the assembly does not have a potential ignition source of its own and ATEX Directive 94/9/EC therefore does not apply. Potential equalization must be implemented as described in the "Installation conditions" section.</p> <p>In the case of sensors with accessible metal surfaces, these surfaces must be included in the potential equalization system as indicated in the Operating Instructions for the sensor in question.</p>

Ordering information

For detailed information on the product structure, contact the Sales Center at www.addresses.endress.com or <http://www.endress.com/ssp100>

Scope of delivery	<p>The scope of delivery comprises:</p> <ul style="list-style-type: none"> ■ Modbus Edge Device SCG400 ■ LTE antenna ■ Cable grommet to connect the Ethernet cable for the Modbus TCP connection ■ 4-channel transmitter Liquiline CM444 - AN44AOF010BCB + AA ■ Digital pH sensor Orbipac CPF81D - 7NN11
--------------------------	---

- Digital conductivity sensor Indumax CLS50D - AA1B22
- Digital oxygen sensor Oxymax COS51D - AS800
- Digital measuring cable CYK10 - A102
- Immersion assembly Flexdip (thread G3/4) CYA112 - AB11A1BC
- Immersion assembly Flexdip (thread NPT3/4) CYA112 - AB11A1BB

Supplementary documentation

**Water Quality Smart System
Surface Water SSP100** Operating Instructions BA01929S/04/EN

**Water Quality Smart System
Aquaculture SSP200**

- Technical Information TI01421S/04/EN
- Operating Instructions BA01930S/04/EN

Modbus Edge Device SGC400 Technical Information TI01422S/04/EN

Liquiline CM444

- Technical Information TI00444C/07/EN
- Brief Operating Instructions KA01159C/07/EN
- Operating Instructions BA00444C/07/EN
- Installation Instructions EA00009C/07/A2

Orbipac CPF81D

- Technical Information TI00191C/07/EN
- Operating Instructions BA01572C/07/A2

Indumax CLS50D

- Technical Information TI00182C/07/EN
- Operating Instructions BA00182C/07/EN

Oxymax COS51D

- Technical Information TI00413C/07/EN
- Brief Operating Instructions KA00413C/07/EN
- Operating Instructions BA00413C/07/EN

Measuring cable CYK10

- Technical Information TI00118C/07/EN
- Operating Instructions BA00118C/07/A2

Flexdip CYA112

- Technical Information TI00432C/07/EN
- Operating Instructions BA00432C/07/EN

Registered trademarks

Modbus is the registered trademark of Modicon, Incorporated.

RUT240 is a product of Teltonika Ltd., 08105 Vilnius/Lithuania.

RevPi Core 3 is a product of Kunbus GmbH, 73770 Denkendorf/Germany.

UNO PS is a product of Phoenix CONTACT GmbH & Co. KG, 32825 Blomberg/Germany.

All other brand and product names are trademarks or registered trademarks of the companies and organizations in question.

www.addresses.endress.com
